



**THE DATASHEET OF  
74HC160N,652**



## Important notice

Dear Customer,

On 7 February 2017 the former NXP Standard Product business became a new company with the tradename **Nexperia**. Nexperia is an industry leading supplier of Discrete, Logic and PowerMOS semiconductors with its focus on the automotive, industrial, computing, consumer and wearable application markets

In data sheets and application notes which still contain NXP or Philips Semiconductors references, use the references to Nexperia, as shown below.

Instead of <http://www.nxp.com>, <http://www.philips.com/> or <http://www.semiconductors.philips.com/>, use <http://www.nexperia.com>

Instead of [sales.addresses@www.nxp.com](mailto:sales.addresses@www.nxp.com) or [sales.addresses@www.semiconductors.philips.com](mailto:sales.addresses@www.semiconductors.philips.com), use [salesaddresses@nexperia.com](mailto:salesaddresses@nexperia.com) (email)

Replace the copyright notice at the bottom of each page or elsewhere in the document, depending on the version, as shown below:

- © NXP N.V. (year). All rights reserved or © Koninklijke Philips Electronics N.V. (year). All rights reserved

Should be replaced with:

- © **Nexperia B.V. (year). All rights reserved.**

If you have any questions related to the data sheet, please contact our nearest sales office via e-mail or telephone (details via [salesaddresses@nexperia.com](mailto:salesaddresses@nexperia.com)). Thank you for your cooperation and understanding,

Kind regards,

Team Nexperia

# DATA SHEET

For a complete data sheet, please also download:

- The IC06 74HC/HCT/HCU/HCMOS Logic Family Specifications
- The IC06 74HC/HCT/HCU/HCMOS Logic Package Information
- The IC06 74HC/HCT/HCU/HCMOS Logic Package Outlines

## **74HC/HCT160**

Presettable synchronous BCD  
decade counter; asynchronous  
reset

Product specification  
File under Integrated Circuits, IC06

December 1990

# Presettable synchronous BCD decade counter; asynchronous reset

## 74HC/HCT160

### FEATURES

- Synchronous counting and loading
- Two count enable inputs for n-bit cascading
- Positive-edge triggered clock
- Asynchronous reset
- Output capability: standard
- I<sub>CC</sub> category: MSI

### GENERAL DESCRIPTION

The 74HC/HCT160 are high-speed Si-gate CMOS devices and are pin compatible with low power Schottky TTL (LSTTL). They are specified in compliance with JEDEC standard no. 7A.

The 74HC/HCT160 are synchronous presettable decade counters which feature an internal look-ahead carry and can be used for high-speed counting.

Synchronous operation is provided by having all flip-flops clocked simultaneously on the positive-going edge of the clock (CP).

The outputs (Q<sub>0</sub> to Q<sub>3</sub>) of the counters may be preset to a HIGH or LOW level. A LOW level at the parallel enable

input ( $\overline{PE}$ ) disables the counting action and causes the data at the data inputs (D<sub>0</sub> to D<sub>3</sub>) to be loaded into the counter on the positive-going edge of the clock (providing that the set-up and hold time requirements for  $\overline{PE}$  are met). Preset takes place regardless of the levels at count enable inputs (CEP and CET).

A LOW level at the master reset input ( $\overline{MR}$ ) sets all four outputs of the flip-flops (Q<sub>0</sub> to Q<sub>3</sub>) to LOW level regardless of the levels at CP,  $\overline{PE}$ , CET and CEP inputs (thus providing an asynchronous clear function).

The look-ahead carry simplifies serial cascading of the counters. Both count enable inputs (CEP and CET) must be HIGH to count. The CET input is fed forward to enable the terminal count output (TC). The TC output thus enabled will produce a HIGH output pulse of a duration approximately equal to a HIGH level output of Q<sub>0</sub>. This pulse can be used to enable the next cascaded stage.

The maximum clock frequency for the cascaded counters is determined by the CP to TC propagation delay and CEP to CP set-up time, according to the following formula:

$$f_{\max} = \frac{1}{t_{P(\max)} (\text{CP to TC}) + t_{\text{SU}} (\text{CEP to CP})}$$

### QUICK REFERENCE DATA

GND = 0 V; T<sub>amb</sub> = 25 °C; t<sub>r</sub> = t<sub>f</sub> = 6 ns

SYMBOL	PARAMETER	CONDITIONS	TYPICAL		UNIT
			HC	HCT	
t <sub>PHL</sub>	propagation delay CP to Q <sub>n</sub> CP to TC $\overline{MR}$ to Q <sub>n</sub> $\overline{MR}$ to TC CET to TC	C <sub>L</sub> = 15 pF; V <sub>CC</sub> = 5 V	19	21	ns
			21	24	ns
			21	23	ns
			21	26	ns
			14	14	ns
t <sub>PLH</sub>	propagation delay CP to Q <sub>n</sub> CP to TC CET to TC		19	21	ns
			21	20	ns
			14	7	ns
			61	31	MHz
f <sub>max</sub>	maximum clock frequency				
C <sub>I</sub>	input capacitance		3.5	3.5	pF
C <sub>PD</sub>	power dissipation capacitance per package	notes 1 and 2	39	34	pF

### Notes

1. C<sub>PD</sub> is used to determine the dynamic power dissipation (P<sub>D</sub> in μW):

$$P_D = C_{PD} \times V_{CC}^2 \times f_i + \sum (C_L \times V_{CC}^2 \times f_o)$$

where:

- f<sub>i</sub> = input frequency in MHz
  - f<sub>o</sub> = output frequency in MHz
  - ∑ (C<sub>L</sub> × V<sub>CC</sub><sup>2</sup> × f<sub>o</sub>) = sum of outputs
  - C<sub>L</sub> = output load capacitance in pF
  - V<sub>CC</sub> = supply voltage in V
2. For HC the condition is  
V<sub>I</sub> = GND to V<sub>CC</sub>  
For HCT the condition is  
V<sub>I</sub> = GND to V<sub>CC</sub> – 1.5 V

Pre-settable synchronous BCD decade counter; asynchronous reset

74HC/HCT160

ORDERING INFORMATION

See "74HC/HCT/HCU/HCMOS Logic Package Information".

PIN DESCRIPTION

PIN NO.	SYMBOL	NAME AND FUNCTION
1	$\overline{MR}$	asynchronous master reset (active LOW)
2	CP	clock input (LOW-to-HIGH, edge-triggered)
3, 4, 5, 6	D <sub>0</sub> to D <sub>3</sub>	data inputs
7	CEP	count enable input
8	GND	ground (0 V)
9	$\overline{PE}$	parallel enable input (active LOW)
10	CET	count enable carry input
14, 13, 12, 11	Q <sub>0</sub> to Q <sub>3</sub>	flip-flop outputs
15	TC	terminal count output
16	V <sub>CC</sub>	positive supply voltage

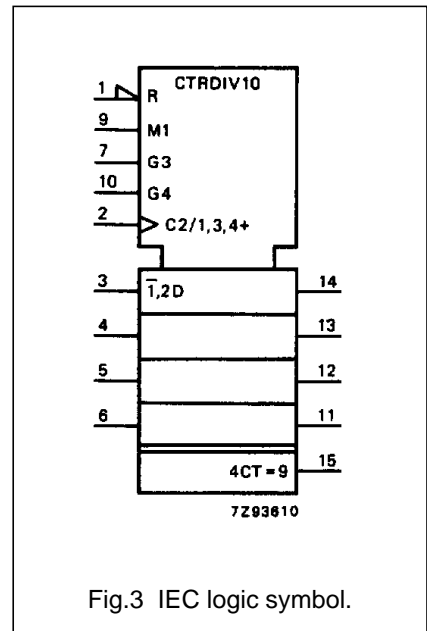
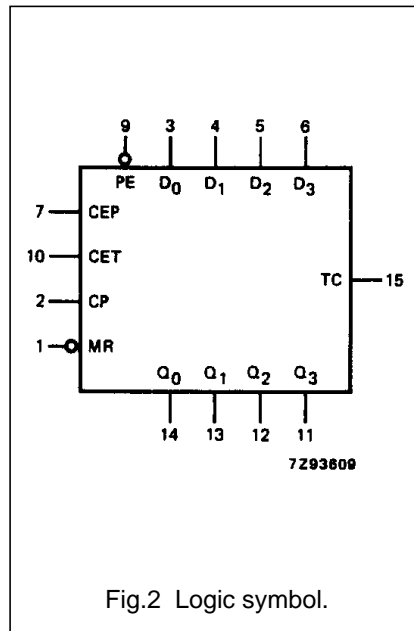
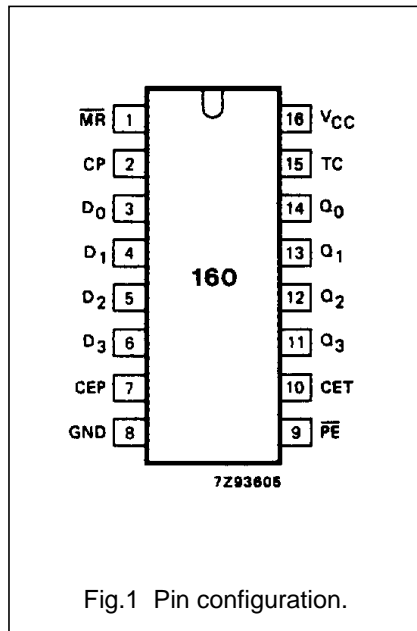

Pre-settable synchronous BCD decade counter; asynchronous reset

74HC/HCT160

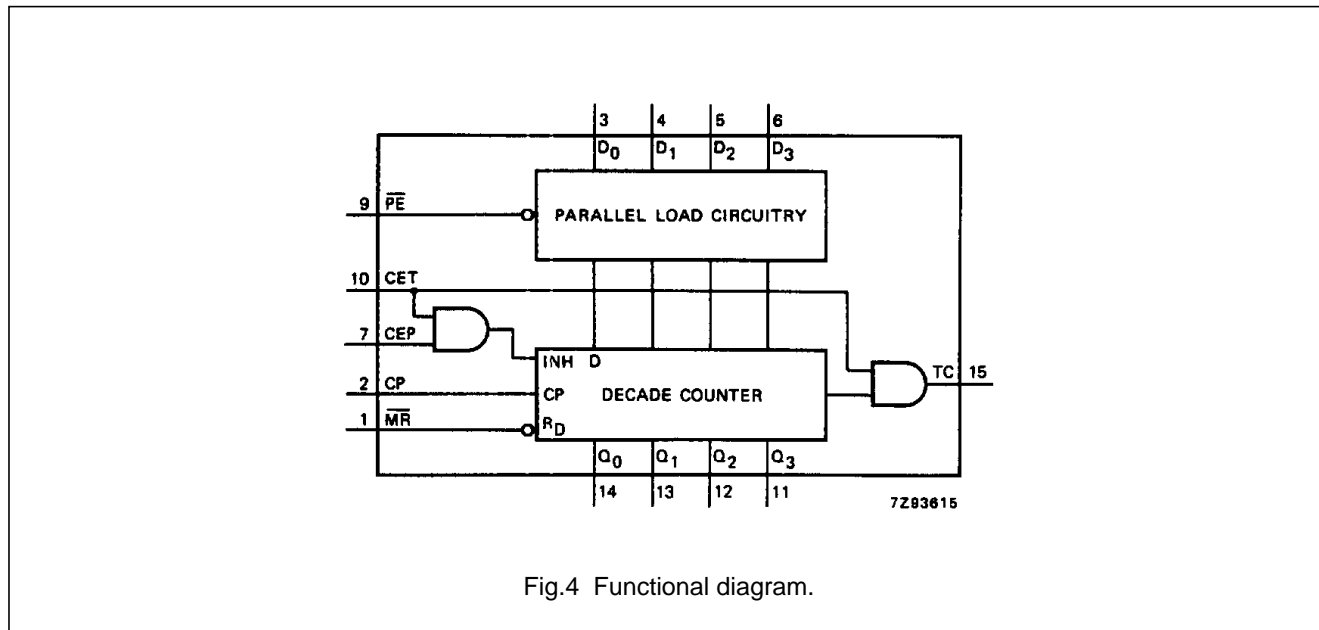

Fig.4 Functional diagram.

FUNCTION TABLE

OPERATING MODE	INPUTS						OUTPUTS	
	$\overline{MR}$	CP	CEP	CET	$\overline{PE}$	$D_n$	$Q_n$	TC
reset (clear)	L	X	X	X	X	X	L	L
parallel load	H	↑	X	X	l	l	L	L
	H	↑	X	X	l	h	H	(1)
count	H	↑	h	h	h	X	count	(1)
hold (do nothing)	H	X	l	X	h	X	$q_n$	(1)
	H	X	X	l	h	X	$q_n$	L

Notes

- The TC output is HIGH when CET is HIGH and the counter is at terminal count (HLLH).  
 H = HIGH voltage level  
 h = HIGH voltage level one set-up time prior to the LOW-to-HIGH CP transition  
 L = LOW voltage level  
 l = LOW voltage level one set-up time prior to the LOW-to-HIGH CP transition  
 q = lower case letters indicate the state of the referenced output one set-up time prior to the LOW-to-HIGH CP transition  
 X = don't care  
 ↑ = LOW-to-HIGH CP transition

Pre-settable synchronous BCD decade counter; asynchronous reset

74HC/HCT160

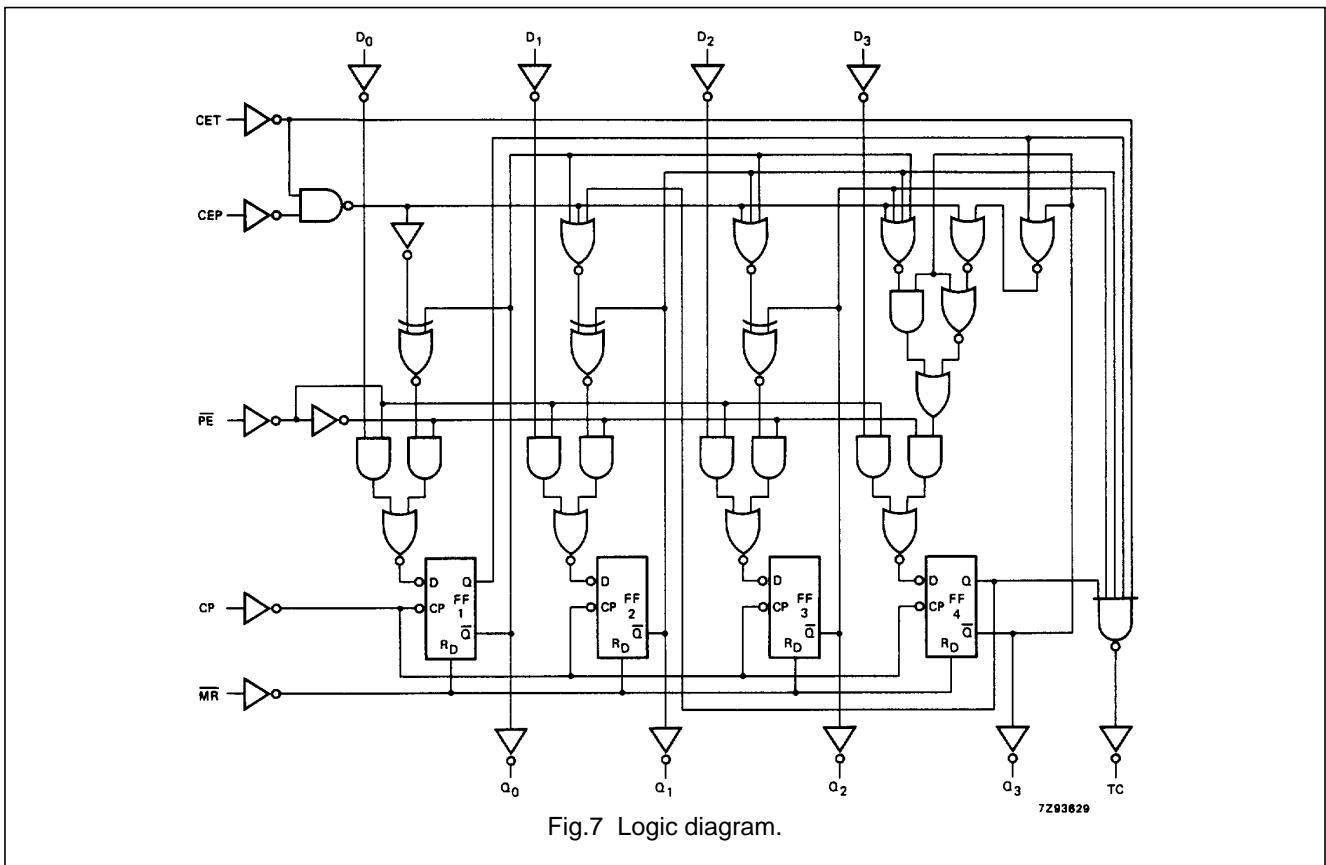
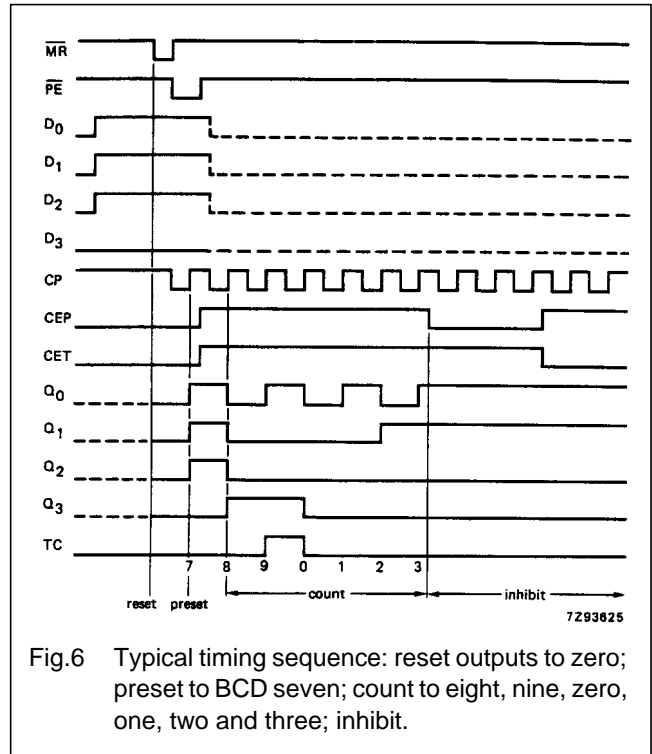
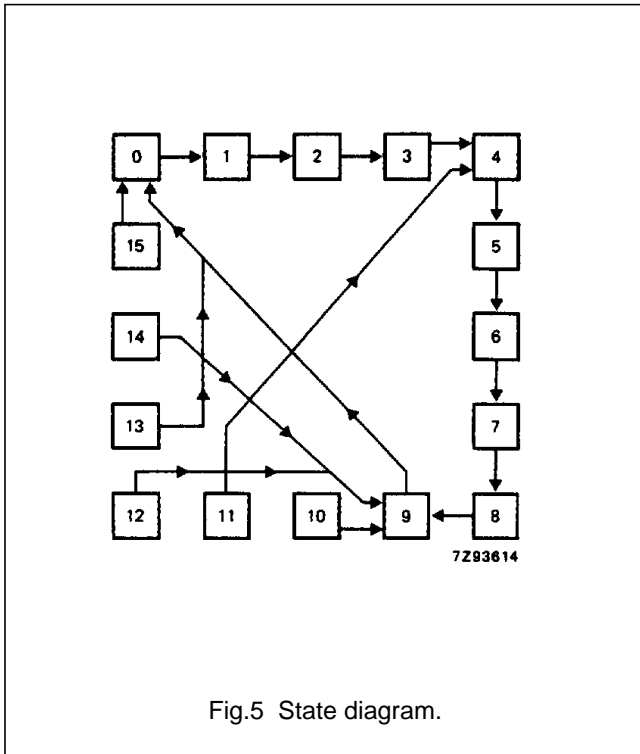

# Presettable synchronous BCD decade counter; asynchronous reset

74HC/HCT160

## DC CHARACTERISTICS FOR 74HC

For the DC characteristics see *"74HC/HCT/HCU/HCMOS Logic Family Specifications"*.

Output capability: standard

I<sub>CC</sub> category: MSI

## AC CHARACTERISTICS FOR 74HC

GND = 0 V; t<sub>r</sub> = t<sub>f</sub> = 6 ns; C<sub>L</sub> = 50 pF

SYMBOL	PARAMETER	T <sub>amb</sub> (°C)						UNIT	TEST CONDITIONS		
		74HC							V <sub>CC</sub> (V)	WAVEFORMS	
		+25			-40 to +85		-40 to +125				
		min.	typ.	max.	min.	max.	min.				max.
t <sub>PHL</sub> / t <sub>PLH</sub>	propagation delay CP to Q <sub>n</sub>		61 22 18	185 37 31		230 46 39		280 56 48	ns	2.0 4.5 6.0	Fig. 8
t <sub>PHL</sub> / t <sub>PLH</sub>	propagation delay CP to TC		69 25 20	215 43 31		270 54 46		325 65 55	ns	2.0 4.5 6.0	Fig. 8
t <sub>PHL</sub>	propagation delay MR to Q <sub>n</sub>		69 25 20	210 42 36		265 53 45		315 63 54	ns	2.0 4.5 6.0	Fig. 9
t <sub>PHL</sub>	propagation delay MR to TC		69 25 20	220 44 37		275 55 47		330 66 56	ns	2.0 4.5 6.0	Fig. 9
t <sub>PHL</sub> / t <sub>PLH</sub>	propagation delay CET to TC		47 17 14	150 30 26		190 38 33		225 45 38	ns	2.0 4.5 6.0	Fig. 10
t <sub>THL</sub> / t <sub>TLH</sub>	output transition time		19 7 6	75 15 13		95 19 16		110 22 19	ns	2.0 4.5 6.0	Figs 8 and 10
t <sub>w</sub>	clock pulse width HIGH or LOW	80 16 14	22 8 6		100 20 17		120 24 20		ns	2.0 4.5 6.0	Fig. 8
t <sub>w</sub>	master reset pulse width LOW	80 16 14	28 10 8		100 20 17		120 24 20		ns	2.0 4.5 6.0	Fig. 9
t <sub>rem</sub>	removal time MR to CP	100 20 17	30 11 9		125 25 21		150 30 26		ns	2.0 4.5 6.0	Fig. 9
t <sub>su</sub>	set-up time D <sub>n</sub> to CP	80 16 14	22 8 6		100 20 17		120 24 20		ns	2.0 4.5 6.0	Fig. 11
t <sub>su</sub>	set-up time PE to CP	135 27 23	41 15 12		170 34 29		205 41 35		ns	2.0 4.5 6.0	Fig. 11

Presettable synchronous BCD decade  
counter; asynchronous reset

74HC/HCT160

SYMBOL	PARAMETER	T <sub>amb</sub> (°C)							UNIT	TEST CONDITIONS	
		74HC								V <sub>CC</sub> (V)	WAVEFORMS
		+25			-40 to +85		-40 to +125				
		min.	typ.	max.	min.	max.	min.	max.			
t <sub>su</sub>	set-up time CEP, CET to CP	200 40 34	63 23 18		250 50 43		300 60 51		ns	2.0 4.5 6.0	Fig. 12
t <sub>h</sub>	hold time D <sub>n</sub> to CP	0 0 0	-17 -6 -5		0 0 0		0 0 0		ns	2.0 4.5 6.0	Figs 11 and 12
t <sub>h</sub>	hold time $\overline{\text{PE}}$ to CP	0 0 0	-41 -15 -12		0 0 0		0 0 0		ns	2.0 4.5 6.0	Figs 11 and 12
t <sub>h</sub>	hold time CEP, CET to CP	0 0 0	-58 -21 -17		0 0 0		0 0 0		ns	2.0 4.5 6.0	Figs 11 and 12
f <sub>max</sub>	maximum clock pulse frequency	6.0 30 35	18 55 66		4.8 24 28		4.0 20 24		MHz	2.0 4.5 6.0	Fig. 8

---

Presettable synchronous BCD decade  
counter; asynchronous reset

---

74HC/HCT160

**DC CHARACTERISTICS FOR 74HCT**

For the DC characteristics see *"74HC/HCT/HCU/HCMOS Logic Family Specifications"*.

Output capability: standard

I<sub>CC</sub> category: MSI

**Note to HCT types**

The value of additional quiescent supply current ( $\Delta I_{CC}$ ) for unit load of 1 is given in the family specifications. To determine  $\Delta I_{CC}$  per input, multiply this value by the unit load coefficient shown in the table below.

INPUT	UNIT LOAD COEFFICIENT
$\overline{MR}$	0.95
CP	0.80
CEP	0.25
$D_n$	0.25
CET	1.05
$\overline{PT}$	0.30

# Presettable synchronous BCD decade counter; asynchronous reset

74HC/HCT160

## AC CHARACTERISTICS FOR 74HCT

GND = 0 V;  $t_r = t_f = 6$  ns;  $C_L = 50$  pF



SYMBOL	PARAMETER	$T_{amb}$ (°C)						UNIT	TEST CONDITIONS		
		74HCT							$V_{CC}$ (V)	WAVEFORMS	
		+25			-40 to +85		-40 to +125				
		min.	typ.	max.	min.	max.	min.				max.
$t_{PHL}/t_{PLH}$	propagation delay CP to $Q_n$		25	43		54		65	ns	4.5	Fig. 8
$t_{PHL}$	propagation delay CP to TC		28	48		60		72	ns	4.5	Fig. 8
$t_{PLH}$	propagation delay CP to TC		23	39		49		59	ns	4.5	Fig. 8
$t_{PHL}$	propagation delay MR to $Q_n$		27	50		63		75	ns	4.5	Fig. 9
$t_{PHL}$	propagation delay $\overline{MR}$ to TC		30	50		63		75	ns	4.5	Fig. 9
$t_{PHL}$	propagation delay CET to TC		17	35		44		53	ns	4.5	Fig. 10
$t_{PLH}$	propagation delay CET to TC		9	17		21		26	ns	4.5	Fig. 10
$t_{THL}/t_{TLH}$	output transition time		7	15		19		22	ns	4.5	Figs 8 and 10
$t_W$	clock pulse width HIGH or LOW	16	8		20		24		ns	4.5	Fig. 8
$t_W$	master reset pulse width LOW	20	11		25		30		ns	4.5	Fig. 9
$t_{rem}$	removal time MR to CP	20	9		25		30		ns	4.5	Fig. 9
$t_{su}$	set-up time $D_n$ to CP	18	10		25		30		ns	4.5	Fig. 11
$t_{su}$	set-up time $\overline{PE}$ to CP	30	18		44		53		ns	4.5	Fig. 11
$t_{su}$	set-up time CEP, CET to CP	50	30		63		75		ns	4.5	Fig. 12
$t_h$	hold time $D_n$ to CP	0	-8		0		0		ns	4.5	Figs 11 and 12
$t_h$	hold time $\overline{PE}$ to CP	0	-13		0		0		ns	4.5	Figs 11 and 12
$t_h$	hold time CEP, CET to CP	0	-21		0		0		ns	4.5	Figs 11 and 12
$f_{max}$	maximum clock pulse frequency	16	28		13		11		MHz	4.5	Fig. 8

## PACKAGE OUTLINES

See "74HC/HCT/HCU/HCMOS Logic Package Outlines".

## Looking for pricing, stock, or lifecycle information?

Click below to explore more details on WIN SOURCE:

-  [View 74HC160N,652 on WIN SOURCE](#)
-  [NXP / Nexperia Information](#)

## Optimize Your Supply Chain with WIN SOURCE Solutions

-  Global Sourcing Solution
-  Obsolete Management
-  Cost Control Management
-  Shortage Management
-  Alternative Solution
-  Excess Inventory Management