

DATA SHEET

74F191

Up/down binary counter with reset and ripple clock

Product specification

1995 Jul 17

IC15 Data Handbook

Up/Down binary counter with reset and ripple clock

74F191

FEATURES

- High speed –125MHz typical f_{MAX}
- Synchronous, reversible counting
- 4-Bit binary
- Asynchronous parallel load capability
- Cascadable without external logic
- Single up/down control input

DESCRIPTION

The 74F191 is a 4-bit binary counter. It contains four edge-triggered master/slave flip-flops with internal gating and steering logic to provide asynchronous preset and synchronous count-up and count-down operations.

Asynchronous parallel load capability permits the counter to be preset to any desired number. Information present on the parallel data inputs ($D_0 - D_3$) is loaded into the counter and appears on the outputs when the Parallel Load (\overline{PL}) input is Low. This operation overrides the counting function. Counting is inhibited by a High level on the count enable (\overline{CE}) input. When \overline{CE} is Low, internal state changes are initiated. Overflow/underflow indications are provided by two types of outputs, the Terminal Count (TC) and Ripple Clock (\overline{RC}).

The TC output is normally Low and goes High when: 1) the count reaches zero in the countdown mode or 2) reaches “15” in the count up mode. The TC output will remain High until a state change occurs, either by counting or presetting, or until $\overline{U/D}$ is changed. TC output should not be used as a clock signal because it is subject to decoding spikes. The TC signal is used internally to enable the \overline{RC} output. When TC is High and \overline{CE} is Low, the \overline{RC} follows the clock pulse. The \overline{RC} output essentially duplicates the Low clock pulse width, although delayed in time by two gate delays.

PIN CONFIGURATION

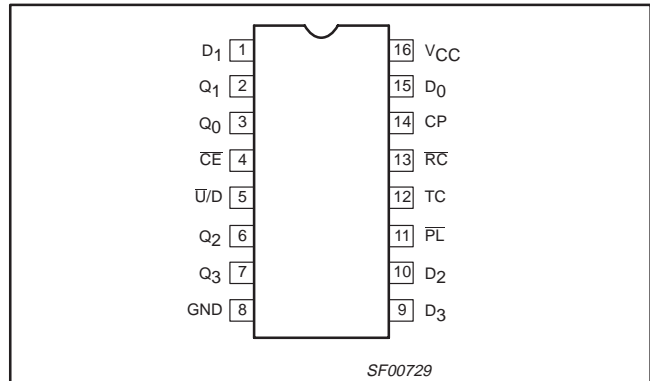

TYPE	TYPICAL f_{MAX}	TYPICAL SUPPLY CURRENT (TOTAL)
74F191	125MHz	40mA

ORDERING INFORMATION

DESCRIPTION	COMMERCIAL RANGE $V_{CC} = 5V \pm 10\%$, $T_{amb} = 0^\circ C \text{ to } +70^\circ C$	PKG DWG #
16-pin plastic DIP	N74F191N	SOT38-4
16-pin plastic SO	N74F191D	SOT109-1

INPUT AND OUTPUT LOADING AND FAN-OUT TABLE

PINS	DESCRIPTION	74F(U.L.) HIGH/LOW	LOAD VALUE HIGH/LOW
$D_0 - D_3$	Data inputs	1.0/1.0	20 μ A/0.6mA
\overline{CE}	Count enable input (active Low)	1.0/3.0	20 μ A/1.8mA
CP	Clock pulse input (active rising edge)	1.0/1.0	20 μ A/0.6mA
\overline{PL}	Asynchronous parallel load control input (active Low)	1.0/1.0	20 μ A/0.6mA
$\overline{U/D}$	Up/down count control input	1.0/1.0	20 μ A/0.6mA
$Q_0 - Q_3$	Flip-flop outputs	50/33	1.0mA/20mA
\overline{RC}	Ripple clock output (active low)	50/33	1.0mA/20mA
TC	Terminal count output	50/33	1.0mA/20mA

NOTE: One (1.0) FAST Unit Load (U.L.) is defined as: 20 μ A in the High state and 0.6mA in the Low state.

Up/Down binary counter with reset and ripple clock

74F191

LOGIC SYMBOL

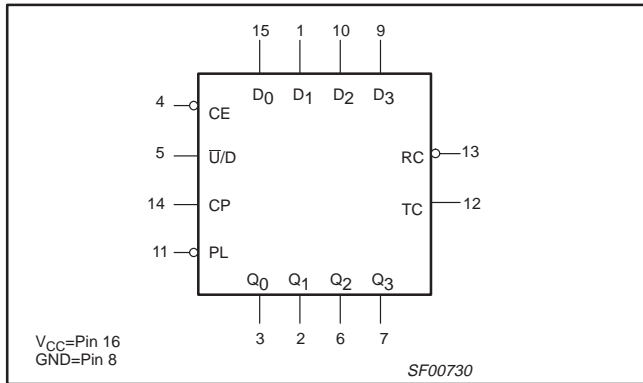

LOGIC SYMBOL (IEEE/IEC)

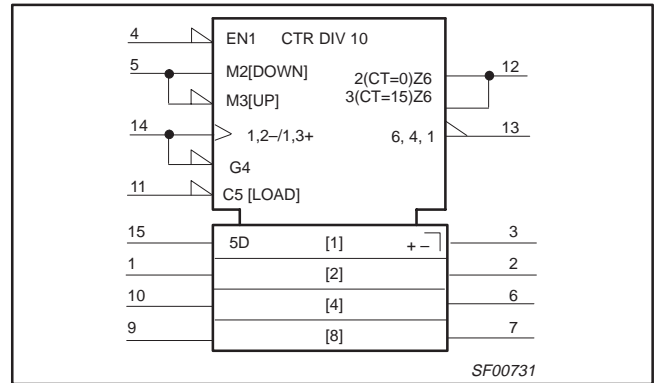

LOGIC DIAGRAM

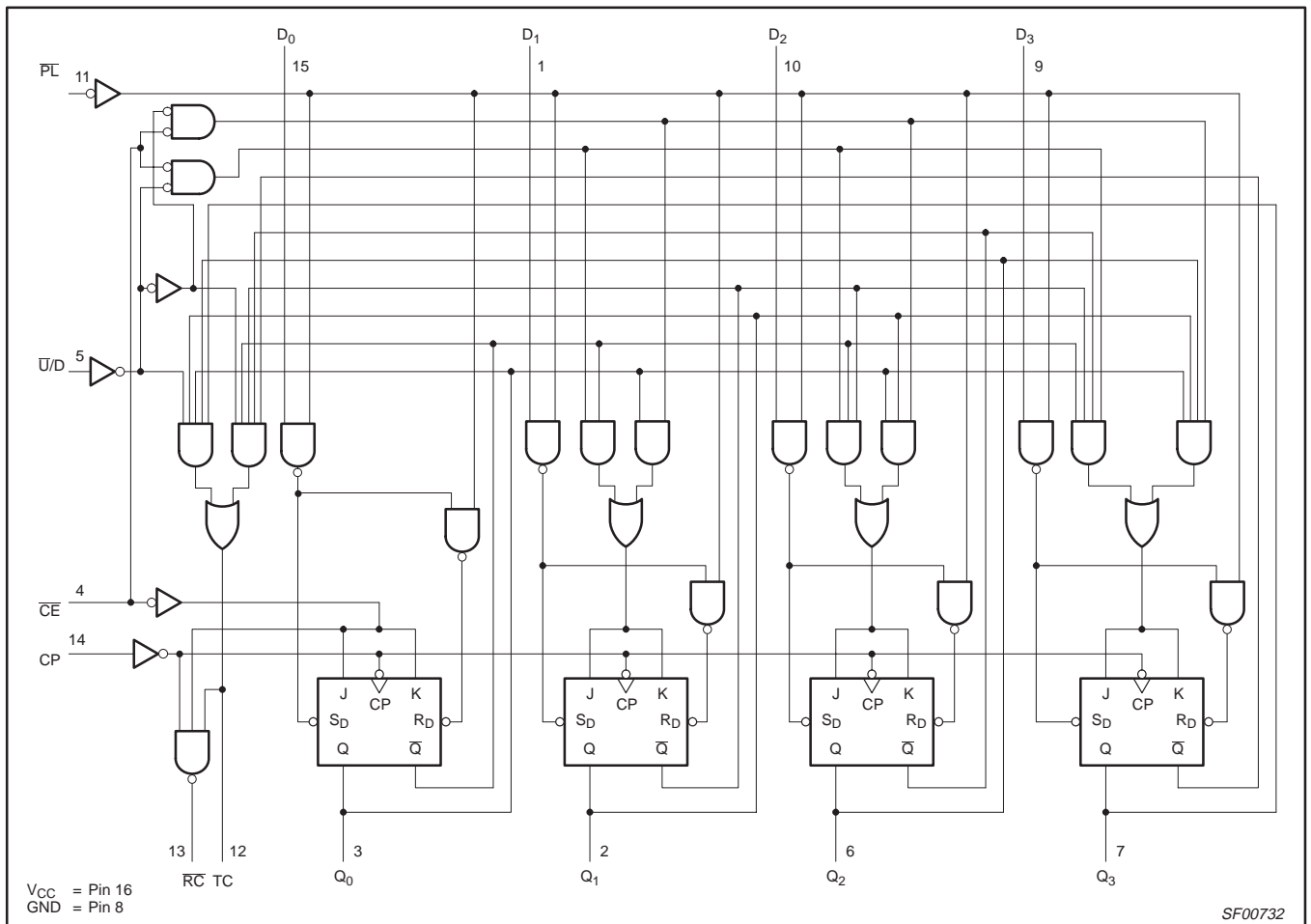

Up/Down binary counter with reset and ripple clock

74F191

MODE SELECT — FUNCTION TABLE

INPUTS					OUTPUTS	OPERATING MODE
\overline{PL}	$\overline{U/D}$	\overline{CE}	CP	D_n	Q_n	
L	X	X	X	L	L	Parallel load
L	X	X	X	H	H	
H	L	l	↑	X	Count up	Count up
H	H	l	↑	X	Count down	Count down
H	X	H	X	X	No change	Hold (do nothing)

TC AND \overline{RC} FUNCTION TABLE

INPUTS			TERMINAL COUNT STATE				OUTPUTS	
$\overline{U/D}$	\overline{CE}	CP	Q_0	Q_1	Q_2	Q_3	TC	\overline{RC}
H	H	X	H	H	H	H	L	H
L	H	X	H	H	H	H	H	H
L	L	⌊	H	H	H	H	H	⌊
L	H	X	L	L	L	L	L	H
H	H	X	L	L	L	L	H	H
H	L	⌊	L	L	L	L	H	⌊

- H = High voltage level steady state
- L = Low voltage level steady state
- X = Don't care
- ⌊ = Low pulse
- ↑ = Low-to-High clock transition
- l = Low voltage level one set-up time prior to the Low-to-High clock transition

Up/Down binary counter with reset and ripple clock

74F191

APPLICATIONS

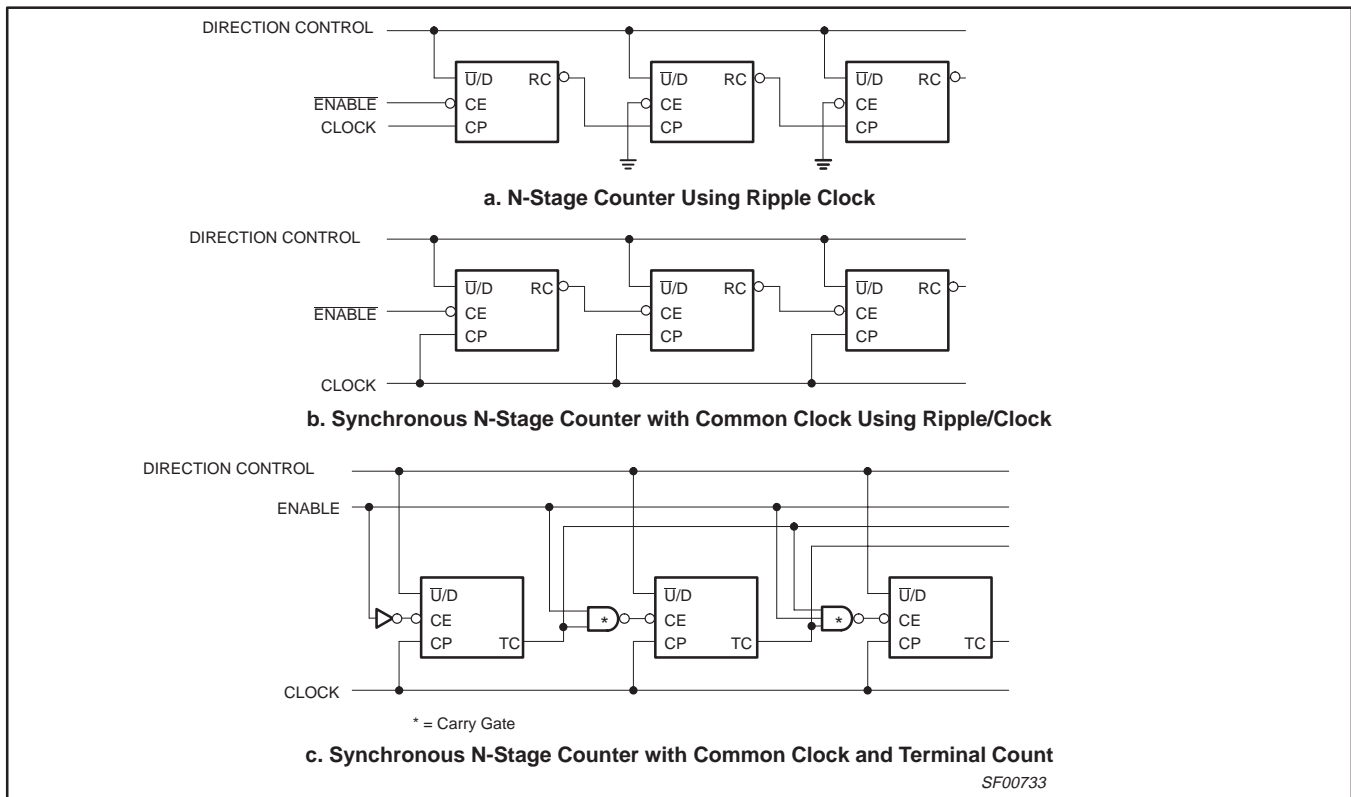

Figure 1.

The 74F191 simplifies the design of multi-stage counters, as indicated in Figure 1, each \overline{RC} output is used as the clock input for the next higher stage. When the clock source has a limited drive capability this configuration is particularly advantageous, since the clock source drives only the first stage. It is only necessary to inhibit the first stage to prevent counting in all stages, since a High signal on \overline{CE} inhibits the \overline{RC} output pulse as indicated in the Mode Select Table. The timing skew between state changes in the first and last stages is represented by the cumulative delay of the clock as it ripples through the preceding stages. This is a disadvantage of the configuration in some applications.

Figure 1b shows a method of causing state changes to occur simultaneously in all stages. The \overline{RC} output signals propagate in

ripple fashion and all clock inputs are driven in parallel. The Low state duration of the clock in this configuration must be long enough to allow the negative-going edge of the \overline{RC} signal to ripple through to the last stage before the clock goes High. Since the \overline{RC} output of any package goes High shortly after its clock input goes High, there is no such restriction on the High state duration of the clock.

In Figure 1c, the configuration shown avoids ripple delays and their associated restrictions. The combined TC signals from all the preceding stages forms the \overline{CE} input signal for a given stage. An enable signal must also be included in each carry gate in order to inhibit counting. The TC output of a given stage is not affected by its own \overline{CE} , therefore, the simple inhibit scheme of Figure 1a and 1b does not apply.

Up/Down binary counter with reset and ripple clock

74F191

ABSOLUTE MAXIMUM RATINGS

(Operation beyond the limits set forth in this table may impair the useful life of the device.
Unless otherwise noted these limits are over the operating free-air temperature range.)

SYMBOL	PARAMETER	RATING	UNIT
V _{CC}	Supply voltage	-0.5 to +7.0	V
V _{IN}	Input voltage	-0.5 to +7.0	V
I _{IN}	Input current	-30 to +5.0	mA
V _{OUT}	Voltage applied to output in High output state	-0.5 to +V _{CC}	V
I _{OUT}	Current applied to output in Low output state	40	mA
T _{amb}	Operating free-air temperature range	0 to +70	°C
T _{stg}	Storage temperature	-65 to +150	°C

RECOMMENDED OPERATING CONDITIONS

SYMBOL	PARAMETER	LIMITS			UNIT
		Min	Nom	Max	
V _{CC}	Supply voltage	4.5	5.0	5.5	V
V _{IH}	High-level input voltage	2.0			V
V _{IL}	Low-level input voltage			0.8	V
I _{IK}	Input clamp current			-18	mA
I _{OH}	High-level output current			-1	mA
I _{OL}	Low-level output current			20	mA
T _{amb}	Operating free-air temperature range	0		70	°C

DC ELECTRICAL CHARACTERISTICS

(Over recommended operating free-air temperature range unless otherwise noted.)

SYMBOL	PARAMETER	TEST CONDITIONS ¹	LIMITS			UNIT	
			Min	Typ ²	Max		
V _{OH}	High-level output voltage	V _{CC} = Min, V _{IL} = Max, I _{OH} = Max, V _{IH} = Min	±10%V _{CC}	2.5		V	
			±5%V _{CC}	2.7	3.4	V	
V _{OL}	Low-level output voltage	V _{CC} = Min, V _{IL} = Max, I _{OL} = Max, V _{IH} = Min	±10%V _{CC}		0.30	0.50	V
			±5%V _{CC}		0.30	0.50	V
V _{IK}	Input clamp voltage	V _{CC} = Min, I _I = I _{IK}		-0.73	-1.2	V	
I _I	Input current at maximum input voltage	V _{CC} = Max, V _I = 7.0V			100	μA	
I _{IH}	High-level input current	V _{CC} = Max, V _I = 2.7V			20	μA	
I _{IL}	Low-level input current	V _{CC} = Max, V _I = 0.5V	CE		-1.8	mA	
			Others		-0.6	mA	
I _{OS}	Short-circuit output current ³	V _{CC} = Max	-60		-150	mA	
I _{CC}	Supply current ⁴ (total)	V _{CC} = Max		40	55	mA	

NOTES:

- For conditions shown as MIN or MAX, use the appropriate value specified under recommended operating conditions for the applicable type.
- All typical values are at V_{CC} = 5V, T_{amb} = 25°C.
- Not more than one output should be shorted at a time. For testing I_{OS}, the use of high-speed test apparatus and/or sample-and-hold techniques are preferable in order to minimize internal heating and more accurately reflect operational values. Otherwise, prolonged shorting of a High output may raise the chip temperature well above normal and thereby cause invalid readings in other parameter tests. In any sequence of parameter tests, I_{OS} tests should be performed last.
- Measure I_{CC} all inputs grounded and all outputs open.

Up/Down binary counter with reset and ripple clock

74F191

AC ELECTRICAL CHARACTERISTICS

SYMBOL	PARAMETER	TEST CONDITIONS	LIMITS					UNIT
			T _{amb} = +25°C V _{CC} = +5.0V C _L = 50pF, R _L = 500Ω			T _{amb} = 0°C to +70°C V _{CC} = +5.0V ± 10% C _L = 50pF, R _L = 500Ω		
			Min	Typ	Max	Min	Max	
f _{MAX}	Maximum clock frequency to Q _n outputs	Waveform 1	100	125		90		MHz
f _{MAX}	Maximum clock frequency to RC outputs	Waveform 1	85	95		75		MHz
t _{PLH} t _{PHL}	Propagation delay CP to Q _n	Waveform 1	2.5 5.0	4.5 7.5	8.0 11.5	2.0 5.0	8.5 12.0	ns ns
t _{PLH} t _{PHL}	Propagation delay CP to TC	Waveform 1	6.5 6.0	9.0 8.0	12.5 11.0	6.0 6.0	13.0 12.0	ns ns
t _{PLH} t _{PHL}	Propagation delay CP to RC	Waveform 2	2.5 3.0	4.5 5.0	7.5 7.5	2.0 2.5	8.0 8.0	ns ns
t _{PLH} t _{PHL}	Propagation delay CE to RC	Waveform 2	2.0 3.0	4.0 5.0	7.0 7.5	2.0 3.0	7.5 8.0	ns ns
t _{PLH} t _{PHL}	Propagation delay U/D to RC	Waveform 2	8.0 4.5	11.0 7.5	16.0 10.5	8.0 4.0	17.0 11.0	ns ns
t _{PLH} t _{PHL}	Propagation delay U/D to TC	Waveform 4	4.0 3.0	6.5 6.0	9.5 9.5	3.0 3.0	10.5 10.0	ns ns
t _{PLH} t _{PHL}	Propagation delay D _n to Q _n	Waveform 3	2.0 6.5	4.0 9.0	7.0 12.0	1.5 6.5	7.5 13.0	ns ns
t _{PLH} t _{PHL}	Propagation delay D _n to TC	Waveform 3 Waveform 4	5.5 6.5	9.5 9.5	13.0 13.0	5.0 6.0	14.0 14.0	ns ns
t _{PLH} t _{PHL}	Propagation delay D _n to RC	Waveform 3 Waveform 4	6.0 6.0	14.0 11.0	18.0 13.5	6.0 6.0	19.5 15.0	ns ns
t _{PLH} t _{PHL}	Propagation delay PL to Q _n	Waveform 5	4.5 5.5	6.5 8.0	9.5 11.5	4.0 5.0	10.5 12.0	ns ns
t _{PLH} t _{PHL}	Propagation delay PL to TC	Waveform 5	5.5 6.0	8.5 10.5	12.0 13.5	5.5 6.0	13.0 14.5	ns ns
t _{PLH} t _{PHL}	Propagation delay PL to RC	Waveform 5	8.5 7.5	16.0 10.0	18.5 13.0	8.5 7.0	21.0 13.5	ns ns

Up/Down binary counter with reset and ripple clock

74F191

AC SETUP REQUIREMENTS

SYMBOL	PARAMETER	TEST CONDITIONS	LIMITS					UNIT
			T _{amb} = +25°C V _{CC} = +5.0V C _L = 50pF, R _L = 500Ω			T _{amb} = 0°C to +70°C V _{CC} = +5.0V ± 10% C _L = 50pF, R _L = 500Ω		
			Min	Typ	Max	Min	Max	
t _s (H) t _s (L)	Setup time, High or Low D _n to \overline{PL}	Waveform 6	4.5 4.5			5.0 5.0		ns ns
t _h (H) t _h (L)	Hold time, High or Low D _n to \overline{PL}	Waveform 6	2.0 2.0			2.0 2.0		ns ns
t _s (L)	Setup time, Low \overline{CE} to CP	Waveform 6	10.0			10.0		ns
t _h (L)	Hold time, Low \overline{CE} to CP	Waveform 6	0			0		ns
t _s (H) t _s (L)	Setup time, High or Low U/D to CP	Waveform 6	12.0 12.0			12.0 12.0		ns ns
t _h (H) t _h (L)	Hold time, High or Low U/D to CP	Waveform 6	0 0			0 0		ns ns
t _w (H) t _w (L)	CP Pulse width, High or Low	Waveform 1	3.5 6.0			3.5 6.0		ns ns
t _w (L)	PL Pulse width, Low	Waveform 5	6.0			6.0		ns
t _{rec}	Recovery time, \overline{PL} to CP	Waveform 5	6.0			6.0		ns

Up/Down binary counter with reset and ripple clock

74F191

AC WAVEFORMS

NOTE: For all waveforms, $V_M = 1.5V$

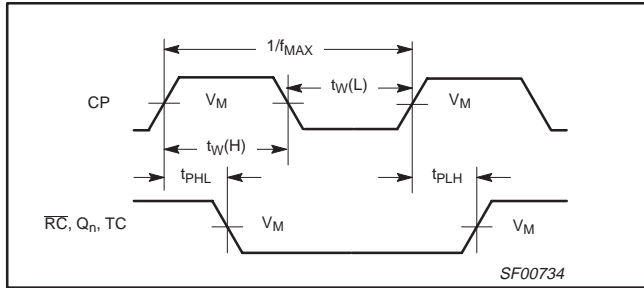

Waveform 1. Propagation Delay, Clock Input to Output, Clock Pulse Width, and Maximum Clock Frequency.

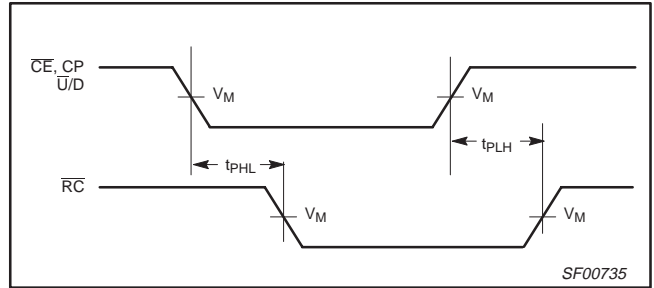

Waveform 2. Propagation Delay, Clock, Clock Enable or Up/Down to Ripple Clock Output

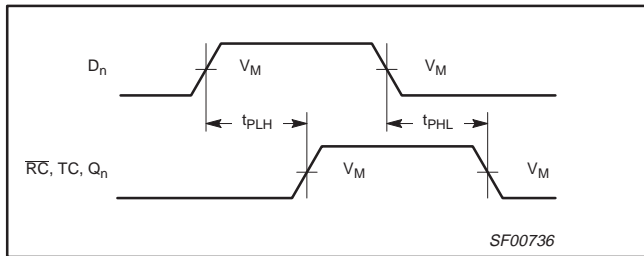

Waveform 3. Propagation Delay, Non-Inverting Path

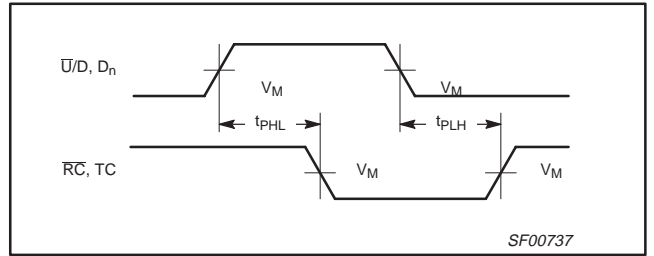

Waveform 4. Propagation Delay, Inverting Path

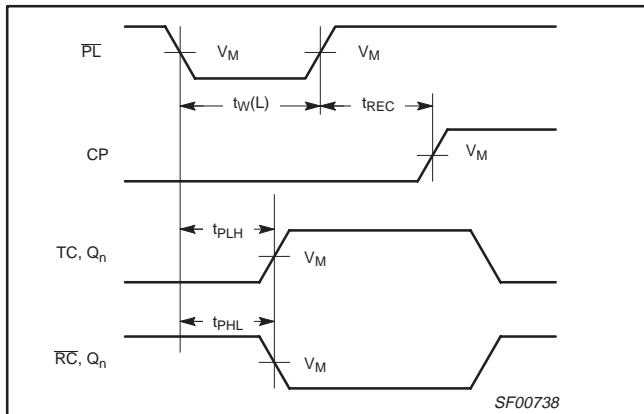

Waveform 5. Parallel Load Pulse Width, Parallel Load to Output Delay and Parallel Load to Clock Recovery Time

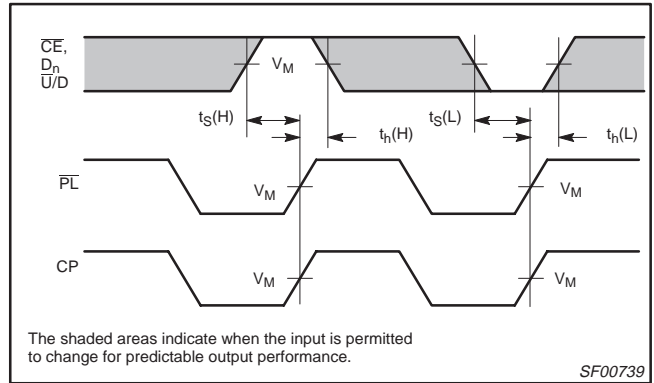

Waveform 6. Data Set Up and Hold Times

Up/Down binary counter with reset and ripple clock

74F191

TEST CIRCUIT AND WAVEFORM

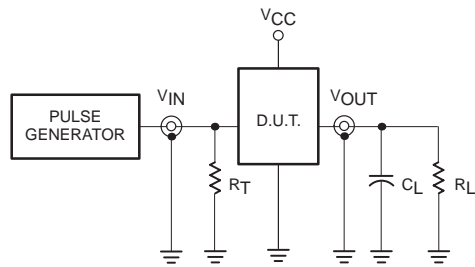

Test Circuit for Totem-Pole Outputs

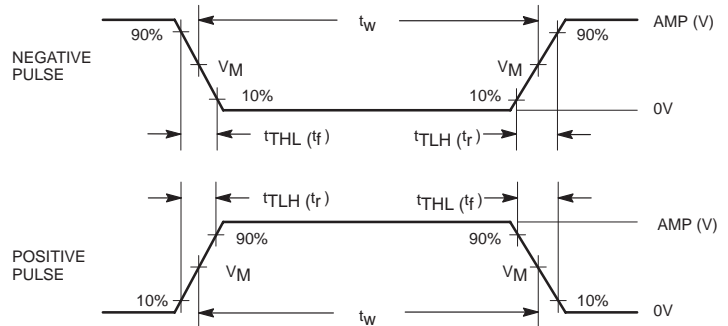

Input Pulse Definition

DEFINITIONS:

- R_L = Load resistor; see AC ELECTRICAL CHARACTERISTICS for value.
- C_L = Load capacitance includes jig and probe capacitance; see AC ELECTRICAL CHARACTERISTICS for value.
- R_T = Termination resistance should be equal to Z_{OUT} of pulse generators.

family	INPUT PULSE REQUIREMENTS					
	amplitude	V_M	rep. rate	t_w	t_{TLH}	t_{THL}
74F	3.0V	1.5V	1MHz	500ns	2.5ns	2.5ns

SF00006

Up/down binary counter with reset and ripple clock

74F191

DIP16: plastic dual in-line package; 16 leads (300 mil)

SOT38-4

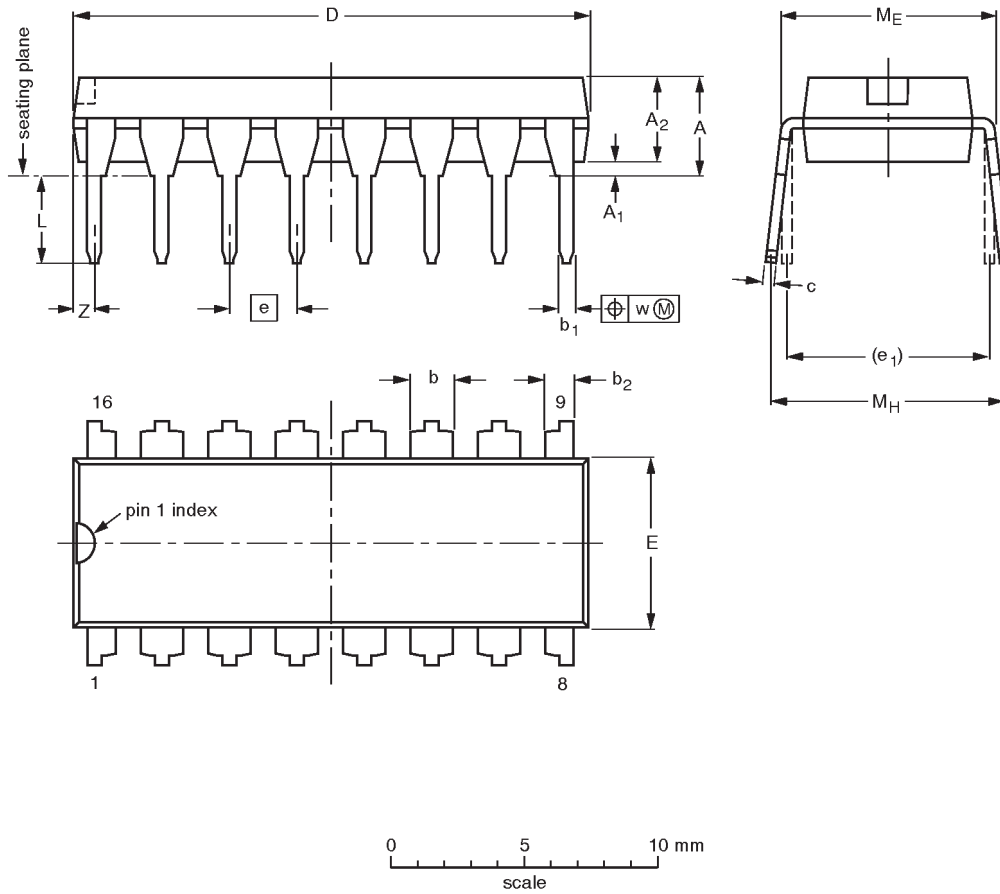

DIMENSIONS (inch dimensions are derived from the original mm dimensions)

UNIT	A max.	A ₁ min.	A ₂ max.	b	b ₁	b ₂	c	D ⁽¹⁾	E ⁽¹⁾	e	e ₁	L	M _E	M _H	w	Z ⁽¹⁾ max.
mm	4.2	0.51	3.2	1.73 1.30	0.53 0.38	1.25 0.85	0.36 0.23	19.50 18.55	6.48 6.20	2.54	7.62	3.60 3.05	8.25 7.80	10.0 8.3	0.254	0.76
inches	0.17	0.020	0.13	0.068 0.051	0.021 0.015	0.049 0.033	0.014 0.009	0.77 0.73	0.26 0.24	0.10	0.30	0.14 0.12	0.32 0.31	0.39 0.33	0.01	0.030

Note

1. Plastic or metal protrusions of 0.25 mm maximum per side are not included.

OUTLINE VERSION	REFERENCES				EUROPEAN PROJECTION	ISSUE DATE
	IEC	JEDEC	EIAJ			
SOT38-4						92-11-17 95-01-14

Up/down binary counter with reset and ripple clock

74F191

SO16: plastic small outline package; 16 leads; body width 3.9 mm

SOT109-1

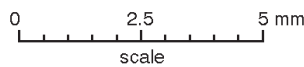
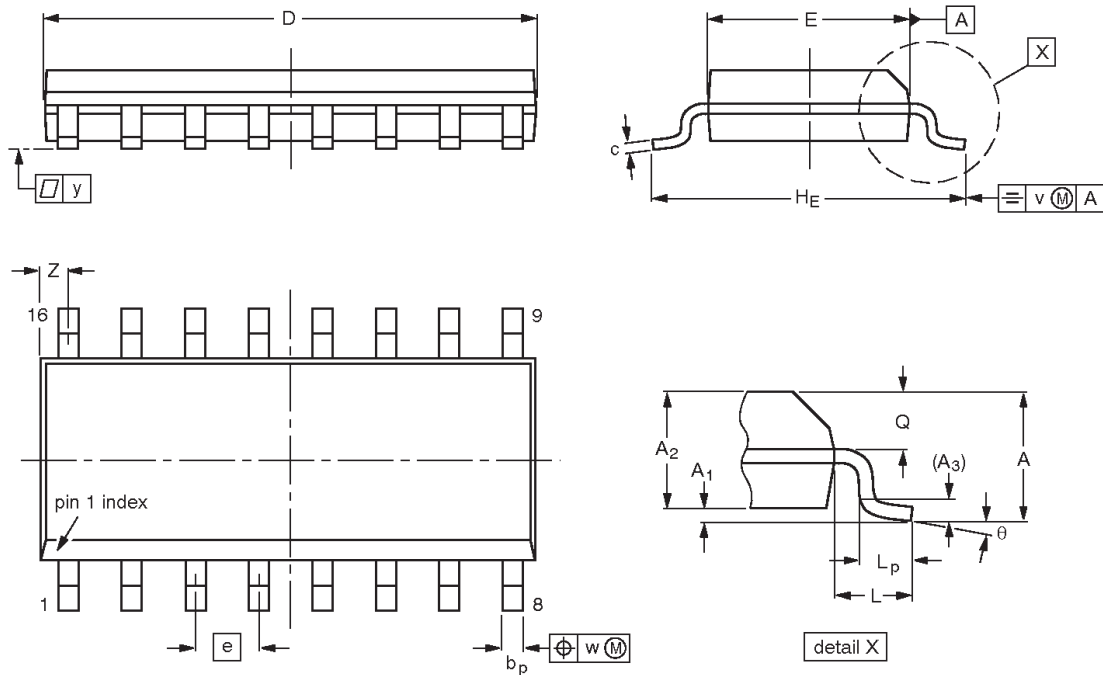

DIMENSIONS (inch dimensions are derived from the original mm dimensions)

UNIT	A max.	A ₁	A ₂	A ₃	b _p	c	D ⁽¹⁾	E ⁽¹⁾	e	H _E	L	L _p	Q	v	w	y	Z ⁽¹⁾	θ
mm	1.75 0.10	0.25 1.25	1.45 0.049	0.25	0.49 0.36	0.25 0.19	10.0 9.8	4.0 3.8	1.27	6.2 5.8	1.05	1.0 0.4	0.7 0.6	0.25	0.25	0.1	0.7 0.3	8° 0°
inches	0.069 0.004	0.010 0.049	0.057 0.014	0.01	0.019 0.014	0.0100 0.0075	0.39 0.38	0.16 0.15	0.050	0.244 0.228	0.041	0.039 0.016	0.028 0.020	0.01	0.01	0.004	0.028 0.012	

Note

1. Plastic or metal protrusions of 0.15 mm maximum per side are not included.

OUTLINE VERSION	REFERENCES				EUROPEAN PROJECTION	ISSUE DATE
	IEC	JEDEC	EIAJ			
SOT109-1	076E07S	MS-012AC				95-01-23 97-05-22

Up/down binary counter with reset and ripple clock

74F191

NOTES

Up/down binary counter with reset and ripple clock

74F191

Data sheet status

Data sheet status	Product status	Definition [1]
Objective specification	Development	This data sheet contains the design target or goal specifications for product development. Specification may change in any manner without notice.
Preliminary specification	Qualification	This data sheet contains preliminary data, and supplementary data will be published at a later date. Philips Semiconductors reserves the right to make changes at any time without notice in order to improve design and supply the best possible product.
Product specification	Production	This data sheet contains final specifications. Philips Semiconductors reserves the right to make changes at any time without notice in order to improve design and supply the best possible product.

[1] Please consult the most recently issued datasheet before initiating or completing a design.

Definitions

Short-form specification — The data in a short-form specification is extracted from a full data sheet with the same type number and title. For detailed information see the relevant data sheet or data handbook.

Limiting values definition — Limiting values given are in accordance with the Absolute Maximum Rating System (IEC 134). Stress above one or more of the limiting values may cause permanent damage to the device. These are stress ratings only and operation of the device at these or at any other conditions above those given in the Characteristics sections of the specification is not implied. Exposure to limiting values for extended periods may affect device reliability.

Application information — Applications that are described herein for any of these products are for illustrative purposes only. Philips Semiconductors make no representation or warranty that such applications will be suitable for the specified use without further testing or modification.

Disclaimers

Life support — These products are not designed for use in life support appliances, devices or systems where malfunction of these products can reasonably be expected to result in personal injury. Philips Semiconductors customers using or selling these products for use in such applications do so at their own risk and agree to fully indemnify Philips Semiconductors for any damages resulting from such application.

Right to make changes — Philips Semiconductors reserves the right to make changes, without notice, in the products, including circuits, standard cells, and/or software, described or contained herein in order to improve design and/or performance. Philips Semiconductors assumes no responsibility or liability for the use of any of these products, conveys no license or title under any patent, copyright, or mask work right to these products, and makes no representations or warranties that these products are free from patent, copyright, or mask work right infringement, unless otherwise specified.

Philips Semiconductors
811 East Arques Avenue
P.O. Box 3409
Sunnyvale, California 94088-3409
Telephone 800-234-7381

© Copyright Philips Electronics North America Corporation 1998
All rights reserved. Printed in U.S.A.

print code

Date of release: 10-98

Document order number:

9397-750-05093

Let's make things better.

Looking for pricing, stock, or lifecycle information?

Click below to explore more details on WIN SOURCE:

 [View N74F191N,602 on WIN SOURCE](#)

 [NXP / Nexperia Information](#)

Optimize Your Supply Chain with WIN SOURCE Solutions

-  Global Sourcing Solution
-  Obsolete Management
-  Cost Control Management
-  Shortage Management
-  Alternative Solution
-  Excess Inventory Management