



**THE DATASHEET OF
74CBTLV16800PAG**





LOW-VOLTAGE 20-BIT BUS SWITCH WITH PRECHARGED OUTPUTS

IDT74CBTLV16800

FEATURES:

- 5Ω A/B bi-directional switch
- Isolation Under Power-Off Conditions
- Over-voltage tolerant
- Latch-up performance exceeds 100mA
- Vcc = 2.3V - 3.6V, normal range
- ESD >2000V per MIL-STD-883, Method 3015; >200V using machine model (C = 200pF, R = 0)
- Available in TSSOP and TVSOP packages

APPLICATIONS:

- 3.3V High Speed Bus Switching and Bus Isolation

DESCRIPTION:

The CBTLV16800 provides 20-bits of high-speed bus switching with low on-state resistance of the switch allowing connections to be made with minimal propagation delay. The device also precharges the B port to a user-selectable bias voltage (BIASV) to minimize live-insertion noise.

The CBTLV16800 is organized as dual 10-bit bus switches with two different output-enable (\overline{OE}) control inputs. When \overline{OE} is low, the corresponding 10-bit bus switch is on and port A is connected to port B. When \overline{OE} is high, the switch is open, and a high impedance state exists between the two ports, and port B is precharged to BIASV through the equivalent of a 10-kΩ resistor.

To ensure the high-impedance state during power up or power down, \overline{OE} should be tied to Vcc through a pullup resistor; the minimum value of the resistor is determined by the current-sinking capability of the driver.

FUNCTIONAL BLOCK DIAGRAM

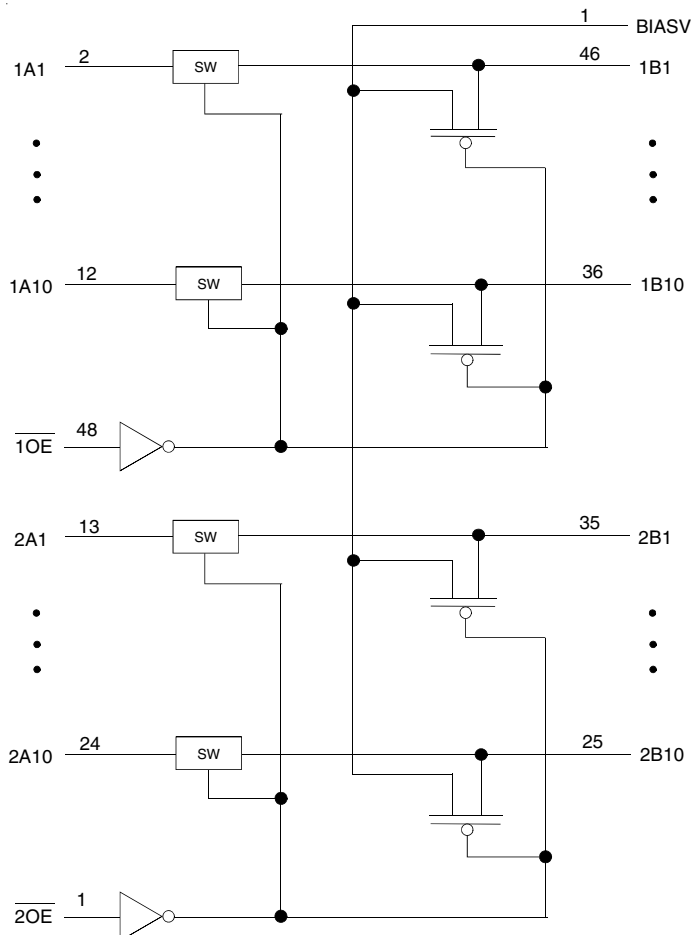

SIMPLIFIED SCHEMATIC, EACH SWITCH

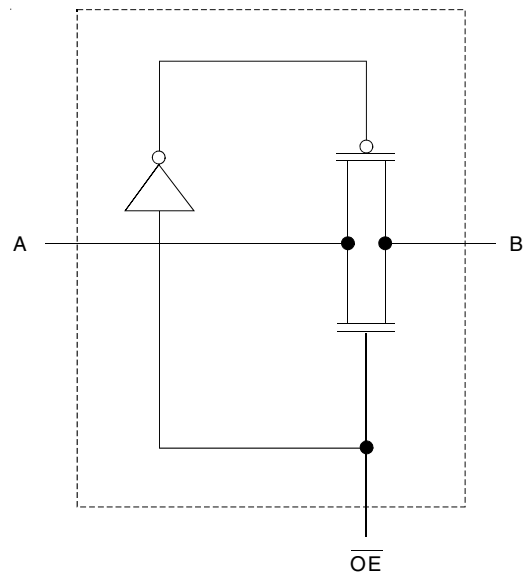

The IDT logo is a registered trademark of Integrated Device Technology, Inc.

INDUSTRIAL TEMPERATURE RANGE

JUNE 2006

PIN CONFIGURATION

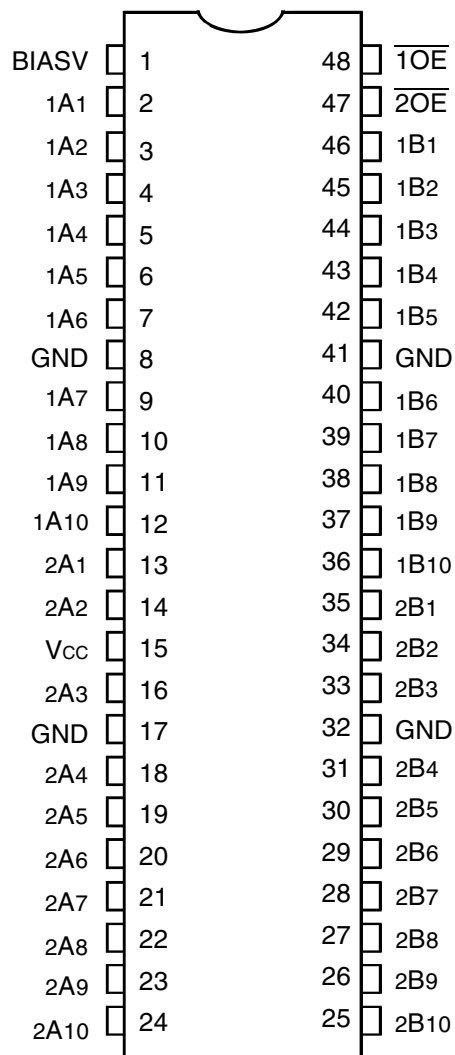

TSSOP/TVSOP
 TOP VIEW

ABSOLUTE MAXIMUM RATINGS⁽¹⁾

Symbol	Description	Max.	Unit
V _{CC}	Supply Voltage Range	-0.5 to 4.6	V
BIASV	Bias Voltage Range, V _I	-0.5 to 4.6	V
V _I	Input Voltage Range	-0.5 to 4.6	V
	Continuous Channel Current	128	mA
I _{IK}	Input Clamp Current, V _{I/O} < 0	-50	mA
T _{STG}	Storage Temperature Range	-65 to +150	°C

NOTE:

- Stresses greater than those listed under ABSOLUTE MAXIMUM RATINGS may cause permanent damage to the device. This is a stress rating only and functional operation of the device at these or any other conditions above those indicated in the operational sections of this specification is not implied. Exposure to absolute maximum rating conditions for extended periods may affect reliability.

FUNCTION TABLE (EACH 10-BIT BUS SWITCH)⁽¹⁾

Input \overline{OE}	Inputs/Outputs
L	A-Port = B-Port
H	A-Port = Z B-Port = BIASV

NOTE:

- H = HIGH Voltage Level
 L = LOW Voltage Level
 Z = High-Impedance

OPERATING CHARACTERISTICS⁽¹⁾

Symbol	Parameter	Test Conditions	Min.	Max.	Unit
V _{CC}	Supply Voltage		2.3	3.6	V
BIASV	Bias Voltage		1.3	V _{CC}	V
V _{IH}	High-Level Control Input Voltage	V _{CC} = 2.3V to 2.7V	1.7	—	V
		V _{CC} = 2.7V to 3.6V	2	—	
V _{IL}	Low-Level Control Input Voltage	V _{CC} = 2.3V to 2.7V	—	0.7	V
		V _{CC} = 2.7V to 3.6V	—	0.8	
T _A	Operating Free-Air Temperature		-40	+85	°C

NOTE:

- All unused control inputs of the device must be held at V_{CC} or GND to ensure proper device operation.

DC ELECTRICAL CHARACTERISTICS OVER OPERATING RANGE

Following Conditions Apply Unless Otherwise Specified:

Operating Condition: TA = -40°C to +85°C

Symbol	Parameter	Test Conditions	Min.	Typ.	Max.	Unit	
V _{IK}	Control Inputs, Data I/O	V _{CC} = 3V, I _I = -18mA	—	—	-1.2	V	
I _I	Control Inputs	V _{CC} = 3.6V, V _I = V _{CC} or GND	—	—	±1	μA	
I _{OZ}	Data I/O	V _{CC} = 3.6V, V _O = 0V or 3.6V switch disabled	—	—	5	μA	
I _{OFF}	A Port	V _{CC} = 0V, V _I or V _O = 0V or 3.6V	—	—	10	μA	
I _O		V _{CC} = 3V, BIASV = 2.4V, V _O = 0, $\overline{OE} = V_{CC}$	0.25	—	—	mA	
I _{CC}		V _{CC} = 3.6V, I _O = 0, V _I = V _{CC} or GND	—	—	10	μA	
ΔI _{CC} ⁽¹⁾	Control Inputs	V _{CC} = 3.6V, one input at 3V, other inputs at V _{CC} or GND	—	—	300	μA	
C _I	Control Inputs	V _I = 3V or 0	—	4	—	pF	
C _{I(OFF)}		V _O = 3V or 0, switch off, BIASV = open, $\overline{OE} = V_{CC}$	—	6.5	—	pF	
R _{ON}	V _{CC} = 2.3V Typ. at V _{CC} = 2.5V	V _I = 0	I _I = 64mA	—	5	9	Ω
			I _I = 24mA	—	5	9	
	V _{CC} = 3V	V _I = 1.7V	I _I = 15mA	—	25	35	
			V _I = 0	I _I = 64mA	—	5	
	V _{CC} = 3V	V _I = 2.4V		I _I = 24mA	—	5	
			I _I = 15mA	—	10	15	

NOTES:

- The increase in supply current is attributable to each input that is at the specified voltage level rather than V_{CC} or GND.
- This is measured by the voltage drop between the A and B terminals at the indicated current through the switch. On-state resistance is determined by the lower of the voltages of the two (A or B) terminals.

SWITCHING CHARACTERISTICS

Symbol	Parameter	V _{CC} = 2.5V ± 0.2V		V _{CC} = 3.3V ± 0.3V		Unit
		Min.	Max.	Min.	Max.	
t _{PD} ⁽¹⁾	Propagation Delay A to B or B to A	—	0.15	—	0.25	ns
t _{PZH}	BIASV = GND \overline{OE} to A or B	2.9	7.7	2.2	5.5	ns
t _{PZL}	BIASV = 3V \overline{OE} to A or B	2.8	6.4	2.1	5.3	ns
t _{PHZ}	BIASV = GND \overline{OE} to A or B	1.4	6.8	2.6	7.6	ns
t _{PLZ}	BIASV = 3V \overline{OE} to A or B	1.3	4.2	1.5	5.1	ns

NOTE:

- The propagation delay is the calculated RC time constant of the typical on-state resistance of the switch and the specified load capacitance when driven by an ideal voltage source (zero output impedance).

TEST CIRCUITS AND WAVEFORMS

TEST CONDITIONS

Symbol	$V_{CC}^{(1)} = 3.3V \pm 0.3V$	$V_{CC}^{(2)} = 2.5V \pm 0.2V$	Unit
V_{LOAD}	6	$2 \times V_{CC}$	V
V_{IH}	3	V_{CC}	V
V_T	1.5	$V_{CC} / 2$	V
V_{LZ}	300	150	mV
V_{HZ}	300	150	mV
C_L	50	30	pF

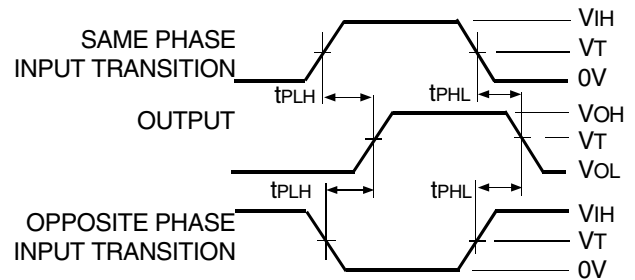

Propagation Delay

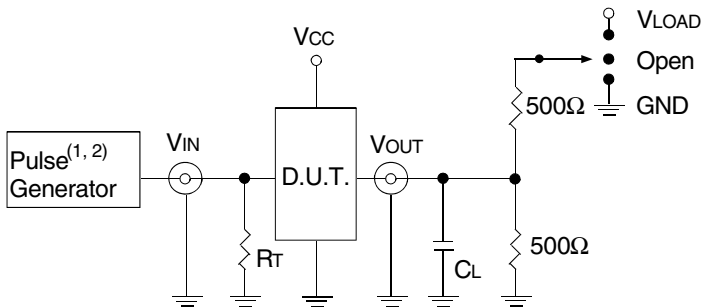

Test Circuits for All Outputs

DEFINITIONS:

C_L = Load capacitance: includes jig and probe capacitance.
 R_T = Termination resistance: should be equal to Z_{OUT} of the Pulse Generator.

NOTES:

1. Pulse Generator for All Pulses: Rate $\leq 10\text{MHz}$; $t_r \leq 2.5\text{ns}$; $t_f \leq 2.5\text{ns}$.
2. Pulse Generator for All Pulses: Rate $\leq 10\text{MHz}$; $t_r \leq 2\text{ns}$; $t_f \leq 2\text{ns}$.

SWITCH POSITION

Test	Switch
t_{PLZ}/t_{PZL}	V_{LOAD}
t_{PHZ}/t_{PZH}	GND
t_{PD}	Open

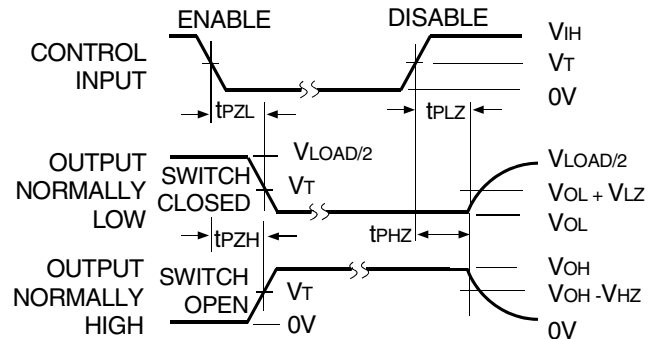

NOTE:

1. Diagram shown for input Control Enable-LOW and input Control Disable-HIGH.

Enable and Disable Times

ORDERING INFORMATION

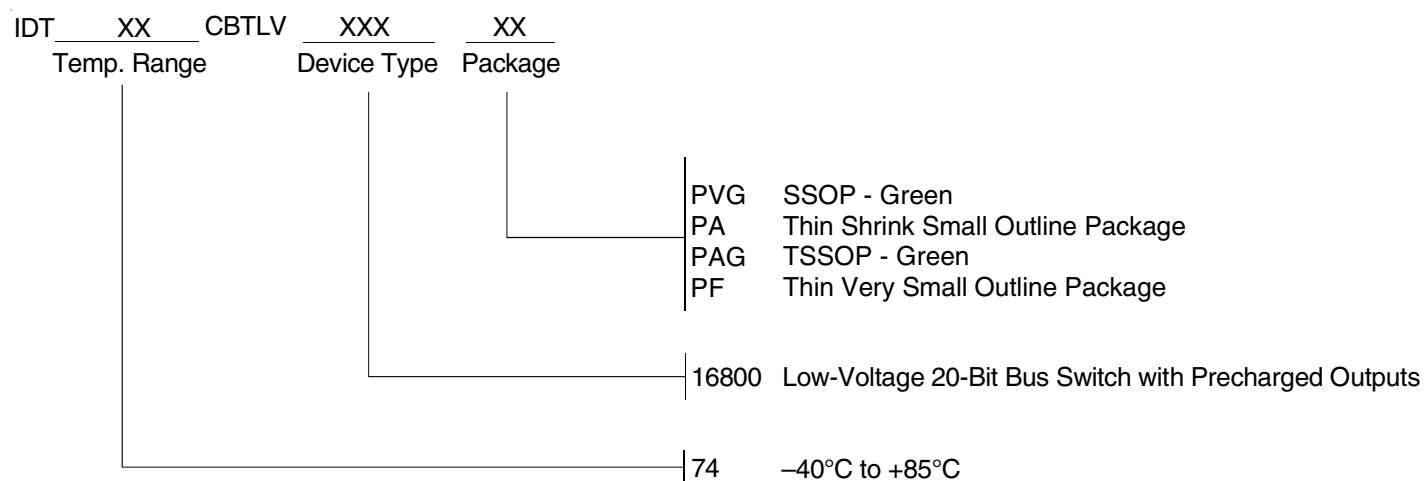

CORPORATE HEADQUARTERS
 6024 Silver Creek Valley Road
 San Jose, CA 95138

for SALES:
 800-345-7015 or 408-284-8200
 fax: 408-284-2775
 www.idt.com

for Tech Support:
 logichelp@idt.com

Looking for pricing, stock, or lifecycle information?

Click below to explore more details on WIN SOURCE:

- ⊖ [View 74CBTLV16800PAG on WIN SOURCE](#)
- ⊖ [IDT, Integrated Device Technology Inc Information](#)

Optimize Your Supply Chain with WIN SOURCE Solutions

- ✓ Global Sourcing Solution
- ✓ Obsolete Management
- ✓ Cost Control Management
- ✓ Shortage Management
- ✓ Alternative Solution
- ✓ Excess Inventory Management