



# THE DATASHEET OF AT91SAM9G45C-CU





#### Description

The ARM926EJ-S based SAM9G45 features the frequently demanded combination of user interface functionality and high data rate connectivity, including LCD Controller, resistive touch-screen, camera interface, audio, Ethernet 10/100 and high speed USB and SDIO. With the processor running at 400 MHz and multiple 100+ Mbps data rate peripherals, the SAM9G45 has the performance and bandwidth to the network or local storage media to provide an adequate user experience.

The SAM9G45 supports DDR2 and NAND Flash memory interfaces for program and data storage. An internal 133 MHz multi-layer bus architecture associated with 37 DMA channels, a dual external bus interface and distributed memory including a 64-Kbyte SRAM which can be configured as a tightly coupled memory (TCM) sustains the high bandwidth required by the processor and the high speed peripherals.

The I/Os support 1.8V or 3.3V operation, which are independently configurable for the memory interface and peripheral I/Os. This feature completely eliminates the need for any external level shifters. In addition it supports 0.8 ball pitch package for low cost PCB manufacturing.

The SAM9G45 power management controller features efficient clock gating and a battery backup section minimizing power consumption in active and standby modes.

This is a summary document.  
The complete document is  
available on the Atmel website  
at [www.atmel.com](http://www.atmel.com).

# 1. Features

- **400 MHz ARM926EJ-S™ ARM® Thumb® Processor**
  - 32 Kbytes Data Cache, 32 Kbytes Instruction Cache, MMU
- **Memories**
  - DDR2 Controller 4-bank DDR2/LPDDR, SDRAM/LPSDR
  - External Bus Interface supporting 4-bank DDR2/LPDDR, SDRAM/LPSDR, Static Memories, CompactFlash, SLC NAND Flash with ECC
  - One 64-Kbyte internal SRAM, single-cycle access at system speed or processor speed through TCM interface
  - One 64-Kbyte internal ROM, embedding bootstrap routine
- **Peripherals**
  - LCD Controller supporting STN and TFT displays up to 1280\*860
  - ITU-R BT. 601/656 Image Sensor Interface
  - USB Device High Speed, USB Host High Speed and USB Host Full Speed with On-Chip Transceiver
  - 10/100 Mbps Ethernet MAC Controller
  - Two High Speed Memory Card Hosts (SDIO, SDCard, MMC)
  - AC'97 controller
  - Two Master/Slave Serial Peripheral Interfaces
  - Two Three-channel 16-bit Timer/Counters
  - Two Synchronous Serial Controllers (I2S mode)
  - Four-channel 16-bit PWM Controller
  - Two Two-wire Interfaces
  - Four USARTs with ISO7816, IrDA, Manchester and SPI modes
  - 8-channel 10-bit ADC with 4-wire Touch Screen support
  - Write Protected Registers
- **System**
  - 133 MHz twelve 32-bit layer AHB Bus Matrix
  - 37 DMA Channels
  - Boot from NAND Flash, SDCard, DataFlash® or serial DataFlash
  - Reset Controller with on-chip Power-on Reset
  - Selectable 32768 Hz Low-power and 12 MHz Crystal Oscillators
  - Internal Low-power 32 kHz RC Oscillator
  - One PLL for the system and one 480 MHz PLL optimized for USB High Speed
  - Two Programmable External Clock Signals
  - Advanced Interrupt Controller and Debug Unit
  - Periodic Interval Timer, Watchdog Timer, Real Time Timer and Real Time Clock
- **I/O**
  - Five 32-bit Parallel Input/Output Controllers
  - 160 Programmable I/O Lines Multiplexed with up to Two Peripheral I/Os with Schmitt trigger input
- **Package**
  - 324-ball TFBGA, pitch 0.8 mm

## 2. Block Diagram

Figure 2-1. SAM9G45 Block Diagram

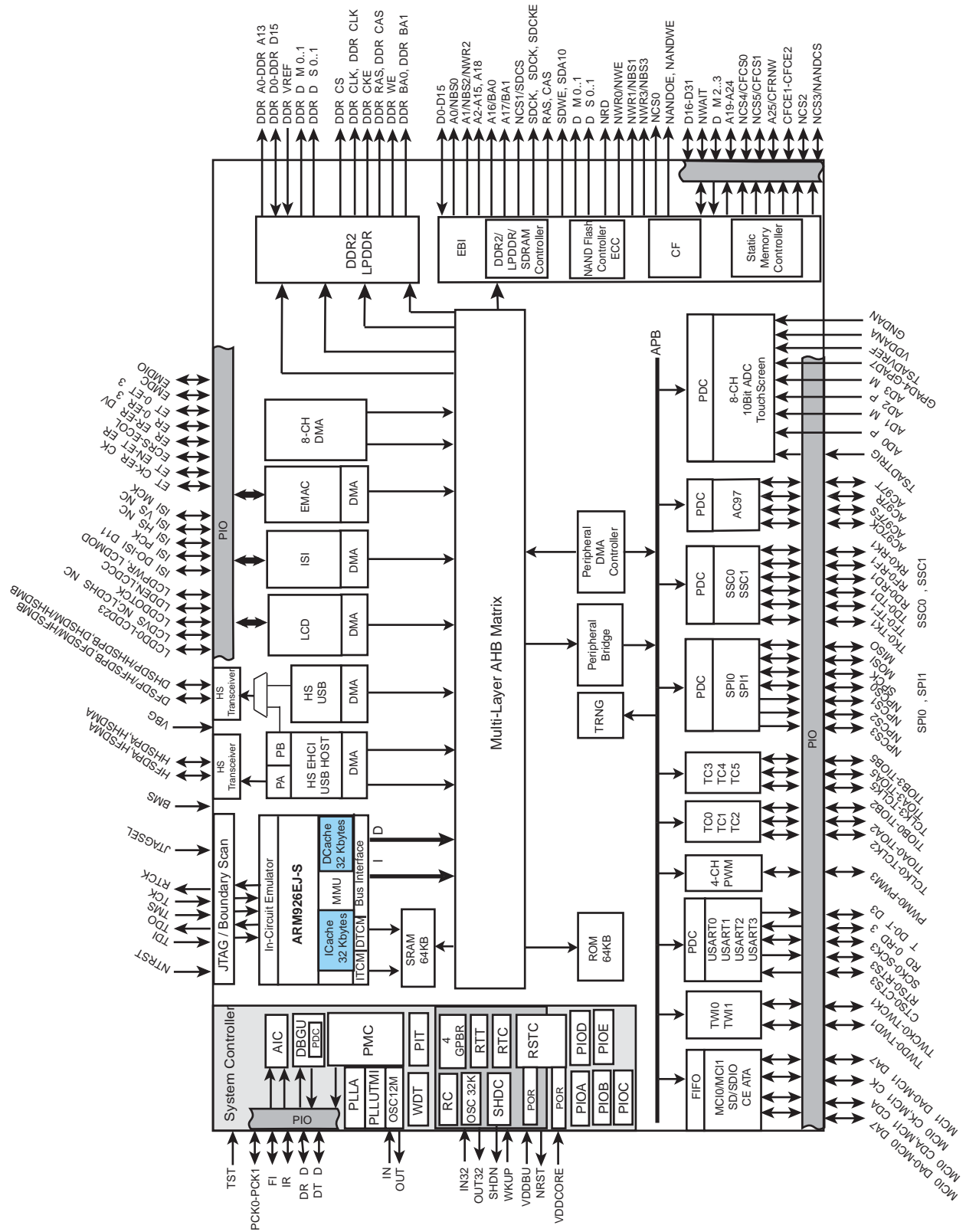

### 3. Signal Description

Table 3-1 gives details on the signal names classified by peripheral.

Table 3-1. Signal Description List

Signal Name	Function	Type	Active Level	Reference Voltage	Comments
<b>Power Supplies</b>					
VDDIOM0	DDR2 I/O Lines Power Supply	Power			1.65V to 1.95V
VDDIOM1	EBI I/O Lines Power Supply	Power			1.65V to 1.95V or 3.0V to 3.6V
VDDIOP0	Peripherals I/O Lines Power Supply	Power			1.65V to 3.6V
VDDIOP1	Peripherals I/O Lines Power Supply	Power			1.65V to 3.6V
VDDIOP2	ISI I/O Lines Power Supply	Power			1.65V to 3.6V
VDDBU	Backup I/O Lines Power Supply	Power			1.8V to 3.6V
VDDANA	Analog Power Supply	Power			3.0V to 3.6V
VDDPLLA	PLLA Power Supply	Power			0.9V to 1.1V
VDDPLLUTMI	PLLUTMI Power Supply	Power			0.9V to 1.1V
VDDOSC	Oscillator Power Supply	Power			1.65V to 3.6V
VDDCORE	Core Chip Power Supply	Power			0.9V to 1.1V
VDDUTMIC	UDPHS and UPHPS UTMI+ Core Power Supply	Power			0.9V to 1.1V
VDDUTMII	UDPHS and UPHPS UTMI+ interface Power Supply	Power			3.0V to 3.6V
GNDIOM	DDR2 and EBI I/O Lines Ground	Ground			
GNDIOP	Peripherals and ISI I/O lines Ground	Ground			
GNDCORE	Core Chip Ground	Ground			
GNDOSC	PLLA, PLLUTMI and Oscillator Ground	Ground			
GNDBU	Backup Ground	Ground			
GNDUTMI	UDPHS and UPHPS UTMI+ Core and interface Ground	Ground			
GNDANA	Analog Ground	Ground			
<b>Clocks, Oscillators and PLLs</b>					
XIN	Main Oscillator Input	Input			
XOUT	Main Oscillator Output	Output			
XIN32	Slow Clock Oscillator Input	Input			
XOUT32	Slow Clock Oscillator Output	Output			
VBG	Bias Voltage Reference for USB	Analog			
PCK0 - PCK1	Programmable Clock Output	Output		(1)	

Table 3-1. Signal Description List (Continued)

Signal Name	Function	Type	Active Level	Reference Voltage	Comments
<b>Shutdown, Wakeup Logic</b>					
SHDN	Shut-Down Control	Output		VDDDBU	Driven at 0V only. 0: The device is in backup mode 1: The device is running (not in backup mode).
WKUP	Wake-Up Input	Input		VDDDBU	Accept between 0V and VDDDBU.
<b>ICE and JTAG</b>					
TCK	Test Clock	Input		VDDIOP0	No pull-up resistor, Schmitt trigger
TDI	Test Data In	Input		VDDIOP0	No pull-up resistor, Schmitt trigger
TDO	Test Data Out	Output		VDDIOP0	
TMS	Test Mode Select	Input		VDDIOP0	No pull-up resistor, Schmitt trigger
JTAGSEL	JTAG Selection	Input		VDDDBU	Pull-down resistor (15 k $\Omega$ ).
RTCK	Return Test Clock	Output		VDDIOP0	
<b>Reset/Test</b>					
NRST	Microcontroller Reset <sup>(2)</sup>	I/O	Low	VDDIOP0	Open-drain output, Pull-Up resistor (100 k $\Omega$ ), Schmitt trigger
TST	Test Mode Select	Input		VDDDBU	Pull-down resistor (15 k $\Omega$ ), Schmitt trigger
NTRST	Test Reset Signal	Input		VDDIOP0	Pull-Up resistor (100 k $\Omega$ ), Schmitt trigger
BMS	Boot Mode Select	Input		VDDIOP0	must be connected to GND or VDDIOP.
<b>Debug Unit - DBGU</b>					
DRXD	Debug Receive Data	Input		(1)	
DTXD	Debug Transmit Data	Output		(1)	
<b>Advanced Interrupt Controller - AIC</b>					
IRQ	External Interrupt Input	Input		(1)	
FIQ	Fast Interrupt Input	Input		(1)	
<b>PIO Controller - PIOA- PIOB - PIOC - PIOD - PIOE</b>					
PA0 - PA31	Parallel IO Controller A	I/O		(1)	Pulled-up input at reset (100k $\Omega$ ) <sup>(3)</sup> , Schmitt trigger
PB0 - PB31	Parallel IO Controller B	I/O		(1)	Pulled-up input at reset (100k $\Omega$ ) <sup>(3)</sup> , Schmitt trigger
PC0 - PC31	Parallel IO Controller C	I/O		(1)	Pulled-up input at reset (100k $\Omega$ ) <sup>(3)</sup> , Schmitt trigger

**Table 3-1. Signal Description List (Continued)**

Signal Name	Function	Type	Active Level	Reference Voltage	Comments
PD0 - PD31	Parallel IO Controller D	I/O		(1)	Pulled-up input at reset (100kΩ) <sup>(3)</sup> , Schmitt trigger
PE0 - PE31	Parallel IO Controller E	I/O		(1)	Pulled-up input at reset (100kΩ) <sup>(3)</sup> , Schmitt trigger
<b>DDR Memory Interface- DDR2/SDRAM/LPDDR Controller</b>					
DDR_D0 - DDR_D15	Data Bus	I/O		VDDIOM0	Pulled-up input at reset
DDR_A0 - DDR_A13	Address Bus	Output		VDDIOM0	0 at reset
DDR_CLK-#DDR_CLK	DDR differential clock input	Output		VDDIOM0	
DDR_CKE	DDR Clock Enable	Output	High	VDDIOM0	
DDR_CS	DDR Chip Select	Output	Low	VDDIOM0	
DDR_WE	DDR Write Enable	Output	Low	VDDIOM0	
DDR_RAS- DDR_CAS	Row and Column Signal	Output	Low	VDDIOM0	
DDR_DQM[0..1]	Write Data Mask	Output		VDDIOM0	
DDR_DQS[0..1]	Data Strobe	Output		VDDIOM0	
DDR_BA0 - DDR_BA1	Bank Select	Output		VDDIOM0	
DDR_VREF	Reference Voltage	Input		VDDIOM0	
<b>External Bus Interface - EBI</b>					
D0 -D31	Data Bus	I/O		VDDIOM1	Pulled-up input at reset
A0 - A25	Address Bus	Output		VDDIOM1	0 at reset
NWAIT	External Wait Signal	Input	Low	VDDIOM1	
<b>Static Memory Controller - SMC</b>					
NCS0 - NCS5	Chip Select Lines	Output	Low	VDDIOM1	
NWR0 - NWR3	Write Signal	Output	Low	VDDIOM1	
NRD	Read Signal	Output	Low	VDDIOM1	
NWE	Write Enable	Output	Low	VDDIOM1	
NBS0 - NBS3	Byte Mask Signal	Output	Low	VDDIOM1	
<b>CompactFlash Support</b>					
CFCE1 - CFCE2	CompactFlash Chip Enable	Output	Low	VDDIOM1	
CFOE	CompactFlash Output Enable	Output	Low	VDDIOM1	
CFWE	CompactFlash Write Enable	Output	Low	VDDIOM1	
CFIOR	CompactFlash IO Read	Output	Low	VDDIOM1	
CFIOW	CompactFlash IO Write	Output	Low	VDDIOM1	
CFRNW	CompactFlash Read Not Write	Output		VDDIOM1	
CFCS0 -CFCS1	CompactFlash Chip Select Lines	Output	Low	VDDIOM1	

**Table 3-1. Signal Description List (Continued)**

Signal Name	Function	Type	Active Level	Reference Voltage	Comments
<b>NAND Flash Support</b>					
NANDCS	NAND Flash Chip Select	Output	Low	VDDIOM1	
NANDOE	NAND Flash Output Enable	Output	Low	VDDIOM1	
NANDWE	NAND Flash Write Enable	Output	Low	VDDIOM1	
<b>DDR2/SDRAM/LPDDR Controller</b>					
SDCK,#SDCK	DDR2/SDRAM differential clock	Output		VDDIOM1	
SDCKE	DDR2/SDRAM Clock Enable	Output	High	VDDIOM1	
SDCS	DDR2/SDRAM Controller Chip Select	Output	Low	VDDIOM1	
BA0 - BA1	Bank Select	Output		VDDIOM1	
SDWE	DDR2/SDRAM Write Enable	Output	Low	VDDIOM1	
RAS - CAS	Row and Column Signal	Output	Low	VDDIOM1	
SDA10	SDRAM Address 10 Line	Output		VDDIOM1	
DQS[0..1]	Data Strobe	Output		VDDIOM1	
DQM[0..3]	Write Data Mask	Output		VDDIOM1	
<b>High Speed Multimedia Card Interface - HSMCIx</b>					
MCIx_CK	Multimedia Card Clock	I/O		(1)	
MCIx_CDA	Multimedia Card Slot A Command	I/O		(1)	
MCIx_DA0 - MCIx_DA7	Multimedia Card Slot A Data	I/O		(1)	
<b>Universal Synchronous Asynchronous Receiver Transmitter - USARTx</b>					
SCKx	USARTx Serial Clock	I/O		(1)	
TXDx	USARTx Transmit Data	Output		(1)	
RXDx	USARTx Receive Data	Input		(1)	
RTSx	USARTx Request To Send	Output		(1)	
CTSx	USARTx Clear To Send	Input		(1)	
<b>Synchronous Serial Controller - SSCx</b>					
TDx	SSC Transmit Data	Output		(1)	
RDx	SSC Receive Data	Input		(1)	
TKx	SSC Transmit Clock	I/O		(1)	
RKx	SSC Receive Clock	I/O		(1)	
TFx	SSC Transmit Frame Sync	I/O		(1)	
RFx	SSC Receive Frame Sync	I/O		(1)	

**Table 3-1. Signal Description List (Continued)**

Signal Name	Function	Type	Active Level	Reference Voltage	Comments
<b>AC97 Controller - AC97C</b>					
AC97RX	AC97 Receive Signal	Input		(1)	
AC97TX	AC97 Transmit Signal	Output		(1)	
AC97FS	AC97 Frame Synchronization Signal	Output		(1)	
AC97CK	AC97 Clock signal	Input		(1)	
<b>Time Counter - TCx</b>					
TCLKx	TC Channel x External Clock Input	Input		(1)	
TIOAx	TC Channel x I/O Line A	I/O		(1)	
TIOBx	TC Channel x I/O Line B	I/O		(1)	
<b>Pulse Width Modulation Controller - PWM</b>					
PWMx	Pulse Width Modulation Output	Output		(1)	
<b>Serial Peripheral Interface - SPIx_</b>					
SPIx_MISO	Master In Slave Out	I/O		(1)	
SPIx_MOSI	Master Out Slave In	I/O		(1)	
SPIx_SPCK	SPI Serial Clock	I/O		(1)	
SPIx_NPCS0	SPI Peripheral Chip Select 0	I/O	Low	(1)	
SPIx_NPCS1- SPIx_NPCS3	SPI Peripheral Chip Select	Output	Low	(1)	
<b>Two-Wire Interface</b>					
TWDx	Two-wire Serial Data	I/O		(1)	
TWCKx	Two-wire Serial Clock	I/O		(1)	
<b>USB Host High Speed Port - UHPHS</b>					
HFSDPA	USB Host Port A Full Speed Data +	Analog		VDDUTMII	
HFSDMA	USB Host Port A Full Speed Data -	Analog		VDDUTMII	
HHSDPA	USB Host Port A High Speed Data +	Analog		VDDUTMII	
HHSDMA	USB Host Port A High Speed Data -	Analog		VDDUTMII	
HFSDPB	USB Host Port B Full Speed Data +	Analog		VDDUTMII	Multiplexed with DFSDP
HFSDMB	USB Host Port B Full Speed Data -	Analog		VDDUTMII	Multiplexed with DFSDM
HHSDPB	USB Host Port B High Speed Data +	Analog		VDDUTMII	Multiplexed with DHSDP
HHSDMB	USB Host Port B High Speed Data -	Analog		VDDUTMII	Multiplexed with DHSDM
<b>USB Device High Speed Port - UDPHS</b>					
DFSDM	USB Device Full Speed Data -	Analog		VDDUTMII	
DFSDP	USB Device Full Speed Data +	Analog		VDDUTMII	
DHSDM	USB Device High Speed Data -	Analog		VDDUTMII	
DHSDP	USB Device High Speed Data +	Analog		VDDUTMII	

**Table 3-1. Signal Description List (Continued)**

Signal Name	Function	Type	Active Level	Reference Voltage	Comments
<b>Ethernet 10/100</b>					
ETXCK	Transmit Clock or Reference Clock	Input		(1)	MII only, REFCK in RMII
ERXCK	Receive Clock	Input		(1)	MII only
ETXEN	Transmit Enable	Output		(1)	
ETX0-ETX3	Transmit Data	Output		(1)	ETX0-ETX1 only in RMII
ETXER	Transmit Coding Error	Output		(1)	MII only
ERXDV	Receive Data Valid	Input		(1)	RXDV in MII, CRSDV in RMII
ERX0-ERX3	Receive Data	Input		(1)	ERX0-ERX1 only in RMII
ERXER	Receive Error	Input		(1)	
ECRS	Carrier Sense and Data Valid	Input		(1)	MII only
ECOL	Collision Detect	Input		(1)	MII only
EMDC	Management Data Clock	Output		(1)	
EMDIO	Management Data Input/Output	I/O		(1)	
<b>Image Sensor Interface</b>					
ISI_D0-ISI_D11	Image Sensor Data	Input		VDDIOP2	
ISI_MCK	Image sensor Reference clock	output		VDDIOP2	
ISI_HSYNC	Image Sensor Horizontal Synchro	input		VDDIOP2	
ISI_VSYNC	Image Sensor Vertical Synchro	input		VDDIOP2	
ISI_PCK	Image Sensor Data clock	input		VDDIOP2	
<b>LCD Controller - LCDC</b>					
LCDD0 - LCDD23	LCD Data Bus	Output		VDDIOP1	
LCDVSYNC	LCD Vertical Synchronization	Output		VDDIOP1	
LCDHSYNC	LCD Horizontal Synchronization	Output		VDDIOP1	
LCDDOTCK	LCD Dot Clock	Output		VDDIOP1	
LCDDEN	LCD Data Enable	Output		VDDIOP1	
LCDC	LCD Contrast Control	Output		VDDIOP1	
LCDPWR	LCD panel Power enable control	Output		VDDIOP1	
LCDMOD	LCD Modulation signal	Output		VDDIOP1	
<b>Touch Screen Analog-to-Digital Converter</b>					
AD0X <sub>P</sub>	Analog input channel 0 or Touch Screen Top channel	Analog		VDDANA	Multiplexed with AD0
AD1X <sub>M</sub>	Analog input channel 1 or Touch Screen Bottom channel	Analog		VDDANA	Multiplexed with AD1
AD2Y <sub>P</sub>	Analog input channel 2 or Touch Screen Right channel	Analog		VDDANA	Multiplexed with AD2
AD3Y <sub>M</sub>	Analog input channel 3 or Touch Screen Left channel	Analog		VDDANA	Multiplexed with AD3

**Table 3-1. Signal Description List (Continued)**

Signal Name	Function	Type	Active Level	Reference Voltage	Comments
GPAD4-GPAD7	Analog Inputs	Analog		VDDANA	
TSADTRG	ADC Trigger	Input		VDDANA	
TSADVREF	ADC Reference	Analog		VDDANA	

- Notes:
1. Refer to peripheral multiplexing tables in [Section 9.4 “Peripheral Signals Multiplexing on I/O Lines”](#) for these signals.
  2. When configured as an input, the NRST pin enables asynchronous reset of the device when asserted low. This allows connection of a simple push button on the NRST pin as a system-user reset.
  3. Programming of this pull-up resistor is performed independently for each I/O line through the PIO Controllers. After reset, all the I/O lines default as inputs with pull-up resistors enabled, except those which are multiplexed with the External Bus Interface signals that require to be enabled as Peripheral at reset. This is explicitly indicated in the column “Reset State” of the peripheral multiplexing tables.

## 4. Package and Pinout

The SAM9G45 is delivered in a 324-ball TFBGA package.

### 4.1 Mechanical Overview of the 324-ball TFBGA Package

Figure 4-1 shows the orientation of the 324-ball TFBGA Package

Figure 4-1. Orientation of the 324-ball TFBGA Package

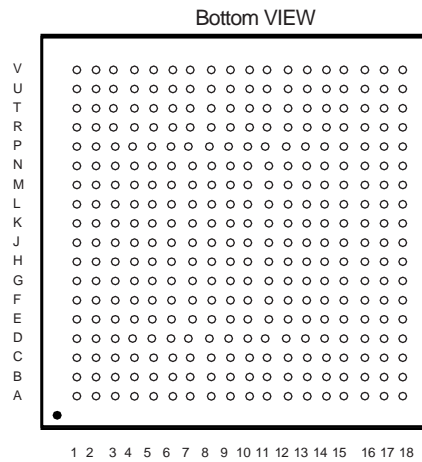

## 4.2 324-ball TFBGA Package Pinout

Table 4-1. SAM9G45 Pinout for 324-ball BGA Package

Pin	Signal Name	Pin	Signal Name	Pin	Signal Name	Pin	Signal Name
A1	PC27	E10	NANDWE	K1	PE21	P10	TMS
A2	PC28	E11	DQS1	K2	PE23	P11	VDDPLLA
A3	PC25	E12	D13	K3	PE26	P12	PB20
A4	PC20	E13	D11	K4	PE22	P13	PB31
A5	PC12	E14	A4	K5	PE24	P14	DDR_D7
A6	PC7	E15	A8	K6	PE25	P15	DDR_D3
A7	PC5	E16	A9	K7	PE27	P16	DDR_D4
A8	PC0	E17	A7	K8	PE28	P17	DDR_D5
A9	NWR3/NBS3	E18	VDDCORE	K9	VDDIOP0	P18	DDR_D10
A10	NCS0	F1	PD22	K10	VDDIOP0	R1	PA18
A11	DQS0	F2	PD24	K11	GNDIOM	R2	PA20
A12	RAS	F3	SHDN	K12	GNDIOM	R3	PA24
A13	SDCK	F4	PE1	K13	VDDIOM0	R4	PA30
A14	NSDCK	F5	PE3	K14	DDR_A7	R5	PB4
A15	D7	F6	VDDIOM1	K15	DDR_A8	R6	PB13
A16	DDR_VREF	F7	PC19	K16	DDR_A9	R7	PD0
A17	D0	F8	PC14	K17	DDR_A11	R8	PD9
A18	A14	F9	PC4	K18	DDR_A10	R9	PD18
B1	PC31	F10	NCS1/SDCS	L1	PA0	R10	TDI
B2	PC29	F11	NRD	L2	PE30	R11	RTCK
B3	PC30	F12	SDWE	L3	PE29	R12	PB22
B4	PC22	F13	A0/NBS0	L4	PE31	R13	PB29
B5	PC17	F14	A1/NBS2/NWR2	L5	PA2	R14	DDR_D6
B6	PC10	F15	A3	L6	PA4	R15	DDR_D1
B7	PC11	F16	A6	L7	PA8	R16	DDR_D0
B8	PC2	F17	A5	L8	PD2	R17	HHSDMA
B9	SDA10	F18	A2	L9	PD13	R18	HFSDMA
B10	A17/BA1	G1	PD25	L10	PD29	T1	PA22
B11	DQM0	G2	PD23	L11	PD31	T2	PA25
B12	SDCKE	G3	PE6	L12	VDDIOM0	T3	PA26
B13	D12	G4	PE0	L13	VDDIOM0	T4	PB0
B14	D8	G5	PE2	L14	DDR_A1	T5	PB6
B15	D4	G6	PE8	L15	DDR_A3	T6	PB16
B16	D3	G7	PE4	L16	DDR_A4	T7	PD1
B17	A15	G8	PE11	L17	DDR_A6	T8	PD11
B18	A13	G9	GNDCORE	L18	DDR_A5	T9	PD19
C1	XIN32	G10	VDDIOM1	M1	PA1	T10	PD30
C2	GNDANA	G11	VDDIOM1	M2	PA5	T11	BMS
C3	WKUP	G12	VDDCORE	M3	PA6	T12	PB8
C4	PC26	G13	VDDCORE	M4	PA7	T13	PB30
C5	PC21	G14	DDR_DQM0	M5	PA10	T14	DDR_D2
C6	PC15	G15	DDR_DQS1	M6	PA14	T15	PB21
C7	PC9	G16	DDR_BA1	M7	PB14	T16	PB23
C8	PC3	G17	DDR_BA0	M8	PD4	T17	HHSDPA
C9	NWRO/NWE	G18	DDR_DQS0	M9	PD15	T18	HFSDPA
C10	A16/BA0	H1	PD26	M10	NRST	U1	PA27
C11	CAS	H2	PD27	M11	PB11	U2	PA29
C12	D15	H3	VDDIOP1	M12	PB25	U3	PA28
C13	D10	H4	PE13	M13	PB27	U4	PB3
C14	D6	H5	PE5	M14	VDDIOM0	U5	PB7

**Table 4-1. SAM9G45 Pinout for 324-ball BGA Package (Continued)**

Pin	Signal Name	Pin	Signal Name	Pin	Signal Name	Pin	Signal Name
C15	D2	H6	PE7	M15	DDR_D14	U6	PB17
C16	GNDIOM	H7	PE9	M16	DDR_D15	U7	PD7
C17	A18	H8	PE10	M17	DDR_A0	U8	PD10
C18	A12	H9	GNDCORE	M18	DDR_A2	U9	PD14
D1	XOUT32	H10	GNDIOP	N1	PA3	U10	TCK
D2	PD20	H11	VDDCORE	N2	PA9	U11	VDDOSC
D3	GNDDBU	H12	GNDIOM	N3	PA12	U12	GNDOSC
D4	VDDDBU	H13	GNDIOM	N4	PA15	U13	PB10
D5	PC24	H14	DDR_CS	N5	PA16	U14	PB26
D6	PC18	H15	DDR_WE	N6	PA17	U15	HHSDPB/DHSDP
D7	PC13	H16	DDR_DQM1	N7	PB18	U16	HHSDMB/DHSMDM
D8	PC6	H17	DDR_CAS	N8	PD6	U17	GNDUTMI
D9	NWR1/NBS1	H18	DDR_NCLK	N9	PD16	U18	VDDUTMIC
D10	NANDOE	J1	PE19	N10	NTRST	V1	PA31
D11	DQM1	J2	PE16	N11	PB9	V2	PB1
D12	D14	J3	PE14	N12	PB24	V3	PB2
D13	D9	J4	PE15	N13	PB28	V4	PB5
D14	D5	J5	PE12	N14	DDR_D13	V5	PB15
D15	D1	J6	PE17	N15	DDR_D8	V6	PD3
D16	VDDIOM1	J7	PE18	N16	DDR_D9	V7	PD5
D17	A11	J8	PE20	N17	DDR_D11	V8	PD12
D18	A10	J9	GNDCORE	N18	DDR_D12	V9	PD17
E1	PD21	J10	GNDCORE	P1	PA11	V10	TDO
E2	TSADVREF	J11	GNDIOP	P2	PA13	V11	XOUT
E3	VDDANA	J12	GNDIOM	P3	PA19	V12	XIN
E4	JTAGSEL	J13	GNDIOM	P4	PA21	V13	VDDPLLUTMI
E5	TST	J14	DDR_A12	P5	PA23	V14	VDDIOP2
E6	PC23	J15	DDR_A13	P6	PB12	V15	HFSDPB/DFSDFP
E7	PC16	J16	DDR_CKE	P7	PB19	V16	HFSDMB/DFSDFM
E8	PC8	J17	DDR_RAS	P8	PD8	V17	VDDUTMII
E9	PC1	J18	DDR_CLK	P9	PD28	V18	VBG

## 5. Power Considerations

### 5.1 Power Supplies

The SAM9G45 has several types of power supply pins:

- VDDCORE pins: Power the core, including the processor, the embedded memories and the peripherals; voltage ranges from 0.9V to 1.1V, 1.0V typical.
- VDDIOM0 pins: Power the DDR2/LPDDR I/O lines; voltage ranges between 1.65V and 1.95V (1.8V typical).
- VDDIOM1 pins: Power the External Bus Interface 1 I/O lines; voltage ranges between 1.65V and 1.95V (1.8V typical) or between 3.0V and 3.6V (3.3V typical).
- VDDIOP0, VDDIOP1, VDDIOP2 pins: Power the Peripherals I/O lines; voltage ranges from 1.65V to 3.6V.
- VDDDBU pin: Powers the Slow Clock oscillator, the internal RC oscillator and a part of the System Controller; voltage ranges from 1.8V to 3.6V.
- VDDPLLUTMI pin: Powers the PLLUTMI cell; voltage range from 0.9V to 1.1V.
- VDDUTMIC pin: Powers the USB device and host UTMI+ core; voltage range from 0.9V to 1.1V, 1.0V typical.
- VDDUTMII pin: Powers the USB device and host UTMI+ interface; voltage range from 3.0V to 3.6V, 3.3V typical.
- VDDPLLA pin: Powers the PLLA cell; voltage ranges from 0.9V to 1.1V.
- VDDOSC pin: Powers the Main Oscillator cells; voltage ranges from 1.65V to 3.6V
- VDDANA pin: Powers the Analog to Digital Converter; voltage ranges from 3.0V to 3.6V, 3.3V typical.

Some supply pins share common ground (GND) pins whereas others have separate grounds.

The respective power/ground pin assignments are as follows:

VDDCORE	GNDCORE
VDDIOM0, VDDIOM1	GNDIOM
VDDIOP0, VDDIOP1, VDDIOP2	GNDIOP
VDDDBU	GNDDBU
VDDUTMIC, VDDUTMII	GNDUTMI
VDDPLLUTMI, VDDPLLA, VDDOSC,	GNDOSC
VDDANA	GNDANA

## 6. Processor and Architecture

### 6.1 ARM926EJ-S Processor

- RISC Processor Based on ARM v5TEJ Architecture with Jazelle technology for Java acceleration
- Two Instruction Sets
  - ARM High-performance 32-bit Instruction Set
  - Thumb High Code Density 16-bit Instruction Set
- DSP Instruction Extensions
- 5-Stage Pipeline Architecture:
  - Instruction Fetch (F)
  - Instruction Decode (D)
  - Execute (E)
  - Data Memory (M)
  - Register Write (W)
- 32-KByte Data Cache, 32-KByte Instruction Cache
  - Virtually-addressed 4-way Associative Cache
  - Eight words per line
  - Write-through and Write-back Operation
  - Pseudo-random or Round-robin Replacement
- Write Buffer
  - Main Write Buffer with 16-word Data Buffer and 4-address Buffer
  - DCache Write-back Buffer with 8-word Entries and a Single Address Entry
  - Software Control Drain
- Standard ARM v4 and v5 Memory Management Unit (MMU)
  - Access Permission for Sections
  - Access Permission for large pages and small pages can be specified separately for each quarter of the page
  - 16 embedded domains
- Bus Interface Unit (BIU)
  - Arbitrates and Schedules AHB Requests
  - Separate Masters for both instruction and data access providing complete Matrix system flexibility
  - Separate Address and Data Buses for both the 32-bit instruction interface and the 32-bit data interface
  - On Address and Data Buses, data can be 8-bit (Bytes), 16-bit (Half-words) or 32-bit (Words)
- TCM Interface

## 6.2 Bus Matrix

- 12-layer Matrix, handling requests from 11 masters
- Programmable Arbitration strategy
  - Fixed-priority Arbitration
  - Round-Robin Arbitration, either with no default master, last accessed default master or fixed default master
- Burst Management
  - Breaking with Slot Cycle Limit Support
  - Undefined Burst Length Support
- One Address Decoder provided per Master
  - Three different slaves may be assigned to each decoded memory area: one for internal ROM boot, one for internal flash boot, one after remap
- Boot Mode Select
  - Non-volatile Boot Memory can be internal ROM or external memory on EBI\_NCS0
  - Selection is made by General purpose NVM bit sampled at reset
- Remap Command
  - Allows Remapping of an Internal SRAM in Place of the Boot Non-Volatile Memory (ROM or External Flash)
  - Allows Handling of Dynamic Exception Vectors

### 6.2.1 Matrix Masters

The Bus Matrix of the SAM9G45 manages Masters, thus each master can perform an access concurrently with others, depending on whether the slave it accesses is available.

Each Master has its own decoder, which can be defined specifically for each master. In order to simplify the addressing, all the masters have the same decodings.

**Table 6-1. List of Bus Matrix Masters**

Master 0	ARM926™ Instruction
Master 1	ARM926 Data
Master 2	Peripheral DMA Controller (PDC)
Master 3	USB HOST OHCI
Master 4	DMA
Master 5	DMA
Master 6	ISI Controller DMA
Master 7	LCD DMA
Master 8	Ethernet MAC DMA
Master 9	USB Device High Speed DMA
Master 10	USB Host High Speed EHCI DMA

## 6.2.2 Matrix Slaves

Each Slave has its own arbiter, thus allowing a different arbitration per Slave to be programmed.

**Table 6-2. List of Bus Matrix Slaves**

Slave 0	Internal SRAM
Slave 1	Internal ROM
	USB OHCI
	USB EHCI
	UDP High Speed RAM
	LCD User Interface
Slave 2	DDR Port 0
Slave 3	DDR Port 1
Slave 4	DDR Port 2
Slave 5	DDR Port 3
Slave 6	External Bus Interface
Slave 7	Internal Peripherals

## 6.2.3 Masters to Slaves Access

All the Masters can normally access all the Slaves. However, some paths do not make sense, such as allowing access from the Ethernet MAC to the internal peripherals. Thus, these paths are forbidden or simply not wired, and shown “-” in the following tables.

The four DDR ports are connected differently according to the application device.

The user can disable the DDR multi-port in the DDR multi-port Register (bit DDRMP\_DIS) in the Chip Configuration User Interface.

- When the DDR multi-port is enabled (DDRMP\_DIS=0), the ARM instruction and data are respectively connected to DDR Port 0 and DDR Port 1. The other masters share DDR Port 2 and DDR Port 3.
- When the DDR multi-port is disabled (DDRMP\_DIS=1), DDR Port 1 is dedicated to the LCD controller. The remaining masters share DDR Port 2 and DDR Port 3.

Figure 6-1. DDR Multi-port

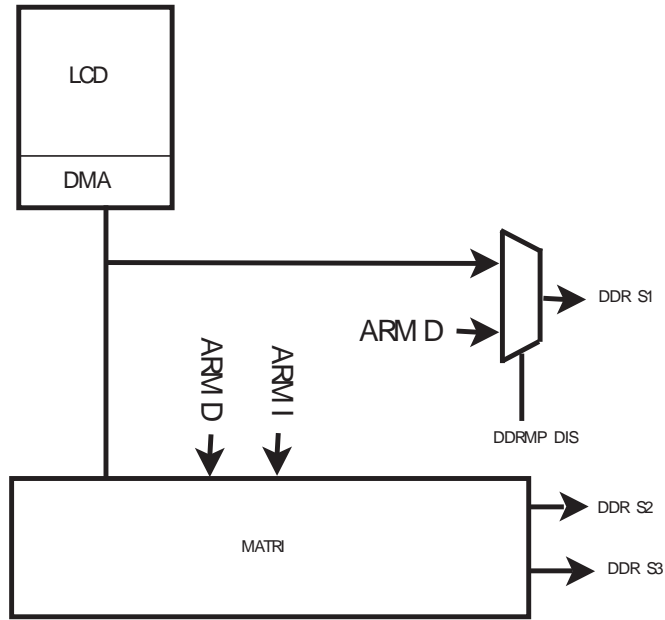

Table 6-3. SAM9G45 Masters to Slaves Access DDRMP\_DIS = 0

Master		0	1	2	3	4 & 5	6	7	8	9	10	11
Slave		ARM 926 Instr.	ARM 926 Data	PDC	USB Host OHCI	DMA	ISI DMA	LCD DMA	Ethernet MAC	USB Device HS	USB Host EHCI	Reserved
0	Internal SRAM 0	X	X	X	X	X	X	-	X	X	X	-
1	Internal ROM	X	X	X	-	-	-	-	-	X	-	-
	UHP OHCI	X	X	-	-	-	-	-	-	-	-	-
	UHP EHCI	X	X	-	-	-	-	-	-	-	-	-
	LCD User Int.	X	X	-	-	-	-	-	-	-	-	-
	UDPHS RAM	X	X	-	-	-	-	-	-	-	-	-
	Reserved	X	X	-	-	-	-	-	-	-	-	-
2	DDR Port 0	X	-	-	-	-	-	-	-	-	-	-
3	DDR Port 1	-	X	-	-	-	-	-	-	-	-	-
4	DDR Port 2	-	-	X	X	X	X	-	X	X	X	X
5	DDR Port 3	-	-	X	X	X	X	X	X	X	X	-
6	EBI	X	X	X	X	X	X	X	X	X	X	X
7	Internal Periph.	X	X	X	-	X	-	-	-	-	-	-

**Table 6-4. SAM9G45 Masters to Slaves Access with DDRMP\_DIS = 1 (default)**

Master		0	1	2	3	4 & 5	6	7	8	9	10	11
Slave		ARM 926 Instr.	ARM 926 Data	PDC	USB HOST OHCI	DMA	ISI DMA	LCD DMA	Ethernet MAC	USB Device HS	USB Host EHCI	Reserved
0	Internal SRAM 0	X	X	X	X	X	X	-	X	X	X	-
1	Internal ROM	X	X	X	-	-	-	-	-	X	-	-
	UHP OHCI	X	X	-	-	-	-	-	-	-	-	-
	UHP EHCI	X	X	-	-	-	-	-	-	-	-	-
	LCD User Int.	X	X	-	-	-	-	-	-	-	-	-
	UDPHS RAM	X	X	-	-	-	-	-	-	-	-	-
	Reserved	X	X	-	-	-	-	-	-	-	-	-
2	DDR Port 0	-	-	-	-	-	-	-	-	-	-	X
3	DDR Port 1	-	-	-	-	-	-	X	-	-	-	-
4	DDR Port 2	X	-	X	X	X	X	-	X	X	X	-
5	DDR Port 3	-	X	X	X	X	X	-	X	X	X	-
6	EBI	X	X	X	X	X	X	X	X	X	X	X
7	Internal Periph.	X	X	X	-	X	-	-	-	-	-	-

Table 6-5 summarizes the Slave Memory Mapping for each connected Master, depending on the Remap status (RCBx bit in Bus Matrix Master Remap Control Register MATRIX\_MRCR) and the BMS state at reset.

**Table 6-5. Internal Memory Mapping**

Slave Base Address	Master		
	RCBx = 0		RCBx = 1
	BMS = 1	BMS = 0	
0x0000 0000	Internal ROM	EBI NCS0	Internal SRAM

## 6.3 Peripheral DMA Controller (PDC)

- Acting as one AHB Bus Matrix Master
- Allows data transfers from/to peripheral to/from any memory space without any intervention of the processor.
- Next Pointer support, prevents strong real-time constraints on buffer management.

The Peripheral DMA Controller handles transfer requests from the channel according to the following priorities (Low to High priorities):

**Table 6-6. Peripheral DMA Controller**

Instance name	Channel T/R
DBGU	Transmit
USART3	Transmit
USART2	Transmit
USART1	Transmit
USART0	Transmit
AC97C	Transmit
SPI1	Transmit
SPI0	Transmit
SSC1	Transmit
SSC0	Transmit
TSADCC	Receive
DBGU	Receive
USART3	Receive
USART2	Receive
USART1	Receive
USART0	Receive
AC97C	Receive
SPI1	Receive
SPI0	Receive
SSC1	Receive
SSC0	Receive

## 6.4 USB

The SAM9G45 features USB communication ports as follows:

- 2 Ports USB Host full speed OHCI and High speed EHCI
- 1 Device High speed

USB Host Port A is directly connected to the first UTMI transceiver.

The Host Port B is multiplexed with the USB device High speed and connected to the second UTMI port. The selection between Host Port B and USB device high speed is controlled by a the bit UDPHS enable bit located in the UDPHS\_CTRL control register.

**Figure 6-2. USB Selection**

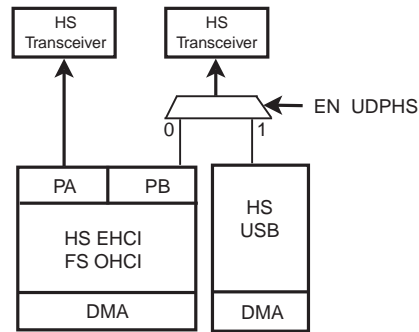

## 6.5 DMA Controller

- Two Masters
- Embeds 8 channels
- 64 bytes/FIFO for Channel Buffering
- Linked List support with Status Write Back operation at End of Transfer
- Word, HalfWord, Byte transfer support.
- memory to memory transfer
- Peripheral to memory
- Memory to peripheral

The DMA controller can handle the transfer between peripherals and memory and so receives the triggers from the peripherals below. The hardware interface numbers are also given below in [Table 6-7](#).

**Table 6-7. DMA Channel Definition**

Instance Name	T/R	DMA Channel HW interface Number
MCI0	TX/RX	0
SPI0	TX	1
SPI0	RX	2
SPI1	TX	3
SPI1	RX	4
SSC0	TX	5
SSC0	RX	6
SSC1	TX	7
SSC1	RX	8
AC97C	TX	9
AC97C	RX	10
MCI1	TX/RX	13

## 6.6 Debug and Test Features

- ARM926 Real-time In-circuit Emulator
  - Two real-time Watchpoint Units
  - Two Independent Registers: Debug Control Register and Debug Status Register
  - Test Access Port Accessible through JTAG Protocol
  - Debug Communications Channel
- Debug Unit
  - Two-pin UART
  - Debug Communication Channel Interrupt Handling
  - Chip ID Register
- IEEE1149.1 JTAG Boundary-scan on All Digital Pins.

# 7. Memories

Figure 7-1. SAM9G45 Memory Mapping

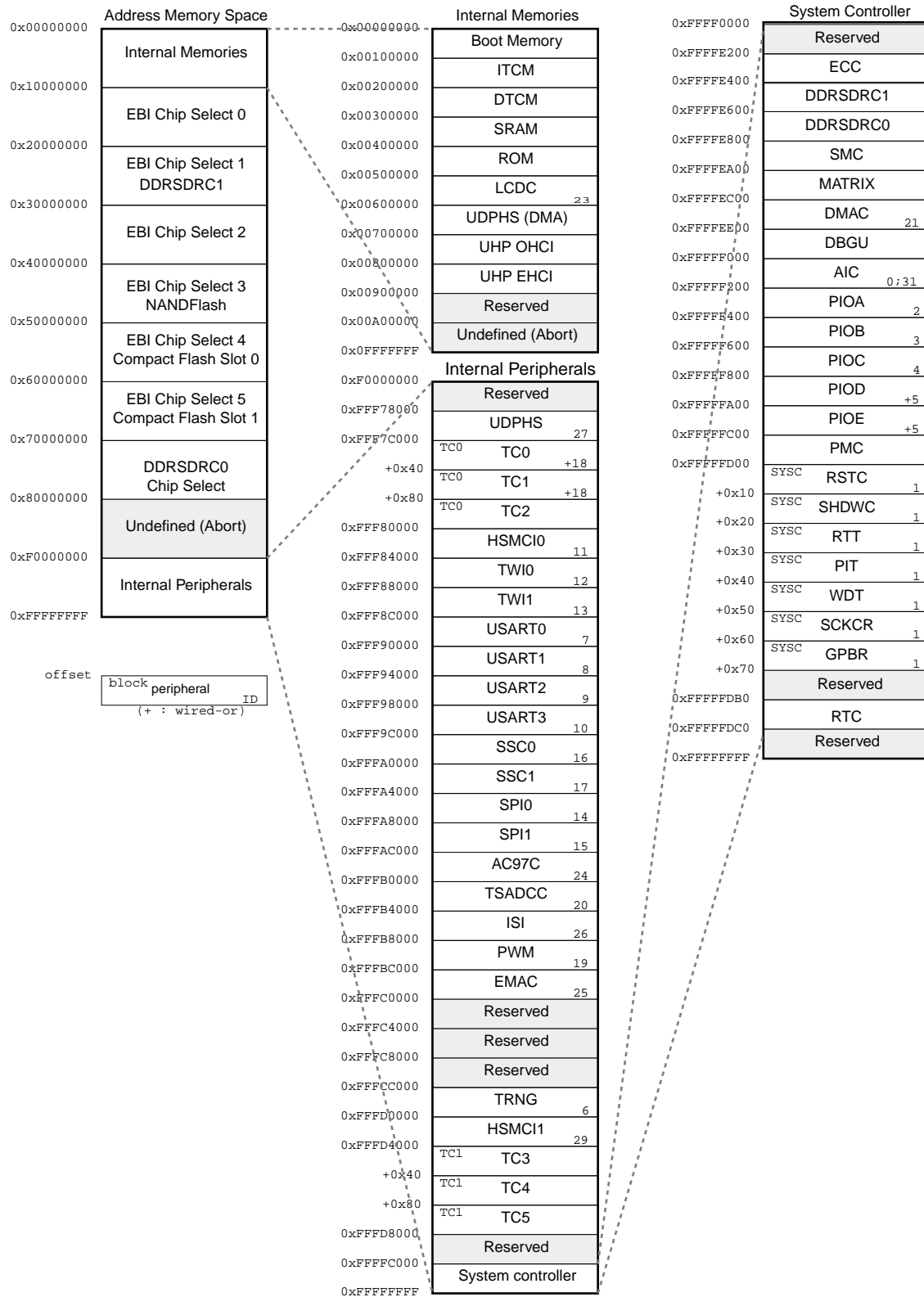

## 7.1 Memory Mapping

A first level of address decoding is performed by the AHB Bus Matrix, i.e., the implementation of the Advanced High performance Bus (AHB) for its Master and Slave interfaces with additional features.

Decoding breaks up the 4 Gbytes of address space into 16 banks of 256 Mbytes. The banks 1 to 6 are directed to the EBI that associates these banks to the external chip selects NCS0 to NCS5.

The bank 7 is directed to the DDRSDRC0 that associates this bank to DDR\_NCS chip select and so dedicated to the 4-port DDR2/LPDDR controller.

The bank 0 is reserved for the addressing of the internal memories, and a second level of decoding provides 1 Mbyte of internal memory area. The bank 15 is reserved for the peripherals and provides access to the Advanced Peripheral Bus (APB).

Other areas are unused and performing an access within them provides an abort to the master requesting such an access.

## 7.2 Embedded Memories

### 7.2.1 Internal SRAM

The SAM9G45 product embeds a total of 64 Kbytes high-speed SRAM split in 4 blocks of 16 KBytes connected to one slave of the matrix. After reset and until the Remap Command is performed, the four SRAM blocks are contiguous and only accessible at address 0x00300000. After Remap, the SRAM also becomes available at address 0x0.

Figure 7-2. Internal SRAM Reset

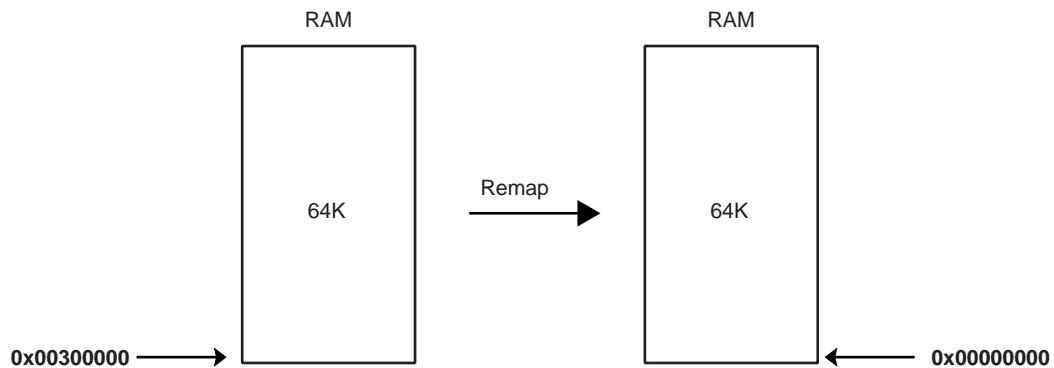

The SAM9G45 device embeds two memory features. The processor Tightly Coupled Memory Interface (TCM) that allows the processor to access the memory up to processor speed (PCK) and the interface on the AHB side allowing masters to access the memory at AHB speed (MCK).

A wait state is necessary to access the TCM at 400 MHz. Setting the bit NWS\_TCM in the bus Matrix TCM Configuration Register of the matrix inserts a wait state on the ITCM and DTCM accesses.

### 7.2.2 TCM Interface

On the processor side, this Internal SRAM can be allocated to two areas.

- Internal SRAM A is the ARM926EJ-S Instruction TCM. The user can map this SRAM block anywhere in the ARM926 instruction memory space using CP15 instructions and the TCR configuration register located in the Chip Configuration User Interface. This SRAM block is also accessible by the ARM926 Masters and by the AHB Masters through the AHB bus

- Internal SRAM B is the ARM926EJ-S Data TCM. The user can map this SRAM block anywhere in the ARM926 data memory space using CP15 instructions. This SRAM block is also accessible by the ARM926 Data Master and by the AHB Masters through the AHB bus.
- Internal SRAM C is only accessible by all the AHB Masters. After reset and until the Remap Command is performed, this SRAM block is accessible through the AHB bus at address 0x0030 0000 by all the AHB Masters. After Remap, this SRAM block also becomes accessible through the AHB bus at address 0x0 by the ARM926 Instruction and the ARM926 Data Masters.

Within the 64 Kbyte SRAM size available, the amount of memory assigned to each block is software programmable according to [Table 7-1](#).

**Table 7-1. ITCM and DTCM Memory Configuration**

SRAM A ITCM size (KBytes) seen at 0x100000 through AHB	SRAM B DTCM size (KBytes) seen at 0x200000 through AHB	SRAM C (KBytes) seen at 0x300000 through AHB
0	0	64
0	64	0
32	32	0

### 7.2.3 Internal ROM

The SAM9G45 embeds an Internal ROM, which contains the Boot ROM and SAM-BA program.

At any time, the ROM is mapped at address 0x0040 0000. It is also accessible at address 0x0 (BMS =1) after the reset and before the Remap Command.

### 7.2.4 Boot Strategies

The system always boots at address 0x0. To ensure maximum boot possibilities the memory layout can be changed with two parameters.

REMAP allows the user to layout the internal SRAM bank to 0x0 to ease the development. This is done by software once the system has boot.

BMS allows the user to lay out to 0x0, when convenient, the ROM or an external memory. This is done by a hardware way at reset.

Note: All the memory blocks can always be seen at their specified base addresses that are not concerned by these parameters.

The SAM9G45 Bus Matrix manages a boot memory that depends on the level on the pin BMS at reset. The internal memory area mapped between address 0x0 and 0x000F FFFF is reserved to this effect.

If BMS is detected at 1, the boot memory is the embedded ROM.

If BMS is detected at 0, the boot memory is the memory connected on the Chip Select 0 of the External Bus Interface.

#### 7.2.4.1 BMS = 1, boot on embedded ROM

The system boots on Boot Program.

- Boot on on-chip RC
- Enable the 32768 Hz oscillator
- Auto baudrate detection
- Downloads and runs an application from external storage media into internal SRAM
- Downloaded code size depends on embedded SRAM size
- Automatic detection of valid application

- Bootloader on a non-volatile memory
  - SPI DataFlash/Serial Flash connected on NPC0 of the SPI0
  - SDCard
  - Nand Flash
  - EEPROM connected on TWI0
- SAM-BA Boot in case no valid program is detected in external NVM, supporting
  - Serial communication on a DBGU
  - USB Device HS Port

#### 7.2.4.2 BMS = 0, boot on external memory

- Boot on on-chip RC
- Boot with the default configuration for the Static Memory Controller, byte select mode, 16-bit data bus, Read/Write controlled by Chip Select, allows boot on 16-bit non-volatile memory.

For optimization purpose, nothing else is done. To speed up the boot sequence user programmed software should perform a complete configuration:

- Enable the 32768 Hz oscillator if best accuracy needed
- Program the PMC (main oscillator enable or bypass mode)
- Program and Start the PLL
- Reprogram the SMC setup, cycle, hold, mode timings registers for EBI CS0 to adapt them to the new clock
- Switch the main clock to the new value

## 7.3 External Memories

The SAM9G45 features a Multi-port DDR2 Interface and an External Bus Interface allowing to connect to a wide range of external memories and to any parallel peripheral.

### 7.3.1 DDRSDRC0 Multi-port DDRSDR Controller

Four AHB Interfaces, Management of All Accesses Maximizes Memory Bandwidth and Minimizes Transaction Latency.

- Supports AHB Transfers:
  - Word, Half Word, Byte Access.
- Supports DDR2, LPDDR
- Numerous Configurations Supported
  - 2K, 4K, 8K, 16K Row Address Memory Parts
  - DDR2 with Four Internal Banks
  - DDR2/LPDDR with 16-bit Data Path
  - One Chip Select for DDR2/LPDDR Device (256 Mbytes Address Space)
- Programming Facilities
  - Multibank Ping-pong Access (Up to 4 Banks Opened at Same Time = Reduces Average Latency of Transactions)
  - Timing Parameters Specified by Software
  - Automatic Refresh Operation, Refresh Rate is Programmable
  - Automatic Update of DS, TCR and PASR Parameters
- Energy-saving Capabilities
  - Self-refresh, Power-down and Deep Power Modes Supported
- Power-up Initialization by Software
- CAS Latency of 2, 3 Supported
- Reset function supported (DDR2)
- Auto Precharge Command Not Used

- On Die Termination not supported
- OCD mode not supported

### 7.3.2 External Bus Interface

- Integrates Three External Memory Controllers:
  - Static Memory Controller
  - DDR2/SDRAM Controller
  - SLC Nand Flash ECC Controller
- Additional logic for NAND Flash and CompactFlash™
- Optional Full 32-bit External Data Bus
- Up to 26-bit Address Bus (up to 64MBytes linear per chip select)
- Up to 6 chip selects, Configurable Assignment:
  - Static Memory Controller on NCS0
  - DDR2/SDRAM Controller (SDCS) or Static Memory Controller on NCS1
  - Static Memory Controller on NCS2
  - Static Memory Controller on NCS3, Optional NAND Flash support
  - Static Memory Controller on NCS4 - NCS5, Optional CompactFlash™ support

#### 7.3.2.1 Static Memory Controller

- 8-, 16- or 32-bit Data Bus
- Multiple Access Modes supported
  - Byte Write or Byte Select Lines
  - Asynchronous read in Page Mode supported (4- up to 32-byte page size)
- Multiple device adaptability
  - Control signals programmable setup, pulse and hold time for each Memory Bank
- Multiple Wait State Management
  - Programmable Wait State Generation
  - External Wait Request
  - Programmable Data Float Time
- Slow Clock mode supported

#### 7.3.2.2 DDR2/SDR Controller

- Supports DDR2/LPDDR2, SDR-SDRAM and LPSDR
- Numerous Configurations Supported
  - 2K, 4K, 8K, 16K Row Address Memory Parts
  - SDRAM with Four Internal Banks
  - SDR-SDRAM with 16- or 32- bit Data Path
  - DDR2/LPDDR with 16- bit Data Path
  - One Chip Select for SDRAM Device (256 Mbyte Address Space)
- Programming Facilities
  - Multibank Ping-pong Access (Up to 4 Banks Opened at Same Time = Reduces Average Latency of Transactions)
  - Timing Parameters Specified by Software
  - Automatic Refresh Operation, Refresh Rate is Programmable
  - Automatic Update of DS, TCR and PASR Parameters (LPSDR)
- Energy-saving Capabilities
  - Self-refresh, Power-down and Deep Power Modes Supported

- SDRAM Power-up Initialization by Software
- CAS Latency of 2, 3 Supported
- Auto Precharge Command Not Used
- SDR-SDRAM with 16-bit Datapath and Eight Columns Not Supported
  - Clock Frequency Change in Precharge Power-down Mode Not Supported

#### 7.3.2.3 NAND Flash Error Corrected Code Controller

- Tracking the accesses to a NAND Flash device by triggering on the corresponding chip select
- Single bit error correction and 2-bit Random detection.
- Automatic Hamming Code Calculation while writing
  - ECC value available in a register
- Automatic Hamming Code Calculation while reading
  - Error Report, including error flag, correctable error flag and word address being detected erroneous
  - Support 8- or 16-bit NAND Flash devices with 512-, 1024-, 2048- or 4096-bytes pages

## 8. System Controller

The System Controller is a set of peripherals that allows handling of key elements of the system, such as power, resets, clocks, time, interrupts, watchdog, etc.

The System Controller User Interface also embeds the registers that configure the Matrix and a set of registers for the chip configuration. The chip configuration registers configure the EBI chip select assignment and voltage range for external memories.

### 8.1 System Controller Mapping

The System Controller's peripherals are all mapped within the highest 16 KBytes of address space, between addresses 0xFFFF E800 and 0xFFFF FFFF.

However, all the registers of the System Controller are mapped on the top of the address space. All the registers of the System Controller can be addressed from a single pointer by using the standard ARM instruction set, as the Load/Store instructions have an indexing mode of  $\pm 4$  KB.

[Figure 8-1 on page 30](#) shows the System Controller block diagram.

[Figure 7-1 on page 23](#) shows the mapping of the User Interfaces of the System Controller peripherals.

## 8.2 System Controller Block Diagram

Figure 8-1. SAM9G45 System Controller Block Diagram

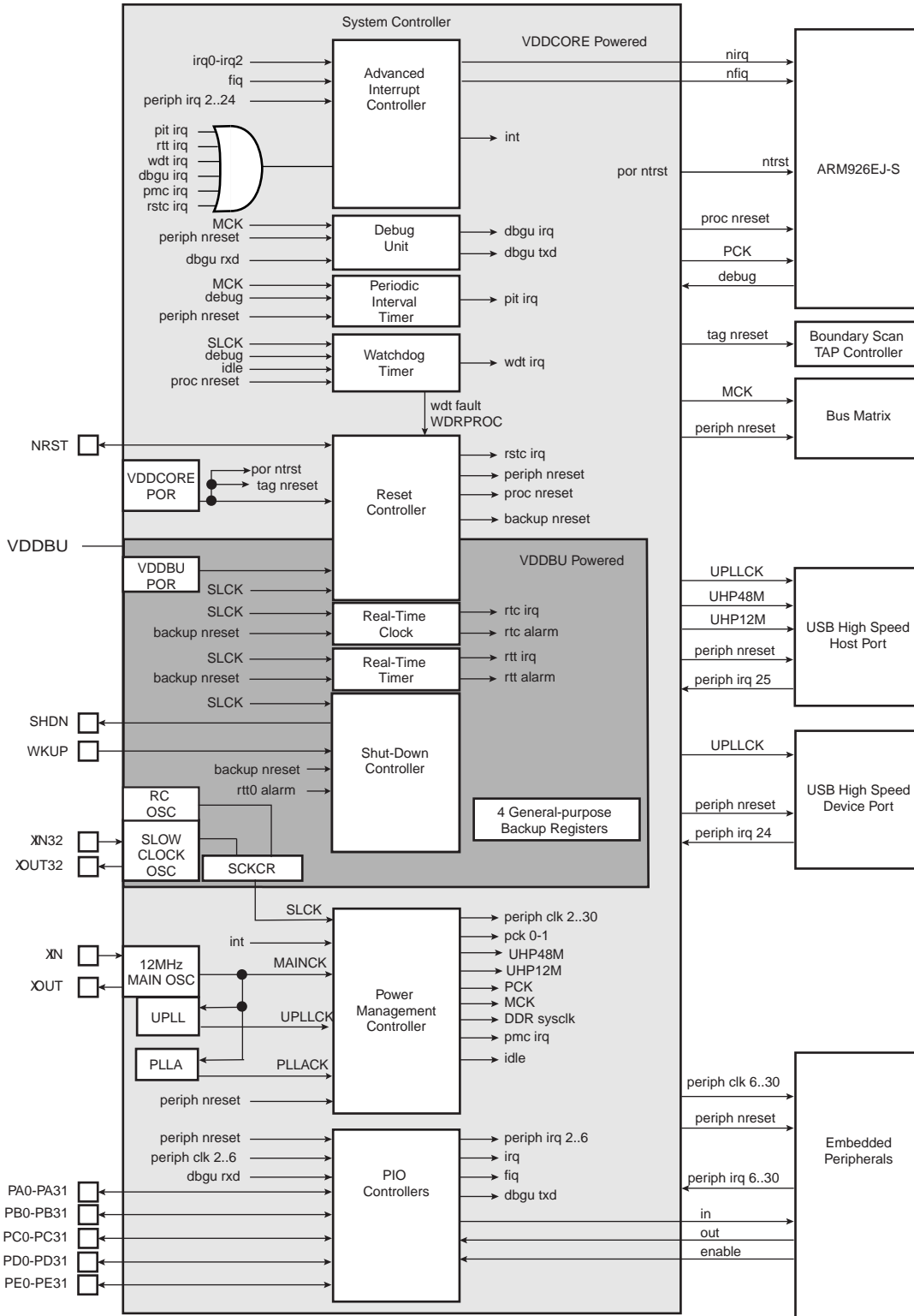

### 8.3 Reset Controller

The Reset Controller is based on two Power-on-Reset cells, one on VDDDBU and one on VDDCORE.

The Reset Controller is capable to return to the software the source of the last reset, either a general reset (VDDDBU rising), a wake-up reset (VDDCORE rising), a software reset, a user reset or a watchdog reset.

The Reset Controller controls the internal resets of the system and the NRST pin output. It is capable to shape a reset signal for the external devices, simplifying to a minimum connection of a push-button on the NRST pin to implement a manual reset.

The configuration of the Reset Controller is saved as supplied on VDDDBU.

### 8.4 Shut Down Controller

The Shut Down Controller is supplied on VDDDBU and allows a software-controllable shut down of the system through the pin SHDN. An input change of the WKUP pin or an alarm releases the SHDN pin, and thus wakes up the system power supply.

### 8.5 Clock Generator

The Clock Generator is made up of:

- One Low Power 32768 Hz Slow Clock Oscillator with bypass mode
- One Low-Power RC oscillator
- One 12 MHz Main Oscillator, which can be bypassed
- One 400 to 800 MHz programmable PLLA, capable to provide the clock MCK to the processor and to the peripherals. This PLL has an input divider to offer a wider range of output frequencies from the 12 MHz input, the only limitation being the lowest input frequency shall be higher or equal to 2 MHz.

The USB Device and Host HS Clocks are provided by a the dedicated UTMI PLL (UPLL) embedded in the UTMI macro.

Figure 8-2. Clock Generator Block Diagram

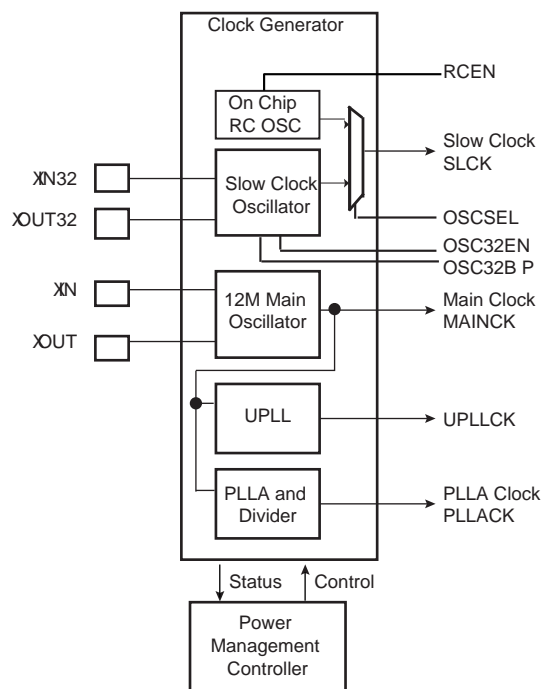

## 8.6 Slow Clock Selection

The SAM9G45 slow clock can be generated either by an external 32768Hz crystal or the on-chip RC oscillator. The 32768 Hz crystal oscillator can be bypassed, by setting the bit OSC32BYP, to accept an external slow clock on XIN32.

The internal RC oscillator and the 32768 Hz oscillator can be enabled by setting to 1 respectively RCEN bit and OSC32EN bit in the system controller user interface. OSCSEL command selects the slow clock source.

RCEN, OSC32EN, OSCSEL and OSC32BYP bits are located in the slow clock control register (SCKCR) located at address 0xFFFFFD50 in the backup part of the system controller and so are preserved while VDDBU is present.

Figure 8-3. Slow Clock

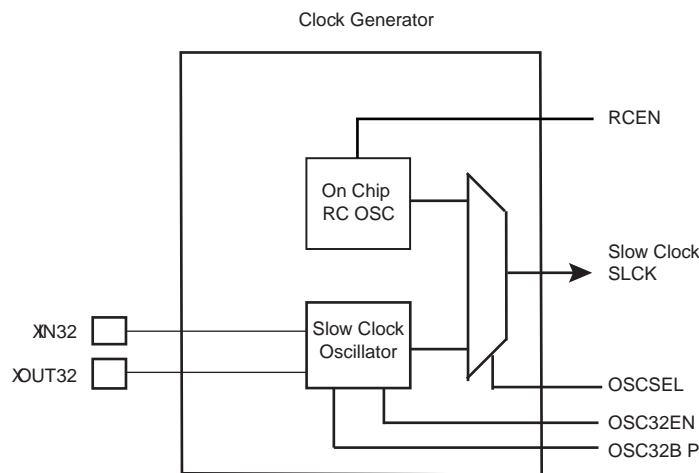

After a VDDBU power on reset, the default configuration is RCEN = 1, OSC32EN = 0 and OSCSEL = 0 allowing the system to start on the internal RC oscillator.

The programmer controls by software the slow clock switching and so must take precautions during the switching phase.

### 8.6.1 Switch from Internal RC Oscillator to the 32768 Hz Crystal

To switch from internal RC oscillator to the 32768 Hz crystal, the programmer must execute the following sequence:

- Switch the master clock to a source different from slow clock (PLLA or PLLB or Main Oscillator) through the Power Management Controller.
- Enable the 32768 Hz oscillator by setting the bit OSCEN to 1.
- Wait 32768 Hz startup time for clock stabilization (software loop).
- Switch from internal RC to 32768 Hz by setting the bit OSCSEL to 1.
- Wait 5 slow clock cycles for internal resynchronization.
- Disable the RC oscillator by setting the bit RCEN to 0.

### 8.6.2 Bypass the 32768 Hz Oscillator

The following step must be added to bypass the 32768 Hz Oscillator.

- An external clock must be connected on XIN32.
- Enable the bypass path OSC32BYP bit set to 1.
- Disable the 32768 Hz oscillator by setting the bit OSC32EN to 0.

### 8.6.3 Switch from 32768 Hz Crystal to the Internal RC Oscillator

The same procedure must be followed to switch from 32768 Hz crystal to the internal RC oscillator.

- Switch the master clock to a source different from slow clock (PLLA or PLLB or Main Oscillator).
- Enable the internal RC oscillator by setting the bit RCEN to 1.

- Wait internal RC Startup Time for clock stabilization (software loop).
- Switch from 32768 Hz oscillator to internal RC oscillator by setting the bit OSCSEL to 0.
- Wait 5 slow clock cycles for internal resynchronization.
- Disable the 32768Hz oscillator by setting the bit OSC32EN to 0.

## 8.7 Power Management Controller

The Power Management Controller provides all the clock signals to the system.

PMC input clocks:

- UPLLCK: From UTMI PLL
- PLLACK From PLLA
- SLCK: slow clock from OSC32K or internal RC OSC
- MAINCK: from 12 MHz external oscillator

PMC output clocks

- Processor Clock PCK
- Master Clock MCK, in particular to the Matrix and the memory interfaces. The divider can be 1,2,3 or 4
- DDR system clock equal to 2xMCK

Note: DDR system clock is not available when Master Clock (MCK) equals Processor Clock (PCK).

- USB Host EHCI High speed clock (UPLLCK)
- USB OHCI clocks (UHP48M and UHP12M)
- Independent peripheral clocks, typically at the frequency of MCK
- Two programmable clock outputs: PCK0 and PCK1

This allows the software control of five flexible operating modes:

- Normal Mode, processor and peripherals running at a programmable frequency
- Idle Mode, processor stopped waiting for an interrupt
- Slow Clock Mode, processor and peripherals running at low frequency
- Standby Mode, mix of Idle and Backup Mode, peripheral running at low frequency, processor stopped waiting for an interrupt
- Backup Mode, Main Power Supplies off, VDDBU powered by a battery

**Figure 8-4. SAM9G45 Power Management Controller Block Diagram**

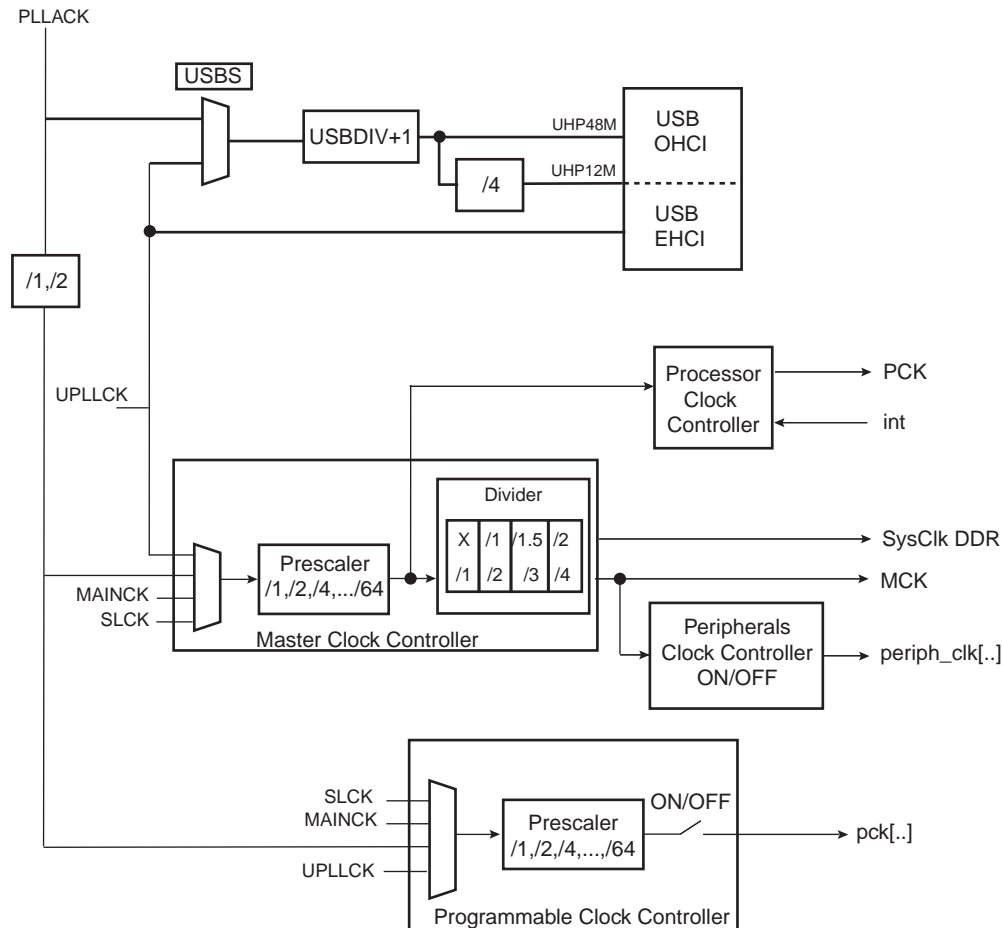

### 8.7.1 Main Application Modes

The Power Management Controller provides 3 main application modes.

#### 8.7.1.1 Normal Mode

- PLLA and UPLL are running respectively at 400 MHz and 480 MHz
- USB Device High Speed and Host EHCI High Speed operations are allowed
- Full Speed OHCI input clock is UPLLCK, USBDIV is 9 (division by 10)
- System Input clock is PLLACK, PCK is 400 MHz
- MDIV is '11', MCK is 133 MHz
- DDR2 can be used at up to 133 MHz

#### 8.7.1.2 USB HS and LP-DDR Mode

- Only UPLL is running at 480 MHz, PLLA power consumption is saved
- USB Device High Speed and Host EHCI High Speed operations are allowed
- Full Speed OHCI input clock is UPLLCK, USBDIV is 9 (division by 10)
- System Input clock is UPLLCK, Prescaler is 2, PCK is 240 MHz
- MDIV is '01', MCK is 120 MHz
- Only LP-DDR can be used at up to 120 MHz

#### 8.7.1.3 No UDP HS, UHP FS and DDR2 Mode

- Only PLLA is running at 384 MHz, UPLL power consumption is saved

- USB Device High Speed and Host EHCI High Speed operations are NOT allowed
- Full Speed OHCI input clock is PLLACK, USBDIV is 7 (division by 8)
- System Input clock is PLLACK, PCK is 384 MHz
- MDIV is '11', MCK is 128 MHz
- DDR2 can be used at up to 128 MHz

## 8.8 Periodic Interval Timer

- Includes a 20-bit Periodic Counter, with less than 1 $\mu$ s accuracy
- Includes a 12-bit Interval Overlay Counter
- Real Time OS or Linux/WinCE compliant tick generator

## 8.9 Watchdog Timer

- 16-bit key-protected only-once-Programmable Counter
- Windowed, prevents the processor to be in a dead-lock on the watchdog access

## 8.10 Real-Time Timer

- Real-Time Timer, allowing backup of time with different accuracies
  - 32-bit Free-running back-up Counter
  - Integrates a 16-bit programmable prescaler running on slow clock
  - Alarm Register capable to generate a wake-up of the system through the Shut Down Controller

## 8.11 Real Time Clock

- Low power consumption
- Full asynchronous design
- Two hundred year calendar
- Programmable Periodic Interrupt
- Alarm and update parallel load
- Control of alarm and update Time/Calendar Data In

## 8.12 General-Purpose Backup Registers

- Four 32-bit backup general-purpose registers

## 8.13 Advanced Interrupt Controller

- Controls the interrupt lines (nIRQ and nFIQ) of the ARM Processor
- Thirty-two individually maskable and vectored interrupt sources
  - Source 0 is reserved for the Fast Interrupt Input (FIQ)
  - Source 1 is reserved for system peripherals (PIT, RTT, PMC, DBGU, etc.)
  - Programmable Edge-triggered or Level-sensitive Internal Sources
  - Programmable Positive/Negative Edge-triggered or High/Low Level-sensitive
- One External Sources plus the Fast Interrupt signal
- 8-level Priority Controller
  - Drives the Normal Interrupt of the processor
  - Handles priority of the interrupt sources 1 to 31
  - Higher priority interrupts can be served during service of lower priority interrupt
- Vectoring
  - Optimizes Interrupt Service Routine Branch and Execution

- One 32-bit Vector Register per interrupt source
- Interrupt Vector Register reads the corresponding current Interrupt Vector
- Protect Mode
  - Easy debugging by preventing automatic operations when protect modes are enabled
- Fast Forcing
  - Permits redirecting any normal interrupt source on the Fast Interrupt of the processor

## 8.14 Debug Unit

- Composed of two functions
  - Two-pin UART
  - Debug Communication Channel (DCC) support
- Two-pin UART
  - Implemented features are 100% compatible with the standard Atmel USART
  - Independent receiver and transmitter with a common programmable Baud Rate Generator
  - Even, Odd, Mark or Space Parity Generation
  - Parity, Framing and Overrun Error Detection
  - Automatic Echo, Local Loopback and Remote Loopback Channel Modes
  - Support for two PDC channels with connection to receiver and transmitter
- Debug Communication Channel Support
  - Offers visibility of and interrupt trigger from COMMRX and COMMTX signals from the ARM Processor's ICE Interface

## 8.15 Chip Identification

The SAM9G45 Chip ID is defined in the Debug Unit Chip ID Register and Debug Unit Chip ID Extension Register.

- Chip ID: 0x819B05A2
- Ext ID: 0x00000004
- JTAG ID: 05B2\_703F
- ARM926 TAP ID: 0x0792603F

## 8.16 PIO Controllers

- 5 PIO Controllers, PIOA, PIOB, PIOC, PIOD and PIOE, controlling a maximum of 160 I/O Lines
- Each PIO Controller controls up to 32 programmable I/O Lines
  - PIOA has 32 I/O Lines
  - PIOB has 32 I/O Lines
  - PIOC has 32 I/O Lines
  - PIOD has 32 I/O Lines
  - PIOE has 32 I/O Lines
- Fully programmable through Set/Clear Registers
- Multiplexing of two peripheral functions per I/O Line
- For each I/O Line (whether assigned to a peripheral or used as general purpose I/O)
  - Input change interrupt
  - Glitch filter
  - Multi-drive option enables driving in open drain
  - Programmable pull up on each I/O line
  - Pin data status register, supplies visibility of the level on the pin at any time
- Synchronous output, provides Set and Clear of several I/O lines in a single write

## 9. Peripherals

### 9.1 Peripheral Mapping

As shown in [Figure 7-1](#), the Peripherals are mapped in the upper 256 Mbytes of the address space between the addresses 0xFFFF7 8000 and 0xFFFFC FFFF.

Each User Peripheral is allocated 16K bytes of address space.

### 9.2 Peripheral Identifiers

[Table 9-1](#) defines the Peripheral Identifiers of the SAM9G45. A peripheral identifier is required for the control of the peripheral interrupt with the Advanced Interrupt Controller and for the control of the peripheral clock with the Power Management Controller.

**Table 9-1. SAM9G45 Peripheral Identifiers**

Peripheral ID	Peripheral Mnemonic	Peripheral Name	External Interrupt
0	AIC	Advanced Interrupt Controller	FIQ
1	SYSC	System Controller Interrupt	
2	PIOA	Parallel I/O Controller A,	
3	PIOB	Parallel I/O Controller B	
4	PIOC	Parallel I/O Controller C	
5	PIOD/PIOE	Parallel I/O Controller D/E	
6	TRNG	True Random Number Generator	
7	US0	USART 0	
8	US1	USART 1	
9	US2	USART 2	
10	US3	USART 3	
11	MCI0	High Speed Multimedia Card Interface 0	
12	TWI0	Two-Wire Interface 0	
13	TWI1	Two-Wire Interface 1	
14	SPI0	Serial Peripheral Interface	
15	SPI1	Serial Peripheral Interface	
16	SSC0	Synchronous Serial Controller 0	
17	SSC1	Synchronous Serial Controller 1	
18	TC0..TC5	Timer Counter 0,1,2,3,4,5	
19	PWM	Pulse Width Modulation Controller	
20	TSADCC	Touch Screen ADC Controller	
21	DMA	DMA Controller	
22	UHPHS	USB Host High Speed	
23	LCDC	LCD Controller	
24	AC97C	AC97 Controller	
25	EMAC	Ethernet MAC	
26	ISI	Image Sensor Interface	
27	UDPHS	USB Device High Speed	
29	MCI1	High Speed Multimedia Card Interface 1	
30	Reserved		
31	AIC	Advanced Interrupt Controller	IRQ

## 9.3 Peripheral Interrupts and Clock Control

### 9.3.1 System Interrupt

The System Interrupt in Source 1 is the wired-OR of the interrupt signals coming from:

- the DDR2/LPDDR Controller
- the Debug Unit
- the Periodic Interval Timer
- the Real-Time Timer
- the Real-Time Clock
- the Watchdog Timer
- the Reset Controller
- the Power Management Controller

The clock of these peripherals cannot be deactivated and Peripheral ID 1 can only be used within the Advanced Interrupt Controller.

### 9.3.2 External Interrupts

All external interrupt signals, i.e., the Fast Interrupt signal FIQ or the Interrupt signal IRQ, use a dedicated Peripheral ID. However, there is no clock control associated with these peripheral IDs.

## 9.4 Peripheral Signals Multiplexing on I/O Lines

The SAM9G45 features 5 PIO controllers, PIOA, PIOB, PIOC, PIOD and PIOE, which multiplexes the I/O lines of the peripheral set.

Each PIO Controller controls up to 32 lines. Each line can be assigned to one of two peripheral functions, A or B. The multiplexing tables in the following paragraphs define how the I/O lines of the peripherals A and B are multiplexed on the PIO Controllers. The two columns “Function” and “Comments” have been inserted in this table for the user’s own comments; they may be used to track how pins are defined in an application.

Note that some peripheral function which are output only, might be duplicated within the both tables.

The column “Reset State” indicates whether the PIO Line resets in I/O mode or in peripheral mode. If I/O is mentioned, the PIO Line resets in input with the pull-up enabled, so that the device is maintained in a static state as soon as the reset is released. As a result, the bit corresponding to the PIO Line in the register PIO\_PSR (Peripheral Status Register) resets low.

If a signal name is mentioned in the “Reset State” column, the PIO Line is assigned to this function and the corresponding bit in PIO\_PSR resets high. This is the case of pins controlling memories, in particular the address lines, which require the pin to be driven as soon as the reset is released. Note that the pull-up resistor is also enabled in this case.

To amend EMC, programmable delay has been inserted on PIO lines able to run at high speed.

## 9.4.1 PIO Controller A Multiplexing

Table 9-2. Multiplexing on PIO Controller A (PIOA)

I/O Line	Peripheral A	Peripheral B	Reset State	Power Supply	Function	Comments
PA0	MCI0_CK	TCLK3	I/O	VDDIOP0		
PA1	MCI0_CDA	TIOA3	I/O	VDDIOP0		
PA2	MCI0_DA0	TIOB3	I/O	VDDIOP0		
PA3	MCI0_DA1	TCKL4	I/O	VDDIOP0		
PA4	MCI0_DA2	TIOA4	I/O	VDDIOP0		
PA5	MCI0_DA3	TIOB4	I/O	VDDIOP0		
PA6	MCI0_DA4	ETX2	I/O	VDDIOP0		
PA7	MCI0_DA5	ETX3	I/O	VDDIOP0		
PA8	MCI0_DA6	ERX2	I/O	VDDIOP0		
PA9	MCI0_DA7	ERX3	I/O	VDDIOP0		
PA10	ETX0		I/O	VDDIOP0		
PA11	ETX1		I/O	VDDIOP0		
PA12	ERX0		I/O	VDDIOP0		
PA13	ERX1		I/O	VDDIOP0		
PA14	ETXEN		I/O	VDDIOP0		
PA15	ERXDV		I/O	VDDIOP0		
PA16	ERXER		I/O	VDDIOP0		
PA17	ETXCK		I/O	VDDIOP0		
PA18	EMDC		I/O	VDDIOP0		
PA19	EMDIO		I/O	VDDIOP0		
PA20	TWD0		I/O	VDDIOP0		
PA21	TWCK0		I/O	VDDIOP0		
PA22	MCI1_CDA	SCK3	I/O	VDDIOP0		
PA23	MCI1_DA0	RTS3	I/O	VDDIOP0		
PA24	MCI1_DA1	CTS3	I/O	VDDIOP0		
PA25	MCI1_DA2	PWM3	I/O	VDDIOP0		
PA26	MCI1_DA3	TIOB2	I/O	VDDIOP0		
PA27	MCI1_DA4	ETXER	I/O	VDDIOP0		
PA28	MCI1_DA5	ERXCK	I/O	VDDIOP0		
PA29	MCI1_DA6	ECRS	I/O	VDDIOP0		
PA30	MCI1_DA7	ECOL	I/O	VDDIOP0		
PA31	MCI1_CK	PCK0	I/O	VDDIOP0		

## 9.4.2 PIO Controller B Multiplexing

Table 9-3. Multiplexing on PIO Controller B (PIOB)

I/O Line	Peripheral A	Peripheral B	Reset State	Power Supply	Function	Comments
PB0	SPI0_MISO		I/O	VDDIOP0		
PB1	SPI0_MOSI		I/O	VDDIOP0		
PB2	SPI0_SPCK		I/O	VDDIOP0		
PB3	SPI0_NPCS0		I/O	VDDIOP0		
PB4	TXD1		I/O	VDDIOP0		
PB5	RXD1		I/O	VDDIOP0		
PB6	TXD2		I/O	VDDIOP0		
PB7	RXD2		I/O	VDDIOP0		
PB8	TXD3	ISI_D8	I/O	VDDIOP2		
PB9	RXD3	ISI_D9	I/O	VDDIOP2		
PB10	TWD1	ISI_D10	I/O	VDDIOP2		
PB11	TWCK1	ISI_D11	I/O	VDDIOP2		
PB12	DRXD		I/O	VDDIOP0		
PB13	DTXD		I/O	VDDIOP0		
PB14	SPI1_MISO		I/O	VDDIOP0		
PB15	SPI1_MOSI	CTS0	I/O	VDDIOP0		
PB16	SPI1_SPCK	SCK0	I/O	VDDIOP0		
PB17	SPI1_NPCS0	RTS0	I/O	VDDIOP0		
PB18	RXD0	SPI0_NPCS1	I/O	VDDIOP0		
PB19	TXD0	SPI0_NPCS2	I/O	VDDIOP0		
PB20	ISI_D0		I/O	VDDIOP2		
PB21	ISI_D1		I/O	VDDIOP2		
PB22	ISI_D2		I/O	VDDIOP2		
PB23	ISI_D3		I/O	VDDIOP2		
PB24	ISI_D4		I/O	VDDIOP2		
PB25	ISI_D5		I/O	VDDIOP2		
PB26	ISI_D6		I/O	VDDIOP2		
PB27	ISI_D7		I/O	VDDIOP2		
PB28	ISI_PCK		I/O	VDDIOP2		
PB29	ISI_VSYNC		I/O	VDDIOP2		
PB30	ISI_HSYNC		I/O	VDDIOP2		
PB31	ISI_MCK	PCK1	I/O	VDDIOP2		

### 9.4.3 PIO Controller C Multiplexing

Table 9-4. Multiplexing on PIO Controller C (PIOC)

I/O Line	Peripheral A	Peripheral B	Reset State	Power Supply	Function	Comments
PC0	DQM2		DQM2	VDDIOM1		
PC1	DQM3		DQM3	VDDIOM1		
PC2	A19		A19	VDDIOM1		
PC3	A20		A20	VDDIOM1		
PC4	A21/NANDALE		A21	VDDIOM1		
PC5	A22/NANDCLE		A22	VDDIOM1		
PC6	A23		A23	VDDIOM1		
PC7	A24		A24	VDDIOM1		
PC8	CFCE1		I/O	VDDIOM1		
PC9	CFCE2	RTS2	I/O	VDDIOM1		
PC10	NCS4/CFCS0	TCLK2	I/O	VDDIOM1		
PC11	NCS5/CFCS1	CTS2	I/O	VDDIOM1		
PC12	A25/CFRNW		A25	VDDIOM1		
PC13	NCS2		I/O	VDDIOM1		
PC14	NCS3/NANDCS		I/O	VDDIOM1		
PC15	NWAIT		I/O	VDDIOM1		
PC16	D16		I/O	VDDIOM1		
PC17	D17		I/O	VDDIOM1		
PC18	D18		I/O	VDDIOM1		
PC19	D19		I/O	VDDIOM1		
PC20	D20		I/O	VDDIOM1		
PC21	D21		I/O	VDDIOM1		
PC22	D22		I/O	VDDIOM1		
PC23	D23		I/O	VDDIOM1		
PC24	D24		I/O	VDDIOM1		
PC25	D25		I/O	VDDIOM1		
PC26	D26		I/O	VDDIOM1		
PC27	D27		I/O	VDDIOM1		
PC28	D28		I/O	VDDIOM1		
PC29	D29		I/O	VDDIOM1		
PC30	D30		I/O	VDDIOM1		
PC31	D31		I/O	VDDIOM1		

## 9.4.4 PIO Controller D Multiplexing

Table 9-5. Multiplexing on PIO Controller D (PIOD)

I/O Line	Peripheral A	Peripheral B	Reset State	Power Supply	Function	Comments
PD0	TK0	PWM3	I/O	VDDIOP0		
PD1	TF0		I/O	VDDIOP0		
PD2	TD0		I/O	VDDIOP0		
PD3	RD0		I/O	VDDIOP0		
PD4	RK0		I/O	VDDIOP0		
PD5	RF0		I/O	VDDIOP0		
PD6	AC97RX		I/O	VDDIOP0		
PD7	AC97TX	TIOA5	I/O	VDDIOP0		
PD8	AC97FS	TIOB5	I/O	VDDIOP0		
PD9	AC97CK	TCLK5	I/O	VDDIOP0		
PD10	TD1		I/O	VDDIOP0		
PD11	RD1		I/O	VDDIOP0		
PD12	TK1	PCK0	I/O	VDDIOP0		
PD13	RK1		I/O	VDDIOP0		
PD14	TF1		I/O	VDDIOP0		
PD15	RF1		I/O	VDDIOP0		
PD16	RTS1		I/O	VDDIOP0		
PD17	CTS1		I/O	VDDIOP0		
PD18	SPI1_NPCS2	IRQ	I/O	VDDIOP0		
PD19	SPI1_NPCS3	FIQ	I/O	VDDIOP0		
PD20	TIOA0		I/O	VDDANA		TSAD0
PD21	TIOA1		I/O	VDDANA		TSAD1
PD22	TIOA2		I/O	VDDANA		TSAD2
PD23	TCLK0		I/O	VDDANA		TSAD3
PD24	SPI0_NPCS1	PWM0	I/O	VDDANA		GPAD4
PD25	SPI0_NPCS2	PWM1	I/O	VDDANA		GPAD5
PD26	PCK0	PWM2	I/O	VDDANA		GPAD6
PD27	PCK1	SPI0_NPCS3	I/O	VDDANA		GPAD7
PD28	TSADTRG	SPI1_NPCS1	I/O	VDDIOP0		
PD29	TCLK1	SCK1	I/O	VDDIOP0		
PD30	TIOB0	SCK2	I/O	VDDIOP0		
PD31	TIOB1	PWM1	I/O	VDDIOP0		

## 9.4.5 PIO Controller E Multiplexing

Table 9-6. Multiplexing on PIO Controller E (PIOE)

I/O Line	Peripheral A	Peripheral B	Reset State	Power Supply	Function	Comments
PE0	LCDPWR	PCK0	I/O	VDDIOP1		
PE1	LCDMOD		I/O	VDDIOP1		
PE2	LCDDC		I/O	VDDIOP1		
PE3	LCDVSYNC		I/O	VDDIOP1		
PE4	LCDHSYNC		I/O	VDDIOP1		
PE5	LCDDOTCK		I/O	VDDIOP1		
PE6	LCDDEN		I/O	VDDIOP1		
PE7	LCDD0	LCDD2	I/O	VDDIOP1		
PE8	LCDD1	LCDD3	I/O	VDDIOP1		
PE9	LCDD2	LCDD4	I/O	VDDIOP1		
PE10	LCDD3	LCDD5	I/O	VDDIOP1		
PE11	LCDD4	LCDD6	I/O	VDDIOP1		
PE12	LCDD5	LCDD7	I/O	VDDIOP1		
PE13	LCDD6	LCDD10	I/O	VDDIOP1		
PE14	LCDD7	LCDD11	I/O	VDDIOP1		
PE15	LCDD8	LCDD12	I/O	VDDIOP1		
PE16	LCDD9	LCDD13	I/O	VDDIOP1		
PE17	LCDD10	LCDD14	I/O	VDDIOP1		
PE18	LCDD11	LCDD15	I/O	VDDIOP1		
PE19	LCDD12	LCDD18	I/O	VDDIOP1		
PE20	LCDD13	LCDD19	I/O	VDDIOP1		
PE21	LCDD14	LCDD20	I/O	VDDIOP1		
PE22	LCDD15	LCDD21	I/O	VDDIOP1		
PE23	LCDD16	LCDD22	I/O	VDDIOP1		
PE24	LCDD17	LCDD23	I/O	VDDIOP1		
PE25	LCDD18		I/O	VDDIOP1		
PE26	LCDD19		I/O	VDDIOP1		
PE27	LCDD20		I/O	VDDIOP1		
PE28	LCDD21		I/O	VDDIOP1		
PE29	LCDD22		I/O	VDDIOP1		
PE30	LCDD23		I/O	VDDIOP1		
PE31	PWM2	PCK1	I/O	VDDIOP1		

## 10. Embedded Peripherals

### 10.1 Serial Peripheral Interface (SPI)

- Supports communication with serial external devices
  - Four chip selects with external decoder support allow communication with up to 15 peripherals
  - Serial memories, such as DataFlash and 3-wire EEPROMs
  - Serial peripherals, such as ADCs, DACs, LCD Controllers, CAN Controllers and Sensors
  - External co-processors
- Master or slave serial peripheral bus interface
  - 8- to 16-bit programmable data length per chip select
  - Programmable phase and polarity per chip select
  - Programmable transfer delays between consecutive transfers and between clock and data per chip select
  - Programmable delay between consecutive transfers
  - Selectable mode fault detection
- Very fast transfers supported
  - Transfers with baud rates up to MCK
  - The chip select line may be left active to speed up transfers on the same device

### 10.2 Two Wire Interface (TWI)

- Compatibility with standard two-wire serial memory
- One, two or three bytes for slave address
- Sequential read/write operations
- Supports either master or slave modes
- Compatible with Standard Two-wire Serial Memories
- Master, Multi-master and Slave Mode Operation
- Bit Rate: Up to 400 Kbits
- General Call Supported in Slave mode
- Connection to Peripheral DMA Controller (PDC) Channel Capabilities Optimizes Data Transfers in Master Mode Only
  - One Channel for the Receiver, One Channel for the Transmitter
  - Next Buffer Support

### 10.3 Universal Synchronous Asynchronous Receiver Transmitter (USART)

- Programmable Baud Rate Generator
- 5- to 9-bit full-duplex synchronous or asynchronous serial communications
  - 1, 1.5 or 2 stop bits in Asynchronous Mode or 1 or 2 stop bits in Synchronous Mode
  - Parity generation and error detection
  - Framing error detection, overrun error detection
  - MSB- or LSB-first
  - Optional break generation and detection
  - By 8 or by-16 over-sampling receiver frequency
  - Hardware handshaking RTS-CTS
  - Receiver time-out and transmitter timeguard
  - Optional Multi-drop Mode with address generation and detection
  - Optional Manchester Encoding

- RS485 with driver control signal
- ISO7816, T = 0 or T = 1 Protocols for interfacing with smart cards
  - NACK handling, error counter with repetition and iteration limit
- IrDA modulation and demodulation
  - Communication at up to 115.2 Kbps
- Test Modes
  - Remote Loopback, Local Loopback, Automatic Echo

#### 10.4 Serial Synchronous Controller (SSC)

- Provides serial synchronous communication links used in audio and telecom applications (with CODECs in Master or Slave Modes, I<sup>2</sup>S, TDM Buses, Magnetic Card Reader,...)
- Contains an independent receiver and transmitter and a common clock divider
- Offers a configurable frame sync and data length
- Receiver and transmitter can be programmed to start automatically or on detection of different event on the frame sync signal
- Receiver and transmitter include a data signal, a clock signal and a frame synchronization signal

#### 10.5 AC97 Controller

- Compatible with AC97 Component Specification V2.2
- Capable to Interface with a Single Analog Front end
- Three independent RX Channels and three independent TX Channels
  - One RX and one TX channel dedicated to the AC97 Analog Front end control
  - One RX and one TX channel for data transfers, associated with a PDC
  - One RX and one TX channel for data transfers with no PDC
- Time Slot Assigner allowing to assign up to 12 time slots to a channel
- Channels support mono or stereo up to 20 bit sample length
  - Variable sampling rate AC97 Codec Interface (48KHz and below)

#### 10.6 Timer Counter (TC)

- Three 16-bit Timer Counter Channels
- Wide range of functions including:
  - Frequency Measurement
  - Event Counting
  - Interval Measurement
  - Pulse Generation
  - Delay Timing
  - Pulse Width Modulation
  - Up/down Capabilities
- Each channel is user-configurable and contains:
  - Three external clock inputs
  - Five internal clock inputs
  - Two multi-purpose input/output signals
- Two global registers that act on all three TC Channels

#### 10.7 Pulse Width Modulation Controller (PWM)

- Four channels, one 16-bit counter per channel

- Common clock generator, providing Thirteen Different Clocks
  - A Modulo n counter providing eleven clocks
  - Two independent Linear Dividers working on modulo n counter outputs
- Independent channel programming
  - Independent Enable Disable Commands
  - Independent Clock Selection
  - Independent Period and Duty Cycle, with Double Buffering
  - Programmable selection of the output waveform polarity
  - Programmable center or left aligned output waveform

## 10.8 High Speed Multimedia Card Interface (MCI)

- Compatibility with MultiMedia Card Specification Version 4.3
- Compatibility with SD Memory Card Specification Version 2.0
- Compatibility with SDIO Specification Version V2.0.
- Compatibility with Memory Stick PRO
- Compatibility with CE ATA

## 10.9 USB High Speed Host Port (UHPHS)

- Compliant with Enhanced HCI Rev 1.0 Specification
  - Compliant with USB V2.0 High-speed and Full-speed Specification
  - Supports Both High-speed 480Mbps and Full-speed 12 Mbps USB devices
- Compliant with Open HCI Rev 1.0 Specification
  - Compliant with USB V2.0 Full-speed and Low-speed Specification
  - Supports Both Low-speed 1.5 Mbps and Full-speed 12 Mbps USB devices
- Root Hub Integrated with 2 Downstream USB Ports
- Shared Embedded USB Transceivers

## 10.10 USB High Speed Device Port (UDPHS)

- USB V2.0 high-speed compliant, 480 Mbits per second
- Embedded USB V2.0 UTMI+ high-speed transceiver shared with UHP HS.
- Embedded 4-KByte dual-port RAM for endpoints
- Embedded 6 channels DMA controller
- Suspend/Resume logic
- Up to 2 or 3 banks for isochronous and bulk endpoints
- Seven endpoints:
  - Endpoint 0: 64 bytes, 1 bank mode
  - Endpoint 1 & 2: 1024 bytes, 2 banks mode, High Bandwidth, DMA
  - Endpoint 3 & 4: 1024 bytes, 3 banks mode, DMA
  - Endpoint 5 & 6: 1024 bytes, 3 banks mode, High Bandwidth, DMA

## 10.11 LCD Controller (LDC)

- Single and Dual scan color and monochrome passive STN LCD panels supported
- Single scan active TFT LCD panels supported.
- 4-bit single scan, 8-bit single or dual scan, 16-bit dual scan STN interfaces supported
- Up to 24-bit single scan TFT interfaces supported
- Up to 16 gray levels for mono STN and up to 4096 colors for color STN displays

- 1, 2 bits per pixel (palletized), 4 bits per pixel (non-palletized) for mono STN
- 1, 2, 4, 8 bits per pixel (palletized), 16 bits per pixel (non-palletized) for color STN
- 1, 2, 4, 8 bits per pixel (palletized), 16, 24 bits per pixel (non-palletized) for TFT
- Single clock domain architecture
- Resolution supported up to 2048 x 2048

## 10.12 Touch Screen Analog-to-Digital Converter (TSADC)

- 8-channel ADC
- Support 4-wire resistive Touch Screen
- 10-bit 384 Ksamples/sec. Successive Approximation Register ADC
- -3/+3 LSB Integral Non Linearity, -2/+2 LSB Differential Non Linearity
- Integrated 8-to-1 multiplexer, offering eight independent 3.3V analog inputs
- External voltage reference for better accuracy on low voltage inputs
- Individual enable and disable of each channel
- Multiple trigger sources
  - Hardware or software trigger
  - External trigger pin
- Sleep Mode and conversion sequencer
  - Automatic wakeup on trigger and back to sleep mode after conversions of all enabled channels

## 10.13 Ethernet 10/100 MAC (EMAC)

- Compatibility with IEEE Standard 802.3
- 10 and 100 MBits per second data throughput capability
- Full- and half-duplex operations
- MII or RMII interface to the physical layer
- Register Interface to address, data, status and control registers
- DMA Interface, operating as a master on the Memory Controller
- Interrupt generation to signal receive and transmit completion
- 128-byte transmit and 128-byte receive FIFOs
- Automatic pad and CRC generation on transmitted frames
- Address checking logic to recognize four 48-bit addresses
- Supports promiscuous mode where all valid frames are copied to memory
- Supports physical layer management through MDIO interface
- Supports Wake On Lan. The receiver supports Wake on LAN by detecting the following events on incoming receive frames:
  - Magic packet
  - ARP request to the device IP address
  - Specific address 1 filter match
  - Multicast hash filter match

## 10.14 Image Sensor Interface (ISI)

- ITU-R BT. 601/656 8-bit mode external interface support
- Support for ITU-R BT.656-4 SAV and EAV synchronization
- Vertical and horizontal resolutions up to 2048 x 2048
- Preview Path up to 640\*480
- Support for packed data formatting for YCbCr 4:2:2 formats

- Preview scaler to generate smaller size image

## 10.15 8-channel DMA (DMA)

- Acting as two Matrix Masters
- Embeds 8 unidirectional channels with programmable priority
- Address Generation
  - Source/Destination address programming
  - Address increment, decrement or no change
  - DMA chaining support for multiple non-contiguous data blocks through use of linked lists
  - Scatter support for placing fields into a system memory area from a contiguous transfer. Writing a stream of data into non-contiguous fields in system memory
  - Gather support for extracting fields from a system memory area into a contiguous transfer
  - User enabled auto-reloading of source, destination and control registers from initially programmed values at the end of a block transfer
  - Auto-loading of source, destination and control registers from system memory at end of block transfer in block chaining mode
  - Unaligned system address to data transfer width supported in hardware
- Channel Buffering
  - 16-word FIFO
  - Automatic packing/unpacking of data to fit FIFO width
- Channel Control
  - Programmable multiple transaction size for each channel
  - Support for cleanly disabling a channel without data loss
  - Suspend DMA operation
  - Programmable DMA lock transfer support
- Transfer Initiation
  - Support for Software handshaking interface. Memory mapped registers can be used to control the flow of a DMA transfer in place of a hardware handshaking interface
- Interrupt
  - Programmable Interrupt generation on DMA Transfer completion Block Transfer completion, Single/Multiple transaction completion or Error condition

## 10.16 True Random Number Generator (TRNG)

- Passed NIST Special Publication 800-22 Tests Suite
- Passed Diehard Random Tests Suite
- Provides a 32-bit Random Number Every 84 Clock Cycles
- For 133 MHz Clock Frequency, Throughput Close to 50 Mbits/s



## 12. SAM9G45 Ordering Information

Table 12-1. AT91SAM9G45 Ordering Information

Ordering Code	MRL	Package	Package Type	Temperature Operating Range
AT91SAM9G45C-CU	C	TFBGA324	Green	Industrial -40°C to 85°C
AT91SAM9G45B-CU	B	TFBGA324	Green	Industrial -40°C to 85°C
AT91SAM9G45-CU	A	TFBGA324	Green	Industrial -40°C to 85°C

## Revision History

In the table that follows, the initials “rfo” indicate changes requested by product experts, or made during proof reading as part of the approval process.

Doc. Rev	Comments	Change Request Ref.
6438AS	First issue	
6438BS	<a href="#">Section 3. “Signal Description”</a> , <a href="#">Table 3-1</a> in “Reset/Test” description, NRST pin updated with note concerning NRST configuration.	6600
	<a href="#">Section 4. “Package and Pinout”</a> , <a href="#">Table 4-1</a> , updated.	6669
6438CS	Introduction: “Features” part was edited.	6715
	LFBGA replaced by TFBGA in “Features” part and <a href="#">Section 4.1 “Mechanical Overview of the 324-ball TFBGA Package”</a>	RFO
	<a href="#">Section 3. “Signal Description”</a> , <a href="#">Table 3-1</a> , <a href="#">Touch Screen Analog-to-Digital Converter on page 9</a> part was edited.	6647
	VDDCORE removed from “Ground pins GND are common to...” sentence in <a href="#">Section 5.1 “Power Supplies”</a>	RFO
	Figure 6.3 was removed. 0x00500000 changed into 0x00400000 in <a href="#">Section 7.2.3 “Internal ROM”</a> .	6715
6438DS	“Two Three-channel 16-bit Timer/Counters” peripheral feature changed into “ <a href="#">Two Three-channel 16-bit Timer/Counters</a> ” .	6828
	ECC row added to <a href="#">Figure 7-1 “SAM9G45 Memory Mapping”</a>	6842
	<a href="#">Section 6.2 “Bus Matrix”</a> , <a href="#">Figure 6-1 “DDR Multi-port”</a> , and text above and below added. 1 row and 1 column added to <a href="#">Table 6-3</a> and <a href="#">Table 6-4</a> .	6797
	Typos corrected in <a href="#">Table 6-6</a> , <a href="#">Table 6-7</a> , <a href="#">Table 9-1</a> and <a href="#">Figure 2-1</a> : RNG --> TRNG, PWMC --> PWM, AC97 --> AC97C, TSDAC --> TSADCC.	RFO
6438ES	<a href="#">Section 7.3 “External Memories”</a> reorganized.	RFO
	New <a href="#">Figure 11-1 “324-ball TFBGA Package Drawing”</a> .	6954
	‘11-layer’ --> ‘12-layer’ in <a href="#">Section 6.2 “Bus Matrix”</a> .	7171
	<a href="#">Section 10.16 “True Random Number Generator (TRNG)”</a> added.	7172
6438FS	1st Page/headers & footers: (text where found) Product Line/Product naming convention changed - <b>AT91SAM ARM-based MPU / SAM9G45</b>	Marcom
	<a href="#">Section 5.1 “Power Supplies”</a> , replaced ground pin names by GNDIOM, GNDCORE, GNDANA, GNDIOP, GNDBU, GNDOSC, GNDUTMI.	7322
	Reorganized text describing GND association to power supply pins.	rfo
	<a href="#">Section 1. “Description”</a> , updated 2nd paragraph, 1st sentence. “...SAM9G45 supports DDR2...”	rfo

Doc. Rev	Comments	Change Request Ref.
6438GS	Section 12. "SAM9G45 Ordering Information", fixed error in ordering information table.	7953
6438HS	Section 12. "SAM9G45 Ordering Information", a second ordering code added: AT91SAM9G45B-CU. An MRL column added too.	7979
6438IS	Section 12. "SAM9G45 Ordering Information", added AT91SAM9G45C-CU and MLR C to Table 12-1, "AT91SAM9G45 Ordering Information"	8551
	Section 1. "Features", added Write Protected Registers to "Peripherals" .	8213



Enabling Unlimited Possibilities®

**Atmel Corporation**

1600 Technology Drive  
San Jose, CA 95110  
USA

**Tel:** (+1) (408) 441-0311

**Fax:** (+1) (408) 487-2600

[www.atmel.com](http://www.atmel.com)

**Atmel Asia Limited**

Unit 01-5 & 16, 19F  
BEA Tower, Millennium City 5  
418 Kwun Tong Road  
Kwun Tong, Kowloon

HONG KONG

**Tel:** (+852) 2245-6100

**Fax:** (+852) 2722-1369

**Atmel Munich GmbH**

Business Campus  
Parking 4  
D-85748 Garching b. Munich  
GERMANY

**Tel:** (+49) 89-31970-0

**Fax:** (+49) 89-3194621

**Atmel Japan G.K.**

16F Shin-Osaki Kangyo Bldg  
1-6-4 Osaki, Shinagawa-ku  
Tokyo 141-0032  
JAPAN

**Tel:** (+81) (3) 6417-0300

**Fax:** (+81) (3) 6417-0370

© 2013 Atmel Corporation. All rights reserved. / Rev.: 6438IS-ATARM-12-Feb-13



Atmel®, Atmel logo and combinations thereof, SAM-BA® and others are registered trademarks or trademarks of Atmel Corporation or its subsidiaries. ARM®, the ARMPowered® logo, Thumb® and others are the registered trademarks or trademarks of ARM Ltd. Windows® and others are registered trademarks or trademarks of Microsoft Corporation in the US and/or other countries. Other terms and product names may be the trademarks of others.

Disclaimer: The information in this document is provided in connection with Atmel products. No license, express or implied, by estoppel or otherwise, to any intellectual property right is granted by this document or in connection with the sale of Atmel products. EXCEPT AS SET FORTH IN THE ATMEL TERMS AND CONDITIONS OF SALES LOCATED ON THE ATMEL WEBSITE, ATMEL ASSUMES NO LIABILITY WHATSOEVER AND DISCLAIMS ANY EXPRESS, IMPLIED OR STATUTORY WARRANTY RELATING TO ITS PRODUCTS INCLUDING, BUT NOT LIMITED TO, THE IMPLIED WARRANTY OF MERCHANTABILITY, FITNESS FOR A PARTICULAR PURPOSE, OR NON-INFRINGEMENT. IN NO EVENT SHALL ATMEL BE LIABLE FOR ANY DIRECT, INDIRECT, CONSEQUENTIAL, PUNITIVE, SPECIAL OR INCIDENTAL DAMAGES (INCLUDING, WITHOUT LIMITATION, DAMAGES FOR LOSS AND PROFITS, BUSINESS INTERRUPTION, OR LOSS OF INFORMATION) ARISING OUT OF THE USE OR INABILITY TO USE THIS DOCUMENT, EVEN IF ATMEL HAS BEEN ADVISED OF THE POSSIBILITY OF SUCH DAMAGES. Atmel makes no representations or warranties with respect to the accuracy or completeness of the contents of this document and reserves the right to make changes to specifications and products descriptions at any time without notice. Atmel does not make any commitment to update the information contained herein. Unless specifically provided otherwise, Atmel products are not suitable for, and shall not be used in, automotive applications. Atmel products are not intended, authorized, or warranted for use as components in applications intended to support or sustain life.

## Looking for pricing, stock, or lifecycle information?

Click below to explore more details on WIN SOURCE:

 [View AT91SAM9G45C-CU on WIN SOURCE](#)

 [Atmel Information](#)

## Optimize Your Supply Chain with WIN SOURCE Solutions

-  Global Sourcing Solution
-  Obsolete Management
-  Cost Control Management
-  Shortage Management
-  Alternative Solution
-  Excess Inventory Management