

Features

- Incorporates the ARM926EJ-S™ ARM® Thumb® Processor
 - DSP Instruction Extensions
 - ARM Jazelle® Technology for Java® Acceleration
 - 16 Kbyte Data Cache, 16 Kbyte Instruction Cache, Write Buffer
 - 293 MIPS at 266 MHz
 - Memory Management Unit
 - EmbeddedICE™, Debug Communication Channel Support
- Additional Embedded Memories
 - 32 Kbytes of Internal ROM, Single-cycle Access at Maximum Bus Speed
 - 16 Kbytes of Internal SRAM, Single-cycle Access at Bus Speed
- External Bus Interface (EBI)
 - Supports SDRAM, Static Memory, NAND Flash and CompactFlash®
- LCD Controller
 - Supports Passive or Active Displays
 - Up to 16-bits per Pixel in STN Color Mode
 - Up to 16M Colors in TFT Mode (24-bit per Pixel), Resolution up to 1280 x 860
- USB
 - USB 2.0 Full Speed (12 Mbits per second) Host Double Port
 - OHCI Compliant
 - Dual On-chip Transceivers
 - Integrated FIFOs and Dedicated DMA Channels
 - USB 2.0 Full Speed (12 Mbits per second) Device Port
 - On-chip Transceiver, 2 Kbyte Configurable Integrated FIFOs
- Bus Matrix
 - Handles Five Masters and Five Slaves
 - Boot Mode Select Option
 - Remap Command
- Fully Featured System Controller (SYSC) for Efficient System Management, including
 - Reset Controller, Shutdown Controller, Four 32-bit Battery Backup Registers for a Total of 16 Bytes
 - Clock Generator and Power Management Controller
 - Advanced Interrupt Controller and Debug Unit
 - Periodic Interval Timer, Watchdog Timer and Real-time Timer
 - Three 32-bit PIO Controllers
- Reset Controller (RSTC)
 - Based on Power-on Reset Cells, Reset Source Identification and Reset Output Control
- Shutdown Controller (SHDWC)
 - Programmable Shutdown Pin Control and Wake-up Circuitry
- Clock Generator (CKGR)
 - 32,768 Hz Low-power Oscillator on Battery Backup Power Supply, Providing a Permanent Slow Clock
 - 3 to 20 MHz On-chip Oscillator and two PLLs
- Power Management Controller (PMC)
 - Very Slow Clock Operating Mode, Software Programmable Power Optimization Capabilities
 - Four Programmable External Clock Signals



Product Description

AT91SAM9G10

Summary

NOTE: This is a summary document. The complete document is available on the Atmel website at www.atmel.com.

6462AS-ATARM-03-Jun-09





- **Advanced Interrupt Controller (AIC)**
 - Individually Maskable, Eight-level Priority, Vectored Interrupt Sources
 - Three External Interrupt Sources and One Fast Interrupt Source, Spurious Interrupt Protected
- **Debug Unit (DBGU)**
 - 2-wire USART and support for Debug Communication Channel, Programmable ICE Access Prevention
 - Mode for General Purpose Two-wire UART Serial Communication
- **Periodic Interval Timer (PIT)**
 - 20-bit Interval Timer plus 12-bit Interval Counter
- **Watchdog Timer (WDT)**
 - Key Protected, Programmable Only Once, Windowed 12-bit Counter, Running at Slow Clock
- **Real-Time Timer (RTT)**
 - 32-bit Free-running Backup Counter Running at Slow Clock
- **Three 32-bit Parallel Input/Output Controllers (PIO) PIOA, PIOB and PIOC**
 - 96 Programmable I/O Lines Multiplexed with up to Two Peripheral I/Os
 - Input Change Interrupt Capability on Each I/O Line
 - Individually Programmable Open-drain, Pull-up Resistor and Synchronous Output
 - Schmitt Trigger on All Inputs
- **Nineteen Peripheral DMA (PDC) Channels**
- **Multimedia Card Interface (MCI)**
 - SDCard/SDIO and MultiMediaCard™ Compliant
 - Automatic Protocol Control and Fast Automatic Data Transfers with PDC, MMC and SDCard Compliant
- **Three Synchronous Serial Controllers (SSC)**
 - Independent Clock and Frame Sync Signals for Each Receiver and Transmitter
 - I²S Analog Interface Support, Time Division Multiplex Support
 - High-speed Continuous Data Stream Capabilities with 32-bit Data Transfer
- **Three Universal Synchronous/Asynchronous Receiver Transmitters (USART)**
 - Individual Baud Rate Generator, IrDA® Infrared Modulation/Demodulation
 - Support for ISO7816 T0/T1 Smart Card, Hardware and Software Handshaking, RS485 Support
- **Two Master/Slave Serial Peripheral Interface (SPI)**
 - 8- to 16-bit Programmable Data Length, Four External Peripheral Chip Selects
- **One Three-channel 16-bit Timer/Counters (TC)**
 - Three External Clock Inputs, Two multi-purpose I/O Pins per Channel
 - Double PWM Generation, Capture/Waveform Mode, Up/Down Capability
- **Two-wire Interface (TWI)**
 - Master Mode Support, All Two-wire Atmel EEPROMs Supported
 - Compatibility with Standard Two-wire Serial Memories
 - One, Two or Three Bytes for Slave Address
 - Sequential Read/Write Operations
 - Master, Multi-master and Slave Mode Operation
 - Bit rate: up to 400 Kbits
 - GEneral Call Supported in Slave Mode
- **IEEE® 1149.1 JTAG Boundary Scan on All Digital Pins**
- **Required Power Supplies:**
 - 1.08V to 1.32V for VDDCORE and VDDBU
 - 3.0V to 3.6V for VDDOSC and for VDDPLL
 - 2.7V to 3.6V for VDDIOP (Peripheral I/Os)
 - 1.65V to 3.6V for VDDIOM (Memory I/Os)
- **Available in a 217-ball LFBGA RoHS-compliant Package**

1. Description

The AT91SAM9G10 is a complete system-on-chip built around the ARM926EJ-S ARM Thumb processor with an extended DSP instruction set and Jazelle Java accelerator. It achieves 293 MIPS at 266 MHz.

The AT91SAM9G10 is an optimized host processor for applications with an LCD display. Its integrated LCD controller supports BW and up to 16M color, active and passive LCD displays. The External Bus Interface incorporates controllers for synchronous DRAM (SDRAM) and Static memories and features specific interface circuitry for CompactFlash and NAND Flash.

The AT91SAM9G10 integrates a ROM-based Boot Loader supporting code shadowing from, for example, external DataFlash[®] into external SDRAM. The software controlled Power Management Controller (PMC) keeps system power consumption to a minimum by selectively enabling/disabling the processor and various peripherals and adjustment of the operating frequency.

The AT91SAM9G10 also benefits from the integration of a wide range of debug features including JTAG-ICE, a dedicated UART debug channel (DBGU). This enables the development and debug of all applications, especially those with real-time constraints.

2. Block Diagram

Figure 2-1. AT91SAM9G10 Block Diagram

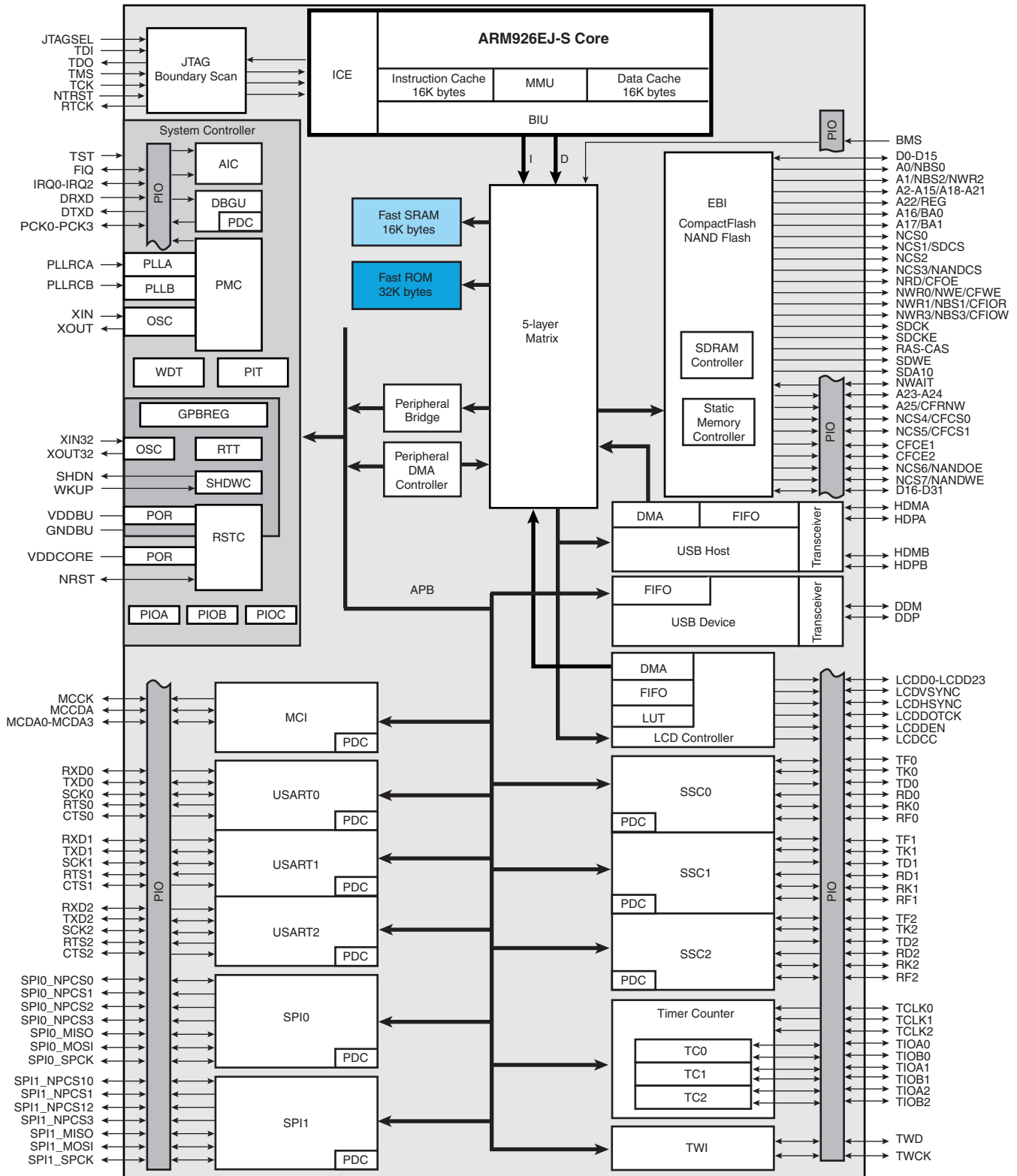

3. Signal Description

Table 3-1. Signal Description by Peripheral

Signal Name	Function	Type	Active Level	Comments
Power				
VDDIOM	EBI I/O Lines Power Supply	Power		1.65 V to 1.95V and 3.0V to 3.6V
VDDIOP	Peripherals I/O Lines Power Supply	Power		3.0V to 3.6V
VDDBU	Backup I/O Lines Power Supply	Power		1.08V to 1.32V
VDDPLL	PLL Power Supply	Power		3.0V to 3.6V
VDDOSC	Oscillator Power Supply	Power		3.0V to 3.6V
VDDCORE	Core Chip Power Supply	Power		1.08V to 1.32V
GND	Ground	Ground		
GNDPLL	PLL Ground	Ground		
GNDOSC	Oscillator Ground	Ground		
GNDBU	Backup Ground	Ground		
Clocks, Oscillators and PLLs				
XIN	Main Oscillator Input	Input		
XOUT	Main Oscillator Output	Output		
XIN32	Slow Clock Oscillator Input	Input		
XOUT32	Slow Clock Oscillator Output	Output		
PLLRC A	PLL Filter	Input		
PLLRC B	PLL Filter	Input		
PCK0 - PCK3	Programmable Clock Output	Output		
Shutdown, Wakeup Logic				
SHDN	Shutdown Control	Output		Do not tie over VDDBU.
WKUP	Wake-Up Input	Input		Accepts between 0V and VDDBU.
ICE and JTAG				
TCK	Test Clock	Input		No pull-up resistor.
RTCK	Returned Test Clock	Output		No pull-up resistor.
TDI	Test Data In	Input		No pull-up resistor.
TDO	Test Data Out	Output		
TMS	Test Mode Select	Input		No pull-up resistor.
NTRST	Test Reset Signal	Input	Low	Pull-up resistor.
JTAGSEL	JTAG Selection	Input		Pull-down resistor. Accepts between 0V and VDDBU.
Reset/Test				
NRST	Microcontroller Reset	I/O	Low	Pull-up resistor
TST	Test Mode Select	Input		Pull-down resistor.
BMS	Boot Mode Select	Input		
Debug Unit				
DRXD	Debug Receive Data	Input		
DTXD	Debug Transmit Data	Output		

Table 3-1. Signal Description by Peripheral (Continued)

Signal Name	Function	Type	Active Level	Comments
AIC				
IRQ0 - IRQ2	External Interrupt Inputs	Input		
FIQ	Fast Interrupt Input	Input		
PIO				
PA0 - PA31	Parallel IO Controller A	I/O		Pulled-up input at reset
PB0 - PB31	Parallel IO Controller B	I/O		Pulled-up input at reset
PC0 - PC31	Parallel IO Controller C	I/O		Pulled-up input at reset
EBI				
D0 - D31	Data Bus	I/O		Pulled-up input at reset
A0 - A25	Address Bus	Output		0 at reset
NWAIT	External Wait Signal	Input	Low	
SMC				
NCS0 - NCS7	Chip Select Lines	Output	Low	
NWR0 - NWR3	Write Signal	Output	Low	
NRD	Read Signal	Output	Low	
NWE	Write Enable	Output	Low	
NBS0 - NBS3	Byte Mask Signal	Output	Low	
CompactFlash Support				
CFCE1 - CFCE2	CompactFlash Chip Enable	Output	Low	
CFOE	CompactFlash Output Enable	Output	Low	
CFWE	CompactFlash Write Enable	Output	Low	
CFIOR	CompactFlash IO Read	Output	Low	
CFIOW	CompactFlash IO Write	Output	Low	
CFRNW	CompactFlash Read Not Write	Output		
CFCS0 - CFCS1	CompactFlash Chip Select Lines	Output	Low	
NAND Flash Support				
NANDOE	NAND Flash Output Enable	Output	Low	
NANDWE	NAND Flash Write Enable	Output	Low	
NANDCS	NAND Flash Chip Select	Output	Low	
SDRAM Controller				
SDCK	SDRAM Clock	Output		
SDCKE	SDRAM Clock Enable	Output	High	
SDCS	SDRAM Controller Chip Select	Output	Low	
BA0 - BA1	Bank Select	Output		
SDWE	SDRAM Write Enable	Output	Low	
RAS - CAS	Row and Column Signal	Output	Low	
SDA10	SDRAM Address 10 Line	Output		
Multimedia Card Interface				
MCCK	Multimedia Card Clock	Output		
MCCDA	Multimedia Card A Command	I/O		
MCDA0 - MCDA3	Multimedia Card A Data	I/O		

Table 3-1. Signal Description by Peripheral (Continued)

Signal Name	Function	Type	Active Level	Comments
USART				
SCK0 - SCK2	Serial Clock	I/O		
TXD0 - TXD2	Transmit Data	Output		
RXD0 - RXD2	Receive Data	Input		
RTS0 - RTS2	Request To Send	Output		
CTS0 - CTS2	Clear To Send	Input		
Synchronous Serial Controller				
TD0 - TD2	Transmit Data	Output		
RD0 - RD2	Receive Data	Input		
TK0 - TK2	Transmit Clock	I/O		
RK0 - RK2	Receive Clock	I/O		
TF0 - TF2	Transmit Frame Sync	I/O		
RF0 - RF2	Receive Frame Sync	I/O		
Timer/Counter				
TCLK0 - TCLK2	External Clock Input	Input		
TIOA0 - TIOA2	I/O Line A	I/O		
TIOB0 - TIOB2	I/O Line B	I/O		
SPI				
SPI0_MISO - SPI1_MISO	Master In Slave Out	I/O		
SPI0_MOSI - SPI1_MOSI	Master Out Slave In	I/O		
SPI0_SPCK - SPI1_SPCK	SPI Serial Clock	I/O		
SPI0_NPCS0, SPI1_NPCS0	SPI Peripheral Chip Select 0	I/O	Low	
SPI0_NPCS1 - SPI0_NPCS3 SPI1_NPCS1 - SPI1_NPCS3	SPI Peripheral Chip Select	Output	Low	
Two-Wire Interface				
TWD	Two-wire Serial Data	I/O		
TWCK	Two-wire Serial Clock	I/O		
LCD Controller				
LCDD0 - LCDD23	LCD Data Bus	Output		
LCDVSYNC	LCD Vertical Synchronization	Output		
LCDHSYNC	LCD Horizontal Synchronization	Output		
LCDDOTCK	LCD Dot Clock	Output		
LCDDEN	LCD Data Enable	Output		
LCDDCC	LCD Contrast Control	Output		
USB Device Port				
DDM	USB Device Port Data -	Analog		
DDP	USB Device Port Data +	Analog		



Table 3-1. Signal Description by Peripheral (Continued)

Signal Name	Function	Type	Active Level	Comments
USB Host Port				
HDMA	USB Host Port A Data -	Analog		
HDP A	USB Host Port A Data +	Analog		
HDMB	USB Host Port B Data -	Analog		
HDPB	USB Host Port B Data +	Analog		



4. Package and Pinout

The AT91SAM9G10 is available in a 217-ball LFBGA RoHS-compliant package, 15 x 15 mm, 0.8 mm ball pitch

4.1 217-ball LFBGA Package Outline

Figure 4-1 shows the orientation of the 217-ball LFBGA Package.

A detailed mechanical description is given in the section “AT91SAM9G10 Mechanical Characteristics” of the product datasheet.

Figure 4-1. 217-ball LFBGA Package Outline (Top View)

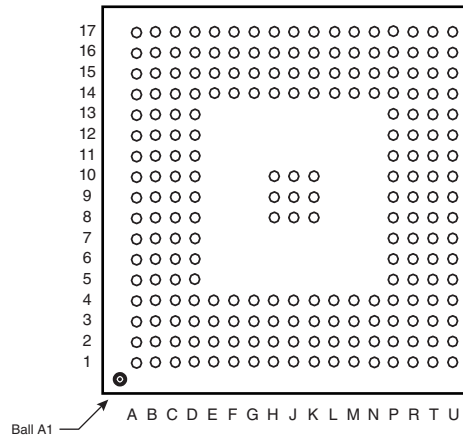

4.2 Pinout

Table 4-1. AT91SAM9G10 Pinout for 217-ball LFBGA Package ⁽¹⁾

Pin	Signal Name	Pin	Signal Name	Pin	Signal Name	Pin	Signal Name
A1	A19	D5	VDDCORE	J14	VDDIOP	P17	PA20
A2	A16/BA0	D6	A10	J15	PB9	R1	PC19
A3	A14	D7	A5	J16	PB6	R2	PC21
A4	A12	D8	A0/NBS0	J17	PB4	R3	GND
A5	A9	D9	SHDN	K1	D6	R4	PC27
A6	A6	D10	NC	K2	D8	R5	PC29
A7	A3	D11	VDDIOP	K3	D10	R6	PC4
A8	A2	D12	PB29	K4	D7	R7	PC8
A9	NC	D13	PB28	K8	GND	R8	PC12
A10	XOUT32	D14	PB23	K9	GND	R9	PC14
A11	XIN32	D15	PB20	K10	GND	R10	VDDPLL
A12	DDP	D16	PB17	K14	VDDCORE	R11	PA0
A13	HDPB	D17	TCK	K15	PB3/BMS	R12	PA7
A14	HDMB	E1	NWR1/NBS1/CFIOR	K16	PB1	R13	PA10
A15	PB27	E2	NWR0/NWE/CFWE	K17	PB2	R14	PA13
A16	GND	E3	NRD/CFOE	L1	D9	R15	PA17
A17	PB24	E4	SDA10	L2	D11	R16	GND
B1	A20	E14	PB22	L3	D12	R17	PA18
B2	A18	E15	PB18	L4	VDDIOM	T1	PC20
B3	A15	E16	PB15	L14	PA30	T2	PC23
B4	A13	E17	TDI	L15	PA27	T3	PC26
B5	A11	F1	SDCKE	L16	PA31	T4	PC2
B6	A7	F2	RAS	L17	PB0	T5	VDDIOP
B7	A4	F3	NWR3/NBS3/CFIOW	M1	D13	T6	PC5
B8	A1/NBS2/NWR2	F4	NCS0	M2	D15	T7	PC9
B9	VDDBU	F14	PB16	M3	PC18	T8	PC10
B10	JTAGSEL	F15	NRST	M4	VDDCORE	T9	PC15
B11	WKUP	F16	TDO	M14	PA25	T10	VDDOSC
B12	DDM	F17	NTRST	M15	PA26	T11	GNDOSC
B13	PB31	G1	D0	M16	PA28	T12	PA1
B14	HDMA	G2	D1	M17	PA29	T13	PA4
B15	PB26	G3	SDWE	N1	D14	T14	PA6
B16	PB25	G4	NCS3/NANDCS	N2	PC17	T15	PA8
B17	PB19	G14	PB14	N3	PC31	T16	PA11
C1	A22	G15	PB12	N4	VDDIOM	T17	PA14
C2	A21	G16	PB11	N14	PA22	U1	PC25
C3	VDDIOM	G17	PB8	N15	PA21	U2	PC0
C4	A17/BA1	H1	D2	N16	PA23	U3	PC3
C5	VDDIOM	H2	D3	N17	PA24	U4	GND
C6	A8	H3	VDDIOM	P1	PC16	U5	PC6
C7	GND	H4	SDCK	P2	PC30	U6	VDDIOP
C8	VDDIOM	H8	GND	P3	PC22	U7	GND
C9	GNDBU	H9	GND	P4	PC24	U8	PC13
C10	TST	H10	GND	P5	PC28	U9	PLLRCB
C11	GND	H14	PB10	P6	PC1	U10	PLLRCA
C12	HDPB	H15	PB13	P7	PC7	U11	XIN
C13	PB30	H16	PB7	P8	PC11	U12	XOUT
C14	NC	H17	PB5	P9	GNDPLL	U13	PA2
C15	VDDIOP	J1	D4	P10	PA3	U14	PA5
C16	PB21	J2	D5	P11	VDDIOP	U15	PA12
C17	TMS	J3	GND	P12	VDDCORE	U16	PA9
D1	NCS2	J4	CAS	P13	PA15	U17	RTCK
D2	NCS1/SDCS	J8	GND	P14	PA16		
D3	GND	J9	GND	P15	VDDIOP		
D4	VDDIOM	J10	GND	P16	PA19		

Note: 1. Shaded cells define the pins powered by VDDIOM.

5. Power Considerations

5.1 Power Supplies

The AT91SAM9G10 has six types of power supply pins:

- VDDCORE pins: Power the core, including the processor, the memories and the peripherals; voltage ranges from 1.08V and 1.32V, 1.2V nominal.
- VDDIOM pins: Power the External Bus Interface I/O lines; voltage ranges from 1.65V to 1.95V and 3.0V to 3.6V, 1.8V and 3.3V nominal.
- VDDIOP pins: Power the Peripheral I/O lines and the USB transceivers; voltage ranges from 2.7V and 3.6V, 3.3V nominal.
- VDDDBU pin: Powers the Slow Clock oscillator and a part of the System Controller; voltage ranges from 1.08V and 1.32V, 1.2V nominal.
- VDDPLL pin: Powers the PLL cells; voltage ranges from 3.0V and 3.6V, 3.3V nominal.
- VDDOSC pin: Powers the Main Oscillator cells; voltage ranges from 3.0V and 3.6V, 3.3V nominal.

The double power supplies VDDIOM and VDDIOP are identified in [Table 4-1 on page 10](#). These supplies enable the user to power the device differently for interfacing with memories and for interfacing with peripherals.

Ground pins GND are common to VDDCORE, VDDIOM and VDDIOP pins power supplies. Separated ground pins are provided for VDDDBU, VDDOSC and VDDPLL. The ground pins are GNDBU, GNDOSC and GNDPLL, respectively.

6. I/O Line Considerations

6.1 JTAG Port Pins

TMS, TDI and TCK are Schmitt trigger inputs and have no pull-up resistors.

TDO and RTCK are outputs, driven at up to VDDIOP, and have no pull-up resistor.

The JTAGSEL pin is used to select the JTAG boundary scan when asserted at a high level (tied to VDDDBU). It integrates a permanent pull-down resistor of about 15 k Ω to GNDBU, so that it can be left unconnected for normal operations.

The NTRST pin is used to initialize the embedded ICE TAP Controller when asserted at a low level. It integrates a permanent pull-up resistor of about 15 k Ω to VDDIOP, so that it can be left unconnected for normal operations.

6.2 Test Pin

The TST pin is used for manufacturing test purposes when asserted high. It integrates a permanent pull-down resistor of about 15 k Ω to GNDBU, so that it can be left unconnected for normal operations. Driving this line at a high level leads to unpredictable results.

6.3 Reset Pin

NRST is an open-drain output integrating a non-programmable pull-up resistor. It can be driven with voltage at up to VDDIOP. As the product integrates power-on reset cells, the NRST pin can be left unconnected in case no reset from the system needs to be applied to the product.



The NRST pin integrates a permanent pull-up resistor of 100 k Ω minimum to VDDIOP.

The NRST signal is inserted in the Boundary Scan.

6.4 PIO Controller A, B and C Lines

All the I/O lines PA0 to PA31, PB0 to PB31, and PC0 to PC31 integrate a programmable pull-up resistor of 100 k Ω . Programming of this pull-up resistor is performed independently for each I/O line through the PIO Controllers.

After reset, all the I/O lines default as inputs with pull-up resistors enabled, except those which are multiplexed with the External Bus Interface signals that require to be enabled as Peripherals at reset. This is explicitly indicated in the column "Reset State" of the PIO Controller multiplexing tables.

6.5 Shutdown Logic Pins

The SHDN pin is an output only, driven by Shutdown Controller.

The pin WKUP is an input only. It can accept voltages only between 0V and VDDBU.

7. Processor and Architecture

7.1 ARM926EJ-S Processor

- RISC Processor Based on ARM v5TEJ Architecture with Jazelle technology for Java acceleration
- Two Instruction Sets
 - ARM High-performance 32-bit Instruction Set
 - Thumb High Code Density 16-bit Instruction Set
- DSP Instruction Extensions
- 5-Stage Pipeline Architecture:
 - Instruction Fetch (F)
 - Instruction Decode (D)
 - Execute (E)
 - Data Memory (M)
 - Register Write (W)
- 16 Kbyte Data Cache, 16 Kbyte Instruction Cache
 - Virtually-addressed 4-way Associative Cache
 - Eight words per line
 - Write-through and Write-back Operation
 - Pseudo-random or Round-robin Replacement
- Write Buffer
 - Main Write Buffer with 16-word Data Buffer and 4-address Buffer
 - DCache Write-back Buffer with 8-word Entries and a Single Address Entry
 - Software Control Drain
- Standard ARM v4 and v5 Memory Management Unit (MMU)
 - Access Permission for Sections
 - Access Permission for large pages and small pages can be specified separately for each quarter of the page
 - 16 embedded domains
- Bus Interface Unit (BIU)
 - Arbitrates and Schedules AHB Requests
 - Separate Masters for both instruction and data access providing complete AHB system flexibility
 - Separate Address and Data Buses for both the 32-bit instruction interface and the 32-bit data interface
 - On Address and Data Buses, data can be 8-bit (Bytes), 16-bit (Half-words) or 32-bit (Words)

7.2 Debug and Test Features

- Integrated Embedded In-circuit Emulator Real-Time
 - Two real-time Watchpoint Units
 - Two Independent Registers: Debug Control Register and Debug Status Register
 - Test Access Port Accessible through JTAG Protocol
 - Debug Communications Channel
- Debug Unit
 - Two-pin UART
 - Debug Communication Channel Interrupt Handling
 - Chip ID Register
- IEEE1149.1 JTAG Boundary-scan on All Digital Pins

7.3 Bus Matrix

- Five Masters and Five Slaves handled
 - Handles Requests from the ARM926EJ-S, USB Host Port, LCD Controller and the Peripheral DMA Controller to internal ROM, internal SRAM, EBI, APB, LCD Controller and USB Host Port.
 - Round-Robin Arbitration (three modes supported: no default master, last accessed default master, fixed default master)
 - Burst Breaking with Slot Cycle Limit
- One Address Decoder Provided per Master
 - Three different slaves may be assigned to each decoded memory area: one for internal boot, one for external boot, one after remap.
- Boot Mode Select Option
 - Non-volatile Boot Memory can be Internal or External.
 - Selection is made by BMS pin sampled at reset.
- Remap Command
 - Allows Remapping of an Internal SRAM in Place of the Boot Non-Volatile Memory
 - Allows Handling of Dynamic Exception Vectors

7.4 Peripheral DMA Controller

- Transfers from/to peripheral to/from any memory space without intervention of the processor.
- Next Pointer Support, forbids strong real-time constraints on buffer management.
- Nineteen channels
 - Two for each USART
 - Two for the Debug Unit
 - Two for each Serial Synchronous Controller
 - Two for each Serial Peripheral Interface
 - One for the Multimedia Card Interface

8. Memories

Figure 8-1. AT91SAM9G10 Memory Mapping

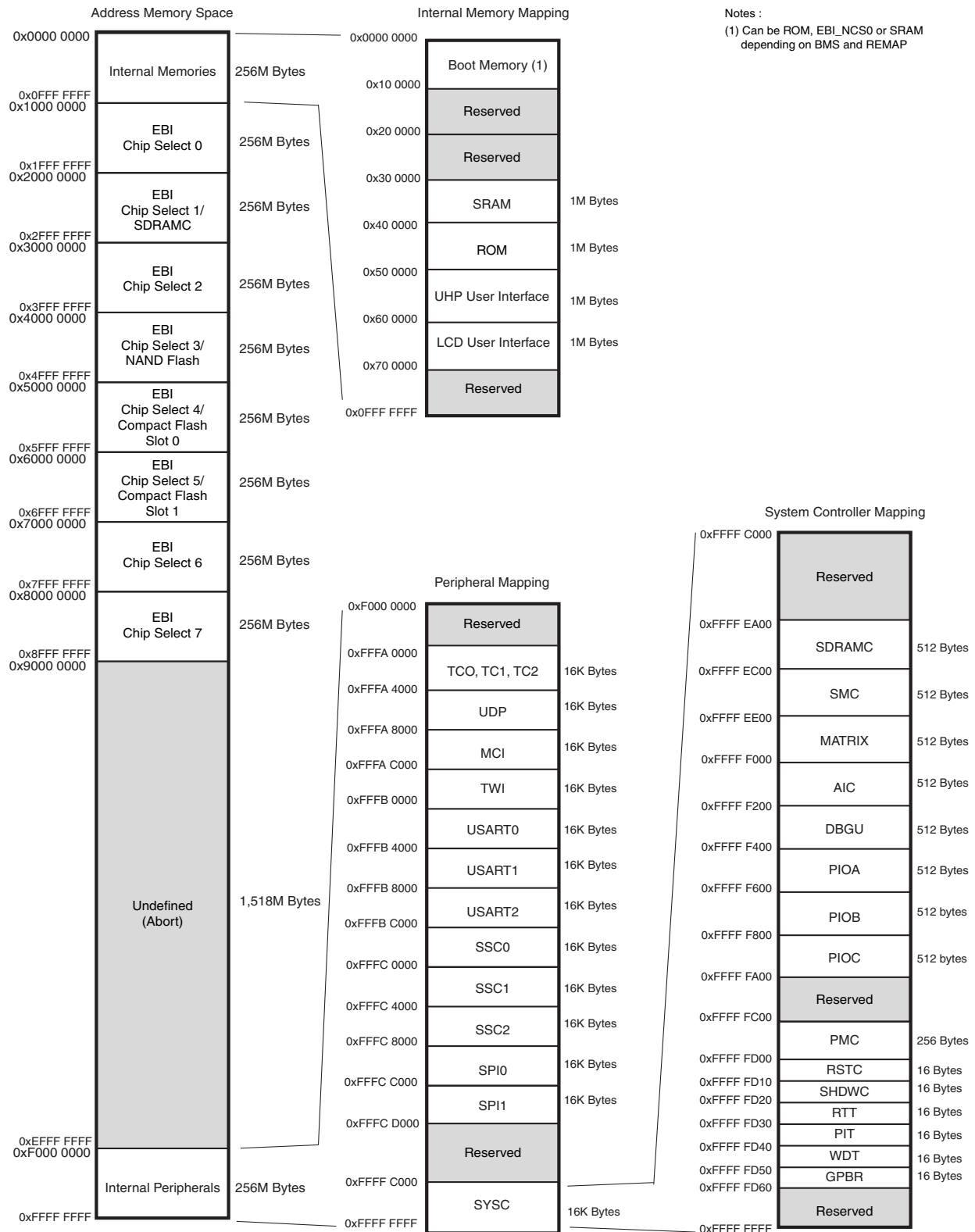

A first level of address decoding is performed by the Bus Matrix, i.e., the implementation of the Advanced High performance Bus (AHB) for its Master and Slave interfaces with additional features.

Decoding breaks up the 4 Gbytes of address space into 16 areas of 256 Mbytes. The areas 1 to 8 are directed to the EBI that associates these areas to the external chip selects NCS0 to NCS7. The area 0 is reserved for the addressing of the internal memories, and a second level of decoding provides 1 Mbyte of internal memory area. The area 15 is reserved for the peripherals and provides access to the Advanced Peripheral Bus (APB).

Other areas are unused and performing an access within them provides an abort to the master requesting such an access.

The Bus Matrix manages five Masters and five Slaves.

Each Master has its own bus and its own decoder, thus allowing a different memory mapping per Master.

Regarding Master 0 and Master 1 (ARM926™ Instruction and Data), three different Slaves are assigned to the memory space decoded at address 0x0: one for internal boot, one for external boot, one after remap. Refer to [Table 8-3](#) for details.

Table 8-1. List of Bus Matrix Masters

Master 0	ARM926 Instruction
Master 1	ARM926 Data
Master 2	PDC
Master 3	LCD Controller
Master 4	USB Host

Each Slave has its own arbiter, thus allowing a different arbitration per Slave.

Table 8-2. List of Bus Matrix Slaves

Slave 0	Internal SRAM
Slave 1	Internal ROM
Slave 2	LCD Controller and USB Host Port Interfaces
Slave 3	External Bus Interface
Slave 4	Internal Peripherals

8.1 Embedded Memories

- 32 KB ROM
 - Single Cycle Access at full bus speed
- 16 KB Fast SRAM
 - Single Cycle Access at full bus speed

8.1.1 Internal Memory Mapping

Table 8-3 summarizes the Internal Memory Mapping for each Master, depending on the Remap status and the BMS state at reset.

Table 8-3. Internal Memory Mapping

Address	Master 0: ARM926 Instruction			Master 1: ARM926 Data		
	REMAP(RCB0) = 0		REMAP (RCB0) = 1	REMAP (RCB1) = 0		REMAP (RCB1) = 1
	BMS = 1	BMS = 0		BMS = 1	BMS = 0	
0x0000 0000	Int. ROM	EBI NCS0 ⁽¹⁾	Int. RAM C	Int. ROM	EBI NCS0 ⁽¹⁾	Int. RAM C

Note: 1. EBI NCS0 is to be connected to a 16-bit non-volatile memory. The access configuration is defined by the reset state of SMC Setup, SMC Pulse, SMC Cycle and SMC Mode CS0 registers.

8.1.1.1 Internal SRAM

The AT91SAM9G10 embeds a high-speed 16-Kbyte SRAM.

8.1.1.2 Internal ROM

The AT91SAM9G10 integrates a 32-Kbyte Internal ROM mapped at address 0x0040 0000. It is also accessible at address 0x0 after reset and before remap if the BMS is tied high during reset.

8.1.1.3 USB Host Port

The AT91SAM9G10 integrates a USB Host Port Open Host Controller Interface (OHCI). The registers of this interface are directly accessible on the AHB Bus and are mapped like a standard internal memory at address 0x0050 0000.

8.1.1.4 LCD Controller

The AT91SAM9G10 integrates an LCD Controller. The interface is directly accessible on the AHB Bus and is mapped like a standard internal memory at address 0x0060 0000.

8.1.2 Boot Strategies

The system always boots at address 0x0. To ensure a maximum number of possibilities for boot, the memory layout can be configured with two parameters.

REMAP allows the user to lay out the first internal SRAM bank to 0x0 to ease development. This is done by software once the system has booted for each Master of the Bus Matrix. Refer to the Bus Matrix Section for more details.

When REMAP = 0, BMS allows the user to lay out to 0x0, at his convenience, the ROM or an external memory. This is done via hardware at reset.

Note: Memory blocks not affected by these parameters can always be seen at their specified base addresses. See the complete memory map presented in [Figure 8-1 on page 15](#).

The AT91SAM9G10 Bus Matrix manages a boot memory that depends on the level on the BMS pin at reset. The internal memory area mapped between address 0x0 and 0x000F FFFF is reserved for this purpose.

If BMS is detected at 1, the boot memory is the embedded ROM.

If BMS is detected at 0, the boot memory is the memory connected on the Chip Select 0 of the External Bus Interface.

8.1.2.1 *BMS = 1, Boot on Embedded ROM*

The system boots using the Boot Program.

- Enable the 32,768 Hz oscillator
- Auto baudrate detection
- Downloads and runs an application from external storage media into internal SRAM
- Automatic detection of valid application
- Bootloader on a non-volatile memory
 - SPI Serial Flash or DataFlash® connected on NPCS0 of the SPI0
 - NAND Flash
 - SDCard (boot ROM does not support high-capacity SDCards)
- SAM-BA Boot in case no valid program is detected in external NVM, supporting
 - Serial communication on a DBGU
 - USB Device HS Port

8.1.2.2 *BMS = 0, Boot on External Memory*

- Boot on slow clock (32,768 Hz)
- Boot with the default configuration for the Static Memory Controller, byte select mode, 16-bit data bus, Read/Write controlled by Chip Select, allows boot on 16-bit non-volatile memory.

The customer-programmed software must perform a complete configuration.

To speed up the boot sequence when booting at 32 kHz EBI CS0 (BMS=0), the user must take the following steps:

1. Program the PMC (main oscillator enable or bypass mode).
2. Program and start the PLL.
3. Reprogram the SMC setup, cycle, hold, mode timings registers for CS0 to adapt them to the new clock
4. Switch the main clock to the new value.

8.2 External Memories

The external memories are accessed through the External Bus Interface (Bus Matrix Slave 3).

Refer to the memory map in [Figure 8-1 on page 15](#).

9. System Controller

The System Controller manages all vital blocks of the microcontroller: interrupts, clocks, power, time, debug and reset.

The System Peripherals are all mapped within the highest 6 Kbytes of address space, between addresses 0xFFFF EA00 and 0xFFFF FFFF. Each peripheral has an address space of 256 or 512 Bytes, representing 64 or 128 registers.

[Figure 9-1 on page 20](#) shows the System Controller block diagram.

[Figure 8-1 on page 15](#) shows the mapping of the User Interfaces of the System Controller peripherals.

9.1 Block Diagram

Figure 9-1. System Controller Block Diagram

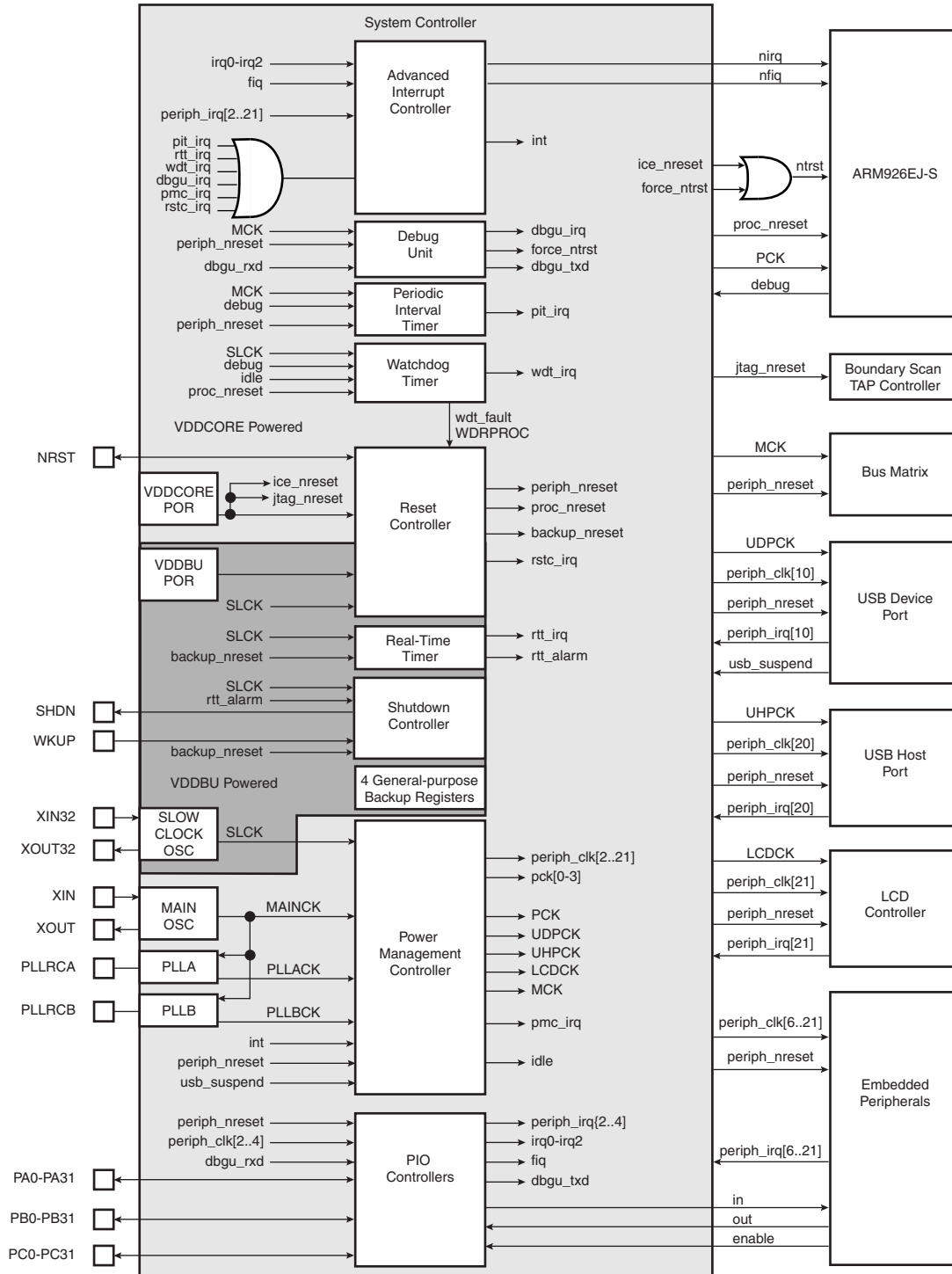

9.2 Reset Controller

- Based on two Power-on-Reset cells
- Status of the last reset
 - Either cold reset, first reset, soft reset, user reset, watchdog reset, wake-up reset
- Controls the internal resets and the NRST pin output

9.3 Shutdown Controller

- Shutdown and Wake-up logic:
 - Software programmable assertion of the SHDN pin
 - Deassertion Programmable on a WKUP pin level change or on alarm

9.4 General-purpose Backup Registers

- Four 32-bit general-purpose backup registers

9.5 Clock Generator

- Embeds the Low-power 32,768 Hz Slow Clock Oscillator
 - Provides the permanent Slow Clock to the system
- Embeds the Main Oscillator
 - Oscillator bypass feature
 - Supports 3 to 20 MHz crystals
- Embeds Two PLLs
 - Outputs 80 to 300 MHz clocks
 - Integrates an input divider to increase output accuracy
 - 1 MHz minimum input frequency
- Provides SLCK, MAINCK, PLLACK and PLLBCK.

Figure 9-2. Clock Generator Block Diagram

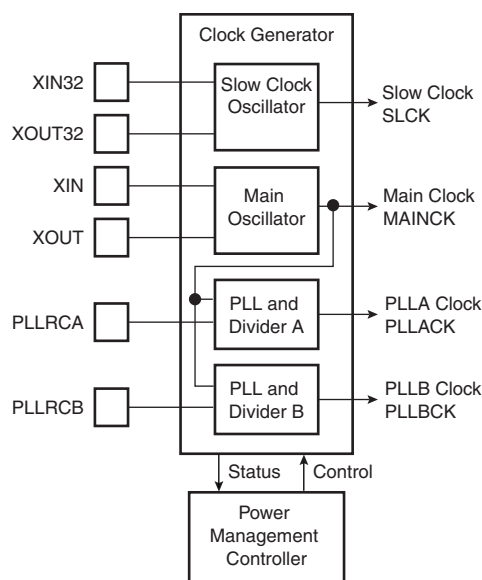

9.6 Power Management Controller

- The Power Management Controller provides:
 - the Processor Clock PCK
 - the Master Clock MCK
 - the USB Clock USBCK (HCK0)
 - the LCD Controller Clock LCDCK (HCK1)
 - up to thirty peripheral clocks
 - four programmable clock outputs: PCK0 to PCK3

Figure 9-3. Power Management Controller Block Diagram

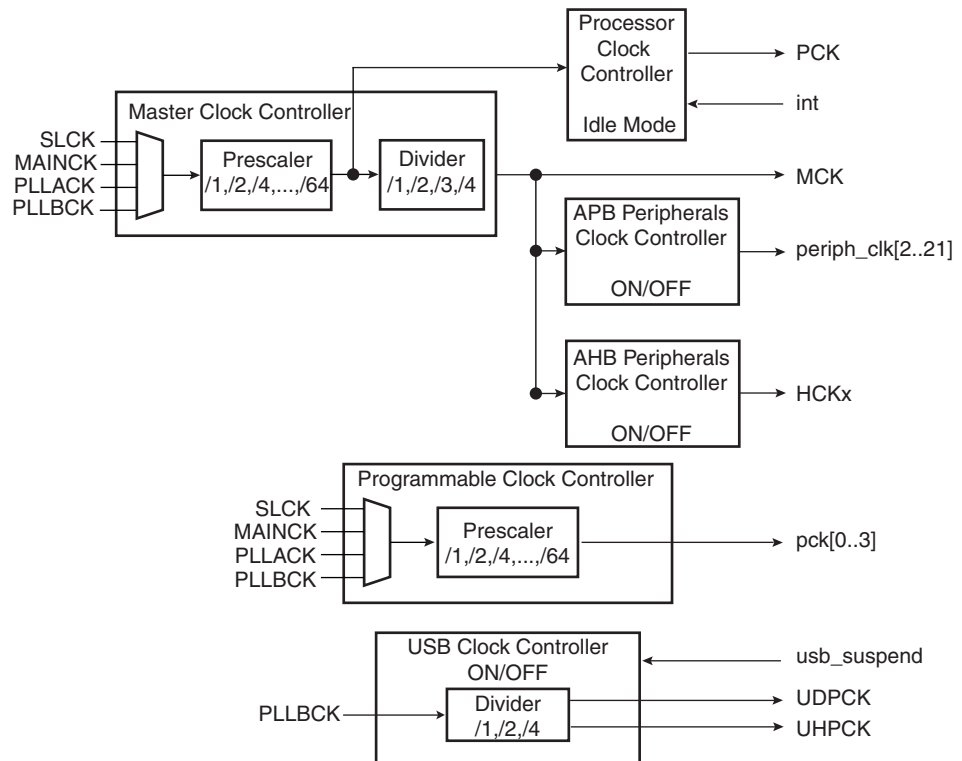

9.7 Periodic Interval Timer

- Includes a 20-bit Periodic Counter with less than 1 μ s accuracy
- Includes a 12-bit Interval Overlay Counter
- Real time OS or Linux[®]/WindowsCE[®] compliant tick generator

9.8 Watchdog Timer

- 12-bit key-protected only-once programmable counter
- Windowed, prevents the processor to be in a dead-lock on the watchdog access

9.9 Real-time Timer

- 32-bit Free-running backup counter
- Alarm Register capable to generate a wake-up of the system

9.10 Advanced Interrupt Controller

- Controls the interrupt lines (nIRQ and nFIQ) of an ARM Processor
- Thirty-two individually maskable and vectored interrupt sources
 - Source 0 is reserved for the Fast Interrupt Input (FIQ)
 - Source 1 is reserved for system peripherals (PIT, RTT, PMC, DBGU, etc.)
 - Source 2 to Source 31 control up to thirty embedded peripheral interrupts or external interrupts
 - Programmable edge-triggered or level-sensitive internal sources
 - Programmable positive/negative edge-triggered or high/low level-sensitive
- Four External Sources
- 8-level Priority Controller
 - Drives the normal interrupt of the processor
 - Handles priority of the interrupt sources 1 to 31
 - Higher priority interrupts can be served during service of lower priority interrupt
- Vectoring
 - Optimizes Interrupt Service Routine Branch and Execution
 - One 32-bit Vector Register per interrupt source
 - Interrupt Vector Register reads the corresponding current Interrupt Vector
- Protect Mode
 - Easy debugging by preventing automatic operations when protect mode is enabled
- Fast Forcing
 - Permits redirecting any normal interrupt source on the Fast Interrupt of the processor
- General Interrupt Mask
 - Provides processor synchronization on events without triggering an interrupt

9.11 Debug Unit

- Composed of four functions
 - Two-pin UART
 - Debug Communication Channel (DCC) support
 - Chip ID Registers
 - ICE Access Prevention
- Two-pin UART
 - Implemented features are 100% compatible with the standard Atmel USART
 - Independent receiver and transmitter with a common programmable Baud Rate Generator
 - Even, Odd, Mark or Space Parity Generation
 - Parity, Framing and Overrun Error Detection
 - Automatic Echo, Local Loopback and Remote Loopback Channel Modes
 - Support for two PDC channels with connection to receiver and transmitter
- Debug Communication Channel Support

- Offers visibility of COMMRX and COMMTX signals from the ARM Processor
- Chip ID Registers
 - Identification of the device revision, sizes of the embedded memories, set of peripherals
- ICE Access prevention
 - Enables software to prevent system access through the ARM Processor's ICE
 - Prevention is made by asserting the NTRST line of the ARM Processor's ICE

9.12 PIO Controllers

- Three PIO Controllers, each controlling up to 32 programmable I/O Lines
 - PIOA has 32 I/O Lines
 - PIOB has 32 I/O Lines
 - PIOC has 32 I/O Lines
- Fully programmable through Set/Clear Registers
- Multiplexing of two peripheral functions per I/O Line
- For each I/O Line (whether assigned to a peripheral or used as general-purpose I/O)
 - Input change interrupt
 - Glitch filter
 - Multi-drive option enables driving in open drain
 - Programmable pull up on each I/O line
 - Pin data status register, supplies visibility of the level on the pin at any time
- Synchronous output, provides Set and Clear of several I/O lines in a single write

10. Peripherals

10.1 User Interface

The User Peripherals are mapped in the upper 256 Mbytes of the address space between the addresses 0xFFFA 0000 and 0xFFFC FFFF. Each User Peripheral is allocated 16 Kbytes of address space.

A complete memory map is presented in [Figure 8-1 on page 15](#).

10.2 Peripheral Identifiers

[Table 10-1](#) defines the Peripheral Identifiers of the AT91SAM9G10. A peripheral identifier is required for the control of the peripheral interrupt with the Advanced Interrupt Controller and for the control of the peripheral clock with the Power Management Controller.

Table 10-1. Peripheral Identifiers

Peripheral ID	Peripheral Mnemonic	Peripheral Name	External Interrupt
0	AIC	Advanced Interrupt Controller	FIQ
1	SYSIRQ	System Interrupt	
2	PIOA	Parallel I/O Controller A	
3	PIOB	Parallel I/O Controller B	
4	PIOC	Parallel I/O Controller C	
5	-	Reserved	
6	US0	USART 0	
7	US1	USART 1	
8	US2	USART 2	
9	MCI	Multimedia Card Interface	
10	UDP	USB Device Port	
11	TWI	Two-Wire Interface	
12	SPI0	Serial Peripheral Interface 0	
13	SPI1	Serial Peripheral Interface 1	
14	SSC0	Synchronous Serial Controller 0	
15	SSC1	Synchronous Serial Controller 1	
16	SSC2	Synchronous Serial Controller 2	
17	TC0	Timer/Counter 0	
18	TC1	Timer/Counter 1	
19	TC2	Timer/Counter 2	
20	UHP	USB Host Port	
21	LCDC	LCD Controller	
22 - 28	-	Reserved	
29	AIC	Advanced Interrupt Controller	IRQ0
30	AIC	Advanced Interrupt Controller	IRQ1
31	AIC	Advanced Interrupt Controller	IRQ2

Note: Setting AIC, SYSIRQ, UHP, LCDC and IRQ0 to IRQ2 bits in the clock set/clear registers of the PMC has no effect.

10.3 Peripheral Multiplexing on PIO Lines

The AT91SAM9G10 features three PIO controllers, PIOA, PIOB and PIOC, that multiplex the I/O lines of the peripheral set.

Each PIO Controller controls up to thirty-two lines. Each line can be assigned to one of two peripheral functions, A or B. [Table 10-2 on page 28](#), [Table 10-3 on page 29](#) and [Table 10-4 on page 30](#) define how the I/O lines of the peripherals A and B are multiplexed on the PIO Controllers. The two columns “Function” and “Comments” have been inserted for the user’s own comments; they may be used to track how pins are defined in an application.

Note that some output only peripheral functions might be duplicated within the tables.

The column “Reset State” indicates whether the PIO line resets in I/O mode or in peripheral mode. If I/O is mentioned, the PIO line resets in input with the pull-up enabled, so that the device is maintained in a static state as soon as the reset is released. As a result, the bit corresponding to the PIO line in the register PIO_PSR (Peripheral Status Register) resets low.

If a signal name is mentioned in the “Reset State” column, the PIO line is assigned to this function and the corresponding bit in PIO_PSR resets high. This is the case of pins controlling memories, in particular the address lines, which require the pin to be driven as soon as the reset is released. Note that the pull-up resistor is also enabled in this case.

10.3.1 Resource Multiplexing

10.3.1.1 LCD Controller

The LCD Controller can interface with several LCD panels. It supports 4, 8 or 16 bit-per-pixel without any limitation. Interfacing 24 bit-per-pixel TFTs panel prevents using the SSC0 and the chip select line 0 of the SPI1.

16 bit-per-pixel TFT panels are interfaced through peripheral B functions, as color data is output on LCDD3 to LCDD7, LCDD11 to LCDD15 and LCDD19 to LCDD23. Intensity bit is output on LCDD2, LCDD10 and LCDD18. Using the peripheral B does not prevent using the SSC0 and the SPI1 lines.

10.3.1.2 EBI

If not required, the NWAIT function (external wait request) can be deactivated by software, allowing this pin to be used as a PIO.

10.3.1.3 32-bit Data Bus

Using a 32-bit Data Bus prevents:

- using the three Timer Counter channels’ outputs and trigger inputs
- using the SSC2

10.3.1.4 NAND Flash Interface

Using the NAND Flash interface prevents:

- using NCS3, NCS6 and NCS7 to access other parallel devices

10.3.1.5 Compact Flash Interface

Using the CompactFlash interface prevents:

- using NCS4 and/or NCS5 to access other parallel devices

10.3.1.6 *SPI0 and the MultiMedia Card Interface*

As the DataFlash Card is compatible with the SDCard, it is useful to multiplex SPI and MCI. Here, the SPI0 signal is multiplexed with the MCI.

10.3.1.7 *USARTs*

- Using USART0 with its control signals prevents using some clock outputs and interrupt lines.

10.3.1.8 *Clock Outputs*

- Using the clock outputs multiplexed with the PIO A prevents using the Debug Unit and/or the Two Wire Interface.
- Alternatively, using the second implementation of the clock outputs prevents using the LCD Controller Interface and/or USART0.

10.3.1.9 *Interrupt Lines*

- Using FIQ prevents using the USART0 control signals.
- Using IRQ0 prevents using the NWAIT EBI signal.
- Using the IRQ1 and/or IRQ2 prevents using the SPI1.

10.3.2 PIO Controller A Multiplexing

Table 10-2. Multiplexing on PIO Controller A

PIO Controller A					Application Usage		
I/O Line	Peripheral A	Peripheral B	Comments	Reset State	Power Supply	Function	Comments
PA0	SPI0_MISO	MCDA0		I/O	VDDIOP		
PA1	SPI0_MOSI	MCCDA		I/O	VDDIOP		
PA2	SPI0_SPCK	MCCK		I/O	VDDIOP		
PA3	SPI0_NPCS0			I/O	VDDIOP		
PA4	SPI0_NPCS1	MCDA1		I/O	VDDIOP		
PA5	SPI0_NPCS2	MCDA2		I/O	VDDIOP		
PA6	SPI0_NPCS3	MCDA3		I/O	VDDIOP		
PA7	TWD	PCK0		I/O	VDDIOP		
PA8	TWCK	PCK1		I/O	VDDIOP		
PA9	DRXD	PCK2		I/O	VDDIOP		
PA10	DTXD	PCK3		I/O	VDDIOP		
PA11	TSYNC	SCK1		I/O	VDDIOP		
PA12	TCLK	RTS1		I/O	VDDIOP		
PA13	TPS0	CTS1		I/O	VDDIOP		
PA14	TPS1	SCK2		I/O	VDDIOP		
PA15	TPS2	RTS2		I/O	VDDIOP		
PA16	TPK0	CTS2		I/O	VDDIOP		
PA17	TPK1	TF1		I/O	VDDIOP		
PA18	TPK2	TK1		I/O	VDDIOP		
PA19	TPK3	TD1		I/O	VDDIOP		
PA20	TPK4	RD1		I/O	VDDIOP		
PA21	TPK5	RK1		I/O	VDDIOP		
PA22	TPK6	RF1		I/O	VDDIOP		
PA23	TPK7	RTS0		I/O	VDDIOP		
PA24	TPK8	SPI1_NPCS1		I/O	VDDIOP		
PA25	TPK9	SPI1_NPCS2		I/O	VDDIOP		
PA26	TPK10	SPI1_NPCS3		I/O	VDDIOP		
PA27	TPK11	SPI0_NPCS1		I/O	VDDIOP		
PA28	TPK12	SPI0_NPCS2		I/O	VDDIOP		
PA29	TPK13	SPI0_NPCS3		I/O	VDDIOP		
PA30	TPK14	A23		A23	VDDIOM		
PA31	TPK15	A24		A24	VDDIOM		

10.3.3 PIO Controller B Multiplexing

Table 10-3. Multiplexing on PIO Controller B

PIO Controller B					Application Usage		
I/O Line	Peripheral A	Peripheral B	Comments	Reset State	Power Supply	Function	Comments
PB0	LCDVSYNC			I/O	VDDIOP		
PB1	LCDHSYNC			I/O	VDDIOP		
PB2	LCDDOTCK	PCK0		I/O	VDDIOP		
PB3 ⁽¹⁾	LCDDEN		See footnote ⁽¹⁾	I/O	VDDIOP		
PB4	LCDDCC	LCDD2		I/O	VDDIOP		
PB5	LCDD0	LCDD3		I/O	VDDIOP		
PB6	LCDD1	LCDD4		I/O	VDDIOP		
PB7	LCDD2	LCDD5		I/O	VDDIOP		
PB8	LCDD3	LCDD6		I/O	VDDIOP		
PB9	LCDD4	LCDD7		I/O	VDDIOP		
PB10	LCDD5	LCDD10		I/O	VDDIOP		
PB11	LCDD6	LCDD11		I/O	VDDIOP		
PB12	LCDD7	LCDD12		I/O	VDDIOP		
PB13	LCDD8	LCDD13		I/O	VDDIOP		
PB14	LCDD9	LCDD14		I/O	VDDIOP		
PB15	LCDD10	LCDD15		I/O	VDDIOP		
PB16	LCDD11	LCDD19		I/O	VDDIOP		
PB17	LCDD12	LCDD20		I/O	VDDIOP		
PB18	LCDD13	LCDD21		I/O	VDDIOP		
PB19	LCDD14	LCDD22		I/O	VDDIOP		
PB20	LCDD15	LCDD23		I/O	VDDIOP		
PB21	TF0	LCDD16		I/O	VDDIOP		
PB22	TK0	LCDD17		I/O	VDDIOP		
PB23	TD0	LCDD18		I/O	VDDIOP		
PB24	RD0	LCDD19		I/O	VDDIOP		
PB25	RK0	LCDD20		I/O	VDDIOP		
PB26	RF0	LCDD21		I/O	VDDIOP		
PB27	SPI1_NPCS1	LCDD22		I/O	VDDIOP		
PB28	SPI1_NPCS0	LCDD23		I/O	VDDIOP		
PB29	SPI1_SPCK	IRQ2		I/O	VDDIOP		
PB30	SPI1_MISO	IRQ1		I/O	VDDIOP		
PB31	SPI1_MOSI	PCK2		I/O	VDDIOP		

Note: 1. PB3 is multiplexed with BMS signal. Care should be taken during reset time.

10.3.4 PIO Controller C Multiplexing

Table 10-4. Multiplexing on PIO Controller C

PIO Controller C					Application Usage		
I/O Line	Peripheral A	Peripheral B	Comments	Reset State	Power Supply	Function	Comments
PC0	NANDOE	NCS6		I/O	VDDIOM		
PC1	NANDWE	NCS7		I/O	VDDIOP		
PC2	NWAIT	IRQ0		I/O	VDDIOP		
PC3	A25/CFRNW			A25	VDDIOP		
PC4	NCS4/CFCS0			I/O	VDDIOP		
PC5	NCS5/CFCS1			I/O	VDDIOP		
PC6	CFCE1			I/O	VDDIOP		
PC7	CFCE2			I/O	VDDIOM		
PC8	TXD0	PCK2		I/O	VDDIOP		
PC9	RXD0	PCK3		I/O	VDDIOP		
PC10	RTS0	SCK0		I/O	VDDIOP		
PC11	CTS0	FIQ		I/O	VDDIOP		
PC12	TXD1	NCS6		I/O	VDDIOP		
PC13	RXD1	NCS7		I/O	VDDIOP		
PC14	TXD2	SPI1_NPCS2		I/O	VDDIOP		
PC15	RXD2	SPI1_NPCS3		I/O	VDDIOP		
PC16	D16	TCLK0		I/O	VDDIOM		
PC17	D17	TCLK1		I/O	VDDIOM		
PC18	D18	TCLK2		I/O	VDDIOM		
PC19	D19	TIOA0		I/O	VDDIOM		
PC20	D20	TIOB0		I/O	VDDIOM		
PC21	D21	TIOA1		I/O	VDDIOM		
PC22	D22	TIOB1		I/O	VDDIOM		
PC23	D23	TIOA2		I/O	VDDIOM		
PC24	D24	TIOB2		I/O	VDDIOM		
PC25	D25	TF2		I/O	VDDIOM		
PC26	D26	TK2		I/O	VDDIOM		
PC27	D27	TD2		I/O	VDDIOM		
PC28	D28	RD2		I/O	VDDIOM		
PC29	D29	RK2		I/O	VDDIOM		
PC30	D30	RF2		I/O	VDDIOM		
PC31	D31	PCK1		I/O	VDDIOM		

10.3.5 System Interrupt

The System Interrupt in Source 1 is the wired-OR of the interrupt signals coming from:

- the SDRAM Controller
- the Debug Unit
- the Periodic Interval Timer
- the Real-Time Timer
- the Watchdog Timer
- the Reset Controller
- the Power Management Controller

The clock of these peripherals cannot be deactivated and Peripheral ID 1 can only be used within the Advanced Interrupt Controller.

10.3.6 External Interrupts

All external interrupt signals, i.e., the Fast Interrupt signal FIQ or the Interrupt signals IRQ0 to IRQ2, use a dedicated Peripheral ID. However, there is no clock control associated with these peripheral IDs.

10.4 External Bus Interface

- Integrates two External Memory Controllers:
 - Static Memory Controller
 - SDRAM Controller
- Additional logic for NAND Flash and CompactFlash support
 - NAND Flash support: 8-bit as well as 16-bit devices are supported
 - CompactFlash support: all modes (Attribute Memory, Common Memory, I/O, True IDE) are supported but the signals -IOIS16 (I/O and True IDE modes) and -ATA SEL (True IDE mode) are not handled.
- Optimized External Bus
 - 16- or 32-bit Data Bus
 - Up to 26-bit Address Bus, up to 64 Mbytes addressable
 - Eight Chip Selects, each reserved to one of the eight Memory Areas
 - Optimized pin multiplexing to reduce latencies on External Memories
- Configurable Chip Select Assignment Managed by EBI_CSA Register located in the MATRIX user interface
 - Static Memory Controller on NCS0
 - SDRAM Controller or Static Memory Controller on NCS1
 - Static Memory Controller on NCS2
 - Static Memory Controller on NCS3, Optional NAND Flash Support
 - Static Memory Controller on NCS4 - NCS5, Optional CompactFlash Support
 - Static Memory Controller on NCS6 - NCS7

10.5 Static Memory Controller

- External memory mapping, 256 Mbyte address space per Chip Select Line
- Up to Eight Chip Select Lines
- 8-, 16- or 32-bit Data Bus
- Multiple Access Modes supported
 - Byte Write or Byte Select Lines
 - Asynchronous read in Page Mode supported (4- up to 32-byte page size)
- Multiple device adaptability
 - Compliant with LCD Module
 - Control signal programmable setup, pulse and hold time for each Memory Bank
- Multiple Wait State Management
 - Programmable Wait State Generation
 - External Wait Request
 - Programmable Data Float Time
- Slow Clock Mode Supported

10.6 SDRAM Controller

- Supported Devices
 - Standard and Low Power SDRAM (Mobile SDRAM)
- Numerous configurations supported
 - 2K, 4K, 8K Row Address Memory Parts
 - SDRAM with two or four Internal Banks
 - SDRAM with 16- or 32-bit Data Path
- Programming Facilities
 - Word, half-word, byte access
 - Automatic page break when Memory Boundary has been reached
 - Multibank Ping-pong Access
 - Timing parameters specified by software
 - Automatic refresh operation, refresh rate is programmable
- Energy-saving Capabilities
 - Self-refresh, power down and deep power down modes supported
- Error detection
 - Refresh Error Interrupt
- SDRAM Power-up Initialization by software
- CAS Latency of 1, 2 and 3 supported
- Auto Precharge Command not used

10.7 Serial Peripheral Interface

- Supports communication with serial external devices
 - Four chip selects with external decoder support allow communication with up to fifteen peripherals
 - Serial memories, such as DataFlash and 3-wire EEPROMs
 - Serial peripherals, such as ADCs, DACs, LCD Controllers, CAN Controllers and Sensors
 - External co-processors
- Master or slave serial peripheral bus interface
 - 8- to 16-bit programmable data length per chip select
 - Programmable phase and polarity per chip select
 - Programmable transfer delays between consecutive transfers and between clock and data per chip select
 - Programmable delay between consecutive transfers
 - Selectable mode fault detection
- Very fast transfers supported
 - Transfers with baud rates up to MCK
 - The chip select line may be left active to speed up transfers on the same device

10.8 Two-wire Interface

- Compatibility with standard two-wire serial memories
- One, two or three bytes for slave address
- Sequential read/write operations
- Supports either master or slave modes
- Master, multi-master and slave mode operation
- Bit rate: up to 400 Kbits
- General call supported in slave mode

10.9 USART

- Programmable Baud Rate Generator
- 5- to 9-bit full-duplex synchronous or asynchronous serial communications
 - 1, 1.5 or 2 stop bits in Asynchronous Mode or 1 or 2 stop bits in Synchronous Mode
 - Parity generation and error detection
 - Framing error detection, overrun error detection
 - MSB- or LSB-first
 - Optional break generation and detection
 - By-8 or by-16 over-sampling receiver frequency
 - Hardware handshaking RTS-CTS
 - Receiver time-out and transmitter timeguard
 - Optional Multi-drop Mode with address generation and detection
 - Optional Manchester Encoding

- RS485 with driver control signal
- ISO7816, T = 0 or T = 1 Protocols for interfacing with smart cards
 - NACK handling, error counter with repetition and iteration limit
- IrDA modulation and demodulation
 - Communication at up to 115.2 Kbps
- Test Modes
 - Remote Loopback, Local Loopback, Automatic Echo

10.10 Synchronous Serial Controller

- Provides serial synchronous communication links used in audio and telecom applications (with CODECs in Master or Slave Modes, I²S, TDM Buses, Magnetic Card Reader and more).
- Contains an independent receiver and transmitter and a common clock divider.
- Offers a configurable frame sync and data length.
- Receiver and transmitter can be programmed to start automatically or on detection of different event on the frame sync signal.
- Receiver and transmitter include a data signal, a clock signal and a frame synchronization signal.

10.11 Timer Counter

- Three 16-bit Timer Counter Channels
- Wide range of functions including:
 - Frequency Measurement
 - Event Counting
 - Interval Measurement
 - Pulse Generation
 - Delay Timing
 - Pulse Width Modulation
 - Up/down Capabilities
- Each channel is user-configurable and contains:
 - Three external clock inputs
 - Five internal clock inputs
 - Two multi-purpose input/output signals
- Two global registers that act on all three TC Channels

10.12 MultiMediaCard Interface

- Two double-channel MultiMediaCard Interfaces, allowing concurrent transfers with 2 cards
- Compatibility with MultiMediaCard Specification Version 3.31
- Compatibility with SD Memory Card Specification Version 1.0
- Compatibility with SDIO Specification Version V1.1
- Cards clock rate up to Master Clock divided by 2
- Embedded power management to slow down clock rate when not used

- Each MCI has two slots, each supporting
 - One slot for one MultiMediaCard bus (up to 30 cards) or
 - One SD Memory Card
- Support for stream, block and multi-block data read and write

10.13 USB

- USB Host Port:
 - Compliance with Open HCI Rev 1.0 specification
 - Compliance with USB V2.0 Full-speed and Low-speed Specification
 - Supports both Low-speed 1.5 Mbps and Full-speed 12 Mbps USB devices
 - Root hub integrated with two downstream USB ports
 - Two embedded USB transceivers
 - No overcurrent detection
 - Supports power management
 - Operates as a master on the Bus Matrix
- USB Device Port:
 - USB V2.0 full-speed compliant, 12 Mbits per second
 - Embedded USB V2.0 full-speed transceiver
 - Embedded dual-port RAM for endpoints
 - Suspend/Resume logic
 - Ping-pong mode (two memory banks) for isochronous and bulk endpoints
 - Six general-purpose endpoints:
 - Endpoint 0: 8 bytes, no ping-pong mode
 - Endpoint 1, Endpoint 2: 64 bytes, ping-pong mode
 - Endpoint 3: 64 bytes, no ping-pong mode
 - Endpoint 4, Endpoint 5: 256 bytes, ping-pong mode
- Embedded pad pull-up configurable via USB_PUCR Register located in the MATRIX user interface

10.14 LCD Controller

- Single and Dual scan color and monochrome passive STN LCD panels supported
- Single scan active TFT LCD panels supported.
- 4-bit single scan, 8-bit single or dual scan, 16-bit dual scan STN interfaces supported
- Up to 24-bit single scan TFT interfaces supported
- Up to 16 gray levels for mono STN and up to 4096 colors for color STN displays
- 1, 2 bits per pixel (palletized), 4 bits per pixel (non-palletized) for mono STN
- 1, 2, 4, 8 bits per pixel (palletized), 16 bits per pixel (non-palletized) for color STN
- 1, 2, 4, 8 bits per pixel (palletized), 16, 24 bits per pixel (non-palletized) for TFT
- Single clock domain architecture
- Resolution supported up to 1280 x 860

11. Package Drawing

Figure 11-1. 217-ball LFBGA Package Drawing

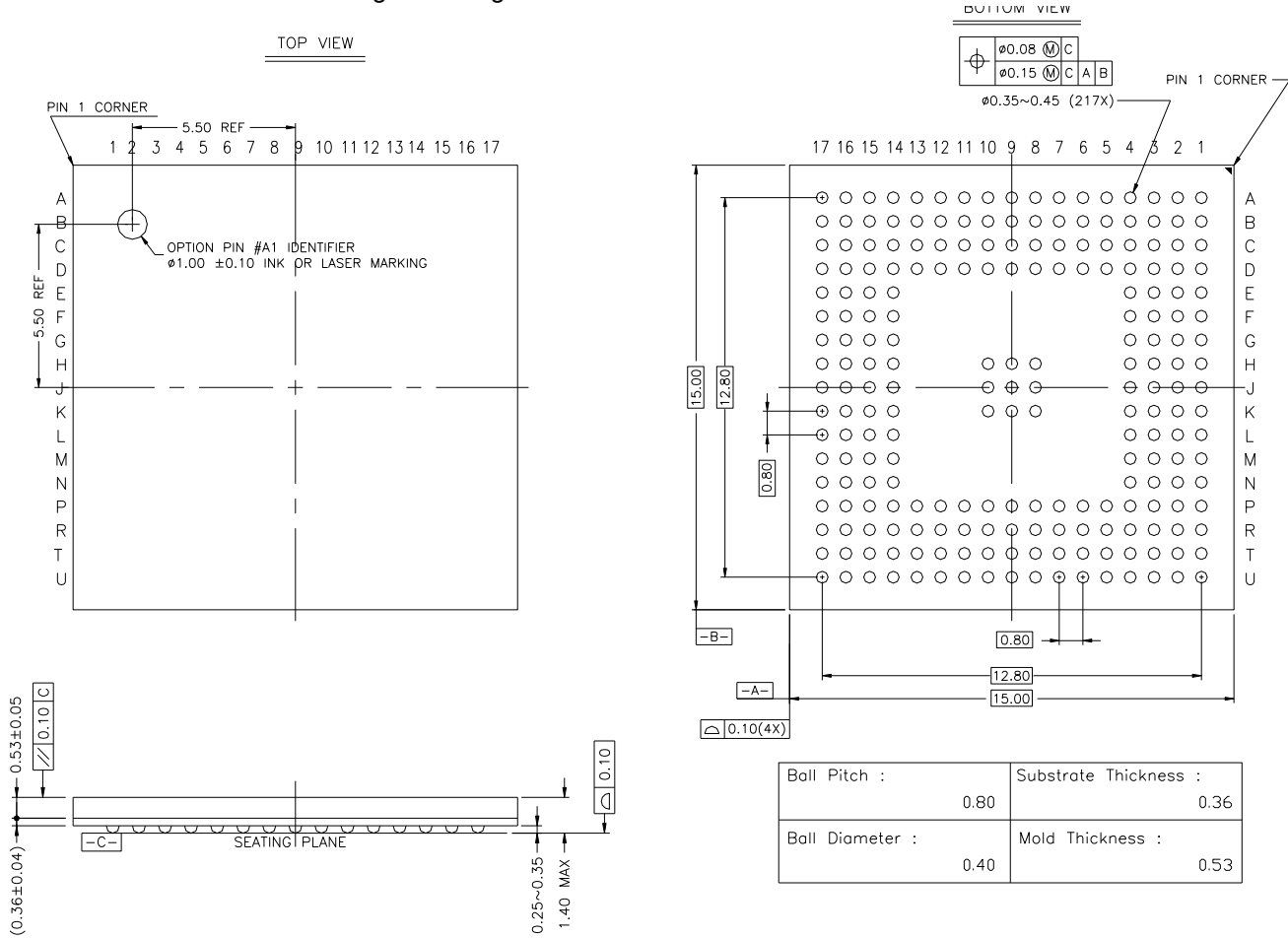

12. AT91SAM9G10 Ordering Information

Table 12-1. AT91SAM9G10 Ordering Information

Ordering Code	Package	Package Type	Temperature Operating Range
AT91SAM9G10-CU	BGA217	RoHS-compliant	Industrial -40°C to 85°C



Revision History

Doc. Rev	Comments	Change Request Ref.
6462AS	First issue	





Headquarters

Atmel Corporation
2325 Orchard Parkway
San Jose, CA 95131
USA
Tel: 1(408) 441-0311
Fax: 1(408) 487-2600

International

Atmel Asia
Unit 1-5 & 16, 19/F
BEA Tower, Millennium City 5
418 Kwun Tong Road
Kwun Tong, Kowloon
Hong Kong
Tel: (852) 2245-6100
Fax: (852) 2722-1369

Atmel Europe
Le Krebs
8, Rue Jean-Pierre Timbaud
BP 309
78054 Saint-Quentin-en-
Yvelines Cedex
France
Tel: (33) 1-30-60-70-00
Fax: (33) 1-30-60-71-11

Atmel Japan
9F, Tonetsu Shinkawa Bldg.
1-24-8 Shinkawa
Chuo-ku, Tokyo 104-0033
Japan
Tel: (81) 3-3523-3551
Fax: (81) 3-3523-7581

Product Contact

Web Site
www.atmel.com
www.atmel.com/AT91SAM

Technical Support
[AT91SAM Support](mailto:AT91SAM_Support@atmel.com)
[Atmel technical support](mailto:ATmel_techincal_support@atmel.com)

Sales Contacts
www.atmel.com/contacts/

Literature Requests
www.atmel.com/literature

Disclaimer: The information in this document is provided in connection with Atmel products. No license, express or implied, by estoppel or otherwise, to any intellectual property right is granted by this document or in connection with the sale of Atmel products. **EXCEPT AS SET FORTH IN ATMEL'S TERMS AND CONDITIONS OF SALE LOCATED ON ATMEL'S WEB SITE, ATMEL ASSUMES NO LIABILITY WHATSOEVER AND DISCLAIMS ANY EXPRESS, IMPLIED OR STATUTORY WARRANTY RELATING TO ITS PRODUCTS INCLUDING, BUT NOT LIMITED TO, THE IMPLIED WARRANTY OF MERCHANTABILITY, FITNESS FOR A PARTICULAR PURPOSE, OR NON-INFRINGEMENT. IN NO EVENT SHALL ATMEL BE LIABLE FOR ANY DIRECT, INDIRECT, CONSEQUENTIAL, PUNITIVE, SPECIAL OR INCIDENTAL DAMAGES (INCLUDING, WITHOUT LIMITATION, DAMAGES FOR LOSS OF PROFITS, BUSINESS INTERRUPTION, OR LOSS OF INFORMATION) ARISING OUT OF THE USE OR INABILITY TO USE THIS DOCUMENT, EVEN IF ATMEL HAS BEEN ADVISED OF THE POSSIBILITY OF SUCH DAMAGES.** Atmel makes no representations or warranties with respect to the accuracy or completeness of the contents of this document and reserves the right to make changes to specifications and product descriptions at any time without notice. Atmel does not make any commitment to update the information contained herein. Unless specifically provided otherwise, Atmel products are not suitable for, and shall not be used in, automotive applications. Atmel's products are not intended, authorized, or warranted for use as components in applications intended to support or sustain life.



© 2009 Atmel Corporation. All rights reserved. Atmel®, Atmel logo and combinations thereof, DataFlash®, SAM-BA® and others are registered trademarks or trademarks of Atmel Corporation or its subsidiaries. ARM®, the ARMPowered® logo, Thumb® and others are the registered trademarks or trademarks of ARM Ltd. Windows® and others are registered trademarks or trademarks of Microsoft Corporation in the US and/or other countries. Other terms and product names may be the trademarks of others.

Looking for pricing, stock, or lifecycle information?

Click below to explore more details on WIN SOURCE:

 [View AT91SAM9G10-CU on WIN SOURCE](#)

 [Atmel Information](#)

Optimize Your Supply Chain with WIN SOURCE Solutions

-  Global Sourcing Solution
-  Obsolete Management
-  Cost Control Management
-  Shortage Management
-  Alternative Solution
-  Excess Inventory Management