

## Features

- Incorporates the ARM7TDMI® ARM® Thumb® Processor
  - High-performance 32-bit RISC Architecture
  - High-density 16-bit Instruction Set
  - Leader in MIPS/Watt
  - EmbeddedICE™ In-circuit Emulation, Debug Communication Channel Support
- Internal High-speed Flash
  - 512 Kbytes (AT91SAM7XC512) Organized in Two Banks of 1024 Pages of 256 Bytes (Dual Plane)
  - 256 Kbytes (AT91SAM7XC256) Organized in 1024 Pages of 256 Bytes (Single Plane)
  - 128 Kbytes (AT91SAM7XC128) Organized in 512 Pages of 256 Bytes (Single Plane)
    - Single Cycle Access at Up to 30 MHz in Worst Case Conditions
    - Prefetch Buffer Optimizing Thumb Instruction Execution at Maximum Speed
    - Page Programming Time: 6 ms, Including Page Auto-erase, Full Erase Time: 15 ms
    - 10,000 Write Cycles, 10-year Data Retention Capability, Sector Lock Capabilities, Flash Security Bit
    - Fast Flash Programming Interface for High Volume Production
- Internal High-speed SRAM, Single-cycle Access at Maximum Speed
  - 128 Kbytes (AT91SAM7XC512)
  - 64 Kbytes (AT91SAM7XC256)
  - 32 Kbytes (AT91SAM7XC128)
- Memory Controller (MC)
  - Embedded Flash Controller, Abort Status and Misalignment Detection
- Reset Controller (RSTC)
  - Based on Power-on Reset Cells and Low-power Factory-calibrated Brownout Detector
  - Provides External Reset Signal Shaping and Reset Source Status
- Clock Generator (CKGR)
  - Low-power RC Oscillator, 3 to 20 MHz On-chip Oscillator and one PLL
- Power Management Controller (PMC)
  - Power Optimization Capabilities, Including Slow Clock Mode (Down to 500 Hz) and Idle Mode
  - Four Programmable External Clock Signals
- Advanced Interrupt Controller (AIC)
  - Individually Maskable, Eight-level Priority, Vectored Interrupt Sources
  - Two External Interrupt Sources and One Fast Interrupt Source, Spurious Interrupt Protected
- Debug Unit (DBGU)
  - 2-wire UART and Support for Debug Communication Channel interrupt, Programmable ICE Access Prevention
  - Mode for General Purpose 2-wire UART Serial Communication
- Periodic Interval Timer (PIT)
  - 20-bit Programmable Counter plus 12-bit Interval Counter
- Windowed Watchdog (WDT)
  - 12-bit Key-protected Programmable Counter
  - Provides Reset or Interrupt Signals to the System
  - Counter May Be Stopped While the Processor is in Debug State or in Idle Mode



## Product Description

**AT91SAM7XC512**  
**AT91SAM7XC258**  
**AT91SAM7XC128**

## Summary

**NOTE:** This is a summary document. The complete document is available on the Atmel website at [www.atmel.com](http://www.atmel.com).

6209DS-ATARM-17-Feb-09



- **Real-time Timer (RTT)**
  - 32-bit Free-running Counter with Alarm
  - Runs Off the Internal RC Oscillator
- **Two Parallel Input/Output Controllers (PIO)**
  - Sixty-two Programmable I/O Lines Multiplexed with up to Two Peripheral I/Os
  - Input Change Interrupt Capability on Each I/O Line
  - Individually Programmable Open-drain, Pull-up Resistor and Synchronous Output
- **Seventeen Peripheral DMA Controller (PDC) Channels**
- **One Advanced Encryption System (AES)**
  - 256-, 192-, 128-bit Key Algorithm, Compliant with FIPS PUB 197 Specifications (AT91SAM7XC512)
  - 128-bit Key Algorithm, Compliant with FIPS PUB 197 Specifications (AT91SAM7XC256/128)
  - Buffer Encryption/Decryption Capabilities with PDC
- **One Triple Data Encryption System (TDES)**
  - Two-key or Three-key Algorithms, Compliant with FIPS PUB 46-3 Specifications
  - Optimized for Triple Data Encryption Capability
- **One USB 2.0 Full Speed (12 Mbits per second) Device Port**
  - On-chip Transceiver, 1352-byte Configurable Integrated FIFOs
- **One Ethernet MAC 10/100 base-T**
  - Media Independent Interface (MII) or Reduced Media Independent Interface (RMII)
  - Integrated 28-byte FIFOs and Dedicated DMA Channels for Transmit and Receive
- **One Part 2.0A and Part 2.0B Compliant CAN Controller**
  - Eight Fully-programmable Message Object Mailboxes, 16-bit Time Stamp Counter
- **One Synchronous Serial Controller (SSC)**
  - Independent Clock and Frame Sync Signals for Each Receiver and Transmitter
  - I<sup>2</sup>S Analog Interface Support, Time Division Multiplex Support
  - High-speed Continuous Data Stream Capabilities with 32-bit Data Transfer
- **Two Universal Synchronous/Asynchronous Receiver Transmitters (USART)**
  - Individual Baud Rate Generator, IrDA Infrared Modulation/Demodulation
  - Support for ISO7816 T0/T1 Smart Card, Hardware Handshaking, RS485 Support
  - Full Modem Line Support on USART1
- **Two Master/Slave Serial Peripheral Interfaces (SPI)**
  - 8- to 16-bit Programmable Data Length, Four External Peripheral Chip Selects
- **One Three-channel 16-bit Timer/Counter (TC)**
  - Three External Clock Inputs, Two Multi-purpose I/O Pins per Channel
  - Double PWM Generation, Capture/Waveform Mode, Up/Down Capability
- **One Four-channel 16-bit Power Width Modulation Controller (PWMC)**
- **One Two-wire Interface (TWI)**
  - Master Mode Support Only, All Two-wire Atmel EEPROMs and I<sup>2</sup>C Compatible Devices Supported
- **One 8-channel 10-bit Analog-to-Digital Converter, Four Channels Multiplexed with Digital I/Os**
- **SAM-BA™ Boot Assistant**
  - Default Boot program
  - Interface with SAM-BA Graphic User Interface
- **IEEE 1149.1 JTAG Boundary Scan on All Digital Pins**
- **5V-tolerant I/Os, Including Four High-current Drive I/O lines, Up to 16 mA Each**
- **Power Supplies**
  - Embedded 1.8V Regulator, Drawing up to 100 mA for the Core and External Components
  - 3.3V VDDIO I/O Lines Power Supply, Independent 3.3V VDDFLASH Flash Power Supply
  - 1.8V VDDCORE Core Power Supply with Brownout Detector

- Fully Static Operation: Up to 55 MHz at 1.65V and 85° C Worst Case Conditions
- Available in 100-lead LQFP Green and 100-ball TFBGA Green Packages



# 1. Description

Atmel's AT91SAM7XC512/256/128 is a member of a series of highly integrated Flash microcontrollers based on the 32-bit ARM RISC processor. It features 512/256/128 Kbyte high-speed Flash and 128/64/32 Kbyte SRAM, a large set of peripherals, including an 802.3 Ethernet MAC, a CAN controller, an AES 128 Encryption accelerator and a Triple Data Encryption System. A complete set of system functions minimizes the number of external components.

The embedded Flash memory can be programmed in-system via the JTAG-ICE interface or via a parallel interface on a production programmer prior to mounting. Built-in lock bits and a security bit protect the firmware from accidental overwrite and preserve its confidentiality.

The AT91SAM7XC512/256/128 system controller includes a reset controller capable of managing the power-on sequence of the microcontroller and the complete system. Correct device operation can be monitored by a built-in brownout detector and a watchdog running off an integrated RC oscillator.

By combining the ARM7TDMI processor with on-chip Flash and SRAM, and a wide range of peripheral functions, including USART, SPI, CAN Controller, Ethernet MAC, AES 128 accelerator, TDES, Timer Counter, RTT and Analog-to-Digital Converters on a monolithic chip, the AT91SAM7XC512/256/128 is a powerful device that provides a flexible, cost-effective solution to many embedded control applications requiring secure communication over, for example, Ethernet, CAN wired and Zigbee™ wireless networks.

## 1.1 Configuration Summary of the AT91SAM7XC512/256/128

The AT91SAM7XC512, AT91SAM7XC256 and AT91SAM7XC128 differ only in memory sizes.

[Table 1-1](#) summarizes the configurations of the two devices.

**Table 1-1.** Configuration Summary

Device	Flash	Flash Organization	SRAM	AES	TDES
AT91SAM7XC512	512K bytes	dual plane	128K bytes	1 AES 256/192/128	1
AT91SAM7XC256	256K bytes	single plane	64K bytes	1 AES 128	1
AT91SAM7XC128	128K bytes	single plane	32K bytes	1 AES 128	1

## 2. AT91SAM7XC512/256/128 Block Diagram

Figure 2-1. AT91SAM7XC512/256/128 Block Diagram

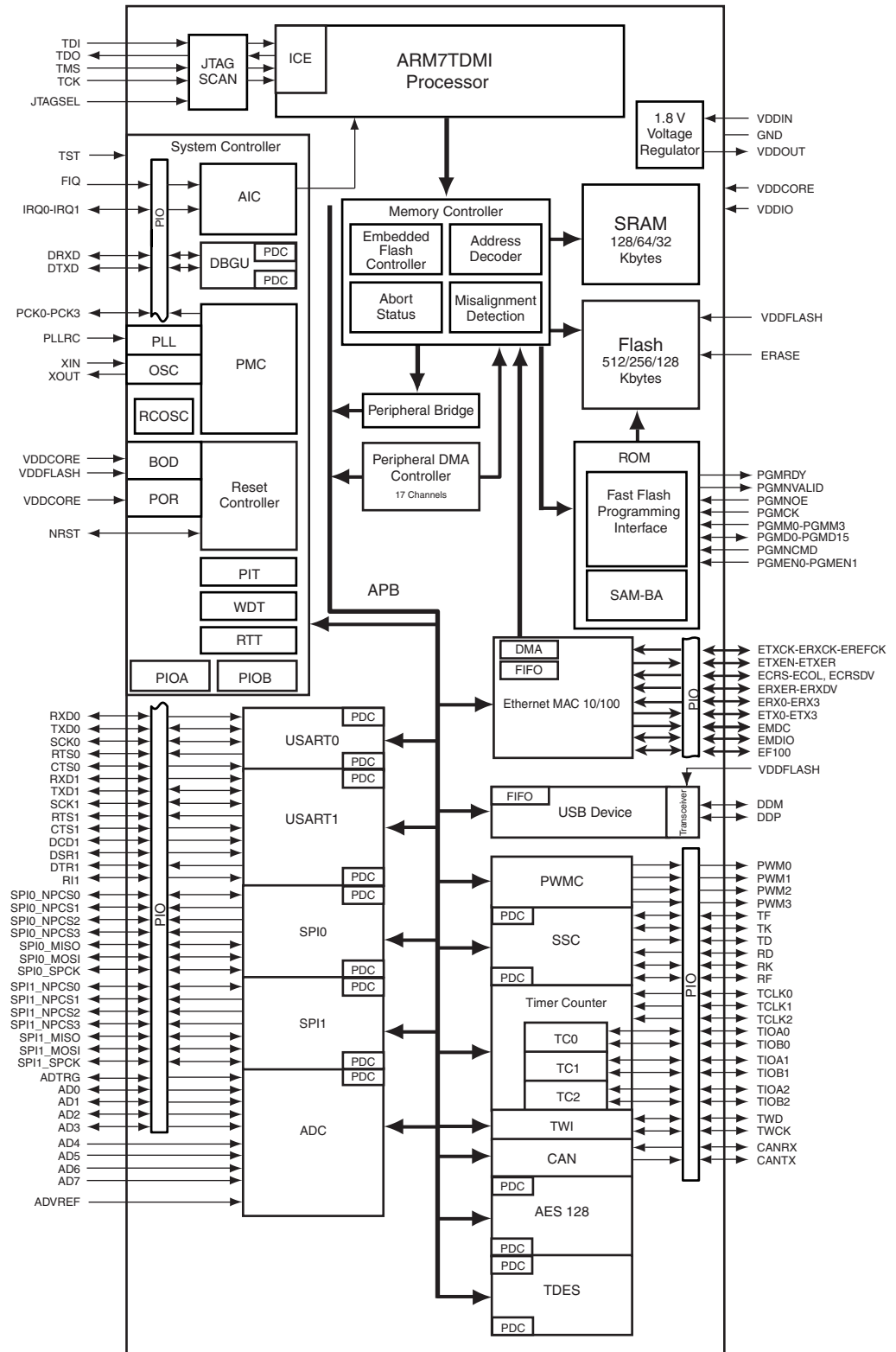

### 3. Signal Description

**Table 3-1.** Signal Description List

Signal Name	Function	Type	Active Level	Comments
<b>Power</b>				
VDDIN	Voltage Regulator and ADC Power Supply Input	Power		3V to 3.6V
VDDOUT	Voltage Regulator Output	Power		1.85V
VDDFLASH	Flash and USB Power Supply	Power		3V to 3.6V
VDDIO	I/O Lines Power Supply	Power		3V to 3.6V
VDDCORE	Core Power Supply	Power		1.65V to 1.95V
VDDPLL	PLL	Power		1.65V to 1.95V
GND	Ground	Ground		
<b>Clocks, Oscillators and PLLs</b>				
XIN	Main Oscillator Input	Input		
XOUT	Main Oscillator Output	Output		
PLLRC	PLL Filter	Input		
PCK0 - PCK3	Programmable Clock Output	Output		
<b>ICE and JTAG</b>				
TCK	Test Clock	Input		No pull-up resistor
TDI	Test Data In	Input		No pull-up resistor
TDO	Test Data Out	Output		
TMS	Test Mode Select	Input		No pull-up resistor
JTAGSEL	JTAG Selection	Input		Pull-down resistor <sup>(1)</sup>
<b>Flash Memory</b>				
ERASE	Flash and NVM Configuration Bits Erase Command	Input	High	Pull-down resistor <sup>(1)</sup>
<b>Reset/Test</b>				
NRST	Microcontroller Reset	I/O	Low	Pull-Up resistor, Open Drain Output.
TST	Test Mode Select	Input	High	Pull-down resistor <sup>(1)</sup>
<b>Debug Unit</b>				
DRXD	Debug Receive Data	Input		
DTXD	Debug Transmit Data	Output		
<b>AIC</b>				
IRQ0 - IRQ1	External Interrupt Inputs	Input		
FIQ	Fast Interrupt Input	Input		
<b>PIO</b>				
PA0 - PA30	Parallel IO Controller A	I/O		Pulled-up input at reset.
PB0 - PB30	Parallel IO Controller B	I/O		Pulled-up input at reset.

**Table 3-1.** Signal Description List (Continued)

Signal Name	Function	Type	Active Level	Comments
<b>USB Device Port</b>				
DDM	USB Device Port Data -	Analog		
DDP	USB Device Port Data +	Analog		
<b>USART</b>				
SCK0 - SCK1	Serial Clock	I/O		
TXD0 - TXD1	Transmit Data	I/O		
RXD0 - RXD1	Receive Data	Input		
RTS0 - RTS1	Request To Send	Output		
CTS0 - CTS1	Clear To Send	Input		
DCD1	Data Carrier Detect	Input		
DTR1	Data Terminal Ready	Output		
DSR1	Data Set Ready	Input		
RI1	Ring Indicator	Input		
<b>Synchronous Serial Controller</b>				
TD	Transmit Data	Output		
RD	Receive Data	Input		
TK	Transmit Clock	I/O		
RK	Receive Clock	I/O		
TF	Transmit Frame Sync	I/O		
RF	Receive Frame Sync	I/O		
<b>Timer/Counter</b>				
TCLK0 - TCLK2	External Clock Inputs	Input		
TIOA0 - TIOA2	I/O Line A	I/O		
TIOB0 - TIOB2	I/O Line B	I/O		
<b>PWM Controller</b>				
PWM0 - PWM3	PWM Channels	Output		
<b>Serial Peripheral Interface - SPIx</b>				
SPIx_MISO	Master In Slave Out	I/O		
SPIx_MOSI	Master Out Slave In	I/O		
SPIx_SPCK	SPI Serial Clock	I/O		
SPIx_NPCS0	SPI Peripheral Chip Select 0	I/O	Low	
SPIx_NPCS1-NPCS3	SPI Peripheral Chip Select 1 to 3	Output	Low	
<b>Two-wire Interface</b>				
TWD	Two-wire Serial Data	I/O		
TWCK	Two-wire Serial Clock	I/O		

**Table 3-1.** Signal Description List (Continued)

Signal Name	Function	Type	Active Level	Comments
<b>Analog-to-Digital Converter</b>				
AD0-AD3	Analog Inputs	Analog		Digital pulled-up inputs at reset.
AD4-AD7	Analog Inputs	Analog		Analog Inputs
ADTRG	ADC Trigger	Input		
ADVREF	ADC Reference	Analog		
<b>Fast Flash Programming Interface</b>				
PGMEN0-PGMEN1	Programming Enabling	Input		
PGMM0-PGMM3	Programming Mode	Input		
PGMD0-PGMD15	Programming Data	I/O		
PGMRDY	Programming Ready	Output	High	
PGMNVALID	Data Direction	Output	Low	
PGMNOE	Programming Read	Input	Low	
PGMCK	Programming Clock	Input		
PGMNCMD	Programming Command	Input	Low	
<b>CAN Controller</b>				
CANRX	CAN Input	Input		
CANTX	CAN Output	Output		
<b>Ethernet MAC 10/100</b>				
EREFCK	Reference Clock	Input		RMII only
ETXCK	Transmit Clock	Input		MII only
ERXCK	Receive Clock	Input		MII only
ETXEN	Transmit Enable	Output		
ETX0 - ETX3	Transmit Data	Output		ETX0 - ETX1 only in RMII
ETXER	Transmit Coding Error	Output		MII only
ERXDV	Receive Data Valid	Input		MII only
ECRSDV	Carrier Sense and Data Valid	Input		RMII only
ERX0 - ERX3	Receive Data	Input		ERX0 - ERX1 only in RMII
ERXER	Receive Error	Input		
ECRS	Carrier Sense	Input		MII only
ECOL	Collision Detected	Input		MII only
EMDC	Management Data Clock	Output		
EMDIO	Management Data Input/Output	I/O		
EF100	Force 100 Mbits/sec.	Output	High	RMII only

Note: 1. Refer to [Section 6. "I/O Lines Considerations"](#).

## 4. Package

The AT91SAM7XC512/256/128 is available in 100-lead LQFP Green and 100-ball TFBGA RoHS-compliant packages.

### 4.1 100-lead LQFP Package Outline

Figure 4-1 shows the orientation of the 100-lead LQFP package. A detailed mechanical description is given in the Mechanical Characteristics section of the full datasheet.

Figure 4-1. 100-lead LQFP Package Outline (Top View)

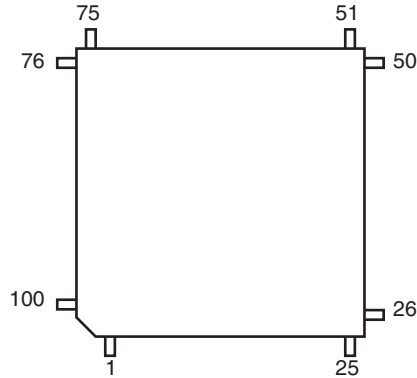

## 4.2 100-lead LQFP Pinout

Table 4-1. Pinout in 100-lead LQFP Package

1	ADVREF	26	PA18/PGMD6	51	TDI	76	TDO
2	GND	27	PB9	52	GND	77	JTAGSEL
3	AD4	28	PB8	53	PB16	78	TMS
4	AD5	29	PB14	54	PB4	79	TCK
5	AD6	30	PB13	55	PA23/PGMD11	80	PA30
6	AD7	31	PB6	56	PA24/PGMD12	81	PA0/PGMENO
7	VDDOUT	32	GND	57	NRST	82	PA1/PGMEN1
8	VDDIN	33	VDDIO	58	TST	83	GND
9	PB27/AD0	34	PB5	59	PA25/PGMD13	84	VDDIO
10	PB28/AD1	35	PB15	60	PA26/PGMD14	85	PA3
11	PB29/AD2	36	PB17	61	VDDIO	86	PA2
12	PB30/AD3	37	VDDCORE	62	VDDCORE	87	VDDCORE
13	PA8/PGMM0	38	PB7	63	PB18	88	PA4/PGMNCMD
14	PA9/PGMM1	39	PB12	64	PB19	89	PA5/PGMRDY
15	VDDCORE	40	PB0	65	PB20	90	PA6/PGMNOE
16	GND	41	PB1	66	PB21	91	PA7/PGMINVALID
17	VDDIO	42	PB2	67	PB22	92	ERASE
18	PA10/PGMM2	43	PB3	68	GND	93	DDM
19	PA11/PGMM3	44	PB10	69	PB23	94	DDP
20	PA12/PGMD0	45	PB11	70	PB24	95	VDDFLASH
21	PA13/PGMD1	46	PA19/PGMD7	71	PB25	96	GND
22	PA14/PGMD2	47	PA20/PGMD8	72	PB26	97	XIN/PGMCK
23	PA15/PGMD3	48	VDDIO	73	PA27/PGMD15	98	XOUT
24	PA16/PGMD4	49	PA21/PGMD9	74	PA28	99	PLLRC
25	PA17/PGMD5	50	PA22/PGMD10	75	PA29	100	VDDPLL

## 4.3 100-ball TFBGA Package Outline

Figure 4-2 shows the orientation of the 100-ball TFBGA package. A detailed mechanical description is given in the Mechanical Characteristics section of the full datasheet.

Figure 4-2. 100-ball TFBGA Package Orientation (Top View)

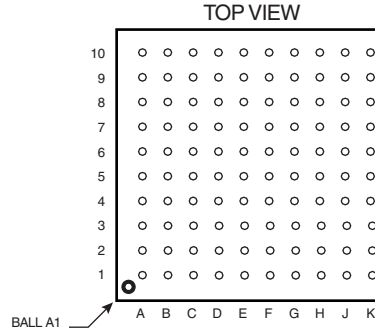

## 4.4 100-ball TFBGA Pinout

Table 4-2. Pinout in 100-ball TFBGA Package

Pin	Signal Name	Pin	Signal Name	Pin	Signal Name	Pin	Signal Name
A1	PA22/PGMD10	C6	PB17	F1	PB21	H6	PA7/PGMINVALID
A2	PA21/PGMD9	C7	PB13	F2	PB23	H7	PA9/PGMM1
A3	PA20/PGMD8	C8	PA13/PGMD1	F3	PB25	H8	PA8/PGMM0
A4	PB1	C9	PA12/PGMD0	F4	PB26	H9	PB29/AD2
A5	PB7	C10	PA15/PGMD3	F5	TCK	H10	PLLRC
A6	PB5	D1	PA23/PGMD11	F6	PA6/PGMNOE	J1	PA29
A7	PB8	D2	PA24/PGMD12	F7	ERASE	J2	PA30
A8	PB9	D3	NRST	F8	VDDCORE	J3	PA0/PGMEN0
A9	PA18/PGMD6	D4	TST	F9	GND	J4	PA1/PGMEN1
A10	VDDIO	D5	PB19	F10	VDDIN	J5	VDDFLASH
B1	TDI	D6	PB6	G1	PB22	J6	GND
B2	PA19/PGMD7	D7	PA10/PGMM2	G2	PB24	J7	XIN/PGMCK
B3	PB11	D8	VDDIO	G3	PA27/PGMD15	J8	XOUT
B4	PB2	D9	PB27/AD0	G4	TDO	J9	GND
B5	PB12	D10	PA11/PGMM3	G5	PA2	J10	VDDPLL
B6	PB15	E1	PA25/PGMD13	G6	PA5/PGMRDY	K1	VDDCORE
B7	PB14	E2	PA26/PGMD14	G7	VDDCORE	K2	VDDCORE
B8	PA14/PGMD2	E3	PB18	G8	GND	K3	DDP
B9	PA16/PGMD4	E4	PB20	G9	PB30/AD3	K4	DDM
B10	PA17/PGMD5	E5	TMS	G10	VDDOUT	K5	GND
C1	PB16	E6	GND	H1	VDDCORE	K6	AD7
C2	PB4	E7	VDDIO	H2	PA28	K7	AD6
C3	PB10	E8	PB28/AD1	H3	JTAGSEL	K8	AD5
C4	PB3	E9	VDDIO	H4	PA3	K9	AD4
C5	PB0	E10	GND	H5	PA4/PGMNCMD	K10	ADVREF

## 5. Power Considerations

### 5.1 Power Supplies

The AT91SAM7XC512/256/128 has six types of power supply pins and integrates a voltage regulator, allowing the device to be supplied with only one voltage. The six power supply pin types are:

- VDDIN pin. It powers the voltage regulator and the ADC; voltage ranges from 3.0V to 3.6V, 3.3V nominal. In order to decrease current consumption, if the voltage regulator and the ADC are not used, VDDIN, ADVREF, AD4, AD5, AD6 and AD7 should be connected to GND. In this case, VDDOUT should be left unconnected.
- VDDOUT pin. It is the output of the 1.8V voltage regulator.
- VDDIO pin. It powers the I/O lines; voltage ranges from 3.0V to 3.6V, 3.3V nominal.
- VDDFLASH pin. It powers the USB transceivers and a part of the Flash and is required for the Flash to operate correctly; voltage ranges from 3.0V to 3.6V, 3.3V nominal.
- VDDCORE pins. They power the logic of the device; voltage ranges from 1.65V to 1.95V, 1.8V typical. It can be connected to the VDDOUT pin with decoupling capacitor. VDDCORE is required for the device, including its embedded Flash, to operate correctly.
- VDDPLL pin. It powers the oscillator and the PLL. It can be connected directly to the VDDOUT pin.

No separate ground pins are provided for the different power supplies. Only GND pins are provided and should be connected as shortly as possible to the system ground plane.

### 5.2 Power Consumption

The AT91SAM7XC512/256/128 has a static current of less than 60  $\mu\text{A}$  on VDDCORE at 25°C, including the RC oscillator, the voltage regulator and the power-on reset when the brownout detector is deactivated. Activating the brownout detector adds 28  $\mu\text{A}$  static current.

The dynamic power consumption on VDDCORE is less than 90 mA at full speed when running out of the Flash. Under the same conditions, the power consumption on VDDFLASH does not exceed 10 mA.

### 5.3 Voltage Regulator

The AT91SAM7XC512/256/128 embeds a voltage regulator that is managed by the System Controller.

In Normal Mode, the voltage regulator consumes less than 100  $\mu\text{A}$  static current and draws 100 mA of output current.

The voltage regulator also has a Low-power Mode. In this mode, it consumes less than 25  $\mu\text{A}$  static current and draws 1 mA of output current.

Adequate output supply decoupling is mandatory for VDDOUT to reduce ripple and avoid oscillations. The best way to achieve this is to use two capacitors in parallel: one external 470 pF (or 1 nF) NPO capacitor should be connected between VDDOUT and GND as close to the chip as possible. One external 2.2  $\mu\text{F}$  (or 3.3  $\mu\text{F}$ ) X7R capacitor should be connected between VDDOUT and GND.

Adequate input supply decoupling is mandatory for VDDIN in order to improve startup stability and reduce source voltage drop. The input decoupling capacitor should be placed close to the chip. For example, two capacitors can be used in parallel: 100 nF NPO and 4.7  $\mu$ F X7R.

## 5.4 Typical Powering Schematics

The AT91SAM7XC512/256/128 supports a 3.3V single supply mode. The internal regulator input connected to the 3.3V source and its output feeds VDDCORE and the VDDPLL. [Figure 5-1](#) shows the power schematics to be used for USB bus-powered systems.

**Figure 5-1.** 3.3V System Single Power Supply Schematic

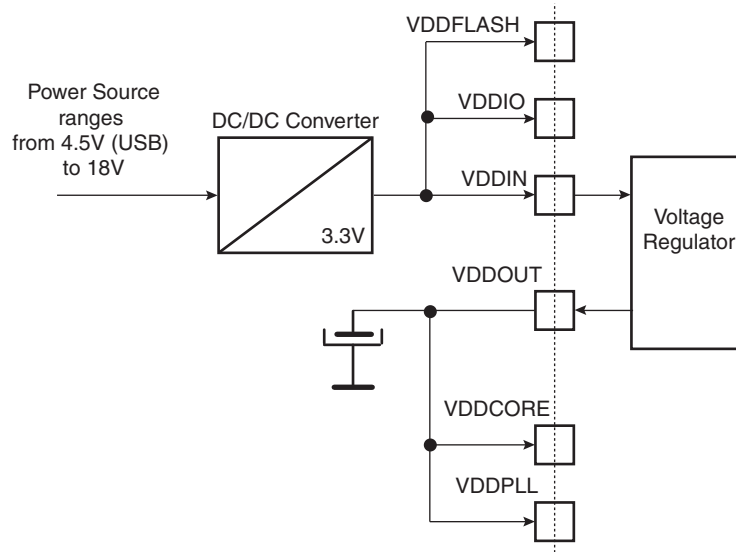

## 6. I/O Lines Considerations

### 6.1 JTAG Port Pins

TMS, TDI and TCK are schmitt trigger inputs and are not 5-V tolerant. TMS, TDI and TCK do not integrate a pull-up resistor.

TDO is an output, driven at up to VDDIO, and has no pull-up resistor.

The JTAGSEL pin is used to select the JTAG boundary scan when asserted at a high level. The JTAGSEL pin integrates a permanent pull-down resistor of about 15 k $\Omega$ .

To eliminate any risk of spuriously entering the JTAG boundary scan mode due to noise on JTAGSEL, it should be tied externally to GND if boundary scan is not used, or pulled down with an external low-value resistor (such as 1 k $\Omega$ ).

### 6.2 Test Pin

The TST pin is used for manufacturing test or fast programming mode of the AT91SAM7XC512/256/128 when asserted high. The TST pin integrates a permanent pull-down resistor of about 15 k $\Omega$  to GND.

To eliminate any risk of entering the test mode due to noise on the TST pin, it should be tied to GND if the FFPI is not used, or pulled down with an external low-value resistor (such as 1 k $\Omega$ ).

To enter fast programming mode, the TST pin and the PA0 and PA1 pins should be tied high and PA2 tied to low.

Driving the TST pin at a high level while PA0 or PA1 is driven at 0 leads to unpredictable results.

### 6.3 Reset Pin

The NRST pin is bidirectional with an open drain output buffer. It is handled by the on-chip reset controller and can be driven low to provide a reset signal to the external components or asserted low externally to reset the microcontroller. There is no constraint on the length of the reset pulse, and the reset controller can guarantee a minimum pulse length. This allows connection of a simple push-button on the NRST pin as system user reset, and the use of the signal NRST to reset all the components of the system.

The NRST pin integrates a permanent pull-up resistor to VDDIO.

### 6.4 ERASE Pin

The ERASE pin is used to re-initialize the Flash content and some of its NVM bits. It integrates a permanent pull-down resistor of about 15 k $\Omega$  to GND.

To eliminate any risk of erasing the Flash due to noise on the ERASE pin, it should be tied externally to GND, which prevents erasing the Flash from the application, or pulled down with an external low-value resistor (such as 1 k $\Omega$ ).

This pin is debounced by the RC oscillator to improve the glitch tolerance. Minimum debouncing time is 200 ms.

### 6.5 PIO Controller Lines

All the I/O lines, PA0 to PA30 and PB0 to PB30, are 5V-tolerant and all integrate a programmable pull-up resistor. Programming of this pull-up resistor is performed independently for each I/O line through the PIO controllers.

5V-tolerant means that the I/O lines can drive voltage level according to VDDIO, but can be driven with a voltage of up to 5.5V. However, driving an I/O line with a voltage over VDDIO while the programmable pull-up resistor is enabled will create a current path through the pull-up resistor from the I/O line to VDDIO. Care should be taken, in particular at reset, as all the I/O lines default to input with pull-up resistor enabled at reset.

## **6.6 I/O Lines Current Drawing**

The PIO lines PA0 to PA3 are high-drive current capable. Each of these I/O lines can drive up to 16 mA permanently.

The remaining I/O lines can draw only 8 mA.

However, the total current drawn by all the I/O lines cannot exceed 200 mA.

## 7. Processor and Architecture

### 7.1 ARM7TDMI Processor

- RISC processor based on ARMv4T Von Neumann architecture
  - Runs at up to 55 MHz, providing 0.9 MIPS/MHz
- Two instruction sets
  - ARM<sup>®</sup> high-performance 32-bit instruction set
  - Thumb<sup>®</sup> high code density 16-bit instruction set
- Three-stage pipeline architecture
  - Instruction Fetch (F)
  - Instruction Decode (D)
  - Execute (E)

### 7.2 Debug and Test Features

- Integrated embedded in-circuit emulator
  - Two watchpoint units
  - Test access port accessible through a JTAG protocol
  - Debug communication channel
- Debug Unit
  - Two-pin UART
  - Debug communication channel interrupt handling
  - Chip ID Register
- IEEE1149.1 JTAG Boundary-scan on all digital pins

### 7.3 Memory Controller

- Programmable Bus Arbiter
  - Handles requests from the ARM7TDMI, the Ethernet MAC and the Peripheral DMA Controller
- Address decoder provides selection signals for
  - Three internal 1 Mbyte memory areas
  - One 256 Mbyte embedded peripheral area
- Abort Status Registers
  - Source, Type and all parameters of the access leading to an abort are saved
  - Facilitates debug by detection of bad pointers
- Misalignment Detector
  - Alignment checking of all data accesses
  - Abort generation in case of misalignment
- Remap Command
  - Remaps the SRAM in place of the embedded non-volatile memory
  - Allows handling of dynamic exception vectors

- Embedded Flash Controller
  - Embedded Flash interface, up to three programmable wait states
  - Prefetch buffer, buffering and anticipating the 16-bit requests, reducing the required wait states
  - Key-protected program, erase and lock/unlock sequencer
  - Single command for erasing, programming and locking operations
  - Interrupt generation in case of forbidden operation

## **7.4 Peripheral DMA Controller**

- Handles data transfer between peripherals and memories
- Seventeen channels
  - Two for each USART
  - Two for the Debug Unit
  - Two for the Serial Synchronous Controller
  - Two for each Serial Peripheral Interface
  - Two for the Advanced Encryption Standard 128-bit accelerator
  - Two for the Triple Data Encryption Standard 128-bit accelerator
  - One for the Analog-to-digital Converter
- Low bus arbitration overhead
  - One Master Clock cycle needed for a transfer from memory to peripheral
  - Two Master Clock cycles needed for a transfer from peripheral to memory
- Next Pointer management for reducing interrupt latency requirements

## 8. Memory

### 8.1 AT91SAM7XC512

- 512 Kbytes of dual-plane Flash Memory
  - 2 contiguous banks of 1024 pages of 256 bytes
  - Fast access time, 30 MHz single-cycle access in Worst Case conditions
  - Page programming time: 6 ms, including page auto-erase
  - Page programming without auto-erase: 3 ms
  - Full chip erase time: 15 ms
  - 10,000 write cycles, 10-year data retention capability
  - 32 lock bits, protecting 32 sectors of 64 pages
  - Protection Mode to secure contents of the Flash
- 128 Kbytes of Fast SRAM
  - Single-cycle access at full speed

### 8.2 AT91SAM7XC256

- 256 Kbytes of Flash Memory
  - 1024 pages of 256 bytes
  - Fast access time, 30 MHz single-cycle access in Worst Case conditions
  - Page programming time: 6 ms, including page auto-erase
  - Page programming without auto-erase: 3 ms
  - Full chip erase time: 15 ms
  - 10,000 write cycles, 10-year data retention capability
  - 16 lock bits, each protecting 16 sectors of 64 pages
  - Protection Mode to secure contents of the Flash
- 64 Kbytes of Fast SRAM
  - Single-cycle access at full speed

### 8.3 AT91SAM7XC128

- 128 Kbytes of Flash Memory
  - 512 pages of 256 bytes
  - Fast access time, 30 MHz single-cycle access in Worst Case conditions
  - Page programming time: 6 ms, including page auto-erase
  - Page programming without auto-erase: 3 ms
  - Full chip erase time: 15 ms
  - 10,000 write cycles, 10-year data retention capability
  - 8 lock bits, each protecting 8 sectors of 64 pages
  - Protection Mode to secure contents of the Flash
- 32 Kbytes of Fast SRAM
  - Single-cycle access at full speed

**Figure 8-1. AT91SAM7XC512/256/128 Memory Mapping**

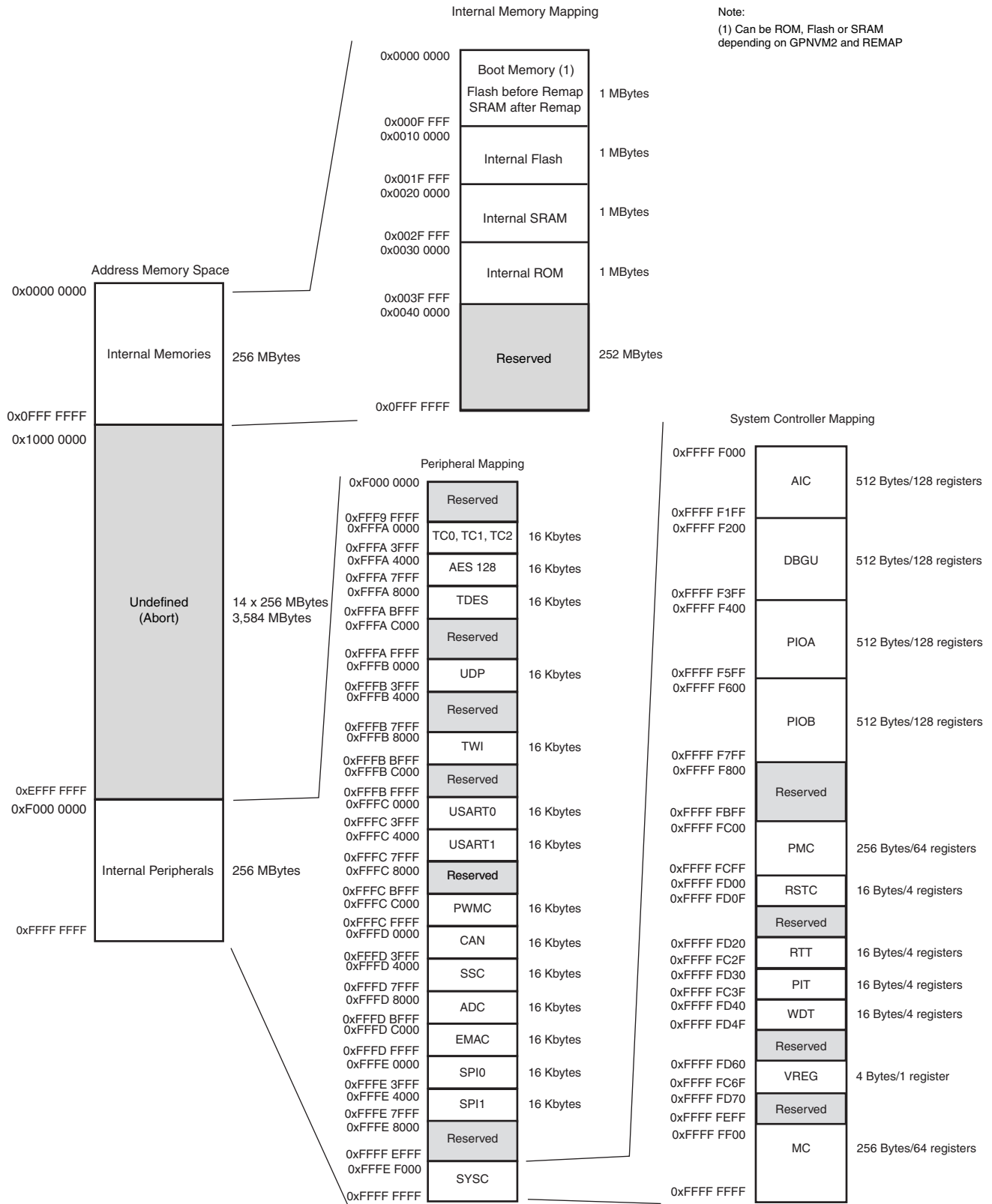

## 8.4 Memory Mapping

### 8.4.1 Internal RAM

- The AT91SAM7XC512 embeds a high-speed 128-Kbyte SRAM bank.
- The AT91SAM7XC256 embeds a high-speed 64-Kbyte SRAM bank.
- The AT91SAM7XC128 embeds a high-speed 32-Kbyte SRAM bank.

After reset and until the Remap Command is performed, the SRAM is only accessible at address 0x0020 0000. After Remap, the SRAM also becomes available at address 0x0.

### 8.4.2 Internal ROM

The AT91SAM7XC512/256/128 embeds an Internal ROM. At any time, the ROM is mapped at address 0x30 0000. The ROM contains the FFPI and the SAM-BA program.

### 8.4.3 Internal Flash

- The AT91SAM7XC512 features two banks (dual plane) of 256 Kbytes of Flash.
- The AT91SAM7XC256 features one bank (single plane) of 256 Kbytes of Flash.
- The AT91SAM7XC128 features one bank (single plane) of 128 Kbytes of Flash.

At any time, the Flash is mapped to address 0x0010 0000. It is also accessible at address 0x0 after the reset, if GPNVM bit 2 is set and before the Remap Command.

A general purpose NVM (GPNVM) bit is used to boot either on the ROM (default) or from the Flash.

This GPNVM bit can be cleared or set respectively through the commands “Clear General-purpose NVM Bit” and “Set General-purpose NVM Bit” of the EFC User Interface.

Setting the GPNVM Bit 2 selects the boot from the Flash. Asserting ERASE clears the GPNVM Bit 2 and thus selects the boot from the ROM by default.

**Figure 8-2.** Internal Memory Mapping with GPNVM Bit 2 = 0 (default)

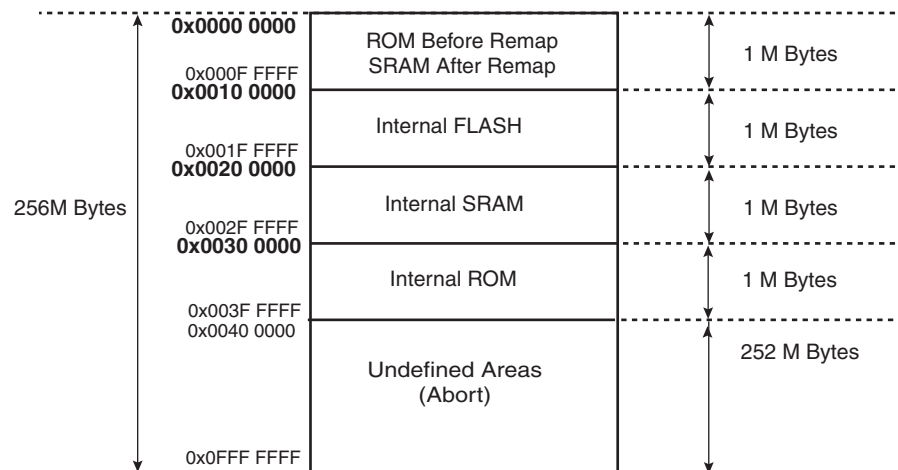

**Figure 8-3.** Internal Memory Mapping with GPNVM Bit 2 = 1

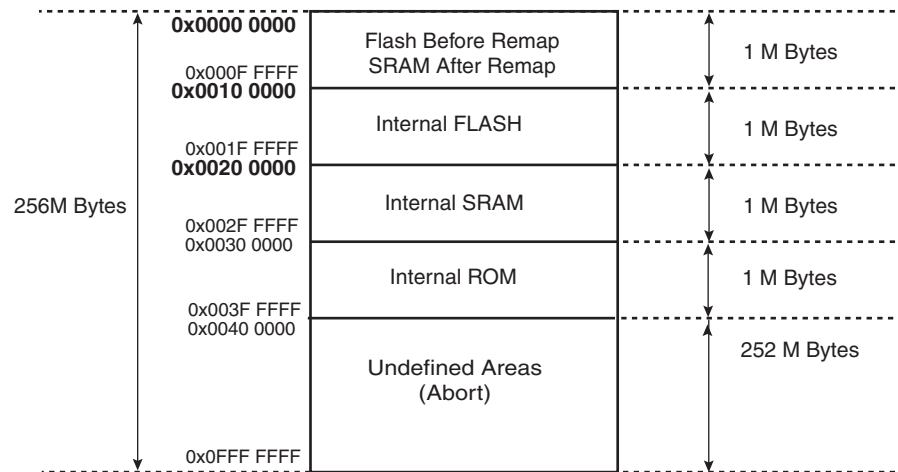

## 8.5 Embedded Flash

### 8.5.1 Flash Overview

- The Flash of the AT91SAM7XC512 is organized in two banks (dual plane) Of 1254 pages of 256 bytes. The 524, 288 bytes are organized in 32-bit words.
- The Flash of the AT91SAM7XC256 is organized in 1024 pages of 256 bytes (single plane). It reads as 65,536 32-bit words.
- The Flash of the AT91SAM7XC128 is organized in 512 pages of 256 bytes (single plane). It reads as 32,768 32-bit words.

The Flash contains a 256-byte write buffer, accessible through a 32-bit interface.

The Flash benefits from the integration of a power reset cell and from the brownout detector. This prevents code corruption during power supply changes, even in the worst conditions.

When Flash is not used (read or write access), it is automatically placed into standby mode.

### 8.5.2 Embedded Flash Controller

The Embedded Flash Controller (EFC) manages accesses performed by the masters of the system. It enables reading the Flash and writing the write buffer. It also contains a User Interface, mapped within the Memory Controller on the APB. The User Interface allows:

- programming of the access parameters of the Flash (number of wait states, timings, etc.)
- starting commands such as full erase, page erase, page program, NVM bit set, NVM bit clear, etc.
- getting the end status of the last command
- getting error status
- programming interrupts on the end of the last commands or on errors

The Embedded Flash Controller also provides a dual 32-bit Prefetch Buffer that optimizes 16-bit access to the Flash. This is particularly efficient when the processor is running in Thumb mode.

Two EFCs are embedded in the AT91SAM7XC512 to control each bank of 256 KBytes. Dual-plane organization allows concurrent read and program functionality. Read from one memory

plane may be performed even while program or erase functions are being executed in the other memory plane.

One EFC is embedded in the AT91SAM7XC256/128 to control the single plane of 256/128 KBytes.

### 8.5.3 Lock Regions

#### 8.5.3.1 AT91SAM7XC512

Two Embedded Flash Controllers each manage 16 lock bits to protect 16 regions of the flash against inadvertent flash erasing or programming commands. The AT91SAM7XC512 contains 32 lock regions and each lock region contains 64 pages of 256 bytes. Each lock region has a size of 16 Kbytes.

If a locked-region's erase or program command occurs, the command is aborted and the EFC trigs an interrupt.

The 32 NVM bits are software programmable through both of the EFC User Interfaces. The command "Set Lock Bit" enables the protection. The command "Clear Lock Bit" unlocks the lock region.

Asserting the ERASE pin clears the lock bits, thus unlocking the entire Flash.

#### 8.5.3.2 AT91SAM7XC256

The Embedded Flash Controller manages 16 lock bits to protect 16 regions of the flash against inadvertent flash erasing or programming commands. The AT91SAM7XC256 contains 16 lock regions and each lock region contains 64 pages of 256 bytes. Each lock region has a size of 16 Kbytes.

If a locked-region's erase or program command occurs, the command is aborted and the EFC trigs an interrupt.

The 16 NVM bits are software programmable through the EFC User Interface. The command "Set Lock Bit" enables the protection. The command "Clear Lock Bit" unlocks the lock region.

Asserting the ERASE pin clears the lock bits, thus unlocking the entire Flash.

#### 8.5.3.3 AT91SAM7XC128

The Embedded Flash Controller manages 8 lock bits to protect 8 regions of the flash against inadvertent flash erasing or programming commands. The AT91SAM7XC128 contains 8 lock regions and each lock region contains 64 pages of 256 bytes. Each lock region has a size of 16 Kbytes.

If a locked-region's erase or program command occurs, the command is aborted and the EFC trigs an interrupt.

The 8 NVM bits are software programmable through the EFC User Interface. The command "Set Lock Bit" enables the protection. The command "Clear Lock Bit" unlocks the lock region.

Asserting the ERASE pin clears the lock bits, thus unlocking the entire Flash.

### 8.5.4 Security Bit Feature

The AT91SAM7XC512/256/128 features a security bit, based on a specific NVM-Bit. When the security is enabled, any access to the Flash, either through the ICE interface or through the Fast

Flash Programming Interface, is forbidden. This ensures the confidentiality of the code programmed in the Flash.

This security bit can only be enabled, through the Command “Set Security Bit” of the EFC User Interface. Disabling the security bit can only be achieved by asserting the ERASE pin at 1, and after a full flash erase is performed. When the security bit is deactivated, all accesses to the flash are permitted.

It is important to note that the assertion of the ERASE pin should always be longer than 220 ms.

As the ERASE pin integrates a permanent pull-down, it can be left unconnected during normal operation. However, it is safer to connect it directly to GND for the final application.

### **8.5.5 Non-volatile Brownout Detector Control**

Two general purpose NVM (GPNVM) bits are used for controlling the brownout detector (BOD), so that even after a power loss, the brownout detector operations remain in their state.

These two GPNVM bits can be cleared or set respectively through the commands “Clear General-purpose NVM Bit” and “Set General-purpose NVM Bit” of the EFC User Interface.

- GPNVM Bit 0 is used as a brownout detector enable bit. Setting the GPNVM Bit 0 enables the BOD, clearing it disables the BOD. Asserting ERASE clears the GPNVM Bit 0 and thus disables the brownout detector by default.
- The GPNVM Bit 1 is used as a brownout reset enable signal for the reset controller. Setting the GPNVM Bit 1 enables the brownout reset when a brownout is detected, Clearing the GPNVM Bit 1 disables the brownout reset. Asserting ERASE disables the brownout reset by default.

### **8.5.6 Calibration Bits**

Eight NVM bits are used to calibrate the brownout detector and the voltage regulator. These bits are factory configured and cannot be changed by the user. The ERASE pin has no effect on the calibration bits.

## **8.6 Fast Flash Programming Interface**

The Fast Flash Programming Interface allows programming the device through either a serial JTAG interface or through a multiplexed fully-handshaked parallel port. It allows gang-programming with market-standard industrial programmers.

The FFPI supports read, page program, page erase, full erase, lock, unlock and protect commands.

The Fast Flash Programming Interface is enabled and the Fast Programming Mode is entered when the TST pin and the PA0 and PA1 pins are all tied high.

## **8.7 SAM-BA Boot Assistant**

The SAM-BA Boot Assistant is a default Boot Program that provides an easy way to program in-situ the on-chip Flash memory.

The SAM-BA Boot Assistant supports serial communication via the DBGU or the USB Device Port.

- Communication via the DBGU supports a wide range of crystals from 3 to 20 MHz via software auto-detection.



- Communication via the USB Device Port is limited to an 18.432 MHz crystal.
- The SAM-BA Boot provides an interface with SAM-BA Graphic User Interface (GUI).  
The SAM-BA Boot is in ROM and is mapped at address 0x0 when the GPNVM Bit 2 is set to 0.  
When GPNVM bit 2 is set to 1, the device boots from the Flash.  
When GPNVM bit 2 is set to 0, the device boots from ROM (SAM-BA).

## 9. System Controller

The System Controller manages all vital blocks of the microcontroller: interrupts, clocks, power, time, debug and reset.

The System Controller peripherals are all mapped to the highest 4 Kbytes of address space, between addresses 0xFFFF F000 and 0xFFFF FFFF.

[Figure 9-1 on page 26](#) shows the System Controller Block Diagram.

[Figure 8-1 on page 19](#) shows the mapping of the User Interface of the System Controller peripherals. Note that the Memory Controller configuration user interface is also mapped within this address space.

**Figure 9-1. System Controller Block Diagram**

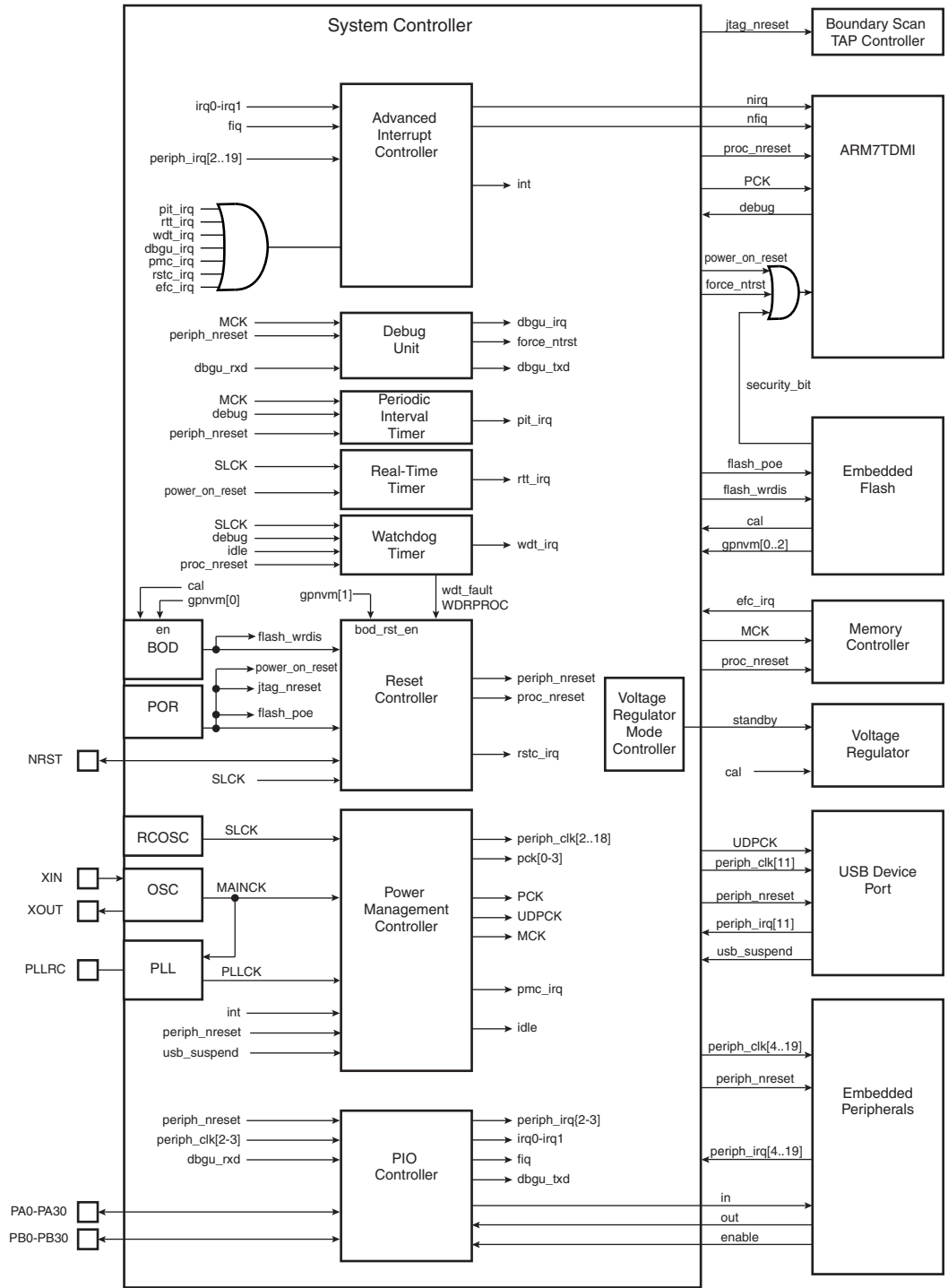

## 9.1 Reset Controller

- Based on one power-on reset cell and one brownout detector
- Status of the last reset, either Power-up Reset, Software Reset, User Reset, Watchdog Reset, Brownout Reset
- Controls the internal resets and the NRST pin output
- Allows to shape a signal on the NRST line, guaranteeing that the length of the pulse meets any requirement.

### 9.1.1 Brownout Detector and Power-on Reset

The AT91SAM7XC512/256/128 embeds one brownout detection circuit and a power-on reset cell. The power-on reset is supplied with and monitors VDDCORE.

Both signals are provided to the Flash to prevent any code corruption during power-up or power-down sequences or if brownouts occur on the power supplies.

The power-on reset cell has a limited-accuracy threshold at around 1.5V. Its output remains low during power-up until VDDCORE goes over this voltage level. This signal goes to the reset controller and allows a full re-initialization of the device.

The brownout detector monitors the VDDCORE and VDDFLASH levels during operation by comparing them to a fixed trigger level. It secures system operations in the most difficult environments and prevents code corruption in case of brownout on the VDDCORE or VDDFLASH.

When the brownout detector is enabled and VDDCORE decreases to a value below the trigger level ( $V_{bot18-}$ , defined as  $V_{bot18} - hyst/2$ ), the brownout output is immediately activated.

When VDDCORE increases above the trigger level ( $V_{bot18+}$ , defined as  $V_{bot18} + hyst/2$ ), the reset is released. The brownout detector only detects a drop if the voltage on VDDCORE stays below the threshold voltage for longer than about 1 $\mu$ s.

The VDDCORE threshold voltage has a hysteresis of about 50 mV, to ensure spike free brownout detection. The typical value of the brownout detector threshold is 1.68V with an accuracy of  $\pm 2\%$  and is factory calibrated.

When the brownout detector is enabled and VDDFLASH decreases to a value below the trigger level ( $V_{bot33-}$ , defined as  $V_{bot33} - hyst/2$ ), the brownout output is immediately activated.

When VDDFLASH increases above the trigger level ( $V_{bot33+}$ , defined as  $V_{bot33} + hyst/2$ ), the reset is released. The brownout detector only detects a drop if the voltage on VDDCORE stays below the threshold voltage for longer than about 1 $\mu$ s.

The VDDFLASH threshold voltage has a hysteresis of about 50 mV, to ensure spike free brownout detection. The typical value of the brownout detector threshold is 2.80V with an accuracy of  $\pm 3.5\%$  and is factory calibrated.

The brownout detector is low-power, as it consumes less than 28  $\mu$ A static current. However, it can be deactivated to save its static current. In this case, it consumes less than 1 $\mu$ A. The deactivation is configured through the GPNVM bit 0 of the Flash.

## 9.2 Clock Generator

The Clock Generator embeds one low-power RC Oscillator, one Main Oscillator and one PLL with the following characteristics:

- RC Oscillator ranges between 22 KHz and 42 KHz
- Main Oscillator frequency ranges between 3 and 20 MHz
- Main Oscillator can be bypassed
- PLL output ranges between 80 and 200 MHz

It provides SLCK, MAINCK and PLLCK.

**Figure 9-2.** Clock Generator Block Diagram

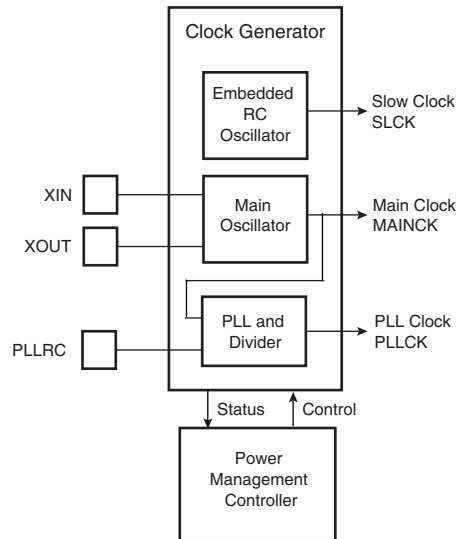

## 9.3 Power Management Controller

The Power Management Controller uses the Clock Generator outputs to provide:

- the Processor Clock PCK
- the Master Clock MCK
- the USB Clock UDPCCK
- all the peripheral clocks, independently controllable
- four programmable clock outputs

The Master Clock (MCK) is programmable from a few hundred Hz to the maximum operating frequency of the device.

The Processor Clock (PCK) switches off when entering processor idle mode, thus allowing reduced power consumption while waiting for an interrupt.

**Figure 9-3.** Power Management Controller Block Diagram

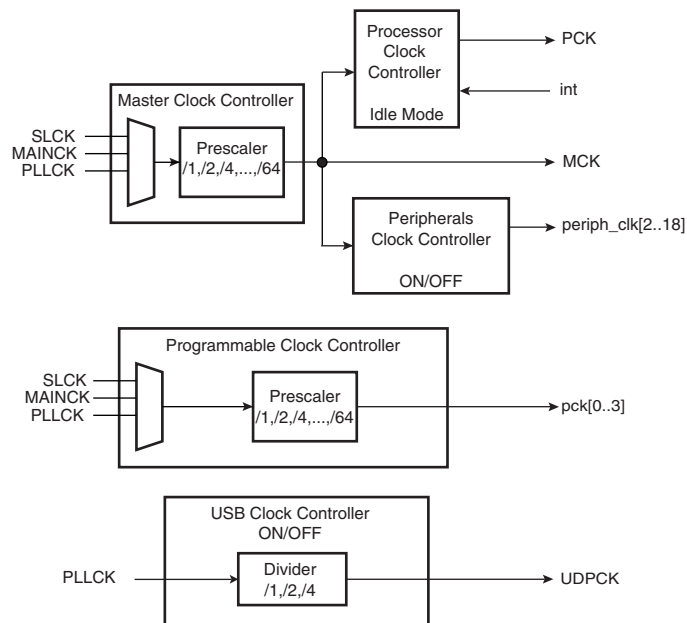

## 9.4 Advanced Interrupt Controller

- Controls the interrupt lines (nIRQ and nFIQ) of an ARM Processor
- Individually maskable and vectored interrupt sources
  - Source 0 is reserved for the Fast Interrupt Input (FIQ)
  - Source 1 is reserved for system peripherals (RTT, PIT, EFC, PMC, DBGU, etc.)
  - Other sources control the peripheral interrupts or external interrupts
  - Programmable edge-triggered or level-sensitive internal sources
  - Programmable positive/negative edge-triggered or high/low level-sensitive external sources
- 8-level Priority Controller
  - Drives the normal interrupt nIRQ of the processor
  - Handles priority of the interrupt sources

- Higher priority interrupts can be served during service of lower priority interrupt
- Vectoring
  - Optimizes interrupt service routine branch and execution
  - One 32-bit vector register per interrupt source
  - Interrupt vector register reads the corresponding current interrupt vector
- Protect Mode
  - Easy debugging by preventing automatic operations
- Fast Forcing
  - Permits redirecting any interrupt source on the fast interrupt
- General Interrupt Mask
  - Provides processor synchronization on events without triggering an interrupt

## 9.5 Debug Unit

- Comprises:
  - One two-pin UART
  - One Interface for the Debug Communication Channel (DCC) support
  - One set of Chip ID Registers
  - One Interface providing ICE Access Prevention
- Two-pin UART
  - USART-compatible User Interface
  - Programmable Baud Rate Generator
  - Parity, Framing and Overrun Error
  - Automatic Echo, Local Loopback and Remote Loopback Channel Modes
- Debug Communication Channel Support
  - Offers visibility of COMMRX and COMMTX signals from the ARM Processor
- Chip ID Registers
  - Identification of the device revision, sizes of the embedded memories, set of peripherals
  - Chip ID is 0x271C 0A40 (VERSION 0) for AT91SAM7XC512
  - Chip ID is 0x271B 0940 (VERSION 0) for AT91SAM7XC256
  - Chip ID is 0x271A 0740 (VERSION 0) for AT91SAM7XC128

## 9.6 Periodic Interval Timer

- 20-bit programmable counter plus 12-bit interval counter

## 9.7 Watchdog Timer

- 12-bit key-protected Programmable Counter running on prescaled SLCK
- Provides reset or interrupt signals to the system
- Counter may be stopped while the processor is in debug state or in idle mode

## 9.8 Real-time Timer

- 32-bit free-running counter with alarm running on prescaled SLCK

- Programmable 16-bit prescaler for SLCK accuracy compensation

## **9.9 PIO Controllers**

- Two PIO Controllers, each controlling 31 I/O lines
- Fully programmable through set/clear registers
- Multiplexing of two peripheral functions per I/O line
- For each I/O line (whether assigned to a peripheral or used as general-purpose I/O)
  - Input change interrupt
  - Half a clock period glitch filter
  - Multi-drive option enables driving in open drain
  - Programmable pull-up on each I/O line
  - Pin data status register, supplies visibility of the level on the pin at any time
- Synchronous output, provides Set and Clear of several I/O lines in a single write

## **9.10 Voltage Regulator Controller**

The purpose of this controller is to select the Power Mode of the Voltage Regulator between Normal Mode (bit 0 is cleared) or Standby Mode (bit 0 is set).

## 10. Peripherals

### 10.1 User Interface

The User Peripherals are mapped in the 256 MBytes of address space between 0xF000 0000 and 0xFFFFE FFFF. Each peripheral is allocated 16 Kbytes of address space.

A complete memory map is provided in [Figure 8-1 on page 19](#).

### 10.2 Peripheral Identifiers

The AT91SAM7XC512/256/128 embeds a wide range of peripherals. [Table 10-1](#) defines the Peripheral Identifiers of the AT91SAM7XC512/256/128. Unique peripheral identifiers are defined for both the Advanced Interrupt Controller and the Power Management Controller.

**Table 10-1.** Peripheral Identifiers

Peripheral ID	Peripheral Mnemonic	Peripheral Name	External Interrupt
0	AIC	Advanced Interrupt Controller	FIQ
1	SYSC <sup>(1)</sup>	System	
2	PIOA	Parallel I/O Controller A	
3	PIOB	Parallel I/O Controller B	
4	SPIO	Serial Peripheral Interface 0	
5	SPI1	Serial Peripheral Interface 1	
6	US0	USART 0	
7	US1	USART 1	
8	SSC	Synchronous Serial Controller	
9	TWI	Two-wire Interface	
10	PWMC	Pulse Width Modulation Controller	
11	UDP	USB device Port	
12	TC0	Timer/Counter 0	
13	TC1	Timer/Counter 1	
14	TC2	Timer/Counter 2	
15	CAN	CAN Controller	
16	EMAC	Ethernet MAC	
17	ADC <sup>(1)</sup>	Analog-to Digital Converter	
18	AES	Advanced Encryption Standard 128-bit	
19	TDES	Triple Data Encryption Standard	
20-29	Reserved		
30	AIC	Advanced Interrupt Controller	IRQ0
31	AIC	Advanced Interrupt Controller	IRQ1

Note: 1. Setting SYSC and ADC bits in the clock set/clear registers of the PMC has no effect. The System Controller and ADC are continuously clocked.

### 10.3 Peripheral Multiplexing on PIO Lines

The AT91SAM7XC512/256/128 features two PIO controllers, PIOA and PIOB, that multiplex the I/O lines of the peripheral set.

Each PIO Controller controls 31 lines. Each line can be assigned to one of two peripheral functions, A or B. Some of them can also be multiplexed with the analog inputs of the ADC Controller.

[Table 10-2 on page 34](#) and [Table 10-3 on page 35](#) defines how the I/O lines of the peripherals A, B or the analog inputs are multiplexed on the PIO Controller A and PIO Controller B. The two columns “Function” and “Comments” have been inserted for the user’s own comments; they may be used to track how pins are defined in an application.

Note that some peripheral functions that are output only, may be duplicated in the table.

At reset, all I/O lines are automatically configured as input with the programmable pull-up enabled, so that the device is maintained in a static state as soon as a reset is detected.

## 10.4 PIO Controller A Multiplexing

**Table 10-2.** Multiplexing on PIO Controller A

PIO Controller A				Application Usage	
I/O Line	Peripheral A	Peripheral B	Comments	Function	Comments
PA0	RXD0		High-Drive		
PA1	TXD0		High-Drive		
PA2	SCK0	SPI1_NPCS1	High-Drive		
PA3	RTS0	SPI1_NPCS2	High-Drive		
PA4	CTS0	SPI1_NPCS3			
PA5	RXD1				
PA6	TXD1				
PA7	SCK1	SPI0_NPCS1			
PA8	RTS1	SPI0_NPCS2			
PA9	CTS1	SPI0_NPCS3			
PA10	TWD				
PA11	TWCK				
PA12	SPI_NPCS0				
PA13	SPI0_NPCS1	PCK1			
PA14	SPI0_NPCS2	IRQ1			
PA15	SPI0_NPCS3	TCLK2			
PA16	SPI0_MISO				
PA17	SPI0_MOSI				
PA18	SPI0_SPCK				
PA19	CANRX				
PA20	CANTX				
PA21	TF	SPI1_NPCS0			
PA22	TK	SPI1_SPCK			
PA23	TD	SPI1_MOSI			
PA24	RD	SPI1_MISO			
PA25	RK	SPI1_NPCS1			
PA26	RF	SPI1_NPCS2			
PA27	DRXD	PCK3			
PA28	DTXD				
PA29	FIQ	SPI1_NPCS3			
PA30	IRQ0	PCK2			

## 10.5 PIO Controller B Multiplexing

**Table 10-3.** Multiplexing on PIO Controller B

PIO Controller B				Application Usage	
I/O Line	Peripheral A	Peripheral B	Comments	Function	Comments
PB0	ETXCK/EREFCK	PCK0			
PB1	ETXEN				
PB2	ETX0				
PB3	ETX1				
PB4	ECRS				
PB5	ERX0				
PB6	ERX1				
PB7	ERXER				
PB8	EMDC				
PB9	EMDIO				
PB10	ETX2	SPI1_NPCS1			
PB11	ETX3	SPI1_NPCS2			
PB12	ETXER	TCLK0			
PB13	ERX2	SPI0_NPCS1			
PB14	ERX3	SPI0_NPCS2			
PB15	ERXDV/ECRSDV				
PB16	ECOL	SPI1_NPCS3			
PB17	ERXCK	SPI0_NPCS3			
PB18	EF100	ADTRG			
PB19	PWM0	TCLK1			
PB20	PWM1	PCK0			
PB21	PWM2	PCK1			
PB22	PWM3	PCK2			
PB23	TIOA0	DCD1			
PB24	TIOB0	DSR1			
PB25	TIOA1	DTR1			
PB26	TIOB1	RI1			
PB27	TIOA2	PWM0	AD0		
PB28	TIOB2	PWM1	AD1		
PB29	PCK1	PWM2	AD2		
PB30	PCK2	PWM3	AD3		

## 10.6 Ethernet MAC

- DMA Master on Receive and Transmit Channels
- Compatible with IEEE Standard 802.3
- 10 and 100 Mbit/s operation
- Full- and half-duplex operation
- Statistics Counter Registers
- MII/RMII interface to the physical layer
- Interrupt generation to signal receive and transmit completion
- 28-byte transmit FIFO and 28-byte receive FIFO
- Automatic pad and CRC generation on transmitted frames
- Automatic discard of frames received with errors
- Address checking logic supports up to four specific 48-bit addresses
- Support Promiscuous Mode where all valid received frames are copied to memory
- Hash matching of unicast and multicast destination addresses
- Physical layer management through MDIO interface
- Half-duplex flow control by forcing collisions on incoming frames
- Full-duplex flow control with recognition of incoming pause frames
- Support for 802.1Q VLAN tagging with recognition of incoming VLAN and priority tagged frames
- Multiple buffers per receive and transmit frame
- Jumbo frames up to 10240 bytes supported

## 10.7 Serial Peripheral Interface

- Supports communication with external serial devices
  - Four chip selects with external decoder allow communication with up to 15 peripherals
  - Serial memories, such as DataFlash<sup>®</sup> and 3-wire EEPROMs
  - Serial peripherals, such as ADCs, DACs, LCD Controllers, CAN Controllers and Sensors
  - External co-processors
- Master or slave serial peripheral bus interface
  - 8- to 16-bit programmable data length per chip select
  - Programmable phase and polarity per chip select
  - Programmable transfer delays per chip select, between consecutive transfers and between clock and data
  - Programmable delay between consecutive transfers
  - Selectable mode fault detection
  - Maximum frequency at up to Master Clock

## 10.8 Two-wire Interface

- Master Mode only
- Compatibility with I<sup>2</sup>C compatible devices (refer to the TWI section of the datasheet)
- One, two or three bytes internal address registers for easy Serial Memory access
- 7-bit or 10-bit slave addressing
- Sequential read/write operations

## 10.9 USART

- Programmable Baud Rate Generator
- 5- to 9-bit full-duplex synchronous or asynchronous serial communications
  - 1, 1.5 or 2 stop bits in Asynchronous Mode
  - 1 or 2 stop bits in Synchronous Mode
  - Parity generation and error detection
  - Framing error detection, overrun error detection
  - MSB or LSB first
  - Optional break generation and detection
  - By 8 or by 16 over-sampling receiver frequency
  - Hardware handshaking RTS - CTS
  - Modem Signals Management DTR-DSR-DCD-RI on USART1
  - Receiver time-out and transmitter timeguard
  - Multi-drop Mode with address generation and detection
- RS485 with driver control signal
- ISO7816, T = 0 or T = 1 Protocols for interfacing with smart cards
  - NACK handling, error counter with repetition and iteration limit
- IrDA modulation and demodulation
  - Communication at up to 115.2 Kbps
- Test Modes
  - Remote Loopback, Local Loopback, Automatic Echo

## 10.10 Serial Synchronous Controller

- Provides serial synchronous communication links used in audio and telecom applications
- Contains an independent receiver and transmitter and a common clock divider
- Offers a configurable frame sync and data length
- Receiver and transmitter can be programmed to start automatically or on detection of different event on the frame sync signal
- Receiver and transmitter include a data signal, a clock signal and a frame synchronization signal

## 10.11 Timer Counter

- Three 16-bit Timer Counter Channels
  - Two output compare or one input capture per channel
- Wide range of functions including:
  - Frequency measurement
  - Event counting
  - Interval measurement
  - Pulse generation
  - Delay timing
  - Pulse Width Modulation
  - Up/down capabilities
- Each channel is user-configurable and contains:
  - Three external clock inputs
- Five internal clock inputs, as defined in [Table 10-4](#)

**Table 10-4.** Timer Counter Clocks Assignment

TC Clock input	Clock
TIMER_CLOCK1	MCK/2
TIMER_CLOCK2	MCK/8
TIMER_CLOCK3	MCK/32
TIMER_CLOCK4	MCK/128
TIMER_CLOCK5	MCK/1024

- Two multi-purpose input/output signals
- Two global registers that act on all three TC channels

## 10.12 Pulse Width Modulation Controller

- Four channels, one 16-bit counter per channel
- Common clock generator, providing thirteen different clocks
  - One Modulo n counter providing eleven clocks
  - Two independent linear dividers working on modulo n counter outputs
- Independent channel programming
  - Independent enable/disable commands
  - Independent clock selection
  - Independent period and duty cycle, with double buffering
  - Programmable selection of the output waveform polarity
  - Programmable center or left aligned output waveform

### 10.13 USB Device Port

- USB V2.0 full-speed compliant, 12 Mbits per second
- Embedded USB V2.0 full-speed transceiver
- Embedded 1352-byte dual-port RAM for endpoints
- Six endpoints
  - Endpoint 0: 8 bytes
  - Endpoint 1 and 2: 64 bytes ping-pong
  - Endpoint 3: 64 bytes
  - Endpoint 4 and 5: 256 bytes ping-pong
  - Ping-pong Mode (two memory banks) for bulk endpoints
- Suspend/resume logic

### 10.14 CAN Controller

- Fully compliant with CAN 2.0A and 2.0B
- Bit rates up to 1Mbit/s
- Eight object oriented mailboxes each with the following properties:
  - CAN Specification 2.0 Part A or 2.0 Part B Programmable for each Message
  - Object configurable to receive (with overwrite or not) or transmit
  - Local tag and mask filters up to 29-bit identifier/channel
  - 32-bit access to data registers for each mailbox data object
  - Uses a 16-bit time stamp on receive and transmit message
  - Hardware concatenation of ID unmasked bitfields to speedup family ID processing
  - 16-bit internal timer for time stamping and network synchronization
  - Programmable reception buffer length up to 8 mailbox objects
  - Priority management between transmission mailboxes
  - Autobaud and listening mode
  - Low power mode and programmable wake-up on bus activity or by the application
  - Data, remote, error and overload frame handling

### 10.15 128-bit Advanced Encryption Standard

- Compliant with FIPS Publication 197, Advanced Encryption Standard (AES)
- 128-bit (AT91SAM7XC256/128) or 128-bit/192-bit/256-bit (AT91SAM7XC512) Cryptographic Key
- 12-clock Cycles Encryption/Decryption Processing Time (AT91SAM7XC256/128)
- 12/13/14-clock Cycles Encryption/Decryption Processing Time (AT91SAM7XC512)
- Support of the Five Standard Modes of Operation specified in the NIST Special Publication 800-38A:
  - Electronic Codebook (ECB)
  - Cipher Block Chaining (CBC)
  - Cipher Feedback (CFB)
  - Output Feedback (OFB)

- Counter (CTR)
- 8-, 16-, 32-, 64- and 128-bit Data Sizes Possible in CFB Mode
- Last Output Data Mode allowing Message Authentication Code (MAC) generation
- Hardware Countermeasures against Differential Power Analysis attacks
- Connection to PDC Channel Capabilities Optimizes Data Transfers for all Operating Modes:
  - One Channel for the Receiver, One Channel for the Transmitter
  - Next Buffer Support

## 10.16 Triple Data Encryption Standard

- Single Data Encryption Standard (DES) and Triple Data Encryption
- Algorithm (TDEA or TDES) supports
- Compliant with FIPS Publication 46-3, Data Encryption Standard (DES)
- 64-bit Cryptographic Key
- Two-key or Three-key Algorithms
- 18-clock Cycles Encryption/Decryption Processing Time for DES
- 50-clock Cycles Encryption/Decryption Processing Time for TDES
- Support the Four Standard Modes of Operation specified in the FIPS Publication 81, DES
- Modes of Operation:
  - Electronic Codebook (ECB)
  - Cipher Block Chaining (CBC)
  - Cipher Feedback (CFB)
  - Output Feedback (OFB)
- 8-, 16-, 32- and 64- Data Sizes Possible in CFB Mode
- Last Output Data Mode allowing Optimized Message (Data) Authentication Code (MAC) generation
- Connection to PDC Channel Capabilities Optimizes Data Transfers for all Operating Modes:
  - One Channel for the Receiver, One Channel for the Transmitter
  - Next Buffer Support

## 10.17 Analog-to-Digital Converter

- 8-channel ADC
- 10-bit 384 Ksamples/sec. Successive Approximation Register ADC
- $\pm 2$  LSB Integral Non Linearity,  $\pm 1$  LSB Differential Non Linearity
- Integrated 8-to-1 multiplexer, offering eight independent 3.3V analog inputs
- External voltage reference for better accuracy on low voltage inputs
- Individual enable and disable of each channel
- Multiple trigger sources
  - Hardware or software trigger
  - External trigger pin
  - Timer Counter 0 to 2 outputs TIOA0 to TIOA2 trigger
- Sleep Mode and conversion sequencer

- Automatic wakeup on trigger and back to sleep mode after conversions of all enabled channels
- Four of eight analog inputs shared with digital signals

# 11. Package Drawings

Figure 11-1. LQFP Package Drawing

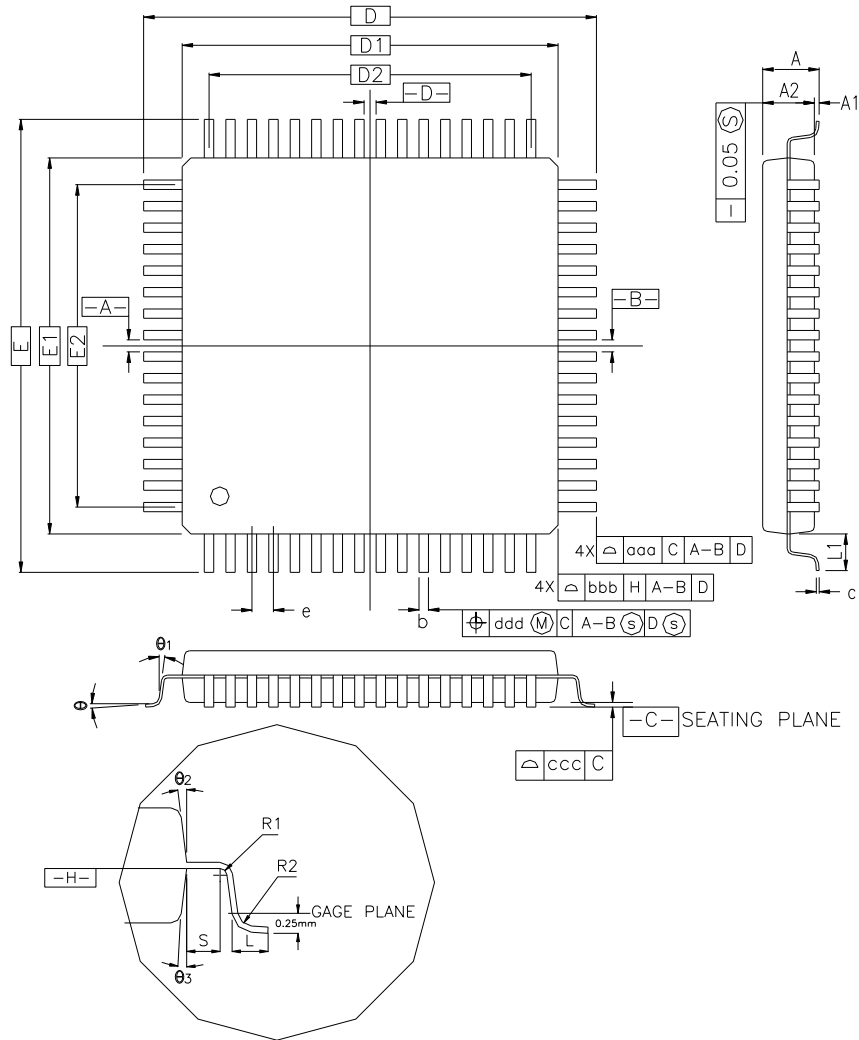

**Table 11-1.** 100-lead LQFP Package Dimensions

Symbol	Millimeter			Inch		
	Min	Nom	Max	Min	Nom	Max
A			1.60			0.63
A1	0.05		0.15	0.002		0.006
A2	1.35	1.40	1.45	0.053	0.055	0.057
D	16.00 BSC			0.630 BSC		
D1	14.00 BSC			0.551 BSC		
E	16.00 BSC			0.630 BSC		
E1	14.00 BSC			0.551 BSC		
R2	0.08		0.20	0.003		0.008
R1	0.08			0.003		
Q	0	3.5	7	0	3.5	7
θ1	0			0		
θ2	11	12	13	11	12	13
θ3	11	12	13	11	12	13
c	0.09		0.20	0.004		0.008
L	0.45	0.60	0.75	0.018	0.024	0.030
L1	1.00 REF			0.039 REF		
S	0.20			0.008		
b	0.17	0.20	0.27	0.007	0.008	0.011
e	0.50 BSC			0.020 BSC		
D2	12.00			0.472		
E2	12.00			0.472		
Tolerances of Form and Position						
aaa	0.20			0.008		
bbb	0.20			0.008		
ccc	0.08			0.003		
ddd	0.08			0.003		

**Figure 11-2. 100-TFBGA Package Drawing**

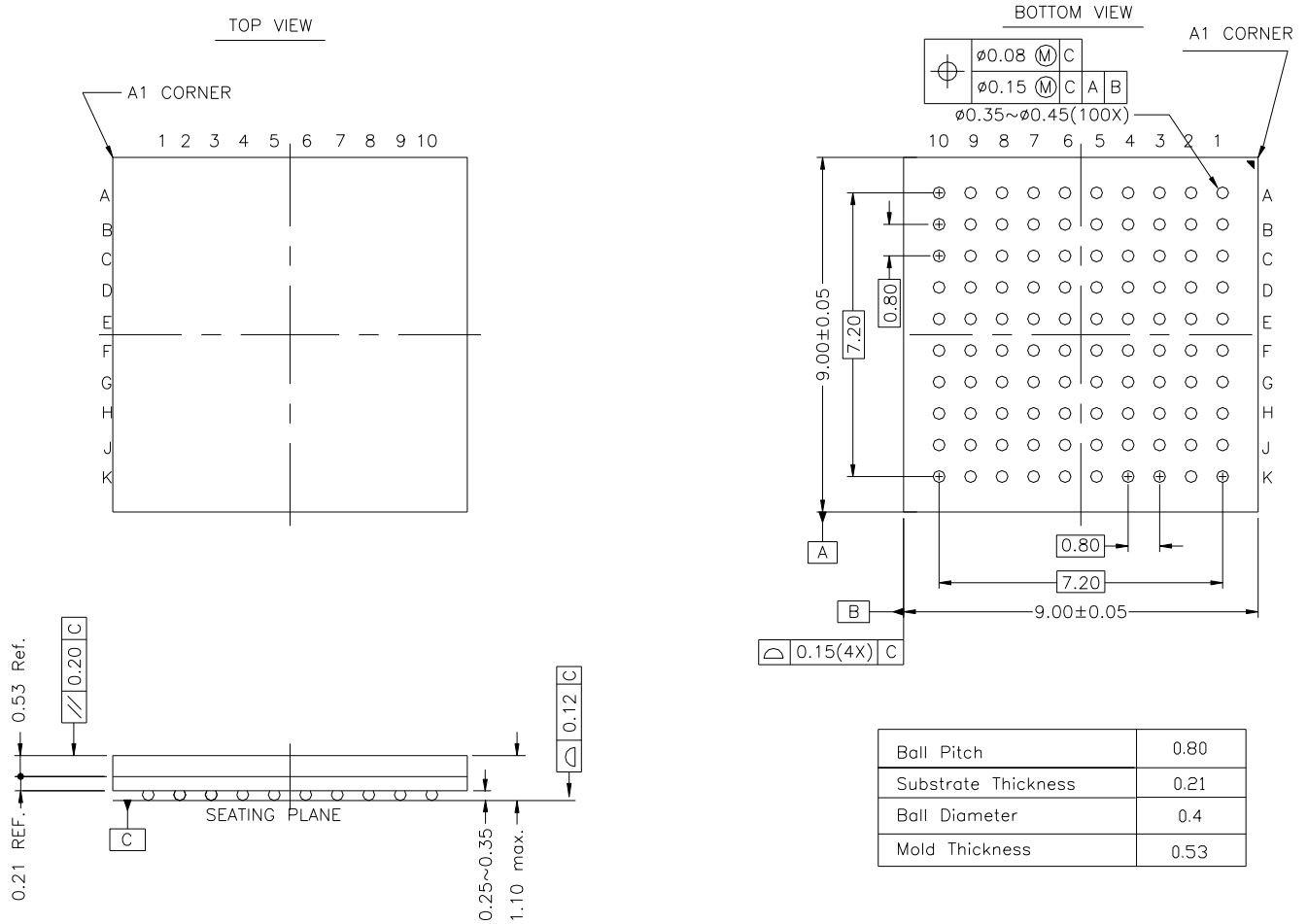

All dimensions are in mm

**12. AT91SAM7XC512/256/128 Ordering Information**

**Table 12-1.** Ordering Information

<b>MLR A Ordering Code</b>	<b>MLR B Ordering Code</b>	<b>Package</b>	<b>Package Type</b>	<b>Temperature Operating Range</b>
AT91SAM7XC512-AU AT91SAM7XC512-CU	–	LQFP 100 TFBGA 100	Green	Industrial (-40· C to 85· C)
AT91SAM7XC256-AU AT91SAM7XC256-CU	AT91SAM7XC256B-AU AT91SAM7XC256B-CU	LQFP 100 TFBGA 100	Green	Industrial (-40· C to 85· C)
AT91SAM7XC128-AU AT91SAM7XC128-CU	AT91SAM7XC128B-AU AT91SAM7XC128B-CU	LQFP 100 TFBGA 100	Green	Industrial (-40· C to 85· C)

**13. Export Regulations Statement**

These commodities, technology or software will be exported from France and the applicable Export Administration Regulations will apply. French, United States and other relevant laws, regulations and requirements regarding the export of products may restrict sale, export and re-export of these products; please assure you conduct your activities in accordance with the applicable relevant export regulations.

## Revision History

**Table 13-1.** Revision History

Doc. Rev	Comments	Change Request Ref.
6209S	First issue - Unqualified on Intranet Legal page updated. Qualified on Intranet	
6209BS	Added AT91SAM7XC512 to product family. "Features" on page 1 and global Reformatted Memories Section 8. "Memory" on page 18. Reordered sub sections in Peripherals Section 10. "Peripherals" on page 32 Consolidated Memory Mapping in Figure 8-1 on page 19. Added package drawings Section 11. "Package Drawings" on page 42. Consolidated Memory Mapping in Figure 8-1 on page 19. Added TFBGA information Section 4.3 "100-ball TFBGA Package Outline" on page 11. and Section 4.4 on page 10 and "Features" on page 1 Added LQFP and TFBGA package drawings Section 11. on page 42. System Controller block diagram Figure 9-1 on page 26, "ice_nreset" signals changed to "power_on_reset".	2729
6209CS	"Features", TWI updated to include Atmel TWI compatibility with I <sup>2</sup> C Standard. "Features", "Debug Unit (DBGU)" added "Mode for General Purpose 2-wire UART Serial Communication". Section 10.8 "Two-wire Interface", updated. Section 10.11 "Timer Counter", The TC has Two output compare or one input capture per channel. Section 10.17 "Analog-to-Digital Converter", INL and DNL updated. Figure 3-1, "Signal Description List", footnote added to JTAGSEL, ERASE and TST pin comments Section 6.1 "JTAG Port Pins", Section 6.2 "Test Pin" and Section 6.4 "ERASE Pin" updated. Figure 9-1, "System Controller Block Diagram", RTT is reset by power_on_reset. Figure 8-1, "AT91SAM7XC512/256/128 Memory Mapping", TDES base address is 0xFFFFA 8000 Section 8.4.3 "Internal Flash", updated: "At any time, the Flash is mapped ... if GPNVM bit 2 is set and before the Remap Command."	4247 5846  4211 4008 5068  5225 5257 5850
6209DS	Section 12. "AT91SAM7XC512/256/128 Ordering Information", MLR B chip revision added to ordering information.	6064

≤



## Headquarters

---

**Atmel Corporation**  
2325 Orchard Parkway  
San Jose, CA 95131  
USA  
Tel: 1(408) 441-0311  
Fax: 1(408) 487-2600

## International

---

**Atmel Asia**  
Unit 1-5 & 16, 19/F  
BEA Tower, Millennium City 5  
418 Kwun Tong Road  
Kwun Tong, Kowloon  
Hong Kong  
Tel: (852) 2245-6100  
Fax: (852) 2722-1369

**Atmel Europe**  
Le Krebs  
8, Rue Jean-Pierre Timbaud  
BP 309  
78054 Saint-Quentin-en-  
Yvelines Cedex  
France  
Tel: (33) 1-30-60-70-00  
Fax: (33) 1-30-60-71-11

**Atmel Japan**  
9F, Tonetsu Shinkawa Bldg.  
1-24-8 Shinkawa  
Chuo-ku, Tokyo 104-0033  
Japan  
Tel: (81) 3-3523-3551  
Fax: (81) 3-3523-7581

## Product Contact

---

**Web Site**  
[www.atmel.com](http://www.atmel.com)  
[www.atmel.com/AT91SAM](http://www.atmel.com/AT91SAM)  
[www.atmel.com/lproducts/ASIC](http://www.atmel.com/lproducts/ASIC)

**Technical Support**  
AT91SAM Support  
Atmel technical support

**Sales Contacts**  
[www.atmel.com/contacts/](http://www.atmel.com/contacts/)

**Literature Requests**  
[www.atmel.com/literature](http://www.atmel.com/literature)

---

**Disclaimer:** The information in this document is provided in connection with Atmel products. No license, express or implied, by estoppel or otherwise, to any intellectual property right is granted by this document or in connection with the sale of Atmel products. **EXCEPT AS SET FORTH IN ATMEL'S TERMS AND CONDITIONS OF SALE LOCATED ON ATMEL'S WEB SITE, ATMEL ASSUMES NO LIABILITY WHATSOEVER AND DISCLAIMS ANY EXPRESS, IMPLIED OR STATUTORY WARRANTY RELATING TO ITS PRODUCTS INCLUDING, BUT NOT LIMITED TO, THE IMPLIED WARRANTY OF MERCHANTABILITY, FITNESS FOR A PARTICULAR PURPOSE, OR NON-INFRINGEMENT. IN NO EVENT SHALL ATMEL BE LIABLE FOR ANY DIRECT, INDIRECT, CONSEQUENTIAL, PUNITIVE, SPECIAL OR INCIDENTAL DAMAGES (INCLUDING, WITHOUT LIMITATION, DAMAGES FOR LOSS OF PROFITS, BUSINESS INTERRUPTION, OR LOSS OF INFORMATION) ARISING OUT OF THE USE OR INABILITY TO USE THIS DOCUMENT, EVEN IF ATMEL HAS BEEN ADVISED OF THE POSSIBILITY OF SUCH DAMAGES.** Atmel makes no representations or warranties with respect to the accuracy or completeness of the contents of this document and reserves the right to make changes to specifications and product descriptions at any time without notice. Atmel does not make any commitment to update the information contained herein. Unless specifically provided otherwise, Atmel products are not suitable for, and shall not be used in, automotive applications. Atmel's products are not intended, authorized, or warranted for use as components in applications intended to support or sustain life.



© 2008 Atmel Corporation. All rights reserved. Atmel®, Atmel logo and combinations thereof, DataFlash®, SAM-BA® and others, are registered trademarks or trademarks of Atmel Corporation or its subsidiaries. Windows® and others, are registered trademarks of Microsoft Corporation in the US and/or other countries. ARM®, the ARM Powered® logo and others, are registered trademarks or trademarks of ARM Limited. Other terms and product names may be the trademarks of others.

## Looking for pricing, stock, or lifecycle information?

Click below to explore more details on WIN SOURCE:

 [View AT91SAM7XC128-AU on WIN SOURCE](#)

 [Atmel Information](#)

## Optimize Your Supply Chain with WIN SOURCE Solutions

-  Global Sourcing Solution
-  Obsolete Management
-  Cost Control Management
-  Shortage Management
-  Alternative Solution
-  Excess Inventory Management