



THE DATASHEET OF
73S8010C-IL/F



DESCRIPTION

The Teridian 73S8010C is a single smart card interface IC. It provides full electrical compliance with ISO-7816-3 and EMV 4.0 specifications.

Interfacing with the host is done through the two-wire I2C bus. Data exchange with the card is managed from the system controller using the I/O line (and eventually the auxiliary I/O lines).

An on-chip oscillator using an external crystal, or connection to a clock signal coming from the system controller can generate the card clock signal.

The 73S8010C IC incorporates an ISO-7816-3 activation/deactivation sequencer that controls the card signals. Level shifters drive the card signals with the selected card voltage (3 V or 5 V), coming from an internal DC-DC converter.

With its high-efficiency DC-DC converter, the Teridian 73S8010C is a cost-effective solution for any smart card reader application to be powered from a single 2.7 V to 3.6 V power supply.

Hardware support for auxiliary I/O lines, C4 / C8 contacts, is provided.

Emergency card deactivation is initiated upon card extraction or upon any fault generated by the protection circuitry. The fault can be a VDD (digital power supply), a VCC (card power supply), a card over-current, or an over-heating fault.

ADVANTAGES

- Single smart card interface
- The inductor-based DC-DC converter provides higher current and efficiency than the usual charge-pump capacitor-based converters
 - Ideal for battery-powered applications
 - Suitable for high current cards and SAMs: (100 mA max)
- Power down mode: 2 μ A typical
- Small Format (5x5mm) 32-QFN package option

FEATURES

- **Card Interface:**
 - Complies with ISO-7816-3 and EMV 4.0
 - A DC-DC Converter provides 3V / 5V to the card from an external power supply input
 - High-efficiency converter: > 80% @ V_{DD} = 3.3 V, V_{CC} = 5 V and I_{CC} = 65 mA
 - Up to 100 mA supplied to the card
 - ISO-7816-3 Activation / Deactivation sequencer with emergency automated deactivation on card removal or fault detected by the protection circuitry
 - Protection include 2 voltage supervisors that detect voltage drops on card V_{CC} and V_{DD} power supplies
 - The V_{DD} voltage supervisor threshold value can be externally adjusted
 - True over-current detection (150 mA max.)
 - 1 card detection input
 - Auxiliary I/O lines, for C4 / C8 contact signals
- **Host Interface:**
 - Fast mode, 400 kbps I²C slave bus
 - 8 possible devices in parallel
 - One control register and one status register
 - Interrupt output to the host for fault detection
 - Crystal oscillator or host clock, up to 27 MHz
- **Power Supply:**
 - V_{DD} : 2.7 V to 3.6 V
- **6 kV ESD Protection on the card interface**
- **Package: SO28 or 32QFN**

APPLICATIONS

- Set-Top-Boxes, DVD / HDD Recorders: Conditional Access and Pay-per-View slots
- Point of Sales and Transaction Terminals
- EMV slots in cell phones and PDAs

FUNCTIONAL DIAGRAM

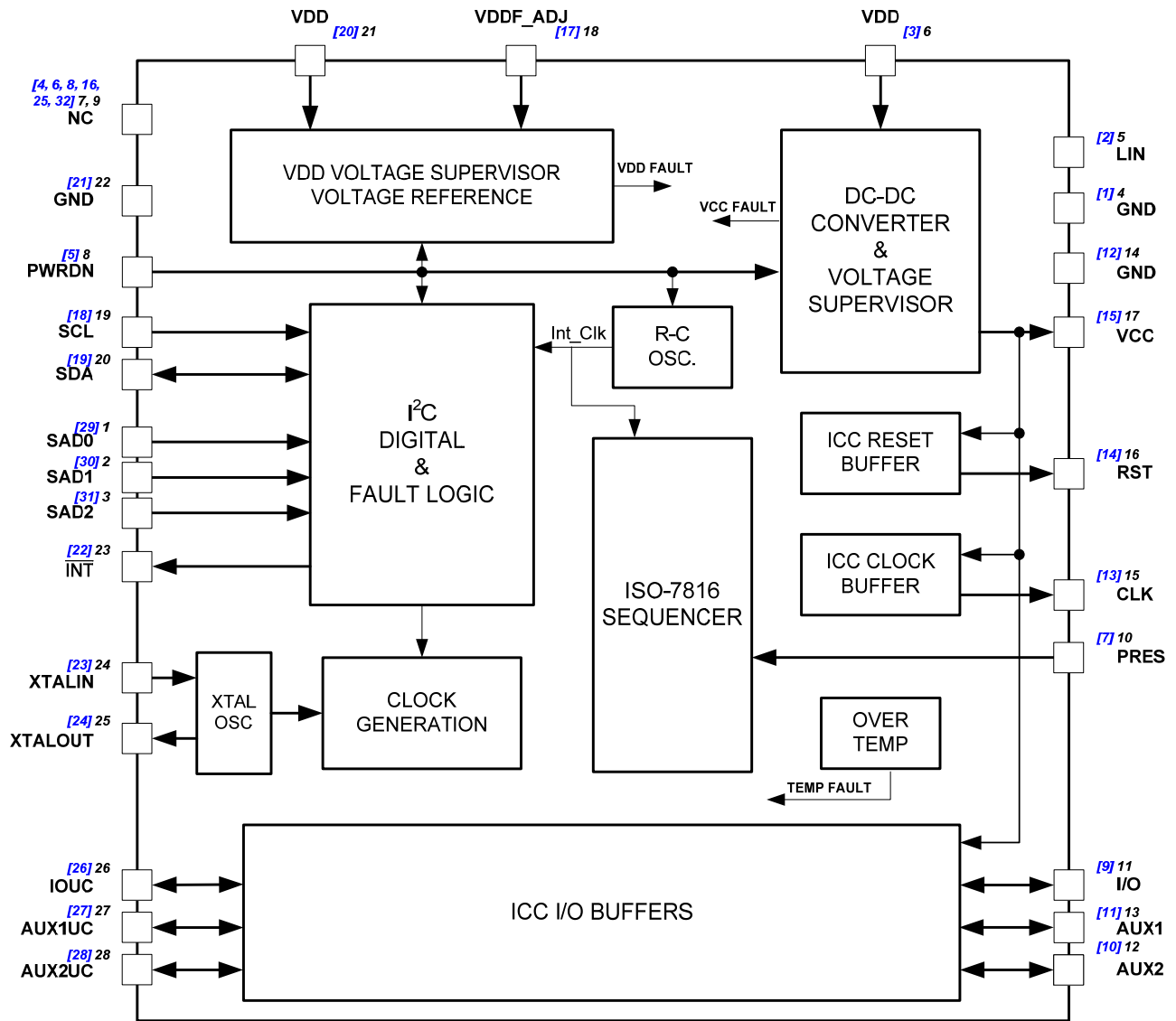

Figure 1: 73S8010C Block Diagram

Pin number reference to SO28 Package
 [Pin number] reference to 32QFN Package

Table of Contents

| | | |
|-----------|---|-----------|
| 1 | Pin Description | 5 |
| 1.1 | Card Interface | 5 |
| 1.2 | Miscellaneous Inputs and Outputs..... | 5 |
| 1.3 | Power Supply and Ground..... | 5 |
| 1.4 | Microcontroller Interface | 6 |
| 2 | Host Interface (I²C Bus) | 7 |
| 2.1 | Host Interface Control | 7 |
| 2.2 | Host Interface Status | 8 |
| 2.3 | I ² C-bus Timing | 9 |
| 3 | Oscillator | 10 |
| 4 | DC-DC Converter – Card Power Supply | 10 |
| 5 | Voltage Supervision | 11 |
| 6 | Power Down | 11 |
| 7 | Over-temperature Monitor | 12 |
| 8 | Activation Sequence | 12 |
| 9 | Deactivation Sequence | 13 |
| 10 | Interrupt | 13 |
| 11 | Warm Reset | 14 |
| 12 | I/O Timing | 14 |
| 13 | Typical Application Schematic | 15 |
| 14 | Electrical Specification | 16 |
| 14.1 | Absolute Maximum Ratings | 16 |
| 14.2 | Recommended Operating Conditions..... | 16 |
| 14.3 | DC Characteristics: Card Interface | 17 |
| 14.4 | DC Characteristics: Digital Signals | 20 |
| 14.5 | DC Characteristics: Supply | 20 |
| 14.6 | DC Characteristics: I ² C Interface..... | 21 |
| 14.7 | Voltage / Temperature Fault Detection Circuits..... | 21 |
| 15 | Mechanical Drawings | 22 |
| 15.1 | 32-pin QFN | 22 |
| 15.2 | 28-pin SO..... | 23 |
| 16 | Package Pin Designation | 24 |
| 16.1 | 32-pin QFN | 24 |
| 16.2 | 28-pin SO..... | 25 |
| 17 | Ordering Information | 26 |
| 18 | Related Documentation | 26 |
| 19 | Contact Information | 26 |
| | Revision History | 27 |

Figures

| | |
|---|----|
| Figure 1: 73S8010C Block Diagram | 2 |
| Figure 2: I ² C Bus Write Protocol | 8 |
| Figure 3: I ² C Bus Read Protocol | 9 |
| Figure 4: I ² C Bus Timing Diagram | 9 |
| Figure 5: Power Down Mode Operation..... | 12 |
| Figure 6: Activation Sequence | 12 |
| Figure 7: Deactivation Sequence..... | 13 |
| Figure 8: FAULT Functions, INT operation | 13 |
| Figure 9: Warm Reset operation | 14 |
| Figure 10: I/O Timing | 14 |
| Figure 11: 73S8010C – Typical Application Schematic..... | 15 |
| Figure 12: DC – DC Converter Efficiency (V _{CC} = 5 V) | 18 |
| Figure 13: DC – DC Converter Efficiency (V _{CC} = 3 V) | 18 |
| Figure 14: 32-pin QFN Package Drawing | 22 |
| Figure 15: 28-pin SO Package Drawing | 23 |

Tables

| | |
|--|----|
| Table 1: Device Address Selections | 7 |
| Table 2: Host Control Register..... | 7 |
| Table 3: Host Status Register | 8 |
| Table 4: Choice of V _{CC} Capacitor | 10 |

1 Pin Description

1.1 Card Interface

| Name | Pin (SO) | PIN (QFN) | Description |
|------|----------|-----------|--|
| I/O | 11 | 9 | Card I/O: Data signal to/from card. Includes a pull-up resistor to V_{CC} . |
| AUX1 | 13 | 11 | AUX1: Auxiliary data signal to/from card. Includes a pull-up resistor to V_{CC} . |
| AUX2 | 12 | 10 | AUX2: Auxiliary data signal to/from card. Includes a pull-up resistor to V_{CC} . |
| RST | 16 | 14 | Card reset: provides reset (RST) signal to card. |
| CLK | 15 | 13 | Card clock: provides clock (CLK) signal to card. The rate of this clock is determined by the crystal oscillator frequency and CLKSEL bits in the control register. |
| PRES | 10 | 7 | Card Presence switch: active high indicates card is present. Includes a pull-down resistor. |
| VCC | 17 | 15 | Card power supply: logically controlled by sequencer, output of DC-DC converter. Requires an external filter capacitor to the card GND. |
| GND | 14 | 12 | Card ground. |

1.2 Miscellaneous Inputs and Outputs

| Name | PIN (SO) | PIN (QFN) | Description |
|----------|----------|---------------------|--|
| XTALIN | 24 | 23 | Crystal oscillator input: can either be connected to a crystal or driven as a source for the card clock. |
| XTALOUT | 25 | 24 | Crystal oscillator output: connected to crystal. Left open if XTALIN is being used as an external clock input. |
| VDDF_ADJ | 18 | 17 | V_{DD} threshold adjustment input: this pin can be used to overwrite a higher V_{DDF} value (that controls deactivation of the card). Must be left open if unused. |
| NC | 7, 9 | 4, 6, 8, 16, 25, 32 | Non-connected pin. |

1.3 Power Supply and Ground

| Name | PIN (SO) | Pin (QFN) | Description |
|------|----------|-----------|--|
| VDD | 6, 21 | 3, 20 | System controller interface supply voltage: supply voltage for internal circuitry and DC-DC converter power supply source. |
| GND | 4 | 1 | DC-DC converter ground. |
| GND | 14 | 12 | Smart Card I/O ground. |
| GND | 22 | 21 | Digital ground. |
| LIN | 5 | 2 | External inductor: Connect external inductor from pin 5 to V_{DD} . Keep the inductor close to pin 5. |

1.4 Microcontroller Interface

| Name | PIN (SO) | PIN (QFN) | Description | | | | | | | | | | | | | | | | | | | | | | | | | | | | | | | | | | | | |
|----------------------|-------------|----------------|---|------|------|------|-----------------------------------|---|---|---|------|---|---|---|------|---|---|---|------|---|---|---|------|---|---|---|------|---|---|---|------|---|---|---|------|---|---|---|------|
| INT | 23 | 22 | Interrupt output (negative assertion): Interrupt output signal to the processor. A 20 k Ω pull up to V _{DD} is provided internally. | | | | | | | | | | | | | | | | | | | | | | | | | | | | | | | | | | | | |
| PWRDN | 8 | 5 | Power Down control input: Active High. When Power Down (PD) mode is activated, all internal analog functions are disabled to place the 73S8010C in its lowest power consumption mode. Must be tied to ground when the power down function is not used. | | | | | | | | | | | | | | | | | | | | | | | | | | | | | | | | | | | | |
| SAD0 SAD1 SAD2 | 1 2 3 | 29 30 31 | <p>Serial device address bits: Digital inputs for address selection that allow the connection of up to 8 devices in parallel. Address selections as follows:</p> <table border="1" data-bbox="664 590 1289 930"> <thead> <tr> <th>SAD2</th> <th>SAD1</th> <th>SAD0</th> <th>I²C Address (7 bits)</th> </tr> </thead> <tbody> <tr> <td>0</td> <td>0</td> <td>0</td> <td>0x40</td> </tr> <tr> <td>0</td> <td>0</td> <td>1</td> <td>0x42</td> </tr> <tr> <td>0</td> <td>1</td> <td>0</td> <td>0x44</td> </tr> <tr> <td>0</td> <td>1</td> <td>1</td> <td>0x46</td> </tr> <tr> <td>1</td> <td>0</td> <td>0</td> <td>0x48</td> </tr> <tr> <td>1</td> <td>0</td> <td>1</td> <td>0x4A</td> </tr> <tr> <td>1</td> <td>1</td> <td>0</td> <td>0x4C</td> </tr> <tr> <td>1</td> <td>1</td> <td>1</td> <td>0x4E</td> </tr> </tbody> </table> <p> Pins SAD0 and SAD1 are internally pulled-down and SAD2 is internally pulled-up. The default address when left unconnected is 48h.</p> | SAD2 | SAD1 | SAD0 | I ² C Address (7 bits) | 0 | 0 | 0 | 0x40 | 0 | 0 | 1 | 0x42 | 0 | 1 | 0 | 0x44 | 0 | 1 | 1 | 0x46 | 1 | 0 | 0 | 0x48 | 1 | 0 | 1 | 0x4A | 1 | 1 | 0 | 0x4C | 1 | 1 | 1 | 0x4E |
| SAD2 | SAD1 | SAD0 | I ² C Address (7 bits) | | | | | | | | | | | | | | | | | | | | | | | | | | | | | | | | | | | | |
| 0 | 0 | 0 | 0x40 | | | | | | | | | | | | | | | | | | | | | | | | | | | | | | | | | | | | |
| 0 | 0 | 1 | 0x42 | | | | | | | | | | | | | | | | | | | | | | | | | | | | | | | | | | | | |
| 0 | 1 | 0 | 0x44 | | | | | | | | | | | | | | | | | | | | | | | | | | | | | | | | | | | | |
| 0 | 1 | 1 | 0x46 | | | | | | | | | | | | | | | | | | | | | | | | | | | | | | | | | | | | |
| 1 | 0 | 0 | 0x48 | | | | | | | | | | | | | | | | | | | | | | | | | | | | | | | | | | | | |
| 1 | 0 | 1 | 0x4A | | | | | | | | | | | | | | | | | | | | | | | | | | | | | | | | | | | | |
| 1 | 1 | 0 | 0x4C | | | | | | | | | | | | | | | | | | | | | | | | | | | | | | | | | | | | |
| 1 | 1 | 1 | 0x4E | | | | | | | | | | | | | | | | | | | | | | | | | | | | | | | | | | | | |
| SCL | 19 | 18 | I ² C clock signal input. | | | | | | | | | | | | | | | | | | | | | | | | | | | | | | | | | | | | |
| SDA | 20 | 19 | I ² C bi-directional serial data signal. | | | | | | | | | | | | | | | | | | | | | | | | | | | | | | | | | | | | |
| I/OUC | 26 | 26 | System controller data I/O to/from the card. Includes internal pull-up resistor to V _{DD} . | | | | | | | | | | | | | | | | | | | | | | | | | | | | | | | | | | | | |
| AUX1UC | 27 | 27 | System controller auxiliary data I/O to/from the card. Includes internal pull-up resistor to V _{DD} . | | | | | | | | | | | | | | | | | | | | | | | | | | | | | | | | | | | | |
| AUX2UC | 28 | 28 | System controller auxiliary data I/O to/from the card. Includes internal pull-up resistor to V _{DD} . | | | | | | | | | | | | | | | | | | | | | | | | | | | | | | | | | | | | |

2 Host Interface (I²C Bus)

A fast-mode 400 kHz I²C bus slave interface is used for controlling the device and reading the status of the device via the data pin SDA and clock pin SCL. The bus has 3 address select pins, SAD0, SAD1, and SAD2. This allows up to 8 devices to be connected in parallel.

Table 1: Device Address Selections

| SAD2 | SAD1 | SAD0 | I ² C Address (7 bits) |
|------|------|------|-----------------------------------|
| 0 | 0 | 0 | 0x40 |
| 0 | 0 | 1 | 0x42 |
| 0 | 1 | 0 | 0x44 |
| 0 | 1 | 1 | 0x46 |
| 1 | 0 | 0 | 0x48 |
| 1 | 0 | 1 | 0x4A |
| 1 | 1 | 0 | 0x4C |
| 1 | 1 | 1 | 0x4E |

Bit 0 of the I²C address is the R/W bit. Refer to [Figure 2](#) and [Figure 3](#) for usage.

2.1 Host Interface Control

Table 2 describes the Host Interface Control Register bits (power-on Reset = 0x00).

Table 2: Host Control Register

| Name | Bit | Description | | | | | | | | | | | | | | | |
|------------------|---------|---|------------|---------|------------|---|---|----------|---|---|----------|---|---|----------|---|---|--------|
| Start/Stop | 0 | When set, initiates an activation and a cold reset procedure; when reset, initiates a deactivation sequence. | | | | | | | | | | | | | | | |
| Warm reset | 1 | When set, initiates a warm reset procedure; automatically reset by hardware when the card starts answering or when the card is declared mute. | | | | | | | | | | | | | | | |
| 5 V and 3 V | 2 | When set, V _{CC} = 3 V; when reset, V _{CC} = 5 V. | | | | | | | | | | | | | | | |
| Clock Stop | 3 | When set, card clock is stopped. Bit 4 determines the card clock stop level. | | | | | | | | | | | | | | | |
| Clock Stop Level | 4 | When set, card clock stops high; when reset card clock stops low. | | | | | | | | | | | | | | | |
| Clksel1 | 5 | Bits 5 and 6 determine the clock rate to the card according to the following table. <table border="1" style="margin-left: auto; margin-right: auto;"> <thead> <tr> <th>CLKDIV1</th> <th>CLKDIV2</th> <th>Clock Rate</th> </tr> </thead> <tbody> <tr> <td>0</td> <td>0</td> <td>XTALIN/8</td> </tr> <tr> <td>0</td> <td>1</td> <td>XTALIN/4</td> </tr> <tr> <td>1</td> <td>1</td> <td>XTALIN/2</td> </tr> <tr> <td>1</td> <td>0</td> <td>XTALIN</td> </tr> </tbody> </table> | CLKDIV1 | CLKDIV2 | Clock Rate | 0 | 0 | XTALIN/8 | 0 | 1 | XTALIN/4 | 1 | 1 | XTALIN/2 | 1 | 0 | XTALIN |
| CLKDIV1 | CLKDIV2 | | Clock Rate | | | | | | | | | | | | | | |
| 0 | 0 | | XTALIN/8 | | | | | | | | | | | | | | |
| 0 | 1 | | XTALIN/4 | | | | | | | | | | | | | | |
| 1 | 1 | XTALIN/2 | | | | | | | | | | | | | | | |
| 1 | 0 | XTALIN | | | | | | | | | | | | | | | |
| Clksel2 | 6 | | | | | | | | | | | | | | | | |
| I/O enable | 7 | When set, data is transferred between I/O (AUX1, AUX2) and I/OUC (AUX1UC, AUX2UC); when reset, I/O (AUX1, AUX2) and I/OUC (AUX1UC, AUX2UC) are high impedance. | | | | | | | | | | | | | | | |

I²C-bus Write to the Control Register

The I²C-bus Write command to the control register follows the format shown in [Figure 2](#).

After the START condition, the master sends a slave address. This address is seven bits long followed by an eighth bit, which is an opcode bit (R/W) – a ‘zero’ indicates the master will write data to the control register. After the R/W bit, the ‘zero’ ACK bit is sent to the master by the device. The master now starts sending the 8 bits of data to the control register during the DATA bits time. After the DATA bits, the ‘zero’

ACK bit is sent to the master by the device. The master should send the STOP condition after receiving the ACK bit.

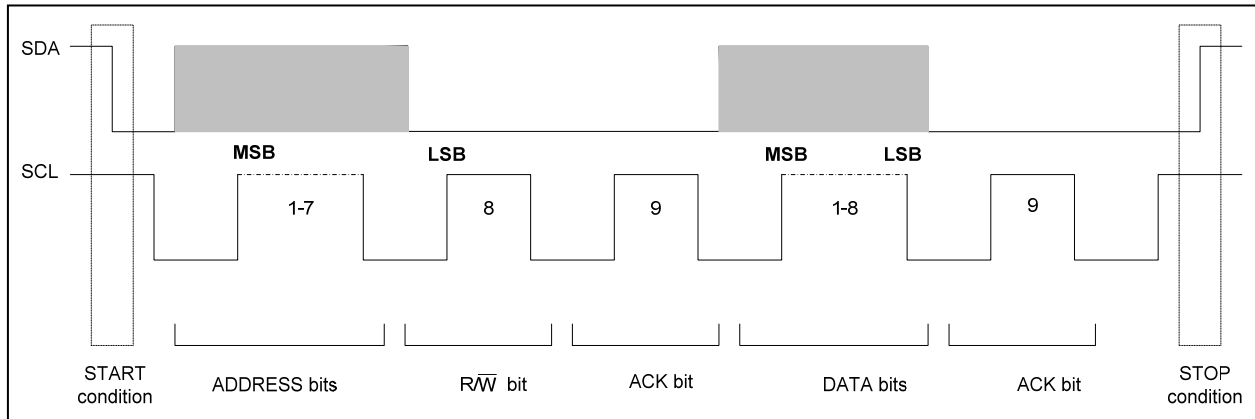

Figure 2: I²C Bus Write Protocol

2.2 Host Interface Status

Table 3 describes the Host Interface Status Register bits (power-on Reset = 0x04).

Table 3: Host Status Register

| Name | Bit | Description |
|--------|-----|---|
| PRES | 0 | Set when the card is present; reset when the card is not present. |
| PRESL | 1 | Set when the PRES pin changes state (rising/falling edge); reset when the status register is read. Generates an interrupt when set |
| I/O | 2 | Set when I/O is high; reset when I/O is low. |
| SUPL | 3 | Set when a voltage fault is detected; reset when the status register is read. Generates an interrupt when set. |
| PROT | 4 | Set when an over-current or over-heating fault has occurred during a card session; reset when the status register is read. Generates an interrupt when set. |
| MUTE | 5 | Set during ATR when the card has not answered during the ISO 7816-3 time window (40000 card clock cycles); reset when the next session begins or this register is read. |
| EARLY | 6 | Set during ATR when the card has answered before 400 card clock cycles; reset when the next session begins or this register is read. |
| ACTIVE | 7 | Set when the card is active (V_{CC} is on); reset when the card is inactive. |

I²C-bus Read from the Status Register:

The I²C-bus Read Command from the Status Register follows the format shown in [Figure 3](#).

After the START condition, the master sends a slave address. This address is seven bits long followed by an eighth bit, which is the opcode bit (R/\bar{W}). A 'one' indicates the master will read data from the status register. After the R/\bar{W} bit, the 'zero' ACK bit is sent to the master by the device. The device now starts sending the 8-bit status register data to the control register during the DATA bits time. After the DATA bits, the 'one' ACK bit is sent to the device by the master. The master should send the STOP condition after receiving the ACK bit.

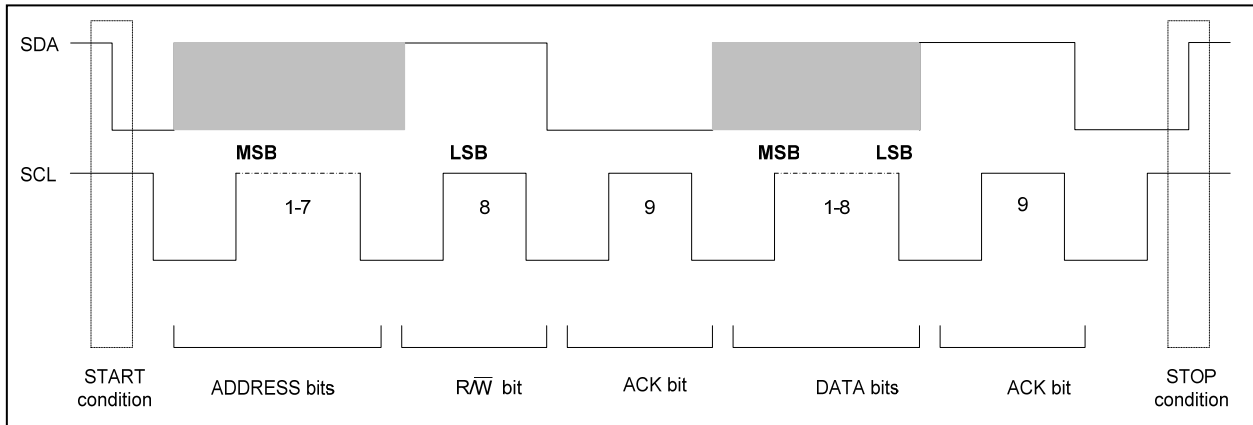

Figure 3: I²C Bus Read Protocol

2.3 I²C-bus Timing

| Symbol | Parameter | Conditions | Min. | Typ. | Max. | UNIT |
|--------|--|------------|------|------|------|------|
| Fsclk | Clock frequency | | | | 400 | kHz |
| Tlow | Clock low | | 1.3 | | | μs |
| Thi | Clock high | | 0.6 | | | μs |
| Thdsta | Hold time START condition | | 0.6 | | | μs |
| Tsudat | Data set up time | | 100 | | | ns |
| Thddat | Data hold time | | 5 | | 900 | ns |
| Tsusto | Set up time STOP condition | | 0.6 | | | μs |
| Tbuf | Bus free time between a STOP and START condition | | 1.3 | | | μs |

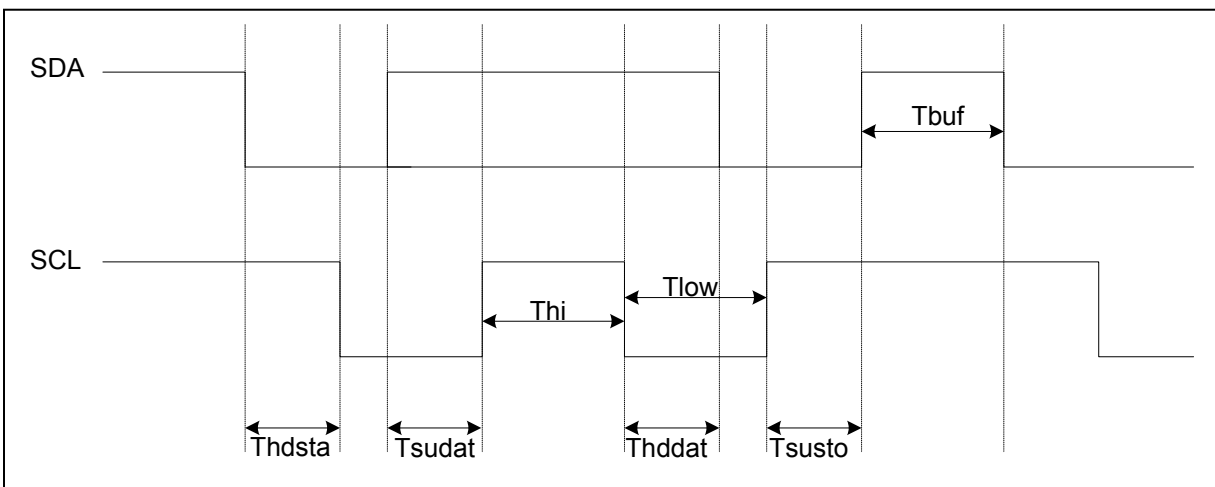

Figure 4: I²C Bus Timing Diagram

3 Oscillator

The Teridian 73S8010C device has an on-chip oscillator that can generate the smart card clock using an external crystal, connected between the XTALIN and XTALOUT pins, to set the oscillator frequency. When the card clock signal is available from another source, it can be connected to the pin XTALIN, and the pin XTALOUT should be left unconnected.

4 DC-DC Converter – Card Power Supply

An internal DC-DC converter provides the card power supply. This converter is able to provide either a 3 V or 5 V card voltage from the power supply applied on the V_{DD} pin. The digital ISO-7816-3 sequencer controls the converter. Bit 2 of the Control register selects the card voltage.

The circuit is an inductive step-up converter/regulator. The external components required are 2 filter capacitors on the power-supply input V_{DD} (100 nF + 10 μ F, next to the LIN pin), an inductor, and an output filter capacitor on the card power supply V_{CC} . The circuit performs regulation by activating the step-up operation when V_{CC} is below a set point of 5.0 or 3.0 volts minus a comparator hysteresis voltage and the input supply V_{DD} is less than the set point for V_{CC} . When V_{DD} is greater than the set point for V_{CC} ($V_{DD} = 3.6$ V, $V_{CC} = 3$ V) the circuit operates as a linear regulator. Depending on the inductor values, the voltage converter can provide current on V_{CC} as high as 100 mA.

The circuit provides over-current protection and limits I_{CC} to 150 mA. When an over-current condition is sensed, the circuit initiates a deactivation sequence from the control logic and reports back to the host controller a fault on the interrupt output \overline{INT} .

Choice of the Inductor

The nominal inductor value is 10 μ H, rated for 400 mA. The inductor is connected between pin LIN (pin 5 in the SO package, pin 2 in the QFN package) and the V_{DD} voltage. The value of the inductor can be optimized to meet a particular configuration (I_{CC_MAX}). The inductor should be located on the PCB as close as possible to the LIN pin of the IC.

Choice of the V_{CC} Capacitor

Depending on the applications, the requirements in terms of both V_{CC} minimum voltage and transient currents that the interface must be able to provide to the card vary. [Table 4](#) shows the recommended capacitors for each V_{CC} power supply configuration and applicable specification.

Table 4: Choice of Vcc Capacitor

| Specification Requirement | | | Application | |
|---------------------------|---|------------------------------|------------------------------------|-----------------|
| Specification | Min V_{CC} Voltage Allowed During Transient Current | Max Transient Current Charge | Capacitor Type | Capacitor Value |
| EMV 4.0 | 4.6V | 30nA.s | X5R/X7R w/ ESR < 100 m Ω | 3.3 μ F |
| ISO-7816-3 | 4.5V | 20nA.s | | 1 μ F |

5 Voltage Supervision

Two voltage supervisors constantly check the level of the V_{DD} and V_{CC} voltages. A card deactivation sequence is forced when a fault occurs for any of these voltage supervisors.

The digital circuitry is powered by the power supply applied on the VDD pin. V_{DD} also defines the voltage range to interface with the system controller. The V_{DD} voltage supervisor is also used to initialize the ISO-7816-3 sequencer at power-on, and to deactivate the card at power-off or when a fault occurs. The voltage threshold of the V_{DD} voltage supervisor is internally set by default to 2.3 V nominal. However, it may be desirable in some applications, to modify this threshold value. The pin VDDF_ADJ (pin 18 in the SO package, pin 17 in the QFN package) is used to connect an external resistor R_{EXT1} to ground to raise the V_{DD} fault voltage to another value, V_{DDF} (refer to Figure 11). The resistor value is defined as follows:

$$R_{EXT} = 180 \text{ k}\Omega / (V_{DDF} - 2.33)$$

An alternative (more accurate) method of adjusting the V_{DD} fault voltage is to use a resistive network of R3 from the pin to supply and R4 from the pin to ground (see Figure 11). In order to set the new threshold voltage, the equivalent resistance must be determined. This resistance value will be designated Kx. Kx is defined as $R4/(R4+R5)$. Kx is calculated as:

$$Kx = (2.649 / V_{TH}) - 0.6042 \text{ where } V_{TH} \text{ is the desired new threshold voltage.}$$

To determine the values of R4 and R5, use the following formulas.

$$R5 = 72000 / Kx \quad R4 = R5 * (Kx / (1 - Kx))$$

Taking the example above, where a V_{DD} fault threshold voltage of 2.7 V is desired, solving for Kx gives:

$$\rightarrow Kx = (2.649 / 2.7) - 0.6042 = 0.377.$$

Solving for R5 gives: $\rightarrow R5 = 72000 / 0.377 = 191 \text{ k}\Omega$.

Solving for R4 gives: $\rightarrow R4 = 191000 * (0.377 / (1 - 0.377)) = 115.6 \text{ k}\Omega$.

Using standard 1% resistor values gives $R5 = 191 \text{ k}\Omega$ and $R4 = 115 \text{ k}\Omega$. These values give an equivalent resistance of $Kx = 0.376$, a 0.3% error.

If the 2.3 V default threshold is used, the VDDF_ADJ pin must be left unconnected.

6 Power Down

A power down function is provided via the PWRDN pin (active high). When activated, the Power Down (PD) mode disables all the internal analog functions, including the card analog interface, the oscillators and the DC-DC converter, to put the 73S8010C in its lowest power consumption mode. PD mode is only allowed in the deactivated condition (out of a card session, when the Start/Stop bit is set to 0 from the I²C host controller).

The host controller invokes the power down state when it is desirable to save power. The signal PRES remains functional in PD mode such that a card insertion sets \overline{INT} high. The micro-controller must then set PWRDN low and wait for the internal stabilization time prior to starting any card session (prior to setting the Start/Stop bit to 1).

Resumption of the normal mode occurs approximately 10 ms (stabilization of the internal oscillators + reset of the circuitry) after PWRDN is set low. No card activation should be invoked during this 10 ms time period. If a card is present, \overline{INT} can be used as an indication that the circuit has completed its recovery from power down state. \overline{INT} will go high at the end of the stabilization period. Should the Start/Stop be set to 1 during PWRDN = 1, or within the 10 ms internal stabilization / reset time, it will not be taken into account and the card interface will remain inactive. Since Start/Stop is taken into account on its edges, it should be toggled low and high again after the 10 ms to activate a card.

Figure 5 illustrates the sequencing of the PD and Normal modes. PWRDN must be connected to GND if the power down function is not used.

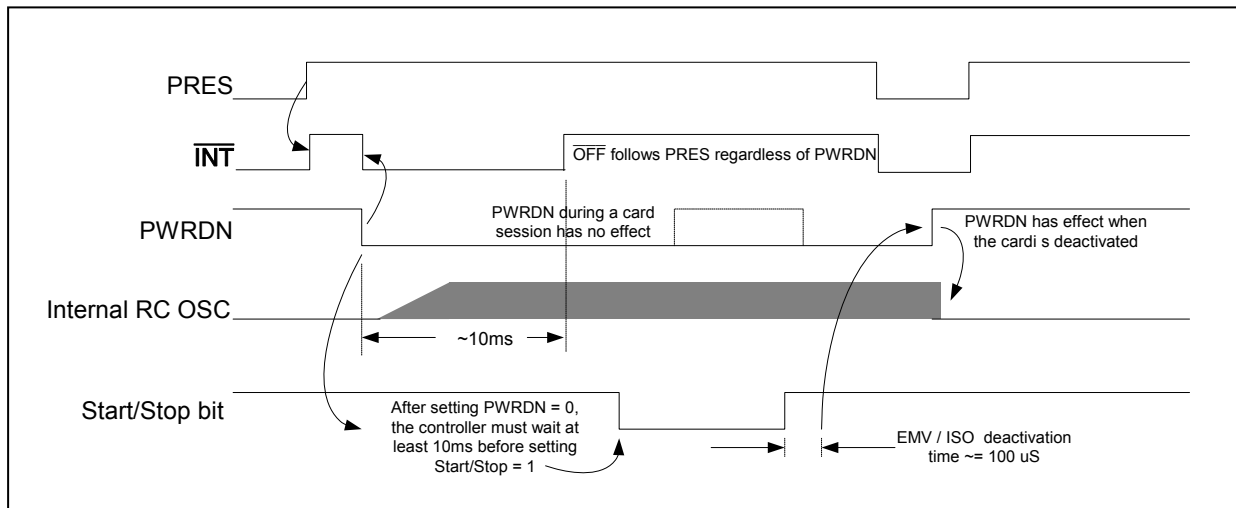

Figure 5: Power Down Mode Operation

7 Over-temperature Monitor

A built-in detector monitors die temperature. When an over-temperature condition occurs (most likely resulting from a heavily loaded card interface, including short circuits), a card deactivation sequence is initiated, and a fault condition is reported to the system controller (bit 4 of the status register is set and generates an interrupt).

8 Activation Sequence

After Power on Reset, the $\overline{\text{INT}}$ signal is low until V_{DD} is stable. When V_{DD} has been stable for approximately 10 ms and the $\overline{\text{INT}}$ signal is high, the system controller may read the status register to see if the card is present. If all the status bits are satisfactory, the system controller can initiate the activation sequence by writing a '1' to the Start/Stop bit (bit 0 of the Control register).

The following steps and Figure 6 show the activation sequence and the timing of the card control signals when the system controller initiates the Start/Stop bit (bit 0) of the control register:

1. Voltage V_{CC} to the card should be valid by the end of t_1 . If V_{CC} is not valid for any reason, then the session is aborted.
2. Turn I/O to reception mode at the end of t_1 .
3. CLK is applied to the card at the end of t_2 .
4. RST (to the card) is set high at the end of t_3 .

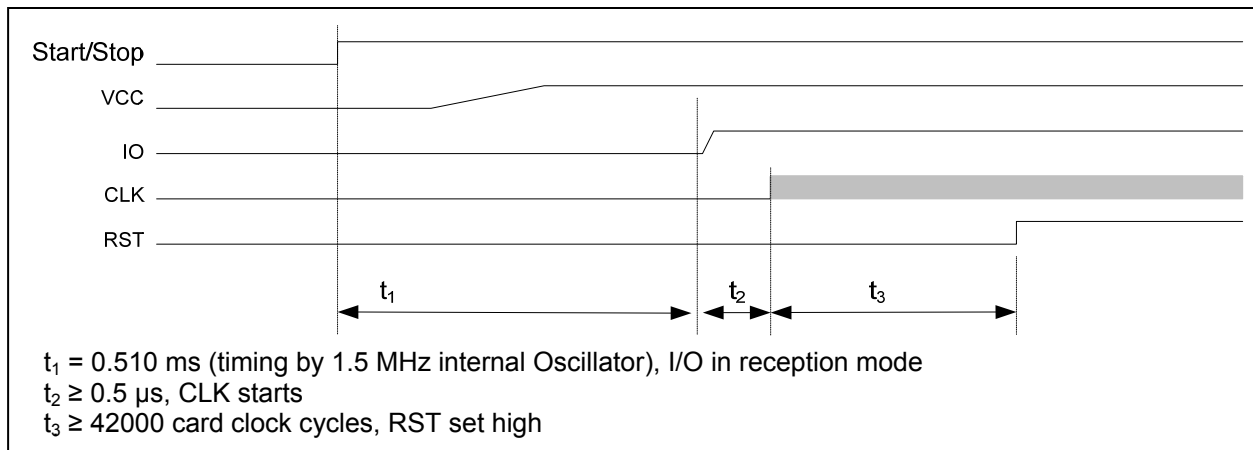

Figure 6: Activation Sequence

9 Deactivation Sequence

Deactivation is initiated either by the system controller resetting the Start/Stop bit, or automatically in the event of hardware faults. Hardware faults are over-current, over-temperature, V_{DD} fault, V_{CC} fault, and card extraction during the session.

The following steps and [Figure 7](#) show the deactivation sequence and the timing of the card control signals when the system controller clears the Start/Stop bit:

1. RST goes low at the end of t_1 .
2. CLK goes low at the end of t_2 .
3. I/O goes low at the end of t_3 . Out of reception mode.
4. Shut down V_{CC} at the end of time t_4 .

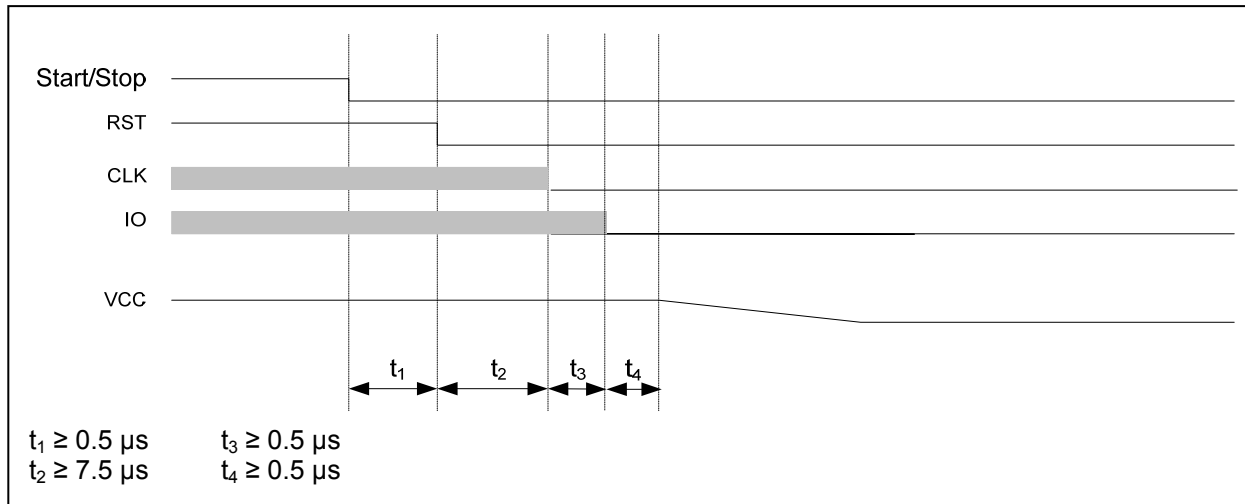

Figure 7: Deactivation Sequence

10 Interrupt

The interrupt is an active low interrupt. It is set low if either a V_{CC} fault or a V_{DD} fault is detected. It is also set low if one of the following status bit conditions is detected:

- Early ATR
- Mute ATR
- Card insert or card extract
- Protection status from Over-current or Over-heating

If the interrupt is set low by the detection of these status bits, then the interrupt is set high when these status bits are read. (READ STATUS DONE)

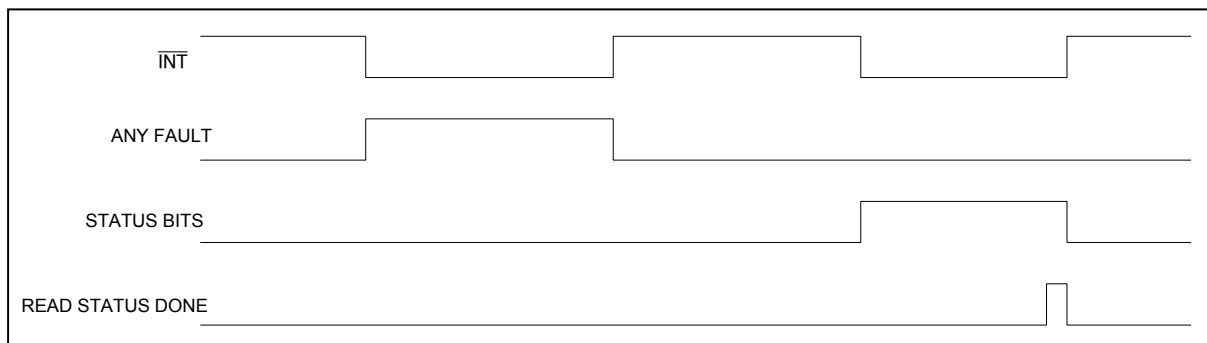

Figure 8: FAULT Functions, $\overline{\text{INT}}$ operation

A power-on-reset (POR) event will reset all of the control and status registers to their default states. A V_{DD} fault event does not reset these registers, but it will signal an interrupt condition and by the action of the timer that creates interval “ t_1 ,” will not clear the interrupt until V_{DD} is valid for at least the t_1 time. The V_{DD} fault can be considered valid for V_{DD} as low as 1.5 to 1.8 volts. At the lower range of the V_{DD} fault, POR will be asserted.

11 Warm Reset

The 73S8010C automatically asserts a warm reset to the card when instructed through bit 1 of the I²C Control register (Warm Reset bit). The warm reset length is automatically defined as 42,000 card clock cycles. The bit Warm Reset is automatically reset when the card starts answering or when the card is declared mute.

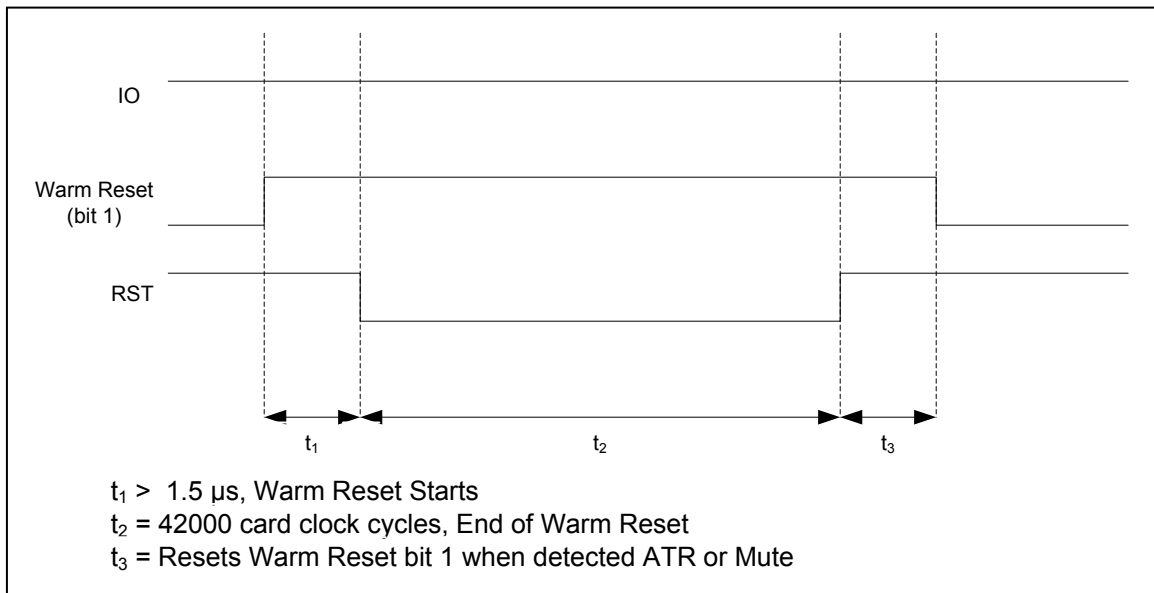

Figure 9: Warm Reset operation

12 I/O Timing

The states of the I/O, AUX1, and AUX2 pins are low after power on reset and they are high when the activation sequencer turns on the I/O reception state. See [Section 8 Activation Sequence](#) for more details on when the I/O reception is enabled.

The states of I/OUC, AUX1UC, and AUX2UC are high after power on reset. When the control I/O enable bit (bit 7 of the Control register) is set, the first I/O line on which a falling edge is detected becomes the input I/O line and the other becomes the output I/O line. When the input I/O line rising edge is detected then both I/O lines return to their neutral state. The delay between the I/O signals is shown in [Figure 10](#).

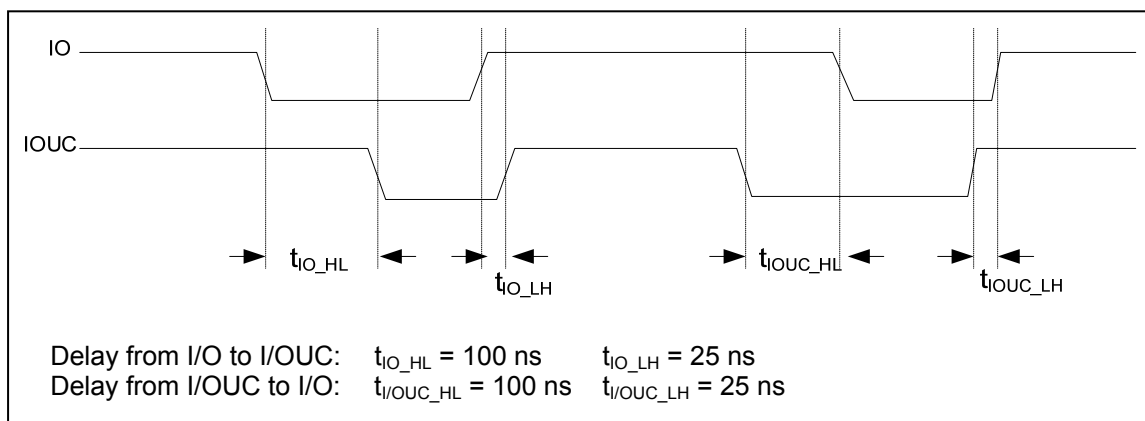

Figure 10: I/O Timing

14 Electrical Specification

14.1 Absolute Maximum Ratings



Operation outside these rating limits may cause permanent damage to the device.

| Parameter | Rating |
|---|--------------------------------|
| Supply Voltage V_{DD} | -0.5 to 4.0 VDC |
| Input Voltage for Digital Inputs | -0.3 to ($V_{DD} + 0.5$) VDC |
| Storage Temperature | -60 °C to 150 °C |
| Pin Voltage (except LIN and card interface) | -0.3 to ($V_{DD} + 0.5$) VDC |
| Pin Voltage (LIN) | -0.3 to 6.0 VDC |
| Pin Voltage (card interface) | -0.3 to ($V_{CC} + 0.5$) VDC |
| ESD Tolerance – Card interface pins | +/- 6 kV |
| ESD Tolerance – Other pins | +/- 2 kV |



ESD testing on Card pins uses the HBM condition, 3 pulses, each polarity referenced to ground.

14.2 Recommended Operating Conditions

| Parameter | Rating |
|----------------------------------|-------------------------|
| Supply Voltage V_{DD} | 2.7 to 3.6 VDC |
| Ambient Operating Temperature | -40 °C to +85 °C |
| Input Voltage for Digital Inputs | 0 V to $V_{DD} + 0.3$ V |

14.3 DC Characteristics: Card Interface

| Symbol | Parameter | Condition | Min. | Typ. | Max. | Unit |
|---|--|--|------|------|------|------------------|
| Card Power Supply (V_{CC}) DC-DC Converter | | | | | | |
| General conditions, $-40\text{ }^{\circ}\text{C} < T < 85\text{ }^{\circ}\text{C}$, $2.7\text{ V} < V_{DD} < 3.6\text{ V}$ | | | | | | |
| V_{CC} | Card supply voltage including ripple and noise | Inactive mode | -0.1 | | 0.1 | V |
| | | Inactive mode $I_{CC} = 1\text{ mA}$ | -0.1 | | 0.4 | V |
| | | Active mode $I_{CC} < 65\text{ mA}$; 5 V | 4.75 | | 5.25 | V |
| | | Active mode $I_{CC} < 65\text{ mA}$; 3 V | 2.8 | | 3.2 | V |
| | | Active mode single pulse of 100 mA for 2 μs ; 5 V, fixed load = 25 mA | 4.6 | | 5.25 | V |
| | | Active mode single pulse of 100 mA for 2 μs ; 3 V, fixed load = 25 mA | 2.76 | | 3.2 | V |
| | | Active mode current pulses of 40 nAs with peak $ I_{CC} < 200\text{ mA}$, $t < 400\text{ ns}$; 5 V | 4.6 | | 5.25 | V |
| | | Active mode current pulses of 40 nAs with peak $ I_{CC} < 200\text{ mA}$, $t < 400\text{ ns}$; 3 V | 2.76 | | 3.2 | V |
| I_{CCmax} | Maximum supply current to the card | Static load current, $V_{CC} > 4.6$ or 2.7 V as selected, $L=10\text{ }\mu\text{H}$ | 100 | | | mA |
| I_{CCF} | I_{CC} fault current | Short circuit, V_{CC} to ground | 100 | 125 | 180 | mA |
| V_{SR} | V_{CC} slew rate - Rise rate on activate | C_F on $V_{CC} = 1\text{ }\mu\text{F}$ | 0.05 | 0.15 | 0.25 | V/ μs |
| V_{SF} | V_{CC} slew rate - Fall rate on deactivate | C_F on $V_{CC} = 1\text{ }\mu\text{F}$ | 0.1 | 0.3 | 0.5 | V/ μs |
| C_F | External filter capacitor (V_{CC} to GND) | | 0.47 | 1 | 3.3 | μF |
| L | Inductor (LIN to V_{DD}) | | | 10 | | μH |
| I_{limax} | I_{max} in inductor | $V_{CC} = 5\text{ V}$, $I_{CC} = 65\text{ mA}$, $V_{DD} = 2.7\text{ V}$ | | | 400 | mA |
| η | Efficiency | $V_{CC} = 5\text{ V}$, $I_{CC} = 65\text{ mA}$, $V_{DD} = 3.3\text{ V}$ | | 87 | | % |

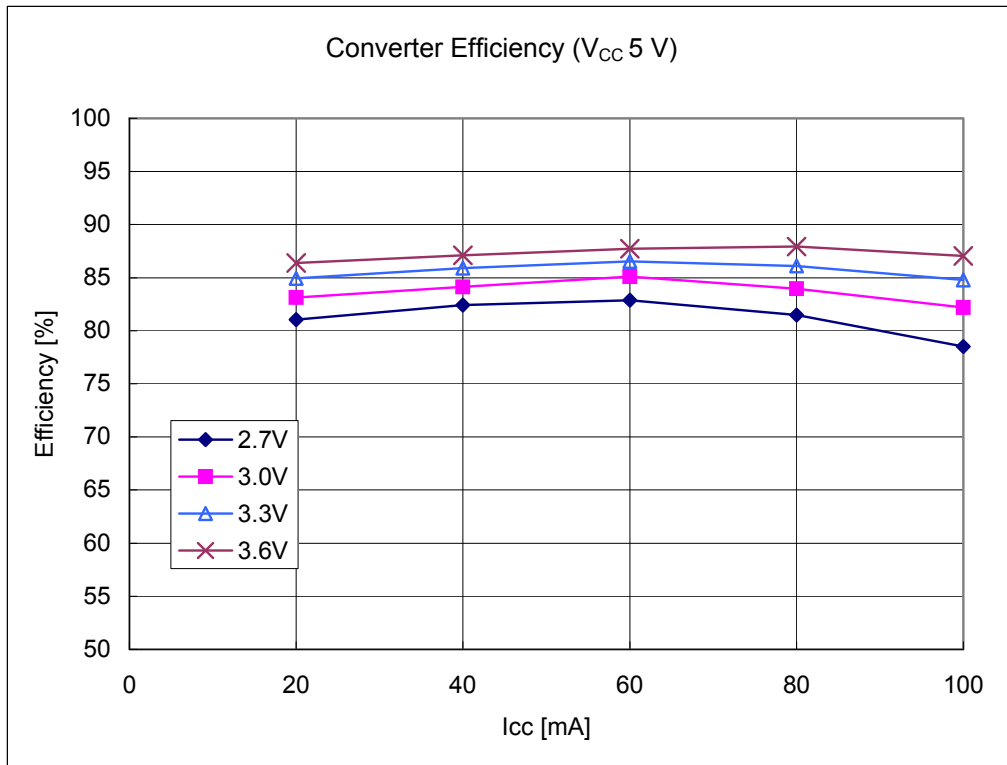

Figure 12: DC – DC Converter Efficiency (V_{CC} = 5 V)
 Output current on V_{CC} at 5 V. Input voltage on V_{DD} at 2.7, 3.0, 3.3 and 3.6 volts.

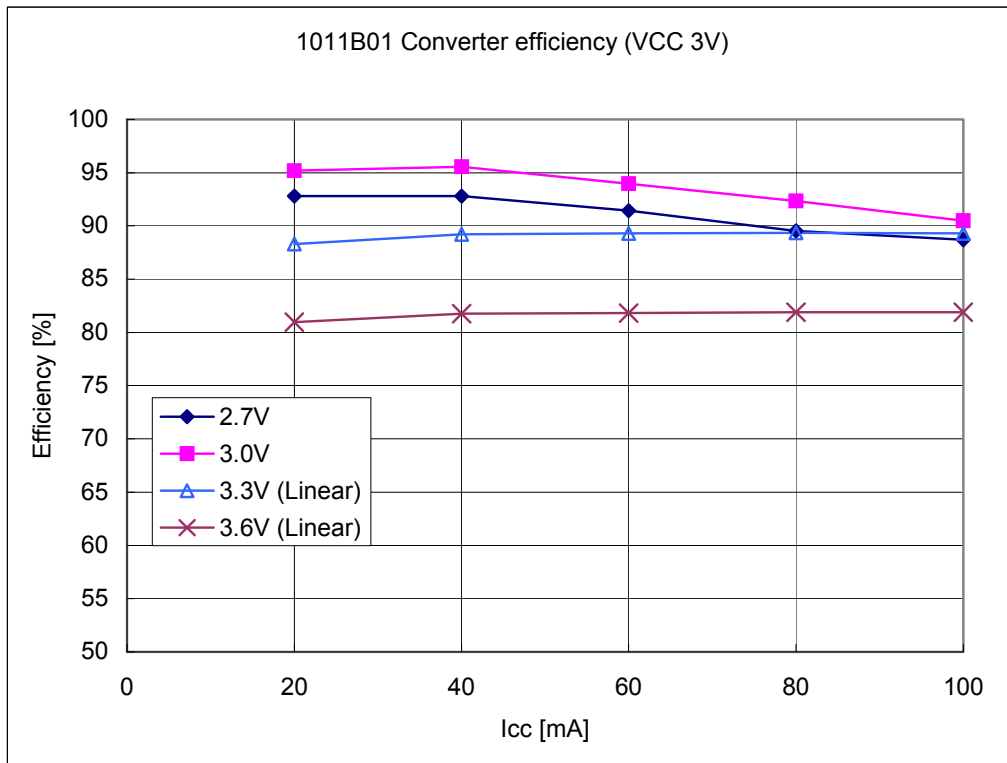

Figure 13: DC – DC Converter Efficiency (V_{CC} = 3 V)
 Output current on V_{CC} at 3 V. Input voltage on V_{DD} at 2.7, 3.0, 3.3 and 3.6 volts.

| Symbol | Parameter | Condition | Min. | Typ. | Max. | Unit |
|---|--|--|---------------|------|-----------------|------------|
| Interface Requirements – Data Signals: I/O, AUX1, AUX2, and host interfaces: I/OUC, AUX1UC, AUX2UC. I_{SHORTL} , I_{SHORTH} , and V_{INACT} requirements do not pertain to I/OUC, AUX1UC, and AUX2UC. I_{IL} requirements only pertain to I/OUC, AUX1UC, and AUX2UC. | | | | | | |
| V_{OH} | Output level, high (I/O, AUX1, AUX2) | $I_{OH} = 0$ | $0.9 V_{CC}$ | | $V_{CC} + 0.1$ | V |
| | | $I_{OH} = -40 \mu A$ | $0.75 V_{CC}$ | | $V_{CC} + 0.1$ | V |
| V_{OH} | Output level, high (I/OUC, AUX1UC, AUX2UC) | $I_{OH} = 0$ | $0.9 V_{DD}$ | | $V_{DD} + 0.1$ | V |
| | | $I_{OH} = -40 \mu A$ | $0.75 V_{DD}$ | | $V_{DD} + 0.1$ | V |
| V_{OL} | Output level, low | $I_{OL} = 1 \text{ mA}$ | | | 0.3 | V |
| V_{IH} | Input level, high (I/O, AUX1, AUX2) | | 1.8 | | $V_{CC} + 0.30$ | V |
| V_{IH} | Input level, high (I/OUC, AUX1UC, AUX2UC) | | 1.8 | | $V_{DD} + 0.30$ | V |
| V_{IL} | Input level, low | | -0.3 | | 0.8 | V |
| V_{INACT} | Output voltage when outside of session | $I_{OL} = 0$ | | | 0.1 | V |
| | | $I_{OL} = 1 \text{ mA}$ | | | 0.3 | V |
| I_{LEAK} | Input leakage | $V_{IH} = V_{CC}$ | | | 10 | μA |
| I_{IL} | Input current, low | $V_{IL} = 0, CS = 1$ | | | 0.65 | mA |
| | | $V_{IL} = 0, CS = 0$ | | | 5 | μA |
| I_{SHORTL} | Short circuit output current | For output low, shorted to V_{CC} through 33Ω | | | 15 | mA |
| I_{SHORTH} | Short circuit output current | For output high, shorted to ground through 33Ω | | | 15 | mA |
| t_R, t_F | Output rise time, fall times | For I/O, AUX1, AUX2, $C_L = 80 \text{ pF}$, 10% to 90% For I/OUC, AUX1UC, AUX2UC, $C_L = 50 \text{ pF}$, 10% to 90% | | | 100 | ns |
| t_{IR}, t_{IF} | Input rise, fall times | | | | 1 | μs |
| R_{PU} | Internal pull-up resistor | Output stable for >200 ns | 8 | 11 | 14 | k Ω |
| FD_{MAX} | Maximum data rate | | | | 1 | MHz |
| T_{FDIO} | Delay, I/O to I/OUC, I/OUC to I/O | | | 20 | | ns |
| C_{IN} | Input capacitance | | | | 10 | pF |

| Symbol | Parameter | Condition | Min. | Typ. | Max. | Unit |
|---|--|---|---------------------|------|-----------------|------|
| Reset and Clock for card interface, RST, CLK | | | | | | |
| V _{OH} | Output level, high | I _{OH} = -200 μA | 0.9 V _{CC} | | V _{CC} | V |
| V _{OL} | Output level, low | I _{OL} = 200 μA | 0 | | 0.3 | V |
| V _{INACT} | Output voltage when outside of a session | I _{OL} = 0 | | | 0.1 | V |
| | | I _{OL} = 1 mA | | | 0.3 | V |
| I _{RST_LIM} | Output current limit, RST | | | | 30 | mA |
| I _{CLK_LIM} | Output current limit, CLK | | | | 70 | mA |
| t _R , t _F | Output rise time, fall time | C _L = 35 pF for CLK, 10% to 90% | | | 8 | ns |
| | | C _L = 200 pF for RST, 10% to 90% | | | 100 | ns |
| δ | Duty cycle for CLK, except for f=f _{XTAL} | C _L = 35 pF, F _{CLK} ≤ 20 MHz | 45 | | 55 | % |

14.4 DC Characteristics: Digital Signals

| Symbol | Parameter | Condition | Min. | Typ. | Max. | Unit |
|---|------------------------------------|--|------------------------|------|-----------------------|------|
| Digital I/O except for OSC I/O | | | | | | |
| V _{IL} | Input Low Voltage | | -0.3 | | 0.8 | V |
| V _{IH} | Input High Voltage | | 1.8 | | V _{DD} + 0.3 | V |
| V _{OL} | Output Low Voltage | I _{OL} = 2 mA | | | 0.45 | V |
| V _{OH} | Output High Voltage | I _{OH} = -1 mA | V _{DD} - 0.45 | | | V |
| R _{OUT} | Pull-up resistor, \overline{INT} | | | 20 | | kΩ |
| I _{IL1} | Input Leakage Current | GND < V _{IN} < V _{DD} | -5 | | 5 | μA |
| Oscillator (XTALIN) I/O Parameters | | | | | | |
| V _{ILXTAL} | Input Low Voltage - XTALIN | | -0.3 | | 0.3 V _{DD} | V |
| V _{IHXTAL} | Input High Voltage - XTALIN | | 0.7 V _{DD} | | V _{DD} +0.3 | V |
| I _{ILXTAL} | Input Current - XTALIN | GND < V _{IN} < V _{DD} | -30 | | 30 | μA |
| f _{MAX} | Max freq. Osc or external clock | | | | 27 | MHz |
| δ _{in} | External input duty cycle limit | t _{R/F} < 10% f _{IN} , 45% < δ _{CLK} < 55% | 48 | | 52 | % |

14.5 DC Characteristics: Supply

| Symbol | Parameter | Condition | Min. | Typ. | Max. | Unit |
|--------------------|--|---|------|------|------|------|
| I _{DD} | Supply Current on V _{DD} | Linear mode, ICC=0 I/O, AUX1, AUX2=high | | 4.9 | | mA |
| | | Step up mode, ICC=0 I/O, AUX1, AUX2=high | | 4.7 | | mA |
| I _{DD_PD} | Supply Current on V _{DD} in Power Down mode | PWRDN=1, Start/stop bit = 0 All digital inputs driven with a true logical 0 or 1 | | 0.11 | 2.5 | μA |

14.6 DC Characteristics: I²C Interface

| Symbol | Parameter | Condition | Min. | Typ. | Max. | Unit |
|-----------------|---|---|-------------------------|------|-----------------------|------|
| SDA, SCL | | | | | | |
| V _{IL} | Input Low Voltage | | -0.3 | | 0.3* V _{DD} | V |
| V _{IH} | Input High Voltage | | 0.7*V _{DD} | | V _{DD} + 0.3 | V |
| V _{OL} | Output Low Voltage | I _{OL} = 3 mA | | | 0.40 | V |
| C _{IN} | Pin capacitance | | | | 10 | pF |
| I _{IN} | Output High Voltage | I _{OH} = -1 mA | V _{DD} - 0.45 | | | V |
| T _F | Output fall time | C _L = 0 to 400 pF | 20 + 0.1*C _L | | 250 | ns |
| T _{SP} | Pulse width of spikes that are suppressed | Transition from valid logic level to opposite level | | | 50 | ns |

14.7 Voltage / Temperature Fault Detection Circuits

| Symbol | Parameter | Condition | Min. | Typ. | Max. | Unit |
|------------------|--|--------------------------------------|------|------|------|------|
| V _{DDF} | V _{DD} fault – V _{DD} Voltage supervisor threshold | No external resistor on VDDF_ADJ pin | 2.15 | | 2.4 | V |
| V _{CCF} | V _{CC} fault – V _{CC} Voltage supervisor threshold | V _{CC} = 5 V | 4.20 | | 4.6 | V |
| | | V _{CC} = 3 V | 2.5 | | 2.7 | V |
| T _F | Die over temperature fault | | 115 | | 145 | °C |

15 Mechanical Drawings

15.1 32-pin QFN

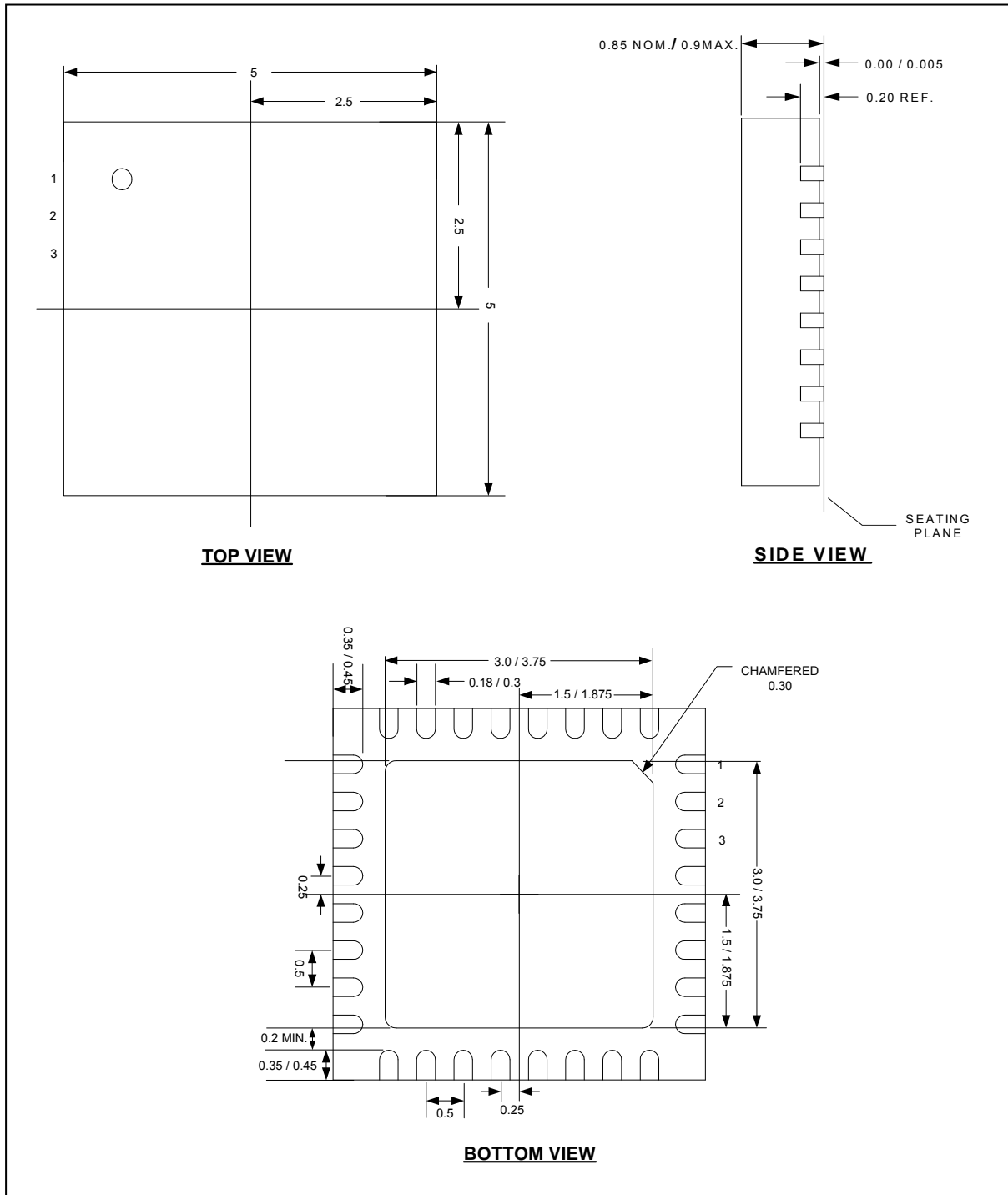

Figure 14: 32-pin QFN Package Drawing

15.2 28-pin SO

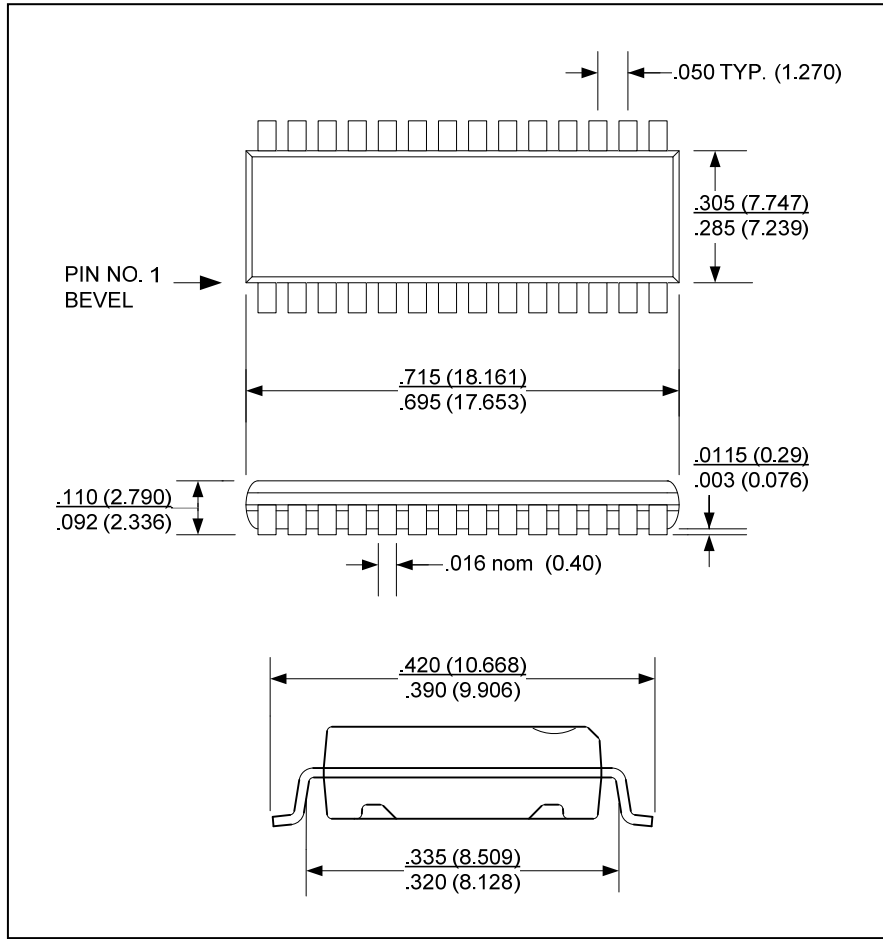

Figure 15: 28-pin SO Package Drawing

16 Package Pin Designation



Use handling procedures necessary for a static sensitive component.

16.1 32-pin QFN

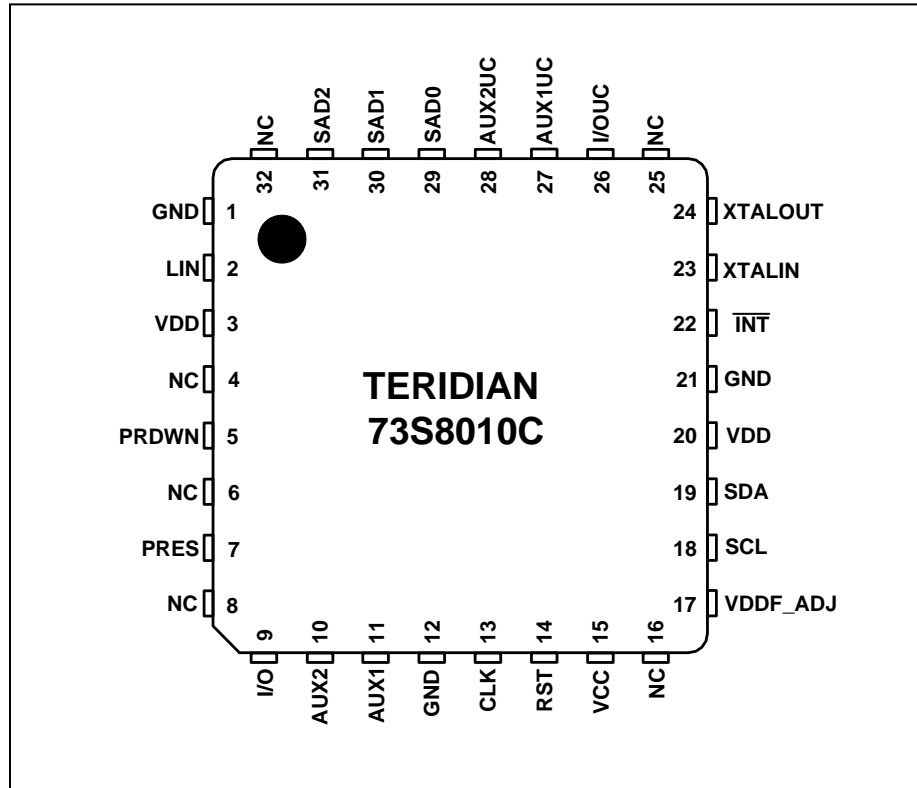

Figure 13: 73S8010C 32-pin QFN Pin Out
(Top View)

16.2 28-pin SO

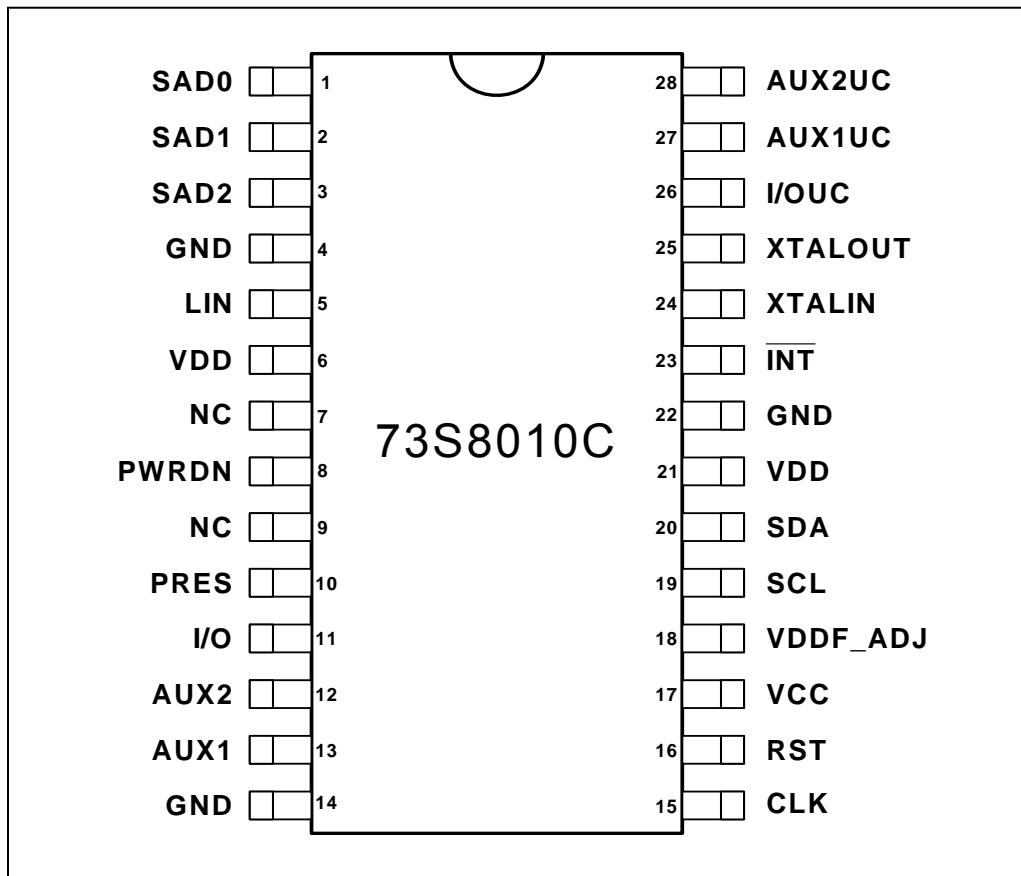

Figure 15: 73S8010C 28-pin SO Pin Out
(Top View)

17 Ordering Information

| Part Description | Order Number | Packaging Mark |
|---|----------------|----------------|
| 73S8010C-SO 28-pin Lead-Free SO | 73S8010C-IL/F | 73S8010C-IL |
| 73S8010C-SO 28-pin Lead-Free SO Tape / Reel | 73S8010C-ILR/F | 73S8010C-IL |
| 73S8010C-QFN 32-pin Lead-Free QFN | 73S8010C-IM/F | 73S8010C |
| 73S8010C-QFN 32-pin Lead-Free QFN Tape / Reel | 73S8010C-IMR/F | 73S8010C |

18 Related Documentation

The following 73S8010C documents are available from Teridian Semiconductor Corporation:

73S8010C Data Sheet (this document)
73S8010C 28SO Demo Board User's Guide
73S8010C QFN Demo Board User's Guide

19 Contact Information

For more information about Teridian Semiconductor products or to check the availability of the 73S8010C, contact us at:

6440 Oak Canyon Road
 Suite 100
 Irvine, CA 92618-5201

Telephone: (714) 508-8800
 FAX: (714) 508-8878
 Email: scr.support@teridian.com

For a complete list of worldwide sales offices, go to <http://www.teridian.com>.

Revision History

| Revision | Date | Description |
|----------|-----------|--|
| 1.0 | 6/13/2005 | First publication. |
| 1.2 | 9/21/2005 | Changed SDATA hold time. |
| 1.3 | 12/5/2007 | Added ISO and ENV logo, remove leaded package options, replace 32QFN punched with SAWN, update 28SO dimension. |
| 1.4 | 1/17/2008 | Changed dimension of bottom exposed pad on 32QFN mechanical package figure. |
| 1.5 | 4/3/2009 | Removed all references to VPC as VPC must be tied to VDD. |

© 2009 Teridian Semiconductor Corporation. All rights reserved.

Teridian Semiconductor Corporation is a registered trademark of Teridian Semiconductor Corporation.

Simplifying System Integration is a trademark of Teridian Semiconductor Corporation.

All other trademarks are the property of their respective owners.

Teridian Semiconductor Corporation makes no warranty for the use of its products, other than expressly contained in the Company's warranty detailed in the Teridian Semiconductor Corporation standard Terms and Conditions. The company assumes no responsibility for any errors which may appear in this document, reserves the right to change devices or specifications detailed herein at any time without notice and does not make any commitment to update the information contained herein. Accordingly, the reader is cautioned to verify that this document is current by comparing it to the latest version on <http://www.teridian.com> or by checking with your sales representative.

Teridian Semiconductor Corp., 6440 Oak Canyon Rd., Suite 100, Irvine, CA 92618
 TEL (714) 508-8800, FAX (714) 508-8877, <http://www.Teridian.com>

Looking for pricing, stock, or lifecycle information?

Click below to explore more details on WIN SOURCE:

 [View 73S8010C-IL/F on WIN SOURCE](#)

 [Maxim Integrated](#) Information

Optimize Your Supply Chain with WIN SOURCE Solutions

-  Global Sourcing Solution
-  Obsolete Management
-  Cost Control Management
-  Shortage Management
-  Alternative Solution
-  Excess Inventory Management