



THE DATASHEET OF
5V41067APGG8



2:4 PCIE GEN1/2/3 CLOCK MULTIPLEXER

IDT5V41067A

Description

The IDT5V41067A is a 2:4 differential clock mux for PCI Express applications. It has very low additive jitter making it suitable for use in PCIe Gen2 and Gen3 systems. The IDT5V41067A selects between 1 of 2 differential HCSL inputs to fanout to 4 differential HCSL output pairs. The outputs can also be terminated to LVDS.

Recommended Applications

- Clock muxing in PCIe Gen2 and Gen3 applications

Output Features

- 4 – 0.7V current mode differential HCSL output pairs

Features/Benefits

- Low additive jitter; suitable for use in PCIe Gen2 and Gen3 systems
- 20-pin TSSOP package; small board footprint
- Outputs can be terminated to LVDS; can drive a wider variety of devices
- OE control pin; greater system power management
- Industrial temperature range available; supports demanding embedded applications

Key Specifications

- Additive cycle-to-cycle jitter <5 ps
- Additive phase jitter (PCIe Gen2/3) <0.2ps
- Operating frequency up to 200MHz

Block Diagram

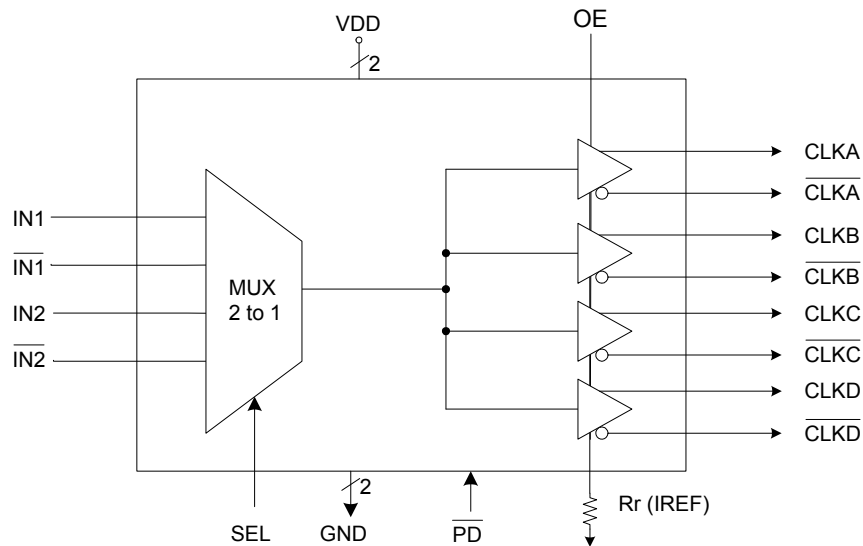

Pin Assignment

^SEL	1	20	DIF_0
VDDIN	2	19	DIF_0#
DIF_IN1	3	18	DIF_1
DIF_IN1#	4	17	DIF_1#
^PD#	5	16	GND
DIF_IN2	6	15	VDD
DIF_IN2#	7	14	DIF_2
^OE	8	13	DIF_2#
GND	9	12	DIF_3
IREF	10	11	DIF_3#

Note: Pins preceded by **^ have internal
120K ohm pull up resistors
20-pin (173mil) TSSOP

Select Table

SEL	Outputs
0	DIF_IN2
1	DIF_IN1

Pin Descriptions

PIN #	PIN NAME	PIN TYPE	DESCRIPTION
1	^SEL	IN	Selects between one of two inputs. This pin has internal pull up resistor.
2	VDDIN	PWR	Power pin for the Inputs, nominal 3.3V
3	DIF_IN1	IN	0.7 V Differential TRUE input
4	DIF_IN1#	IN	0.7 V Differential Complementary Input
5	^PD#	IN	Asynchronous active low input pin used to power down the device. The internal clocks are disabled and the VCO and the crystal osc. (if any) are stopped.
6	DIF_IN2	IN	0.7 V Differential TRUE input
7	DIF_IN2#	IN	0.7 V Differential Complementary Input
8	^OE	IN	Active high input for enabling outputs. This pin has an internal pull up resistor. 0 = disable outputs, 1= enable outputs
9	GND	PWR	Ground pin.
10	IREF	OUT	This pin establishes the reference for the differential current-mode output pairs. It requires a fixed precision resistor to ground. 475ohm is the standard value for 100ohm differential impedance. Other impedances require different values. See data sheet.
11	DIF_3#	OUT	0.7V differential Complementary clock output
12	DIF_3	OUT	0.7V differential true clock output
13	DIF_2#	OUT	0.7V differential Complementary clock output
14	DIF_2	OUT	0.7V differential true clock output
15	VDD	PWR	Power supply, nominal 3.3V
16	GND	PWR	Ground pin.
17	DIF_1#	OUT	0.7V differential Complementary clock output
18	DIF_1	OUT	0.7V differential true clock output
19	DIF_0#	OUT	0.7V differential Complementary clock output
20	DIF_0	OUT	0.7V differential true clock output

Application Information

Decoupling Capacitors

As with any high-performance mixed-signal IC, the IDT5V41067A must be isolated from system power supply noise to perform optimally.

Decoupling capacitors of 0.01 μ F must be connected between each VDD and the PCB ground plane.

PCB Layout Recommendations

For optimum device performance and lowest output phase noise, the following guidelines should be observed.

Each 0.01 μ F decoupling capacitor should be mounted on the component side of the board as close to the VDD pin as possible. No vias should be used between decoupling capacitor and VDD pin. The PCB trace to VDD pin should be kept as short as possible, as should the PCB trace to the ground via. Distance of the ferrite bead and bulk decoupling from the device is less critical.

2) An optimum layout is one with all components on the same side of the board, minimizing vias through other signal layers (the ferrite bead and bulk decoupling capacitor can be mounted on the back). Other signal traces should be routed away from the IDT5V41067A.

This includes signal traces just underneath the device, or on layers adjacent to the ground plane layer used by the device.

External Components

A minimum number of external components are required for proper operation. Decoupling capacitors of 0.01 μ F should be connected between VDD and GND pairs (2,9 and 15,16) as close to the device as possible.

Current Reference Source R_r (I_{ref})

If board target trace impedance (Z) is 50 Ω , then $R_r = 475\Omega$ (1%), providing IREF of 2.32 mA, output current (I_{OH}) is equal to 6*IREF.

Load Resistors R_L

Since the clock outputs are open source outputs, 50 ohm external resistors to ground are to be connected at each clock output.

Output Termination

The PCI-Express differential clock outputs of the IDT5V41067A are open source drivers and require an external series resistor and a resistor to ground. These resistor values and their allowable locations are shown in detail in the **Layout Guidelines** section.

The IDT5V41067A can also be terminated to LVDS compatible voltage levels. See the **Layout Guidelines** section.

Output Structures

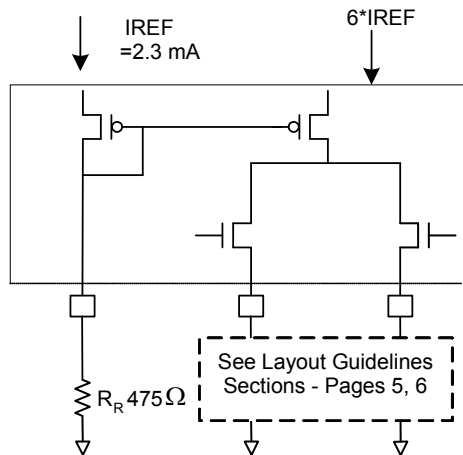

General PCB Layout Recommendations

For optimum device performance and lowest output phase noise, the following guidelines should be observed.

1. Each $0.01 \mu\text{F}$ decoupling capacitor should be mounted on the component side of the board as close to the VDD pin as possible.
2. No vias should be used between decoupling capacitor and VDD pin.
3. The PCB trace to VDD pin should be kept as short as possible, as should the PCB trace to the ground via. Distance of the ferrite bead and bulk decoupling from the device is less critical.
4. An optimum layout is one with all components on the same side of the board, minimizing vias through other signal layers (any ferrite beads and bulk decoupling capacitors can be mounted on the back). Other signal traces should be routed away from the IDT5V41067A. This includes signal traces just underneath the device, or on layers adjacent to the ground plane layer used by the device.

Layout Guidelines

PCIe (SRC) Reference Clock			
Common Recommendations for Differential Routing	Dimension or Value	Unit	Figure
L1 length, route as non-coupled 50ohm trace	0.5 max	inch	1
L2 length, route as non-coupled 50ohm trace	0.2 max	inch	1
L3 length, route as non-coupled 50ohm trace	0.2 max	inch	1
Rs	33	ohm	1
Rt	49.9	ohm	1

Down Device Differential Routing			
L4 length, route as coupled microstrip 100ohm differential trace	2 min to 16 max	inch	1
L4 length, route as coupled stripline 100ohm differential trace	1.8 min to 14.4 max	inch	1

Differential Routing to PCI Express Connector			
L4 length, route as coupled microstrip 100ohm differential trace	0.25 to 14 max	inch	2
L4 length, route as coupled stripline 100ohm differential trace	0.225 min to 12.6 max	inch	2

Figure 1: Down Device Routing

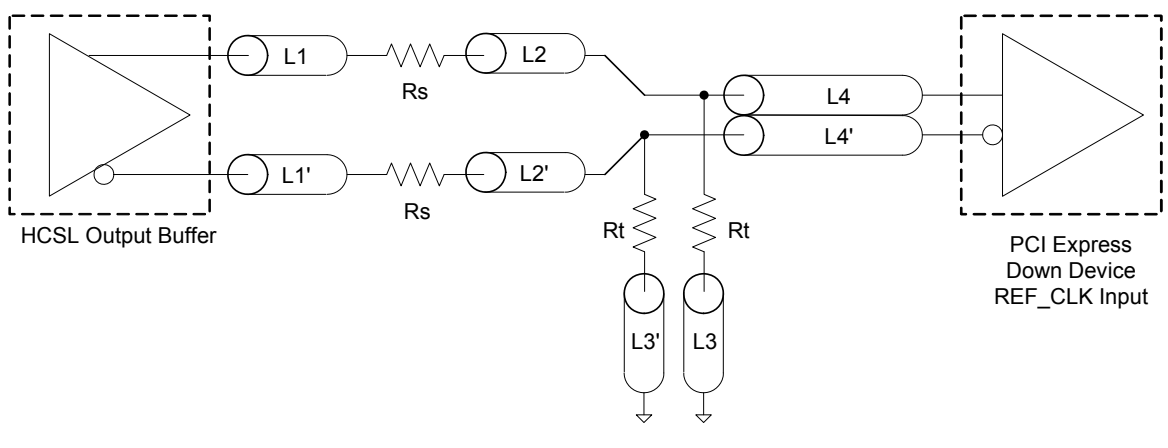
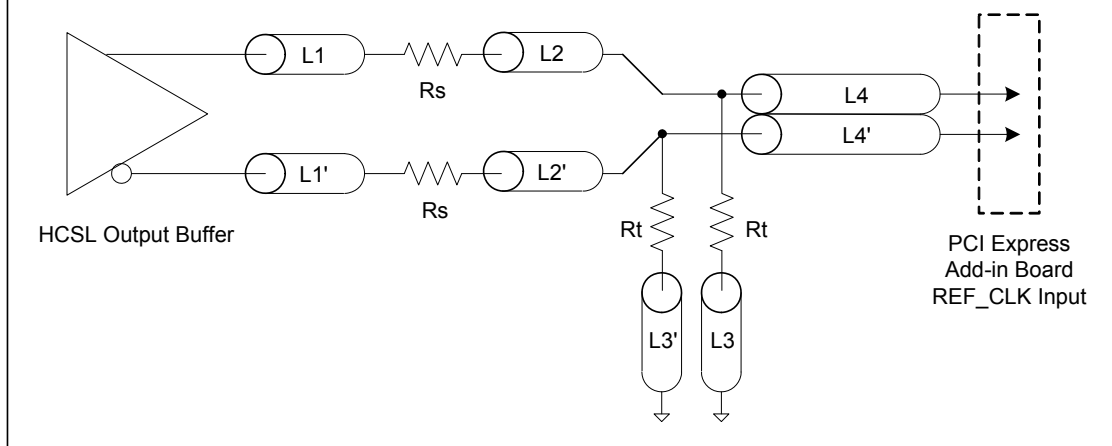
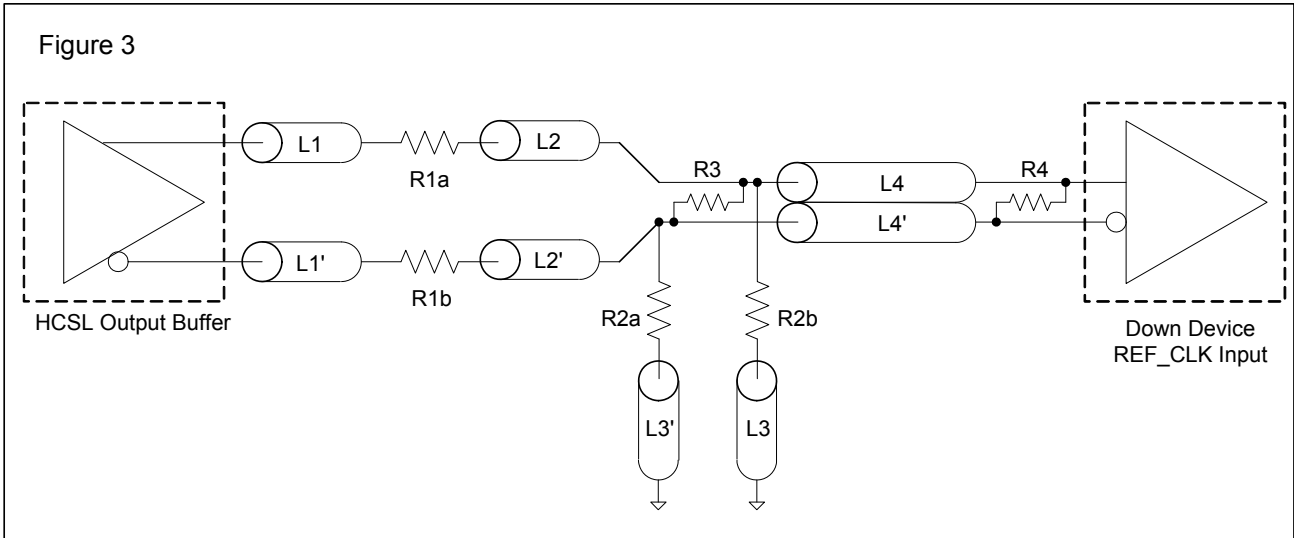

Figure 2: PCI Express Connector Routing



Alternative Termination for LVDS and other Common Differential Signals (figure 3)							
Vdiff	Vp-p	Vcm	R1	R2	R3	R4	Note
0.45v	0.22v	1.08	33	150	100	100	
0.58	0.28	0.6	33	78.7	137	100	
0.80	0.40	0.6	33	78.7	none	100	ICS874003i-02 input compatible
0.60	0.3	1.2	33	174	140	100	Standard LVDS

R1a = R1b = R1
R2a = R2b = R2



Cable Connected AC Coupled Application (figure 4)		
Component	Value	Note
R5a, R5b	8.2K 5%	
R6a, R6b	1K 5%	
Cc	0.1 μ F	
Vcm	0.350 volts	

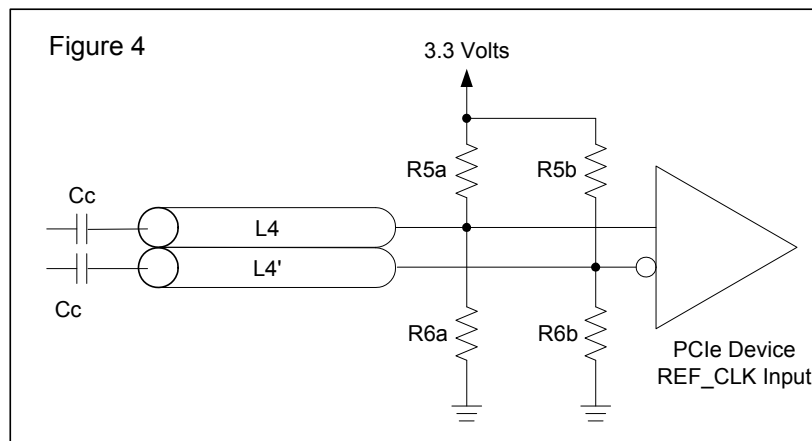

Absolute Maximum Ratings

Stresses above the ratings listed below can cause permanent damage to the IDT5V41067A. These ratings, which are standard values for IDT commercially rated parts, are stress ratings only. Functional operation of the device at these or any other conditions above those indicated in the operational sections of the specifications is not implied. Exposure to absolute maximum rating conditions for extended periods can affect product reliability. Electrical parameters are guaranteed only over the recommended operating temperature range.

PARAMETER	SYMBOL	CONDITIONS	MIN	TYP	MAX	UNITS	NOTES
3.3V Logic Supply Voltage	VDD				4.6	V	1,2
Input Low Voltage	V _{IL}		GND-0.5			V	1
Input High Voltage	V _{IH}				V _{DD} +0.5V	V	1
Storage Temperature	T _s		-65		150	°C	1
Junction Temperature	T _j				125	°C	1
Input ESD protection	ESD prot	Human Body Model	2000			V	1

¹Guaranteed by design and characterization, not 100% tested in production.

²Operation under these conditions is neither implied nor guaranteed.

Electrical Characteristics—Input/Supply/Common Parameters

TA = T_{COM} or T_{IND}; Supply Voltage VDD/VDDA = 3.3 V +/-5%, See Test Loads for Loading Conditions

PARAMETER	SYMBOL	CONDITIONS	MIN	TYP	MAX	UNITS	NOTES
Ambient Operating Temperature	T _{COM}	Commercial range	0		70	°C	1
	T _{IND}	Industrial range	-40		85	°C	1
Input High Voltage	V _{IH}	Single-ended inputs, <i>except</i> SMBus, low threshold and tri-level inputs, if present	2.2		V _{DD} + 0.3	V	1
Input Low Voltage	V _{IL}	Single-ended inputs, <i>except</i> SMBus, low threshold and tri-level inputs, if present	GND - 0.3		0.8	V	1
Input Current	I _{IN}	Single-ended inputs, V _{IN} = GND, V _{IN} = VDD	-5		5	uA	1
	I _{INP}	Single-ended inputs V _{IN} = 0 V; Inputs with internal pull-up resistors V _{IN} = VDD; Inputs with internal pull-down resistors	-200		200	uA	1
Input Frequency	F _{ibyp}	V _{DD} = 3.3 V, Bypass mode			200	MHz	2
Pin Inductance	L _{bin}				7	nH	1
Capacitance	C _{IN}	Logic Inputs, <i>except</i> DIF_IN	1.5		5	pF	1
	C _{INDIF_IN}	Differential clock inputs	1.5		2.7	pF	1,4
	C _{OUT}	Output pin capacitance			6	pF	1
OE Latency	t _{LATOE#}	DIF start after OE# assertion DIF stop after OE# deassertion	1		3	clocks	1,3,5
PD# Latency	t _{STABPD#}	DIF driven to 200mV after PDE# assertion			300	usec	1,3,5
T _{fall}	t _F	Fall time of control inputs			5	ns	1,2
T _{rise}	t _R	Rise time of control inputs			5	ns	1,2

¹Guaranteed by design and characterization, not 100% tested in production.

²Control input must be monotonic from 20% to 80% of input swing.

³Time from deassertion until outputs are >200 mV

⁴INAB inputs

⁵The differential input clock must be running for the OE pin to work

Electrical Characteristics–Clock Input Parameters

TA = T_{COM} or T_{IND}; Supply Voltage VDD/VDDA = 3.3 V +/-5%, See Test Loads for Loading Conditions

PARAMETER	SYMBOL	CONDITIONS	MIN	TYP	MAX	UNITS	NOTES
Input High Voltage - DIF_IN	V _{IHDIF}	Differential inputs (single-ended measurement)	600	800	1150	mV	1
Input Low Voltage - DIF_IN	V _{ILDIF}	Differential inputs (single-ended measurement)	V _{SS} - 300	0	300	mV	1
Input Common Mode Voltage - DIF_IN	V _{COM}	Common Mode Input Voltage	300		1000	mV	1
Input Amplitude - DIF_IN	V _{SWING}	Peak to Peak value	300		1450	mV	1
Input Slew Rate - DIF_IN	dv/dt	Measured differentially	1		8	V/ns	1,2
Input Leakage Current	I _{IN}	V _{IN} = V _{DD} , V _{IN} = GND	-5		5	uA	1
Input Duty Cycle	d _{in}	Measurement from differential waveform	45		55	%	1
Input Jitter - Cycle to Cycle	J _{DIFIn}	Differential Measurement	0		125	ps	1

¹ Guaranteed by design and characterization, not 100% tested in production.

² Slew rate measured through +/-75mV window centered around differential zero.

Electrical Characteristics–DIF 0.7V Current Mode Differential Outputs

TA = T_{COM} or T_{IND}; Supply Voltage VDD/VDDA = 3.3 V +/-5%, See Test Loads for Loading Conditions

PARAMETER	SYMBOL	CONDITIONS	MIN	TYP	MAX	UNITS	NOTES
Slew rate	T _{rf}	Scope averaging on	1.5	2.9	4	V/ns	1, 2, 3
Slew rate matching	ΔT _{rf}	Slew rate matching, Scope averaging on		14.4	20	%	1, 2, 4
Voltage High	V _{High}	Statistical measurement on single-ended signal using oscilloscope math function. (Scope averaging on)	660	761	850	mV	1
Voltage Low	V _{Low}		-150	0.6	150		1
Max Voltage	V _{max}	Measurement on single ended signal using absolute value. (Scope averaging off)		860	1150	mV	1
Min Voltage	V _{min}		-300	-78			1
V _{swing}	V _{swing}	Scope averaging off	300	1531		mV	1, 2
Crossing Voltage (abs)	V _{cross_abs}	Scope averaging off	250	354	550	mV	1, 5
Crossing Voltage (var)	ΔV _{cross}	Scope averaging off		36	140	mV	1, 6

¹ Guaranteed by design and characterization, not 100% tested in production. I_{REF} = VDD/(3xR_R). For R_R = 475Ω (1%), I_{REF} = 2.32mA. I_{OH} = 6 x I_{REF} and V_{OH} = 0.7V @ Z_O=50Ω (100Ω differential impedance).

² Measured from differential waveform

³ Slew rate is measured through the V_{swing} voltage range centered around differential 0V. This results in a +/-150mV window around differential 0V.

⁴ Matching applies to rising edge rate of Clock / falling edge rate of Clock#. It is measured in a +/-75mV window centered on the average cross point where Clock rising meets Clock# falling. The median cross point is used to calculate the voltage thresholds the oscilloscope uses for the edge rate calculations.

⁵ V_{cross} is defined as voltage where Clock = Clock# measured on a component test board and only applies to the differential rising edge (i.e. Clock rising and Clock# falling).

⁶ The total variation of all V_{cross} measurements in any particular system. Note that this is a subset of V_{cross_min/max} (V_{cross} absolute) allowed. The intent is to limit V_{cross} induced modulation by setting V_{cross_delta} to be smaller than V_{cross} absolute.

Electrical Characteristics–Current Consumption

TA = T_{COM} or T_{IND}; Supply Voltage VDD/VDDA = 3.3 V +/-5%, See Test Loads for Loading Conditions

PARAMETER	SYMBOL	CONDITIONS	MIN	TYP	MAX	UNITS	NOTES
Operating Supply Current	I _{DD3.3OP}	All outputs active @100MHz, C _L = 2pF;		80	85	mA	1
Power Down Current	I _{DD3.3PD}	PD# pin low, input clock stopped		4	5	mA	1

¹ Guaranteed by design and characterization, not 100% tested in production.

Electrical Characteristics–Output Duty Cycle, Jitter, and Skew Characteristics

TA = T_{COM} or T_{IND}; Supply Voltage VDD/VDDA = 3.3 V +/-5%, See Test Loads for Loading Conditions

PARAMETER	SYMBOL	CONDITIONS	MIN	TYP	MAX	UNITS	NOTES
Duty Cycle	t _{DC}	When driven by 932SQ420 or equivalent	45	49	55	%	1
Duty Cycle Distortion	t _{DCD}	Measured differentially, @100MHz	-2	1.3	2	%	1,4
Skew, Input to Output	t _{pdBYP}	V _T = 50%	2500	3300	4500	ps	1
Skew, Output to Output	t _{sk3}	V _T = 50%		37	50	ps	1
Additive Jitter	t _{cyc-cyc}	Cycle to cycle Additive Jitter		1.1	10	ps	1,3

¹ Guaranteed by design and characterization, not 100% tested in production.

² I_{REF} = V_{DD}/(3xR_R). For R_R = 475Ω (1%), I_{REF} = 2.32mA. I_{OH} = 6 x I_{REF} and V_{OH} = 0.7V @ Z_O=50Ω.

³ Measured from differential waveform

⁴ Duty cycle distortion is the difference in duty cycle between the output and the input clock when the device is operated in bypass mode.

Electrical Characteristics–PCIe Phase Jitter Parameter

TA = T_{COM} or T_{IND}; Supply Voltage VDD/VDDA = 3.3 V +/-5%, See Test Loads for Loading Conditions

PARAMETER	SYMBOL	CONDITIONS	MIN	TYP	MAX	UNITS	Notes
Additive Phase Jitter	t _{jphPCIeG1}	PCIe Gen 1		1	5	ps (p-p)	1,2,3,6
	t _{jphPCIeG2}	PCIe Gen 2 Lo Band 10kHz < f < 1.5MHz		0.1	0.2	ps (rms)	1,2,5,6
		PCIe Gen 2 High Band 1.5MHz < f < Nyquist (50MHz)		0.1	0.2	ps (rms)	1,2,5,6
	t _{jphPCIeG3}	PCIe Gen 3 (PLL BW of 2-4MHz, CDR = 10MHz)		0.1	0.2	ps (rms)	1,2,4,5,6

¹ Applies to all outputs.

² See <http://www.pcisig.com> for complete specs

³ Sample size of at least 100K cycles. This figures extrapolates to 108ps pk-pk @ 1M cycles for a BER of 1-12.

⁴ Subject to final radification by PCI SIG.

⁵ For RMS figures, additive jitter is calculated by solving the following equation: Additive jitter = SQRT[(total jitter)² - (input jitter)²]

⁶ Applies to 100MHz spread off and 0.5% down spread sources only.

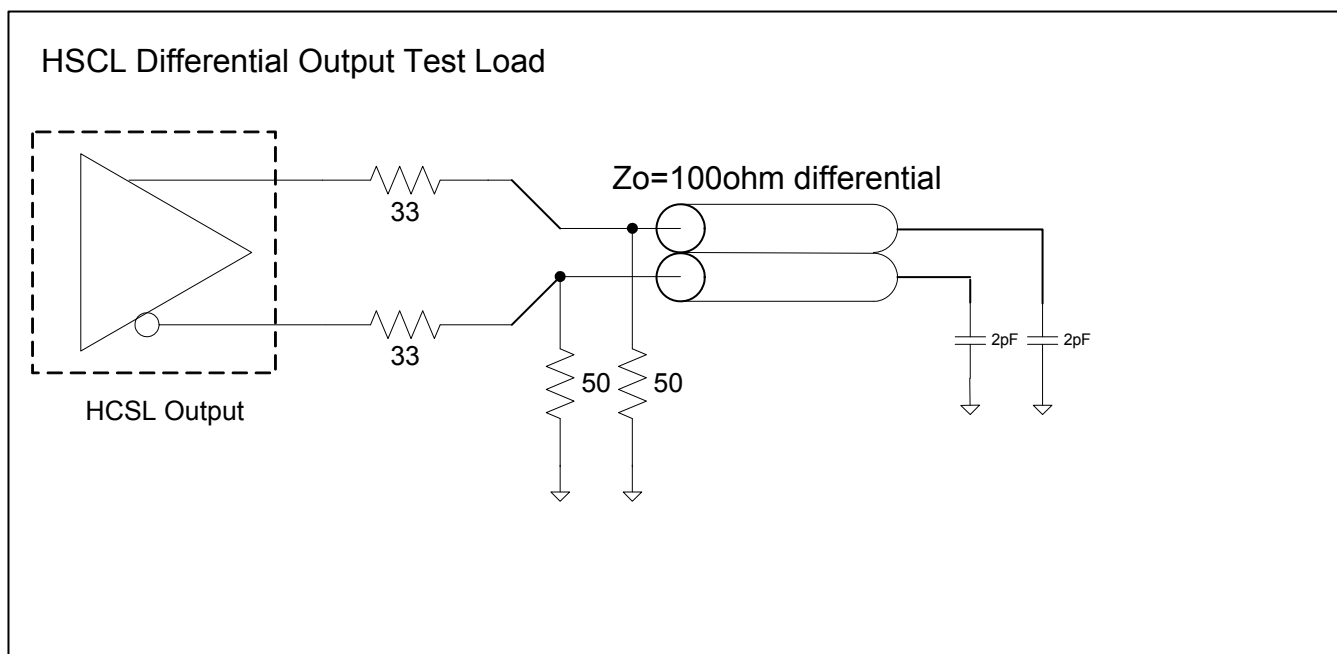

Thermal Characteristics

Parameter	Symbol	Conditions	Min.	Typ.	Max.	Units
Thermal Resistance Junction to Ambient	θ_{JA}	Still air		93		°C/W
	θ_{JA}	1 m/s air flow		78		°C/W
	θ_{JA}	3 m/s air flow		65		°C/W
Thermal Resistance Junction to Case	θ_{JC}			20		°C/W

Marking Diagram

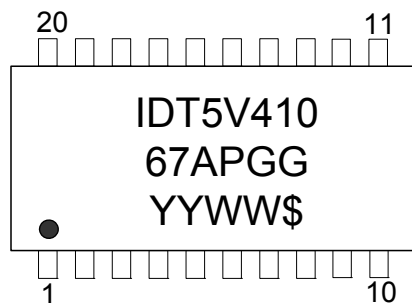

Marking Diagram (Industrial)

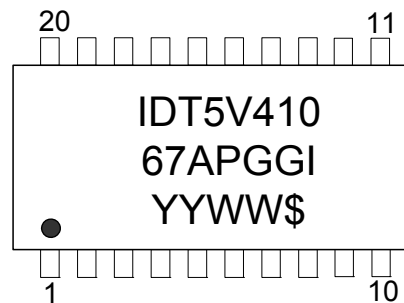

Notes:

1. \$ is the mark code.
2. YYWW is the last two digits of the year and week that the part was assembled.
3. "G" after the two-letter package code denotes RoHS compliant package.
4. "I" denotes industrial grade.
5. Bottom marking: country of origin if not USA.

Package Outline and Package Dimensions (20-pin TSSOP, 173 Mil. Narrow Body)

Package dimensions are kept current with JEDEC Publication No. 95

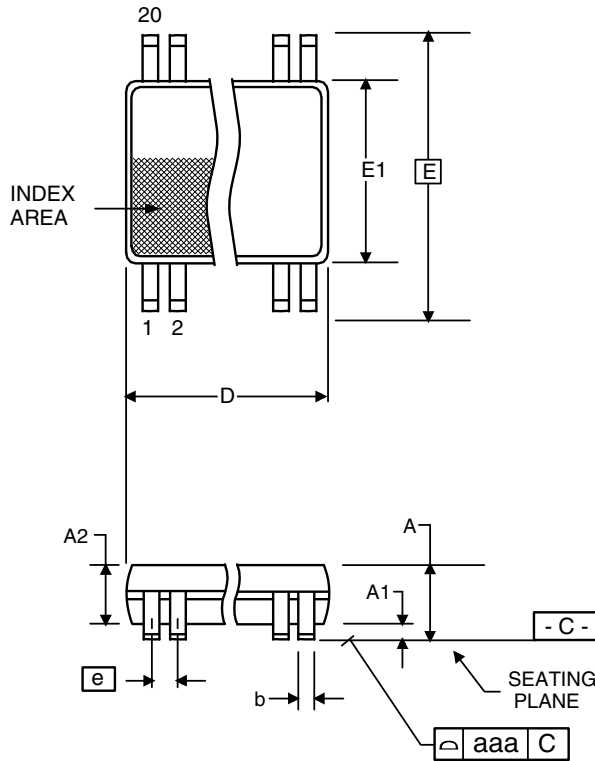

Symbol	Millimeters		Inches*	
	Min	Max	Min	Max
A		1.20		0.047
A1	0.05	0.15	0.002	0.006
A2	0.80	1.05	0.032	0.041
b	0.19	0.30	0.007	0.012
c	0.09	0.20	0.0035	0.008
D	6.40	6.60	0.252	0.260
E	6.40 BASIC		0.252 BASIC	
E1	4.30	4.50	0.169	0.177
e	0.65 Basic		0.0256 Basic	
L	0.45	0.75	0.018	0.030
a	0°	8°	0°	8°
aaa	--	0.10	--	0.004

*For reference only. Controlling dimensions in mm.

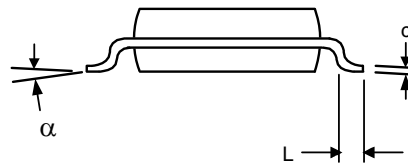

Ordering Information

Part / Order Number	Shipping Packaging	Package	Temperature
5V41067APGG	Tubes	20-pin TSSOP	0 to +70°C
5V41067APGG8	Tape and Reel	20-pin TSSOP	0 to +70°C
5V41067APGGI	Tubes	20-pin TSSOP	-40 to +85°C
5V41067APGGI8	Tape and Reel	20-pin TSSOP	-40 to +85°C

“G” after the two-letter package code are the Pb-Free configuration, RoHS compliant.

“A” is the device revision designer (will not correlate to the datasheet revision).

While the information presented herein has been checked for both accuracy and reliability, Integrated Device Technology (IDT) assumes no responsibility for either its use or for the infringement of any patents or other rights of third parties, which would result from its use. No other circuits, patents, or licenses are implied. This product is intended for use in normal commercial applications. Any other applications such as those requiring extended temperature range, high reliability, or other extraordinary environmental requirements are not recommended without additional processing by IDT. IDT reserves the right to change any circuitry or specifications without notice. IDT does not authorize or warrant any IDT product for use in life support devices or critical medical instruments.

Revision History

Rev.	Originator	Issue Date	Description	Page #
A	RDW	1/7/2011	Initial Release	
B	RDW	1/25/2011	1. Corrected Pin 14 is corrected to be DIF_2 true, not complement 2. Added PD# latency (tSTAB) to electrical tables. 3. Input slew rate changed FROM 0.4V/ns MIN to 1.0V/ns MIN. Max value stays unchanged. 4. Output slew rate changed FROM 0.5V/ns – 2.0V/ns TO 1 V/ns – 4V/ns. 5. Output Disabled Current changed to Power Down Current. 6. Reference to Bypass mode removed, this part has no PLL and always operates in bypass mode. 7. Added footnote 5 to PCIE Phase Jitter Parameter Tables.	Various
C	RDW	5/9/2011	1. Updated electrical characterisitcs and ordering information 2. Updated ordering information to indicate Rev A.	Various
D	RDW	6/2/2011	1. Tightened additve phase jitter specifications 2. Added part marking information	1, 9, 10
E	RDW	10/6/2011	Release to final.	
F	RDW	11/22/2011	1. Changed title to "2:1 PCIE GEN1/2/3 Clock Multiplexer" 2. Updated PCIE Phase Jitter table	Various
F	RDW	6/7/2013	Corrected typo in DS title. Was "2:1 PCIE."; now "2:4 PCIE."	Various

IDT5V41067A

2:4 PCIE GEN1/2/3 CLOCK MULTIPLEXER

Innovate with IDT and accelerate your future networks. Contact:

www.IDT.com

For Sales

800-345-7015
408-284-8200
Fax: 408-284-2775

For Tech Support

www.idt.com/go/clockhelp

Corporate Headquarters

Integrated Device Technology, Inc.
www.idt.com



Looking for pricing, stock, or lifecycle information?

Click below to explore more details on WIN SOURCE:

-  [View 5V41067APGG8 on WIN SOURCE](#)
-  [IDT, Integrated Device Technology Inc Information](#)

Optimize Your Supply Chain with WIN SOURCE Solutions

-  Global Sourcing Solution
-  Obsolete Management
-  Cost Control Management
-  Shortage Management
-  Alternative Solution
-  Excess Inventory Management