

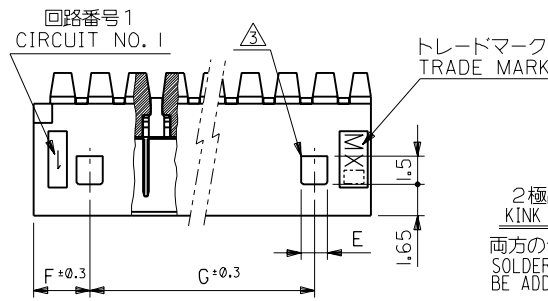

**THE DATASHEET OF**  
**530151010**





2極品のキンク形態図  
KINK FORM FOR 2 CKTS.  
両方のテールにキンクを施す。  
SOLDER TAIL KINK SHOULD  
BE ADDED ON BOTH TAILS.

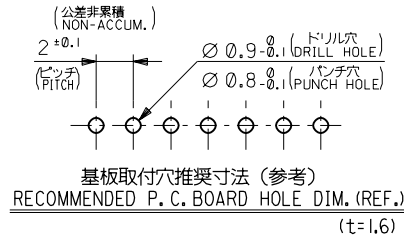
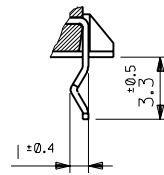

注記 NOTES

1. 嵌合相手 : 510Q4 シリーズ  
MATES WITH : 510Q4 SERIES
2. 3極以上のキンクは、1極おきに2カ所以上に施すこと。  
KINK TO BE ADDED ON THE ODD NUMBER  
SOLDER TAILS.(FROM THE TRADE MARK SIDE)
3. ロック穴は、2極と3極は1カ所、4極以上は2カ所とする。  
LOCKING HOLE : ONE PLACE FOR 2 AND 3 CKTS.  
TWO PLACES FOR 4 AND MORE THAN 4 CKTS.

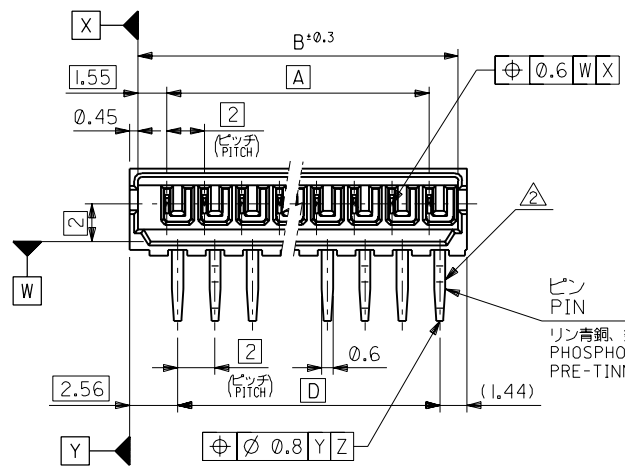

ピン  
PIN  
リン青銅、錫メッキ (0.9 μm MIN.)  
PHOSPHOR BRONZE  
PRE-TINNED(0.9 μm MIN.)

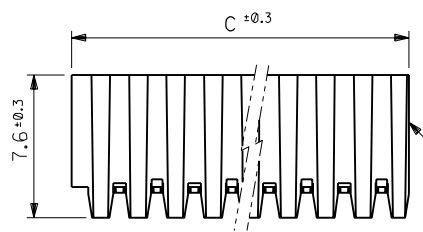
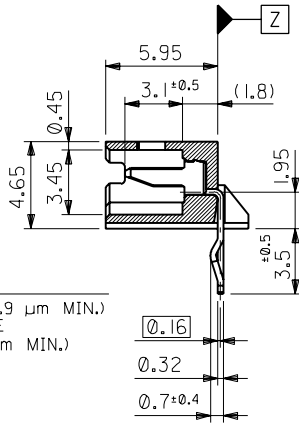

ガラス繊維入りナイロン66 (カラー: オフホワイト)  
GLASS FILLED NYLON66 (COLOR: OFF-WHITE)  
UL 94V-0

26	3	1.4	28	32	31.1	28	53015-1510	15
24	↑	↑	26	30	29.1	26	↑ -1410	14
22			24	28	27.1	24	↑ -1310	13
20			22	26	25.1	22	↑ -1210	12
18			20	24	23.1	20	↑ -1110	11
16			18	22	21.1	18	↑ -1010	10
14			16	20	19.1	16	↑ -0910	9
12			14	18	17.1	14	↑ -0810	8
10			12	16	15.1	12	↑ -0710	7
8			10	14	13.1	10	↑ -0610	6
6	↓	↓	8	12	11.1	8	↑ -0510	5
4	3	1.4	6	10	9.1	6	↑ -0410	4
—	4	3.4	4	8	7.1	4	↑ -0310	3
—	3	1.4	2	6	5.1	2	↑ 53015-0210	2
G	F	E	D	C	B	A	ENG. NO.	極数 NO. OF CKTS.

材料 MATERIAL		図中参照 SEE DWG.		MOLLEX MOLEX-JAPAN CO.,LTD. 日本モレックス株式会社	
仕上げ FINISH		—H—		REVISE ONLY ON CAD SYSTEM	
適用電線範囲 WIRE RANGE		—H—		TITLE 名称 2.0 LOW PROFILE WAFER ASS'Y R/A	
被覆外径 INS. RANGE		—H—		DWG. NO. SD-53015-***10	
DRAWN BY '93/3/31 H.HIRAMOTO		CHK'D BY '93/3/31 H.HIRAMOTO		REV E	
APP'D BY '93/3/31 M.FUKUSHIMA		DR. DATE M.F. '93/3/31		SCALE 4 - 1	
角度 ANGLE ±3°		再作図及び変更 REDRAWN & REVISED (LS0279)		DR. DATE	
30以上 OVER ±0.3		変更内容 REVISION RECORD		LTR	
10以上 30未満 OVER ±0.25		一般公差 GENERAL TOLERANCES		記号 REVISION RECORD	
10未満 UNDER ±0.2					

## Looking for pricing, stock, or lifecycle information?

Click below to explore more details on WIN SOURCE:

 [View 530151010 on WIN SOURCE](#)

 [Molex, LLC Information](#)

## Optimize Your Supply Chain with WIN SOURCE Solutions

-  Global Sourcing Solution
-  Obsolete Management
-  Cost Control Management
-  Shortage Management
-  Alternative Solution
-  Excess Inventory Management