



AK4420

192kHz 24-Bit Stereo $\Delta\Sigma$ DAC with 2Vrms Output

GENERAL DESCRIPTION

The AK4420 is a 5V 24-bit stereo DAC with an integrated 2Vrms output buffer. A charge pump in the buffer develops an internal negative power supply rail that enables a ground-referenced 2Vrms output. Using AKM's multi bit modulator architecture, the AK4420 delivers a wide dynamic range while preserving linearity for improved THD+N performance. The AK4420 integrates a combination of switched-capacitor and continuous-time filters, increasing performance for systems with excessive clock jitter. The 24-bit word length and 192kHz sampling rate make this part ideal for a wide range of consumer audio applications, such as DVD, AV receiver system and set-top boxes. The AK4420 is offered in a space saving 16pin TSSOP package.

FEATURES

- Sampling Rate Ranging from 8kHz to 192kHz
- 128 times Oversampling (Normal Speed Mode)
- 64 times Oversampling (Double Speed Mode)
- 32 times Oversampling (Quad Speed Mode)
- 24-Bit 8 times FIR Digital Filter
- Switched-Capacitor Filter with High Tolerance to Clock Jitter
- Single Ended 2Vrms Output Buffer
- Soft mute
- I/F format: 24-Bit MSB justified or I²S
- Master clock: 512fs, 768fs or 1152fs (Normal Speed Mode)
256fs or 384fs (Double Speed Mode)
128fs, 192fs (Quad Speed Mode)
- THD+N: -92dB
- Dynamic Range: 105dB
- Automatic Power-on Reset Circuit
- Power supply: +4.5 ~ +5.5V
- Ta = -20 to 85°C (ET), -40 to 85°C (VT)
- Small Package: 16pin TSSOP (6.4mm x 5.0mm)

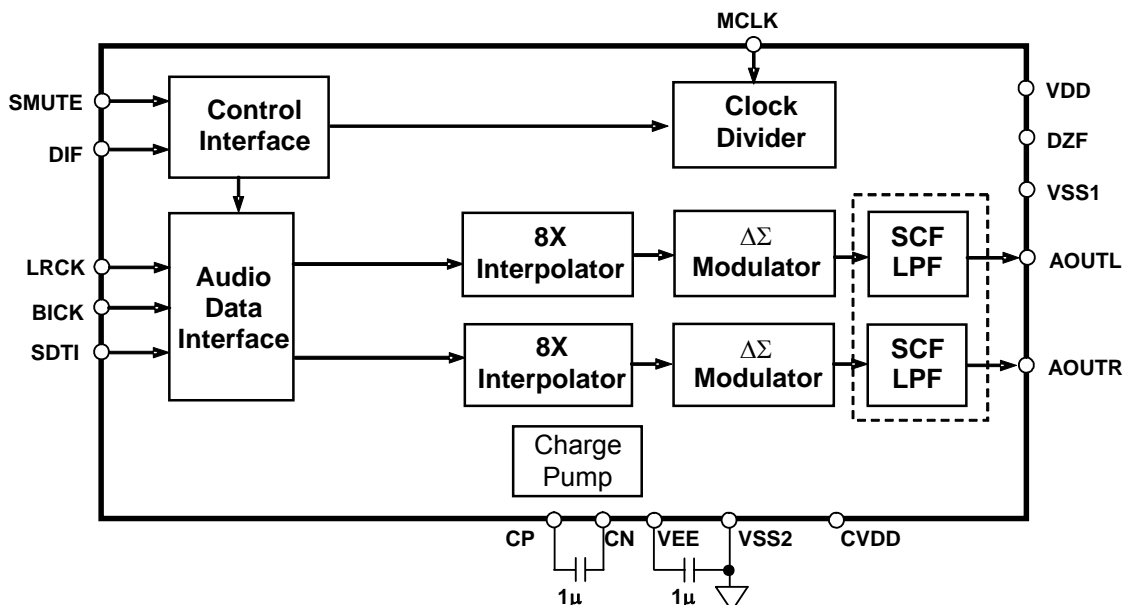

PIN/FUNCTION

No.	Pin Name	I/O	Function
1	CN	I	Negative Charge Pump Capacitor Terminal Pin Connect to CP with a 1.0 μ F capacitor that should have the low ESR (Equivalent Series Resistance) over all temperature range. When this capacitor has the polarity, the positive polarity pin should be connected to the CP pin. Non polarity capacitors can also be used.
2	CP	I	Positive Charge Pump Capacitor Terminal Pin Connect to CN with a 1.0 μ F capacitor that should have the low ESR (Equivalent Series Resistance) over all temperature range. When this capacitor has the polarity, the positive polarity pin should be connected to the CP pin. Non polarity capacitors can also be used.
3	SMUTE	I	Soft Mute Enable Pin (Internal pull down: 100k Ω) “H”: Enable, “L”: Disable
4	MCLK	I	Master Clock Input Pin An external TTL clock should be input on this pin.
5	BICK	I	Audio Serial Data Clock Pin
6	SDTI	I	Audio Serial Data Input Pin
7	LRCK	I	L/R Clock Pin
8	DIF	I	Audio Data Interface Format Pin “L”: Left Justified, “H”: I2S
9	AOUTR	O	Rch Analog Output Pin When power down, outputs VSS(0V, typ).
10	AOUTL	O	Lch Analog Output Pin When power down, outputs VSS(0V, typ).
11	VDD	-	DAC Power Supply Pin: 4.5V~5.5V
12	VSS1	-	Ground Pin1
13	DZF	O	Zero Input Detect Pin
14	CVDD	-	Charge Pump Power Supply Pin: 4.5V~5.5V
15	VSS2	-	Ground Pin2
16	VEE	O	Negative Voltage Output Pin Connect to VSS2 with a 1.0 μ F capacitor that should have the low ESR (Equivalent Series Resistance) over all temperature range. When this capacitor has the polarity, the positive polarity pin should be connected to the VSS2 pin. Non polarity capacitors can also be used.

Note: All input pins except for the CN pin should not be left floating.

ABSOLUTE MAXIMUM RATINGS

(VSS1=VSS2=0V; [Note 1](#))

Parameter	Symbol	min	max	Units
Power Supply	VDD	-0.3	+6.0	V
	CVDD	-0.3	+6.0	V
Input Current (any pins except for supplies)	IIN	-	±10	mA
Input Voltage	VIND	-0.3	VDD+0.3	V
Ambient Operating Temperature	AK4420ET	Ta	85	°C
	AK4420VT	Ta	85	°C
Storage Temperature	Tstg	-65	150	°C

Note 1. All voltages with respect to ground.

Note 2. VSS1, VSS2 connect to the same analog ground.

WARNING: Operation at or beyond these limits may result in permanent damage to the device.
Normal operation is not guaranteed at these extremes.

RECOMMENDED OPERATING CONDITIONS

(VSS1=VSS2=0V; [Note 1](#))

Parameter	Symbol	min	typ	max	Units
Power Supply	VDD	+4.5	+5.0	+5.5	V
	CVDD		VDD		

Note 3. CVDD should be equal to VDD

*AKM assumes no responsibility for the usage beyond the conditions in this datasheet.

ANALOG CHARACTERISTICS

(Ta = 25°C; VDD=CVDD = +5.0V; fs = 44.1 kHz; BICK = 64fs; Signal Frequency = 1 kHz;
24bit Input Data; Measurement frequency = 20Hz ~ 20kHz; Ri ≥5kΩ)

Parameter	min	typ	max	Units	
Resolution			24	Bits	
Dynamic Characteristics (Note 4)					
THD+N (0dBFS)	fs=44.1kHz, BW=20kHz		-92	-84	dB
	fs=96kHz, BW=40kHz		-92	-	dB
	fs=192kHz, BW=40kHz		-92	-	dB
Dynamic Range (-60dBFS with A-weighted. (Note 5))	98	105		dB	
S/N (A-weighted. (Note 6))	98	105		dB	
Interchannel Isolation (1kHz)	90	100		dB	
Interchannel Gain Mismatch		0.2	0.5	dB	
DC Accuracy					
DC Offset (at output pin)	-60	0	+60	mV	
Gain Drift		100	-	ppm/°C	
Output Voltage (Note 7)	1.97	2.12	2.27	Vrms	
Load Capacitance (Note 8)			25	pF	
Load Resistance	5			kΩ	
Power Supplies					
Power Supply Current: (Note 9)					
Normal Operation (fs≤96kHz)		24	36	mA	
Normal Operation (fs=192kHz)		27	40	mA	
Power-Down Mode (Note 10)		10	100	μA	

Note 4. Measured by Audio Precision (System Two). Refer to the evaluation board manual.

Note 5. 98dB for 16bit input data

Note 6. S/N does not depend on input data size.

Note 7. Full-scale voltage (0dB). Output voltage is proportional to the voltage of VDD,

$$AOUT (typ.@0dB) = 2.12V_{rms} \times VDD/5.$$

Note 8. In case of driving capacitive load, inset a resistor between the output pin and the capacitive load.

Note 9. The current into VDD and CVDD.

Note 10. All digital inputs including clock pins (MCLK, BICK and LRCK) are fixed to VSS or VDD

FILTER CHARACTERISTICS

(Ta = 25°C; VDD=CVDD = +4.5 ~ +5.5V; fs = 44.1 kHz)

Parameter	Symbol	min	Typ	max	Units	
Digital filter						
Passband	±0.05dB (Note 11) -6.0dB	0	22.05	20.0	kHz	
		-		-	kHz	
Stopband (Note 11)		24.1			kHz	
Passband Ripple				± 0.02	dB	
Stopband Attenuation		54			dB	
Group Delay (Note 12)		-	19.3	-	1/fs	
Digital Filter + LPF						
Frequency Response	20.0kHz	fs=44.1kHz	FR	-	± 0.05	dB
	40.0kHz	fs=96kHz	FR	-	± 0.05	dB
	80.0kHz	fs=192kHz	FR	-	± 0.05	dB

Note 11. The passband and stopband frequencies scale with fs(system sampling rate).

For example, PB=0.4535×fs (@±0.05dB), SB=0.546×fs.

Note 12. Calculated delay time caused by digital filter. This time is measured from setting the 16/24bit data of both channels to input register to the output of the analog signal.

DC CHARACTERISTICS

(Ta = 25°C; VDD=CVDD = +4.5 ~ +5.5V)

Parameter	Symbol	min	typ	max	Units
High-Level Input Voltage	VIH	2.2	-	-	V
Low-Level Input Voltage	VIL	-	-	0.8	V
High-Level Output Voltage (Iout = -80uA)	VOH	VDD-0.4	-	-	V
Low-Level Output Voltage (Iout = 80uA)	VOL	-	-	0.4	V
Input Leakage Current (Note 13)	Iin	-	-	± 10	μA

Note 13. The SMUTE pin is not included. The SMUTE pin has internal pull-down resistor (typ.100kΩ).

SWITCHING CHARACTERISTICS

(Ta = 25°C; VDD=CVDD = +4.5 ~ +5.5V)

Parameter	Symbol	min	Typ	max	Units
Master Clock Frequency	fCLK	4.096	11.2896	36.864	MHz
Duty Cycle	dCLK	30		70	%
LRCK Frequency					
Normal Speed Mode	fsn	8		48	kHz
Double Speed Mode	fsd	32		96	kHz
Quad Speed Mode	fsq	120		192	kHz
Duty Cycle	Duty	45		55	%
Audio Interface Timing					
BICK Period					
Normal Speed Mode	tBCK	1/128fsn			ns
Double Speed Mode	tBCK	1/64fsd			ns
Quad Speed Mode	tBCK	1/64fsq			ns
BICK Pulse Width Low	tBCKL	30			ns
Pulse Width High	tBCKH	30			ns
BICK “↑” to LRCK Edge (Note 14)	tBLR	20			ns
LRCK Edge to BICK “↑” (Note 14)	tLRB	20			ns
SDTI Hold Time	tSDH	20			ns
SDTI Setup Time	tSDS	20			ns

Note 14. BICK rising edge must not occur at the same time as LRCK edge.

■ Timing Diagram

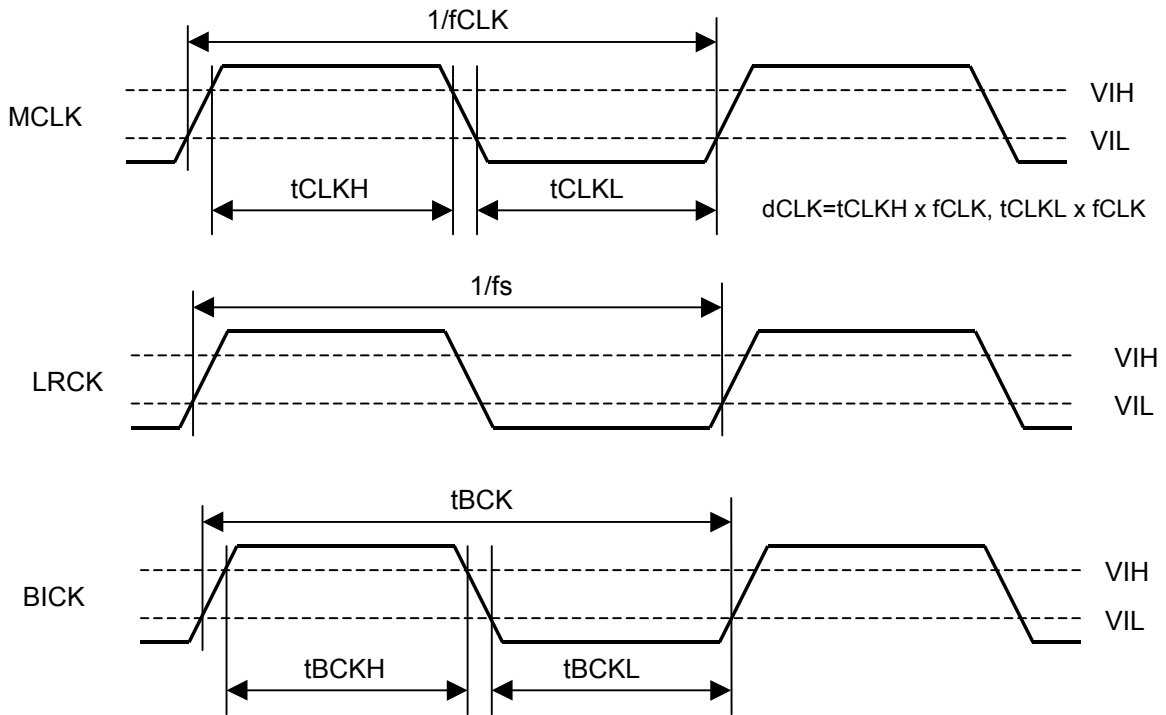

Figure 1. Clock Timing

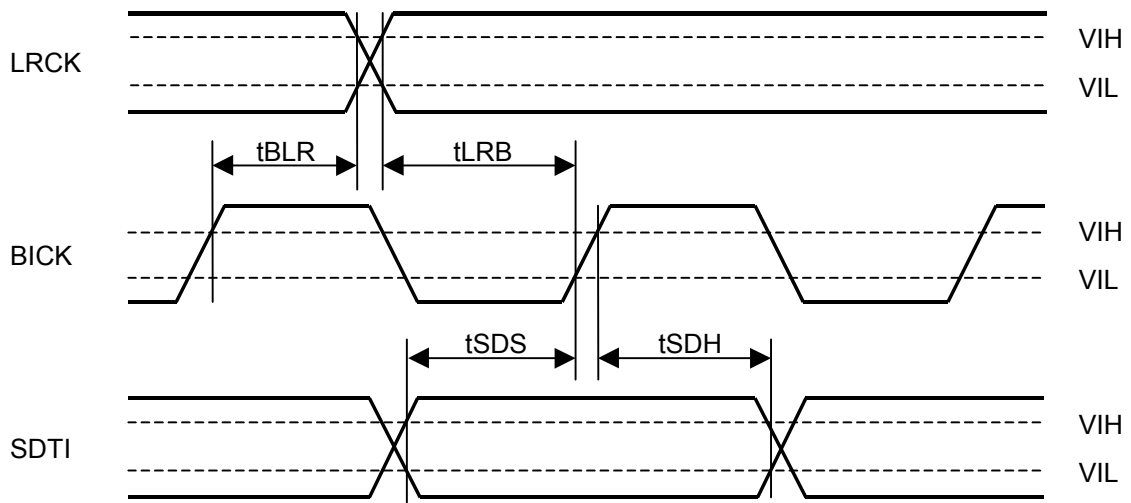

Figure 2. Serial Interface Timing

OPERATION OVERVIEW

■ System Clock

The external clocks required to operate the AK4420 are MCLK, LRCK and BICK. The master clock (MCLK) should be synchronized with LRCK but the phase is not critical. The MCLK is used to operate the digital interpolation filter and the delta-sigma modulator. Sampling speed and MCLK frequency are detected automatically and then the internal master clock is set to the appropriate frequency (Table 1).

The AK4420 is automatically placed in power saving mode when MCLK and LRCK stop during normal operation mode, and the analog output is forced to 0V(typ). When MCLK and LRCK are input again, the AK4420 is powered up. After power-up, the AK4420 is in the power-down mode until MCLK and LRCK are input.

LRCK fs	MCLK (MHz)							Sampling Speed
	128fs	192fs	256fs	384fs	512fs	768fs	1152fs	
32.0kHz	-	-	-	-	16.3840	24.5760	36.8640	Normal
44.1kHz	-	-	-	-	22.5792	33.8688	-	
48.0kHz	-	-	-	-	24.5760	36.8640	-	
32.0kHz			8.192	12.288				Double
44.1kHz			11.2896	16.9344				
48.0kHz			12.288	18.432				
88.2kHz	-	-	22.5792	33.8688	-	-	-	
96.0kHz	-	-	24.5760	36.8640	-	-	-	Quad
176.4kHz	22.5792	33.8688	-	-	-	-	-	
192.0kHz	24.5760	36.8640	-	-	-	-	-	

Table 1. System Clock Example

When MCLK= 256fs/384fs, the AK4420 supports sampling rate of 32kHz~96kHz (Table 1). However, when the sampling rate is 32kHz~48kHz, DR and S/N will degrade as compared to when MCLK= 512fs/768fs. (Table 2)

MCLK	DR,S/N
256fs/384fs	102dB
512fs/768fs	105dB

Table 2. Relationship between MCLK frequency and DR, S/N (fs= 44.1kHz)

■ Audio Serial Interface Format

The audio data is shifted in via the SDTI pin using the BICK and LRCK inputs. The DIF pin can select between two serial data modes as shown in Table 3. In all modes the serial data is MSB-first, two's complement format and it is latched on the rising edge of BICK. In one cycle of LRCK, eight "H" pulses or more must not be input to the DIF pin.

Mode	DIF	SDTI Format	BICK	Figure
0	L	24bit MSB justified	≥48fs	Figure 3
1	H	24bit I ² S	≥48fs	Figure 4

Table 3. Audio Data Formats

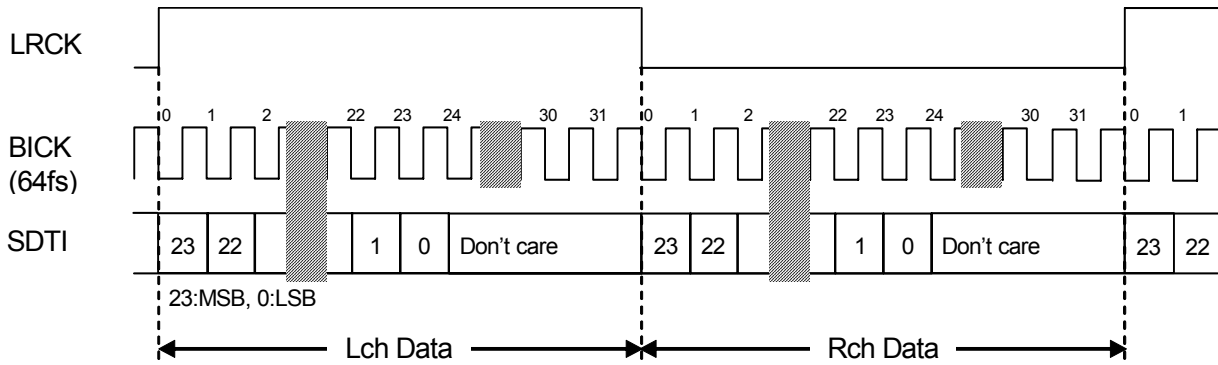

Figure 3. Mode 0 Timing

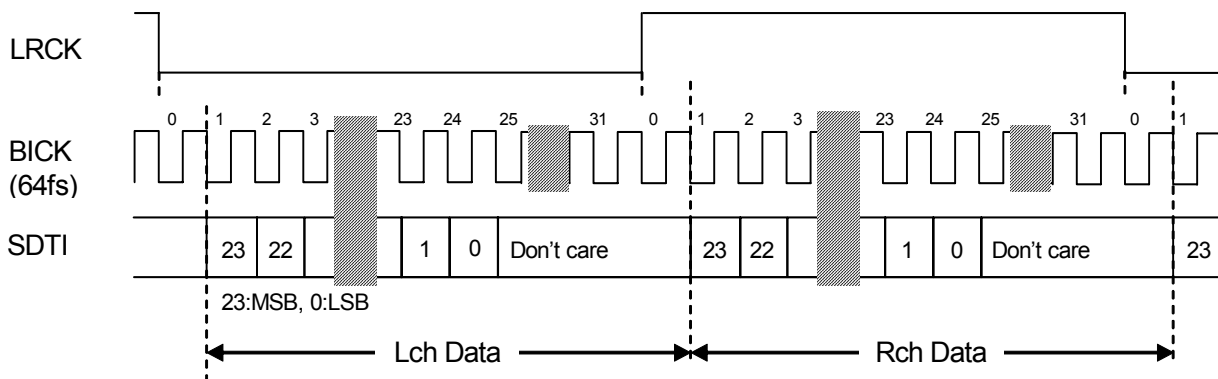

Figure 4. Mode 1 Timing

■ Zero Detect Function

When the input data for both channels are continuously zeros for 8192 LRCK cycles, the DZF pin is set to “H”. The DZF pin immediately returns to “L” if the input data for both channels are not zero.

■ Analog Output Block

The internal negative power supply generation circuit (Figure 5) provides a negative power supply for the internal 2Vrms amplifier. It allows the AK4420 to output an audio signal centered at VSS (0V, typ) as shown in Figure 6. The negative power generation circuit (Figure 5) needs 1.0uF capacitors (Ca, Cb) with low ESR (Equivalent Series Resistance). If this capacitor is polarized, the positive polarity pin should be connected to the CP and VSS2 pins. This circuit operates by clocks generated from MCLK. When MCLK stops, the AK4420 is placed in the reset mode automatically and the analog outputs settle to VSS (0V, typ).

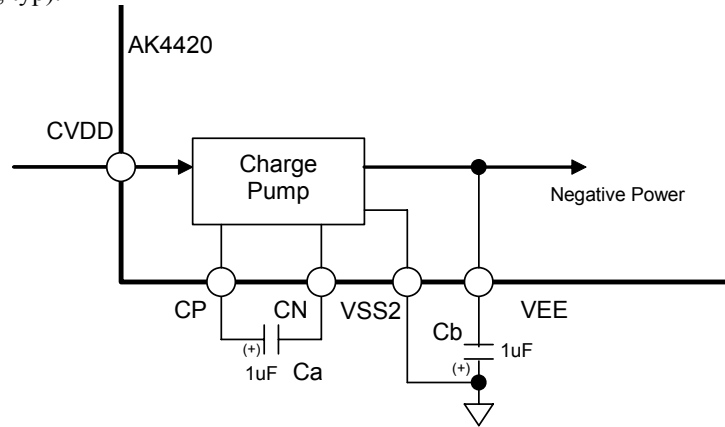

Figure 5. Negative Power Generation Circuit

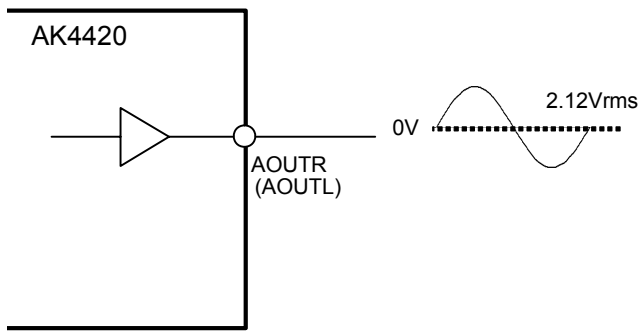
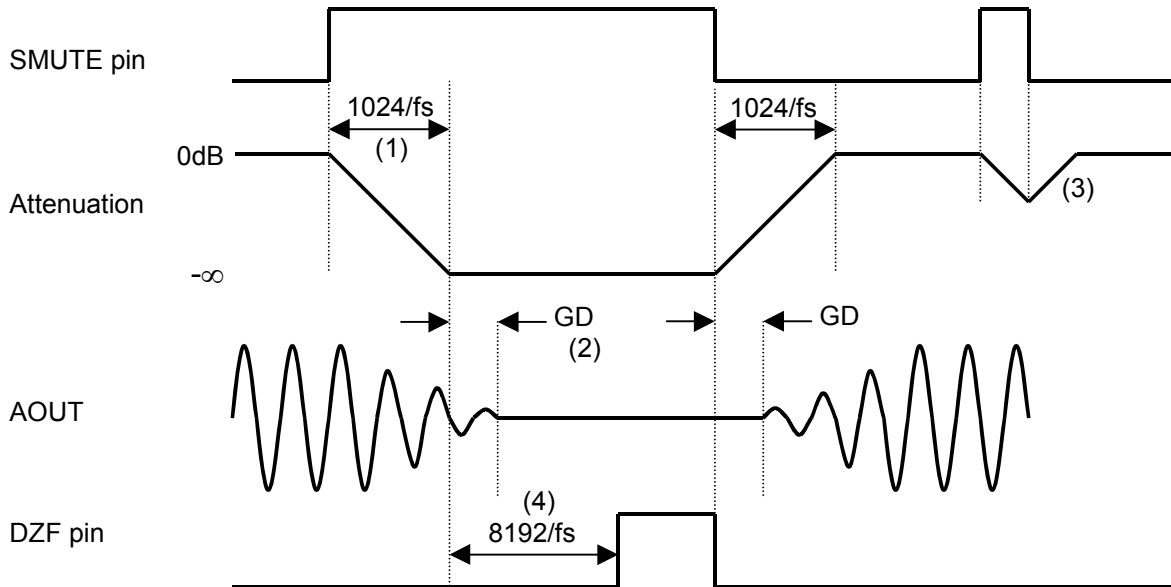

Figure 6. Audio Signal Output

■ Soft Mute Operation

Soft mute operation is performed in the digital domain. When the SMUTE pin is set “H”, the output signal is attenuated to $-\infty$ in 1024 LRCK cycles. When the SMUTE pin is returned to “L”, the mute is cancelled and the output attenuation gradually changes to 0dB in 1024 LRCK cycles. If the soft mute is cancelled within the 1024 LRCK cycles after starting this operation, the attenuation is discontinued and it is returned to 0dB by the same cycle. Soft mute is effective for changing the signal source without stopping the signal transmission.



Notes:

- (1) The time for input data be attenuation to $-\infty$, is
 Normal Speed Mode: 1024 LRCK cycles (1024/fs).
 Double Speed Mode: 2048 LRCK cycles (2048/fs).
 Quad Speed Mode : 4096 LRCK cycles (4096/fs).
- (2) The analog output corresponding to a specific digital input has a group delay, GD.
- (3) If soft mute is cancelled before attenuating to $-\infty$ after starting the operation, the attenuation is discontinued and returned to ATT level in the same cycle.
- (4) When the input data for both channels are continuously zeros for 8192 LRCK cycles, the DZF pin is set to “H”. The DZF pin immediately is set to “L” if the input data are not zero after going to DZF “H”.

Figure 7. Soft Mute and Zero Detect Function

■ System Reset

The AK4420 is in power down mode upon power-up. The MCLK should be input after the power supplies are ramped up. The AK4420 is in power-down mode until LRCK are input.

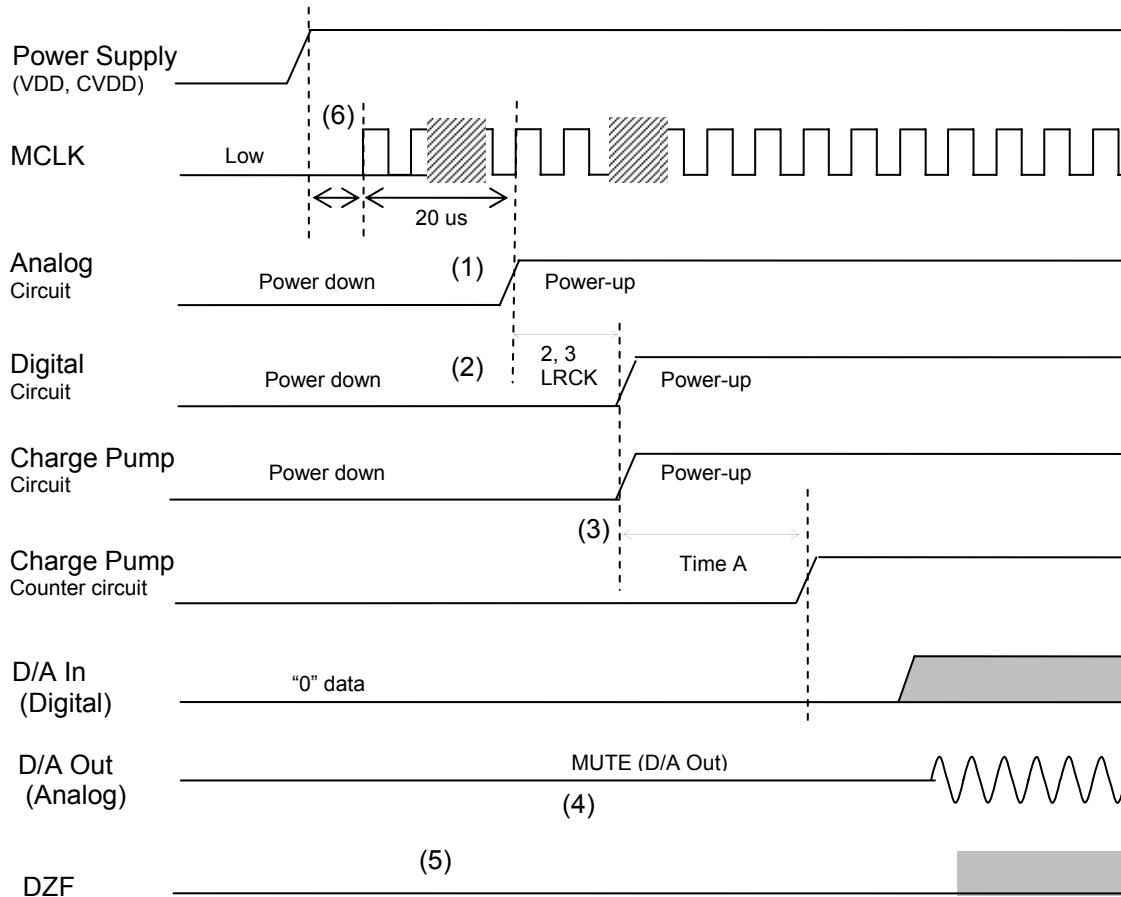

Notes:

- (1) Approximately 20us after a MCLK input is detected, the internal analog circuit is powered-up.
- (2) The digital circuit is powered-up after 2 or 3 LRCK cycles following the detection of MCLK.
- (3) The charge pump counter starts after the charge pump circuit is powered-up. The DAC outputs a valid analog signal after Time A.
 $\text{Time A} = 1024 / (f_s \times 16)$: Normal speed mode
 $\text{Time A} = 1024 / (f_s \times 8)$: Double speed mode
 $\text{Time A} = 1024 / (f_s \times 4)$: Quadruple speed mode
- (4) No audible click noise occurs under normal conditions.
- (5) The DZF pin is "L" in the power-down mode.
- (6) The power supply must be powered-up when the MCLK pin is "L". MCLK must be input after 20us when the power supply voltage achieves 80% of VDD. If not, click noise may occur at a different time from this figure.

Figure 8. System Reset Diagram

■ Reset Function

When the MCLK or LRCK stops, the AK4420 is placed in reset mode and its analog outputs are set to VSS (0V, typ). When the MCLK and LRCK are restarted, the AK4420 returns to normal operation mode. The BICK can be stopped when MCLK or LRCK is stopped, but it must not be stopped when MCLK and LRCK are supplied.

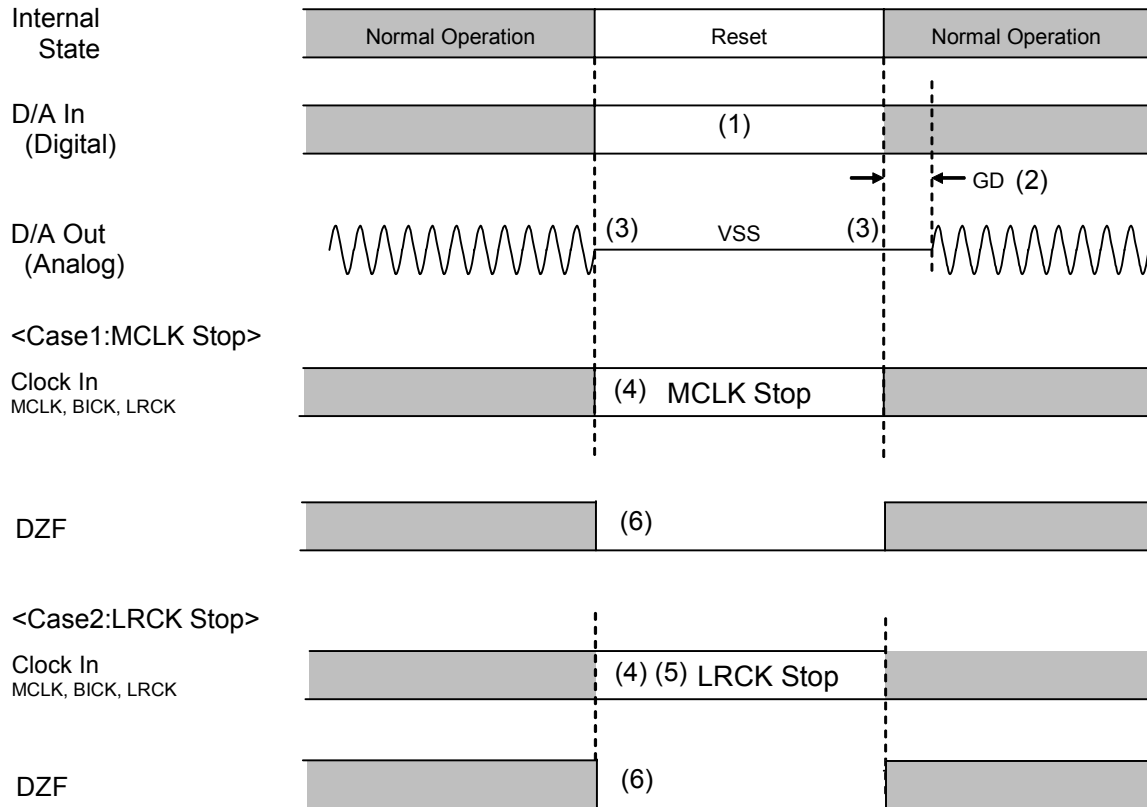

Notes:

- (1) Digital data can be stopped. The click noise after MCLK and LRCK are input again can be reduced by inputting the "0" data during this period.
- (2) The analog output corresponding to a specific digital input has group delay (GD).
- (3) No audible click noise occurs under normal conditions.
- (4) Clocks (MCLK, BICK, LRCK) can be stopped in the reset mode (MCLK or LRCK is stopped).
- (5) The AK4420 detects the stop of LRCK if LRCK stops for more than 2048/fs. When LRCK is stopped, the AK4420 exits reset mode after LRCK is inputted..
- (6) The DZF pin is set to "L" in the reset mode.

Figure 9. Reset Timing Example

SYSTEM DESIGN

Figure 10 shows the system connection diagram. An evaluation board (AKD4420) is available for fast evaluation as well as suggestions for peripheral circuitry.

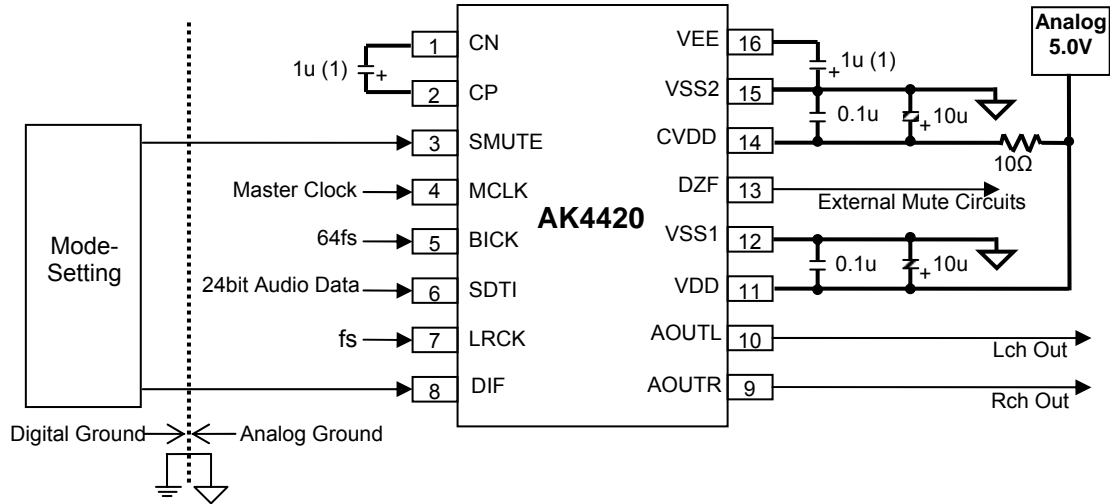

Note:

- Use low ESR (Equivalent Series Resistance) capacitors. When using polarized capacitors, the positive polarity pin should be connected to the CP and VSS2 pin.
- VSS1 and VSS2 should be separated from digital system ground.
- Digital input pins should not be allowed to float.

Figure 10. Typical Connection Diagram

1. Grounding and Power Supply Decoupling

VDD, CVDD and VSS are supplied from the analog supply and should be separated from the system digital supply. Decoupling capacitors, especially 0.1μF ceramic capacitors for high frequency bypass, should be placed as near to VDD and CVDD as possible. The differential voltage between VDD and VSS pins set the analog output range. **The power-up sequence between VDD and CVDD is not critical.**

2. Analog Outputs

The analog outputs are single-ended and centered around the VSS (ground) voltage. The output signal range is typically 2.12Vrms (typ @VDD=5V). The internal switched-capacitor filter (SCF) and continuous-time filter (CTF) attenuate the noise generated by the delta-sigma modulator beyond the audio passband. Using single a 1st-order LPF (Figure 11) can reduce noise beyond the audio passband. Figure 12 shows example in the case of 10kΩ, 100kΩ terminus.

The output voltage is a positive full scale for 7FFFFFFH (@24bit data) and a negative full scale for 800000H (@24bit data). The ideal output is 0V (VSS) voltage for 000000H (@24bit data). The DC offset is ±60mV or less.

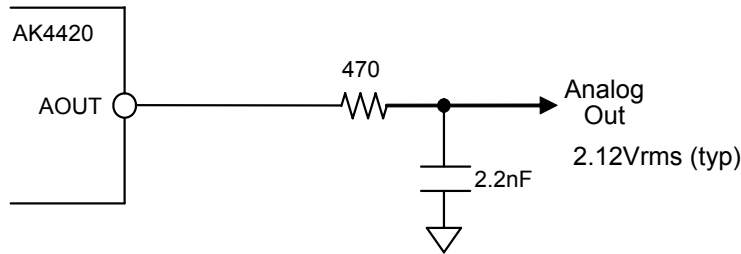

(fc = 154kHz, gain = -0.28dB @ 40kHz, gain = -1.04dB @ 80kHz)

Figure 11. External 1st order LPF Circuit Example1

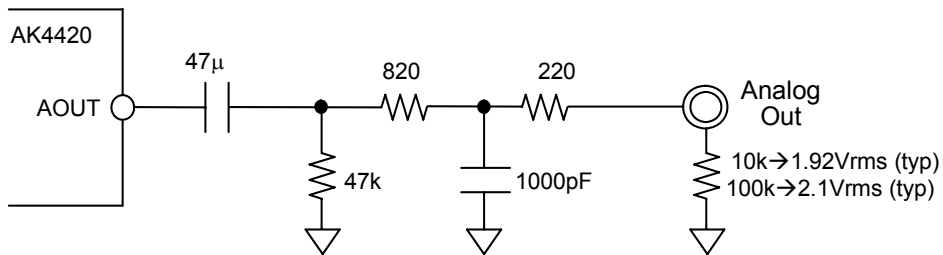
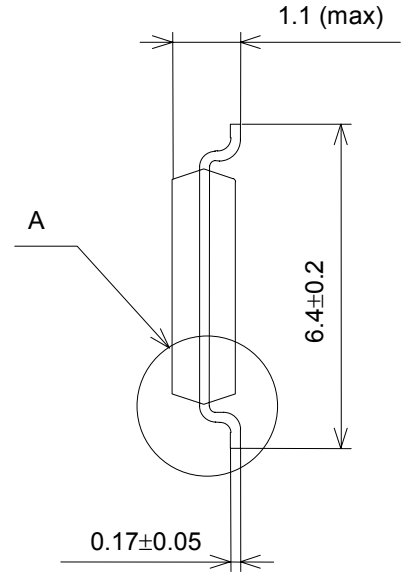
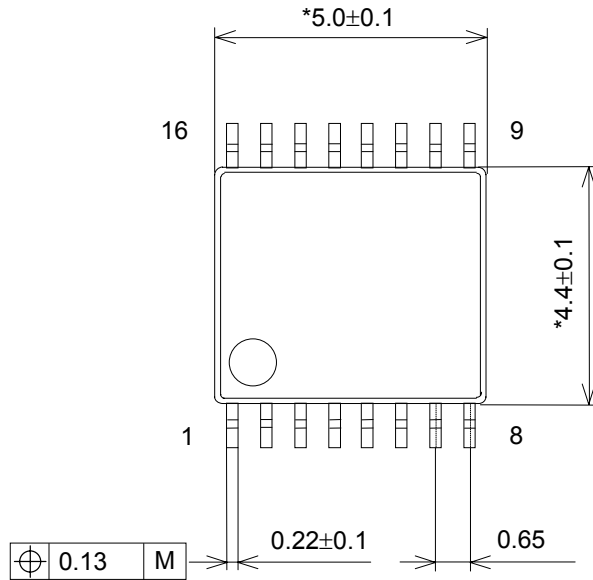

Figure 12. External 1st order LPF Circuit Example2

PACKAGE

16pin TSSOP (Unit: mm)



Detail A

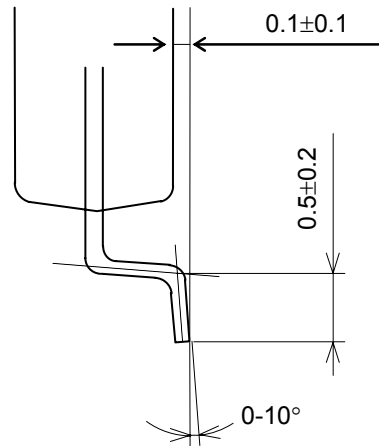
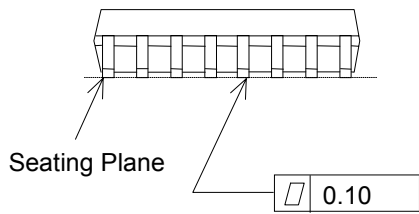

NOTE: Dimension "*" does not include mold flash.

■ Package & Lead frame material

Package molding compound:	Epoxy
Lead frame material:	Cu
Lead frame surface treatment:	Solder (Pb free) plate

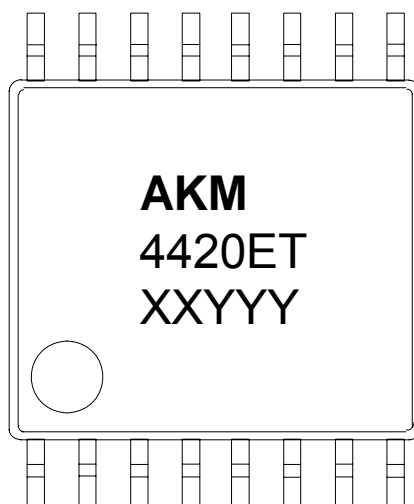
MARKING

- 1) Pin #1 indication
- 2) Date Code : XYYYY (5 digits)
XX: Lot#
YYY: Date Code
- 3) Marketing Code : 4420ET
- 4) Asahi Kasei Logo

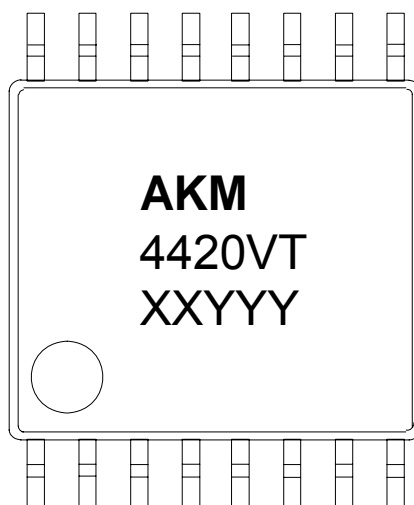

- 5) Pin #1 indication
- 6) Date Code : XYYYY (5 digits)
XX: Lot#
YYY: Date Code
- 7) Marketing Code : 4420VT
- 8) Asahi Kasei Logo

REVISION HISTORY



Date (YY/MM/DD)	Revision	Reason	Page	Contents
07/11/05	00	First Edition		
07/12/04	01	Error Correction	13	Figure 8. The description of the click noise was corrected.
			14	Figure 9. The description of the click noise was corrected.
07/12/17	02	Error Correction	14	“The BICK can be stopped when MCLK or LRCK is stopped, but it must not be stopped when MCLK and LRCK are supplied.” was deleted.
08/04/01	03	Spec Addition	1	FEATURE(Ta) AK4420VT was added.
			2	Ordering Guide AK4420VT was added
			2	“Compatibility with AK4421 and AK4424” was added
			4	ABSOLUTE MAXIMUM RATINGS (Ambient Operating Temperature) AK4420VT was added.
			18	MARKING AK4420VT was added.
		Error Correction	6	Note13 pull-up -> pull down
			12	Normal Speed Mode: 1024 LRCK cycles (1020/fs) -> (1024/fs)
08/06/11	04	Error Correction	1	FEATURES “Digital de-emphasis” was deleted.
08/08/01	05	Error Correction	6	DC CHARACTERISTICS A row for the output voltage value was written as for input High-Level Input Voltage → High-Level Output Voltage Low-Level Input Voltage → Low-Level Output Voltage VIH → VOH VIL → VOL A cross-reference to Note 13 was added.
10/06/23	06	Error Correction	9	■ System Clock A description was changed.
		Specification Change	17	PACKAGE A package drawing dimension was changed.

IMPORTANT NOTICE

- These products and their specifications are subject to change without notice.
When you consider any use or application of these products, please make inquiries the sales office of Asahi Kasei Microdevices Corporation (AKM) or authorized distributors as to current status of the products.
- Descriptions of external circuits, application circuits, software and other related information contained in this document are provided only to illustrate the operation and application examples of the semiconductor products. You are fully responsible for the incorporation of these external circuits, application circuits, software and other related information in the design of your equipments. AKM assumes no responsibility for any losses incurred by you or third parties arising from the use of these information herein. AKM assumes no liability for infringement of any patent, intellectual property, or other rights in the application or use of such information contained herein.
- Any export of these products, or devices or systems containing them, may require an export license or other official approval under the law and regulations of the country of export pertaining to customs and tariffs, currency exchange, or strategic materials.
- AKM products are neither intended nor authorized for use as critical components^{Note1)} in any safety, life support, or other hazard related device or system^{Note2)}, and AKM assumes no responsibility for such use, except for the use approved with the express written consent by Representative Director of AKM. As used here:
 - Note1) A critical component is one whose failure to function or perform may reasonably be expected to result, whether directly or indirectly, in the loss of the safety or effectiveness of the device or system containing it, and which must therefore meet very high standards of performance and reliability.
 - Note2) A hazard related device or system is one designed or intended for life support or maintenance of safety or for applications in medicine, aerospace, nuclear energy, or other fields, in which its failure to function or perform may reasonably be expected to result in loss of life or in significant injury or damage to person or property.
- It is the responsibility of the buyer or distributor of AKM products, who distributes, disposes of, or otherwise places the product with a third party, to notify such third party in advance of the above content and conditions, and the buyer or distributor agrees to assume any and all responsibility and liability for and hold AKM harmless from any and all claims arising from the use of said product in the absence of such notification.

Looking for pricing, stock, or lifecycle information?

Click below to explore more details on WIN SOURCE:

-  [View AKD4420ET on WIN SOURCE](#)
-  [AKM Semiconductor Inc. Information](#)

Optimize Your Supply Chain with WIN SOURCE Solutions

-  Global Sourcing Solution
-  Obsolete Management
-  Cost Control Management
-  Shortage Management
-  Alternative Solution
-  Excess Inventory Management