



**THE DATASHEET OF  
J2CE4021-20**





**SUBJECT: Engineering Product Specification  
Generation 2, J1772™ Connector / Inlet Cable Assembly (UL File# 330790)**

**SPEC. # CCS-12003  
REV. LEVEL: B  
ORIGINAL DATE: 01/24/12  
REVISED DATE: 03/19/12**

**Prepared By: JG 01/24/12  
Approved By: LAW 02/21/12**



J2CE Connector

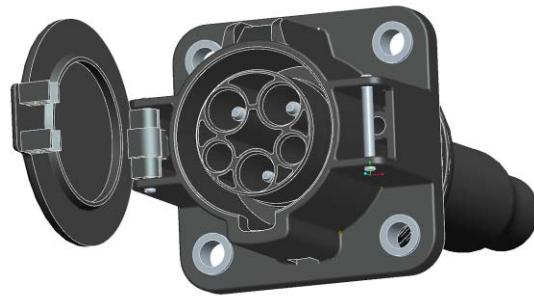

J2IV Inlet

**1. Purpose:**

To specify a connector / inlet assembly system using AC Level 1 and Level 2 charge levels for use with Electric Vehicle Service Equipment (EVSE) and Plug-in Hybrid Electric Vehicles. System built in accordance with SAE® standard # J1772\_201001 (current revision) and approved by regional worldwide test labs.

**2. Part Number Configuration**

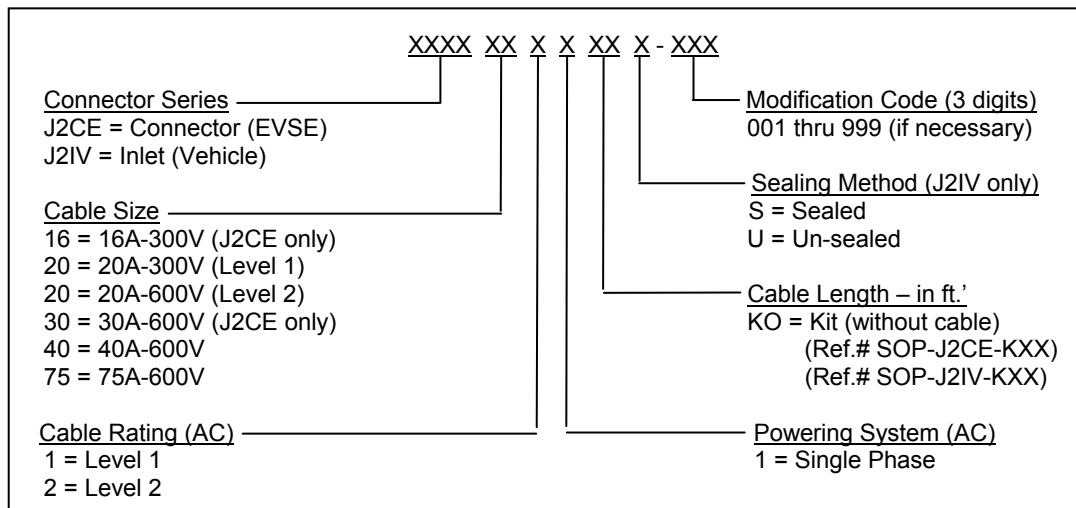

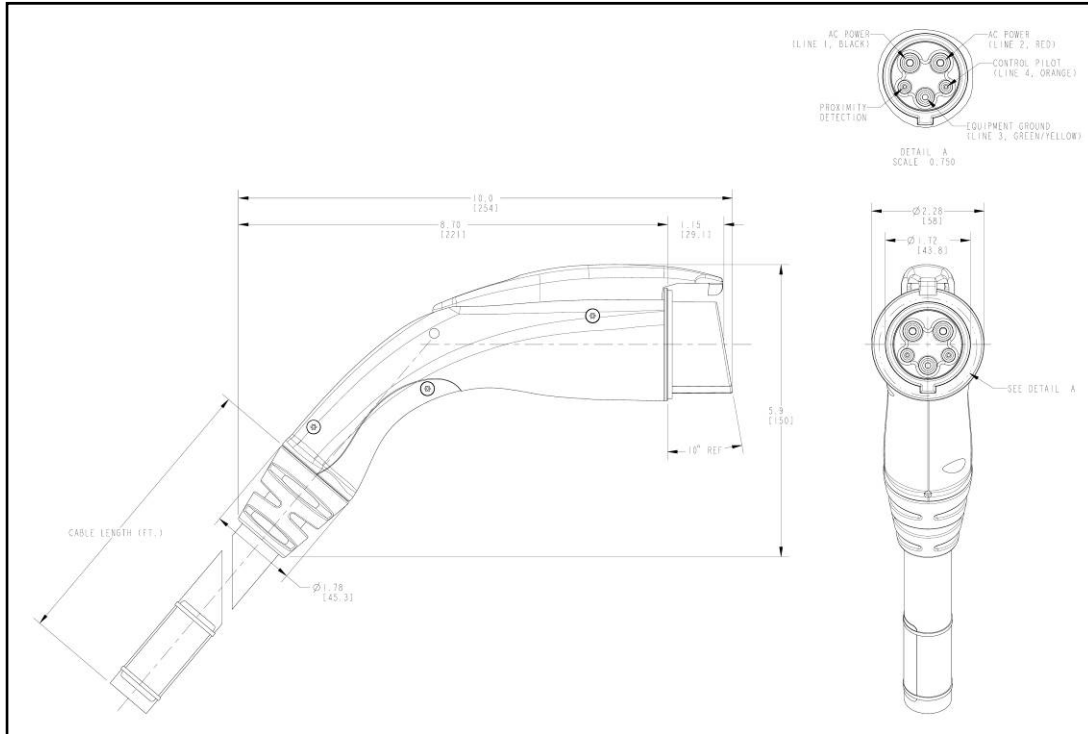
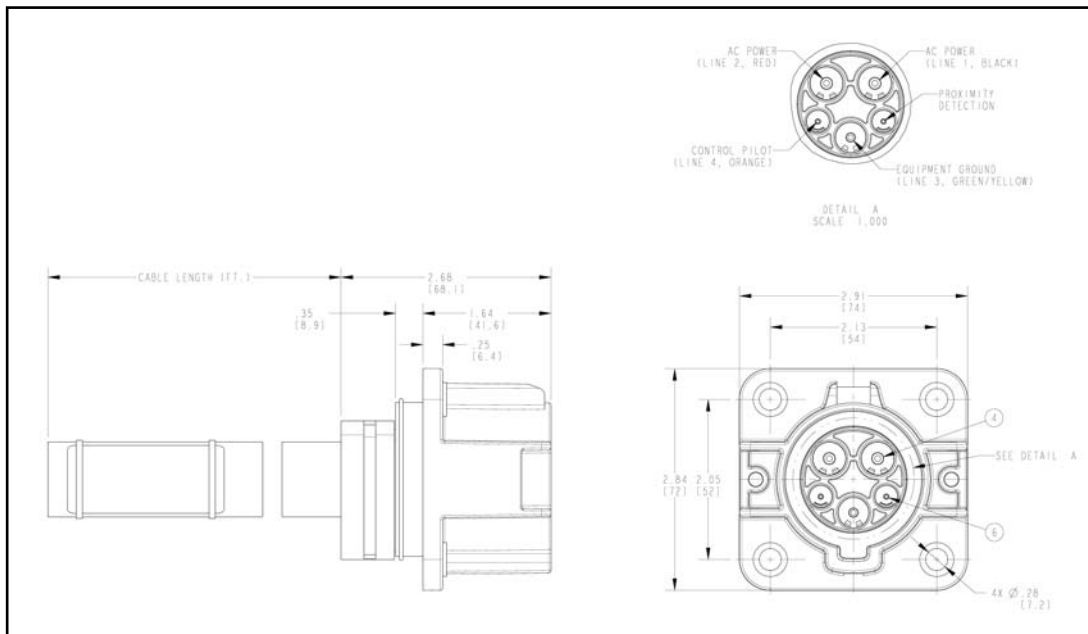
**SUBJECT: Engineering Product Specification  
Generation 2, J1772™ Connector / Inlet Cable Assembly**

J2CE Connector

J2IV Inlet

**SUBJECT: Engineering Product Specification  
Generation 2, J1772™ Connector / Inlet Cable Assembly**

### **3. Physical Characteristics**

#### **3.1. Materials**

Contact bodies – Copper Alloy

Latch – Zinc alloy

Contact spring members – Beryllium Copper

Inserts – Nylon, glass filled

Gasket – Silicone foam

Strain Relief – Thermoplastic Elastomer (TPE)

Handle – Polybutylene Terephthalate (PBT)

Cable – Type EVE rated, 5 or 4 conductor (UL62 compliant)

- 75A – #6 AWG (2), #8 AWG (1), Ø.92" [24mm] OD max.
- 40A – #8 AWG (2), #10 AWG (1), Ø.91" [23mm] OD max.
- 30A – #10 AWG (3), Ø.74" [19mm] OD max.
- 20A – #12 AWG (3), Ø.64" [16mm] OD max.
- 16A – #14 AWG (3), Ø.41" [10.5mm] OD max.

### **4. Electrical Characteristics**

#### **4.1. Low Level Contact Resistance**

Measurements shall be performed using a (4) wire method with a maximum open circuit voltage of 20mV and a maximum test current of 100mA. Maximum contact resistance after environmental exposure shall not exceed 20mΩ.

- Test Voltage – 20mVDC maximum open circuit.
- Test Current – Not to exceed 100mA.

#### **4.2. Insulation Resistance**

With a mated pair of connector assemblies, measurement of the insulation resistance shall be more than 100MΩ. The following details shall apply:

- Test Voltage – 500VDC
- Electrification Time – 5 sec.
- Points of Measurement:
  - Conductor to Conductor
  - Conductor to Insert

#### **4.3. Dielectric Withstanding Voltage**

There shall be no evidence of arc-over, insulation breakdown or excessive leakage current (>3mA) when the connectors are mated. The following details shall apply:

- Test Voltage – 2000VAC
- Test Duration – 5 sec.
- Points of Measurement:
  - Conductor to Conductor

**SUBJECT: Engineering Product Specification  
Generation 2, J1772™ Connector / Inlet Cable Assembly****4.4. Temperature Rise**

The electrical contacts shall be designed for a maximum temperature rise of 50°C above ambient at rated load. The wiring insulation shall be rated for 105°C. For connectors rated less than 200A, the load is to be applied continuously. For connectors rated 200A or greater, the load is to be applied for 20 min. followed by a no-load period of 10 min. and repeated until peak temperature stabilizes.

**5. Mechanical Characteristics****5.1. Mating / Un-mating Forces**

The force to mate a coupler pair shall not exceed 75N total mating force. The following details shall apply:

- Cross Head speed – 10mm / minute
- Lubrication – None.
- Utilize free-floating fixtures.

**5.2. Contact Retention Force**

The contact retention force between contacts and inlet (housing) should be 22N min.

**5.3. Latch locking / unlocking Forces**

The force required to lock the latch over the inlet shall be 20N min. The connector shall have a latching mechanism to prevent inadvertent or accidental decoupling. The latching mechanism should provide a means in the connector to open the proximity detection conductor when disengaging from the vehicle inlet.

**5.4. Sealing Requirements**

Coupler system (connector and inlet), mated and un-mated, to meet UL50, Type 3R/3S, enclosure rating for degrees of environmental protection.

**6. Environmental Characteristics**

After exposure to the following environmental conditions (as specified in “Table 1 – Test Sequences” in accordance with the specified test procedure and/or details) the product shall show no physical damage and shall meet the electrical and mechanical requirements in Sections 4 and 5. Unless otherwise specified, product shall be mated during exposure.

**6.1. Thermal Shock**

With the connectors mated, the samples should be subjected to 5 consecutive cycles of thermal shock under the following conditions:

- -40°C for 1 hour
- +80°C for 1 hour

Change over time – 5 minutes max.

**SUBJECT: Engineering Product Specification  
Generation 2, J1772™ Connector / Inlet Cable Assembly****6.2. Humidity**

Unmated samples are to be condition dried in an oven @ 40°C ±5°C for 24 hours. The connector samples should then be mated and subjected to steady state humidity under the following conditions:

- Relative Humidity – 90-95%
- Temperature – 32°C ±2°C

Test Duration – 168 hours

**6.3. High Temperature Life Test**

Mated connector assemblies shall be placed in a temperature chamber and subject to a temperature of 105°C for 96 hours. Apply a 460VDC potential between conductors throughout the test.

**6.4. Vibration**

Mated samples are to be subjected to the following vibration profile:

**6.4.1 Frequency**

Varied from 10-55Hz. Return to 10Hz at a linear sweep period of 2 minutes / complete sweep cycle.

**6.4.2 Excursion**

1.0mm +0.1/-0.0 peak over the specified frequency range.

**6.4.3 Direction of Vibration**

Vertical axis of the vehicle inlet as it is mounted on the vehicle.

**6.4.4 Test Duration**

60 minutes +1/-0

**6.4.3 Pass / Fail Criteria**

After completion of the test, there shall be no observed rotation, displacement, cracking or rupture of parts of the device that could result in failure to operate as intended or cause to fail any other test requirements specified in this document. Cracking or rupture of the parts of the device that affect mounting shall constitute a failure.

**6.5. Mechanical Shock**

The test samples shall be subjected to the following shock:

- 100g peak Acceleration
- 8.6ms duration
- 3 shocks in each axis
- 6 directions

**6.6. Durability**

The coupler shall be designed to a minimum of 10k cycles of mechanical operation. Run (1) pair of connector assemblies thru 10k cycles at room temperature. Upon manual mating and un-mating of the connector assemblies, the mating forces must not increase to the point that normal human has difficulty mating them. After cycling, the devices shall not show any wear or deterioration that would impair further use.

**SUBJECT: Engineering Product Specification  
Generation 2, J1772™ Connector / Inlet Cable Assembly**

### **6.7. Salt Spray Mist**

With the connectors mated, the test should be conducted under the following conditions:

- Salt Concentration – 5%
- Test Duration – 48 hours
- Test Conditions – Atomization
- Temperature – 35°C

## **7. Quality Assurance Provisions**

### **7.1. Equipment Calibration**

All test equipment and inspection facilities used in the performance of any test shall be maintained in a calibration system in accordance with ISO 9000.

### **7.2. Inspection Conditions**

Unless otherwise specified, all inspections shall be performed under the following conditions:

- Temperature – 25°C ±5°C
- Relative Humidity – 30-60%
- Barometric Pressure – Local ambient

### **7.3. Sample Quantity and Description**

The test sequence for the qualification testing of the connectors, and sample size(s), are shown in Table 1. The minimum connector quantity to be tested are specified in the descriptions of each test.

### **7.4. Acceptance**

Electrical and mechanical requirements placed on test samples as indicated in the sections of this specification shall be established from test data using appropriate statistical techniques or shall otherwise be customer specified, and all samples tested in accordance with the product specification shall meet the stated requirements. Failures attributed to equipment, test set-up or operator error shall not disqualify the product. If product failure occurs, corrective action shall be taken and samples re-submitted for qualification.

### **7.5. Qualification Testing**

Qualification testing shall be performed on sample units with equipment and procedures normally used in production, using the test sequence in Table 1.



**SUBJECT: Engineering Product Specification  
Generation 2, J1772™ Connector / Inlet Cable Assembly**

**7.6. Qualification Test Sequence (per Table 1)**

The following connection points are to be tested for low-level contact resistance in Test Group(s) 1-4. Visual examination before any testing should confirm that the sample is not damaged or missing features. Visual examination after testing should confirm that the sample has not been damaged during testing except for the effects of the testing itself. All resistance measurements that are outside the limits should be confirmed before additional testing to assure that the measurements are correct.

		TEST GROUP			
		1	2	3	4
<b>No. of Connector Samples</b>		2 Pairs	2 pairs	1 Pair	2 Pairs
<b>TEST SEQUENCE</b>					
<b>Test</b>	<b>Paragraph</b>	Mating/Un-mating, Force & Salt Spray Mist	Thermal Shock & Humidity	Vibration & Mech. Shock	Hi-temp Life & Temp. Rise
Examination of product		1,6,12,18			
Mate connector(s)		2,7,13			
Un-mate connector(s)		11,17			
<b>ELECTRICAL CHARACTERISTICS</b>					
Low-level Contact Resistance <sup>1</sup>	4.1	3,8,10,14,16	3,5,9,13	3,5,7,9	3,5,10,12,14
Insulation Resistance <sup>1</sup>	4.2		6,10,14		
Dielectric Withstanding Voltage <sup>1</sup>	4.3		7,11,15		13
Temperature Rise (power contacts)	4.4				11
<b>MECHANICAL CHARACTERISTICS</b>					
Mating/Un-mating Force – 3 cycles	5.1				
Lock latch Mating/Un-mate Force – 3 cycles	5.2				
<b>ENVIRONMENTAL CONDITIONS</b>					
Thermal Shock	6.1		4		
Humidity	6.2		12		
High Temperature Life	6.3				4
Vibration	6.4			6	
Mechanical Shock	6.5			8	
Durability Cycles	6.6	9	8	4	9
Salt Spray Mist	6.7	15			

**8. Revision Record**

- 1/26/12 Rev.1 – Preliminary.
- 2/2/12 Rev.2 – Revised configurator.
- 2/21/12 Rev.A – Revised document number and Released.
- 3/19/12 Rev.B – Revised configurator and cable size. 75A was 80A.

\*\*\*\*\***END**\*\*\*\*\*

## Looking for pricing, stock, or lifecycle information?

Click below to explore more details on WIN SOURCE:

 [View J2CE4021-20 on WIN SOURCE](#)

 [ITT Cannon, LLC Information](#)

## Optimize Your Supply Chain with WIN SOURCE Solutions

-  Global Sourcing Solution
-  Obsolete Management
-  Cost Control Management
-  Shortage Management
-  Alternative Solution
-  Excess Inventory Management