

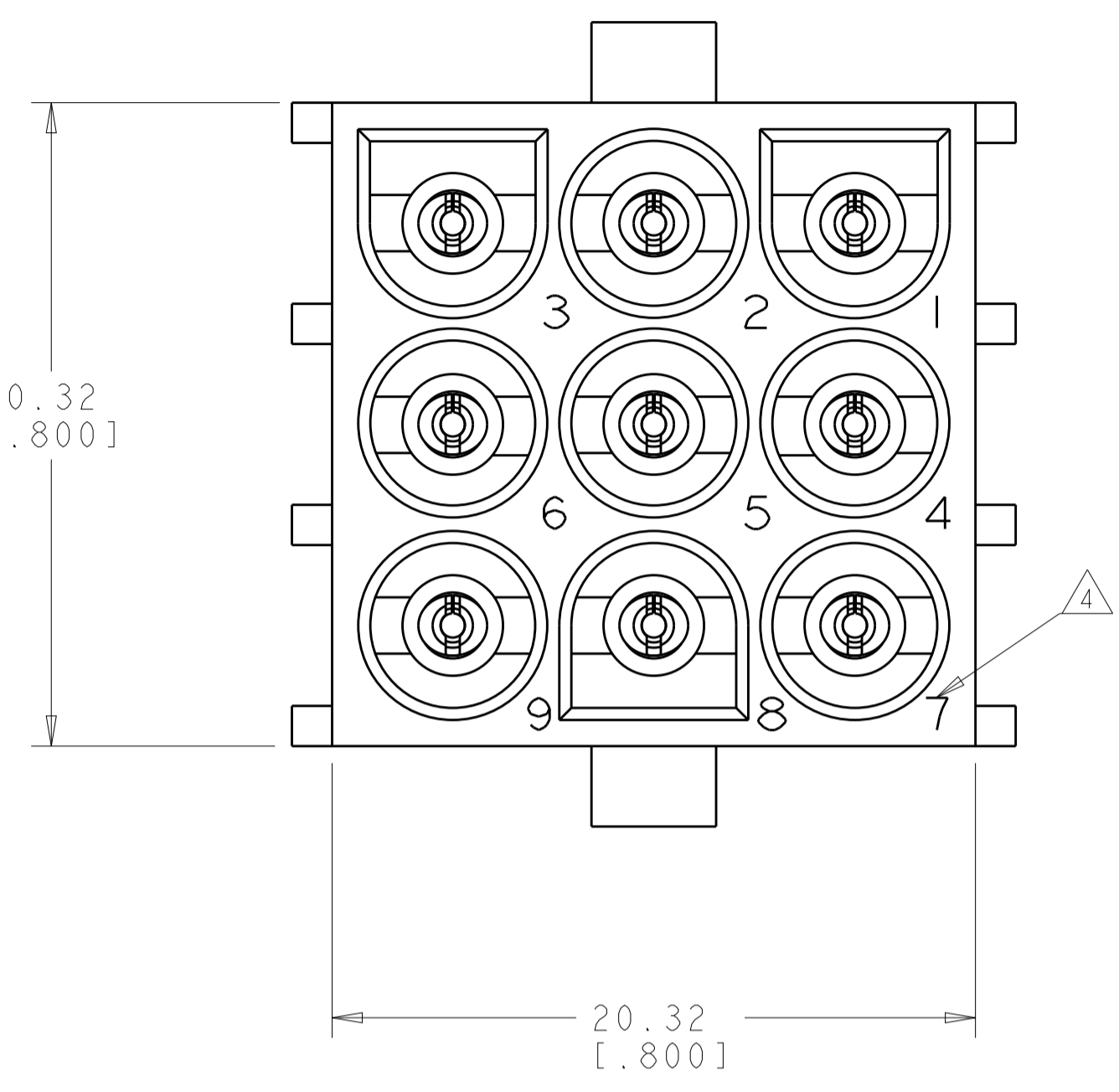

LOC	DIST	REVISIONS					
		P	LTN	DESCRIPTION	DATE	DWN	APVD
CM	00	W2		REVISED PER ECR-12-011660	24JAN2013	KH	TM

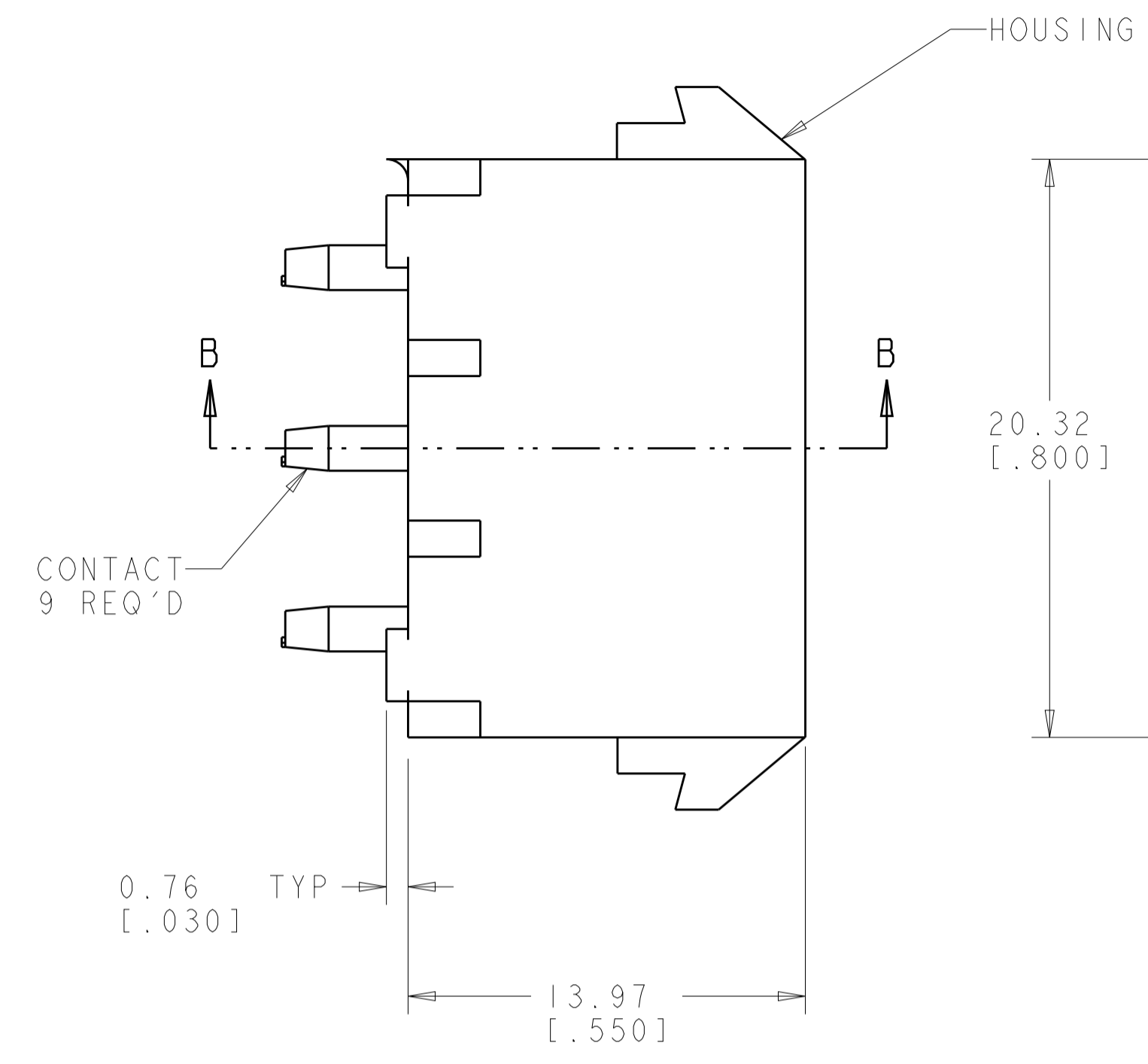

- PARTS COMPLY TO AMP SOLDERABILITY SPECIFICATION 109-11-3.
- CONTACT IS PLATED OVERALL WITH 0.00127 [.000050] NICKEL, THEN 0.00076 [.000030] GOLD OVER CONTACT LENGTH INDICATED AND TIN LEAD ON SOLDER TAIL END.
- MATES WITH HOUSING 480706.
- CIRCUIT IDENTIFICATION CHARACTERS ARE ADJACENT TO THE INDICATED CAVITIES, BUT LOCATION AND ORIENTATION MAY DIFFER FROM PRINT.
- CONTACT IS PLATED OVERALL WITH 0.00127 [.000050] NICKEL, THEN 0.00076 [.000030] GOLD OVER CONTACT LENGTH INDICATED AND MATTE TIN ON SOLDER TAIL END.
- DIMENSIONS IN BRACKETS ARE IN INCHES.
- SUPERSEDED BY 350432-4

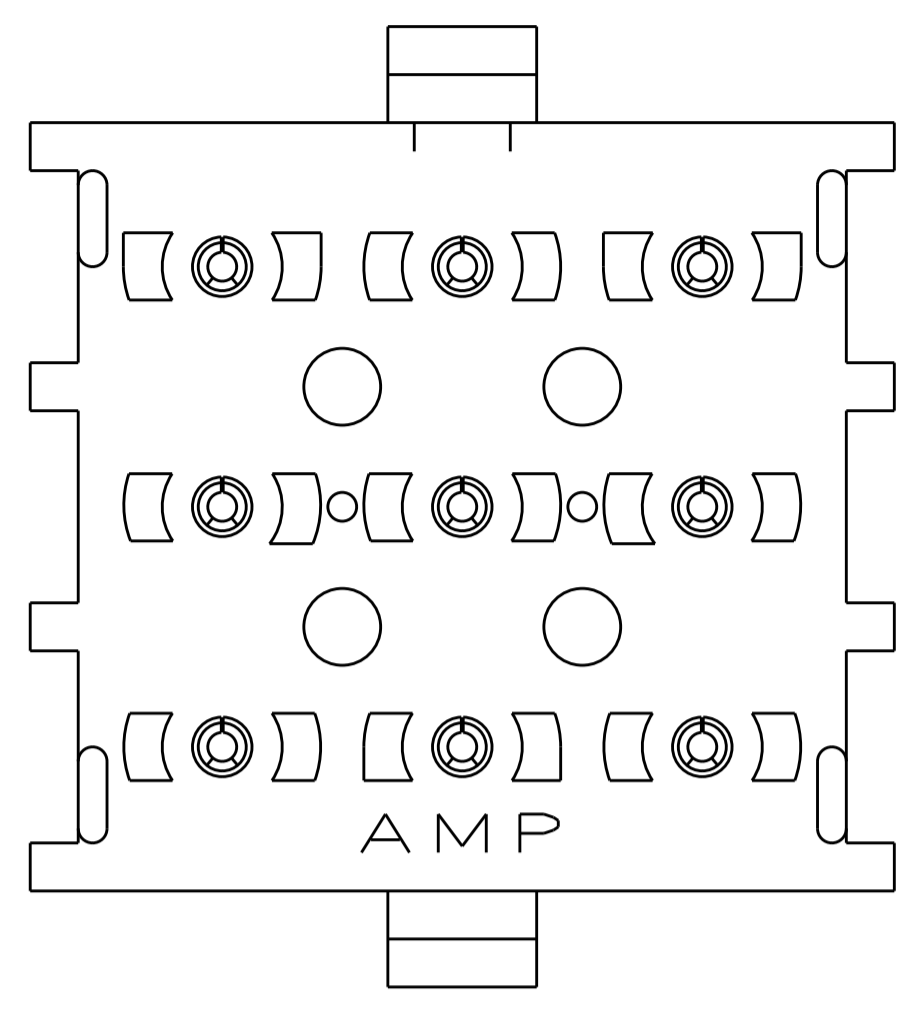
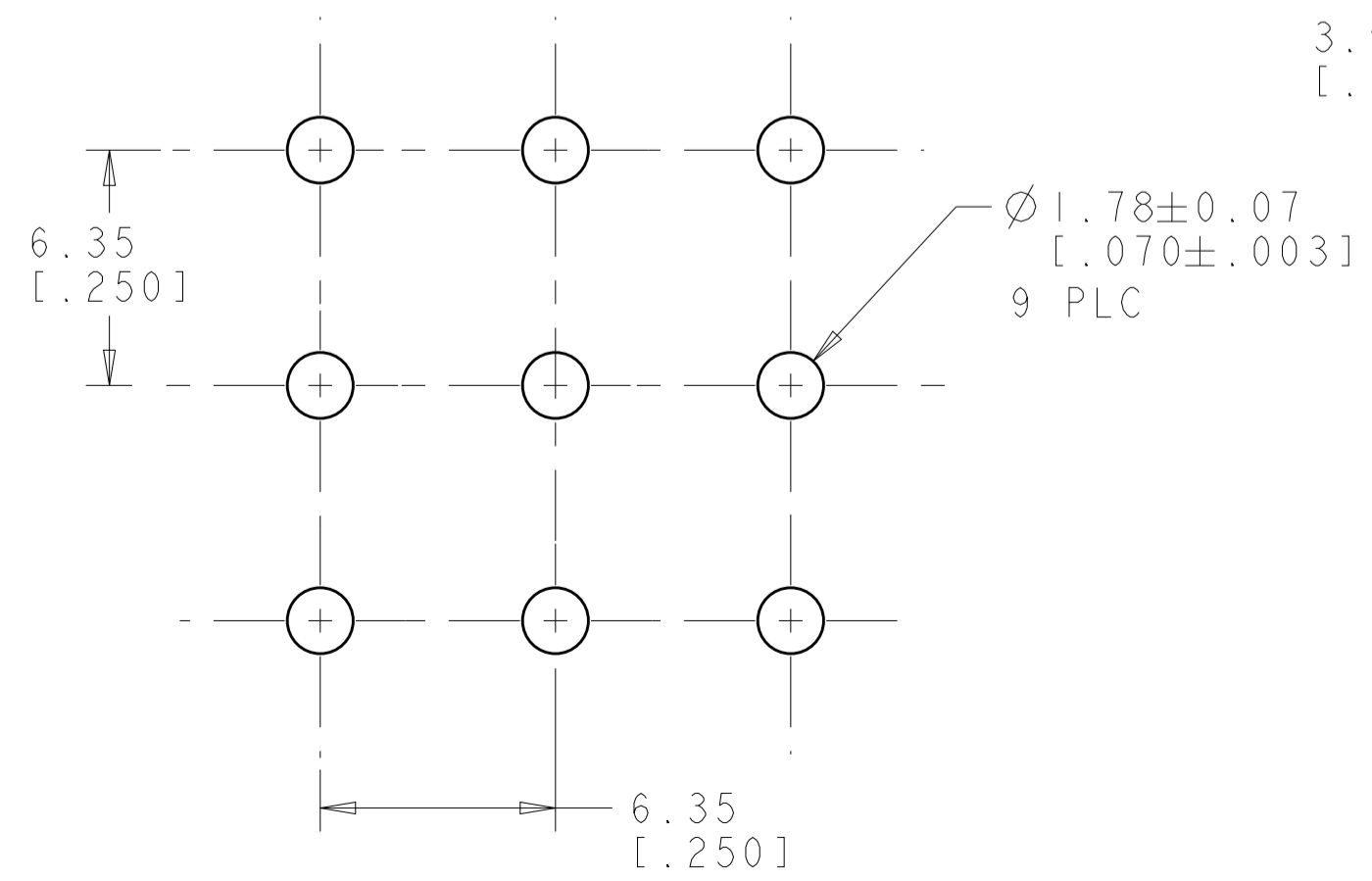
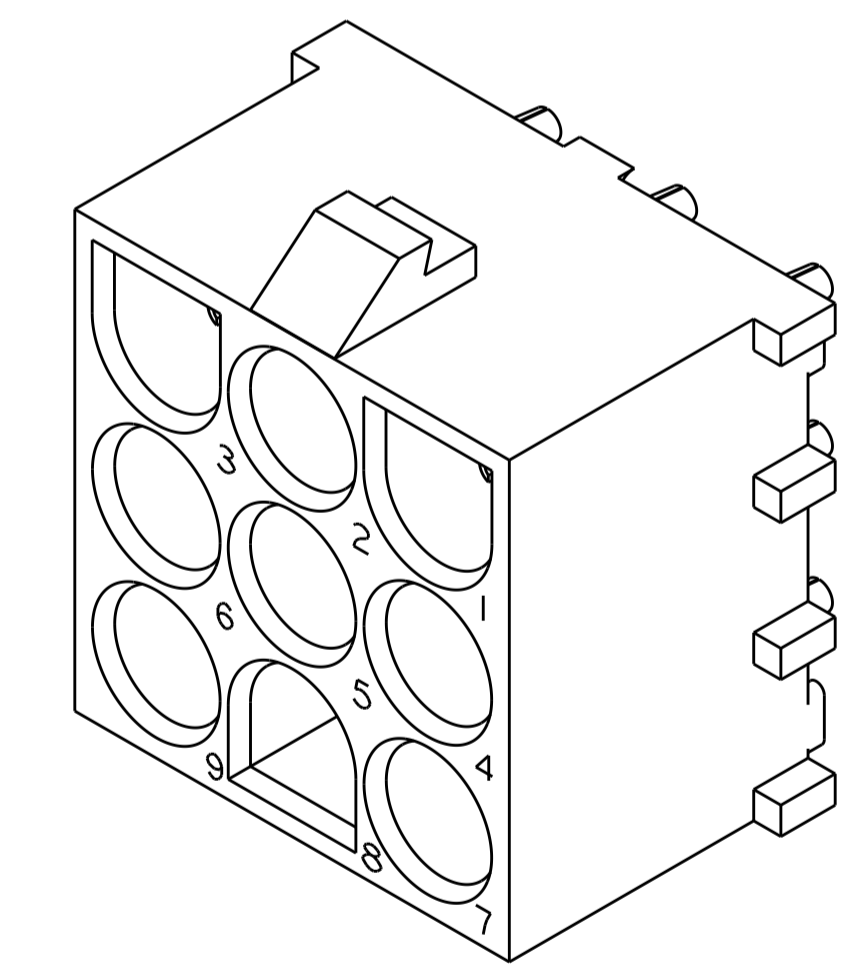
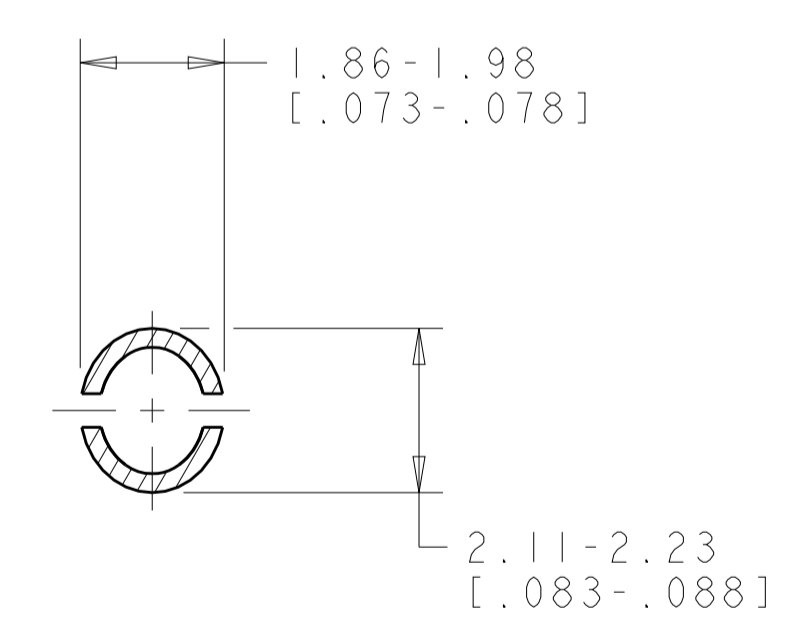
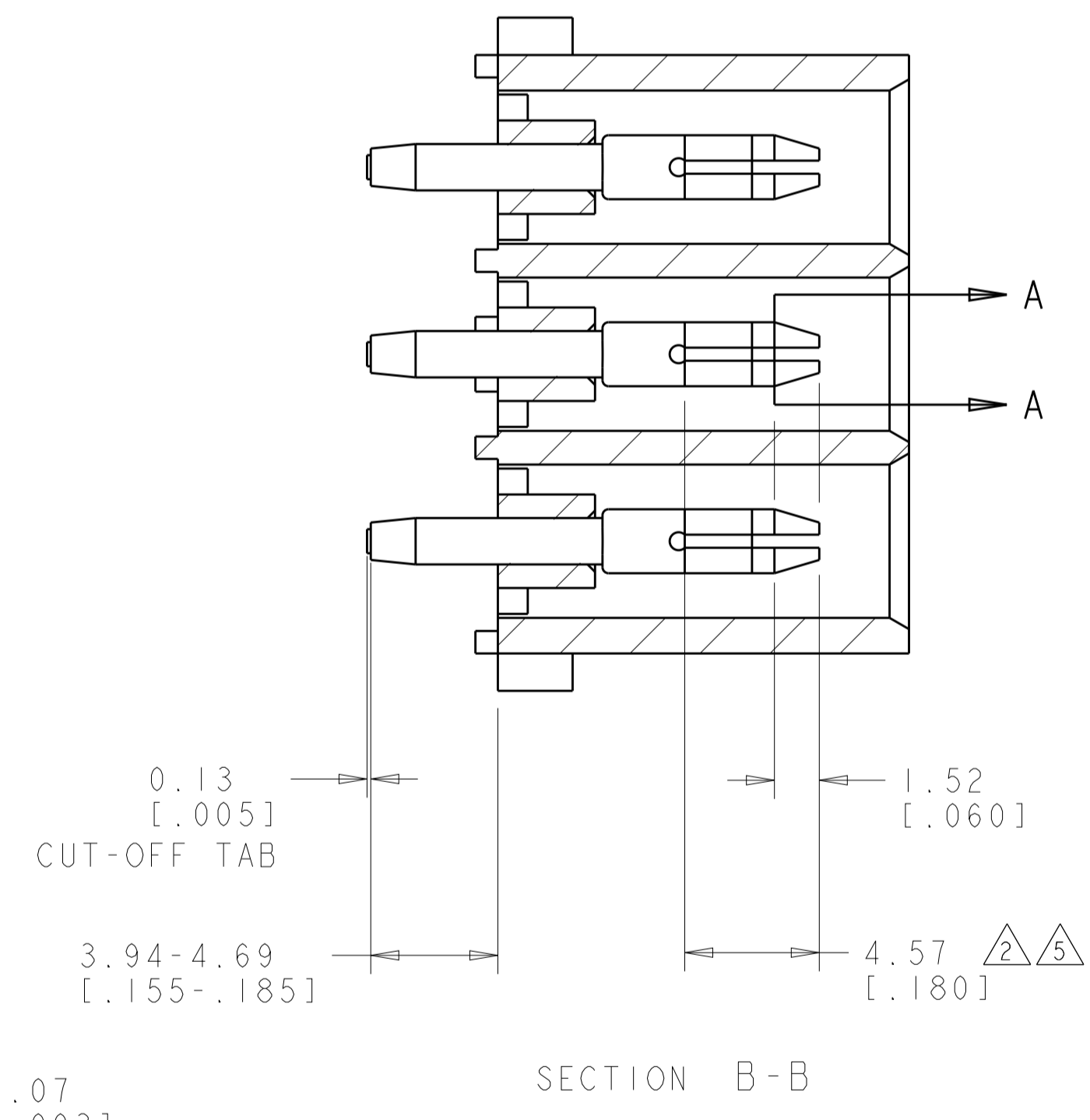

RECOMMENDED MOUNTING HOLE PATTERN FOR 1.57 [.062] THICK P.C. BOARD

PHOSPOR BRONZE, GOLD	NYLON, UL94V-2, NATURAL	350432-4
PHOSPOR BRONZE, GOLD	NYLON, UL94V-2, NATURAL	350432-2
PHOSPOR BRONZE, PRE-TIN	NYLON, UL94V-2, NATURAL	350432-1
PIN CONTACT MATERIAL AND FINISH	HOUSING MATERIAL AND COLOR	PART NUMBER

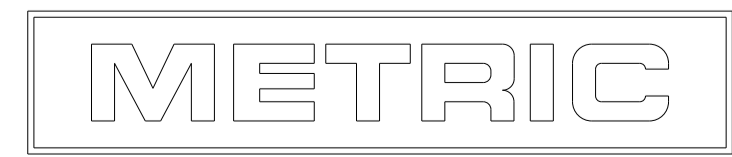

THIS DRAWING IS A CONTROLLED DOCUMENT.		DWN: 19JULY2005	TE Connectivity
DIMENSIONS: mm [INCHES]		CHK: WHITAKER 19JULY2005	
TOLERANCES UNLESS OTHERWISE SPECIFIED:		S. RIDGILL 19JULY2005	
0 PLC ± 1 PLC ±0.131(.005) 2 PLC ± 3 PLC ± 4 PLC ± ANGLES ±40°30'		APVD: S. RIDGILL 19JULY2005	
MATERIAL: SEE TABLE	FINISH: SEE TABLE	NAME: S. RIDGILL	PRODUCT SPEC: -
		APPLICATION SPEC: -	RESTRICTED TO: -
		WEIGHT: -	SIZE: A1
		CUSTOMER DRAWING	CAGE CODE: 350432
		SCALE: 5:1	SHEET: 1 OF 1
			REV: W2

## Looking for pricing, stock, or lifecycle information?

Click below to explore more details on WIN SOURCE:

 [View 350432-1 on WIN SOURCE](#)

 [TE Connectivity](#) Information

## Optimize Your Supply Chain with WIN SOURCE Solutions

-  Global Sourcing Solution
-  Obsolete Management
-  Cost Control Management
-  Shortage Management
-  Alternative Solution
-  Excess Inventory Management