



# THE DATASHEET OF BCR402W 24V LED BOARD





# LED lighting

Semiconductors for power conversion & smart lighting

[www.infineon.com/lighting](http://www.infineon.com/lighting)



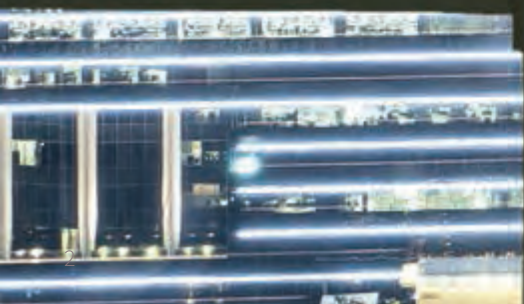
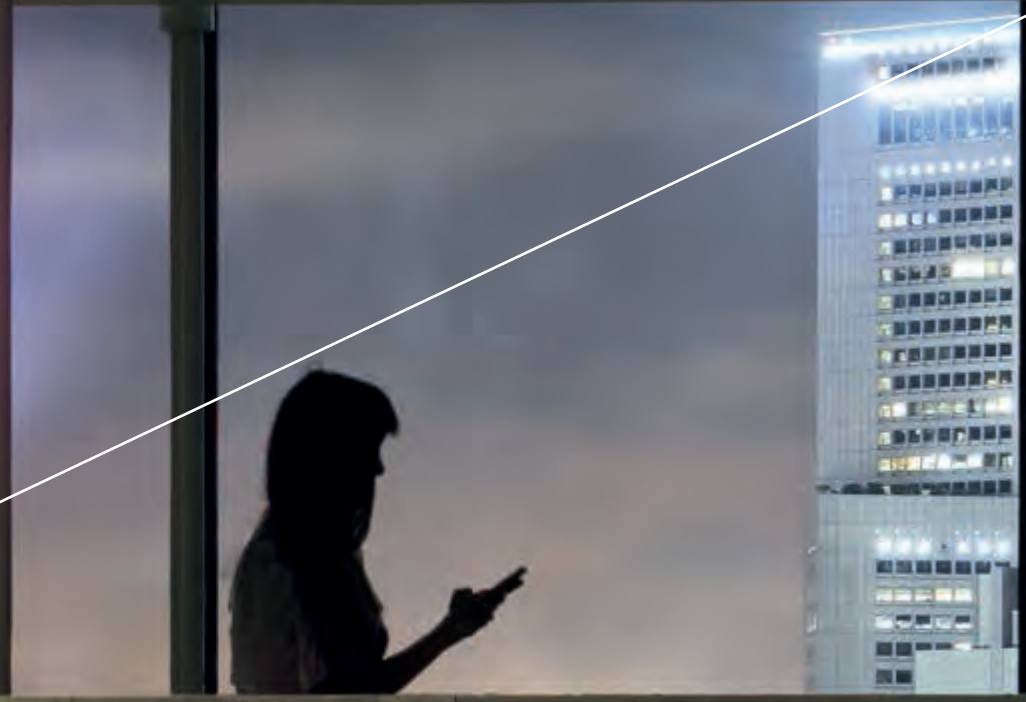

# Contents

<b>Introduction</b>	<b>4</b>	<b>LED strips &amp; multichannel LED applications</b>	<b>35</b>
<b>LED drivers</b>	<b>5</b>	<b>Linear LED driver ICs</b>	36
<b>LED driver ICs</b>	6	Driving low-power LEDs with BCR402W	37
ICL5101 – PFC-LLC combo controller	6	Driving mid-power LEDs with BCR320U	38
IRS2982S – multimode PFC/flyback controller	7	<b>DC/DC LED driver ICs</b>	39
IRS2505L – low-cost PFC IC	8	Driving high-power LEDs with ILD6070/6150	40
ILD2111 – digital DC/DC buck controller	9	Advanced thermal protection with the ILD6000 family	41
ICL8105 – multimode PFC/flyback controller for 0–10 V dimming	10	Driving high-power LEDs with ILD4035	42
.dp Vision	11	Driving high-power LEDs with ILD4001	43
<b>0–10 V dimming interface IC</b>	12	<b>LED retrofit lamps</b>	<b>44</b>
<b>XMC™ microcontrollers for intelligent LED drivers</b>	13	ICL8201 – AC/DC buck controller in combination with 500 V CE for LED tubes and lamps	45
<b>CoolMOS™ – high-voltage MOSFETs</b>	16	<b>CoolMOS™ CE – focus on efficiency, cost-effectiveness and part availability</b>	46
CoolMOS™ for lighting applications	17	<b>CoolMOS™ CE in an SOT-223 package</b>	46
CoolMOS™ CE – focus on efficiency, cost-effectiveness and part availability	18	<b>Support tools</b>	<b>49</b>
CoolMOS™ CE in an SOT-223 package	18	<b>LightDesk: lighting selection &amp; design tool</b>	49
600 V CoolMOS™ P6 series	21	<b>Evaluation boards &amp; kits</b>	50
CoolMOS™ supply chain – delivery reliability, flexibility and supply security	22		
<b>OptiMOS™ – medium-voltage MOSFETs</b>	24		
<b>Light management</b>	<b>26</b>		
<b>Microcontrollers for LED lighting</b>	27		
XMC1000 family	27		
LED lighting application kit	28		
RGB LED lighting shield for Arduino	28		
XMC™ LED current control explorer	29		
Superior flicker and color control thanks to the Brightness & Color Control Unit (BCCU)	30		
<b>DAVE™ teams up with the well-established ARM® ecosystem</b>	31		
<b>Radar sensors</b>	32		
24GHz radar demonstrator kit for presence detection	32		
<b>Secured smart lighting – counterfeit protection and a secured network</b>	34		

# Addressing the key needs and value drivers for LED lighting

Besides offering huge energy-saving potential, LED lighting is also getting smarter and more human-centric. Some companies are even going beyond human-centric lighting, using the lighting infrastructure to offer services that go far beyond lighting. It is likely that we will see lighting playing an essential part in what are commonly referred to as smart homes, smart buildings and smart cities.

Our products and solutions range from LED driver ICs and MOSFETs suited for LED drivers, to microcontrollers, sensors and hardware that can be used to enable secure communication.

In addition to products with proven quality, a highly competent global lighting team – complemented by our channel partners – will provide you with the necessary support to design products and systems for LED lighting.

## Our range of products & solutions stretches from

- > LED driver ICs that support a platform approach for LED drivers in commercial indoor & outdoor lighting
- > Comprehensive portfolio of high-voltage MOSFETs (CoolMOS™) & low-voltage MOSFETs (OptiMOS™)
- > Benchmark for linear- & switch-mode LED driver ICs for multi-string LED applications
- > Microcontrollers with dedicated peripherals for intelligent lighting allow full flexibility in design and product portfolio management by combining various aspects of intelligent lighting systems, such as power conversion, communication and dimming technologies as well as easy-to-use, fully flexible color mixing functionality
- > Sensor solutions for presence detection to generate additional energy savings
- > Low-cost LED driver ICs for LED retrofit lamps

## Power conversion light management

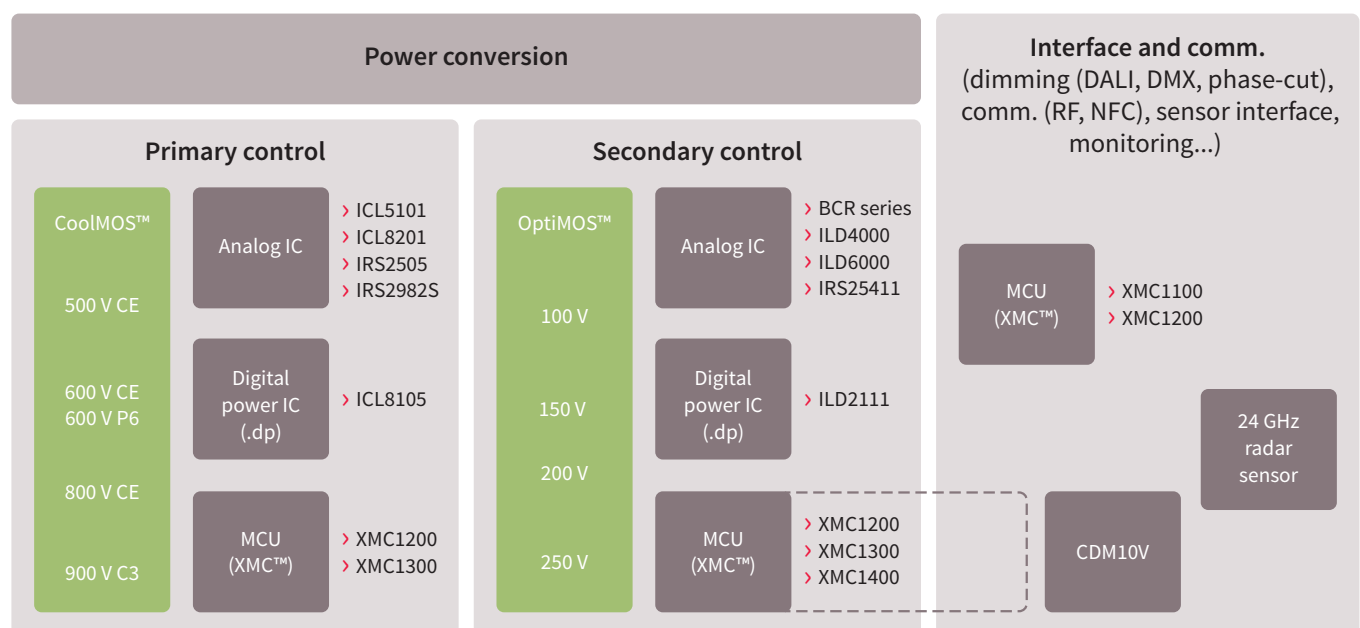



## LED drivers

LED drivers are used to provide a constant current to LED light engines for several applications, such as commercial indoor lighting, street lighting & high bay lighting.

The requirements of such applications in terms of efficiency, power factor, total harmonic distortion and system lifetime are usually much higher than for LED retrofit lamps.

For the power conversion in LED drivers, numerous topologies are deployed by different companies. For power ratings below 50 W, single-stage flyback topology including power factor correction is quite common. As the power rating increases, LED drivers with a dedicated stage for power factor correction and a dedicated stage for flyback or LLC become more common. Other common topologies include a single-stage flyback with a primary constant voltage and secondary buck with constant current output. Depending on the end applications, dual-stage non-isolated topologies, such as PFC and buck, are also used.

The type of topology used very often depends on the features that are implemented as well as the platform concept being used by the specific company. The company's particular expertise in the dedicated area is also an important factor.

Taking into account that there is no single dominant topology in the LED driver market, we offer LED driver ICs that support several different topologies, as well as features. Other important factors in the LED driver market include increasing cost pressure and time to market.

Cost is related to

- › Bill of material
- › Product variants involving additional costs due to stock-keeping and R&D

Our products for LED drivers range from analog LED driver ICs that are tailored for specific applications, to configurable digital ICs that can accelerate the time to market, and last but not least, to microcontrollers that offer the highest degree of flexibility.

# LED driver ICs

## ICL5101 – PFC-LLC combo controller

The ICL5101 integrates a half-bridge controller with a PFC stage in a single package. The high level of integration assures a low number of external components, enabling small form factor designs ideal for compact power supplies in lighting applications, such as LED drivers. All operation parameters of the IC are adjustable via simple resistors, being the ideal choice for an affordable and reliable configuration. A comprehensive set of protection features, including an adjustable external overtemperature protection and capacitive load protection, ensures the detection of fault conditions to increase the system safety.

### Features and benefits

- > Constant voltage or constant current control
- > PFC in CCM mode during nominal load and DCM mode in low-load condition down to 0.1% for operation without audible noise
- > High-power quality with  $PF > 0.96$ ,  $THD < 10\%$
- > Allows secondary-side IC dimming down to 1%
- > PFC/LLC combo IC allows the best matching of PFC stage and LLC stage timing control
- > Supports a wide input voltage range from 90–305 V

### ICL5101 – block diagram

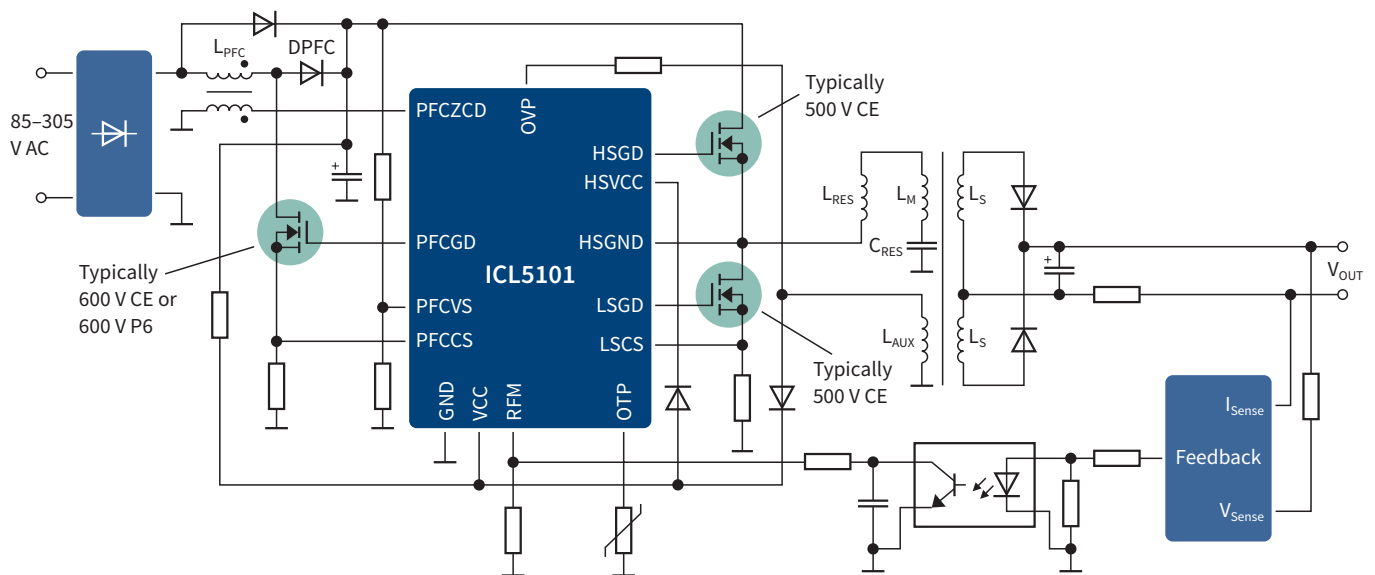

### Related application note

Info number	Description
ICL5101-AN-v02_02-EN	110 W / 54 V power supply demoboard using ICL5101 in PFC & LLC topology

### Related evaluation board

Board name	Product	Description	Order number
Evaluation board ICL5101	ICL5101, CoolMOS™ MOSFET CE and E6	PFC/LLC evaluation board 110 W LED driver	EVALLDCL5101E1

## IRS2982S – multimode PFC/flyback controller

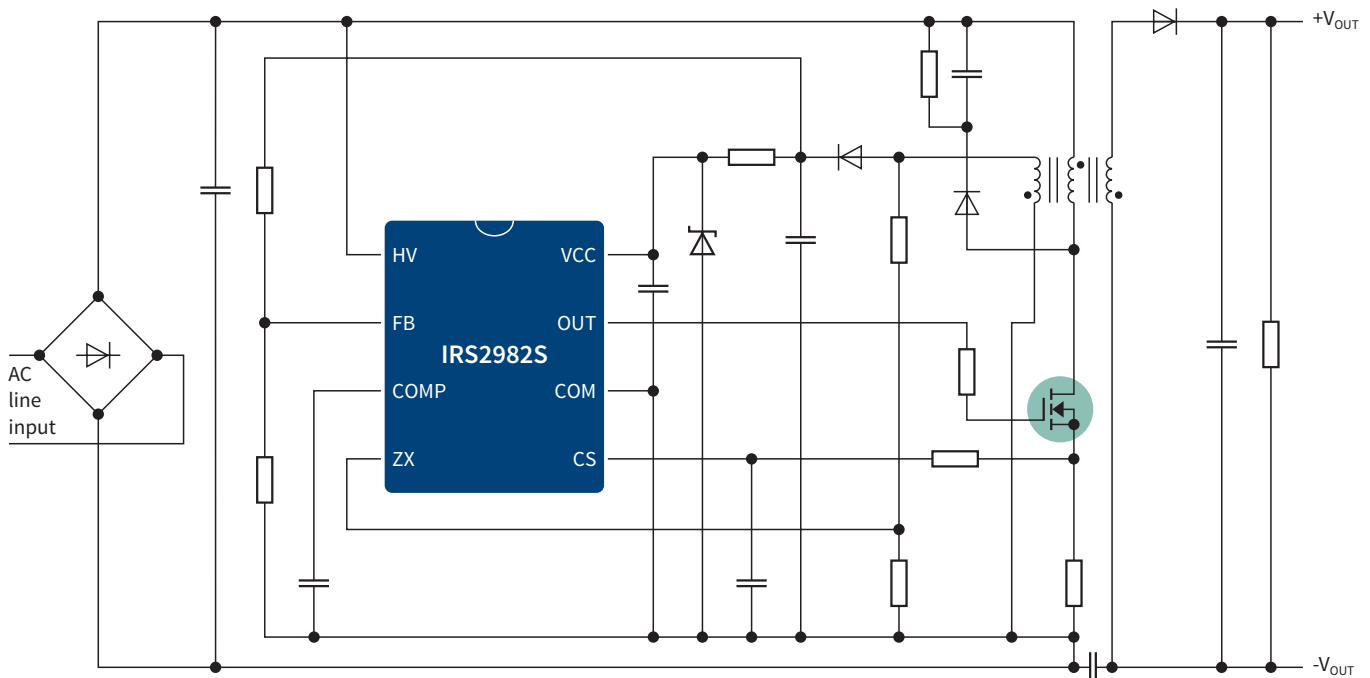

### Features and benefits

- > 600 V high-voltage rapid startup-to-light within 0.5 s
- > Direct feedback – highly accurate regulation
- > High power factor and low THD
- > Critical Conduction Mode (CrCM)
- > DCM operation at light loads (minimum off-time)
- > Burst-mode operation at very light loads or open-circuit output
- > Overvoltage protection
- > TRIAC dimming option
- > Constant voltage in isolated flyback; constant current in non-isolated flyback

### Related application note

#### Description

50 W Flyback converter design using the IRS2982S controller

### Related evaluation board

Board name	Product	Description
IRXLED04 50W Flyback eval board	IRS2982S, CoolMOS™ MOSFET 800 V CE	50 W Flyback converter design using the IRS2982S controller

## IRS2505L – low-cost PFC IC

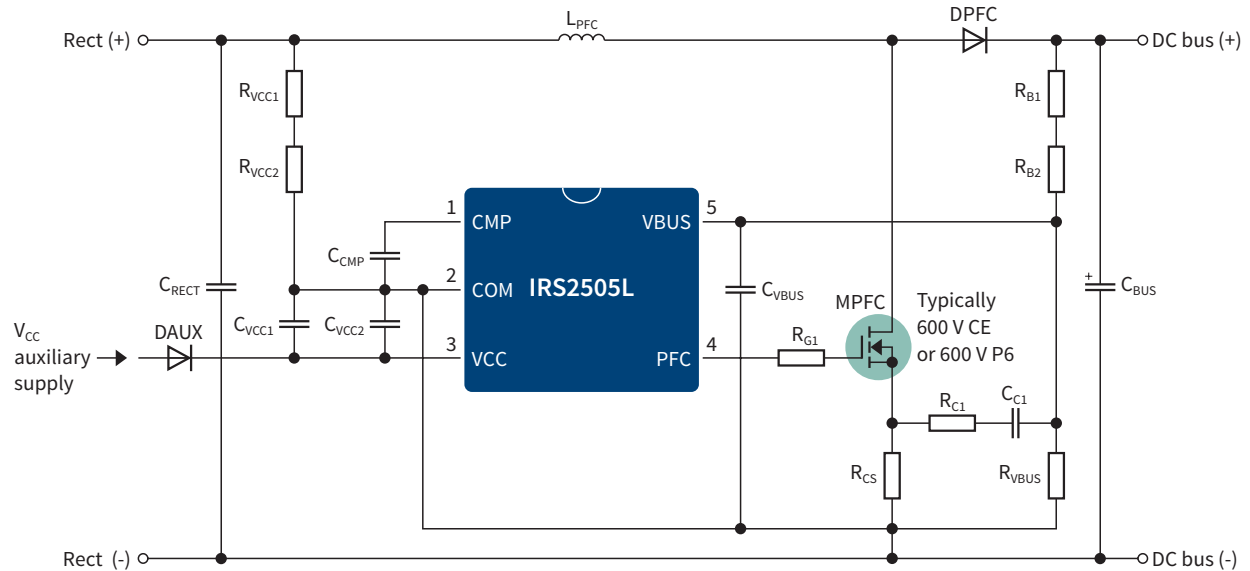

## Features and benefits

- › SOT23-5 package, 70% smaller than a conventional SO8 package
- › High power factor and ultra-low THD over a wide input range
- › 5-pin boost PFC and SMPS driver controller
- › PFC inductor auxiliary winding not necessary
- › Critical Conduction Mode (CrCM) operation – low switching losses
- › Output overvoltage protection
- › Zero-crossing sensed via the gate drive
- › Gate driver optimized to eliminate switch-off diode
- › Cycle-by-cycle overcurrent protection
- › Micro-power start-up – very low start-up losses

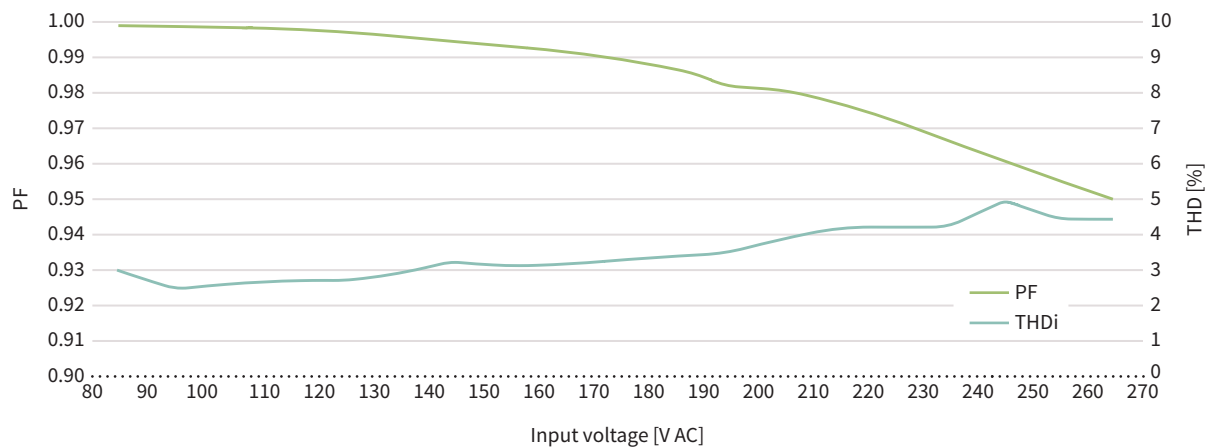

## ILD2111 – digital DC/DC buck controller

The ILD2111 is a high-performance configurable buck controller, designed as a constant current source with hysteretic output current regulation. The IC supports output current setting by the end user with a simple resistor. Important parameters, such as current assignment and protection features, can be configured via a dedicated single-pin UART interface. The ILD2111 buck controller can be dimmed via an external PWM signal. The controller typically uses a low-side switch buck topology operating in a Continuous Conduction Mode (CCM). The device automatically selects an optimal operating window with respect to switching frequency and output current ripple. This ensures highest efficiency under various application conditions. This characteristic can be customized via several parameters. The controller provides protection features against overload, open- and short-load conditions, as well as intelligent overtemperature protection.

### Applications

- › LED drivers typically from 10–150 W, e.g. dual-stage professional lighting systems
- › Integrated electronic control gear for LED luminaries

### Features and benefits

- › Scalable DC input voltage from 2.5 V to 1.6 kV
- › Wide output range, e.g. 15–55 V DC
- › The IC supports output current setting by the end user with a simple resistor
- › Important parameters, such as output current assignment and protection features, can be configured digitally
- › Flicker-free and phase-aligned PWM dimming to 1%
- › The device automatically selects an optimal operating window with respect to switching frequency and output current ripple

### ILD2111 – small BoM due to smart system partitioning

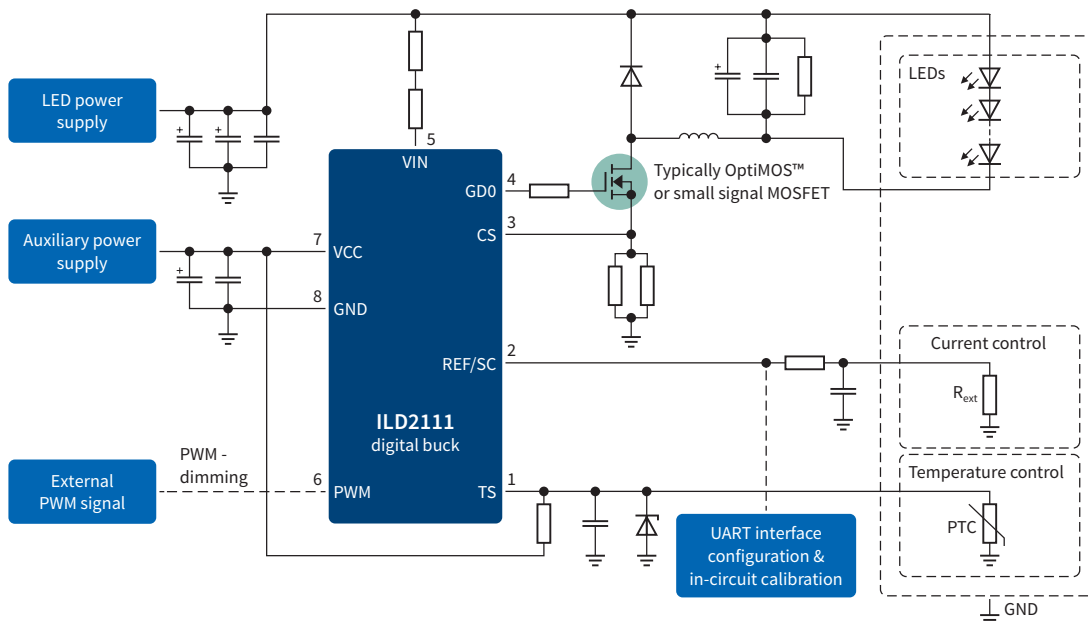

### Related application note

Info number	Description
Infinion-ILD2111_Evaluation_System_Getting_Started_-AN-v01_00-EN	ILD2111 evaluation system getting started

### Related evaluation board

Board name	Product	Description	Order number
Evaluation board ILD2111	ILD21111 .dp digital power 2.0	Evaluation board output current from 250–800 mA for LED driver	EVALLD2111E1

## ICL8105 – multimode PFC/flyback controller for 0-10 V dimming

The ICL8105 is a high-performance configurable single-stage flyback controller with Power Factor Correction (PFC) for constant current output LED drivers. The digital core of the ICL8105, along with its advanced control algorithms, provide multi-operation modes, such as quasi-resonant mode, discontinuous conduction mode or active burst mode. Thanks to this functionality and a smooth transition between the operation modes, the controller delivers high efficiency, high power factor and low harmonic distortion through the entire load range. The optional active burst-mode control scheme significantly extends the dimming range and is aligned to the line frequency, thereby avoiding effects such as flicker or shimmer while also reducing the audible noise.

### Applications

- › LED drivers from 10–80 W

### Features and benefits

- › Wide input voltage, e.g. 90–305 V AC
- › Wide output range, e.g. 15–55 V DC
- › Smooth operation with extended dimming capability
- › Fast engineering and simplified variant handling during production
- › Isolated 0–10 V dimming with a configurable dimming curve
- › Intelligent thermal management
- › Small BoM due to primary-side control and high level of integration

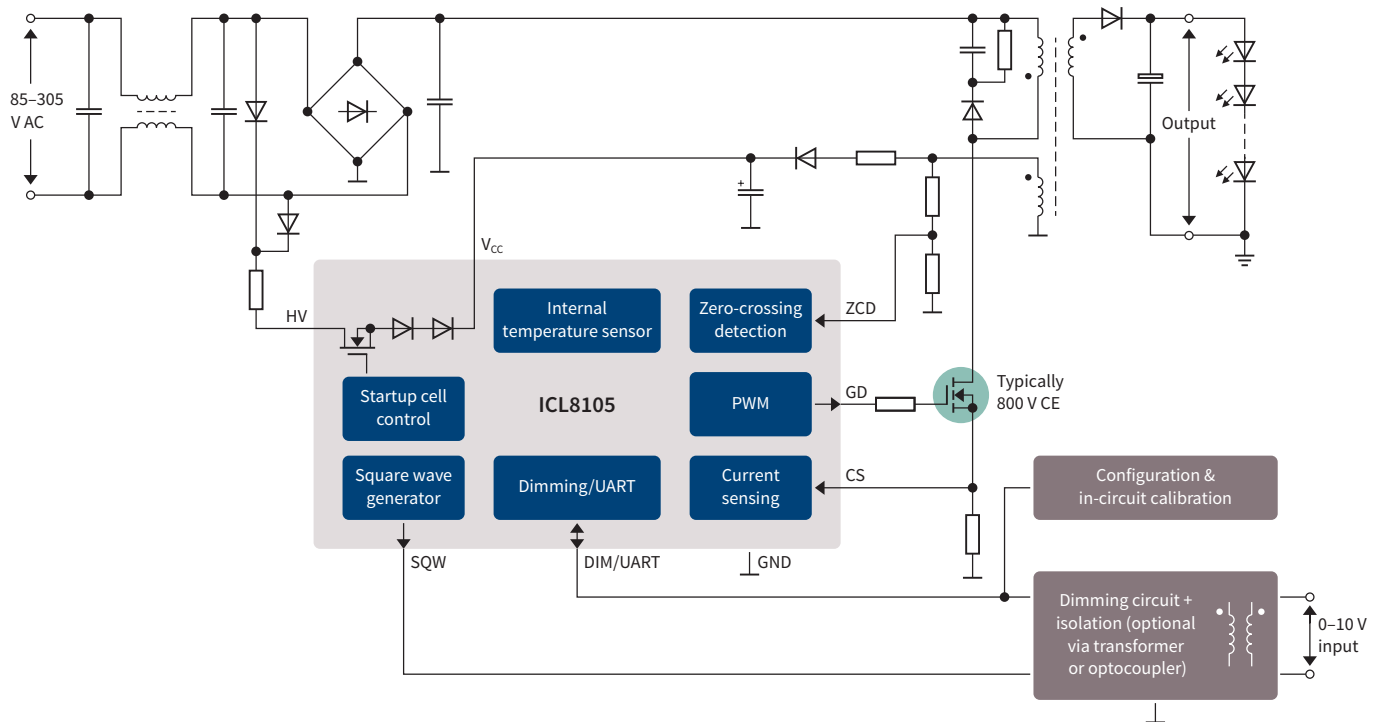

### Related application note

Info number	Description
Infineon-ICL8105_40W_Demoboard_Application-AN-v01_00-EN	40 W demoboard with isolated 0–10 V dimming interface
Infineon-ICL8105_Evaluation_System_Application_Note-AN-v01_00-EN	System application note

### Related evaluation board

Board name	Product	Description	Order number
Evaluation board ICL8105	ICL8105 .dp digital power 2.0	Evaluation system board 20–80 W for LED driver	EVALLEDICL8105E1
Demoboard ICL8105	ICL8105 .dp digital power 2.0	Demoboard 40 W for LED driver	EVALLEDICL8105F2

## .dp Vision

### This GUI simplifies your design

.dp Vision is a Graphical User Interface (GUI) for the parameter configuration and programming of Infineon .dp digital power 2.0 ICs for evaluation purposes. With .dp Vision software, the parameters of .dp products can be easily adapted to suit application requirements. .dp Vision supports configuration of the following parameters: hardware configuration, protections, temperature guard, startup & shutdown, control loop, dimming, multimode, enhanced PFC and fine-tuning. The .dp device is connected via USB to a computer using the .dp Interface Gen2 hardware, which is a galvanic isolated and certified interface board.



### Features and benefits

- › Set parameter and protection behavior for .dp products
- › Test parameters temporarily
- › Burn parameters permanently
- › Automatic update of firmware on .dp Interface Gen2
- › Online update functionality keeps .dp Vision up-to-date
- › Assistant functionality for guiding a user through a typical parametrization flow

### Further advantages

- › Comfortable parameter setting without changing components on hardware
- › Maximum flexibility for adapting application behavior via parameters
- › Optimize system performance
- › Reduced R&D efforts

.dp Vision and .dp Interface board available via [www.hitex.com/dp](http://www.hitex.com/dp)

# 0–10 V dimming interface IC

CDM10V – CoolestDiMming solution for 0–10 V

CDM10V is a fully integrated 0–10 V dimming interface IC and comes in a very small 6-pin SOT package to enable small form factor designs with LED drivers. The device is targeted at various dimming applications in the field of lighting. This IC can be used to transmit analog voltage-based signals from a 0–10 V dimmer or potentiometer to the dimming or PWM input of a lighting controller IC in the form of a current-based PWM signal to drive an external optocoupler. It's an ideal fit for Infineon's ICL8105. The CDM10V IC outputs a 0–100% PWM current signal at a configurable frequency with an amplitude of 5 mA. The duty cycle of the PWM signal can be limited to a defined minimum value (configurable). Embedded digital signal processing ensures minimum variations from device to device.

## Features and benefits

- › CDM10V replaces up to 25 discrete components in a traditional 0–10 V dimming solution
- › Increases reliability and enables smaller designs due to high integration into a small SOT23-6 package
- › Only integrated solution on the market
- › Supports active and passive dimming
- › Preset values for
  - Dimming range – 5%
  - PWM frequency – 1 kHz
  - Dimmer current – 200  $\mu$ A
- › All three parameters configurable in accordance with customer and application needs
- › Optional Dim-to-Off capability (configurable), one solution for various applications. The one-time programming interface allows a wide range of configurations
- › Transparent PWM mode allows the transmission of PWM signals from secondary to primary side

## CDM10V – block diagram

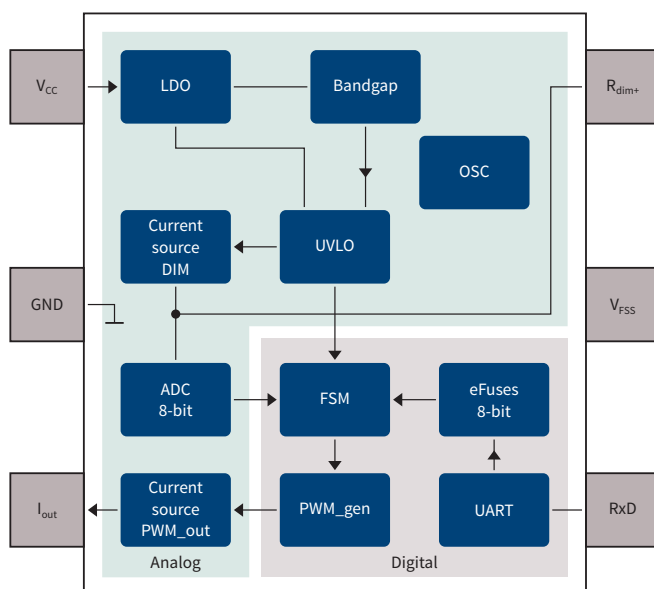

## Isolated interface dimming IC

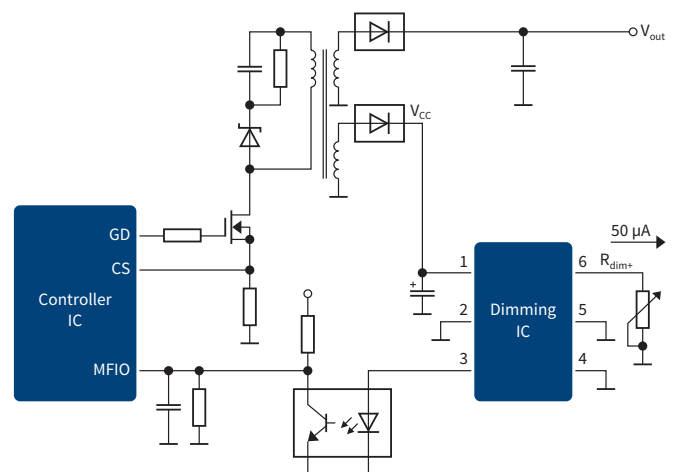

## Related evaluation board

Board name	Product	Description	Order number
CoolDim10V Demoboard	CDM10V, ICL8105	CoolDim10V demoboard	SP001493168

# XMC™ microcontrollers for Intelligent LED drivers

The XMC1000 family of ARM® Cortex®-M0-based industrial microcontrollers offers a broad portfolio of microcontrollers with dedicated peripherals for LED lighting which are designed to cover a range of use cases and different topologies for lighting applications requiring advanced features.

## Applications

- > Multichannel, connected DC/DC LED drivers with high-precision dimming (down to 0.1%) and advanced color mixing
- > Intelligent and connected AC/DC LED driver stages, adding advanced communication, dimming and protection features

## Features and benefits

- > High quality of light
- > Flexible and efficient power conversion using different control schemes (constant ON time, constant OFF time, quasi-resonance)
- > Communication and sensing
- > Software IP protection

DC/DC application example: 4-channel DC/DC RGBW LED driver with DALI, DMX512 communication and different sensing options

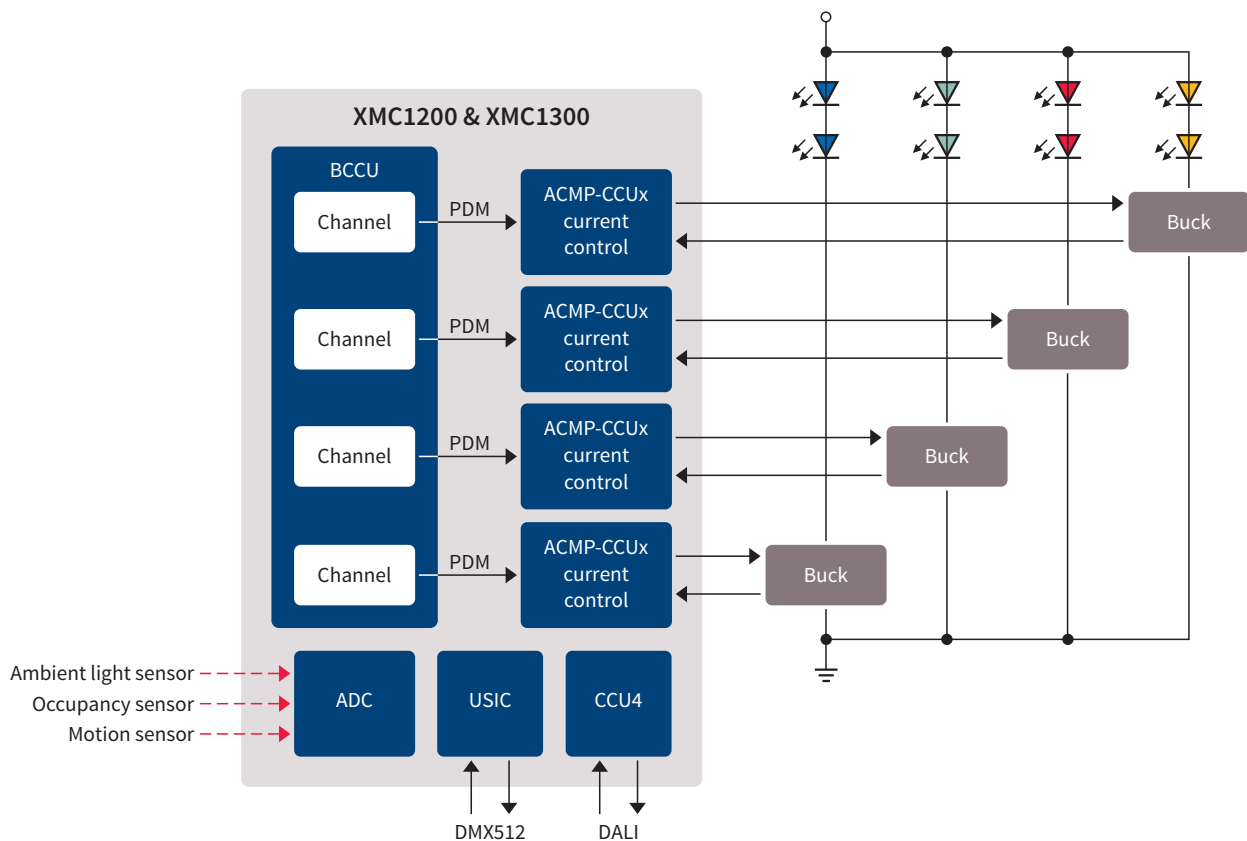

## AC/DC application examples with XMC™

See below for an illustration of two examples of how XMC™ MCUs can enhance traditional lighting power supply topologies by adding additional features such as DALI or DMX512 communication, or phase-cut dimming.

### AC/DC application example 1: single-channel flyback PFC constant current LED driver with DALI, 0–10 V and phase-cut dimming option

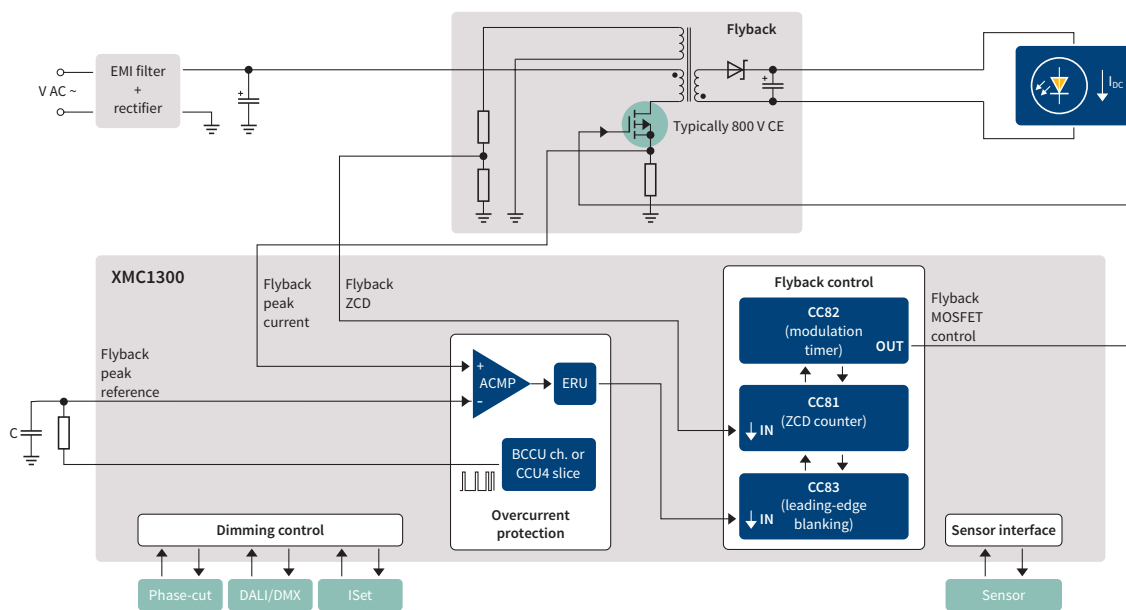

### AC/DC application example 2: 2-channel flyback PFC constant current LED driver with DALI, 0–10 V and phase-cut dimming option

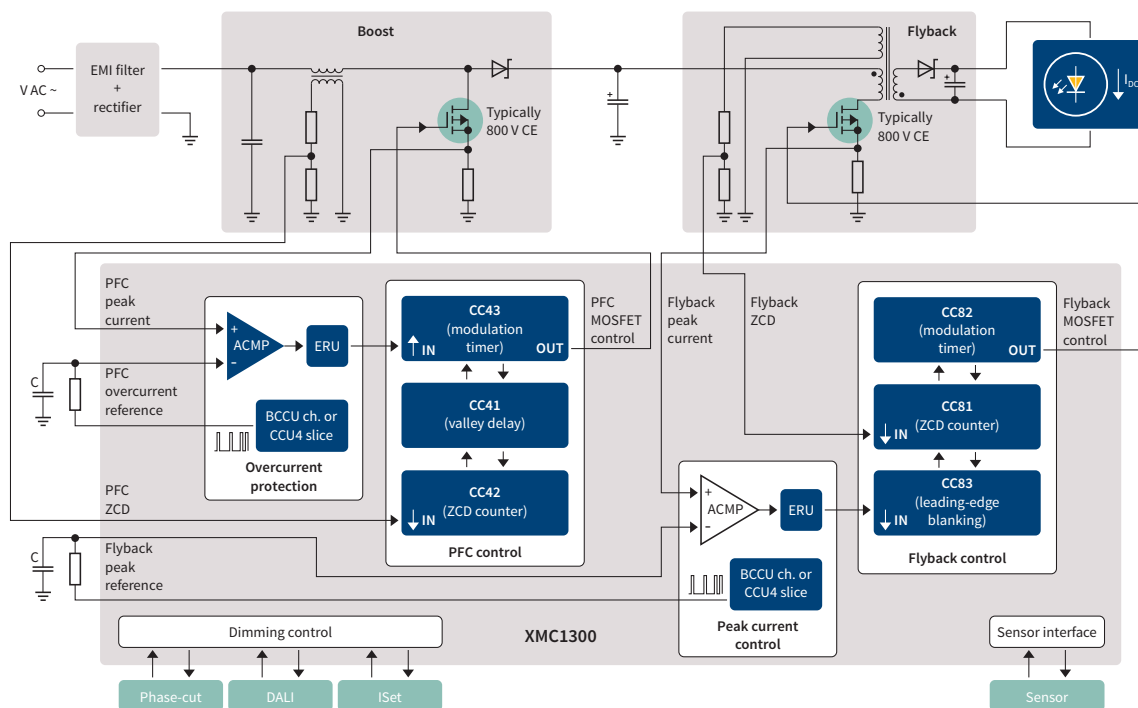



# CoolMOS™ – high-voltage MOSFETs

Trusted leader in high-voltage MOSFETs

The CoolMOS™ power MOSFET family in superjunction technology sets new standards in the field of energy efficiency. Our CoolMOS™ products offer a significant reduction of conduction, switching and driving losses and enable high power density and efficiency for superior power conversion systems. In particular, the latest state-of-the-art

generation of high-voltage power MOSFETs contributes to making LED drivers and LED power supplies more efficient, more compact, lighter and cooler than ever before. Each lighting subapplication has its own requirements and optimization criteria, which are reflected in the available technologies paired with innovative package solutions.

## CoolMOS™ quality – benchmark in short-term and long-term reliability

CoolMOS™ technology is legendary in the semiconductor industry differentiated by high quality and reliability. Our quality has been proven through the years, as demonstrated by the billions of devices shipped with a continuously improving defects per million rate – now down to less than 0.10 DPM. With regard to reliability, the same performance has been proven down to less than 0.15 FIT measured across 130 million device hours. Infineon has implemented

solid and proven measures from the very beginning, such as the design-for-quality program and continuous improvements in production. To achieve these remarkable results, the company promotes constant proactive collaboration between technology, design, quality, reliability and manufacturing teams. These efforts go well beyond the fact that all Infineon sites are ISO/TS 116949-certified.

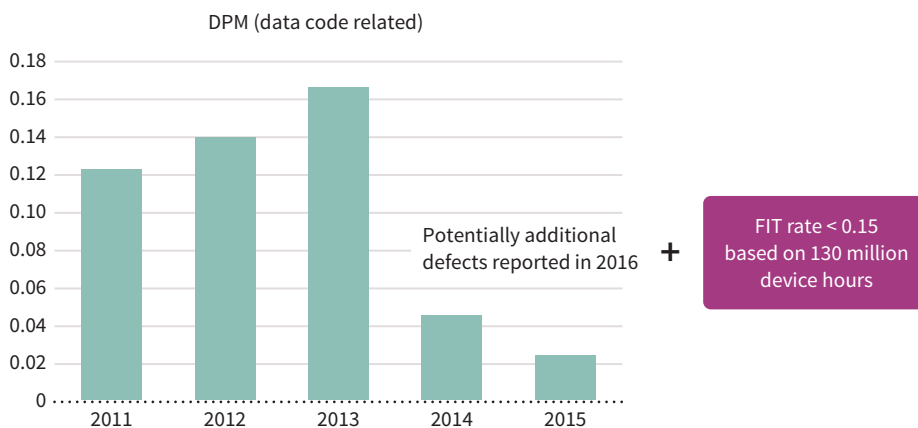

CoolMOS™ comes with a DPM of less than 0.1 and FIT rate of less than 0.15

# CoolMOS™ for lighting applications

Lighting applications create high demands on power supply designs in terms of efficiency, thermal management, surge protection, electromagnetic interference and cost. The most common requirements are addressed with the CoolMOS™ P6 and CE series:

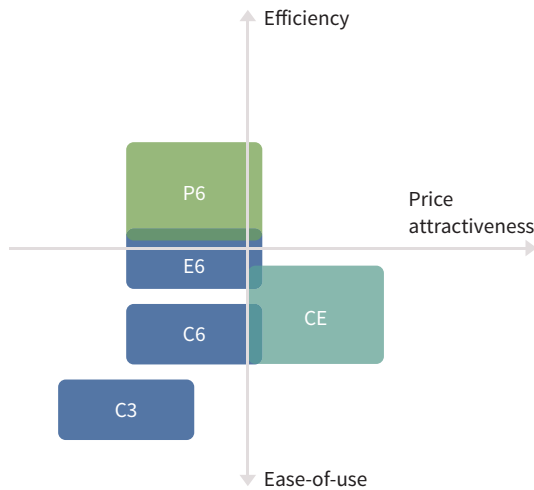

> **CoolMOS™ CE** is a general-purpose series, available in 500 V, 600 V, 650 V, 700 V and 800 V, that is optimized for the best balance between cost, efficiency and ease-of-use. We recommend the CE series as the first choice for cost-sensitive LED lighting applications for diverse topologies.

> **CoolMOS™ P6** is a high-performance series available in 600 V and optimized for high-efficiency PFC and LLC designs in the mid to high power range. The P6 family is perfectly suited for outdoor and high bay lighting, along with office lighting where PFC and LLC topology is used.

> **CoolMOS™ C3** is primarily recommended for 900 V designs and for selected 800 V designs with high requirements in relation to reliability and ruggedness. Other parts of the C3 series, e.g. 500 V, 600 V and 650 V, will continue to be produced for an extended period of time, offering excellent ruggedness, ease-of-use and a low EMI. However, these parts have since been surpassed by newer generations in terms of efficiency and product cost.

> **CoolMOS™ C6/E6** is a general-purpose series that can be used in LED lighting in the unlikely event that the above-mentioned series do not fit or the desired part is not available in the portfolio.

## Commercial LED lighting ballast

Flyback topology

Buck topology

LLC topology

PFC

## Standard line with focus on: price/performance

> CE 800 V/(900 V)  
– 0.31 to 2.8 Ω

> CE 500/600 V  
– 0.19 to 2.1 Ω

> CE 500/600 V  
– 0.19 to 2.1 Ω

> CE 600 V  
650/500 V  
– 0.19 to 1.0 Ω

## Enhanced line with focus on: performance

> C3 800 V/900 V  
– 0.31 to 2.8 Ω

> P6 600 V  
– 0.041 to 0.6 Ω  
– Individual design  
vs standard line

> P6 600 V  
– 0.041 to 0.6 Ω  
– High power  
– Individual design  
vs standard line

> P6 600 V  
– 0.041 to 0.6 Ω  
– Higher power

# CoolMOS™ CE – focus on efficiency, cost-effectiveness and part availability

Good efficiency, ease-of-use and EMI performance at an attractive cost position make the CoolMOS™ CE series the product of choice for LED drivers or LED tubes in buck, flyback, PFC and LLC topology. Its benefits include an improvement in efficiency and thermal behavior compared to standard MOSFETs.

CoolMOS™ products aimed at lighting bring the benefits of highest quality and delivery reliability as outlined in the overview section for the CoolMOS™ portfolio. However, the CoolMOS™ CE series has been defined with a particular focus on the customers' needs, for an attractive price and fastest supply availability: at any given time and for any product of the CoolMOS™ CE series, orders of up to 30 k units can be shipped from our distribution center within 5 days.

## Further reasons to choose CoolMOS™ CE

Non-technical benefits provided by CoolMOS™	CE
Product portfolio	We own a broad portfolio covering five voltage classes in both through-hole and SMD packages.
Capacity	We own the world's largest capacity for power devices, with three dedicated frontends and four backends. Thanks to factors such as the continued investment in our production facilities, we ensure a secure supply during a market upswing.
Lead time	We understand consumer and lighting market dynamics and offer a lead time as short as 5 days.
Delivery performance	Our supply chain performance is constantly greater than or equal to 96 percent (adhering to the customer committed date).
Quality	Our field failure rates are as low as 0.1 PPM.
Design-in support	We have a large field application engineering team dedicated to providing professional and flexible support for your design.

## CoolMOS™ CE in an SOT-223 package

With the rapid conversion from CFL to LED lighting, customer requirements are rapidly changing: on the one hand, power levels are further decreasing, while on the other hand, increasing cost pressure compels power designers to optimize designs to a fraction of a cent. The completion

of the CoolMOS™ CE portfolio with the SOT-223 package is Infineon's answer to this challenge: it facilitates a further reduction in BOM cost – and additional footprint optimization in some designs – with only a minor compromise in terms of thermal behavior.

### SOT-223 as drop-in replacement for DPAK at a lower cost

The SOT-223 package with a decapped middle pin is fully compatible with the footprint of a DPAK, therefore allowing one-on-one drop-in replacements and second sourcing.

## SOT-223 as drop-in replacement for DPAK at a lower cost

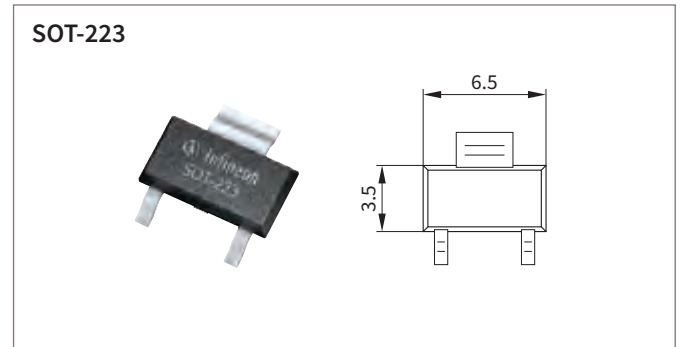
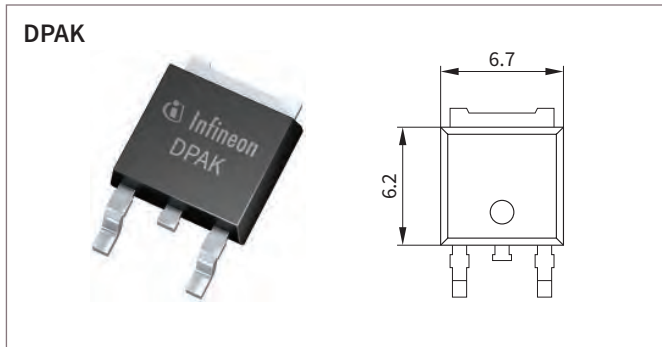

### Thermal behavior – on a par with DPAK

The thermal behavior of the SOT-223 primarily depends on the layout of the board where the package is used and on the power consumed. We have measured the thermals in

a test environment and compared them with a simulation. Compared to a DPAK positioned on a typical DPAK footprint, the SOT-223 displays the following thermal behavior:

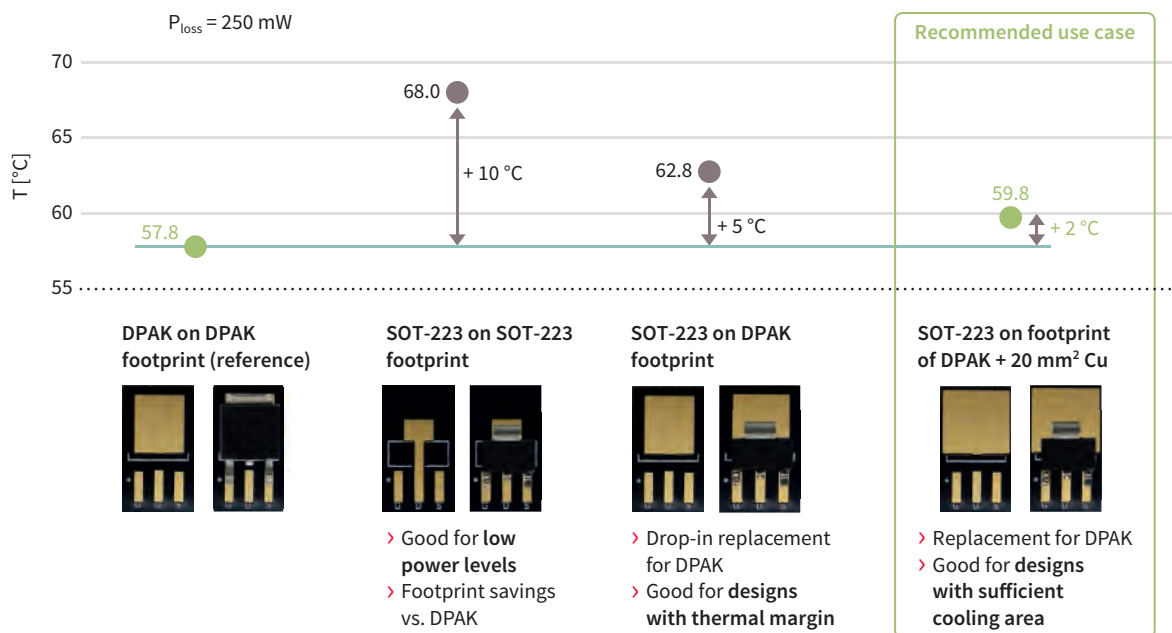

- > **Same footprint as DPAK** – when mounted on a standard DPAK footprint, the SOT-223 package shows a temperature elevated by 4–5 K. This behavior makes the SOT-223 suitable for designs with a thermal margin
- > **Footprint of DPAK plus ~20 mm<sup>2</sup> additional copper area** – in many designs, the MOSFET is mounted on a larger Cu area which serves as a heatsink embedded in the PCB. As soon as 20 mm<sup>2</sup> Cu or more is available in addition to

the DPAK footprint, the temperature increase is no more than 2–3 K above DPAK and the SOT-223 can be used as a drop-in replacement

- > **SOT-223 on SOT-223 footprint** – when mounted on the SOT-223 footprint without an additional surrounding Cu area, the package leads to a 10 °C temperature increase compared to a DPAK. This means that the option of space savings via the SOT-223 is only useful for very low power applications

## Thermal behavior – on a par with DPAK

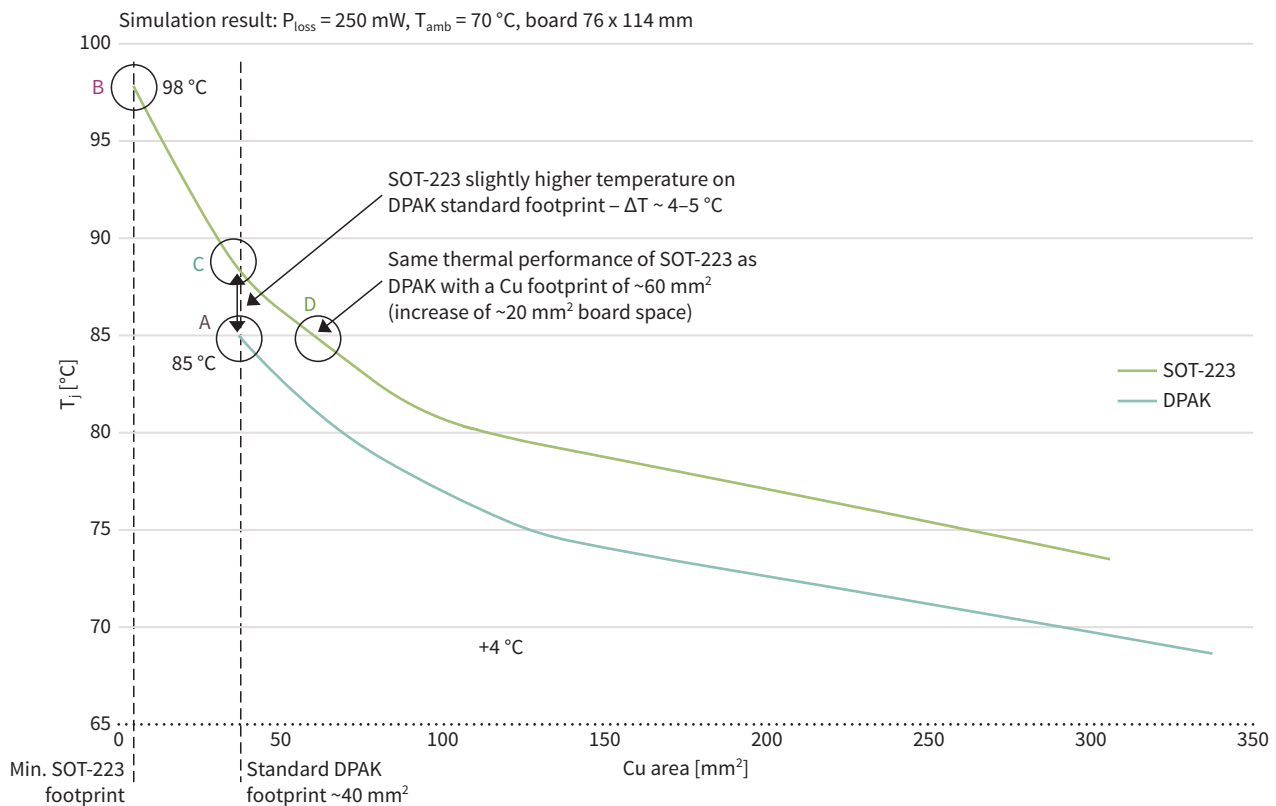

The laboratory findings on thermal behavior are confirmed by a thermal simulation with  $T_{\text{ambient}} = 70 \text{ }^\circ\text{C}$  and  $P_{\text{loss}} = 250 \text{ mW}$ . The size of the copper area in the footprint is shown on the x-axis, while the y-axis displays the temperature of the package top side. In the case of an SOT-223

on DPAK footprint, the 4–5 K temperature increase over DPAK is confirmed. But when used in conjunction with an enlarged copper area of  $\sim 20 \text{ mm}^2$ , a temperature increase of 2–3 K is measured.

## CoolMOS™ CE SOT-223 product portfolio

$R_{\text{DS(ON)}} [\text{m}\Omega]$	500 V	600 V	650 V	700 V
3400		IPN60R3K4CE		
3000	IPN50R3K0CE			
2000/2100	IPN50R2K0CE	IPN60R2K1CE		
1400/1500	IPN50R1K4CE	IPN60R1K5CE	IPN65R1K5CE	IPN70R1K5CE
950/1000	IPN50R950CE	IPN60R1K0CE		
800	IPN50R800CE			
650	IPN50R650CE			

# 600 V CoolMOS™ P6 series

Superior efficiency combined with ease-of-use

600 V CoolMOS™ P6 is a high-performance part suitable for high-power lighting applications which require excellent performance, yet also a high level of ease-of-use in the design-in process. CoolMOS™ P6 is suitable for both soft- and hard-switching applications due to its great body diode

ruggedness. CoolMOS™ P6 achieves very low conduction and switching losses especially in light-load conditions, enabling switching applications to work more efficiently and be designed in a more compact manner.

CoolMOS™ P6 is optimized for ease-of-use and addresses typical design challenges

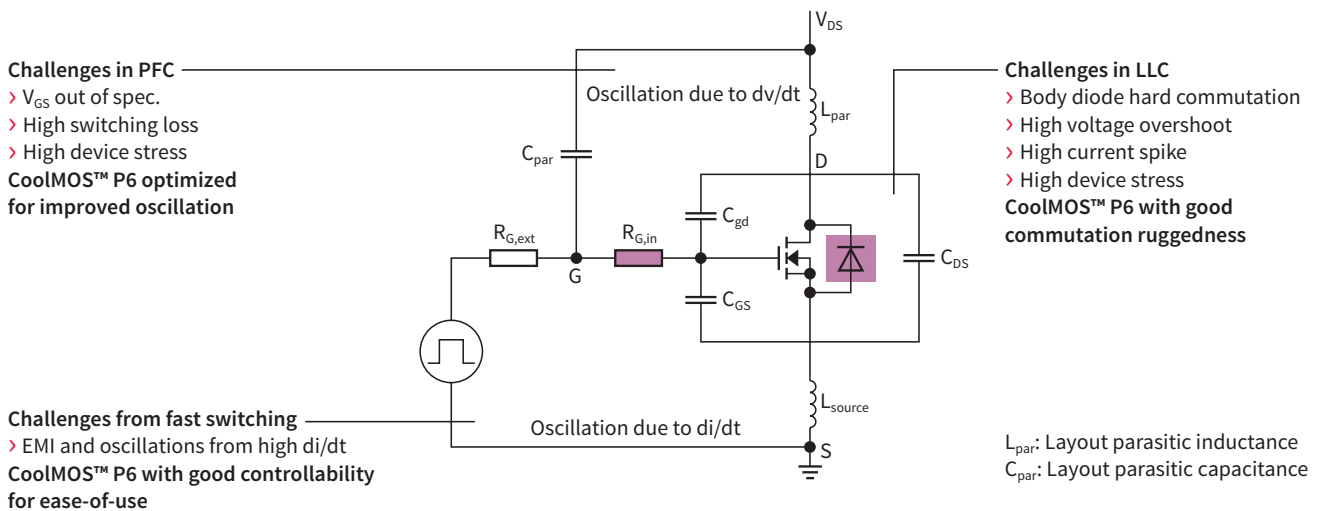

LLC – CoolMOS™ P6 with best-in-class performance

Efficiency comparison of 190 mΩ device tested on Infineon 600 W LLC board

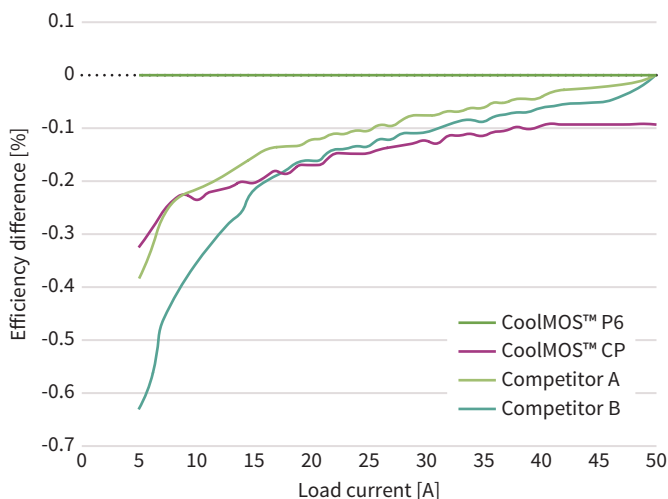

CoolMOS™ P6 displays the best-in-class efficiency over the entire load range – especially under light-load conditions – thanks to its low  $Q_G$  and higher  $V_{th}$ . Main competitor products are at a level below CoolMOS™ P6 or lower than CoolMOS™ C6.

CoolMOS™ P6 sets the benchmark in LLC efficiency

- > Low  $Q_G$  improves the light-load efficiency
- > Higher  $V_{th}$  improves efficiency due to lower turn-off losses

# CoolMOS™ supply chain – delivery reliability, flexibility and supply security

Our customers value CoolMOS™ not only for its technical merits but also for the outstanding delivery reliability: once a CoolMOS™ order date is committed, over 96 percent of orders are shipped on or before the actual committed date. In addition over 80 percent of CoolMOS™ orders are committed to the date the customer requests. Security of supply and the flexibility to react to demand fluctuations

are objectives enabled by a well-balanced production network. Over 90 percent of our products, for example, are qualified for production in at least two backend locations and more than 80 percent of the volumes in two wafer fabs. This enables the CoolMOS™ supply chain to quickly react to changes in customer and market requirements.

## Delivery reliability: ship date = committed date

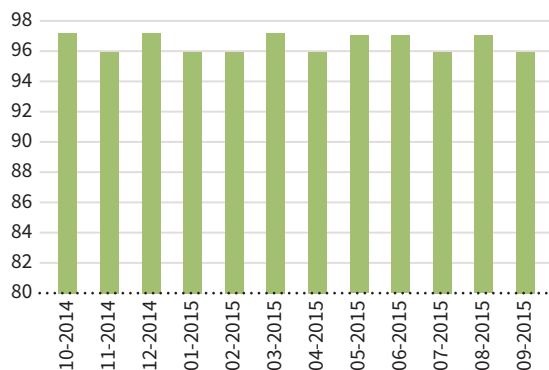

## Delivery capability: confirm customers' wish date

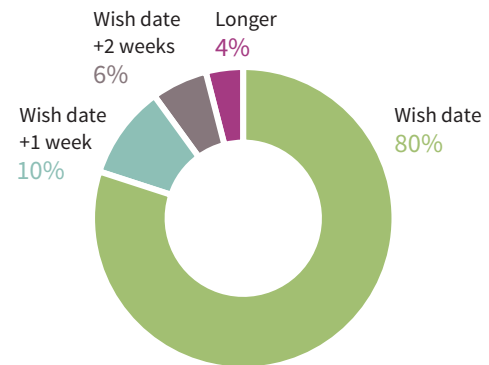

≥ 96% of CoolMOS™ orders are shipped by the committed date and ≥ 80% of wish dates can be met

## 600 V CoolMOS™ P6

$I_D$ [A]	$R_{DS(on)}$ [mΩ]	TO220	TO263 (D <sup>2</sup> PAK)	TO220 FullPAK	TO247	TO247 4 pin	TO252 (DPAK)	ThinPAK 5 x 6	ThinPAK 8 x 8
	41				IPW60R041P6	IPZ60R041P6 <sup>1)</sup>			
53.5	70				IPW60R070P6	IPZ60R070P6 <sup>1)</sup>			
37.9	99	IPP60R099P6		IPA60R099P6	IPW60R099P6	IPZ60R099P6 <sup>1)</sup>			
30	125	IPP60R125P6		IPA60R125P6	IPW60R125P6	IPZ60R125P6 <sup>1)</sup>			
10.4–23.8	160	IPP60R160P6	IPB60R160P6 <sup>1)</sup>	IPA60R160P6	IPW60R160P6				
	180								IPL60R180P6
9.5–20.2	190	IPP60R190P6	IPB60R190P6 <sup>1)</sup>	IPA60R190P6	IPW60R190P6				
19.2	210								IPL60R210P6
8.6–16.8	230	IPP60R230P6	IPB60R230P6 <sup>1)</sup>	IPA60R230P6	IPW60R230P6				
15.9	255								IPL60R255P6
7.7–13.8	280	IPP60R280P6	IPB60R280P6 <sup>1)</sup>	IPA60R280P6	IPW60R280P6				
7.0–12.0	330/360	IPP60R330P6	IPB60R330P6 <sup>1)</sup>	IPA60R330P6	IPW60R330P6				IPL60R360P6S
6.5–10.6	380	IPP60R380P6	IPB60R380P6 <sup>1)</sup>	IPA60R380P6			IPD60R380P6		
4.9–7.3	600	IPP60R600P6	IPB60R600P6 <sup>1)</sup>	IPA60R600P6			IPD60R600P6		
6.7	650								IPL60R650P6S

1) Coming soon

## 500 V CoolMOS™ CE

$I_D$ [A]	$R_{DS(on)}$ [mΩ]	TO220	TO220 FullPAK	TO247	TO252 (DPAK)	TO251 (IPAK)	TO251 (IPAK SL)	SOT-223
18.5	190	IPP50R190CE	IPA50R190CE	IPW50R190CE				
7.5–13.0	280	IPP50R280CE	IPA50R280CE	IPW50R280CE	IPD50R280CE			
6.3–9.9	380	IPP50R380CE	IPA50R380CE		IPD50R380CE			
5.4–7.6	500	IPP50R500CE	IPA50R500CE		IPD50R500CE			
4.6–6.1	650		IPA50R650CE		IPD50R650CE			IPN50R650CE
4.1–5.0	800		IPA50R800CE		IPD50R800CE			IPN50R800CE
3.7–4.3	950		IPA50R950CE		IPD50R950CE	IPU50R950CE		IPN50R950CE
3.1	1400				IPD50R1K4CE	IPU50R1K4CE		IPN50R1K4CE
2.4	2000				IPD50R2K0CE	IPU50R2K0CE		IPN50R2K0CE
1.5	3000				IPD50R3K0CE	IPU50R3K0CE		IPN50R3K0CE

## 600 V CoolMOS™ CE

$I_D$ [A]	$R_{DS(on)}$ [mΩ]	TO220 FullPAK	TO220 FullPAK wide creepage	TO252 (DPAK)	TO251 (IPAK)	TO251 (IPAK SL)	SOT-223
	190		IPAW60R190CE				
	280		IPAW60R280CE				
	380		IPAW60R380CE				
10.3	400	IPA60R400CE		IPD60R400CE		IPS60R400CE	
9.1	460	IPA60R460CE		IPD60R460CE		IPS60R460CE	
	600		IPAW60R600CE				
7.0	650	IPA60R650CE		IPD60R650CE		IPS60R650CE	
5.6	800	IPA60R800CE		IPD60R800CE		IPS60R800CE	
4.3	1000	IPA60R1K0CE		IPD60R1K0CE	IPU60R1K0CE	IPS60R1K0CE	IPN60R1K0CE
3.1	1500	IPA60R1K5CE		IPD60R1K5CE	IPU60R1K5CE	IPS60R1K5CE	IPN60R1K5CE
2.3	2100			IPD60R2K1CE	IPU60R2K1CE	IPS60R2K1CE	IPN60R2K1CE
	3400			IPD60R3K4CE	IPU60R3K4CE	IPS60R3K4CE	IPN60R3K4CE

## 650 V CoolMOS™ CE

$I_D$ [A]	$R_{DS(on)}$ [mΩ]	TO220 FullPAK	TO252 (DPAK)	TO251 (IPAK SL)	SOT-223	ThinPAK 5 x 6
	400	IPA65R400CE	IPD65R400CE	IPS65R400CE		
	650	IPA65R650CE	IPD65R650CE	IPS65R650CE		
4.3	1000	IPA65R1K0CE	IPD65R1K0CE	IPS65R1K0CE		
3.1	1500	IPA65R1K5CE	IPD65R1K4CE	IPS65R1K5CE	IPN65R1K5CE	

## 700 V CoolMOS™ CE

$I_D$ [A]	$R_{DS(on)}$ [mΩ]	TO262 (I <sup>2</sup> PAK)	TO252 (DPAK)	TO251 (IPAK SL)	SOT-223	ThinPAK 5 x 6
	600		IPD70R600CE	IPS70R600CE		
	950	IP170R950CE	IPD70R950CE	IPS70R950CE		
3.2	1400		IPD70R1K4CE	IPS70R1K4CE		
	1500				IPN70R1K5CE	
	2000		IPD70R2K0CE	IPS70R2K0CE		
	2100					IPL70R2K1CES

## 800 V CoolMOS™ CE

$I_D$ [A]	$R_{DS(on)}$ [mΩ]	TO220	TO220 FullPAK	TO247	TO252 (DPAK)	TO251 (IPAK)	TO251 (IPAK SL)
6.8	310		IPA80R310CE				
5.0	460		IPA80R460CE				
4.5	650		IPA80R650CE				
3.6–5.7	1000		IPA80R1K0CE		IPD80R1K0CE	IPU80R1K0CE	
2.8–3.9	1400		IPA80R1K4CE		IPD80R1K4CE	IPU80R1K4CE	
1.9	2800				IPD80R2K8CE	IPU80R2K8CE	

# OptiMOS™ – medium-voltage MOSFETs

## OptiMOS™ portfolio for LED drivers

Low- and medium-voltage MOSFETs are mainly used as a power stage in combination with an LED controller or microcontrollers. We offer a wide portfolio of OptiMOS™ from 100 V to 250 V. OptiMOS™ consistently sets the

benchmark in key specifications for power system design including ON-state resistance, leading to reduced power losses and improved overall efficiency.

### Typical application diagram

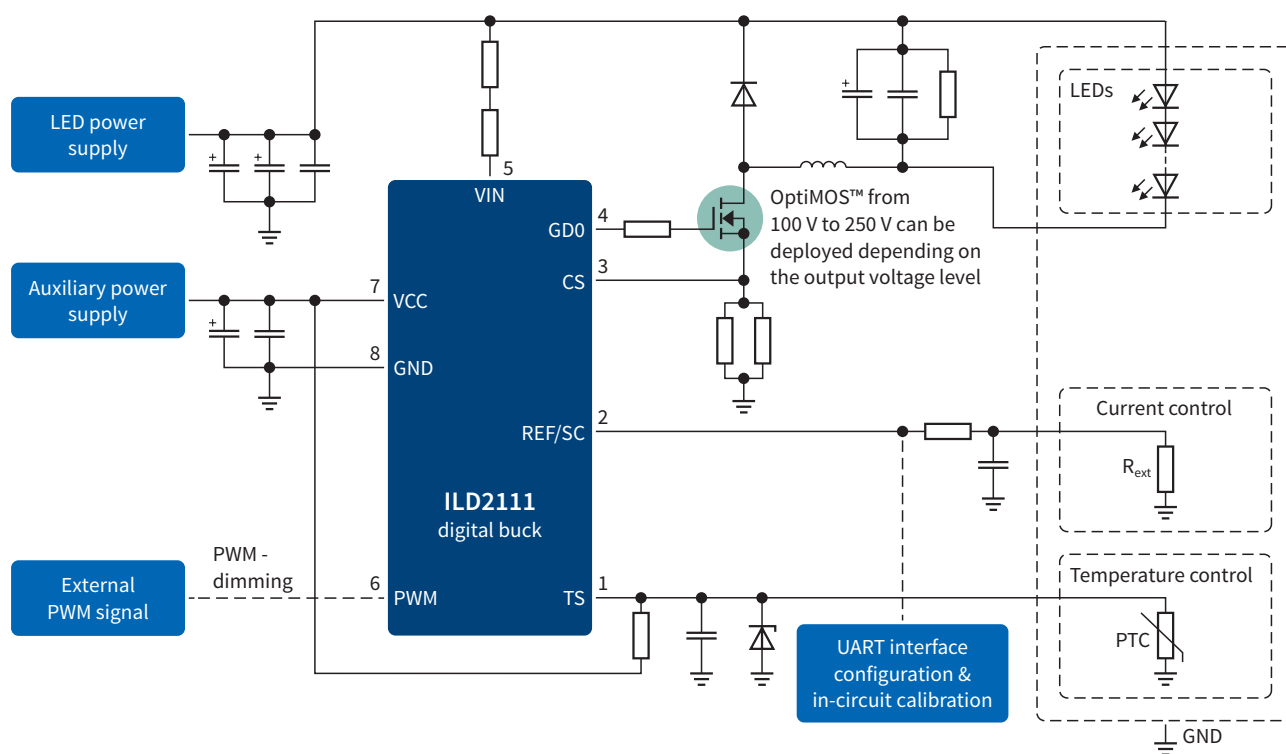

**OptiMOS™ 100 V normal level**

$R_{DS(on)}$ max @ $V_{GS} = 10\text{ V}$ [mΩ]	TO252 (DPAK)	SuperSO8	SOT-223
12–18	IPD122N10N3 G $R_{DS(on)} = 12.2\text{ m}\Omega$	BSC160N10NS3 G $R_{DS(on)} = 16.0\text{ m}\Omega$	
2x 75		BSC750N10ND G $R_{DS(on)} = 75.0\text{ m}\Omega$	

**OptiMOS™ 150 V normal level**

$R_{DS(on)}$ max @ $V_{GS} = 10\text{ V}$ [mΩ]	TO252 (DPAK)	SuperSO8	SOT-223
16–30	IPD200N15N3 G $R_{DS(on)} = 20.0\text{ m}\Omega$	BSC190N15NS3 G $R_{DS(on)} = 19.0\text{ m}\Omega$	
30–60	IPD530N15N3 G $R_{DS(on)} = 53.0\text{ m}\Omega$	BSC360N15NS3 G $R_{DS(on)} = 36.0\text{ m}\Omega$	
		BSC520N15NS3 G $R_{DS(on)} = 52.0\text{ m}\Omega$	

**OptiMOS™ 200 V normal level**

$R_{DS(on)}$ max @ $V_{GS} = 10\text{ V}$ [mΩ]	TO252 (DPAK)	SuperSO8	SOT-223
30–40	IPD320N20N3 G $R_{DS(on)} = 32.0\text{ m}\Omega$	BSC320N20NS3 G $R_{DS(on)} = 32.0\text{ m}\Omega$	
40–50		BSC500N20NS3 G $R_{DS(on)} = 50.0\text{ m}\Omega$	
80–100		BSC900N20NS3 G $R_{DS(on)} = 90.0\text{ m}\Omega$	
100–200		BSC12DN20NS3 G $R_{DS(on)} = 125.0\text{ m}\Omega$	
200–300		BSC22DN20NS3 G $R_{DS(on)} = 225.0\text{ m}\Omega$	

**OptiMOS™ 250 V normal level**

$R_{DS(on)}$ max @ $V_{GS} = 10\text{ V}$ [mΩ]	TO252 (DPAK)	SuperSO8	SOT-223
60–70	IPD600N25N3 G $R_{DS(on)} = 60.0\text{ m}\Omega$	BSC600N25NS3 G $R_{DS(on)} = 60.0\text{ m}\Omega$	
100–200		BSC16DN25NS3 G $R_{DS(on)} = 165.0\text{ m}\Omega$	

**OptiMOS™ 100 V logic level**

$R_{DS(on)}$ max @ $V_{GS} = 10\text{ V}$ [mΩ]	TO252 (DPAK)	SuperSO8	SOT-223
12–18		BSC123N10LS G $R_{DS(on)} = 12.3\text{ m}\Omega$	
		BSC123N10LS G $R_{DS(on)} = 12.3\text{ m}\Omega$	
20–40		BSC265N10LSF G $R_{DS(on)} = 26.5\text{ m}\Omega$	

**OptiMOS™ small signal 100 V**

$R_{DS(on)}$ max @ $V_{GS} = 10\text{ V}$ [mΩ]	TO252 (DPAK)	SuperSO8	SOT-223
23–27			BSP372N $R_{DS(on)} = 230\text{ m}\Omega$

**OptiMOS™ small signal 200 V**

$R_{DS(on)}$ max @ $V_{GS} = 10\text{ V}$ [mΩ]	TO252 (DPAK)	SuperSO8	SOT-223
1000–1800			BSP297 $R_{DS(on)} = 1800\text{ m}\Omega$

**OptiMOS™ small signal 240 V**

$R_{DS(on)}$ max @ $V_{GS} = 10\text{ V}$ [mΩ]	TO252 (DPAK)	SuperSO8	SOT-223
4200–6000			BSP89 $R_{DS(on)} = 6000\text{ m}\Omega$



# Light management

There are various fields where light management, also known as smart lighting, can be of benefit to people due to:

- › Realizing further energy savings via the implementation of presence detectors and/or ambient light detectors
- › Adapting light levels and light color in accordance with the needs of users – human-centric light
- › Automation for enabling more comfortable use, such as predefined settings
- › Diagnosis functions to enable easier maintenance
- › Maintaining lumen levels over lifetime

LED lighting offers new smart lighting opportunities. This is due to the fact that LEDs are the first light sources that actually extend their lifetime when they are switched on/off frequently. Furthermore, compared to other light sources they generate higher energy savings when dimmed. Yet another benefit is that electronics is an integral part of LED luminaires and can be easily connected to lighting control systems.

Smart lighting features can be implemented in decentralized or centralized control systems. When used with centralized control systems, different wired or wireless communication systems are used.

Microcontrollers & sensors are key components for enabling smart lighting.

Main functions of microcontrollers in smart lighting:

- › Enable connectivity to bus systems such as DALI, DMX, KNX etc.
- › Enable connectivity to sensors
- › Enable the programming of intelligent light features as required by the end user

Main functions of sensors in lighting:

- › Detect presence
- › Detect the ambient light level

# Microcontrollers for LED lighting

## XMC1000 family

The XMC1000 product family integrates the ARM® Cortex®-M0 core into a leading-edge 65 nm manufacturing process in order to overcome the limitations of contemporary 8-bit designs. The XMC1000 offers current 8-bit users a new opportunity to enjoy 32-bit power, without having to compromise on price or ease-of-use. Four product series cover a range of application fields.



- › The XMC1100 series is not only designed for easy entry into the XMC™ world, but is also cost- and size-optimized for use as a pure communication IC in LED lighting applications
- › The XMC1200 line features dedicated peripherals for LED lighting designs
- › The XMC1300 series addresses real-time control requirements in many fields, such as digital power conversion applications
- › The XMC1400 is the highest performance series within the XMC1000 family. Adding bigger packages makes it best suitable for advanced , multichannel lighting control (e.g. RGBW intelligent lighting control) and DC/DC power conversion

DAVE™ is a complete free development environment for XMC™ microcontrollers. It features a complete SW development tool-chain and DAVE™ Apps for reducing SW complexity and time-to-market.

Product series	System			Timers			Signal processing		Communication	Application specific		
	Co-processor	Flash memory [KB]	RAM [KB]	CCU4 (4 ch, 16-bit)	CCU8 (8 ch, 16-bit)	POSIF (hall & encoder I/F)	ADC (12-bit)	AnaComp	USIC (2 ch, UART, SPI, I <sup>2</sup> C, I <sup>2</sup> S), CAN	LED brightness & color control	LED display control	Touch control
XMC1100	–	8–64	16	1	–	–	1x	–	1x USIC	–	–	–
XMC1200	–	16–200	16	1	–	–	2x	up to 3	1x USIC	9 ch	64 segment	16 buttons
XMC1300	MATH (CORDIC/DIV)	8–200	16	1	1	1x	2x	3x	1x USIC	9 ch	–	–
XMC1400	MATH (CORDIC/DIV)	32–200	16	2	2	1	2x	4x	2x USIC, CAN	9 ch	–	–

### Key features & benefits of the XMC1000 family

- › Low-cost 32-bit MCU with a programmable memory of up to 200 KB flash
- › Connectivity (UART, SPI, I<sup>2</sup>C, I<sup>2</sup>S) to external motion or light sensors and a DALI or DMX lighting bus (for example)
- › Free DAVE™ App with DALI stack
- › Specific easy-to-use peripherals for flicker-free LED-dimming, automated calibration to various drivers and smooth color mixing
- › Fast ADC (< 0.5 μs) and peripheral interconnects for precise real-time control loops

# Available XMC™ lighting evaluation kits

## LED lighting application kit



Color LED card

Modular kit consisting of a XMC1200 boot kit and 2 LED cards. Software examples and supporting DAVE™ APPs are available for this kit

### Color LED card

- > 3 RGB LEDs, 10 mA
- > Each channel is driven by a BCR421 linear LED driver and modulated by a PDM output
- > Connectivity: DALI, DMX512, RF
- > Ambient light sensor



White LED card

### White LED card

- > 20 LEDs in 4 strings, 20 mA
- > Connectivity: DALI, RF
- > Ambient light sensor
- > Temperature sensor
- > Linear LED drivers

## RGB LED lighting shield for Arduino

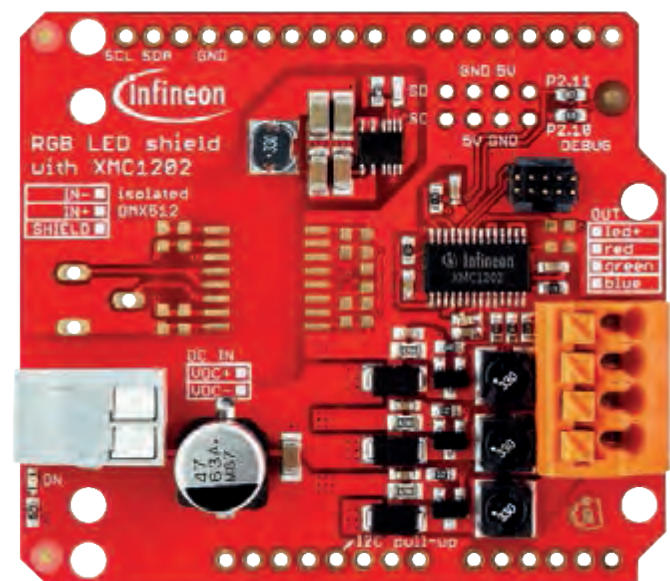

Shield can be used with an Arduino (Genuino) Uno R3 board or with the XMC1100 boot kit

### Features

- > 3 independent DC/DC buck channels
- > XMC1202 microcontroller with 16 K flash
- > Up to 48 V DC input
- > Up to 700 mA output on each channel
- > Connectivity: I<sup>2</sup>C, isolated DMX512 (not mounted)
- > Software examples and DAVE™ APPs available

## XMC™ LED current control explorer

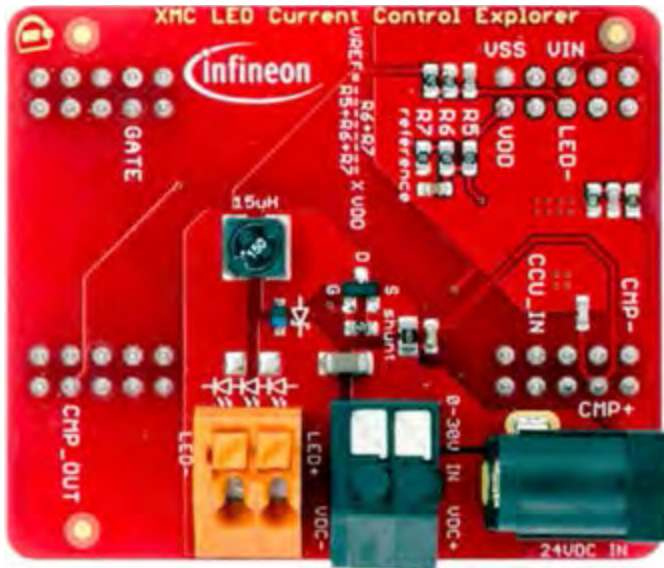

LED driver board



Isolated DALI interface board

Modular kit consisting of a XMC1300 boot kit, single-channel LED driver and Isolated DALI interface plug-on board.

### Features

- > Single-channel, high-speed dimmable DC/DC buck LED driver
- > Up to 30 V DC input voltage
- > Up to 700 mA average output current
- > Up to 1 A peak current
- > Isolated DALI interface
- > Programmable current ripple
- > DALI stack example

## Superior flicker and color control thanks to the Brightness & Color Control Unit (BCCU)

Thanks to their Brightness and Color Control Unit (BCCU), XMC1000 products offer a unique module for automatically controlling the dimming level and color of multichannel LED lamps. Users can quickly configure their ideal solution without the need for an expert knowledge of lighting.

Furthermore, XMC1000 products can also be used as DALI or DMX512 slaves and therefore comply with standard lighting communication protocols. DAVE™ Apps are available for both standards.

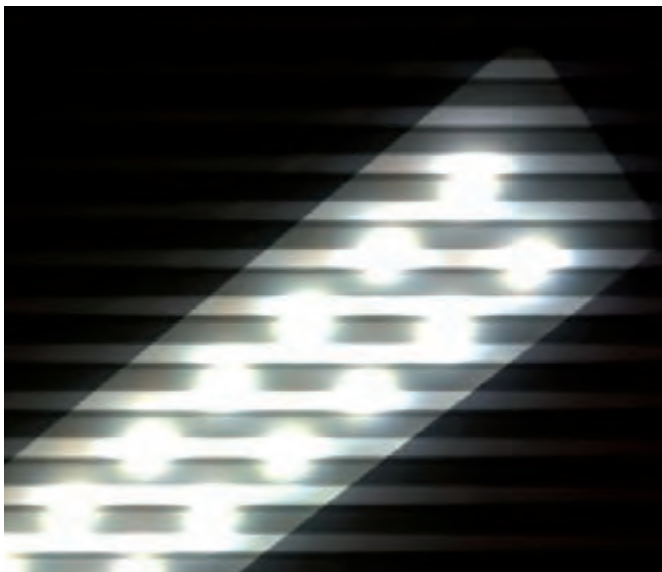

2 kHz flicker with a commercial stand-alone ballast – annoying lines are visible when filmed with an HD camera.



Infineon solution with XMC1000. Flickering (40–50 kHz) is neither visible nor detectable by HD cameras.

### Key features of the Brightness and Color Control Unit (BCCU)

- › Automatic high-frequency brightness modulation based on the  $\Sigma\Delta$  principle enables completely flicker-free dimming on up to 9 output channels
- › Automatic exponential dimming and linear intensity changes make brightness or color changes appear smooth and natural to the human eye
- › An integrated packer function ensures controlled switching rates for a wide range of high-power LED drivers
- › BCCU, CCU4 and the on-chip analog comparators are interconnected via the ERU connection matrix for highly efficient dimmable peak-current control setups

# DAVE™ teams up with the well-established ARM® ecosystem

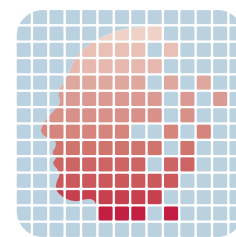

With DAVE™, software developers can generate a tailored software library to efficiently use the innovative set of peripherals of the XMCT™ microcontrollers. DAVE™ is a free and complete development platform based on Eclipse CDT including the ARM® GNU compiler, a free debugger with flash loader and the data visualization tool xSPY.

The generated code can be also used in third-party tools such as Atollic, IAR, Keil MDK, Rowley and TASKING.

DAVE™ comes with an extensive and powerful library of applications – DAVE™ Apps, which are object-oriented software building blocks. A DAVE™ App represents an application use case such as the generation of a PWM signal, measurement of analog signals or various types of data communication. Even middleware components such as communication stacks, file systems or specific target applications like motor control or lighting are available as DAVE™ Apps.

<p><b>Service Apps</b></p> <ul style="list-style-type: none"> <li>&gt; Clock, reset</li> <li>&gt; Power mgmt.</li> <li>&gt; Watchdog</li> <li>&gt; DMA</li> <li>&gt; NVIC/exception</li> <li>&gt; I/O, EBU, flash</li> <li>&gt; Debug log</li> <li>&gt; ...</li> </ul>	<p><b>Standard middleware Apps</b></p> <ul style="list-style-type: none"> <li>&gt; USB stack, and drivers</li> <li>&gt; TCP/IP stack</li> <li>&gt; SD/MMC, file system</li> <li>&gt; GUI lib plus LCD driver</li> <li>&gt; RTOS</li> </ul>
<p><b>Specific middleware Apps</b></p> <ul style="list-style-type: none"> <li>&gt; Motor control</li> <li>&gt; Lighting</li> <li>&gt; Power conversion</li> <li>&gt; HMI</li> </ul>	<p><b>Peripheral Apps</b></p> <ul style="list-style-type: none"> <li>&gt; PWM, capture, timer, counter</li> <li>&gt; UART, SPI, I<sup>2</sup>C CAN, ...</li> <li>&gt; ADC, DAC, ...</li> <li>&gt; POSIF, ...</li> </ul>

Select a DAVE™ App from a large library of more than 170 Apps

For more information and free downloads, visit [www.infineon.com/dave](http://www.infineon.com/dave)

[www.infineon.com/dave](http://www.infineon.com/dave)

A major innovation highlight of DAVE™ is the resource solver. While the user selects and configures the DAVE™ Apps on a logical level, the resource solver ensures that the necessary chip resources are properly assigned and mapped. Resource mapping can be done fully automatically by the solver which takes into consideration the required inter-chip connectivity and user-defined constraints such as manually assigned pins.



Configure the DAVE™ App using a graphical user interface

The code generated based on the selected and configured DAVE™ Apps is in fact a software library which is accessible as a fully documented and human-readable source code that provides all the functions (APIs) required to build the final application. With DAVE™, software developers are free to concentrate on differentiating their IP, leaving the time-consuming, low-level and middleware work to DAVE™ Apps.

```
int main(void)
{
    //Initialization of the HW used by DAVE
    DAVE_Init();
    // Send data via UART channel defined in hand
    UART001_WriteData(UART001_Handle0,data);
    // Read data via UART channel defined in hand
    Readdata = UART001_ReadData(UART001_Handle0);
}
```

Complete your application using the APIs or macros from the generated library.

# Radar sensors

## 24GHz radar demonstrator kit for presence detection

A lot of energy is currently wasted due to illuminated areas where nobody is present. Passive Infrared (PIR) is a simple way of detecting presence. However, passive infrared sensors are not suitable for presence detection

- > In big areas such as warehouses, factories etc.
- > In outdoor weather conditions (rain, fog, snow...)
- > For radial movements

Compared to infrared, radar solutions from Infineon can cover areas about 10 times larger.

A further key advantage of microwave 24GHz radar solutions for presence detection is their fine resolution in detecting and discriminating the motion of small objects, along with the direction and speed of objects. Microwave radar precision also enables the location of individuals to be determined.

Infineon offers a 24GHz radar demonstrator kit based on the radar transceiver BGT24MTR11 in combination with the microcontroller XMC4200, along with a second kit using BGT24MTR12 together with the microcontroller XMC4400 developed by System Design House partners.

The radar sensor solution based on the BGT24Mxx 24GHz ISM band radar transceiver family saves around 30% board space compared to discrete line-ups. This is due to the fact that it offers the highest level of integration currently available on the market.

In addition to conserving board space, the high integration of the Infineon solution – where the transmit and receive channels are on a single chip – makes the design easy as no 24GHz RF matching/RF transmission lines are required.

Infineon offers three different components – the BGT24MTR11 which combines one transmit and one receive channel, the BGT24MTR12 which comprises one transmit and two receive channels, and the BGT24MR2, a chip with two receive channels, combinable with both chipsets. A new BGT24LTR11 (1Tx and 1Rx) is scheduled for release in summer 2016, which provides a smaller package and lower power consumption compared to existing BGT-24Mxxx products.

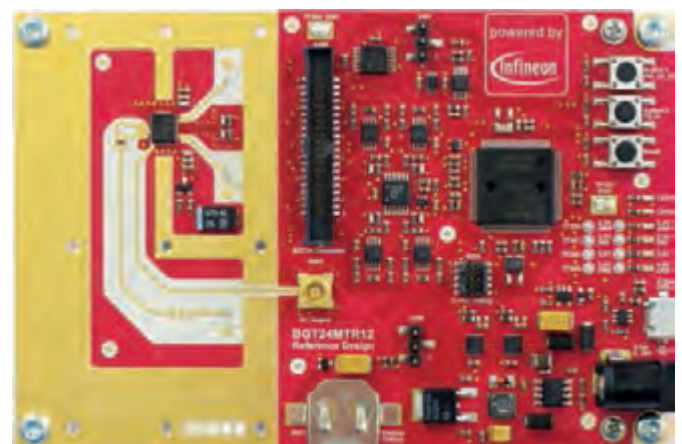
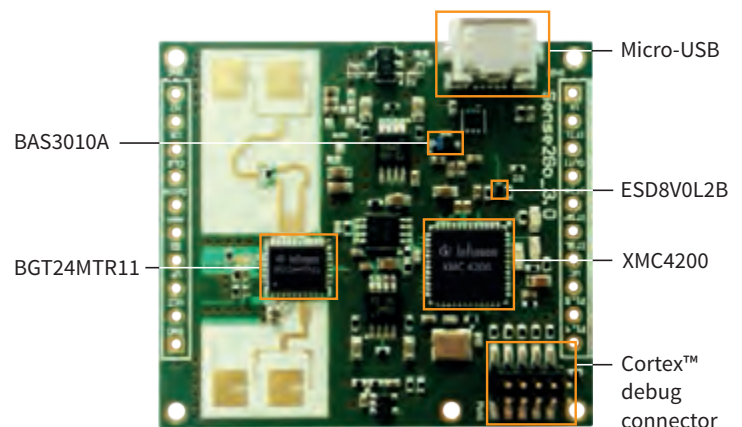

### Lighting applications

- > Street lighting
- > High bay lighting, e.g. warehouses
- > Parking garage lighting
- > Mining lights

### Features & benefits

- > Temperature range: -40 °C ~ 105 °C
- > Detection range up to 50 m @ 500 mW power consumption (BGT24MTR11)
- > Lower power consumption of 50 mW @ 10% duty cycle mode (BGT24MTR11)
- > Accuracy in cm-range for near-field operation
- > Fully integrated solution, only 1 external blocking capacitor required
- > Enabler for using standard dielectric PCB material (Rogers) and assembly lines for reducing the design-cycle time and production cost by a factor of ~4

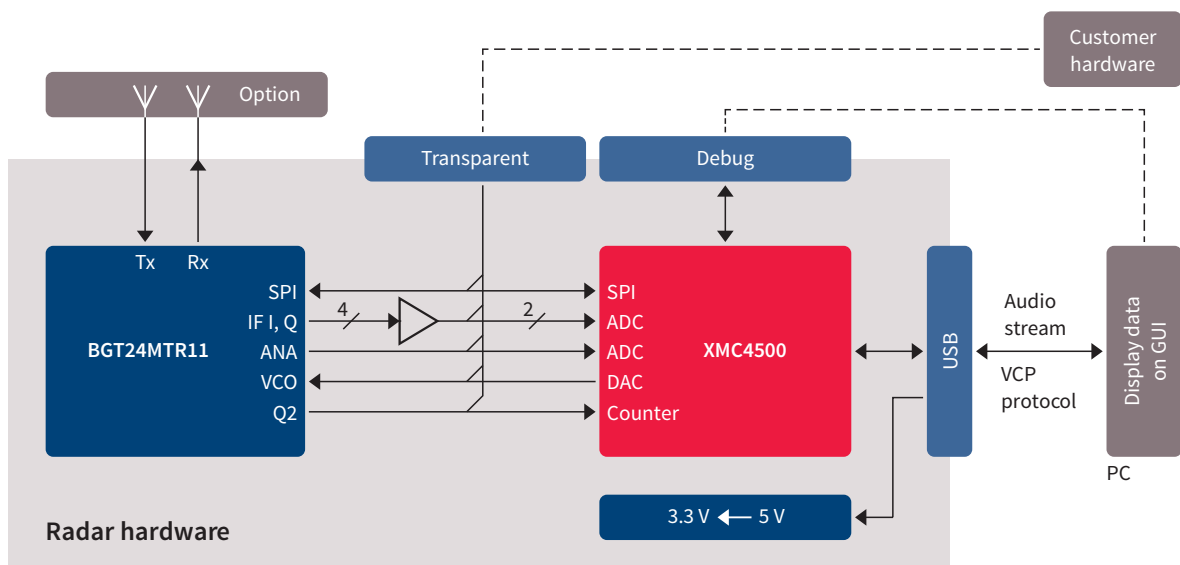

From hotline support to a complete solution – Infineon’s System Design House partners offer all stages of support to get your radar system up and running.



RFbeam Microwave GmbH

# Secured smart lighting – counterfeit protection and a secured network

## Protection against counterfeit light bulbs for improved system reliability and user safety

Both systems and users are increasingly endangered by counterfeit light bulbs. These fakes are produced at the lowest-possible cost and often come with a reduced brightness, shorter lifetime or even worse, the threat of catching fire. As the users of lighting equipment, both consumers and businesses need to be protected from hazardous or low-quality material and the OEM needs to be safeguarded against image damage and revenue loss. The solution lies in providing each bulb with the ability to authenticate itself, which can be done by using the OPTIGA™ Trust or the OPTIGA™ Trust E turnkey authentication solutions.

### The solution

The OPTIGA™ chip is integrated into the accessory – e.g. the light bulb. Once it is connected to the lighting management system (host system), an authentication procedure is run. The host system sends a challenge to the accessory which the accessory responds to using the key stored in the OPTIGA™ Trust (SLS10ERE).

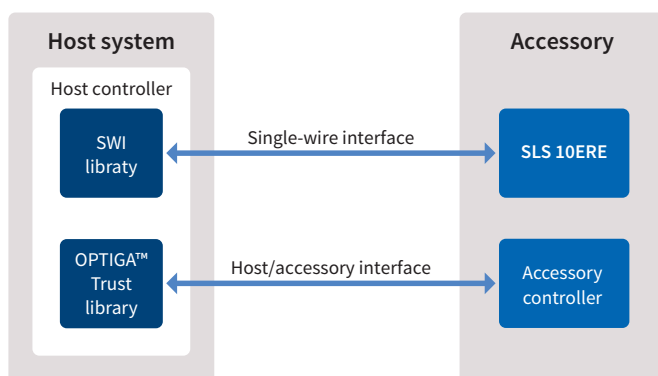

## OPTIGA™ Trust and OPTIGA™ Trust E

Easy-to-integrate, turnkey authentication solutions for protection against counterfeit products



## Protection against unauthorized system access and control or loss of confidential data

As connectivity increases, the amount of data transferred inside a light management system grows and becomes increasingly attractive to outside intruders. Stringent security measures need to be implemented to protect the data, users and services related to the system. A light management system needs to be protected so that it doesn't act as a gateway to the building or home network. It's crucial for all users to avoid leaking information about the home-and-away schedule and or break into services related to the light management system.

### The solution

This can be done with the OPTIGA™ family security solutions. These solutions support protection against access by unauthorized parties, while system components that can properly authenticate themselves will be allowed to access the network. Data is encrypted based on cryptographic keys which are securely stored in the OPTIGA™ security controller. Infineon offers a broad portfolio of authentication as well as security ICs, which are not only robust but also cost-effective, to address the needs of comprehensive lighting ecosystems: from intelligent lamps to bridges to light management systems.

## OPTIGA™ Trust and OPTIGA™ TPM

OPTIGA™ Trust P (SLJ 52ACA) is a high-security, feature-rich solution. As a fully programmable chip, it is a highly flexible and robust solution that supports the full range of functions. OPTIGA™ TPM (Trusted Platform Module) is a standardized security controller that protects the integrity and authenticity of devices and systems in embedded networks.



[www.infineon.com/optiga-embedded-security-solutions](http://www.infineon.com/optiga-embedded-security-solutions)



# LED strips & multichannel LED applications

A wide range of LED applications require a constant voltage LED driver with multiple LED strings or LED channels etc. Each LED string needs an LED driver IC, usually a linear LED driver IC for up to 200 mA LED current, and a switch-mode LED driver IC for higher LED drive currents.

The LED driver ICs consist of two main product families

- › The BCR series is the smallest-size and lowest-cost product family for linear LED driver ICs.
- › The ILD series features DC/DC LED driver ICs with the highest efficiency.

## Family overview of LED driver ICs for general lighting applications

Both families come with a line-up of regulators with an integrated power stage and a line-up of controllers that allow the utmost scalability via flexible dimensioning of the output stage.

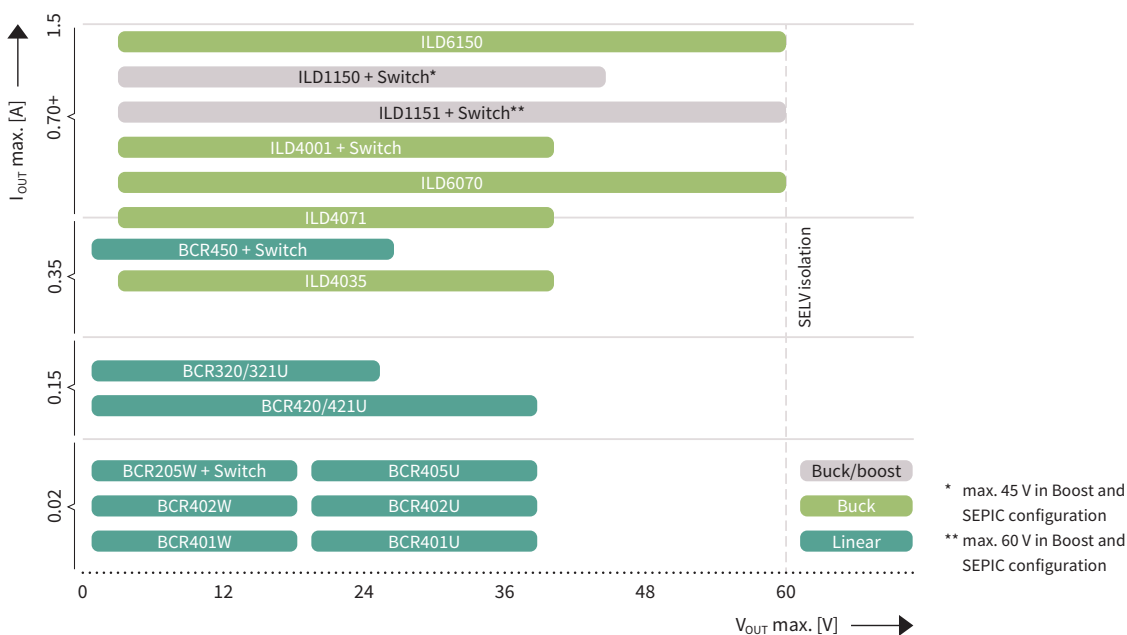

# Linear LED Driver ICs

The BCR linear LED drivers are perfectly suited for driving LED currents from 10 mA to 250 mA, making them the ideal choice for low- to mid-power LEDs in general lighting applications.

This represents the lowest-cost solution that requires an ultra-low external part count and PCB space. The light output can be adjusted via an external resistor. PWM dimming is supported either by a microcontroller interface or by means of an external digital transistor.

Thanks to its negative thermal coefficient, the LED load will be protected from overheating.



## Low-power LED driver ICs (5–65 mA)

Product type	Group	Topology	V <sub>S</sub> (min) [V]	V <sub>S</sub> (max) [V]	I <sub>out</sub> (typ) [mA]	I <sub>out</sub> (max) [mA]	Dimming	Package	P <sub>tot</sub> (max) [mW]
BCR205W	LED controller	Linear	1.8	18	0.5	ext. switch	no	SOT343	100
BCR401U	LED drivers for low-power LEDs	Linear	1.4 + V <sub>fLED</sub>	40	10	65	Digital	SC74	750
BCR401W	LED drivers for low-power LEDs	Linear	1.2 + V <sub>fLED</sub>	18	10	60	Digital	SOT343	500
BCR402U	LED drivers for low-power LEDs	Linear	1.4 + V <sub>fLED</sub>	40	20	65	Digital	SC74	750
BCR402W	LED drivers for low-power LEDs	Linear	1.4 + V <sub>fLED</sub>	18	20	60	Digital	SOT343	500
BCR405U	LED drivers for low-power LEDs	Linear	1.4 + V <sub>fLED</sub>	40	50	65	Digital	SC74	750

## Medium- & high-power LED driver ICs (65–500 mA)

Product type	Group	Topology	V <sub>S</sub> (min) [V]	V <sub>S</sub> (max) [V]	I <sub>out</sub> (typ) [mA]	I <sub>out</sub> (max) [mA]	Dimming	Package	P <sub>tot</sub> (max) [mW]
BCR320U	LED drivers for mid-power LEDs	Linear	1.4 + V <sub>fLED</sub>	24 + V <sub>fLED</sub>	250	300	no	SC74	1
BCR321U	LED drivers for mid-power LEDs	Linear	1.4 + V <sub>fLED</sub>	24 + V <sub>fLED</sub>	250	300	Digital	SC74	1
BCR420U	LED drivers for mid-power LEDs	Linear	1.4 + V <sub>fLED</sub>	40 + V <sub>fLED</sub>	150	200	no	SC74	1
BCR421U	LED drivers for mid-power LEDs	Linear	1.4 + V <sub>fLED</sub>	40 + V <sub>fLED</sub>	150	200	Digital	SC74	1
BCR450	LED controller	Linear	3	27	70	ext. switch	Digital	SC74	500
TLE4309G	LED drivers for linear high-power LEDs	Linear	4.5	24	500	500	Digital	TO263	–

## Application example – LED strips with low-power LEDs $I_{out}$ for 10–60 mA

### Application example with BCR402W

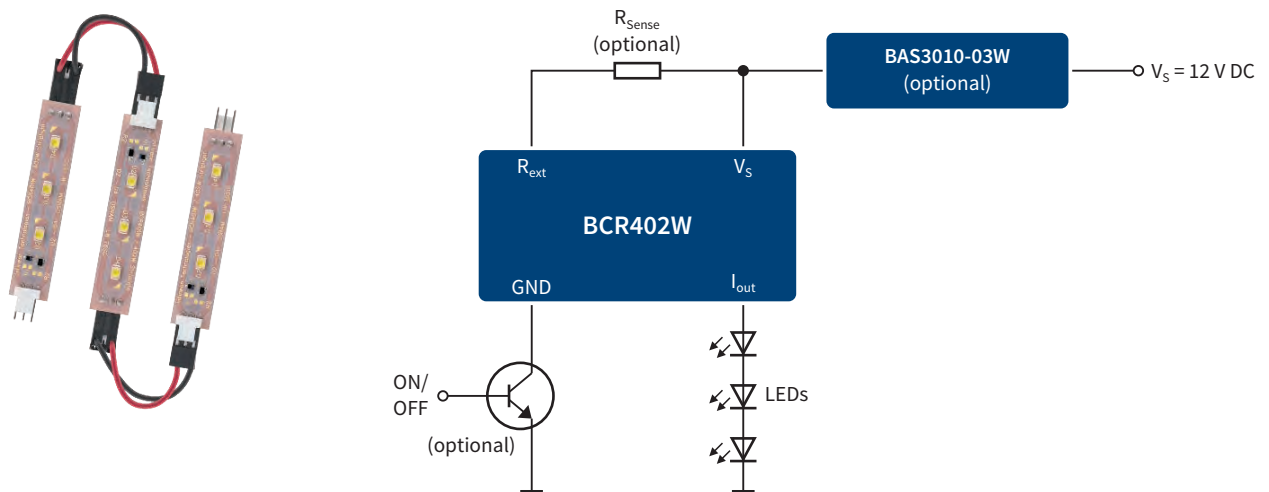

#### Features & benefits

- > Homogenous light output in different LED strings
- > Easy to implement with a low component count
- > No resistor required for common currents such as 10 mA/20 mA
- > Flexibility to adjust the current via an external resistor from 10 mA up to 60 mA
- > Negative thermal coefficient protecting the lifetime of LEDs

#### Infinion component list

Product type	Description
BCR402W	Low-power LED driver
BAS3010A-03W	Schottky diode for reverse polarity protection (RPP) – 12 V board
BAT64-03W	Schottky diode for reverse polarity protection (RPP) – 24 V board

#### Related application note

Description
Comparison of resistor biasing versus BCR401W / BCR402W LED driver biasing of +12 V & +24 V DC low-current LED striplights

#### Related evaluation board

Board name	Product	Description	Order number
12V low-current LED demoboard	BCR402W BAS3010A-03W	12 V BCR402W demoboard driving 3x 0.2 W LEDs in series	BCR402W 12 V LED board
24V low-current LED demoboard	BCR402W BAT64-03W	24 V BCR402W demoboard driving 6x 0.2 W LEDs in series	BCR402W 24 V LED board

## Application example – LED strip with mid-power LEDs $I_{out}$ for 65–200 mA

### Application example with BCR320U

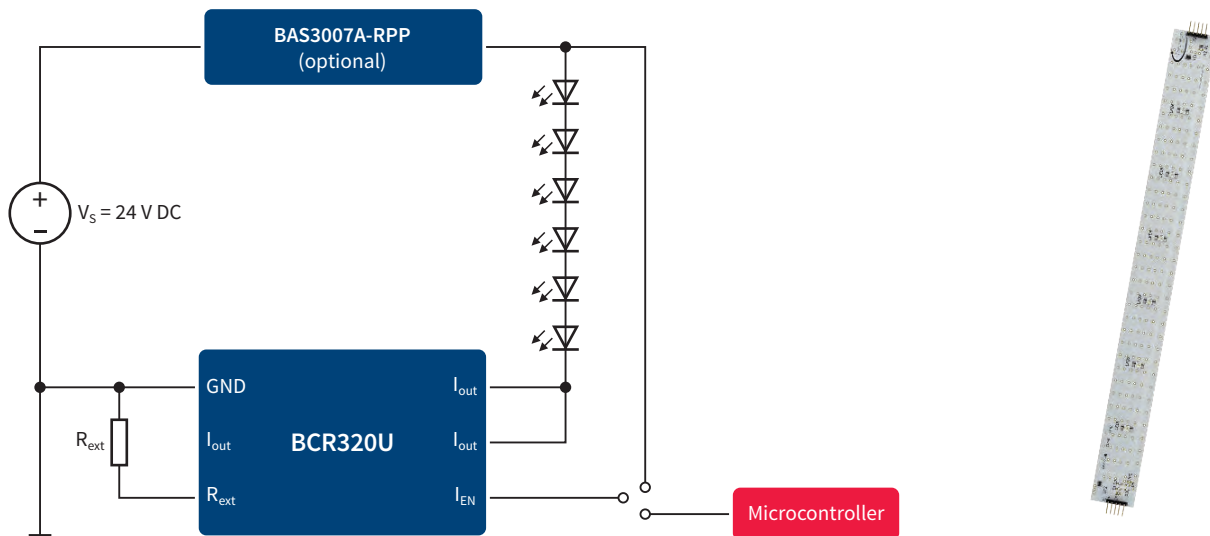

### Features & benefits

- > Homogenous light output in different LED strings regardless of  $V_f$  and supply voltage
- > Easy to implement with a low component count
- > Flexibility to adjust the current via an external resistor from 10 mA up to 250 mA
- > Direct microcontroller interface for PWM dimming for BCR421U and BCR321U or dimming via PWM power
- > Negative thermal coefficient protecting the lifetime of LEDs
- > High-power dissipation capability

### Infineon component list

Product type	Description
BCR320U	Medium-power LED driver
BAS3007A-RPP	Schottky bridge for reverse polarity protection (RPP)

### Related application note

Info number	Description
AN212	Driving half-watt LEDs on a lightstrip with BCR320U, BCR321U or BCR420U, BCR421U

### Related evaluation board

Board name	Product	Description	Order number
24V half-watt LED demoboard	BCR320U BAS3007A-RPP	24 V BCR320U striplight demoboard driving 6x 0.5 W LEDs in series	BCR320U HW LED board

# DC/DC LED driver ICs

Infineon has a broad portfolio of DC/DC LED drivers that support currents from 150 mA to 3 A, making them the ideal choice for high- and ultra-high-power LEDs In general lighting applications.

The buck topology is supported by the ILD4000 and ILD6000 families. Buck/boost, boost and SEPIC configuration are supported by the ILD1150 family. The ILD4000 is the low-cost DC/DC LED driver IC family with a breakdown voltage of 40 V and basic thermal protection. The ILD6000 is the feature-rich DC/DC LED driver IC family with a breakdown voltage of 60 V and advanced thermal protection.

Efficiency can be as high as 98% across a wide range of operation conditions. For the vast majority of buck LED drivers, users have the choice of dimming concepts: PWM or analog voltage.

Integrated smart thermal protection, along with over-voltage and overcurrent protection, contribute to a longer LED lifetime.

## LED driver ICs for buck topology

Product type	Group	V <sub>S</sub> (min) [V]	V <sub>S</sub> (max) [V]	I <sub>out</sub> (typ) [mA]	I <sub>out</sub> (max) [mA]	Dimming	Package	P <sub>tot</sub> (max) [mW]
ILD4001	LED controller	4.5	42	10	ext. switch	Analog or digital	SC74	500
ILD4035	LED drivers for buck high-power LEDs	4.5	40	350	400	Analog or digital	SC74	1000
ILD4071	LED drivers for buck high-power LEDs	5	40	100	700	Analog or digital	DSO-8	–
ILD6070	LED drivers for buck high-power LEDs	4.5	60	700	700	Analog or digital	DSO-8	–
ILD6150	LED drivers for buck high-power LEDs	4.5	60	1500	1500	Analog or digital	DSO-8	–

## LED driver ICs for buck/boost, boost and SEPIC topology

Product type	Group	V <sub>S</sub> (min) [V]	V <sub>S</sub> (max) [V]	I <sub>out</sub> (typ) [mA]	I <sub>out</sub> (max) [mA]	Dimming	Package	P <sub>tot</sub> (max) [mW]
ILD1150	LED controller	–	45	90	ext. switch	Digital	SSOP-14	–
ILD1151	LED controller	–	45	90	ext. switch	Analog or digital	SSOP-14	–

## Application example – Driving high-power LEDs

### Application example with DC/DC buck converter ILD6070/6150 (max. 60 V supply voltage)

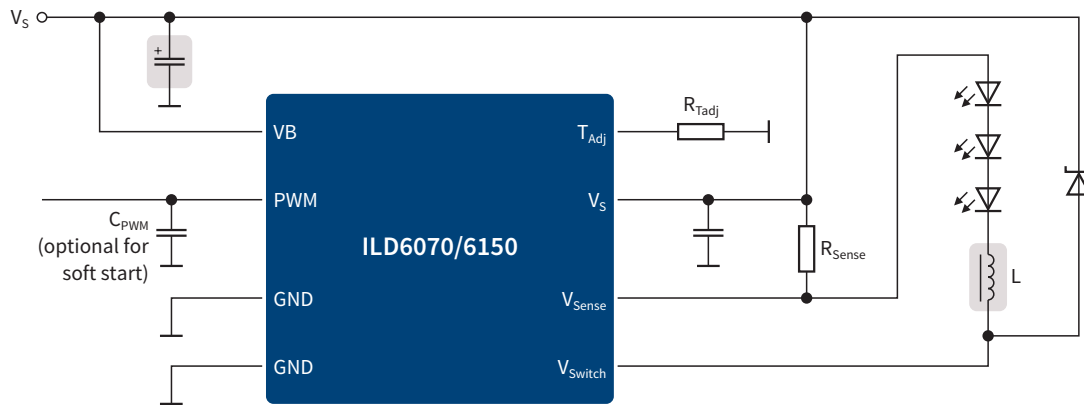

#### Features & benefits

- > Wide usable input voltage from 4.5–60 V
- > Compatible with a big variety of LEDs with an output current of 1500 mA
- > Provides both PWM or analog dimming options
- > More lumen/watt due to high efficiency of up to 98%
- > High output current accuracy  $\pm 3\%$  enables adjustment of the required light color and light intensity
- > Contrast ratio 3000:1
- > Small DSO-8 exposed pad package
- > Advanced thermal protection including (for details, please refer to the next page)
  - Current reduction in a slope enables the protection of LED lifetime
  - Trigger point of thermal protection can be adjusted
  - No need for external NTC or PTC, thereby reducing system cost
  - Light color doesn't change during thermal protection mode

#### Infineon component list

Part number	Description
ILD6070/6150	LED driver IC

#### Related application note

Info document	Description
Application note AN-EVAL-ILD6070	60 V/0.7 A highly efficient step-down LED driver with adjustable thermal protection
Application note AN-EVAL-ILD6150	60 V/1.5 A highly efficient step-down LED driver with adjustable thermal protection

#### Related evaluation board

Part number	Description
Evaluation board EVALLED-ILD6070	ILD6070 60 V/0.7 A highly efficient step-down LED driver with adjustable thermal protection
Evaluation board EVALLED-ILD6150	ILD6150 60 V/1.5 A highly efficient step-down LED driver with adjustable thermal protection

## Advanced thermal protection with the ILD6000 family

Managing the heat emitted from the LED components and electronics is a key challenge in implementing high-quality and durable LED lighting systems. The most common way luminary designers handle thermal management is by designing the heatsink for worst-case scenarios. These worst cases may occur very rarely or never during the lifetime of the LED lighting system. Designing the heatsink for the worst-case scenario results in a high system cost.

Thanks to the patent-pending smart thermal management technology used in the ILD6000 LED driver family, the lifetime and cost of LED designs can be significantly improved. This results in various benefits for luminary manufacturers and end users:

- › Current reduction in a slope enables
  - Starting thermal protection at a lower temperature range (example 100 °C to 120 °C). Protection starting at such temperature levels allows protection of the LED lifetime
  - No outage of light during thermal protection mode
  - Sufficient light will be available in most cases

- › Reduced system cost for thermal protection since
  - No NTC is required if the driver IC can be thermally coupled to the LEDs
  - Heatsink design can be optimized for the most likely use cases, not for the worst case
- › Flexibility to
  - Use the LED driver IC with or without an NTC
  - External NTC can be used if the LED driver is separated from the LED light engine
  - Adjust the temperature for triggering the start of thermal protection depending on the end customer and application needs (see graph below)
- › The light color doesn't change during the thermal protection mode – the end user might not realize that the LED system is in thermal protection mode (see graph below)
- › Improved total cost of ownership due to increasing the lifetime of the LED system

### Adjustable trigger for thermal protection

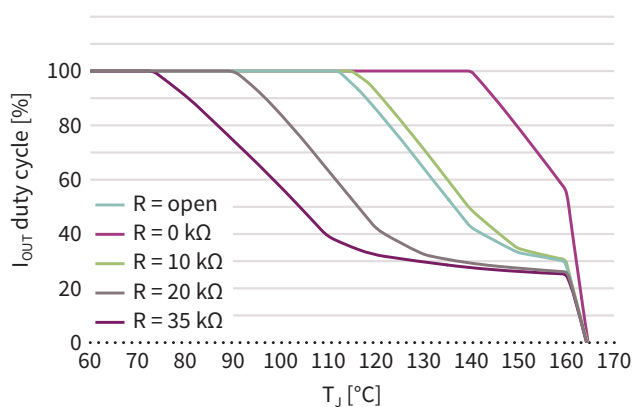

### PWM modulated light output keeps color constant during thermal protection

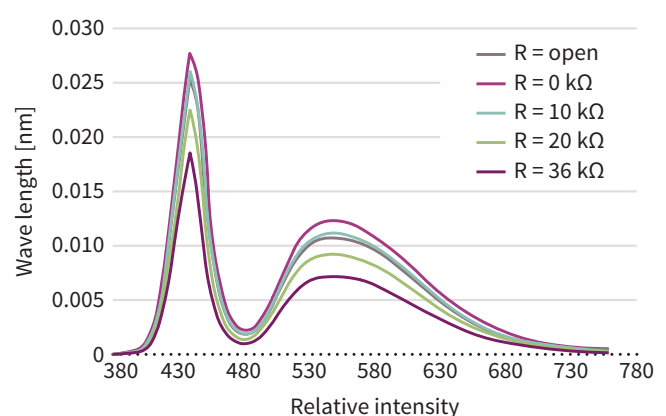

## Application example – Driving high-power LEDs

### Application example with ILD4035, 350 mA in a small SC74 package

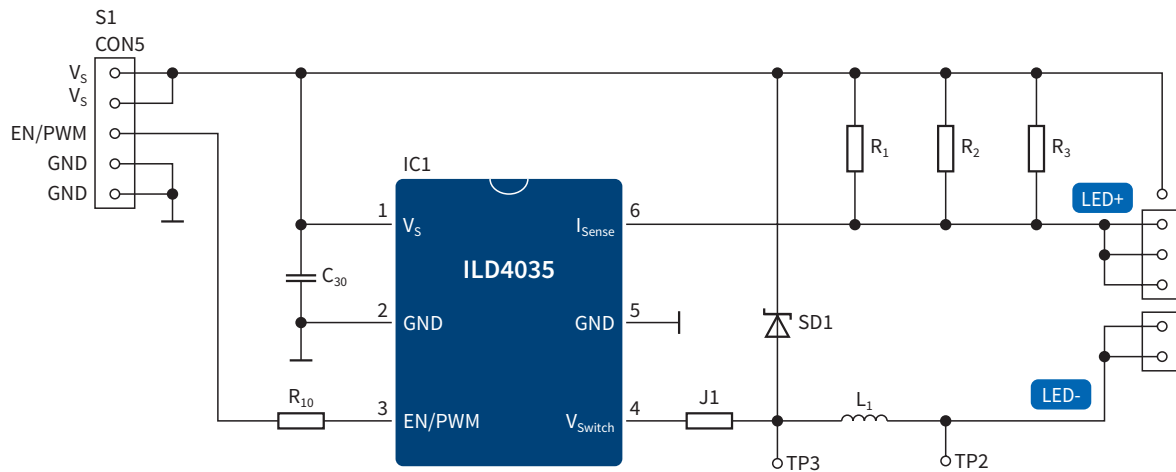

#### Key features & benefits

- > Input voltage from 4.5–40 V
- > Designed to meet required cost – ILD4035 for driving LEDs up to 350 mA
- > High output current accuracy  $\pm 3\%$
- > Contrast ratio 1000:1
- > Overtemperature protection
  - Current reduction in a slope enables protection of the LED lifetime
  - No external NTC/PTC required
  - No outage of light during thermal protection mode
  - Enables optimized heatsink design

#### Infineon component list

Part number	Description
ILD4035	LED driver IC
BAS3010	Schottky diode

#### Related application note

Info number	Description
AN 215	Driving 1 W LEDs with ILD4035

#### Related evaluation board

Part number	Description
Evaluation board ILD4035 24V	Drive 1 W LEDs with the buck LED driver ILD4035. 24 V and 12 V supply voltage version are available. The 350 mA preset LED current analog voltage and PWM pin for dimming can be connected to a string of 1 W LEDs.

### Application example with ILD4001, scalable from 200 mA to 3 A

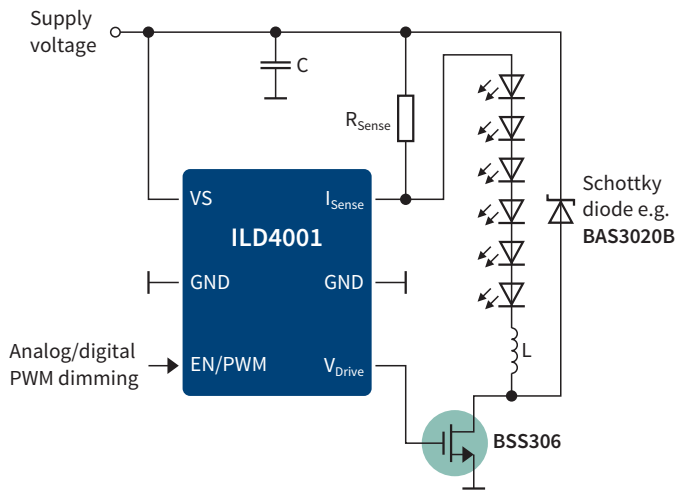

#### Key features & benefits

- > Input voltage range: 4.5–40 V
- > Designed to meet required cost
- > Scalable output current from 200 mA up to 3 A
- > Up to 98% efficiency
- > Supports analog and PWM dimming
- > Temperature shutdown mechanism
- > Highest flexibility with one IC for various designs and driving high- to ultra-high-power LEDs

#### Infinion component list

Info document	Description
ILD4120	LED driver IC
BAS3020B	Schottky diode
BSS306	Small signal MOSFET

#### Related application note

Info number	Description
AN 213	Driving 2–5 W LEDs with ILD4001

#### Related evaluation board

Part number	Description
ILD4001 0.7 A board	Evaluation board for high-power LEDs at ILD4001 0.7 A board DC voltage input using ILD4001
ILD4001 1 A board	Evaluation board for high-power LEDs at ILD4001 1 A board DC voltage input using ILD4001

#### Small signal MOSFETs for LED drivers – N-channel MOSFETs

Voltage [V]	SOT-223	SOT89	SC59	SOT23
30			BSR302N $R_{DS(on)} = 23 \text{ m}\Omega$	BSS306N $R_{DS(on)} = 57 \text{ m}\Omega$
60	BSP318S $R_{DS(on)} = 90 \text{ m}\Omega$	BSS606N $R_{DS(on)} = 60 \text{ m}\Omega$	BSR606N $R_{DS(on)} = 60 \text{ m}\Omega$	2N7002 $R_{DS(on)} = 3 \Omega$
	BSP320S $R_{DS(on)} = 120 \text{ m}\Omega$			
	BSP295 $R_{DS(on)} = 300 \text{ m}\Omega$			
100	BSP373N $R_{DS(on)} = 240 \text{ m}\Omega$			BSS169 $R_{DS(on)} = 12 \Omega$
	BSP372N $R_{DS(on)} = 230 \text{ m}\Omega$			BSS119N $R_{DS(on)} = 6 \Omega$
	BSP296N $R_{DS(on)} = 600 \text{ m}\Omega$			BSS123N $R_{DS(on)} = 6 \Omega$



## LED retrofit lamps

Our primary focus on LED retrofit lamps involves:

› LED tubes

In the case of LED tubes, the LED controller ICL8201 supports a non-isolated buck topology in a cascode set-up. The cascode combines a fast time-to-light with efficient operation since no start-up resistors have to be used as in non-cascode set-ups. High efficiency enables a lower system cost by reducing the cost for the heatsink, generating the same amount of light with fewer LEDs and a longer lifetime of the LED lamp. The long lifetime of the LED lamp is also supported by the thermal protection feature.





# CoolMOS™ CE – focus on efficiency, cost-effectiveness and part availability

Good efficiency, ease-of-use and EMI performance at an attractive cost position make the CoolMOS™ CE series the product of choice for LED drivers or LED tubes in buck, flyback, PFC and LLC topology. Its benefits include an improvement in efficiency and thermal behavior compared to standard MOSFETs.

CoolMOS™ products aimed at lighting bring the benefits of highest quality and delivery reliability as outlined in the overview section for the CoolMOS™ portfolio. However, the CoolMOS™ CE series has been defined with a particular focus on the customers' needs, for an attractive price and fastest supply availability: at any given time and for any product of the CoolMOS™ CE series, orders of up to 30 k units can be shipped from our distribution center within 5 days.

## Further reasons to choose CoolMOS™ CE

Non-technical benefits provided by CoolMOS™	CE
Product portfolio	We own a broad portfolio covering five voltage classes in both through-hole and SMD packages.
Capacity	We own the world's largest capacity for power devices, with three dedicated frontends and four backends. Thanks to factors such as the continued investment in our production facilities, we ensure a secure supply during a market upswing.
Lead time	We understand consumer and lighting market dynamics and offer a lead time as short as 5 days.
Delivery performance	Our supply chain performance is constantly greater than or equal to 96 percent (adhering to the customer committed date).
Quality	Our field failure rates are as low as 0.1 PPM.
Design-in support	We have a large field application engineering team dedicated to providing professional and flexible support for your design.

## CoolMOS™ CE in an SOT-223 package

With the rapid conversion from CFL to LED lighting, customer requirements are rapidly changing: on the one hand, power levels are further decreasing, while on the other hand, increasing cost pressure compels power designers to optimize designs to a fraction of a cent. The completion

of the CoolMOS™ CE portfolio with the SOT-223 package is Infineon's answer to this challenge: it facilitates a further reduction in BOM cost – and additional footprint optimization in some designs – with only a minor compromise in terms of thermal behavior.

### SOT-223 as drop-in replacement for DPAK at a lower cost

The SOT-223 package with a decapped middle pin is fully compatible with the footprint of a DPAK, therefore allowing one-on-one drop-in replacements and second sourcing.

## SOT-223 as drop-in replacement for DPAK at a lower cost

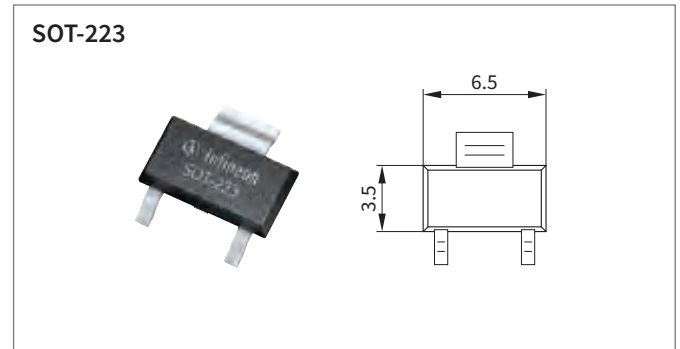
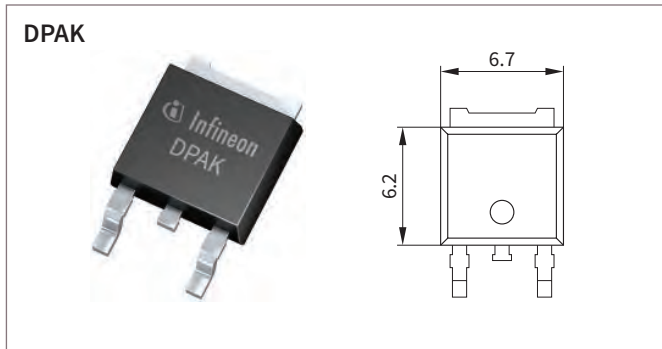

## Thermal behavior – on a par with DPAK

The thermal behavior of the SOT-223 primarily depends on the layout of the board where the package is used and on the power consumed. We have measured the thermals in

a test environment and compared them with a simulation. Compared to a DPAK positioned on a typical DPAK footprint, the SOT-223 displays the following thermal behavior:

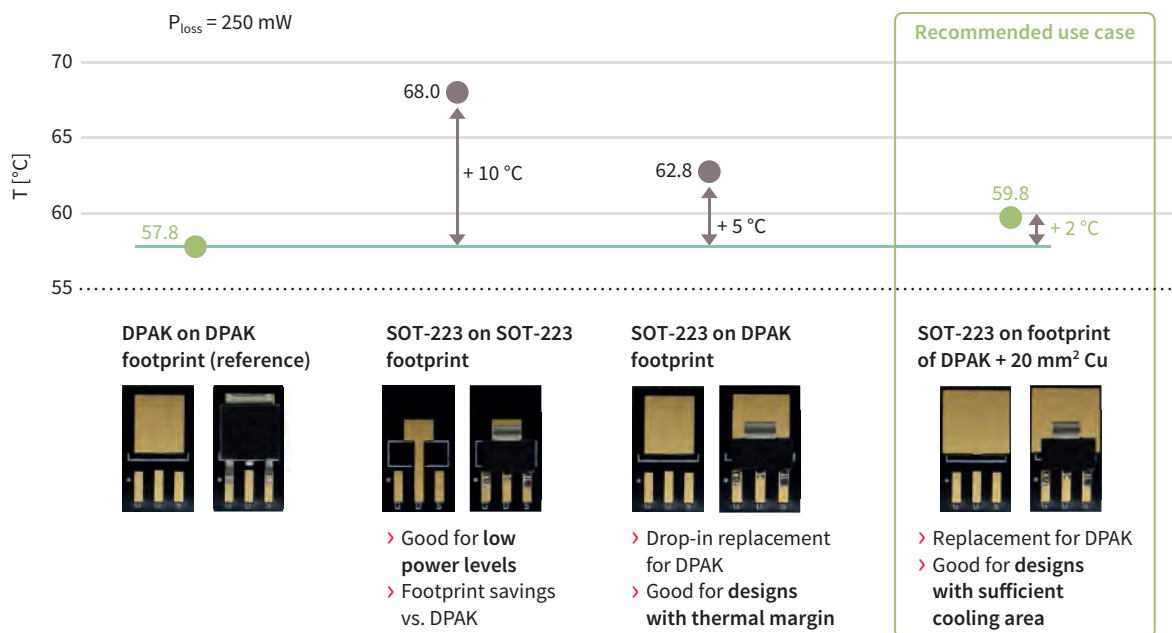

- > **Same footprint as DPAK** – when mounted on a standard DPAK footprint, the SOT-223 package shows a temperature elevated by 4–5 K. This behavior makes the SOT-223 suitable for designs with a thermal margin
- > **Footprint of DPAK plus ~20 mm<sup>2</sup> additional copper area** – in many designs, the MOSFET is mounted on a larger Cu area which serves as a heatsink embedded in the PCB. As soon as 20 mm<sup>2</sup> Cu or more is available in addition to

the DPAK footprint, the temperature increase is no more than 2–3 K above DPAK and the SOT-223 can be used as a drop-in replacement

- > **SOT-223 on SOT-223 footprint** – when mounted on the SOT-223 footprint without an additional surrounding Cu area, the package leads to a 10 °C temperature increase compared to a DPAK. This means that the option of space savings via the SOT-223 is only useful for very low power applications

## Thermal behavior – on a par with DPAK

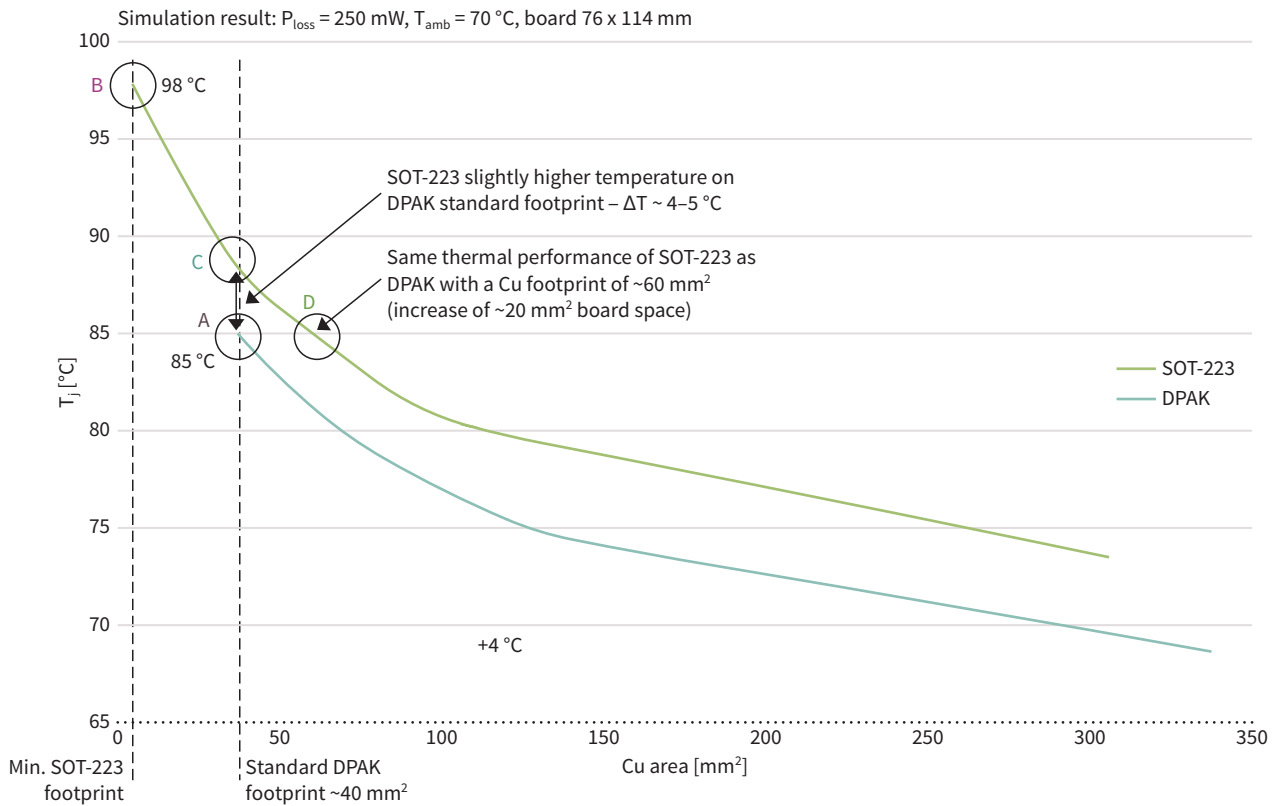

The laboratory findings on thermal behavior are confirmed by a thermal simulation with  $T_{\text{ambient}} = 70 \text{ }^\circ\text{C}$  and  $P_{\text{loss}} = 250 \text{ mW}$ . The size of the copper area in the footprint is shown on the x-axis, while the y-axis displays the temperature of the package top side. In the case of an SOT-223

on DPAK footprint, the 4–5 K temperature increase over DPAK is confirmed. But when used in conjunction with an enlarged copper area of  $\sim 20 \text{ mm}^2$ , a temperature increase of 2–3 K is measured.

## CoolMOS™ CE SOT-223 product portfolio

$R_{\text{DS(ON)}} [m\Omega]$	500 V	600 V	650 V	700 V
3400		IPN60R3K4CE		
3000	IPN50R3K0CE			
2000/2100	IPN50R2K0CE	IPN60R2K1CE		
1400/1500	IPN50R1K4CE	IPN60R1K5CE	IPN65R1K5CE	IPN70R1K5CE
950/1000	IPN50R950CE	IPN60R1K0CE		
800	IPN50R800CE			
650	IPN50R650CE			

# LightDesk: lighting selection & design tool

The new Lighting Application Finder enables you to quickly select, design, simulate and buy the right lighting circuit for your application requirements.

The tool comprises residential, commercial, outdoor & architectural – as well as automotive – lighting solutions for various technologies, such as LED, fluorescent, HID, xenon or bulbs.

- › Explore the vast Infineon lighting portfolio with more than 1,000 parts (linear and DC/DC driver and controller ICs,  $\mu$ C, MOSFETs, smart high-side switches etc.)
- › Design & simulate your solution online
- › Offline simulation: download the SIMetrix engine, schematics, SPICE models etc.
- › Buy the BOM online via Arrow, Digikey, Mouser and Chip1Stop.

**Input Requirements**

Select Lighting Application

AC/DC  DC/DC  Linear

Input Voltage 0 - 400 V

Min. Output Power 1 W

**Possible Solutions 15**

Medium/High Power LED Linear Design (60-700 mA)	LED	Linear	12.0 W	75%	<input type="button" value="Design it"/>
Dimmable LED Retrofit Lamp Design (220VAC 13W Bulb)	LED	Flyback, PFC	11.0 W	85%	<input type="button" value="Design it"/>
LED Driver Design (12VAC 7W/10W MR16)	LED	Buck	10.0 W	89%	<input type="button" value="Design it"/>
Dimmable LED Retrofit Lamp Design (120VAC 12W Bulb)	LED	Buck	10.0 W	88%	<input type="button" value="Design it"/>
Automotive High Power LED Lighting (12VDC)	LED	SEPIC	5.0 W	95%	<input type="button" value="Design it"/>
LED Driver Design (12VAC 3W MR16)	LED	Buck	3.0 W	88%	<input type="button" value="Design it"/>
Medium- and High-Power LED Linear Design (65-500 mA)	LED	Linear	2.0 W	75%	<input type="button" value="Design it"/>
<b>High Power LED DC/DC Design (5-60VDC 700/1500mA)</b>	LED	Buck	1.5 W	96%	<input type="button" value="Design it"/>
Low Power LED Linear Design (5-65 mA)	LED	Linear	1.2 W	75%	<input type="button" value="Design it"/>
Light Management (DALI, DMX512)	LED	Linear	1.2 W	80%	<input type="button" value="Design it"/>
High Power LED DC/DC Design (12/24VDC 400mA)	LED	Buck	1.0 W	85%	<input type="button" value="Design it"/>

**High Power LED DC/DC Design (5-60VDC 700/1500mA)**

LED DC/DC Driver IC (Buck)

The ILD6150 is a hysteretic buck LED driver IC for driving high power LEDs in general lighting applications with average currents up to 1.5 A.

**Key Features & Benefits:**

- Wide input voltage range from 4.5 V to 60 V
- Capable to provide up to 1.5 A output current (3% accuracy)
- Soft-start capability
- Analog and PWM dimming possible
- Very low LED current drift over temperature
- Under-voltage lockout
- Over current protection
- Adjustable over-temperature protection reducing thermal load by decreasing the current

**APPLICATION STATUS:**

WebSIMO technology: sophisticated online design and support solutions for semiconductor and other products. For more information please visit [www.transim.com](http://www.transim.com)

Version: 2.3.11.125661

POWERED BY **WebSIM**

# Evaluation boards & kits

Board name	Product	Description	Order number
230 V isolated dimmable LED bulb board	ICL8002G SPD02N80C3	Demoboard for dimmable 13 W LED bulb in isolated flyback topology	EVALLED-ICL8002G-B1
120 V non-isolated dimmable LED bulb board	ICL8002G IPD60R2K0C6	Demoboard for dimmable 12 W LED bulb in non-isolated buck topology	EVALLED-ICL8002G-B2
120 V isolated dimmable LED PAR38 board	CL8002G IPI60R190C6 IPD60R600C6 BSS225	Demoboard for dimmable 20 W LED PAR38 in isolated flyback topology	EVALLED-ICL8002G-B3
ILD4001 0.7 A board	ILD4001 BSR302N	Evaluation board for high-power LEDs at ILD4001 0.7 A board DC voltage input using ILD4001	ILD4001 0.7 A board
ILD4001 1 A board	ILD4001 BSP318S	Evaluation board for high-power LEDs at ILD4001 1 A board DC voltage input using ILD4001	ILD4001 1 A board
ILD4035 12 V board	ILD4035	Evaluation board for high-power LEDs at ILD4035 12 V board 12 DC voltage input using ILD4035	ILD4035 12 V board
ILD4035 24 V board	ILD4035	Evaluation board for high-power LEDs at ILD4035 24 V board 24 DC voltage input using ILD4035	ILD4035 24 V board
ILD1151 in boost topology	ILD1151	Boost to GND configuration + short to GND protection (B2G + S2G) – topology BOOST	Demoboard ILD1151 Ver2
ILD1151 in buck-boost topology	ILD1151	Boost to battery (B2B) – topology BUCK/BOOST	Demoboard ILD1151 Ver3
ILD1151 in buck-boost topology (SEPIC configuration)	ILD1151	SEPIC configuration – topology BUCK/BOOST	Demoboard ILD1151 Ver4
BCR450 board	BCR450 BAS3007A-RPP	Evaluation board for mid- & high-power board LEDs voltage input using BCR450	BCR450 board
BCR320U board	BCR320U BAS3007A-RPP	Evaluation board for mid-power LEDs voltage input using BCR320U	BCR320U HW LED board
BCR402W 12 V board	BCR402W BAS3010A	LED strip for low-power LEDs voltage input using BCR402W	BCR402W 12 V LED board
BCR402W 24 V board	BCR402W BAT64-03W	LED strip for low-power LEDs voltage input using BCR402W	BCR402W 24 V LED board
ILD6070 board	ILD6070	Evaluation board for high-power LEDs at EVALLED-ILD6070DC voltage input using ILD6070	EVALLED-ILD6070
ILD6150 board	ILD6150	Evaluation board for high-power LEDs at EVALLED-ILD6150DC voltage input using ILD6150	EVALLED-ILD6150
LED lighting application kit	XMC1200	Microcontroller (32-bit)	KIT_XMC1x_AK_LED_001
XMC1200 boot kit	XMC1200	Microcontroller (32-bit)	KIT_XMC12_BOOT_001
Evaluation board ICL8105	ICL8105 .dp digital power 2.0	Evaluation system board 20–80 W for LED driver	EVALLEDICL8105E1
Demoboard ICL8105	ICL8105 .dp digital power 2.0	Demoboard 40 W for LED driver	EVALLEDICL8105F2
Evaluation board ILD2111	ILD21111 .dp digital power 2.0	Evaluation board output current from 250–800 mA for LED driver	EVALLEDILD2111E1
Interface board .dp	.dp digital power	Interface board to PC needed for design support of ICL8105 and ILD2111	www.hitex.com/dp
ICL5101 power supply demoboard	ICL5101, CoolMOS™ MOSFET	PFC/LLC evaluation board 110 W LED driver	EVALLEDICL5101E1
Evaluation board ICL8201	ICL8201, IPU50R3K0CE	GU10 LED lamp reference design	EVALLEDICL8201F1
Evaluation board ICL8201	ICL8201, IPS65R1K5CE	T8 LED tube reference design	EVALLEDICL8201F2
RGB LED shield with XMC1203 for Arduino	XMC1202	3-channel DC/DC buck LED driver kit, up to 48 V input voltage, up to 1 A peak current, DMX512 communication	KIT_LED_XMC1202_AS_01
XMC™ LED current control explorer	XMC1300	Single-channel DC/DC buck, up to 30 V DC input voltage, up to 1 A peak current, Dali communication	KIT_XMC1-LED-CCEXP-001
CoolDim10V Demoboard	CDM10V, ICL8105	CoolDim10V demoboard	SP001493168
IRXLED04 50 W Flyback Eval Board	IRS2982S, CoolMOS™ MOSFET 800 V CE	50 W Flyback converter design using the IRS2982 controller	



# Expert support for LED drivers

Easy access and high quality



Application notes, datasheets & more

[www.infineon.com/led.appnotes](http://www.infineon.com/led.appnotes)

[www.infineon.com/led.documents](http://www.infineon.com/led.documents)

[www.infineon.com/lowcostleddriver](http://www.infineon.com/lowcostleddriver)

[www.infineon.com/ledoffline](http://www.infineon.com/ledoffline)



Light  
Desk

LED driver online design tool

[www.infineon.com/lightdesk](http://www.infineon.com/lightdesk)



LED driver evaluation boards

[www.infineon.com/led.evalboards](http://www.infineon.com/led.evalboards)



Where to Buy

# Where to buy

Infineon distribution partners and sales offices:

[www.infineon.com/WhereToBuy](http://www.infineon.com/WhereToBuy)

# Service hotline

Infineon offers its toll-free 0800/4001 service hotline as one central number, available 24/7 in English, Mandarin and German.

- > Germany ..... 0800 951 951 951 (German/English)
- > China, mainland ..... 4001 200 951 (Mandarin/English)
- > India ..... 000 800 4402 951 (English)
- > USA ..... 1-866 951 9519 (English/German)
- > Other countries ..... 00\* 800 951 951 951 (English/German)
- > Direct access ..... +49 89 234-0 (interconnection fee, German/English)

\* Please note: Some countries may require you to dial a code other than "00" to access this international number.  
Please visit [www.infineon.com/service](http://www.infineon.com/service) for your country!



Mobile product catalog

Mobile app for iOS and Android.

[www.infineon.com](http://www.infineon.com)

Published by  
Infineon Technologies AG  
81726 Munich, Germany

© 2016 Infineon Technologies AG.  
All Rights Reserved.

Order Number: B127-I0226-V1-7600-EU-EC-P  
Date: 03 / 2016

#### Please note!

THIS DOCUMENT IS FOR INFORMATION PURPOSES ONLY AND ANY INFORMATION GIVEN HEREIN SHALL IN NO EVENT BE REGARDED AS A WARRANTY, GUARANTEE OR DESCRIPTION OF ANY FUNCTIONALITY, CONDITIONS AND/OR QUALITY OF OUR PRODUCTS OR ANY SUITABILITY FOR A PARTICULAR PURPOSE. WITH REGARD TO THE TECHNICAL SPECIFICATIONS OF OUR PRODUCTS, WE KINDLY ASK YOU TO REFER TO THE RELEVANT PRODUCT DATA SHEETS PROVIDED BY US. OUR CUSTOMERS AND THEIR TECHNICAL DEPARTMENTS ARE REQUIRED TO EVALUATE THE SUITABILITY OF OUR PRODUCTS FOR THE INTENDED APPLICATION.

WE RESERVE THE RIGHT TO CHANGE THIS DOCUMENT AND/OR THE INFORMATION GIVEN HEREIN AT ANY TIME.

#### Additional information

For further information on technologies, our products, the application of our products, delivery terms and conditions and/or prices, please contact your nearest Infineon Technologies office ([www.infineon.com](http://www.infineon.com)).



#### Warnings

Due to technical requirements, our products may contain dangerous substances. For information on the types in question, please contact your nearest Infineon Technologies office.





Except as otherwise explicitly approved by us in a written document signed by authorized representatives of Infineon Technologies, our products may not be used in any life-endangering applications, including but not limited to medical, nuclear, military, life-critical or any other applications where a failure of the product or any consequences of the use thereof can result in personal injury.

## Looking for pricing, stock, or lifecycle information?

Click below to explore more details on WIN SOURCE:

-  [View BCR402W 24V LED BOARD](#) on WIN SOURCE
-  [Infineon Technologies](#) Information

## Optimize Your Supply Chain with WIN SOURCE Solutions

-  Global Sourcing Solution
-  Obsolete Management
-  Cost Control Management
-  Shortage Management
-  Alternative Solution
-  Excess Inventory Management