



**THE DATASHEET OF
2ED020I12F2XUMA1**



EiceDRIVER™

2ED020I12-F2

Dual IGBT Driver IC

Final Data Sheet

Rev. 2.0, 2012-06-05

Industrial Power Control

Edition 2012-06-05

**Published by
Infineon Technologies AG
81726 Munich, Germany**

**© 2012 Infineon Technologies AG
All Rights Reserved.**

Legal Disclaimer

The information given in this document shall in no event be regarded as a guarantee of conditions or characteristics. With respect to any examples or hints given herein, any typical values stated herein and/or any information regarding the application of the device, Infineon Technologies hereby disclaims any and all warranties and liabilities of any kind, including without limitation, warranties of non-infringement of intellectual property rights of any third party.

Information

For further information on technology, delivery terms and conditions and prices, please contact the nearest Infineon Technologies Office (www.infineon.com).

Warnings

Due to technical requirements, components may contain dangerous substances. For information on the types in question, please contact the nearest Infineon Technologies Office.

Infineon Technologies components may be used in life-support devices or systems only with the express written approval of Infineon Technologies, if a failure of such components can reasonably be expected to cause the failure of that life-support device or system or to affect the safety or effectiveness of that device or system. Life support devices or systems are intended to be implanted in the human body or to support and/or maintain and sustain and/or protect human life. If they fail, it is reasonable to assume that the health of the user or other persons may be endangered.

Revision History

Page or Item	Subjects (major changes since previous revision)
Rev. 2.0, 2012-06-05	

Trademarks of Infineon Technologies AG

AURIX™, BlueMoon™, C166™, CanPAK™, CIPOS™, CIPURSE™, COMNEON™, EconoPACK™, CoolMOS™, CoolSET™, CORECONTROL™, CROSSAVE™, DAVE™, EasyPIM™, EconoBRIDGE™, EconoDUAL™, EconoPIM™, EiceDRIVER™, eupec™, FCOS™, HITFET™, HybridPACK™, I²RF™, ISOFACE™, IsoPACK™, MIPAQ™, ModSTACK™, my-d™, NovalithIC™, OmniTune™, OptiMOS™, ORIGA™, PRIMARION™, PrimePACK™, PrimeSTACK™, PRO-SIL™, PROFET™, RASIC™, ReverSave™, SatRIC™, SIEGET™, SINDRION™, SIPMOS™, SMARTi™, SmartLEWIS™, SOLID FLASH™, TEMPFET™, thinQ!™, TRENCHSTOP™, TriCore™, X-GOLD™, X-PMU™, XMM™, XPOSYS™.

Other Trademarks

Advance Design System™ (ADS) of Agilent Technologies, AMBA™, ARM™, MULTI-ICE™, KEIL™, PRIMECELL™, REALVIEW™, THUMB™, μVision™ of ARM Limited, UK. AUTOSAR™ is licensed by AUTOSAR development partnership. Bluetooth™ of Bluetooth SIG Inc. CAT-iq™ of DECT Forum. COLOSSUS™, FirstGPS™ of Trimble Navigation Ltd. EMV™ of EMVCo, LLC (Visa Holdings Inc.). EPCOS™ of Epcos AG. FLEXGO™ of Microsoft Corporation. FlexRay™ is licensed by FlexRay Consortium. HYPERTERMINAL™ of Hilgraeve Incorporated. IEC™ of Commission Electrotechnique Internationale. IrDA™ of Infrared Data Association Corporation. ISO™ of INTERNATIONAL ORGANIZATION FOR STANDARDIZATION. MATLAB™ of MathWorks, Inc. MAXIM™ of Maxim Integrated Products, Inc. MICROTEC™, NUCLEUS™ of Mentor Graphics Corporation. Mifare™ of NXP. MIPI™ of MIPI Alliance, Inc. MIPS™ of MIPS Technologies, Inc., USA. muRata™ of MURATA MANUFACTURING CO., MICROWAVE OFFICE™ (MWO) of Applied Wave Research Inc., OmniVision™ of OmniVision Technologies, Inc. Openwave™ Openwave Systems Inc. RED HAT™ Red Hat, Inc. RFMD™ RF Micro Devices, Inc. SIRIUS™ of Sirius Satellite Radio Inc. SOLARIS™ of Sun Microsystems, Inc. SPANSION™ of Spansion LLC Ltd. Symbian™ of Symbian Software Limited. TAIYO YUDEN™ of Taiyo Yuden Co. TEAKLITE™ of CEVA, Inc. TEKTRONIX™ of Tektronix Inc. TOKO™ of TOKO KABUSHIKI KAISHA TA. UNIX™ of X/Open Company Limited. VERILOG™, PALLADIUM™ of Cadence Design Systems, Inc. VLYNQ™ of Texas Instruments Incorporated. VXWORKS™, WIND RIVER™ of WIND RIVER SYSTEMS, INC. ZETEX™ of Diodes Zetex Limited.

Last Trademarks Update 2010-10-26

Table of Contents

	Table of Contents	4
	List of Figures	5
	List of Tables	6
1	Overview	7
2	Block Diagram	9
3	Pin Configuration and Functionality	10
3.1	Pin Configuration	10
3.2	Pin Functionality	11
4	Functional Description	13
4.1	Introduction	13
4.2	Supply	13
4.3	Internal Protection Features	14
4.3.1	Undervoltage Lockout (UVLO)	14
4.3.2	READY Status Output	14
4.3.3	Watchdog Timer	15
4.3.4	Active Shut-Down	15
4.4	Non-Inverting and Inverting Inputs	15
4.5	Driver Outputs	15
4.6	External Protection Features	15
4.6.1	Desaturation Protection	15
4.6.2	Active Miller Clamp	15
4.6.3	Short Circuit Clamping	15
4.7	RESET	15
5	Electrical Parameters	16
5.1	Absolute Maximum Ratings	16
5.2	Operating Parameters	18
5.3	Recommended Operating Parameters	18
5.4	Electrical Characteristics	19
5.4.1	Voltage Supply	19
5.4.2	Logic Input and Output	20
5.4.3	Gate Driver	21
5.4.4	Active Miller Clamp	21
5.4.5	Short Circuit Clamping	22
5.4.6	Dynamic Characteristics	22
5.4.7	Desaturation Protection	23
5.4.8	Active Shut Down	24
6	Timing Diagrams	25
7	Package Outlines	27

List of Figures

Figure 1	Typical Application	8
Figure 2	Block Diagram 2ED020I12-F2	9
Figure 3	PG-DSO-36-58 (top view).	11
Figure 4	Application Example Bipolar Supply	13
Figure 5	Application Example Unipolar Supply	14
Figure 6	Propagation Delay, Rise and Fall Time	25
Figure 7	Typical Switching Behavior.	25
Figure 8	DESAT Switch-Off Behavior.	26
Figure 9	UVLO Behavior.	26
Figure 10	PG-DSO-36-58 (Plastic (Green) Dual Small Outline Package)	27

List of Tables

Table 1	Pin Configuration	10
Table 2	Absolute Maximum Ratings	16
Table 3	Operating Parameters	18
Table 4	Recommended Operating Parameters	18
Table 5	Voltage Supply	19
Table 6	Logic Input and Output	20
Table 7	Gate Driver	21
Table 8	Active Miller Clamp	21
Table 9	Short Circuit Clamping	22
Table 10	Dynamic Characteristics	22
Table 11	Desaturation Protection	23
Table 12	Active Shut Down	24

1 Overview

Main Features

- Dual channel isolated IGBT Driver
- For 600V/1200 V IGBTs
- 2 A rail-to-rail output
- Vcesat-detection
- Active Miller Clamp

Product Highlights

- Coreless transformer isolated driver
- Galvanic Insulation
- Integrated protection features
- Small footprint
- Suitable for operation at high ambient temperature

Typical Application

- AC and Brushless DC Motor Drives
- High Voltage DC/DC-Converter
- UPS-Systems
- Welding

Description

The 2ED020I12-F2 is a galvanic isolated dual channel IGBT driver in PG-DSO-36-58 package that provides two fully independent driver outputs with a current capability of typically 2A.

All logic pins are 5V CMOS compatible and could be directly connected to a microcontroller.

The data transfer across galvanic isolation is realized by the integrated Coreless Transformer Technology.

The 2ED020I12-F2 provides several protection features like IGBT desaturation protection, active Miller clamping and active shut down.



Product Name	Gate Drive Current	Package
2ED020I12-F2	±2 A	PG-DSO-36-58

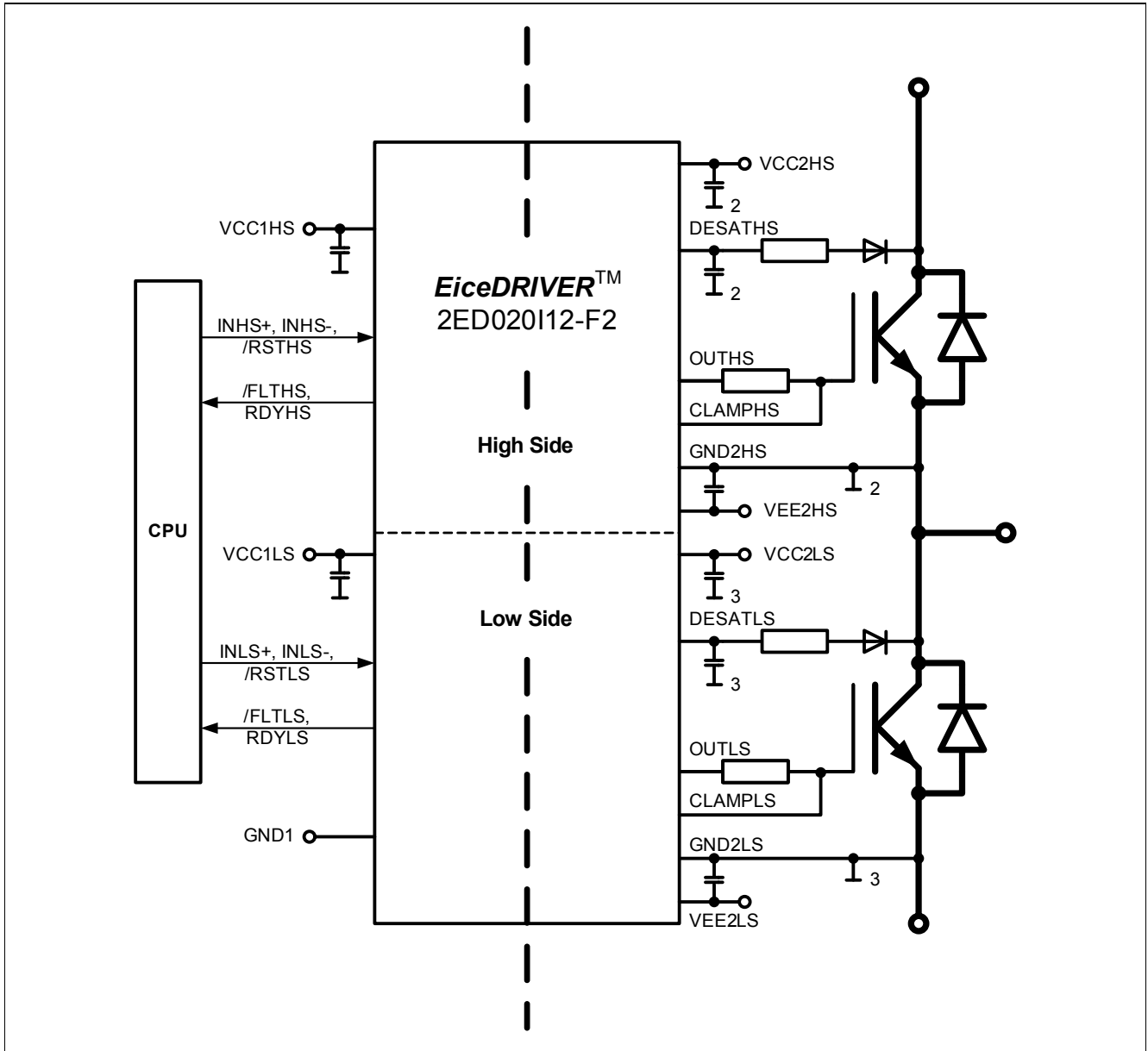

Figure 1 Typical Application

2 Block Diagram

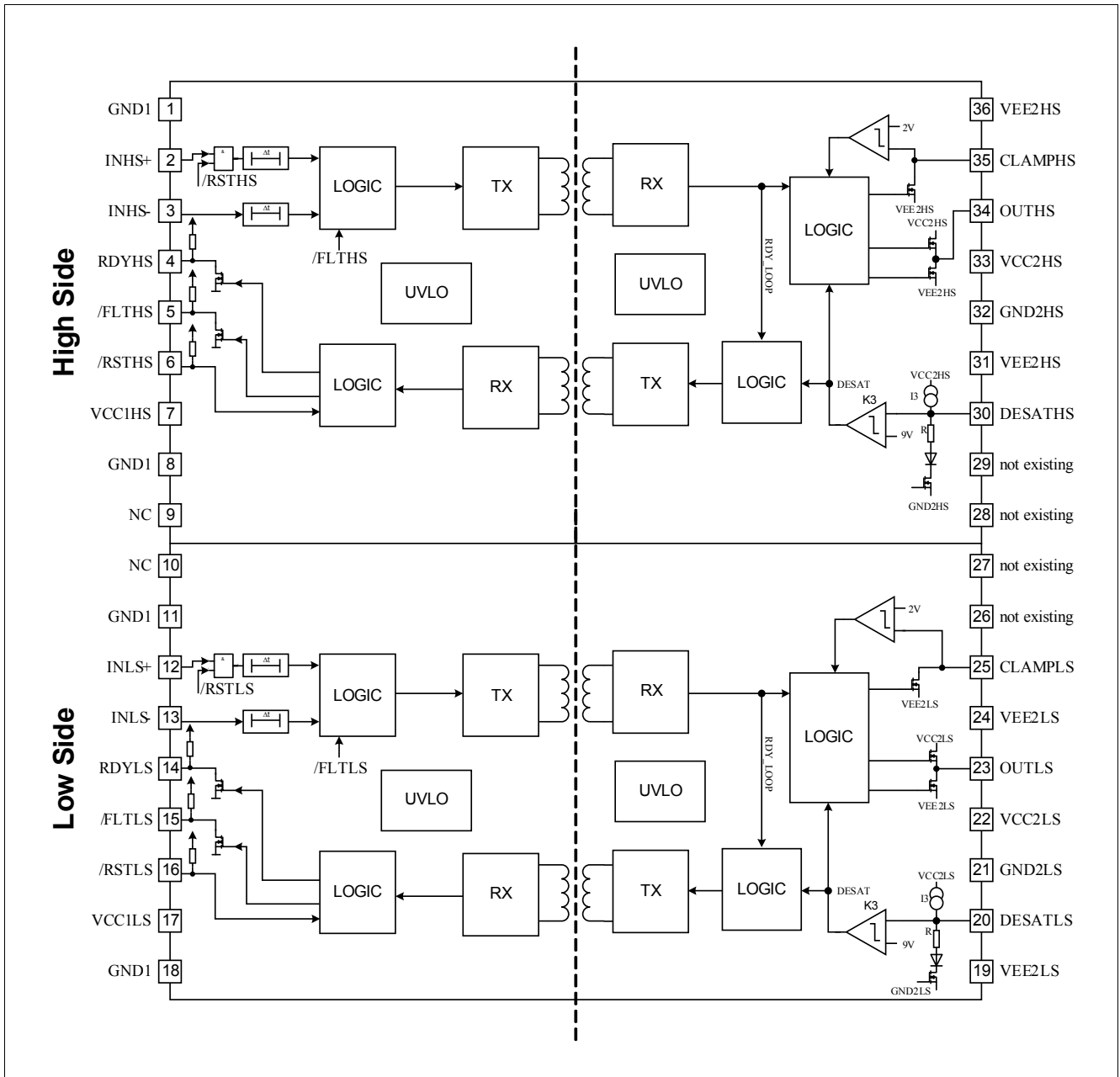

Figure 2 Block Diagram 2ED020112-F2

3 Pin Configuration and Functionality

3.1 Pin Configuration

Remark: xxxHS and xxxLS at the end of pin name only indicate an order for description, both drivers are isolated and could be used as high side or low side without any preference.

Table 1 Pin Configuration

Pin No.	Name	Function
1	GND1	Common ground input side
2	INHS+	Non inverted driver input high side
3	INHS-	Inverted driver input high side
4	RDYHS	Ready output high side
5	/FLTHS	Inverted fault output high side
6	/RSTHS	Inverted reset input high side
7	VCC1HS	Positive power supply input high side
8	GND1	Common ground input side
9	NC	Not used, internally connected to Pin 10
10	NC	Not used, internally connected to Pin 9
11	GND1	Common ground input side
12	INLS+	Non inverted driver input low side
13	INLS-	Inverted driver input lowside
14	RDYLS	Ready output low side
15	/FLTLS	Inverted fault output low side
16	/RSTLS	Inverted reset input low side
17	VCC1LS	Positive power supply input low side
18	GND1	Common ground input side
19	VEE2LS	Negative power supply low side driver
20	DESATLS	Desaturation protection low side driver
21	GND2LS	Signal ground low side driver
22	VCC2LS	Power supply low side driver
23	OUTLS	Output low side driver
24	VEE2LS	Negative power supply low side driver
25	CLAMPLS	Miller clamping low side driver
26		Pin not existing, cut out
27		Pin not existing, cut out
28		Pin not existing, cut out
29		Pin not existing, cut out
30	DESATHS	Desaturation protection high side driver
31	VEE2HS	Negative power supply high side driver

Table 1 Pin Configuration (cont'd)

Pin No.	Name	Function
32	GND2HS	Signal ground high side driver
33	VCC2HS	Power supply high side driver
34	OUTHHS	Output high side driver
35	CLAMPHS	Miller clamping high side driver
36	VEE2HS	Negative power supply high side driver

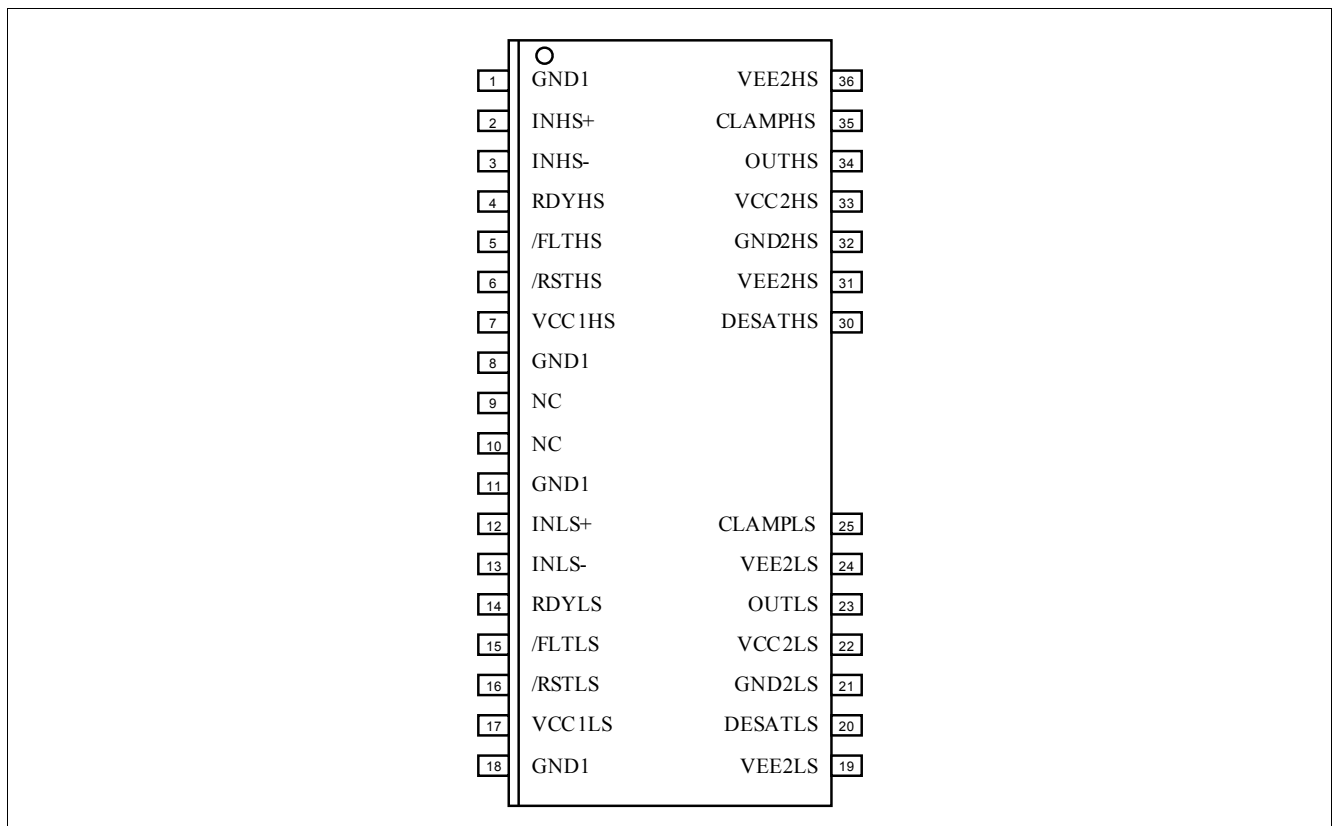

Figure 3 PG-DSO-36-58 (top view)

3.2 Pin Functionality

Remark: xxxHS and xxxLS at the end of pin name only indicate an order for description, both drivers are isolated and could be used as high side or low side without any preference.

GND1

Common ground connection of the input side.

INHS+, INLS+ Non Inverting Driver Input

INxx+ control signal for the driver output if INxx- is set to low (The IGBT is on if INxx+ = high and INxx- = low).

A minimum pulse width is defined to make the IC robust against glitches at IN+. An internal pull-down-resistor ensures IGBT off-state.

INHS–, INLS– Inverting Driver Input

INxx- control signal for driver output if INxx+ is set to high (IGBT is on if INxx– = low and INxx+ = high).

A minimum pulse width is defined to make the IC robust against glitches at INxx–. An internal pull-up-resistor ensures IGBT off-state.

/RSTHS, /RSTLS Reset Input

Function 1: Enable/shutdown of the input chip (The IGBT is off if /RSTxx = low). A minimum pulse width is defined to make the IC robust against glitches at /RSTxx.

Function 2: Resets the DESAT-FAULT-state of the chip if /RSTxx is low for a time T_{RST} . An internal pull-up-resistor is used to ensure /FLTxx status output.

/FLTHS, /FLTLS Fault Output

Open-drain output to report a desaturation error of the IGBT (/FLTxx is low if desaturation occurs).

RDYHS, RDYLS Ready Status Output

Open-drain output to report the correct operation of the device (RDYxx = high if both chips are above the UVLO level and the internal chip transmission is faultless).

VCC1HS, VCC1LS Positive Supply

5 V power supply of the input chip

VEE2HS, VEE2LS Negative Supply

Negative power supply pins of the output chip. If no negative supply voltage is available, both pins have to be connected to GND2xx.

DESATHS, DESATLS Desaturation Detection Input

Monitoring of the IGBT saturation voltage (V_{CE}) to detect desaturation caused by short circuits. If OUT is high, V_{CE} is above a defined value and a certain blanking time has expired, the desaturation protection is activated and the IGBT is switched off. The blanking time is adjustable by an external capacitor.

CLAMPHS, CLAMPLS Miller Clamping

Ties the gate voltage to ground after the IGBT has been switched off at a defined voltage to avoid a parasitic switch-on of the IGBT. During turn-off, the gate voltage is monitored and the clamp output is activated when the gate voltage goes 2 V below VEE2xx.

GND2HS, GND2LS Reference Ground

Reference ground of the output chip.

OUTHs, OUTLS Driver Output

Output pin to drive an IGBT. The voltage is switched between VEE2xx and VCC2xx. In normal operating mode Vout is controlled by INxx+, INxx- and /RSTxx. During error mode (UVLO, internal error or DESATxx Vout is set to VEE2xx independent of the input control signals.

VCC2HS, VCC2LS Positive Supply

Positive power supply pin of the output side.

4 Functional Description

4.1 Introduction

The 2ED020112-F2 is an advanced IGBT dual gate driver that can be also used for driving power MOS devices. Control and protection functions are included to make possible the design of high reliability systems.

The device consists of two galvanic separated driver. The input can be directly connected to a standard 5 V DSP or microcontroller with CMOS in/output and the output driver are connected to the high side and low side switch.

The rail-to-rail driver outputs enables the user to provide easy clamping of the IGBTs gate voltage during short circuit of the IGBT. So an increase of short circuit current due to the feedback via the Miller capacitance can be avoided. Further, a rail-to-rail output reduces power dissipation.

The device also includes IGBT desaturation protection with FAULT status outputs.

Two READY status outputs reports if the device is supplied and operates correctly.

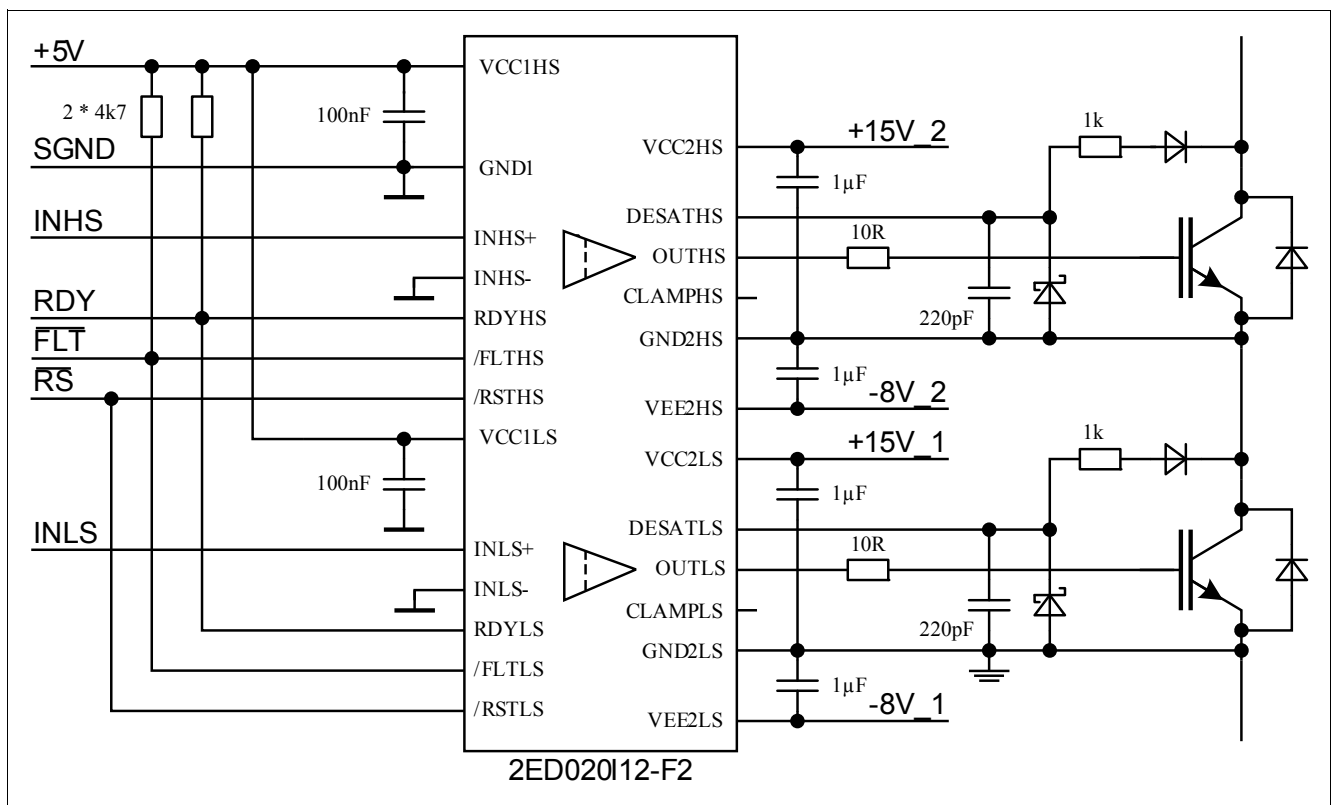

Figure 4 Application Example Bipolar Supply

4.2 Supply

The driver 2ED020112-F2 is designed to support two different supply configurations, bipolar supply and unipolar supply.

In bipolar supply the driver is typically supplied with a positive voltage of 15V at VCC2 and a negative voltage of -8V at VEE2, please refer to [Figure 4](#). Negative supply prevents a dynamic turn on due to the additional charge which is generated from IGBT input capacitance times negative supply voltage. If an appropriate negative supply voltage is used, connecting CLAMPxx to IGBT gate is redundant and therefore typically not necessary.

Functional Description Internal Protection Features

For unipolar supply configuration the driver is typically supplied with a positive voltage of 15V at VCC2. Erratically dynamic turn on of the IGBT could be prevented with active Miller clamp function, so CLAMP output is directly connected to IGBT gate, please refer to [Figure 5](#).

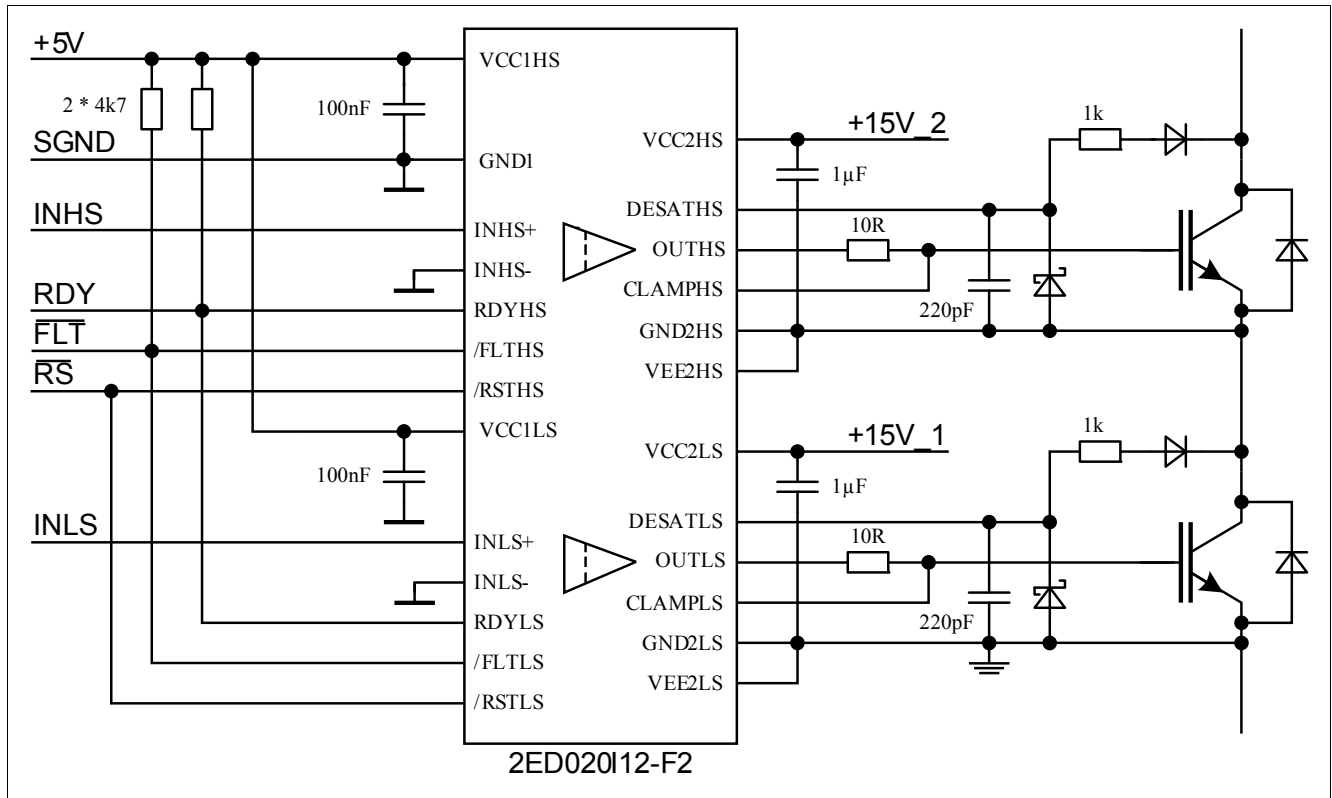

Figure 5 Application Example Unipolar Supply

4.3 Internal Protection Features

4.3.1 Undervoltage Lockout (UVLO)

To ensure correct switching of IGBTs the device is equipped with undervoltage lockout for all driver outputs as well as for input section, please see [Figure 9](#).

If the power supply voltage V_{VCC1xx} of the input section drops below V_{UVLOL1} a turn-off signal is sent to the output driver before power-down. The IGBT is switched off and the signals at INxx+ and INxx- are ignored as long as V_{VCC1xx} reaches the power-up voltage V_{UVLOH1} .

If the power supply voltage V_{VCC2xx} of the output driver goes down below V_{UVLOL2} the IGBT is switched off and signals from the input chip are ignored as long as V_{VCC2xx} reaches the power-up voltage V_{UVLOH2} . VEE2xx is not monitored, otherwise negative supply voltage range from 0 V to -12 V would not be possible.

4.3.2 READY Status Output

The READY outputs shows the status of three internal protection features.

- UVLO of the input chip
- UVLO of the output chip after a short delay
- Internal signal transmission after a short delay

It is not necessary to reset the READY signal since its state only depends on the status of the former mentioned protection signals.

4.3.3 Watchdog Timer

During normal operation the internal signal transmission is monitored by a watchdog timer. If the transmission fails for a given time, the IGBT is switched off and the READY output reports an internal error.

4.3.4 Active Shut-Down

The Active Shut-Down feature ensures a safe IGBT off-state if the output chip is not connected to the power supply, IGBT gate is clamped at OUTxx to VEE2xx.

4.4 Non-Inverting and Inverting Inputs

There are two possible input modes to control the IGBT. At non-inverting mode INxx+ controls the driver output while INxx- is set to low. At inverting mode INxx- controls the driver output while INxx+ is set to high, please see [Figure 7](#). A minimum input pulse width is defined to filter occasional glitches.

4.5 Driver Outputs

The output driver sections uses only MOSFETs to provide a rail-to-rail output. This feature permits that tight control of gate voltage during on-state and short circuit can be maintained as long as the drivers supply is stable. Due to the low internal voltage drop, switching behaviour of the IGBT is predominantly governed by the gate resistor. Furthermore, it reduces the power to be dissipated by the driver.

4.6 External Protection Features

4.6.1 Desaturation Protection

A desaturation protection ensures the protection of the IGBT at short circuit. When the DESAT voltage goes up and reaches 9 V, the output is driven low. Further, the FAULT output is activated, please refer to [Figure 8](#). A programmable blanking time is used to allow enough time for IGBT saturation. Blanking time is provided by a highly precise internal current source and an external capacitor.

4.6.2 Active Miller Clamp

In a half bridge configuration the switched off IGBT tends to dynamically turn on during turn on phase of the opposite IGBT. A Miller clamp allows sinking the Miller current across a low impedance path in this high dV/dt situation. Therefore in many applications, the use of a negative supply voltage can be avoided.

During turn-off, the gate voltage is monitored and the clamp output is activated when the gate voltage goes below typical 2 V (related to VEE2). The clamp is designed for a Miller current up to 2 A.

4.6.3 Short Circuit Clamping

During short circuit the IGBTs gate voltage tends to rise because of the feedback via the Miller capacitance. An additional protection circuit connected to OUTxx and CLAMPxx limits this voltage to a value slightly higher than the supply voltage. A current of maximum 500 mA for 10 μ s may be fed back to the supply through one of this paths. If higher currents are expected or a tighter clamping is desired external Schottky diodes may be added.

4.7 RESET

The reset inputs have two functions.

Firstly, /RSTxx is in charge of setting back the FAULT output. If /RSTxx is low longer than a given time, /FLTxx will be cleared at the rising edge of /RSTxx; otherwise, it will remain unchanged. Moreover, it works as enable/shutdown of the input logic.

5 Electrical Parameters

5.1 Absolute Maximum Ratings

Note: Absolute maximum ratings are defined as ratings, which when being exceeded may lead to destruction of the integrated circuit. Unless otherwise noted all parameters refer to GND1. The specification for all driver signals is valid for HS and LS with out special notice, e.g. IN+ covers INHS+ as well as INLS+. The signals from driver output side are measured with respect to their specific GND2HS or GND2LS.

Table 2 Absolute Maximum Ratings

Parameter	Symbol	Values		Unit	Note / Test Condition
		Min.	Max.		
Positive power supply output side	V_{VCC2}	-0.3	20	V	1)
Negative power supply output side	V_{VEE2}	-12	0.3	V	1)
Maximum power supply voltage output side ($V_{VCC2} - V_{VEE2}$)	V_{max2}	–	28	V	–
Gate driver output	V_{OUT}	$V_{VEE2}-0.3$	$V_{max2}+0.3$	V	–
Gate driver high output maximum current	I_{OUT}	–	2.4	A	t = 2 μ s
Gate & Clamp driver low output maximum current	I_{OUT}	–	2.4	A	t = 2 μ s
Maximum short circuit clamping time	t_{CLP}	–	10	μ s	$I_{CLAMP/OUT} = 500$ mA
Positive power supply input side	V_{VCC1}	-0.3	6.5	V	–
Logic input voltages (IN+, IN-, RST)	$V_{LogicIN}$	-0.3	6.5	V	–
Opendrain Logic output voltage (FLT)	$V_{FLT\#}$	-0.3	6.5	V	–
Opendrain Logic output voltage (RDY)	V_{RDY}	-0.3	6.5	V	–
Opendrain Logic output current (FLT)	$I_{FLT\#}$	–	10	mA	–
Opendrain Logic output current (RDY)	I_{RDY}	–	10	mA	–
Pin DESAT voltage	V_{DESAT}	-0.3	$V_{VCC2} + 0.3$	V	1)
Pin CLAMP voltage	V_{CLAMP}	-0.3	$V_{VCC2} + 0.3^{2)}$	°C	3)–
Input to output isolation voltage (GND2)	V_{ISO}	-1200	1200	V	
Output to output isolation voltage (GND2HS vs GND2LS)	V_{ISO_OUT}	-1200	1200	V	1)
Junction temperature	T_J	-40	150	°C	–
Storage temperature	T_S	-55	150	°C	–
Power dissipation, per input part	$P_{D, IN}$	–	100	mW	4) @ $T_A = 25^\circ\text{C}$
Power dissipation, per output part	$P_{D, OUT}$	–	400	mW	4) @ $T_A = 25^\circ\text{C}$
Power dissipation, total	$P_{D, tot}$	–	1000	mW	4) @ $T_A = 25^\circ\text{C}$

Electrical Parameters Absolute Maximum Ratings
Table 2 Absolute Maximum Ratings (cont'd)

Parameter	Symbol	Values		Unit	Note / Test Condition
		Min.	Max.		
Thermal resistance (Input part)	$R_{THJA,IN}$	–	375	K/W	4) @ $T_A = 25^\circ\text{C}$, $P_{D, IN_HS+LS} = 200\text{ mW}$, $P_{D, OUT_HS+LS} = 800\text{ mW}$
Thermal resistance (Output part)	$R_{THJA,OUT}$	–	110	K/W	4) @ $T_A = 25^\circ\text{C}$, $P_{D, IN_HS+LS} = 200\text{ mW}$, $P_{D, OUT_HS+LS} = 800\text{ mW}$
ESD Capability	V_{ESD}	–	1	kV	Human Body Model ⁵⁾

1) With respect to GND2.

2) May be exceeded during short circuit clamping.

3) With respect to VEE2.

4) IC power dissipation is derated linearly at 11.8 mW/°C above 65°C. Thermal performance may change significantly with layout and heat dissipation of components in close proximity.

5) According to EIA/JESD22-A114-B (discharging a 100 pF capacitor through a 1.5 kΩ series resistor).

5.2 Operating Parameters

Note: Within the operating range the IC operates as described in the functional description. Unless otherwise noted all parameters refer to GND1. The specification for all driver signals is valid for HS and LS with out special notic, e.g. IN+ covers INHS+ as well as INLS+. The signals from driver output side are measured with respect to their specific GND2HS or GND2LS.

Table 3 Operating Parameters

Parameter	Symbol	Values		Unit	Note / Test Condition
		Min.	Max.		
Positive power supply output side	V_{VCC2}	13	20	V	1)
Negative power supply output side	V_{VEE2}	-12	0	V	1)
Maximum power supply voltage output side ($V_{VCC2} - V_{VEE2}$)	V_{max2}	–	28	V	–
Positive power supply input side	V_{VCC1}	4.5	5.5	V	–
Logic input voltages (IN+, IN-, RST)	$V_{LogicIN}$	-0.3	5.5	V	–
Pin CLAMP voltage	V_{CLAMP}	$V_{VEE2} - 0.3$	$V_{VCC2}^{2)}$	V	–
Pin DESAT voltage	V_{DESAT}	-0.3	V_{VCC2}	V	1)
Pin TLSET voltage	V_{TLSET}	-0.3	V_{VCC2}	V	1)
Ambient temperature	T_A	-40	125	°C	–
Common mode transient immunity ³⁾	$ dV_{ISO}/dt $	–	50	kV/μs	@ 500 V

1) With respect to GND2.

2) May be exceeded during short circuit clamping.

3) The parameter is not subject to production test - verified by design/characterization

5.3 Recommended Operating Parameters

Note: Unless otherwise noted all parameters refer to GND1. The specification for all driver signals is valid for HS and LS with out special notic, e.g. IN+ covers INHS+ as well as INLS+. The signals from driver output side are measured with respect to their specific GND2HS or GND2LS.

Table 4 Recommended Operating Parameters

Parameter	Symbol	Value	Unit	Note / Test Condition
Positive power supply output side	V_{VCC2}	15	V	1)
Negative power supply output side	V_{VEE2}	-8	V	1)
Positive power supply input side	V_{VCC1}	5	V	–

1) With respect to GND2.

5.4 Electrical Characteristics

Note: The electrical characteristics involve the spread of values for the supply voltages, load and junction temperatures given below. Typical values represent the median values, which are related to production processes at $T = 25^{\circ}\text{C}$. Unless otherwise noted all voltages are given with respect to GND. The specification for all driver signals is valid for HS and LS with out special notice, e.g. IN+ covers INHS+ as well as INLS+. The signals from driver output side are measured with respect to their specific GND2HS or GND2LS.

5.4.1 Voltage Supply

Table 5 Voltage Supply

Parameter	Symbol	Values			Unit	Note / Test Condition
		Min.	Typ.	Max.		
UVLO Threshold Input Chip	V_{UVLOH1}	–	4.1	4.3	V	–
	V_{UVLOL1}	3.5	3.8	–	V	–
UVLO Hysteresis Input Chip ($V_{UVLOH1} - V_{UVLOL1}$)	V_{HYS1}	0.15	–	–	V	–
UVLO Threshold Output Chip	V_{UVLOH2}	–	12.0	12.6	V	–
	V_{UVLOL2}	10.4	11.0	–	V	–
UVLO Hysteresis Output Chip ($V_{UVLOH1} - V_{UVLOL1}$)	V_{HYS2}	0.7	0.9	–	V	–
Quiescent Current Input Chip	I_{Q1}	–	7	9	mA	$V_{VCC1} = 5\text{ V}$ IN+ = High, IN- = Low =>OUT = High, RDY = High, /FLT = High
Quiescent Current Output Chip	I_{Q2}	–	4	6	mA	$V_{VCC2} = 15\text{ V}$ $V_{VEE2} = -8\text{ V}$ IN+ = High, IN- = Low =>OUT = High, RDY = High, /FLT = High

5.4.2 Logic Input and Output
Table 6 Logic Input and Output

Parameter	Symbol	Values			Unit	Note / Test Condition
		Min.	Typ.	Max.		
IN+,IN-, $\overline{\text{RST}}$ Low Input Voltage	$V_{\text{IN+L}}$, $V_{\text{IN-L}}$, $V_{\text{RSTL\#}}$	–	–	1.5	V	–
IN+,IN-, $\overline{\text{RST}}$ High Input Voltage	$V_{\text{IN+H}}$, $V_{\text{IN-H}}$, $V_{\text{RSTH\#}}$	3.5	–	–	V	–
IN-, $\overline{\text{RST}}$ Input Current	$I_{\text{IN-}}$, $I_{\text{RST\#}}$	-400	-100	–	μA	$V_{\text{IN-}} = \text{GND1}$ $V_{\text{RST\#}} = \text{GND1}$
IN+ Input Current	$I_{\text{IN+}}$	–	100	400	μA	$V_{\text{IN+}} = \text{VCC1}$
RDY, $\overline{\text{FLT}}$ Pull Up Current	I_{PRDY} , $I_{\text{PFLT\#}}$	-400	-100	–	μA	$V_{\text{RDY}} = \text{GND1}$ $V_{\text{FLT\#}} = \text{GND1}$
Input Pulse Suppression IN+, IN-	$T_{\text{MININ+}}$, $T_{\text{MININ-}}$	30	40	–	ns	–
Input Pulse Suppression $\overline{\text{RST}}$ for ENABLE/SHUTDOWN	T_{MINRST}	30	40	–	ns	–
Pulse Width $\overline{\text{RST}}$ for Reseting FLT	T_{RST}	800	–	–	ns	–
$\overline{\text{FLT}}$ Low Voltage	V_{FLTL}	–	–	300	mV	$I_{\text{SINK(FLT\#)}} = 5 \text{ mA}$
RDY Low Voltage	V_{RDYL}	–	–	300	mV	$I_{\text{SINK(RDY)}} = 5 \text{ mA}$

5.4.3 Gate Driver

Table 7 Gate Driver

Parameter	Symbol	Values			Unit	Note / Test Condition
		Min.	Typ.	Max.		
High Level Output Voltage	V_{OUTH1}	$V_{\text{CC2}} - 1.2$	$V_{\text{CC2}} - 0.8$	–	V	$I_{\text{OUTH}} = -20 \text{ mA}$
	V_{OUTH2}	$V_{\text{CC2}} - 2.5$	$V_{\text{CC2}} - 2.0$	–	V	$I_{\text{OUTH}} = -200 \text{ mA}$
	V_{OUTH3}	$V_{\text{CC2}} - 9$	$V_{\text{CC2}} - 5$	–	V	$I_{\text{OUTH}} = -1 \text{ A}$
	V_{OUTH4}		$V_{\text{CC2}} - 10$	–	V	$I_{\text{OUTH}} = -2 \text{ A}$
High Level Output Peak Current	I_{OUTH}	-1.5	-2.0	–	A	IN+ = High, IN- = Low; OUT = High
Low Level Output Voltage	V_{OUTL1}	–	$V_{\text{VEE2}} + 0.04$	$V_{\text{VEE2}} + 0.09$	V	$I_{\text{OUTL}} = 20 \text{ mA}$
	V_{OUTL2}	–	$V_{\text{VEE2}} + 0.3$	$V_{\text{VEE2}} + 0.85$	V	$I_{\text{OUTL}} = 200 \text{ mA}$
	V_{OUTL3}	–	$V_{\text{VEE2}} + 2.1$	$V_{\text{VEE2}} + 5$	V	$I_{\text{OUTL}} = 1 \text{ A}$
	V_{OUTL4}	–	$V_{\text{VEE2}} + 7$	–	V	$I_{\text{OUTL}} = 2 \text{ A}$
Low Level Output Peak Current	I_{OUTL}	1.5	2.0	–	A	IN+ = Low, IN- = Low; OUT = Low, $V_{\text{VCC2}} = 15 \text{ V}$, $V_{\text{VEE2}} = -8 \text{ V}$

5.4.4 Active Miller Clamp

Table 8 Active Miller Clamp

Parameter	Symbol	Values			Unit	Note / Test Condition
		Min.	Typ.	Max.		
Low Level Clamp Voltage	V_{CLAMPL1}	–	$V_{\text{VEE2}} + 0.03$	$V_{\text{VEE2}} + 0.08$	V	$I_{\text{OUTL}} = 20 \text{ mA}$
	V_{CLAMPL2}	–	$V_{\text{VEE2}} + 0.3$	$V_{\text{VEE2}} + 0.8$	V	$I_{\text{OUTL}} = 200 \text{ mA}$
	V_{CLAMPL3}	–	$V_{\text{VEE2}} + 1.9$	$V_{\text{VEE2}} + 4.8$	V	$I_{\text{OUTL}} = 1 \text{ A}$
Low Level Clamp Current	I_{CLAMPL}	2	–	–	A	¹⁾
Clamp Threshold Voltage	V_{CLAMP}	1.6	2.1	2.4	V	Related to VEE2

1) The parameter is not subject to production test - verified by design/characterization

5.4.5 Short Circuit Clamping

Table 9 Short Circuit Clamping

Parameter	Symbol	Values			Unit	Note / Test Condition
		Min.	Typ.	Max.		
Clamping voltage (OUT) ($V_{OUT} - V_{VCC2}$)	V_{CLPout}	–	0.8	1.3	V	IN+ = High, IN- = Low, OUT = High $I_{OUT} = 500$ mA pulse test, $t_{CLPmax} = 10$ μ s)
Clamping voltage (CLAMP) ($V_{VCLAMP} - V_{VCC2}$)	$V_{CLPclamp}$	–	1.3	–	V	IN+ = High, IN- = Low, OUT = High $I_{CLAMP} = 500$ mA (pulse test, $t_{CLPmax} = 10$ μ s)
Clamping voltage (CLAMP)	$V_{CLPclamp}$	–	0.7	1.1	V	IN+ = High, IN- = Low, OUT = High $I_{CLAMP} = 20$ mA

5.4.6 Dynamic Characteristics

Dynamic characteristics are measured with $V_{VCC1} = 5$ V, $V_{VCC2} = 15$ V and $V_{VEE2} = -8$ V.

Table 10 Dynamic Characteristics

Parameter	Symbol	Values			Unit	Note / Test Condition
		Min.	Typ.	Max.		
IN+, IN- input to output propa-gation delay ON	T_{PDON}	145	170	195	ns	$C_{LOAD} = 100$ pF $V_{IN+} = 50\%$, $V_{OUT} = 50\%$ @ 25°C
IN+, IN- input to output propa-gation delay OFF	T_{PDOFF}	145	165	190	ns	
IN+, IN- input to output propa-gation delay distortion ($T_{PDOFF} - T_{PDON}$)	T_{PDISTO}	-35	-5	25	ns	
IN+, IN- input to output propagation delay ON variation due to temp	T_{PDONT}	–	–	25	ns	¹⁾ $C_{LOAD} = 100$ pF $V_{IN+} = 50\%$, $V_{OUT} = 50\%$
IN+, IN- input to output propagation delay OFF variation due to temp	T_{PDOFFt}	–	–	40	ns	¹⁾ $C_{LOAD} = 100$ pF $V_{IN+} = 50\%$, $V_{OUT} = 50\%$
IN+, IN- input to output propagation delay distortion variation due to temp ($T_{PDOFF} - T_{PDON}$)	$T_{PDISTOt}$	–	–	20	ns	¹⁾ $C_{LOAD} = 100$ pF $V_{IN+} = 50\%$, $V_{OUT} = 50\%$

Table 10 Dynamic Characteristics (cont'd)

Parameter	Symbol	Values			Unit	Note / Test Condition
		Min.	Typ.	Max.		
Rise Time	T_{RISE}	10	30	60	ns	$C_{LOAD} = 1 \text{ nF}$ $V_L 10\%, V_H 90\%$
		200	400	800	ns	$C_{LOAD} = 34 \text{ nF}$ $V_L 10\%, V_H 90\%$
Fall Time	T_{FALL}	10	50	90	ns	$C_{LOAD} = 1 \text{ nF}$ $V_L 10\%, V_H 90\%$
		200	350	600	ns	$C_{LOAD} = 34 \text{ nF}$ $V_L 10\%, V_H 90\%$

1) The parameter is not subject to production test - verified by design/characterization

5.4.7 Desaturation Protection

Table 11 Desaturation Protection

Parameter	Symbol	Values			Unit	Note / Test Condition
		Min.	Typ.	Max.		
Blanking Capacitor Charge Current	I_{DESATC}	450	500	550	μA	$V_{VCC2} = 15 \text{ V}$, $V_{VEE2} = -8 \text{ V}$ $V_{DESAT} = 2 \text{ V}$
Blanking Capacitor Discharge Current	I_{DESATD}	9	14	–	mA	$V_{VCC2} = 15 \text{ V}$, $V_{VEE2} = -8 \text{ V}$ $V_{DESAT} = 6 \text{ V}$
Desaturation Reference Level	V_{DESAT}	8.3	9	9.5	V	$V_{VCC2} = 15 \text{ V}$
Desaturation Filter Time	$T_{DESATfilter}$	–	250	–	ns	$V_{VCC2} = 15 \text{ V}$, $V_{VEE2} = -8 \text{ V}$ $V_{DESAT} = 9 \text{ V}$
Desaturation Sense to OUT Low Delay	$T_{DESATOUT}$	–	350	430	ns	$V_{OUT} = 90\%$ $C_{LOAD} = 1 \text{ nF}$
Desaturation Sense to FLT Low Delay	$T_{DESATFLT}$	–	–	2.25	μs	$V_{FLT\#} = 10\%$; $I_{FLT\#} = 5 \text{ mA}$
Desaturation Low Voltage	V_{DESATL}	0.4	0.6	0.95	V	IN+ = Low, IN- = Low, OUT = Low
Leading edge blanking	$T_{DESATleb}$	–	400	–	ns	Not subject of production test

5.4.8 Active Shut Down

Table 12 Active Shut Down

Parameter	Symbol	Values			Unit	Note / Test Condition
		Min.	Typ.	Max.		
Active Shut Down Voltage	$V_{ACTSD}^{1)}$	–	–	2.0	V	$I_{OUT} = -200 \text{ mA}$, V_{CC2} open

1) With reference to VEE2

6 Timing Diagrams

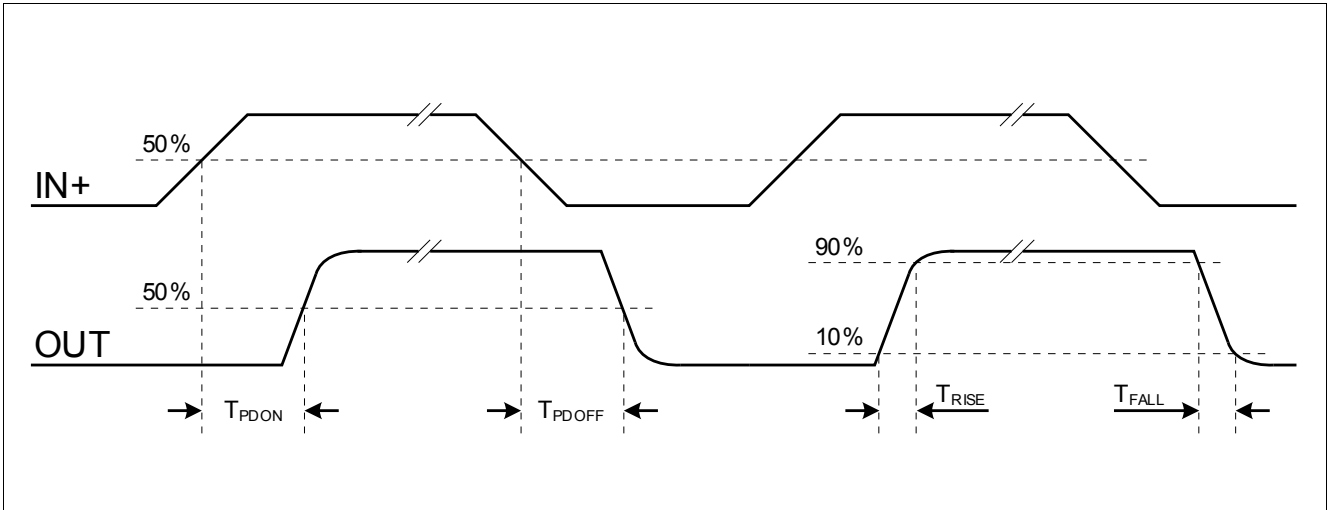

Figure 6 Propagation Delay, Rise and Fall Time

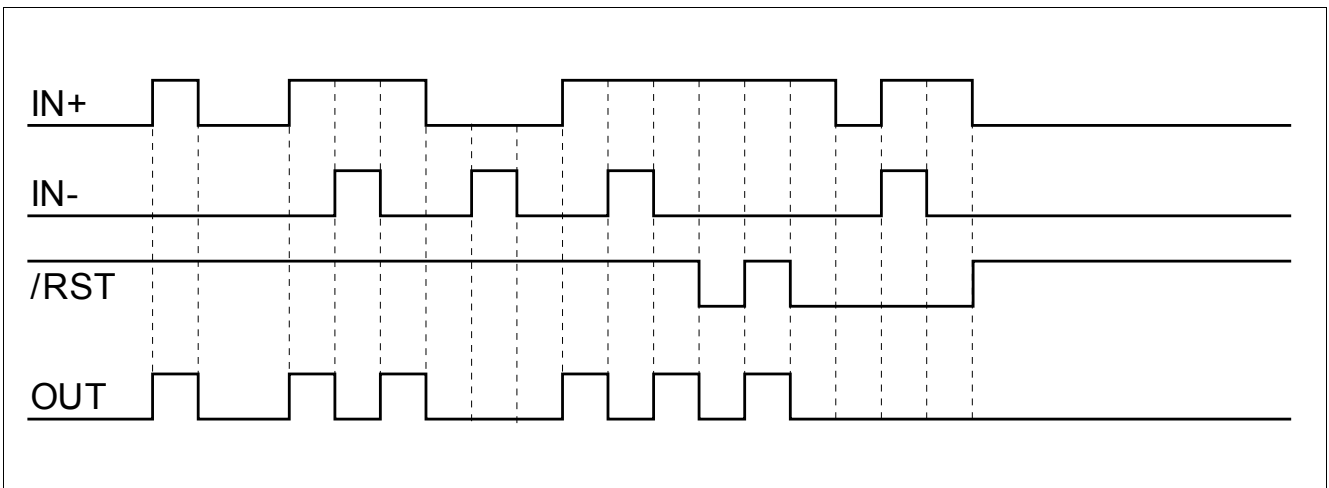

Figure 7 Typical Switching Behavior

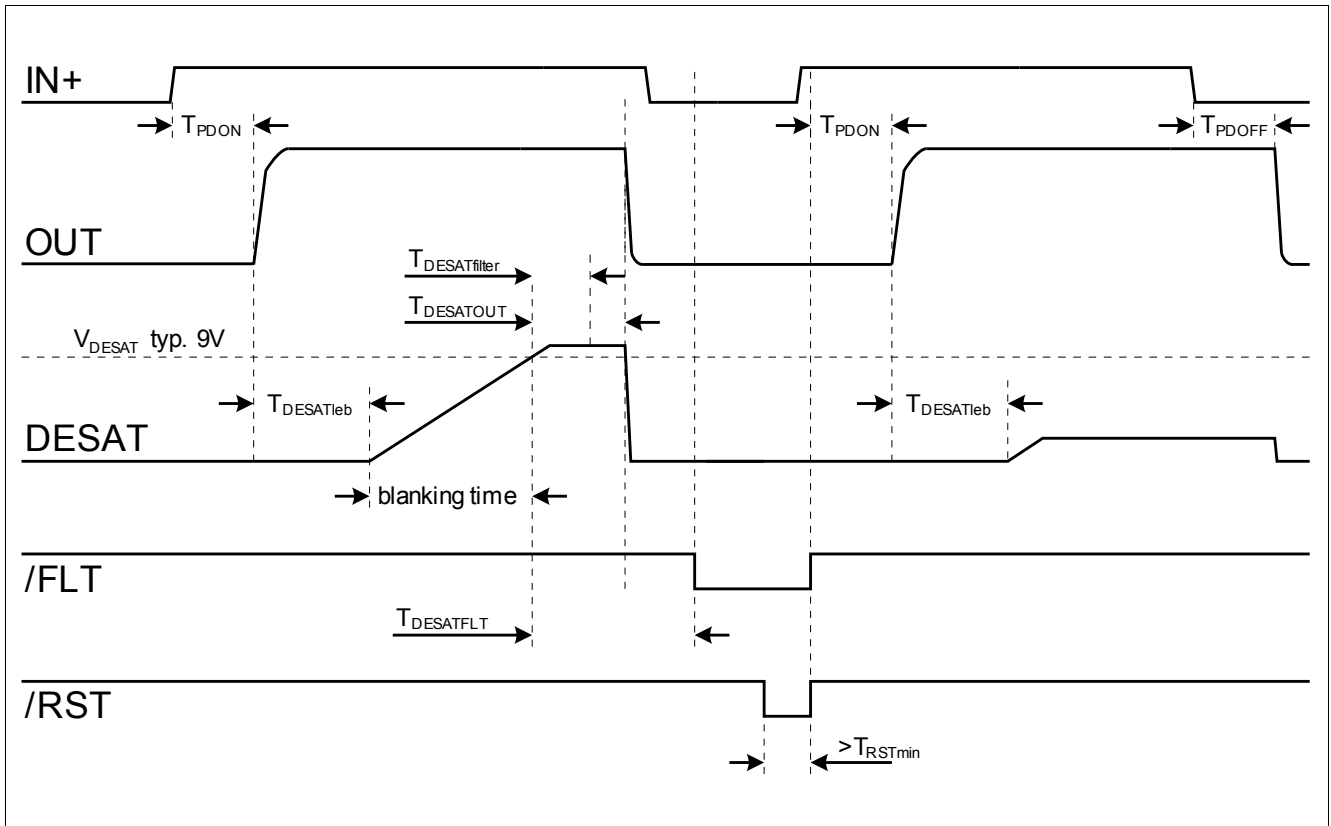

Figure 8 DESAT Switch-Off Behavior

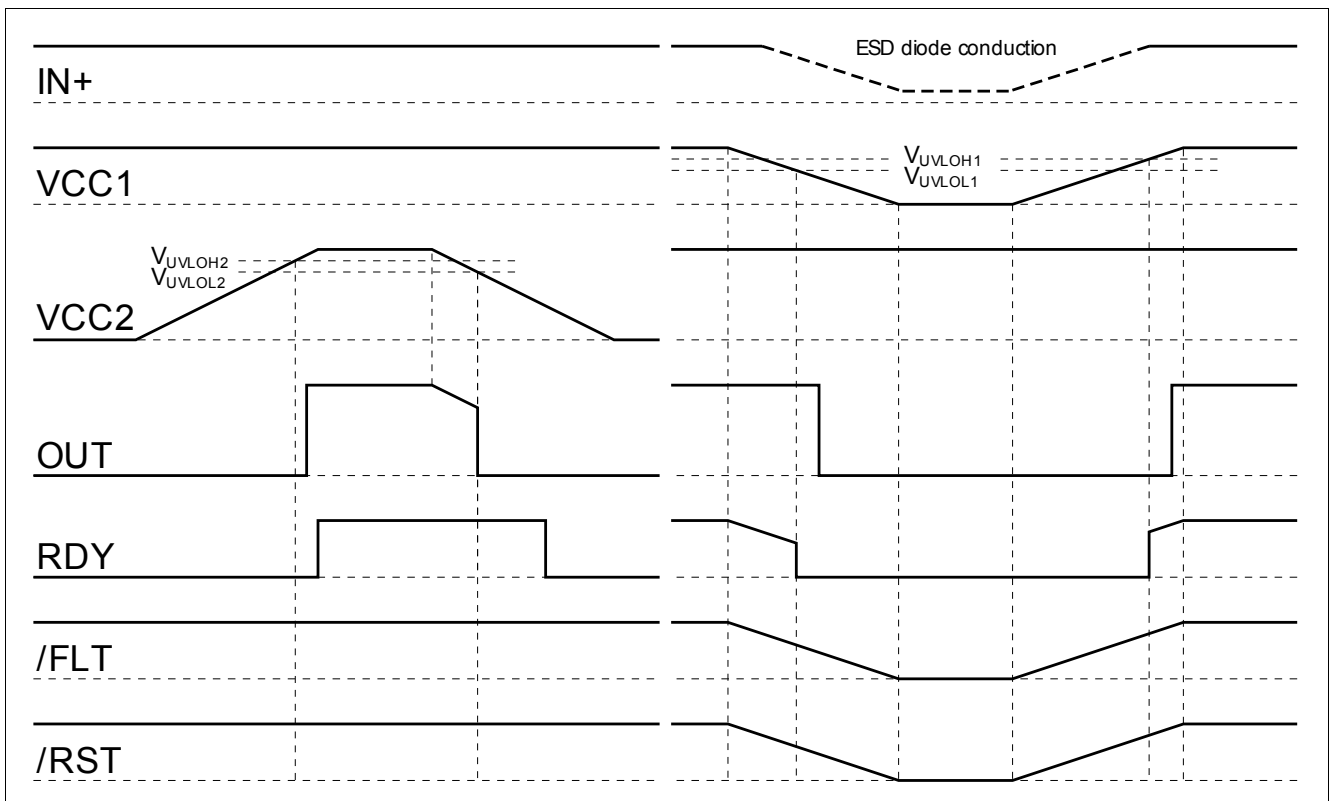

Figure 9 UVLO Behavior

7 Package Outlines

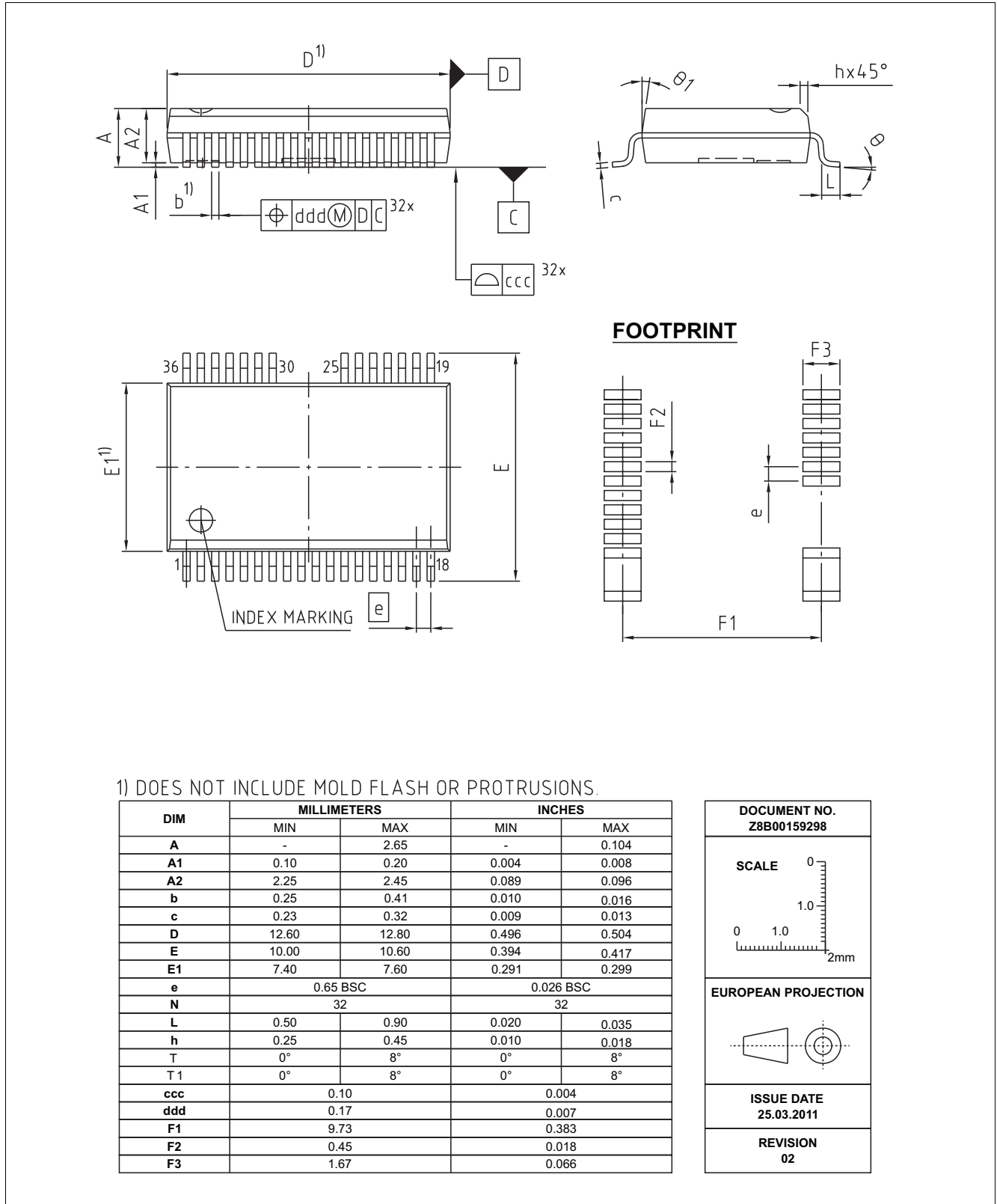



Figure 10 PG-DSO-36-58 (Plastic (Green) Dual Small Outline Package)

www.infineon.com

Published by Infineon Technologies AG

Looking for pricing, stock, or lifecycle information?

Click below to explore more details on WIN SOURCE:

-  [View 2ED020I12F2XUMA1 on WIN SOURCE](#)
-  [Infineon Technologies Information](#)

Optimize Your Supply Chain with WIN SOURCE Solutions

-  Global Sourcing Solution
-  Obsolete Management
-  Cost Control Management
-  Shortage Management
-  Alternative Solution
-  Excess Inventory Management