



**THE DATASHEET OF
1812CC101KAT1A\SB**



High Voltage MLC Chips

For 600V to 5000V Applications

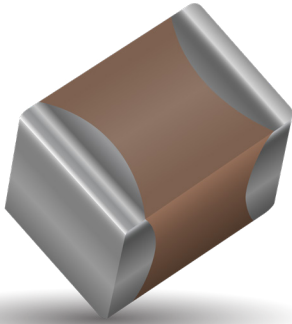

NEW 630V RANGE

High value, low leakage and small size are difficult parameters to obtain in capacitors for high voltage systems. AVX special high voltage MLC chip capacitors meet these performance characteristics and are designed for applications such as snubbers in high frequency power converters, resonators in SMPS, and high voltage coupling/dc blocking. These high voltage chip designs exhibit low ESRs at high frequencies.

Larger physical sizes than normally encountered chips are used to make high voltage MLC chip products. Special precautions must be taken in applying these chips in surface mount assemblies. The temperature gradient during heating or cooling cycles should not exceed 4°C per second. The preheat temperature must be within 50°C of the peak temperature reached by the ceramic bodies through the soldering process. Chip sizes 1210 and larger should be reflow soldered only. Capacitors may require protective surface coating to prevent external arcing.

For 1825, 2225 and 3640 sizes, AVX offers leaded version in either thru-hole or SMT configurations (for details see section on high voltage leaded MLC chips).

HOW TO ORDER

1808	A	A	271	K	A	1	2	A
AVX Style	Voltage	Temperature Coefficient	Capacitance Code (2 significant digits + no. of zeros) Examples:	Capacitance Tolerance C0G: J = ±5% K = ±10% M = ±20% X7R: K = ±10% M = ±20% Z = +80%, -20%	Test Level A = Standard	Termination* 1 = Pd/Ag T = Plated Ni and Sn (RoHS Compliant)	Packaging 1 or 2 = 7" Reel** 3 or 4 = 13" Reel	Special Code A = Standard
0805	600V/630V = C	NPO (C0G) = A X7R = C	10 pF = 100 100 pF = 101 1,000 pF = 102 22,000 pF = 223 220,000 pF = 224 1 μF = 105					
1206	1000V = A							
1210	1500V = S							
1808	2000V = G							
1812	2500V = W							
1825	3000V = H							
2220	4000V = J							
2225	5000V = K							
3640								

*Note: Terminations with 5% minimum lead (Pb) is available, see pages 100 and 101 for LD style. Leaded terminations are available, see pages 102-106.

Notes: Capacitors with X7R dielectrics are not intended for applications across AC supply mains or AC line filtering with polarity reversal. Contact plant for recommendations. Contact factory for availability of Termination and Tolerance options for Specific Part Numbers.

**The 3640 Style is not available on 7" Reels.

*** AVX offers nonstandard chip sizes. Contact factory for details.

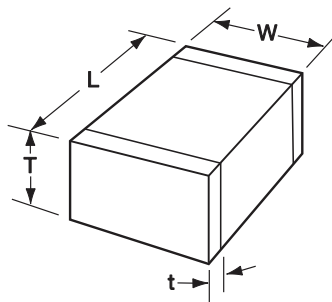

DIMENSIONS

millimeters (inches)

SIZE	0805	1206	1210*	1808*	1812*	1825*	2220*	2225*	3640*
(L) Length	2.10 ± 0.20 (0.083 ± 0.008)	3.30 ± 0.30 (0.130 ± 0.012)	3.30 ± 0.40 (0.130 ± 0.016)	4.60 ± 0.50 (0.181 ± 0.020)	4.60 ± 0.50 (0.181 ± 0.020)	4.60 ± 0.50 (0.181 ± 0.020)	5.70 ± 0.50 (0.224 ± 0.020)	5.72 ± 0.25 (0.225 ± 0.010)	9.14 ± 0.25 (0.360 ± 0.010)
(W) Width	1.25 ± 0.20 (0.049 ± 0.008)	1.60 ± 0.20 (0.063 ± 0.008)	2.50 ± 0.30 (0.098 ± 0.012)	2.00 ± 0.20 (0.079 ± 0.008)	3.20 ± 0.30 (0.126 ± 0.012)	6.30 ± 0.40 (0.248 ± 0.016)	5.00 ± 0.40 (0.197 ± 0.016)	6.35 ± 0.25 (0.250 ± 0.010)	10.2 ± 0.25 (0.400 ± 0.010)
(T) Thickness Max.	1.35 (0.053)	1.80 (0.071)	2.80 (0.110)	2.20 (0.087)	2.80 (0.110)	3.40 (0.134)	3.40 (0.134)	2.54 (0.100)	2.54 (0.100)
(t) terminal min. max.	0.50 ± 0.20 (0.020 ± 0.008)	0.60 ± 0.20 (0.024 ± 0.008)	0.75 ± 0.35 (0.030 ± 0.014)	0.75 ± 0.35 (0.030 ± 0.014)	0.75 ± 0.35 (0.030 ± 0.014)	0.75 ± 0.35 (0.030 ± 0.014)	0.85 ± 0.35 (0.033 ± 0.014)	0.85 ± 0.35 (0.033 ± 0.014)	0.76 (0.030) 1.52 (0.060)

*Reflow Soldering Only



High Voltage MLC Chips

For 600V to 5000V Applications



NP0 (C0G) Dielectric Performance Characteristics

Capacitance Range	10 pF to 0.100 μF (25°C, 1.0 ±0.2 Vrms at 1kHz, for ≤ 1000 pF use 1 MHz)
Capacitance Tolerances	±5%, ±10%, ±20%
Dissipation Factor	0.1% max. (+25°C, 1.0 ±0.2 Vrms, 1kHz, for ≤ 1000 pF use 1 MHz)
Operating Temperature Range	-55°C to +125°C
Temperature Characteristic	0 ±30 ppm/°C (0 VDC)
Voltage Ratings	600, 630, 1000, 1500, 2000, 2500, 3000, 4000 & 5000 VDC (+125°C)
Insulation Resistance (+25°C, at 500 VDC)	100K MΩ min. or 1000 MΩ - μF min., whichever is less
Insulation Resistance (+125°C, at 500 VDC)	10K MΩ min. or 100 MΩ - μF min., whichever is less
Dielectric Strength	Minimum 120% rated voltage for 5 seconds at 50 mA max. current

NP0 (C0G) CAPACITANCE RANGE - PREFERRED SIZES ARE SHADED

Case Size Soldering	0805			1206				1210				1808						1812					
	Reflow/Wave	Reflow/Wave	Reflow/Wave	Reflow Only	Reflow Only	Reflow Only	Reflow Only	Reflow Only	Reflow Only	Reflow Only	Reflow Only	Reflow Only	Reflow Only	Reflow Only	Reflow Only	Reflow Only	Reflow Only	Reflow Only	Reflow Only	Reflow Only			
(L) Length mm (in.)	2.10 ± 0.20 (0.085 ± 0.008)	3.30 ± 0.30 (0.130 ± 0.012)	3.30 ± 0.30 (0.130 ± 0.012)	4.60 ± 0.50 (0.181 ± 0.020)	4.60 ± 0.50 (0.181 ± 0.020)	4.60 ± 0.50 (0.181 ± 0.020)	4.60 ± 0.50 (0.181 ± 0.020)	4.60 ± 0.50 (0.181 ± 0.020)	4.60 ± 0.50 (0.181 ± 0.020)	4.60 ± 0.50 (0.181 ± 0.020)	4.60 ± 0.50 (0.181 ± 0.020)	4.60 ± 0.50 (0.181 ± 0.020)	4.60 ± 0.50 (0.181 ± 0.020)	4.60 ± 0.50 (0.181 ± 0.020)	4.60 ± 0.50 (0.181 ± 0.020)	4.60 ± 0.50 (0.181 ± 0.020)	4.60 ± 0.50 (0.181 ± 0.020)	4.60 ± 0.50 (0.181 ± 0.020)	4.60 ± 0.50 (0.181 ± 0.020)	4.60 ± 0.50 (0.181 ± 0.020)			
(W) Width mm (in.)	1.25 ± 0.20 (0.049 ± 0.008)	1.60 ± 0.30/0.10 (0.063 ± 0.012/-0.004)	1.60 ± 0.30/0.10 (0.063 ± 0.012/-0.004)	2.50 ± 0.30 (0.098 ± 0.012)	2.50 ± 0.30 (0.098 ± 0.012)	2.50 ± 0.30 (0.098 ± 0.012)	2.50 ± 0.30 (0.098 ± 0.012)	2.50 ± 0.30 (0.098 ± 0.012)	2.50 ± 0.30 (0.098 ± 0.012)	2.50 ± 0.30 (0.098 ± 0.012)	2.50 ± 0.30 (0.098 ± 0.012)	2.50 ± 0.30 (0.098 ± 0.012)	2.50 ± 0.30 (0.098 ± 0.012)	2.50 ± 0.30 (0.098 ± 0.012)	2.50 ± 0.30 (0.098 ± 0.012)	2.50 ± 0.30 (0.098 ± 0.012)	2.50 ± 0.30 (0.098 ± 0.012)	2.50 ± 0.30 (0.098 ± 0.012)	2.50 ± 0.30 (0.098 ± 0.012)	2.50 ± 0.30 (0.098 ± 0.012)			
(T) Thickness mm (in.)	1.35 (0.053)	1.80 (0.071)	1.80 (0.071)	2.80 (0.110)	2.80 (0.110)	2.80 (0.110)	2.80 (0.110)	2.80 (0.110)	2.80 (0.110)	2.80 (0.110)	2.80 (0.110)	2.80 (0.110)	2.80 (0.110)	2.80 (0.110)	2.80 (0.110)	2.80 (0.110)	2.80 (0.110)	2.80 (0.110)	2.80 (0.110)	2.80 (0.110)			
(t) Terminal mm (in.)	0.50 ± 0.20 (0.020 ± 0.008)	0.60 ± 0.20 (0.024 ± 0.008)	0.60 ± 0.20 (0.024 ± 0.008)	0.75 ± 0.35 (0.030 ± 0.014)	0.75 ± 0.35 (0.030 ± 0.014)	0.75 ± 0.35 (0.030 ± 0.014)	0.75 ± 0.35 (0.030 ± 0.014)	0.75 ± 0.35 (0.030 ± 0.014)	0.75 ± 0.35 (0.030 ± 0.014)	0.75 ± 0.35 (0.030 ± 0.014)	0.75 ± 0.35 (0.030 ± 0.014)	0.75 ± 0.35 (0.030 ± 0.014)	0.75 ± 0.35 (0.030 ± 0.014)	0.75 ± 0.35 (0.030 ± 0.014)	0.75 ± 0.35 (0.030 ± 0.014)	0.75 ± 0.35 (0.030 ± 0.014)	0.75 ± 0.35 (0.030 ± 0.014)	0.75 ± 0.35 (0.030 ± 0.014)	0.75 ± 0.35 (0.030 ± 0.014)	0.75 ± 0.35 (0.030 ± 0.014)			
Voltage (V)	600 630 1000	600 630 1000 1500 2000	600 630 1000 1500 2000 3000	600 630 1000 1500 2000 3000	600 630 1000 1500 2000 3000 4000	600 630 1000 1500 2000 2500 3000 4000	600 630 1000 1500 2000 2500 3000 4000	600 630 1000 1500 2000 2500 3000 4000	600 630 1000 1500 2000 2500 3000 4000	600 630 1000 1500 2000 2500 3000 4000	600 630 1000 1500 2000 2500 3000 4000	600 630 1000 1500 2000 2500 3000 4000	600 630 1000 1500 2000 2500 3000 4000	600 630 1000 1500 2000 2500 3000 4000	600 630 1000 1500 2000 2500 3000 4000	600 630 1000 1500 2000 2500 3000 4000	600 630 1000 1500 2000 2500 3000 4000	600 630 1000 1500 2000 2500 3000 4000	600 630 1000 1500 2000 2500 3000 4000	600 630 1000 1500 2000 2500 3000 4000			
Cap (pF)	.5 0R5	A C	A C	A C	A C	A C	A C	A C	A C	A C	A C	A C	A C	A C	A C	A C	A C	A C	A C	A C			
1.0 1R0	A C	A C	A C	A C	A C	A C	A C	A C	A C	A C	A C	A C	A C	A C	A C	A C	A C	A C	A C	A C			
1.2 1R2	A C	A C	A C	A C	A C	A C	A C	A C	A C	A C	A C	A C	A C	A C	A C	A C	A C	A C	A C	A C			
1.5 1R5	A C	A C	A C	A C	A C	A C	A C	A C	A C	A C	A C	A C	A C	A C	A C	A C	A C	A C	A C	A C			
1.8 1R8	A C	A C	A C	A C	A C	A C	A C	A C	A C	A C	A C	A C	A C	A C	A C	A C	A C	A C	A C	A C			
2.2 2R2	A C	A C	A C	A C	A C	A C	A C	A C	A C	A C	A C	A C	A C	A C	A C	A C	A C	A C	A C	A C			
2.7 2R7	A C	A C	A C	A C	A C	A C	A C	A C	A C	A C	A C	A C	A C	A C	A C	A C	A C	A C	A C	A C			
3.3 3R3	A C	A C	A C	A C	A C	A C	A C	A C	A C	A C	A C	A C	A C	A C	A C	A C	A C	A C	A C	A C			
3.9 3R9	A C	A C	A C	A C	A C	A C	A C	A C	A C	A C	A C	A C	A C	A C	A C	A C	A C	A C	A C	A C			
4.7 4R7	A C	A C	A C	A C	A C	A C	A C	A C	A C	A C	A C	A C	A C	A C	A C	A C	A C	A C	A C	A C			
5.6 5R6	A C	A C	A C	A C	A C	A C	A C	A C	A C	A C	A C	A C	A C	A C	A C	A C	A C	A C	A C	A C			
6.8 6R8	A C	A C	A C	A C	A C	A C	A C	A C	A C	A C	A C	A C	A C	A C	A C	A C	A C	A C	A C	A C			
8.2 8R2	A C	A C	A C	A C	A C	A C	A C	A C	A C	A C	A C	A C	A C	A C	A C	A C	A C	A C	A C	A C			
10 100	A C	A C	A C	A C	A C	A C	A C	A C	A C	A C	A C	A C	A C	A C	A C	A C	A C	A C	A C	A C			
12 120	A C	A C	A C	A C	A C	A C	A C	A C	A C	A C	A C	A C	A C	A C	A C	A C	A C	A C	A C	A C			
15 150	A C	A C	A C	A C	A C	A C	A C	A C	A C	A C	A C	A C	A C	A C	A C	A C	A C	A C	A C	A C			
18 180	A C	A C	A C	A C	A C	A C	A C	A C	A C	A C	A C	A C	A C	A C	A C	A C	A C	A C	A C	A C			
22 220	A C	A C	A C	A C	A C	A C	A C	A C	A C	A C	A C	A C	A C	A C	A C	A C	A C	A C	A C	A C			
27 270	A C	A C	A C	A C	A C	A C	A C	A C	A C	A C	A C	A C	A C	A C	A C	A C	A C	A C	A C	A C			
33 330	A C	A C	A C	A C	A C	A C	A C	A C	A C	A C	A C	A C	A C	A C	A C	A C	A C	A C	A C	A C			
39 390	A C	A C	A C	A C	A C	A C	A C	A C	A C	A C	A C	A C	A C	A C	A C	A C	A C	A C	A C	A C			
47 470	A C	A C	A C	A C	A C	A C	A C	A C	A C	A C	A C	A C	A C	A C	A C	A C	A C	A C	A C	A C			
56 560	A C	A C	A C	A C	A C	A C	A C	A C	A C	A C	A C	A C	A C	A C	A C	A C	A C	A C	A C	A C			
68 680	A C	A C	A C	A C	A C	A C	A C	A C	A C	A C	A C	A C	A C	A C	A C	A C	A C	A C	A C	A C			
82 820	A C	A C	A C	A C	A C	A C	A C	A C	A C	A C	A C	A C	A C	A C	A C	A C	A C	A C	A C	A C			
100 101	A C	A C	A C	A C	A C	A C	A C	A C	A C	A C	A C	A C	A C	A C	A C	A C	A C	A C	A C	A C			
120 121	A C	A C	A C	A C	A C	A C	A C	A C	A C	A C	A C	A C	A C	A C	A C	A C	A C	A C	A C	A C			
150 151	A C	A C	A C	A C	A C	A C	A C	A C	A C	A C	A C	A C	A C	A C	A C	A C	A C	A C	A C	A C			
180 181	A C	A C	A C	A C	A C	A C	A C	A C	A C	A C	A C	A C	A C	A C	A C	A C	A C	A C	A C	A C			
220 221	A C	A C	A C	A C	A C	A C	A C	A C	A C	A C	A C	A C	A C	A C	A C	A C	A C	A C	A C	A C			
270 271	A C	A C	A C	A C	A C	A C	A C	A C	A C	A C	A C	A C	A C	A C	A C	A C	A C	A C	A C	A C			
330 331	A C	A C	A C	A C	A C	A C	A C	A C	A C	A C	A C	A C	A C	A C	A C	A C	A C	A C	A C	A C			
390 391	A C	A C	A C	A C	A C	A C	A C	A C	A C	A C	A C	A C	A C	A C	A C	A C	A C	A C	A C	A C			
470 471	A C	A C	A C	A C	A C	A C	A C	A C	A C	A C	A C	A C	A C	A C	A C	A C	A C	A C	A C	A C			
560 561	A C	A C	A C	A C	A C	A C	A C	A C	A C	A C	A C	A C	A C	A C	A C	A C	A C	A C	A C	A C			
680 681	A C	A C	A C	A C	A C	A C	A C	A C	A C	A C	A C	A C	A C	A C	A C	A C	A C	A C	A C	A C			
750 751	A C	A C	A C	A C	A C	A C	A C	A C	A C	A C	A C	A C	A C	A C	A C	A C	A C	A C	A C	A C			
820 821	A C	A C	A C	A C	A C	A C	A C	A C	A C	A C	A C	A C	A C	A C	A C	A C	A C	A C	A C	A C			
1000 102	A C	A C	A C	A C	A C	A C	A C	A C	A C	A C	A C	A C	A C	A C	A C	A C	A C	A C	A C	A C			
1200 122	A C	A C	A C	A C	A C	A C	A C	A C	A C	A C	A C	A C	A C	A C	A C	A C	A C	A C	A C	A C			
1500 152	A C	A C	A C	A C	A C	A C	A C	A C	A C	A C	A C	A C	A C	A C	A C	A C	A C	A C	A C	A C			
1800 182	A C	A C	A C	A C	A C	A C	A C	A C	A C	A C	A C	A C	A C	A C	A C	A C	A C	A C	A C	A C			
2200 222	A C	A C	A C	A C	A C	A C	A C	A C	A C	A C	A C	A C	A C	A C	A C	A C	A C	A C	A C	A C			
2700 272	A C	A C	A C	A C	A C	A C	A C	A C	A C	A C	A C	A C	A C	A C	A C	A C	A C	A C	A C	A C			
3300 332	A C	A C	A C	A C	A C	A C	A C	A C	A C	A C	A C	A C	A C	A C	A C	A C	A C	A C	A C	A C			
3900 392	A C	A C	A C	A C	A C	A C	A C	A C	A C	A C	A C	A C	A C	A C	A C	A C	A C	A C	A C	A C			
4700 472	A C	A C	A C	A C	A C	A C	A C	A C	A C	A C	A C	A C	A C	A C	A C	A C	A C	A C	A C	A C			
5600 562	A C	A C	A C	A C	A C	A C	A C	A C	A C	A C	A C	A C	A C	A C	A C	A C	A C	A C	A C	A C			
6800 682	A C	A C	A C	A C	A C	A C	A C	A C	A C	A C	A C	A C	A C	A C	A C	A C	A C	A C	A C	A C			
8200 822	A C	A C	A C	A C	A C	A C	A C	A C	A C	A C	A C	A C	A C	A C	A C	A C	A C	A C	A C	A C			
Cap (μF)	0.010 103	A C	A C	A C	A C	A C	A C	A C	A C	A C	A C	A C	A C	A C	A C	A C	A C	A C	A C	A C			
0.012 123	A C	A C	A C	A C	A C	A C	A C	A C	A C	A C	A C	A C	A C	A C	A C	A C	A C	A C	A C	A C			
0.015 153	A C	A C	A C																				

High Voltage MLC Chips

For 600V to 5000V Applications

X7R CAPACITANCE RANGE
PREFERRED SIZES ARE SHADED

Case Size	1825								2220								2225								3640										
Soldering	Reflow Only								Reflow Only								Reflow Only								Reflow Only										
(L) Length mm (in.)	4.60 ± 0.50 (0.181 ± 0.020)								5.70 ± 0.50 (0.224 ± 0.020)								5.70 ± 0.50 (0.225 ± 0.010)								9.14 ± 0.25 (0.360 ± 0.010)										
(W) Width mm (in.)	6.30 ± 0.40 (0.248 ± 0.016)								5.00 ± 0.40 (0.197 ± 0.016)								6.30 ± 0.40 (0.250 ± 0.010)								10.2 ± 0.25 (0.400 ± 0.010)										
(T) Thickness mm (in.)	3.40 (0.134)								3.40 (0.134)								3.40 (0.100)								2.54 (0.100)										
(t) Terminal min max	0.75 ± 0.35 (0.030 ± 0.014)								0.85 ± 0.35 (0.033 ± 0.014)								0.85 ± 0.35 (0.033 ± 0.014)								0.76 (0.030) 1.52 (0.060)										
Voltage (V)	600	630	1000	1500	2000	2500	3000	4000	600	630	1000	1500	2000	2500	3000	4000	5000	600	630	1000	1500	2000	2500	3000	4000	5000	600	630	1000	1500	2000	2500	3000	4000	5000
Cap (pF) 100 101																																			
120 121																																			
150 151																																			
180 181																																			
220 221																																			
270 271																																			
330 331																																			
390 391																																			
470 471																																			
560 561																																			
680 681																																			
750 751																																			
820 821																																			
1000 102	F	F	F	F	F	F	F	F	F	F	F	F	F	F	F	G										F	F	F	F	F	F	F	F	F	
1200 122	F	F	F	F	F	F	F	F	F	F	F	F	F	F	F	G										F	F	F	F	F	F	F	F	F	
1500 152	F	F	F	F	F	F	F	F	F	F	F	F	F	F	F	G										F	F	F	F	F	F	F	F	F	
1800 182	F	F	F	F	F	F	F	F	F	F	F	F	F	F	F	G										F	F	F	F	F	F	F	F	F	
2200 222	F	F	F	F	F	F	F	F	F	F	F	F	F	F	F	G										F	F	F	F	F	F	F	F	F	
2700 272	F	F	F	F	F	F	F	F	F	F	F	F	F	F	F	G										F	F	F	F	F	F	F	F	F	
3300 332	F	F	F	F	F	F	F	F	F	F	F	F	F	F	F	G										F	F	F	F	F	F	F	F	F	
3900 392	F	F	F	F	F	F	F	F	F	F	F	F	F	F	F	G										F	F	F	F	F	F	F	F	F	
4700 472	F	F	F	F	F	F	F	F	F	F	F	F	F	F	F	G										F	F	F	F	F	F	F	F	F	
5600 562	F	F	F	F	F	F	F	F	F	F	F	F	F	F	F	G										F	F	F	F	F	F	F	F	F	
6800 682	F	F	F	G	G	G	G	G	F	F	F	F	F	F	F	G										F	F	F	F	F	F	F	F	G	
8200 822	F	F	F	G	G	G	G	G	F	F	F	G	G	G	G	G										F	F	F	F	F	F	F	F	G	
Cap (µF) 0.010 103	F	F	F	G	G	G	G	G	F	F	F	G	G	G	G	G										F	F	F	F	F	F	F	F	G	
0.015 153	F	F	F	G	G	G	G	G	F	F	F	G	G	G	G	G										F	F	F	G	G	G	G	G	G	
0.018 183	F	F	F	G	G				F	F	F	G	G	G	G	G										F	F	F	G	G	G	G	G	G	
0.022 223	F	F	F	G	G				F	F	F	G	G													F	F	F	G	G	G	G	G	G	
0.027 273	F	F	F	G					F	F	F	G	G													F	F	F	G	G					
0.033 333	F	F	F	G					F	F	F	G														F	F	F	G						
0.039 393	F	F	F	G					F	F	F	G														F	F	F	G						
0.047 473	F	F	F	P					F	F	F	G														F	F	F	G						
0.056 563	F	F	F	G					F	F	F	G														F	F	F	G						
0.068 683	F	F	G						F	F	G															F	F	F	G						
0.082 823	F	F	G						F	F	G															F	F	G							
0.100 104	F	F	G						F	F	G															F	F	G							
0.150 154	F	F							F	F	G															F	F	G							
0.220 224	F	F							F	F	G															F	F								
0.270 274	F	F							F	F																F	F								
0.330 334	F	F							F	F																F	F								
0.390 394	F	F							F	F																F	F								
0.470 474	F	F							F	F																F	F								
0.560 564	G	G							G	G																F	F								
0.680 684									G	G																G	G								
0.820 824																										G	G								
1.000 105																																			
Voltage (V)	600	630	1000	1500	2000	2500	3000	4000	600	630	1000	1500	2000	2500	3000	4000	5000	600	630	1000	1500	2000	2500	3000	4000	5000	600	630	1000	1500	2000	2500	3000	4000	5000
Case Size	1825								2220								2225								3640										

Letter	A	C	E	F	G	X	7
Max. Thickness	0.813 (0.032)	1.448 (0.057)	1.8034 (0.071)	2.2098 (0.087)	2.794 (0.110)	0.940 (0.037)	3.30 (0.130)

NOTE: Contact factory for non-specified capacitance values



Looking for pricing, stock, or lifecycle information?

Click below to explore more details on WIN SOURCE:

 [View 1812CC101KAT1A\SB on WIN SOURCE](#)

 [AVX Corporation](#) Information

Optimize Your Supply Chain with WIN SOURCE Solutions

-  Global Sourcing Solution
-  Obsolete Management
-  Cost Control Management
-  Shortage Management
-  Alternative Solution
-  Excess Inventory Management