



**THE DATASHEET OF
M85049/85-24W02**





AS85049/85, AS85049/86 and AS85049/87 Straight, 45° and 90° Banding Backshells with Self-Locking Coupling

CONNECTOR DESIGNATOR:

F	MIL-DTL-38999 Series I and II 40M38277, PAN 6433-1 PATT 614, PATT 616 NFC93422 Series HE308 and HE309

Basic Part Number

M85049/85 = Straight
M85049/86 = 45°
M85049/87 = 90°

— = Detented
N = Non-Detented

Shell Size
(Table I)

Entry Size
(Table I)

M85049/85 - N 16 P 02

Finish

- N = Electroless Nickel
- P = Cadmium, Olive Drab over Electroless Nickel with Polysulfide Sealant Strips
- W = 1,000 Hr. Cadmium Olive Drab over Electroless Nickel
- X = Aluminum, Nickel Fluorocarbon Polymer
- YP = Aluminum, Pure Dense Electrodeposited Aluminum with Polysulfide Sealant Strips
- Z = Aluminum, Zinc-Nickel, Black
- ZP = Aluminum, Zinc Nickel with Polysulphide Sealant Strips

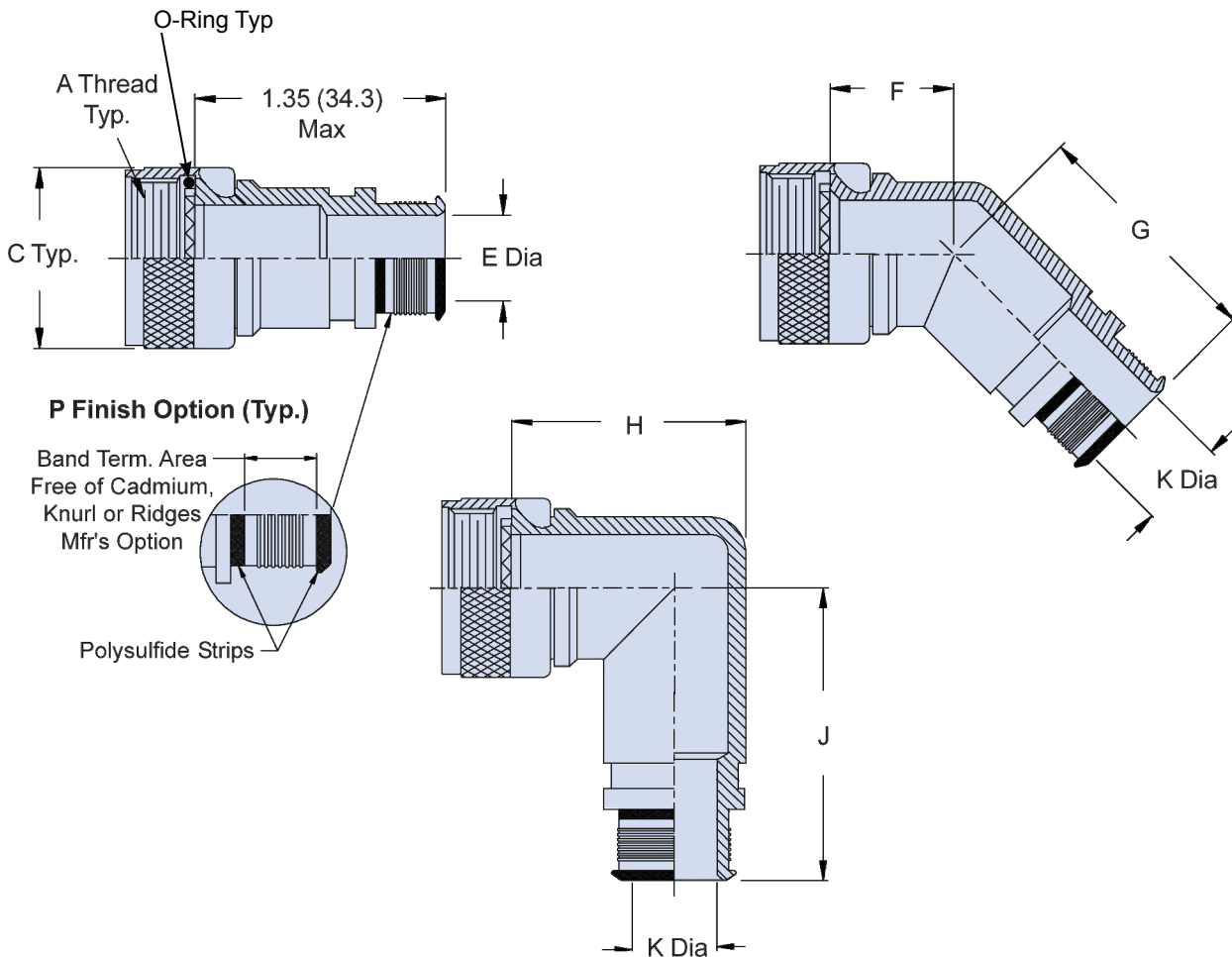

AS85049/85, AS85049/86 and AS85049/87
Straight, 45° and 90° Banding Backshells
with Self-Locking Coupling



TABLE I: Shell Size, Cable Entry and Backshell Dimensions

Shell Size	A Thread Class 2B	C Dia Max	F Max	G Max	H Max	J Max
08	.438 - 28 UNEF	.860 (21.8)	.870 (22.1)	1.160 (29.5)	1.375 (34.9)	1.375 (34.9)
10	.562 - 24 UNEF	.990 (25.1)	.900 (22.9)	1.190 (30.2)	1.437 (36.5)	1.437 (36.5)
12	.688 - 24 UNEF	1.160 (29.5)	.920 (23.4)	1.210 (30.7)	1.562 (39.7)	1.562 (39.7)
14	.813 - 20 UNEF	1.280 (32.5)	.950 (24.1)	1.240 (31.5)	1.687 (42.8)	1.687 (42.8)
16	.938 - 20 UNEF	1.410 (35.8)	.980 (24.9)	1.260 (32.0)	1.750 (44.5)	1.750 (44.5)
18	1.063 - 18 UNEF	1.520 (38.6)	.980 (24.9)	1.270 (32.3)	1.875 (47.6)	1.875 (47.6)
20	1.188 - 18 UNEF	1.640 (41.7)	1.010 (25.7)	1.300 (33.0)	1.938 (49.2)	1.938 (49.2)
22	1.313 - 18 UNEF	1.770 (45.0)	1.040 (26.4)	1.330 (33.8)	2.062 (52.4)	2.062 (52.4)
24	1.438 - 18 UNEF	1.890 (48.0)	1.070 (27.2)	1.350 (34.3)	2.125 (54.0)	2.125 (54.0)

TABLE II: Shell Size and Cable Entry for Straight Configuration Only

Shell Size	E Dia Cable Entry Size 01 ±.010 (0.30)	E Dia Cable Entry Size 02 ±.010 (0.30)
08	N/A	.250 (6.4)
10	N/A	.312 (7.9)
12	.312 (7.9)	.438 (11.1)
14	.438 (11.1)	.562 (14.3)
16	.500 (12.7)	.625 (15.9)
18	.625 (15.9)	.750 (19.1)
20	.625 (15.9)	.812 (20.6)
22	.688 (17.5)	.938 (23.8)
24	.750 (19.1)	1.000 (25.4)

TABLE III: Shell Size and Cable Entry for 45° and 90° Configurations Only

Shell Size	K Dia Cable Entry Size 02 ±.010 (0.30)	K Dia Cable Entry Size 03 ±.010 (0.30)
08	N/A	.250 (6.4)
10	N/A	.312 (7.9)
12	.312 (7.9)	.438 (11.1)
14	.438 (11.1)	.562 (14.3)
16	.500 (12.7)	.625 (15.9)
18	.625 (15.9)	.750 (19.1)
20	.625 (15.9)	.812 (20.6)
22	.688 (17.5)	.938 (23.8)
24	.750 (19.1)	1.000 (25.4)

APPLICATION NOTES

1. Assembly identified with manufacturer's name and part number, space permitting.
2. For complete dimensions, see the applicable Military Specification.
3. Metric dimensions (mm) are in parentheses.
4. For use with AS85049/128 Bands.

Looking for pricing, stock, or lifecycle information?

Click below to explore more details on WIN SOURCE:

 [View M85049/85-24W02 on WIN SOURCE](#)

 [Glenair, Inc. Information](#)

Optimize Your Supply Chain with WIN SOURCE Solutions

-  Global Sourcing Solution
-  Obsolete Management
-  Cost Control Management
-  Shortage Management
-  Alternative Solution
-  Excess Inventory Management