



**THE DATASHEET OF
AT89C5122D-RDVIM**



Features

- **Clock Controller**
 - 80C51 core with 6 clocks per instruction
 - 8 MHz On-Chip Oscillator
 - PLL for generating clock to supply CPU core, USB and Smart Card Interfaces
 - Programmable CPU clock from 500 KHz / X1 to 48 MHz / X1
- **Reset Controller**
 - Power On Reset (POR) feature avoiding an external reset capacitor
 - Power Fail Detector (PFD)
 - Watch-Dog Timer
- **Power Management**
 - Two power saving modes : Idle and Power Down
 - Four Power Down Wake-up Sources : Smart Card Detection, Keyboard Interrupt, USB Resume, External Interrupt
 - Input Voltage Range : 3.0V - 5.5V
 - Core's Power Consumption (Without Smart Card and USB) :
 - 30 mA Maximum Operating Current @ 48 MHz / X1
 - 200 μ A Maximum Power-down Current @ 5.5V
- **Interrupt Controller**
 - up to 9 interrupt sources
 - up to 4 Level Priority
- **Memory Controller**
 - Internal Program memory :
 - up to 32KB of Flash or CRAM or ROM for AT8xC5122 or ROM for AT83R5122
 - up to 30KB of ROM for AT83C5123
 - Internal Data Memory : 768 bytes including 256 bytes of data and 512 bytes of XRAM
 - Optional : internal data E2PROM 512 bytes
- **Two 16-bit Timer/Counters**
- **USB 2.0 Full Speed Interface**
 - 48 MHz DPLL
 - On-Chip 3.3V USB voltage regulator and transceivers
 - Software detach feature
 - 7 endpoints programmable with In or out directions and ISO, Bulk or Interrupt Transfers :
 - Endpoint 0: 32 Bytes Bidirectionnal FIFO for Control transfers
 - Endpoints 1,2,3: 8 bytes FIFO
 - Endpoints 4,5: 64 Bytes FIFO
 - Endpoint 6: 2*64 bytes FIFO with Pin-Pong feature
- **ISO 7816 UART Interface Fully Compliant with EMV, GIE-CB and WHQL Standards**
 - Programmable ISO clock from 1 MHz to 4.8 MHz
 - Card insertion/removal detection with automatic deactivation sequence
 - Programmable Baud Rate Generator from 372 to 11.625 clock pulses
 - Synchronous/Asynchronous Protocols T=0 and T=1 with Direct or Inverse Convention
 - Automatic character repetition on parity errors
 - 32 Bit Waiting Time Counter
 - 16 Bit Guard Time Counter
 - Internal Step Up/Down Converter with Programmable Voltage Output:
 - VCC = 4.0V to 5.5V, 1.8V-30 mA, 3V-60 mA and 5V-60 mA
 - VCC = 3.0V, 1.8V-30 mA, 3V-30 mA and 5V-30 mA
 - Current overload protection
 - 6 kV ESD (MIL/STD 883 Class 3) protection on whole Smart Card Interface
- **Alternate Smart Card Interface with CLK, IO and RST**
- **UART Interface with Integrated Baud Rate Generator (BRG)**
- **Keyboard interface with up to 20x8 matrix management capability**
- **Master/Slave SPI Interface**
- **Four 8 bit Ports, one 6 bit port, one 3-bit port**
 - Up to Seven LED outputs with 3 level programmable current source : 2, 4 and 10 mA
 - Two General Purpose I/O programmable as external interrupts
 - Up to 8 input lines programmable as interrupts
 - Up to 30 output lines



C51 Microcontroller with USB and Smart Card Reader Interfaces

AT83C5122
AT83R5122
AT85C5122
AT89C5122
AT89C5122DS
AT83C5123



Rev. 4202F-SCR-07/2008





Reference Documents

The user must get the following additional documents which are not included but which complete this product datasheet

- Product Errata Sheet
- Bootloader Datasheet

Product Description

AT8xC5122/23 products are high-performance CMOS derivatives of the 80C51 8-bit microcontrollers designed for USB smart card reader applications.

The AT8xC5122 is proposed in four versions :

- ROM version referenced AT83R5122 is only factory programmable.
- CRAM version without internal data E2PROM. The CRAM device implements a volatile program memory which is programmed by means of an embedded ROMed bootloader which transfers the code from a remote software programming tool called FLIP through UART or USB interfaces.
- Flash version without internal data E2PROM. At power-up, the program located in the flash memory is transferred into the CRAM then executed.

The AT83C5123 is a low pin count of the AT8xC5122 and is proposed in ROM version with or without internal data E2PROM. The ROM device is only factory programmable.

The AT8xC5122DS is a secure version of the AT8xC5122 on which the external program memory access mode is disabled.

Table 1. Product versions

Features		AT83C5122 AT83R5122	AT85C5122	AT89C5122	AT89C5122DS	AT83C5123
Packages		VQFP64 QFN64 Die Form	PLCC68 VQFP64 Die Form	VQFP64 QFN64	VQFP64 QFN64	VQFP32 QFN32 Die Form
Program memory		32KB ROM	32KB CRAM	32KB E2PROM	32KB E2PROM	30KB ROM
Internal Data E2PROM		No	No	No	No	No
Embedded bootloader		No	Yes	Yes	Yes	No
Features	VQFP32, QFN32 packages					Features not available : - Keyboard Interface - Master/Slave SPI Interface - External Program Memory Access Reduced features : - Only 12 I/O with up to 4 LED Outputs with Programmable Current
	PLCC68, VQFP64,QFN64 packages	All features are available			All features are available except External Program Memory Access	

AT8xC5122/AT83R5122 Block Diagram

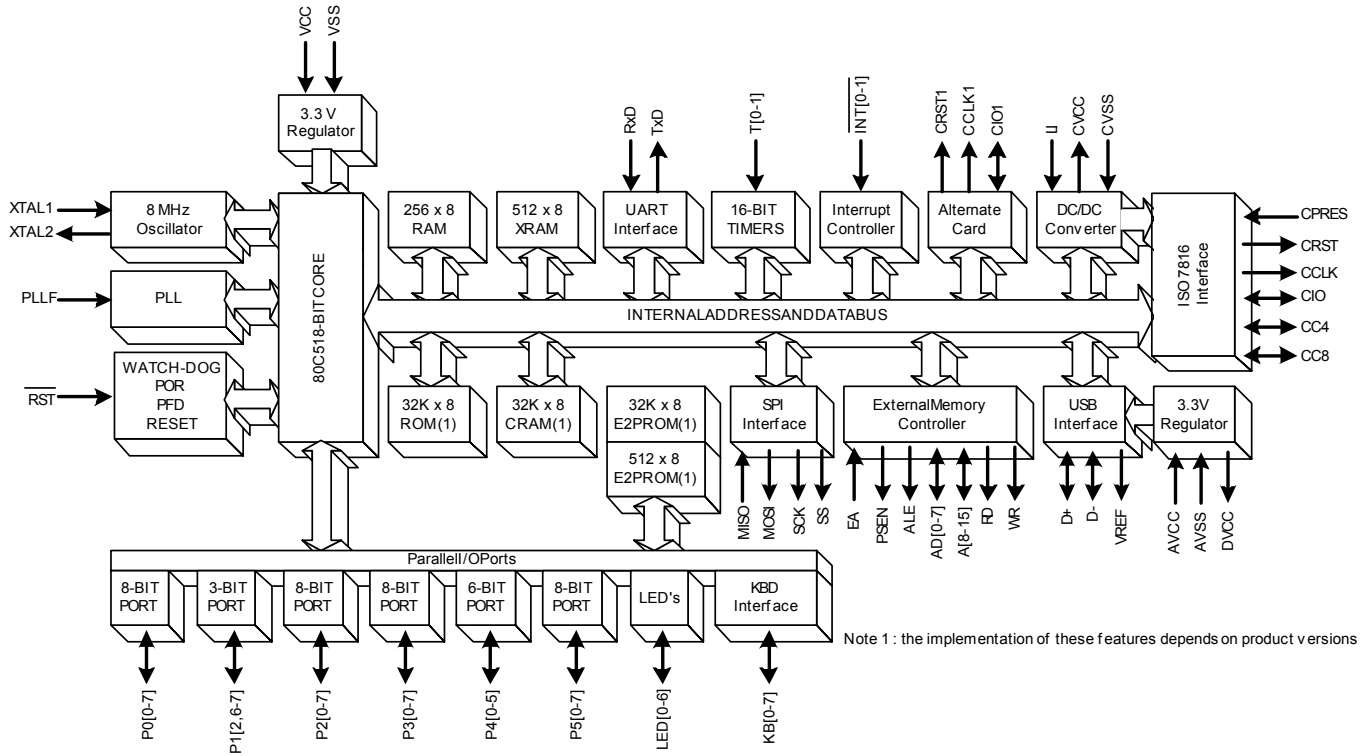

AT83C5123 Block Diagram

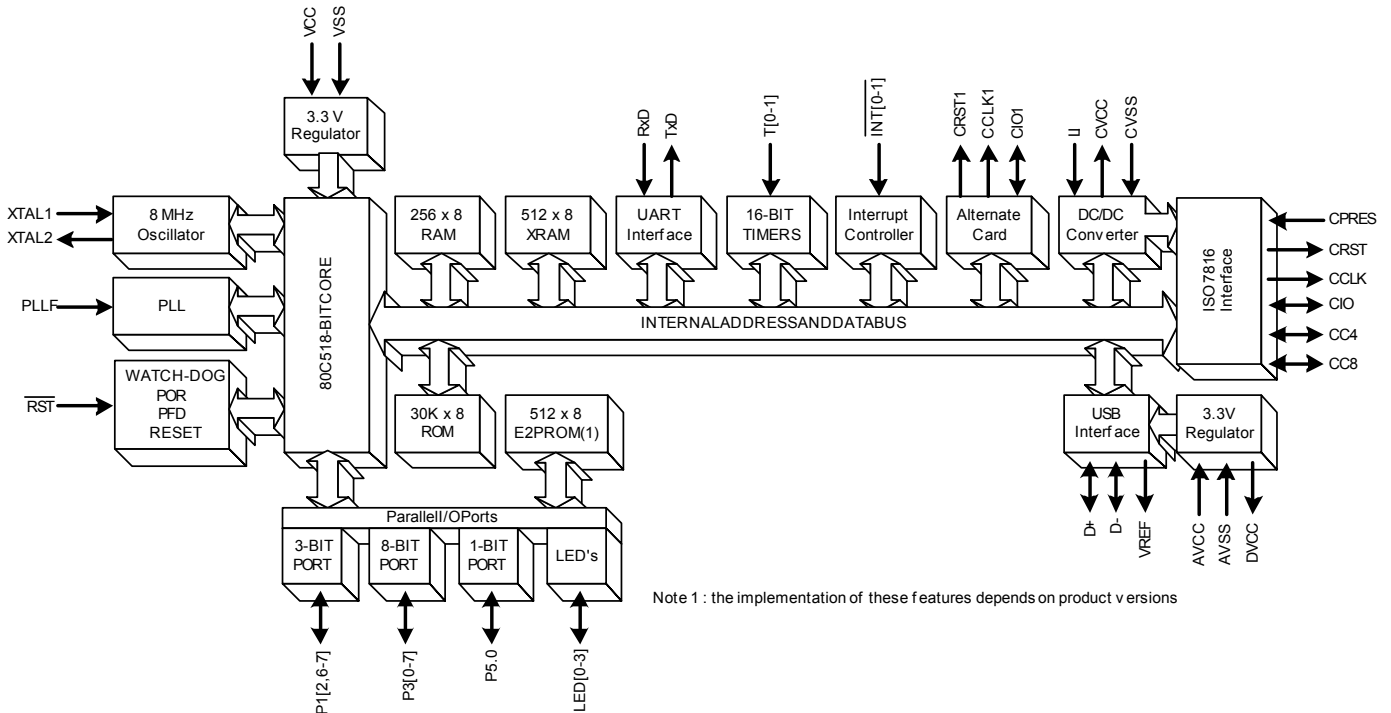

Pinout

High Pin Count Package Description

AT8xC5122/AT83R5122
version

Figure 1. VQFP64 Package Pinout

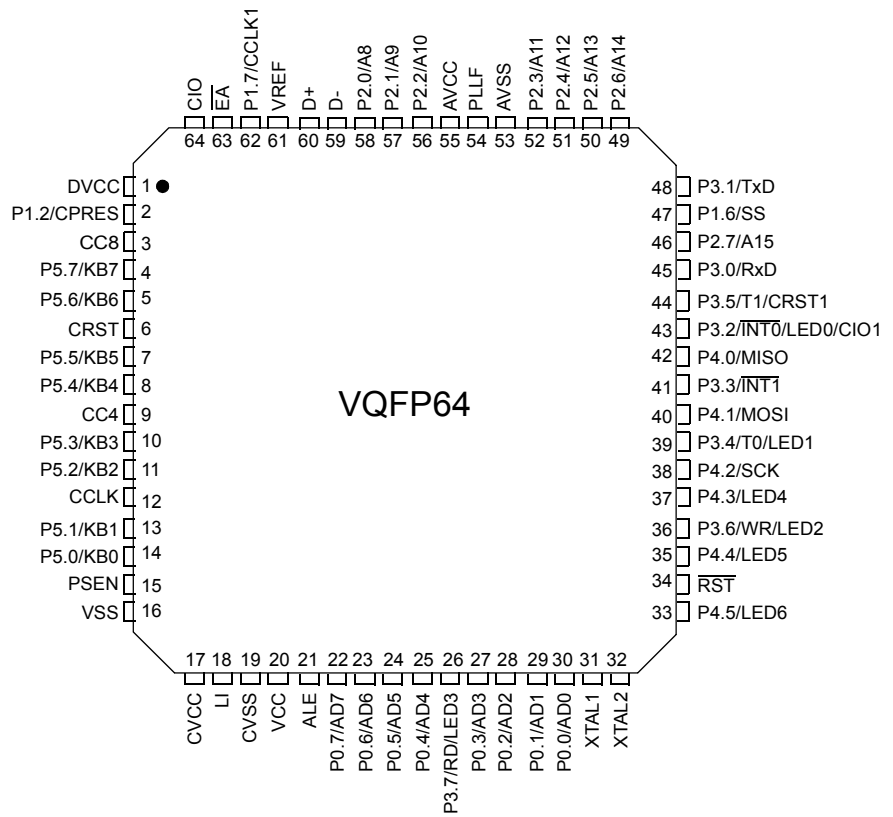

Figure 2. PLCC68 Package Pinout (for engineering purpose only)

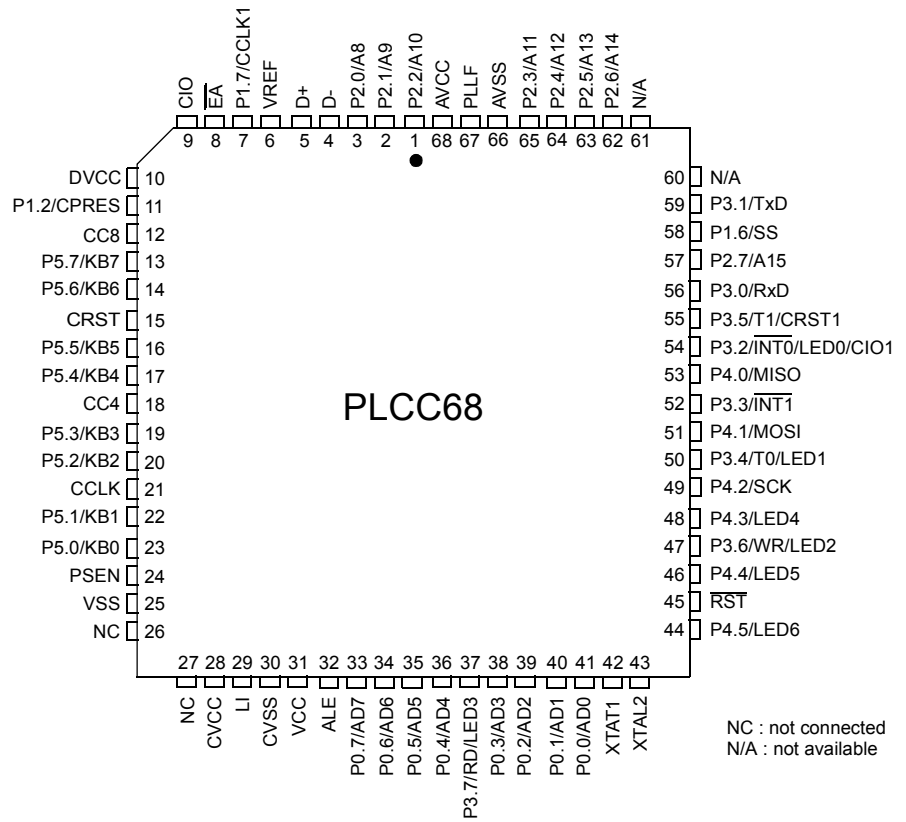

Figure 3. QFN64 Package Pinout

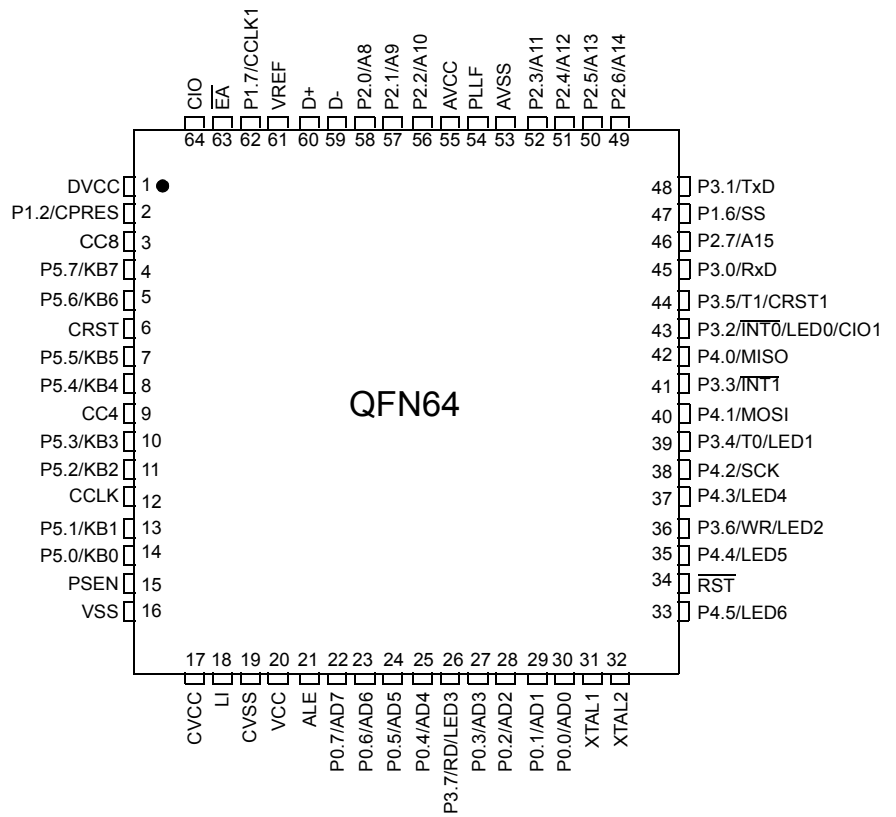



Figure 4. VQFP64 Package Pinout

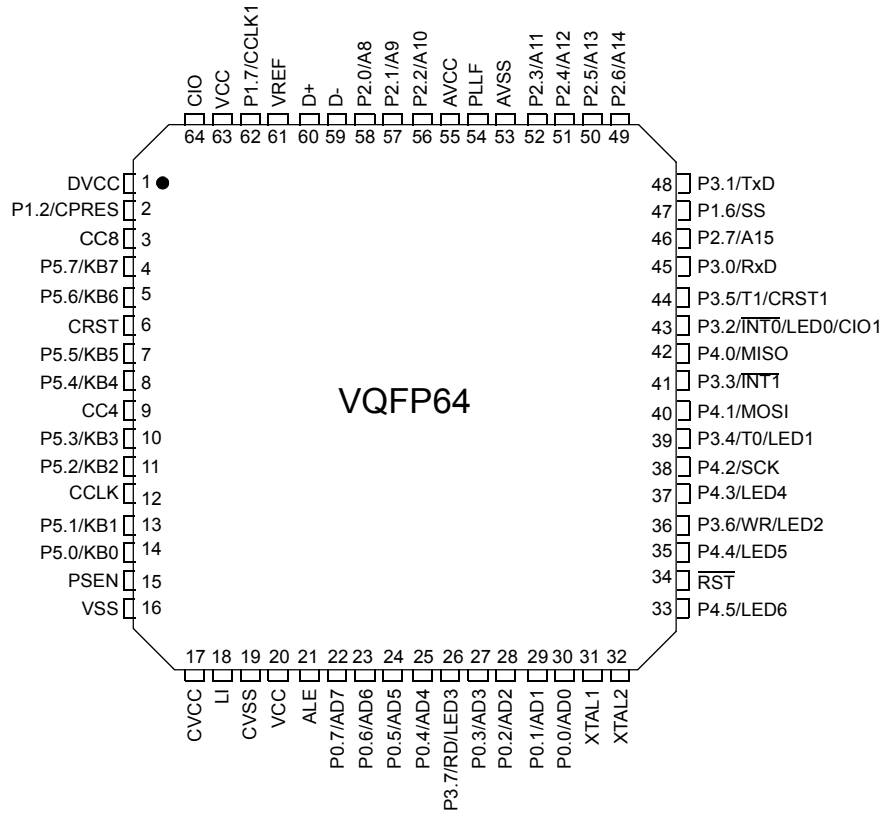
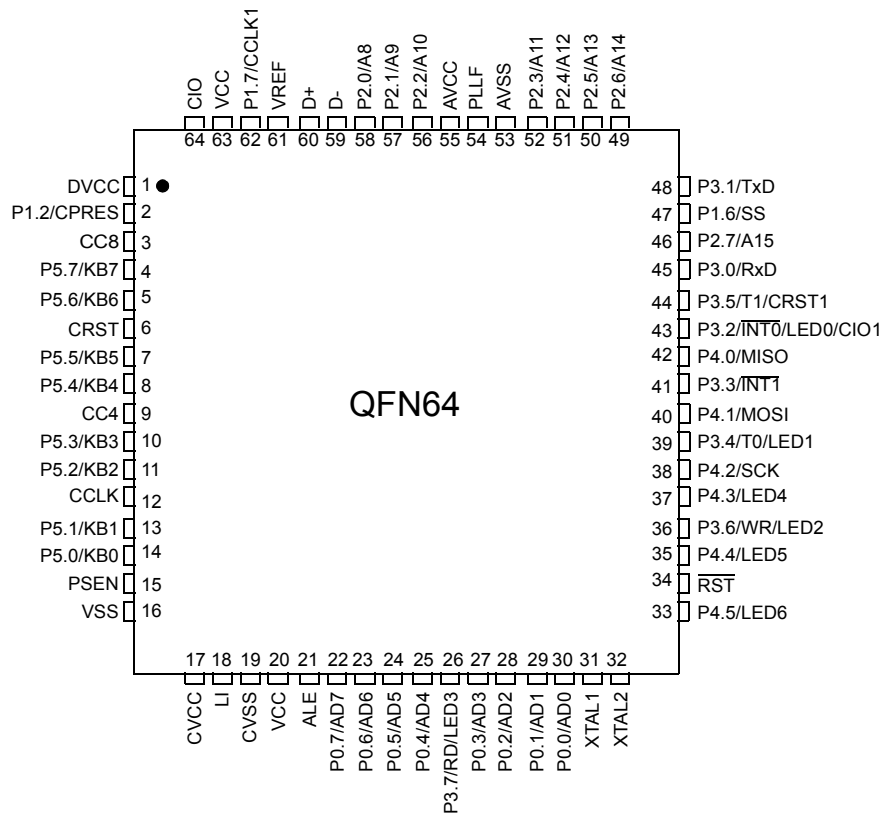

Figure 5. QFN64 Package Pinout



Low Pin Count Package Description

AT83C5123 version

Figure 6. VQFP32 Package Pinout

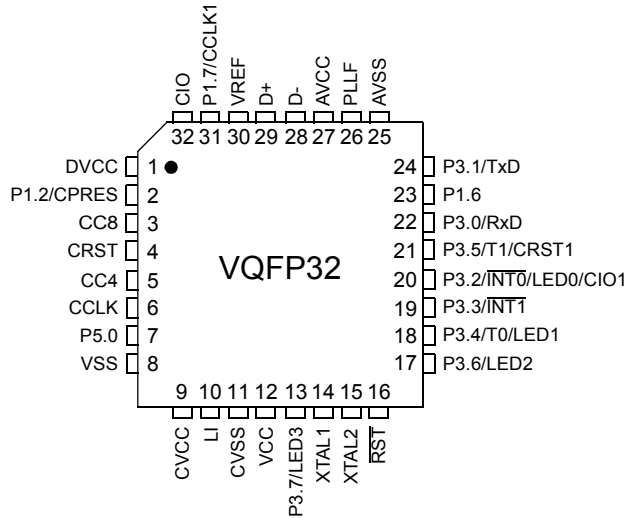
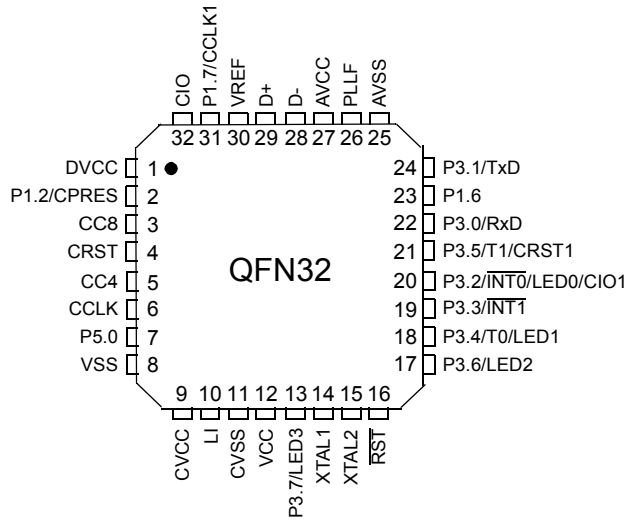

Figure 7. QFN32 Package Pinout



Pin Description

Table 2. Pin Description

Port	VQFP64	VQFP32	PLCC68	PLCC28	QFN64	QFN32	Internal Power Supply	ESD	I/O	Reset Level	Alt	Reset Config	Conf 1	Conf 2	Conf 3	Led
P0.0	30	-	41	-	30	-	VCC	2KV	I/O	Float	AD0	P0		KB_OUT	Push-pull	
P0.1	29	-	40	-	29	-	VCC	2KV	I/O	Float	AD1	P0		KB_OUT	Push-pull	
P0.2	28	-	39	-	28	-	VCC	2KV	I/O	Float	AD2	P0		KB_OUT	Push-pull	
P0.3	27	-	38	-	27	-	VCC	2KV	I/O	Float	AD3	P0		KB_OUT	Push-pull	
P0.4	25	-	36	-	25	-	VCC	2KV	I/O	Float	AD4	P0		KB_OUT	Push-pull	
P0.5	24	-	35	-	24	-	VCC	2KV	I/O	Float	AD5	P0		KB_OUT	Push-pull	
P0.6	23	-	34	-	23	-	VCC	2KV	I/O	Float	AD6	P0		KB_OUT	Push-pull	
P0.7	22	-	33	-	22	-	VCC	2KV	I/O	Float	AD7	P0		KB_OUT	Push-pull	
CIO	64	32	9	4	64	32	CVCC	6KV	I/O	0		Port51	CVCC inactive at reset. ESD tested with a 10µF on CVCC An external pull-up of 10K is recommended to support ICC's with too weak internal pull-ups.			
CC4	3	3	12	7	3	3	CVCC	6KV	I/O	0		Port51	CVCC inactive at reset ESD tested with a 10µF on CVCC			
P1.2	2	2	11	6	2	2	VCC	2KV	I/O	1	CPRES	Port51	Weak & medium pull-up can be disconnected			
CC4	9	5	18	9	9	5	CVCC	6KV	I/O	0		Port51	CVCC inactive at reset ESD tested with a 10µF on CVCC			
CCLK	12	6	21	10	12	6	CVCC	6KV	O	0		Push-pull	CVCC inactive at reset ESD tested with a 10µF on CVCC			
CRST	6	4	15	8	6	4	CVCC	6KV	O	0		Push-pull	CVCC inactive at reset ESD tested with a 10µF on CVCC			
P1.6	47	23	58	-	47	23	VCC	2KV	I/O	1	SS	Port51				
P1.7	62	31	7	-	62	31	VCC	2KV	I/O	1	CCLK1	Port51				
P2.0	58	-	3	-	58	-	VCC	2KV	I/O	1	A8	Port51	Push-pull	KB_OUT	Input WPU	
P2.1	57	-	2	-	57	-	VCC	2KV	I/O	1	A9	Port51	Push-pull	KB_OUT	Input WPU	
P2.2	56	-	1	-	56	-	VCC	2KV	I/O	1	A10	Port51	Push-pull	KB_OUT	Input WPU	
P2.3	52	-	65	-	52	-	VCC	2KV	I/O	1	A11	Port51	Push-pull	KB_OUT	Input WPU	
P2.4	51	-	64	-	51	-	VCC	2KV	I/O	1	A12	Port51	Push-pull	KB_OUT	Input WPU	
P2.5	50	-	63	-	50	-	VCC	2KV	I/O	1	A13	Port51	Push-pull	KB_OUT	Input WPU	



Table 2. Pin Description (Continued)

Port	VQFP64	VQFP32	PLCC68	PLCC28	QFN64	QFN32	Internal Power Supply	ESD	I/O	Reset Level	Alt	Reset Config	Conf 1	Conf 2	Conf 3	Led
P2.6	49	-	62	-	49	-	VCC	2KV	I/O	1	A14	Port51	Push-pull	KB_OUT	Input WPU	
P2.7	46	-	57	-	46	-	VCC	2KV	I/O	1	A15	Port51	Push-pull	KB_OUT	Input WPU	
P3.0	45	22	56	24	45	22	VCC	2KV	I/O	1	RxD	Port51	Push-pull	KB_OUT	Input WPU	
P3.1	48	24	59	25	48	24	VCC	2KV	I/O	1	TxD	Port51	Push-pull	KB_OUT	Input WPU	
P3.2	43	20	54	23	43	20	VCC	2KV	I/O	1	INT0	Port51				LED0
P3.3	41	19	52	22	41	19	VCC	2KV	I/O	1	INT1	Port51	Push-pull	KB_OUT	Input WPU	
P3.4	39	18	50	21	39	18	VCC	2KV	I/O	1	T0	Port51	Push-pull	KB_OUT	Input WPU	LED1
P3.5	44	21	55	-	44	21	VCC	2KV	I/O	1	T1	Port51				
P3.6	36	17	47	20	36	17	VCC	2KV	I/O	1	WR	Port51				LED2
P3.7	26	13	37	16	26	13	VCC	2KV	I/O	1	RD	Port51				LED3
P4.0	42	-	53	-	42	-	VCC	2KV	I/O	1	MISO	Port51				
P4.1	40	-	51	-	40	-	VCC	2KV	I/O	1	MOSI	Port51				
P4.2	38	-	49	-	38	-	VCC	2KV	I/O	1	SCK	Port51				
P4.3	37	-	48	-	37	-	VCC	2KV	I/O	1		Port51	Push-pull	KB_OUT	Input MPU	LED4
P4.4	35	-	46	-	35	-	VCC	2KV	I/O	1		Port51	Push-pull	KB_OUT	Input MPU	LED5
P4.5	33	-	44	-	33	-	VCC	2KV	I/O	1		Port51	Push-pull	KB_OUT	Input MPU	LED6
P5.0	14	7	23	-	14	7	VCC	2KV	I/O	1	KB0	Port51	Push-pull	Input MPU	Input WPU	
P5.1	13	-	22	-	13	-	VCC	2KV	I/O	1	KB1	Port51	Push-pull	Input MPU	Input WPU	
P5.2	11	-	20	-	11	-	VCC	2KV	I/O	1	KB2	Port51	Push-pull	Input MPU	Input WPU	
P5.3	10	-	19	-	10	-	VCC	2KV	I/O	1	KB3	Port51	Push-pull	Input WPD	Input WPU	
P5.4	8	-	17	-	8	-	VCC	2KV	I/O	1	KB4	Port51	Push-pull	Input WPD	Input WPU	

Table 2. Pin Description (Continued)

Port	VQFP64	VQFP32	PLCC68	PLCC28	QFN64	QFN32	Internal Power Supply	ESD	I/O	Reset Level	Alt	Reset Config	Conf 1	Conf 2	Conf 3	Led
P5.5	7	-	16	-	7	-	VCC	2KV	I/O	1	KB5	Port51	Push-pull	Input WPD	Input WPU	
P5.6	5	-	14	-	5	-	VCC	2KV	I/O	1	KB6	Port51	Push-pull	Input WPD	Input WPU	
P5.7	4	-	13	-	4	-	VCC	2KV	I/O	1	KB7	Port51	Push-pull	Input WPD	Input WPU	
$\overline{\text{RST}}$	34	16	45	19	34	16	VCC		I/O			Reset Input The Port pins are driven to their reset conditions when a voltage lower than V_{IL} is applied, whether or not the oscillator is running. This pin has an internal 10K pull-up resistor which allows the device to be reset by connecting a capacitor between this pin and VSS. Asserting $\overline{\text{RST}}$ when the chip is in Idle mode or Power-Down mode returns the chip to normal operation. The output is active for at least 12 oscillator periods when an internal reset occurs.				
D+	60	29	5	2	60	29	DVCC		I/O			USB Positive Data Upstream Port This pin requires an external serial resistor of 27 Ω (AT8xC122) or 33 Ω (AT83C5123) and a 1.5 K Ω pull-up to V_{REF} for full speed configuration.				
D-	59	28	4	1	59	28	DVCC		I/O			USB Negative Data Upstream Port This pin requires an external serial resistor of 27 Ω (AT8xC122) or 33 Ω (AT83C5123)				
V_{REF}	61	30	6	3	61	30	AVCC		O			USB Voltage Reference: $3.0 < V_{REF} < 3.6 \text{ V}$ V_{REF} can be connected to D+ through a 1.5 K Ω resistor. The V_{REF} voltage is controlled by software.				
XTAL ₁	31	14	42	17	31	14	VCC		I			Input to the on-chip inverting oscillator amplifier To use the internal oscillator, a crystal or an external oscillator must be connected to this pin.				
XTAL ₂	32	15	43	18	32	15	VCC		O			Output of the on-chip inverting oscillator amplifier To use the internal oscillator, a crystal circuit must be connected to this pin. If an external oscillator is used, leave XTAL2 unconnected.				
$\overline{\text{EA}}/V_{CC}$	63	-	8	-	63	-	VCC		I			External Access Enable (Only AT8xC5122) $\overline{\text{EA}}$ must be strapped to ground in order to enable the device to fetch code from external memory locations 0000h to FFFFh. If security level 1 is programmed, $\overline{\text{EA}}$ will be latched on reset. Warning : EA pin cannot be left floating. If the External Access Enable mode is not used, EA pin must be strapped to VCC. If this last condition is not met, the MCU may have an unpredictable behaviour. VCC (Only AT89C5122DS)				
ALE	21	-	32	-	21	-	VCC		O			Address Latch Enable/Program Pulse: Output pulse for latching the low byte of the address during an access to external memory. In normal operation, ALE is emitted at a constant rate of 1/6 (1/3 in X2 mode) the oscillator frequency, and can be used for external timing or clocking. Note that one ALE pulse is skipped during each access to external data memory. ALE can be disabled by setting SFR's AUXR.0 bit. With this bit set, ALE will be inactive during internal fetches				

Table 2. Pin Description (Continued)

Port	VQFP64	VQFP32	PLCC68	PLCC28	QFN64	QFN32	Internal Power Supply	ESD	I/O	Reset Level	Alt	Reset Config	Conf 1	Conf 2	Conf 3	Led	
$\overline{\text{PSEN}}$	15	-	24	-	15	-	VCC		O								Program Strobe Enable: The read strobe to external program memory. When executing code from the external program memory, PSEN is activated twice each machine cycle, except that two PSEN activations are skipped during each access to external data memory. PSEN is not activated during fetches from internal program memory.
PLL	54	26	67	27	54	26	AVCC		O								PLL Low Pass Filter input Receives the RC network of the PLL low pass filter.
AVCC	55	27	68	28	55	27			PWR								Analog Supply Voltage AVCC is used to supply the internal 3.3V analog regulator which supplies the internal USB driver
VCC	20	12	31	15	20	12			PWR								Supply Voltage VCC is used to supply the internal 3.3V digital regulator which supplies the PLL, CPU core and internal I/O's
LI	18	10	29	13	18	10			PWR								DC/DC Input LI supplies the current for the charge pump of the DC/DC converter. - LI tied directly to VCC : the DC/DC converter must be configured in regulator mode. - LI tied to VCC through an external 10 μ H coil : the DC/DC converter can be configured either in regulator or in pump mode.
CVCC	17	9	28	12	17	9			PWR								Card Supply Voltage CVCC is the output of internal DC/DC converter which supplies the Smart Card Interface. It must be connected to an external decoupling capacitor of 10 μ F with the lowest ESR as this parameter influences on the CVCC noise
DVCC	1	1	10	5	1	1			PWR								Digital Supply Voltage DVCC is the output of the internal analog 3.3V regulator which supplies the USB driver. This pin must be connected to an external 680nF decoupling capacitor if the USB interface is used. This output can be used by the application with a maximum of 10 mA.
CVSS	19	11	30	14	19	11			GND								DC/DC Ground CVSS is used to sink high shunt currents from the external coil
VSS	16	8	25	11	16	8			GND								Digital Ground VSS is used to supply the PLL, buffer ring and the digital core
AVSS	53	25	66	26	53	25			GND								Analog Ground AVSS is used to supply the USB driver.

Typical Applications

Recommended External components

All the external components described in the figure and table below must be implemented as close as possible from the microcontroller package.

Table 3. External Components Bill Of Materials

Reference	Description	Value	Comments
R1	USB Full Speed Pull-up	1.5 K Ω +/-10%	All product versions
R2	USB pad serial resistor	27 Ω +/-10%	For AT8xC5122 versions
		33 Ω +/-10%	For AT83C5123 versions
R3	USB pad serial resistor	27 Ω +/-10%	For AT8xC5122 versions
		33 Ω +/-10%	For AT83C5123 versions
R4	PLL filter resistor	1.8 K Ω +/-10%	All product versions
R5	CIO Pull-up resistor	10 K Ω +/-10%	All product versions
C1	Power Supply filter capacitor	100 nF +80/-20%	All product versions
C2	PLL filter capacitor	33 pF +/-10%	All product versions
C3	PLL filter capacitor	150 pF +/-10%	All product versions
C4	USB pad decoupling capacitor	680 nF +/-30%	All product versions. If USB interface is not used, this capacitor is optional
C5	Smart Card clock filter capacitor	27 pF +/-10%	All product versions.
C6	DC/DC Converter decoupling capacitor	10 μ F +/-10% Low ESR	All product versions. This capacitor does not impact the USB Inrush Current
C7	DC/DC Converter filter capacitor	100 nF +80/-20%	All product versions
C8	Power Supply decoupling capacitor	4.7 μ F +/-10%	All products versions This capacitor impacts the USB Inrush Current. Maximum application capacitance allowed by the USB standard is 10 μ F.
C9	Power Supply filter capacitor	100 nF +80/-20C	All product versions
C10	Reset capacitor	10 μ F +/-10%	Optional capacitor for all product versions
L1	DC/DC converter input inductance	10 μ H +/- 10% Min rated current : 200 mA Min rated freq. : 4 MHz	All product versions. Qualified component : Murata LQH32CN100K21L If DC/DC converter is not used at 5V, this inductance is optional.
Q1	Crystal	8.0000 Mhz +/- 2500 ppm only ESR max : 100 Ω	All product versions

USB Keyboard with Smart Card Reader Using AT83R5122, AT8xC5122/AT89C5122DS

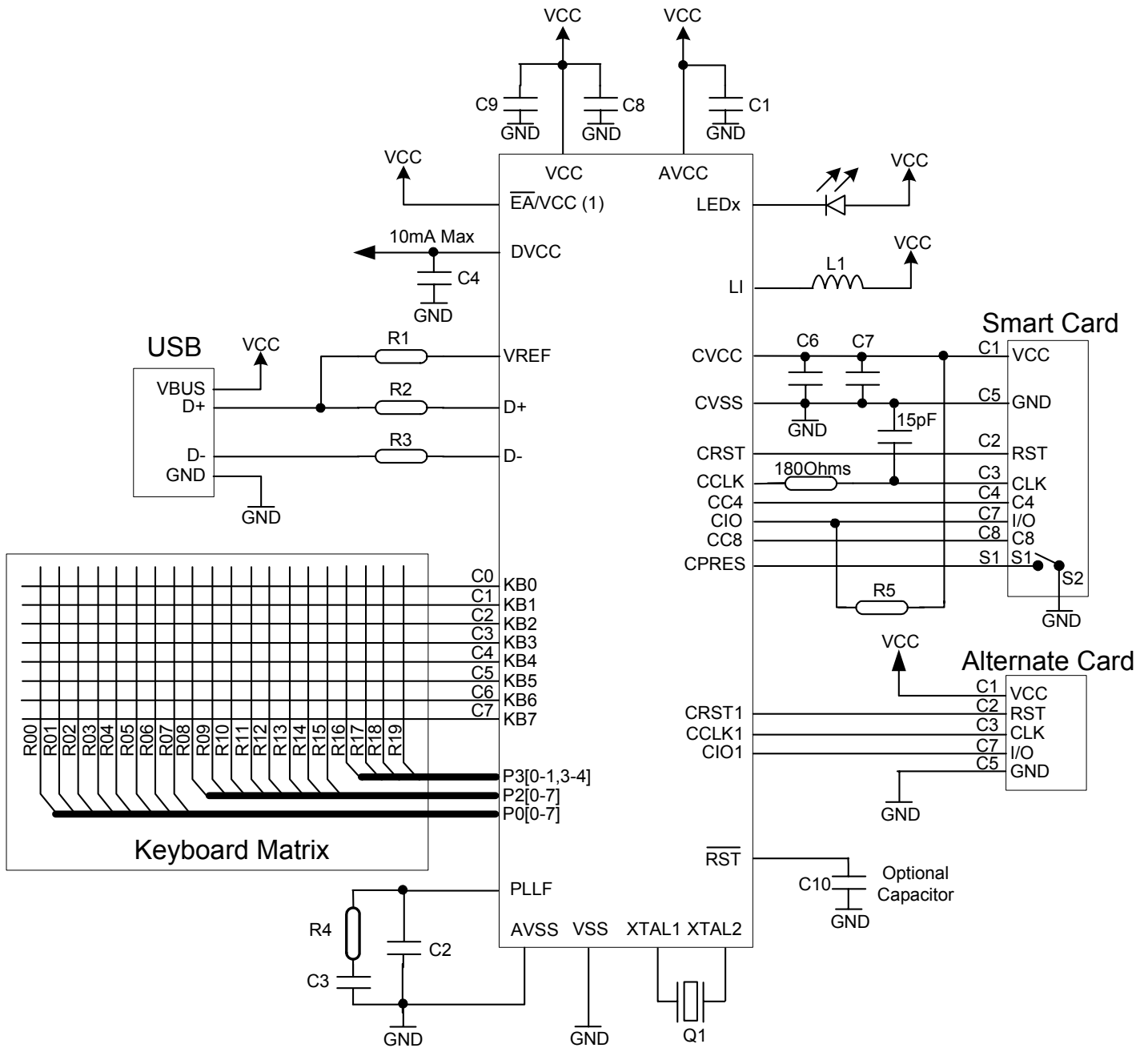

Notes :

1 - Pin configuration depends on product versions

USB Smart Card Reader Using the AT83C5123 Version

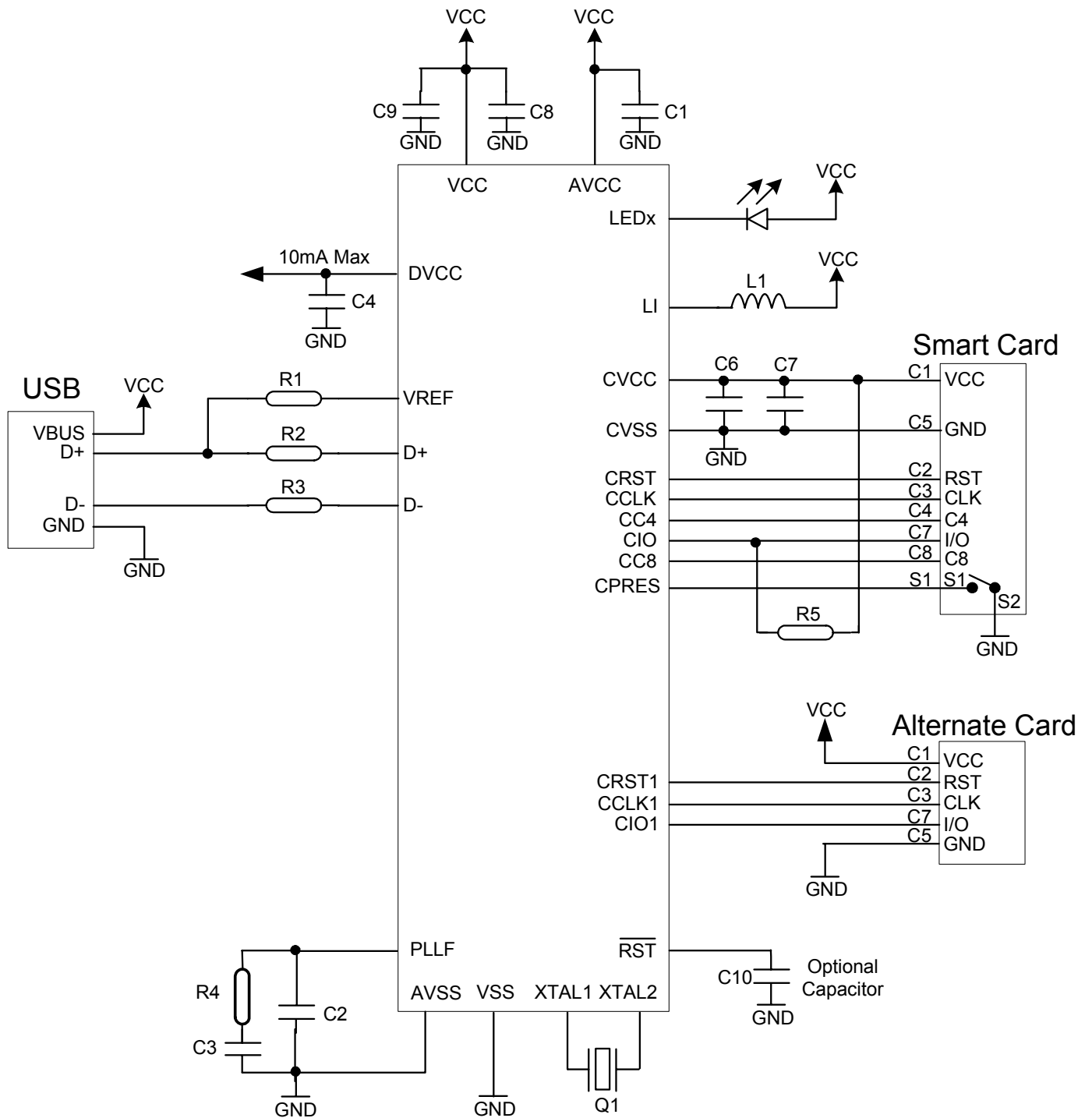

Memory Organization

The AT83R5122, AT8xC5122/23 devices have separated address spaces for Program and Data Memory, as shown in Figure 12 on page 27, Figure 13 on page 29 and Figure 14 on page 30. The logical separation of Program and Data memory allows the Data Memory to be accessed by 8-bit addresses, which can be more quickly stored and manipulated by an 8-bit CPU. Nevertheless, 16-bit Data Memory addresses can also be generated through the DPTR register.

Program Memory Management

Depending on the state of EA pin, the MCU fetches the code from internal or external program memory (ROMless mode)

Warning : the EA pin can not be left floating, otherwise MCU may have an unpredictable behaviour.

If EA is strapped to VCC, the MCU fetches the code from the internal program memory. The way the MCU works in this mode depends on the device version. See next paragraphs for further details.

If the EA is strapped to GND, the MCU fetches the code from external program memory. This mode is common for all device versions which supports it. After reset, the CPU begins the execution from location 0000h. There can be up to 64 KBytes of program memory. In this mode, the internal program memories are disabled.

The hardware configuration for external program execution is shown in Figure 8.

Figure 8. Executing from External Program Memory

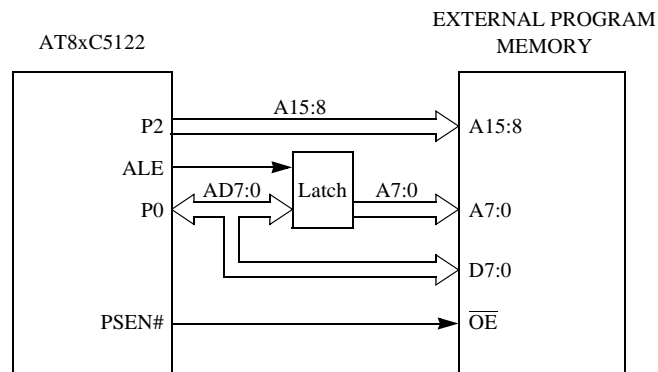

Note that the 16 I/O lines (Ports 0 and 2) are dedicated to bus functions during external Program Memory fetches. Port 0 serves as a multiplexed address/data bus. It emits the low byte of the Program Counter (PCL) as an address, and then goes into a float state awaiting the arrival of the code byte from the Program Memory. During the time that the low byte of the Program Counter is valid on P0, the signal ALE (Address Latch Enable) clocks the byte into an address latch. Meanwhile, Port 2 emits the high byte of the Program Counter (PCH). Then PSEN strobes the External Program Memory and the code byte is read into the MCU.

PSEN is not activated and Ports P0 and P2 are not affected during internal program fetches.

Data Memory Management

All device versions implements :

- 256 Bytes of RAM to increase data parameter handling and high level language usage
- 512 bytes of XRAM (Extended RAM) to store program data.

RAM Architecture

The internal RAM is mapped into three separate segments :

- The Lower 128 bytes (addresses 00h to 7Fh) are directly and indirectly addressable.
- The Upper 128 bytes (addresses 80h to FFh) are indirectly addressable only.
- The Special Function Registers (SFRs) (addresses 80h to FFh) are directly addressable only.

The Upper 128 bytes and SFR's have the same address space but are physically separated.

When an instruction accesses an internal location above address 7Fh, the CPU knows whether the access is in the upper 128 bytes of data RAM or to SFR space by the addressing mode used in the instruction.

- Instructions that use direct addressing access SFR space. For example: MOV 0A0H, # data, accesses the SFR at location 0A0h (which is P2).
- Instructions that use indirect addressing access the Upper 128 bytes of data RAM. For example: MOV @R0, # data where R0 contains 0A0h, accesses the data byte at address 0A0h, rather than P2 (whose address is 0A0h).

The stack pointer (SP) may be located anywhere in the 256 bytes RAM (lower and upper RAM) internal data memory. The stack may not be located in the XRAM.

The M0 bit allows to stretch the XRAM timings. If M0 is set, the read and write pulses are extended from 6 to 30 clock periods. This is useful to access external slow peripherals.

XRAM Architecture

Depending on the state of EXTRAM bit in AUXR register (See Table 5 on page 22), the MCU fetches data from internal or external XRAM.

If EXTRAM=0 (reset condition), the MCU fetches the data from internal XRAM. The size of internal XRAM is configured by the bit XRS0 in AUXR register (See Table 5 on page 22).

Table 4. XRAM Size Configuration

XRS0	XRAM size	Address	
		Start	End
0	256 Bytes (Reset condition)	000h	0FFh
1	512 bytes	000h	1FFh

The XRAM logically occupies the first bytes of external data memory. The bit XRS0 can be used to hide a part of the available XRAM . This can be useful if external peripherals are mapped at addresses already used by the internal XRAM.

The XRAM is indirectly addressed, using the MOVX instruction in combination with any of the registers R0, R1 of the selected bank or DPTR.

For example, MOVX @R0, # data where R0 contains 0A0H, accesses the XRAM at address 0A0H rather than external memory.

An access to external XRAM memory locations higher than the accessible size of the memory (roll-over feature) will be performed with the MOVX DPTR instructions, with P0 and P2 as data/address busses, WR and RD as respectively write and read signals. Accesses above XRAM size can only be done by the use of DPTR.

If EXTRAM=1 the MCU fetches the data from external XRAM Memory. There can be up to 64 KBytes of external XRAM Memory.

The hardware configuration for external Data Memory Access is shown in Figure 9

Figure 9. Accessing to External XRAM Memory

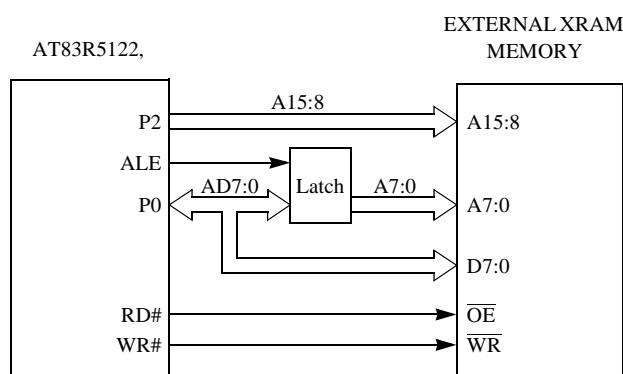

MOVX @Ri and MOVX @DPTR will be similar to the standard 80C51. MOVX @ Ri will provide an eight-bit address multiplexed with data on Port 0 and any output port pins can be used to output higher order address bits. This is to provide the external paging capability. MOVX @DPTR will generate a sixteen-bit address. Port 2 outputs the high-order eight address bits (DPH) while Port0 multiplexes the low-order eight address bits (DPL) with data. MOVX @ Ri and MOVX @DPTR will generate either read or write signals on WR and RD.

Ports P0, P2 are not affected and RD, WR signals are not activated during access to internal XRAM.

Note that external XRAM Memory access is only available on High Pin Count Packages.

External Program Memory and external XRAM Memory may be combined if desired by applying the RD and PSEN signals to the inputs of an AND gate and using the output of the gate as the read strobe to the external program/data memory.

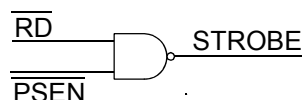

Dual Data Pointer Register (DDPTR)

The additional data pointer can be used to speed up code execution and reduce code size.

The dual DPTR structure is a way by which the chip will specify the address of an external data memory location. There are two 16-bit DPTR registers that address the external memory, and a single bit called DPS = AUXR1.0 (see Table 7) that allow the program code to switch between them (Figure 10).

Figure 10. Use of Dual Pointer

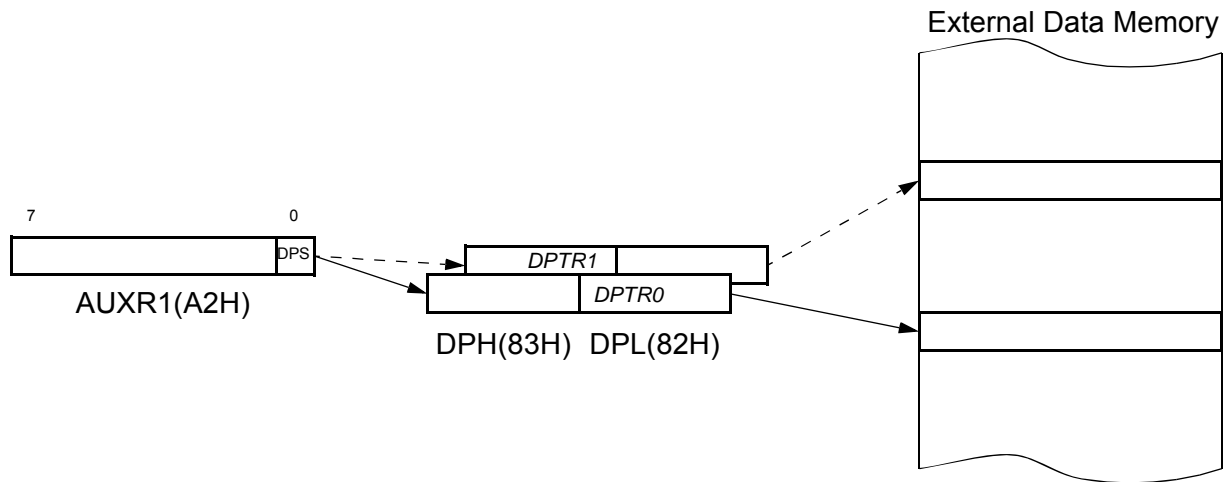

a. Bit 2 stuck at 0; this allows to use INC AUXR1 to toggle DPS without changing GF3.

Assembly Language

```

; Block move using dual data pointers
; Modifies DPTR0, DPTR1, A and PSW
; note: DPS exits opposite of entry state
; unless an extra INC AUXR1 is added
;
00A2  AUXR1  QU 0A2H
;
0000  909000MOV DPTR,#SOURCE ; address of SOURCE
0003  05A2  INC AUXR1 ; switch data pointers
0005  90A000 MOV DPTR,#DEST ; address of DEST
0008  LOOP:
0008  05A2  INC AUXR1 ; switch data pointers
000A  E0  MOVX A,@DPTR ; get a byte from SOURCE
000B  A3  INC DPTR ;increment SOURCE address
000C  05A2  INC AUXR1 ; switch data pointers
000E  F0  MOVX @DPTR,A ; write the byte to DEST
000F  A3  INC DPTR ; increment DEST address
0010  70F6JNZ LOOP ; check for 0 terminator
0012  05A2  INC AUXR1 ; (optional) restore DPS

```

INC is a short (2 bytes) and fast (12 clocks) way to manipulate the DPS bit in the AUXR1 SFR. However, note that the INC instruction does not directly force the DPS bit to a particular state, but simply toggles it. In simple routines, such as the block move example, only the fact that DPS is toggled in the proper sequence matters, not its actual value. For example, the block move routine works the same whether DPS is '0' or '1' on entry. Observe that without the last instruction (INC AUXR1), the routine will exit with DPS in the opposite state.

Registers

Table 5. Auxiliary Register - AUXR (8Eh)

7	6	5	4	3	2	1	0
DPU	-	-	-		XRS0	EXTRAM	AO

Bit Number	Bit Mnemonic	Description
7	DPU	Disable weak Pull-up 0 weak pull-up is enabled 1 weak pull-up is disabled
6-3	-	Reserved The value read from this bit is indeterminate. Do not change these bits.
2	XRS0	XRAM Size 0 256 bytes (default) 1 512 bytes
1	EXTRAM	EXTRAM bit Cleared to access internal XRAM using MOVX @ Ri/ @ DPTR. Set to access external memory. Programmed by hardware after Power-up regarding Hardware Security Byte (HSB), default setting , XRAM selected.
0	AO	ALE Output bit Cleared , ALE is emitted at a constant rate of 1/6 the oscillator frequency (or 1/3 if X2 mode is used)(default). Set , ALE is active only when a MOVX or MOVC instruction is used.

Reset Value = 0XXX X000b

Table 6. Auxiliary Register 1 AUXR1- (0A2h) for AT8xC5122

7	6	5	4	3	2	1	0
-	-	ENBOOT	-	GF3	0	-	DPS

Bit Number	Bit Mnemonic	Description
7 - 6	-	Reserved The value read from this bit is indeterminate. Do not change these bits.
5	ENBOOT	Enable Boot ROM (CRAM / E2PROM version only) Set this bit to map the Boot ROM from 8000h to FFFFh. If the PC increments beyond 7FFFh address, the code is fetch from internal ROM Clear this bit to disable Boot ROM. If the PC increments beyond 7FFFh address, the code is fetch from external code memory (C51 standard roll over function) This bit is forced to 1 at reset
4	-	Reserved The value read from this bit is indeterminate. Do not change this bit.
3	GF3	This bit is a general-purpose user flag.
2	0	Always cleared.
1	-	Reserved The value read from this bit is indeterminate. Do not change this bit.
0	DPS	Data Pointer Selection Cleared to select DPTR0. Set to select DPTR1.

Reset Value = XX1X XX0X0b (Not bit addressable)

Table 7. Auxiliary Register 1 AUXR1- (0A2h) for AT83C5123

7	6	5	4	3	2	1	0
-	-	-	-	GF3	0	-	DPS

Bit Number	Bit Mnemonic	Description
7 - 6	-	Reserved The value read from this bit is indeterminate. Do not change these bits.
5	-	Reserved The value read from this bit is indeterminate. Do not change these bits.
4	-	Reserved The value read from this bit is indeterminate. Do not change this bit.
3	GF3	This bit is a general-purpose user flag.
2	0	Always cleared.
1	-	Reserved The value read from this bit is indeterminate. Do not change this bit.
0	DPS	Data Pointer Selection Cleared to select DPTR0. Set to select DPTR1.

Reset Value = XXXX XX0X0b (Not bit addressable)





Table 8. CRAM Configuration Register - RCON (D1h)

7	6	5	4	3	2	1	0
-	-	-	-	RPS	-	-	-
Bit Number	Bit Mnemonic	Description					
7 - 4	-	Reserved The value read from this bit is indeterminate. Do not change these bits.					
3	RPS	CRAM Memory Mapping Bit Set to map the CRAM memory during MOVX instructions Clear to map the XRAM memory during MOVX. This bit has priority over the EXTRAM bit.					
2-0	-	Reserved The value read from this bit is indeterminate. Do not change these bits.					

Reset Value = XXXX 0XXXb

AT8xC5122's CRAM and E2PROM Versions

The AT8xC5122's CRAM and E2PROM versions implements :

- 32 KB of ROM mapped from 8000 to FFFF in which is embedded a bootloader for In-System Programming feature
- 32 KB of CRAM (Code RAM) , a volatile program memory mapped from 0000 to 7FFF

In CRAM versions only :

- 512 bytes of E2PROM can be optionally implemented to store permanent data

In E2PROM version :

- 32KB of E2PROM are implemented to store permanent code

Warnings :

- some bytes of user program memory space are reserved for bootloader configuration. Depending on the configuration, up to 256 bytes of code may be not available for the user code from 7F00h location. Refer to bootloader datasheet for further details.
- Port P3.7 may be used by the bootloader as a hardware condition at reset to select the In-System Programming mode. Once the bootloader has started, the P3.7 Port is no more used.

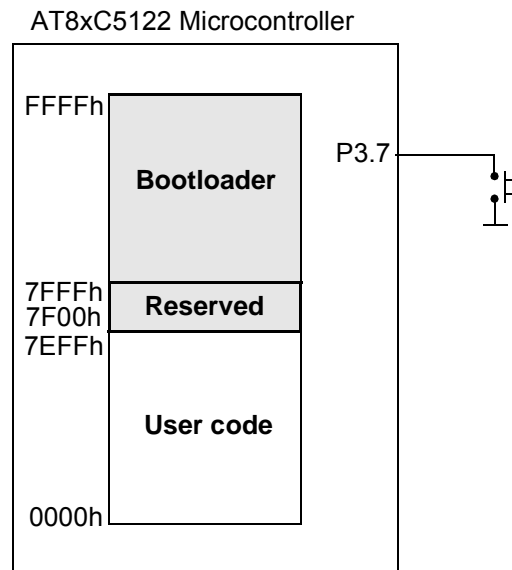

When pin EA =1 and after the reset, the MCU begins the execution of the embedded bootloader from location F800h of the ROM. The bootloader implements an In-System Programming (ISP) mode which manages the transfer of the code in the volatile Program Memory (CRAM).

For CRAM version, the code is supplied by the ATMEL's FLexible In-system Programming software (FLIP) through USB or UART interface

For E2PROM version, the code is supplied from the internal code E2PROM or by FLIP. The state of pin P3.7 at reset determines the code source. If P3.7=1 (reset condition) the source is the internal E2PROM and the transfer takes about 1.5 seconds. If P3.7=0 the source is FLIP and the transfer time depends mainly on external conditions not related to bootloader.

Once the code is running in CRAM, the roll-over condition (code fetched beyond address 7FFFh) depends on the state of ENBOOT bit of AUXR1 register (Table 6 on page 23).

If ENBOOT=1 (reset condition) the MCU fetches the code from bootloader ROM. If ENBOOT=0, the MCU fetches the code from the external Program Memory. In this last case, PSEN is activated and Ports P0 and P2 are used to emit data and address signals.

Warning : external Program Memory access is not allowed on Low Pin Count Packages.

Using CRAM Memory

The CRAM is a read / write volatile memory that is mapped in the program memory space. Then when the power is switched off the code is lost and needs to be reloaded at each power up. In return, the CRAM enables a lot of flexibility in the code development as it can be programmed indefinitely. The user code running in the CRAM can perform read operations in CRAM itself by means of MOVC instructions like any C51 microcontroller does. Although the writing operations in CRAM are usually handled by the bootloader, it is possible for the user code to handle its own writing operations in CRAM as well. The user code must call API functions provided by the bootloader in the ROM memory. Refer to bootloader datasheet for further details about the use of these API functions. These API functions use a mechanism provided by the AT8xC5122 microcontroller. When the bit RPS is set in RCON register (Table 8 on page 24), the MOVX instructions are configured to write in CRAM instead of XRAM memory. However, due to C51 architecture, it is not possible for the user code to write directly in CRAM when it is itself running in CRAM. This is why the API functions must be called in order to have the code executing in ROM while the CRAM is written.

Figure 11. Read / Write Mechanisms in CRAM Memory

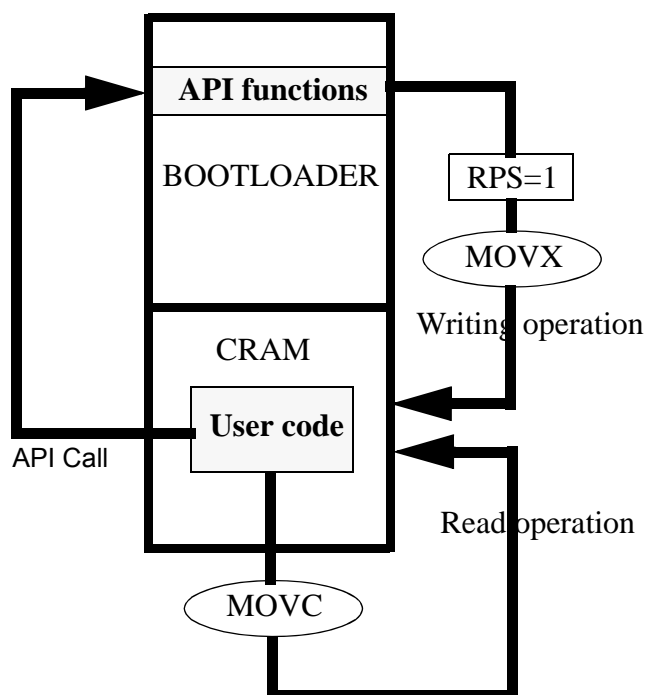
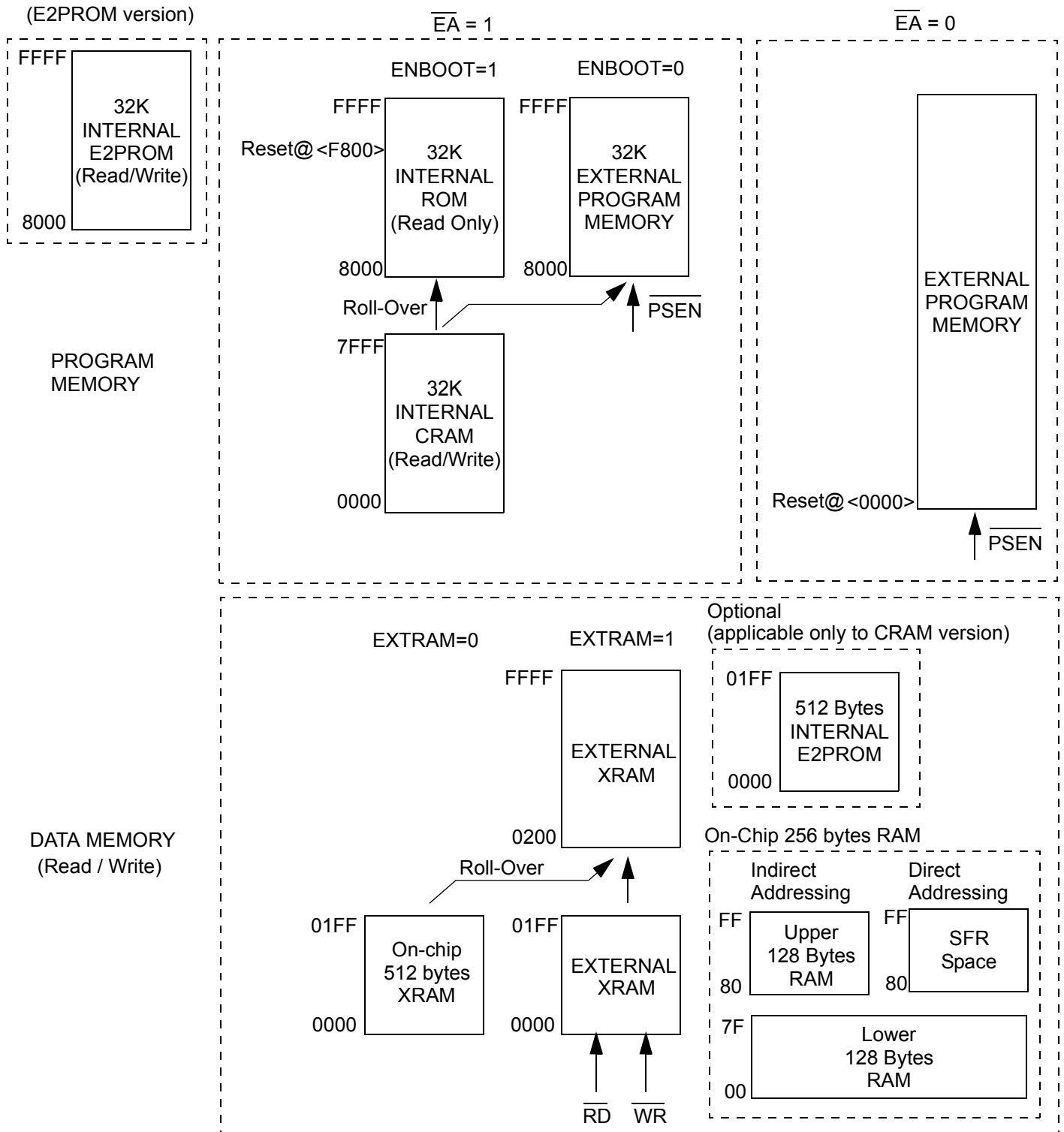

Figure 12. AT8xC5122's CRAM and E2PROM Versions





AT83R5122, AT8xC5122's ROM Version

The AT83R5122, AT8xC5122's ROM version implements :

- 32 K of ROM mapped from 0000h to 7FFFh in which is embedded the user code. The ROM device is only factory programmable.

- 512 bytes of E2PROM can be optionally implemented to store permanent data. With this option, the size of ROM is reduced to 30K.

After the reset, the MCU begins the execution of the user code from location 0000h of the ROM.

Access to external Program Memory is not allowed.

Security Level

There are two security levels (applicable to High Pin Count packages only) :

Table 9. Security Levels Description

Security Level	Protection description
1	No protection lock enabled
2	MOVC instruction executed from external Program Memory is disabled when fetching code bytes from internal Program Memory \overline{EA} is sampled and latched on reset. External code execution is enabled.

The security level 2 can be used to protect the user code from piracy. This option is configured at factory and must be requested by the customer at order time.

Figure 13. AT83R5122, AT8xC5122's ROM Version

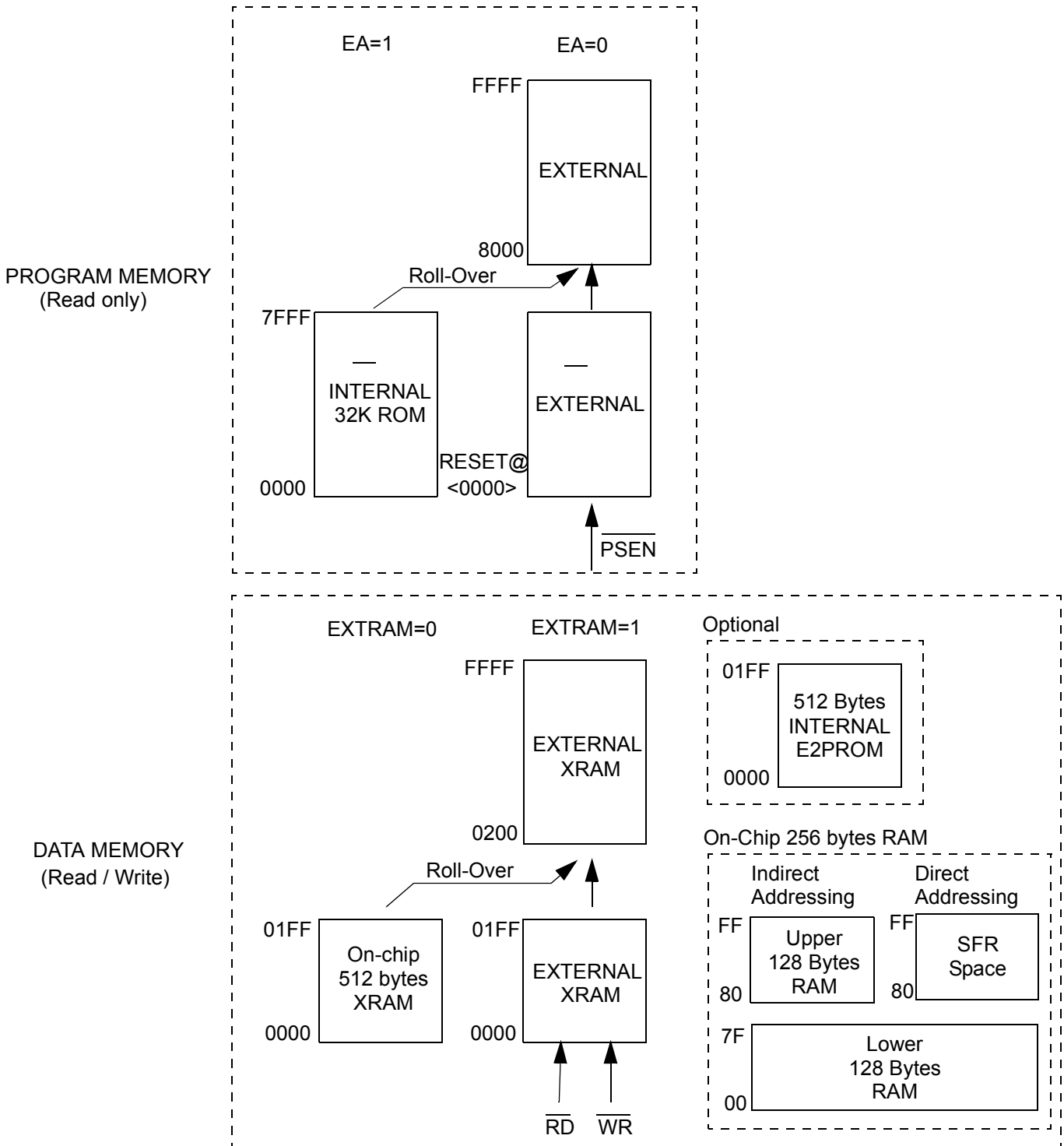

AT83C5123 Version

The AT83C5123 device is a low pin count version of the AT8xC5122.

The ROM version implements :

- 30 KB of ROM mapped from 0000 to 7FFF in which is embedded the user code. The ROM device is only factory programmable.
- 512 bytes of E2PROM can be optionally implemented to store permanent data

Figure 14. AT83C5123's Device

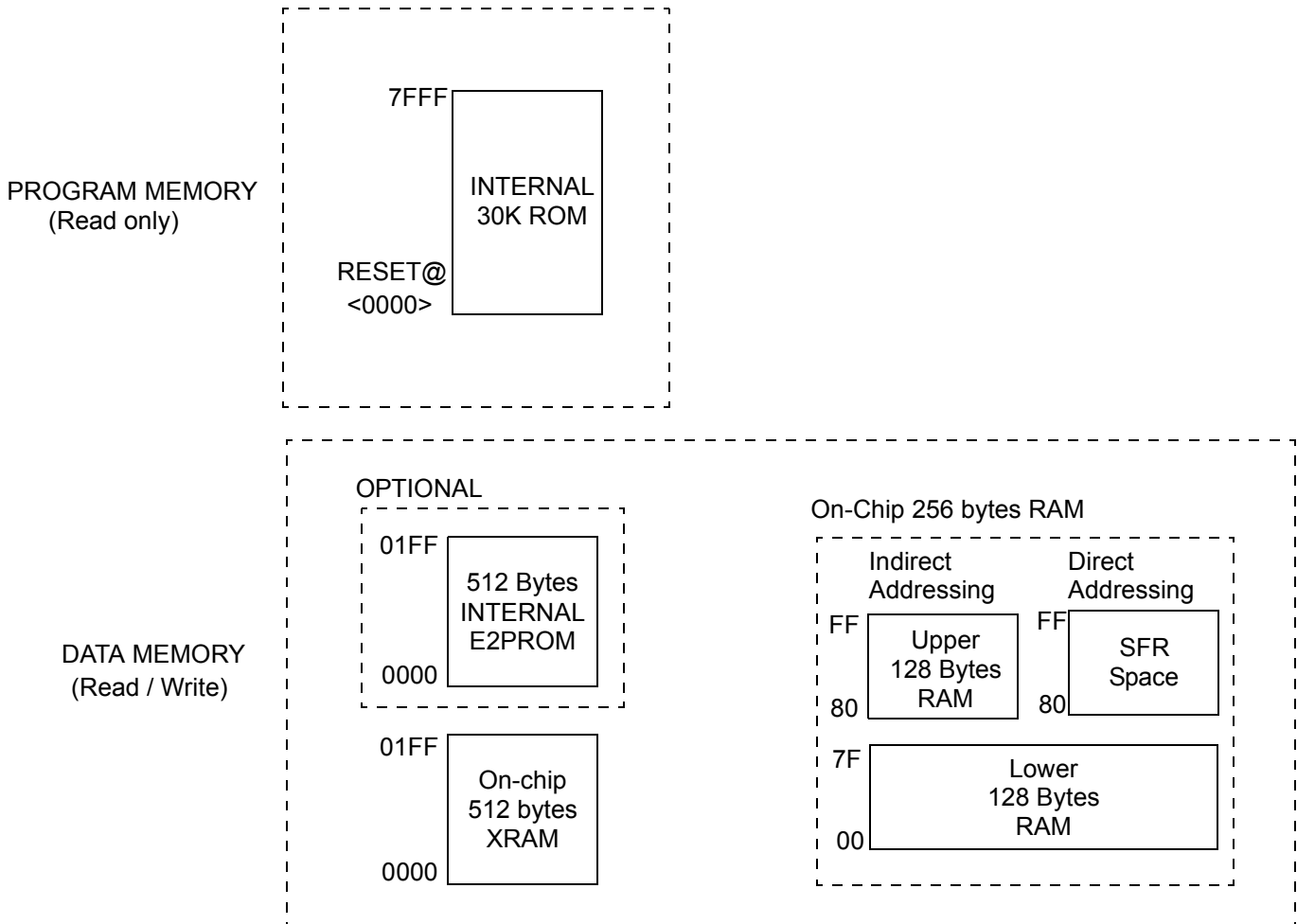

Special Function Registers (SFR's)

Introduction

The Special Function Registers (SFRs) of the AT8xC5122/23 can be ranked into the following categories:

- C51 Core Registers: ACC, B, DPH, DPL, PSW, SP
- System Configuration Registers: PCON, CKRL, CKCON0, CKCON1, CKSEL, PLLCON, PLLDIV, AUXR, AUXR1, RCON
- I/O Port Registers: P0, P1, P2, P3, P4, P5, PMOD1, PMOD2
- Timer Registers: TCON, TH0, TH1, TMOD, TL0, TL1
- Watchdog (WD) Registers: WDTRST, WDTPRG
- Serial I/O Port Registers: SADDR, SADEN, SBUF, SCON
- Baud Rate Generator (BRG) Registers: BRL, BDRCON
- System Interrupt Registers: IE0, IPL0, IPH0, IE1, IPL1, IPH1
- Smart Card Interface (SCI) Registers: SCSR, SCCON/SCETU0, SCISR/SCETU1, SCIER/SCIIR, SCIBUF, SCGT0/SCWT0, SCGT1/SCWT1, SCICR/SCWT2, SCICLK
- DC/DC Converter Registers: DCCKPS
- Keyboard Interface Registers: KBE, KBF, KBL5
- Serial Port Interface (SPI) Registers: SPCON, SPSTA, SPDAT
- Universal Serial Bus (USB) Registers: USBCON, USBADDR, USBINT, USBIEN, UEPNUM, UEPCONX, UEPSTAX, UEPRST, UEPINT, UEPIEN, UEPDATX, UBYCTX, UFNUML, UFNUMH
- LED Controller Registers: LEDCON0, LEDCON1



AT8x5122 Version

		Bit addressable	Not bit addressable							
		0/8	1/9	2/A	3/B	4/C	5/D	6/E	7/F	
F8h		UEPINT 0000 0000								
F0h		B 0000 0000	LEDCON0 0000 0000							
E8h		P5 1111 1111								
E0h		ACC 0000 0000	LEDCON1 XX00 0000	UBYCTX 0000 0000						
D8h										
D0h		PSW 0000 0000	RCON XXXX 0XXX			UEPCONX 1000 0000	UEPRST 0000 0000			
C8h								UEPSTAX 0000 0000	UEPDATX 0000 0000	
S C R S	1	C0h	P4 1111 1111	SCICLK ⁽¹⁾ 0X10 1111	UEPIEN 0000 0000	SPCON 0001 0100	SPSTA 0000 0000	SPDAT 1111 1111	USBADDR 1000 0000	UEPNUM 0000 0000
	0			SCWT3 ⁽¹⁾ 0000 0000						
B8h		IPL0 X000 000	SADEN 0000 0000	UFNUML 0000 0000	UFNUMH 0000 0000	USBCON 0000 0000	USBINT 0000 0000	USBIEIN 0000 0000	DCCKPS 0000 0000	
S C R S	1	B0h	P3 1111 1111	IEN1 XXXX X000	IPL1 00XX 00X0	IPH1 00XX 00X0	SCGT0 ⁽¹⁾ 0000 1100	SCGT1 ⁽¹⁾ XXXX XXX0	SCICR ⁽¹⁾ 0000 0000	IPH0 X000 0000
	0						SCWT0 ⁽¹⁾ 1000 0000	SCWT1 ⁽¹⁾ 0010 0101	SCWT2 ⁽¹⁾ 0000 0000	
S C R S	1	A8h	IEN0 0000 0000	SADDR 0000 0000	SCIBUF XXXX XXXX	SCSR X000 1000	SCETU0 ⁽¹⁾ 0111 0100	SCETU1 ⁽¹⁾ XXXX X001	SCIER ⁽¹⁾ 0X00 0000	
	0						SCCON ⁽¹⁾ 0000 0000	SCISR ⁽¹⁾ 10X0 0000	SCIIR ⁽¹⁾ 0X00 0000	
A0h		P2 1111 1111	ISEL 0000 0100	AUXR1 XX1X 0XX0	PLLCON XXXX X000	PLLDIV 0000 0000		WDTRST XXXX XXXX	WDTPRG XXXX X000	
98h		SCON 0000 0000	SBUF XXXX XXXX	BRL 0000 0000	BDRCON XXX0 0000	KBLS 0000 0000	KBE 0000 0000	KBF 0000 0000		
90h		P1 1111 1111	PMOD0 ⁽²⁾ 0000 0000						CKRL XXXX 1111	
88h		TCON 0000 0000	TMOD 0000 0000	TL0 0000 0000	TL1 0000 0000	TH0 0000 0000	TH1 0000 0000	AUXR 0XXX X000	CKCON0 X0X0 X000	
80h		P0 1111 1111	SP 0000 0111	DPL 0000 0000	DPH 0000 0000	PMOD1 0000 0000	CKSEL XXXX XXX0		PCON 00X1 0000	

Notes: 1. Mapping is done using SCRS bit in SCSR register.
2. Grey areas : do not write in.

AT83C5123 Version

		Bit addressable	Not bit addressable							
		0/8	1/9	2/A	3/B	4/C	5/D	6/E	7/F	
F8h		UEPINT 0000 0000								
F0h		B 0000 0000	LEDCON0 0000 0000							
E8h		P5 XXXX XXX1								
E0h		ACC 0000 0000		UBYCTX 0000 0000						
D8h										
D0h		PSW 0000 0000				UEPCONX 1000 0000	UEPRST 0000 0000			
C8h								UEPSTAX 0000 0000	UEPDATX 0000 0000	
S C R S	1	C0h	P4 11XX XXXX	SCICLK ⁽¹⁾ 0X10 1111	UEPIEN 0000 0000				USBADDR 1000 0000	UEPNUM 0000 0000
	0			SCWT3 ⁽¹⁾ 0000 0000						
B8h		IPL0 X000 000	SADEN 0000 0000	UFNUML 0000 0000	UFNUMH 0000 0000	USBCON 0000 0000	USBINT 0000 0000	USBIEN 0000 0000	DCCKPS 0000 0000	
S C R S	1	B0h	P3 1111 1111	IEN1 X0XX 0XXX	IPL1 X0XX 0XXX	IPH1 X0XX 0XXX	SCGT0 ⁽¹⁾ 0000 1100	SCGT1 ⁽¹⁾ XXXX XXX0	SCICR ⁽¹⁾ 0000 0000	IPH0 X000 0000
	0						SCWT0 ⁽¹⁾ 1000 0000	SCWT1 ⁽¹⁾ 0010 0101	SCWT2 ⁽¹⁾ 0000 0000	
S C R S	1	A8h	IEN0 0000 0000	SADDR 0000 0000	SCIBUF XXXX XXXX	SCSR X000 1000	SCETU0 ⁽¹⁾ 0111 0100	SCETU1 ⁽¹⁾ XXXX X001	SCIER ⁽¹⁾ 0X00 0000	CKCON1 XXXX XXX0
	0						SCCON ⁽¹⁾ 0000 0000	SCISR ⁽¹⁾ 10X0 0000	SCIIR ⁽¹⁾ 0X00 0000	
A0h			ISEL 0000 0100	AUXR1 XXXX 0XX0	PLLCON XXXX X000	PLLDIV 0000 0000		WDTRST XXXX XXXX	WDTPRG XXXX X000	
98h		SCON 0000 0000	SBUF XXXX XXXX	BRL 0000 0000	BDRCON XXX0 0000					
90h		P1 1111 1111	PMOD0 00XX 0XXX						CKRL XXXX 1111	
88h		TCON 0000 0000	TMOD 0000 0000	TL0 0000 0000	TL1 0000 0000	TH0 0000 0000	TH1 0000 0000	AUXR 0XXX X000	CKCON0 X0X0 X000	
80h			SP 0000 0111	DPL 0000 0000	DPH 0000 0000	PMOD1 XXXX 00XX	CKSEL XXXX XXX0		PCON 00X1 0000	

Notes: 1. Mapping is done using SCRS bit in SCSR register.
2. Grey areas : do not write in.



SFR's Description

Table 10. C51 Core SFRs

Mnemonic	Add	Name	7	6	5	4	3	2	1	0
ACC	E0h	Accumulator	ACC							
B	F0h	B Register	B							
PSW	D0h	Program Status Word	CY	AC	F0	RS1	RS0	OV	F1	P
SP	81h	Stack Pointer	SP							
DPL	82h	Data Pointer Low byte (LSB of DPTR)	DPL							
DPH	83h	Data Pointer High byte (MSB of DPTR)	DPH							

Table 11. Clock SFRs

Mnemonic	Add	Name	7	6	5	4	3	2	1	0
PCON	87h	Power Controller	SMOD1	SMOD0		POF	GF1	GF0	PD	IDL
CKCON0	8Fh	Clock Controller 0		WDX2		SIX2		T1X2	T0X2	X2
CKCON1	AFh	Clock Controller 1								SPIX2
CKSEL	85h	Clock Selection								CKS
CKRL	97h	Clock Reload Register					CKREL 3-0			
PLLCON	A3h	PLL Controller Register						EXT48	PLLEN	PLOCK
PLLDIV	A4h	PLL Divider register	R3-0				N3-0			
AUXR	8Eh	Auxiliary Register 0	DPU					XRS0	EXTRAM	A0
AUXR1	A2h	Auxiliary Register 1			ENBOOT ⁽¹⁾		GF3			DPS
RCON ⁽¹⁾	D1h	CRAM memory Configuration					RPS			

Note: 1. Only for AT8xC5122

Table 12. I/O Port SFRs

Mnemonic	Add	Name	7	6	5	4	3	2	1	0
P0 ⁽¹⁾	80h	Port 0	P0							
P1	90h	Port 1	P1							
P2 ⁽¹⁾	A0h	Port 2	P2							
P3	B0h	Port 3	P3							
P4 ⁽¹⁾	C0h	Port 4	P4							
P5	E8h	Port 5	P5 (only P5.0 for AT8xC5122)							
PMOD0	91h	Port Mode Register 0	P3C1	P3C0	P2C1 ⁽¹⁾	P2C0 ⁽¹⁾	CPRESRES	-	P0C1 ⁽¹⁾	P0C0 ⁽¹⁾
PMOD1	84h	Port Mode Register 1	P5HC1 ⁽¹⁾	P5HC0 ⁽¹⁾	P5MC1 ⁽¹⁾	P5MC0 ⁽¹⁾	P5LC1	P5LC0	P4C1 ⁽¹⁾	P4C0 ⁽¹⁾

Note: 1. Only for AT8xC5122

Table 13. Timers SFRs

Mnemonic	Add	Name	7	6	5	4	3	2	1	0
TH0	8Ch	Timer/Counter 0 High byte	TH0							
TL0	8Ah	Timer/Counter 0 Low byte	TL0							
TH1	8Dh	Timer/Counter 1 High byte	TH1							
TL1	8Bh	Timer/Counter 1 Low byte	TL1							
TCON	88h	Timer/Counter 0 and 1 control	TF1	TR1	TF0	TR0	IE1	IT1	IE0	IT0
TMOD	89h	Timer/Counter 0 and 1 Modes	GATE1	C/T1#	M11	M01	GATE0	C/T0#	M10	M00

Table 14. Watchdog SFRs

Mnemonic	Add	Name	7	6	5	4	3	2	1	0
WDTRST	A6h	Watchdog Timer Reset	WDTRST							
WDTPRG	A7h	Watchdog Timer Program							S2-0	

Table 15. Serial I/O Ports SFRs

Mnemonic	Add	Name	7	6	5	4	3	2	1	0
SCON	98h	Serial Control	FE/SM0	SM1	SM2	REN	TB8	RB8	TI	RI
SBUF	99h	Serial Data Buffer	SBUF							
SADEN	B9h	Slave Address Mask	SADEN							
SADDR	A9h	Slave Address	SADDR							

Table 16. Baud Rate Generator SFRs

Mnemonic	Add	Name	7	6	5	4	3	2	1	0
BRL	9Ah	Baud Rate Reload	BRL							
BDRCON	9Bh	Baud Rate Control				BRR	TBCK	RBCK	SPD	M0SRC

Table 17. Interrupt SFRs

Mnemonic	Add	Name	7	6	5	4	3	2	1	0
IEN0	A8h	Interrupt Enable Control 0	EA			ES	ET1	EX1	ET0	EX0
IEN1	B1h	Interrupt Enable Control 1		EUSB			ESCI	ESPI ⁽¹⁾		EKB ⁽¹⁾
IPL0	B8h	Interrupt Priority Control Low 0				PSL	PT1L	PX1L	PT0L	PX0L



Table 17. Interrupt SFRs

Mnemonic	Add	Name	7	6	5	4	3	2	1	0
IPH0	B7h	Interrupt Priority Control High 0				PSH	PT1H	PX1H	PT0H	PX0H
IPL1	B2h	Interrupt Priority Control Low 1		PUSBL			PSCIL	PSPIL ⁽¹⁾		PKBL ⁽¹⁾
IPH1	B3h	Interrupt Priority Control High 1		PUSBH			PSCIH	PSPIH ⁽¹⁾		PKBH ⁽¹⁾
ISEL	A1h	Interrupt Enable Register	CPLEV		PRESIT	RXIT	OELEV	OEEN	PRESEN	RXEN

Note: 1. Only for AT8xC5122

Table 18. SCIB SFRs

Mnemonic	Add	Name	7	6	5	4	3	2	1	0
SCGT0	B4h	Smart Card Transmit Guard Time Register 0	GT7 - 0							
SCGT1	B5h	Smart Card Transmit Guard Time Register 1								GT8
SCWT0	B4h	Smart Card Character/ Block Waiting Time Register 0	WT7 - 0							
SCWT1	B5h	Smart Card Character/ Block Waiting Time Register 1	WT15-8							
SCWT2	B6h	Smart Card Character/ Block Waiting Time Register 2	WT23-16							
SCWT3	C1h	Smart Card Character/ Block Waiting Time Register 3	WT31-24							
SCICR	B6h	Smart Card Interface Control Register	RESET	CARDET	VCARD1-0		UART	WTEN	CREP	CONV
SCCON	ACh	Smart Card Interface Contacts Register	CLK		CARDC8	CARDC4	CARDIO	CARDCLK	CARDRST	CARDVCC
SCETU0	ACh	Smart Card ETU Register 0	ETU7 - 0							
SCETU1	ADh	Smart Card ETU Register 1	COMP					ETU10-8		
SCISR	ADh	Smart Card UART Interface Status Register (Read only)	SCTBE	CARDIN	ICARDOVF	VCARDOK	SCWTO	SCTC	SCRC	SCPE
SCIIR	A Eh	Smart Card UART Interrupt Identification Register (Read only)	SCTBI		ICARDERR	VCARDERR	SCWTI	SCTI	SCRI	SCPI
SCIER	A Eh	Smart Card UART Interrupt Enable Register	ESCTBI		ICARDER	EVCARDER	ESCWTI	ESCTI	ESCRI	ESCPI
SCSR	ABh	Smart Card Selection Register		BGTEN		CREPSEL	ALTKPS1-0		SCCLK1	SCRS
SCIBUF	AAh	Smart Card Buffer Register	Can store a new byte to be transmitted on the I/O pin when SCTBE is set. Bit ordering on the I/O pin depends on the convention Provides the byte received from the I/O pin when SCRI is set. Bit ordering on the I/O pin depends on the convention.							

Table 18. SCIB SFRs

Mnemonic	Add	Name	7	6	5	4	3	2	1	0
SCICLK	C1h	Smart Card Frequency Prescaler Register	XTSCS ⁽¹⁾		SCICLK5-0					

Note: 1. Only for AT8xC5122

Table 19. DC/DC SFRs

Mnemonic	Add	Name	7	6	5	4	3	2	1	0
DCCKPS	BfH	DC/DC Converter Reload Register	MODE	OVFADJ	BOOST[1-0]		DCCKPS3-0			

Table 20. Keyboard SFRs

Mnemonic	Add	Name	7	6	5	4	3	2	1	0
KBF ⁽¹⁾	9Eh	Keyboard Flag Register	KBE7 - 0							
KBE ⁽¹⁾	9Dh	Keyboard Input Enable Register	KBF7 - 0							
KBLS ⁽¹⁾	9Ch	Keyboard Level Selector Register	KBLS7 - 0							

Note: 1. Only for AT8xC5122

Table 21. SPI SFRs

Mnemonic	Add	Name	7	6	5	4	3	2	1	0
SPCON ⁽¹⁾	C3h	Serial Peripheral Control	SPR2	SPEN	SSDIS	MSTR	CPOL	CPHA	SPR1	SPR0
SPSTA ⁽¹⁾	C4h	Serial Peripheral Status-Control	SPIF	WCOL		MODF				
SPDAT ⁽¹⁾	C5h	Serial Peripheral Data	R7 - 0							

Notes: 1. Only for AT8xC5122

Table 22. USB SFRs

Mnemonic	Add	Name	7	6	5	4	3	2	1	0
USBCON	BCh	USB Global Control	USBE	SUSPCLK	SDRMWUP	DETACH	UPRSM	RMWUPE	CONFIG	FADDEN
USBADDR	C6h	USB Address	FEN	UADD6-0						
USBINT	BDh	USB Global Interrupt			WUPCPU	EORINT	SOFINT			SPINT
USBIEN	BEh	USB Global Interrupt Enable			EWUPCPU	EEORINT	ESOFINT			ESPINT
UEPNUM	C7h	USB Endpoint Number					EPNUM3-0			
UEPCONX	D4h	USB Endpoint X Control	EPEN	NAKIEN	NAKOUT	NAKIN	DTGL	EPDIR	EPTYPE1	EPTYPE0
UEPSTAX	CEh	USB Endpoint X Status	DIR	RXOUTB1	STALLRQ	TXRDY	STL/CRC	RXSETUP	RXOUTB0	TXCMP
UEPRST	D5h	USB Endpoint Reset		EP6RST	EP5RST	EP4RST	EP3RST	EP2RST	EP1RST	EP0RST
UEPINT	F8h	USB Endpoint Interrupt		EP6INT	EP5INT	EP4INT	EP3INT	EP2INT	EP1INT	EP0INT



Table 22. USB SFRs

Mnemonic	Add	Name	7	6	5	4	3	2	1	0
UEPIEN	C2h	USB Endpoint Interrupt Enable		EP6INTE	EP5INTE	EP4INTE	EP3INTE	EP2INTE	EP1INTE	EP0INTE
UEPDATA	CFh	USB Endpoint X Fifo Data	FDAT7 - 0							
UBYCTX	E2h	USB Byte Counter Low (EPX)		BYCT6-0						
UFNUML	BAh	USB Frame Number Low	FNUM7 - 0							
UFNUMH	BBh	USB Frame Number High			CRCOK	CRCERR		FNUM10-8		

Table 23. LED SFRs

Mnemonic	Add	Name	7	6	5	4	3	2	1	0
LEDCON0	F1h	LED Control 0	LED3		LED2		LED1		LED0	
LEDCON1 ⁽¹⁾	E1h	LED Control 1			LED6		LED5		LED4	

Note: 1. Only for AT8xC5122

Clock Controller

The clock controller is based on an on-chip oscillator feeding an on-chip Phase Lock Loop (PLL). All the internal clocks to the CPU core and peripherals are generated by this controller.

On-Chip Oscillator

The on-chip oscillator is composed of a single-stage inverter and a parallel feedback resistor. The XTAL1 and XTAL2 pins are respectively the input and the output of the inverter, which can be configured with off-chip components as a Pierce oscillator (see Figure 15).

The on-chip oscillator has been designed and optimized to work with an external 8 MHz crystal and very few load capacitance. Then external load capacitors are not needed given that :

- the internal capacitance of the microcontroller and the stray capacitance of circuit board are enough to ensure a stable oscillation
- a very high accuracy on the oscillation frequency is not needed

The circuit works on its fundamental frequency at 8 MHz.

Figure 15. Oscillator Schematic

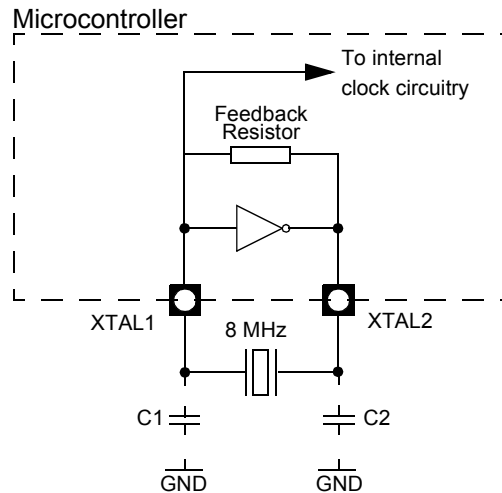

C1 and C2 represents the internal capacitance of the microcontroller and the stray capacitance of the circuit board. It is recommended to implement the crystal as close as possible from the microcontroller package.

Quartz Specification

The equivalent circuit of a crystal is represented on the figure below :

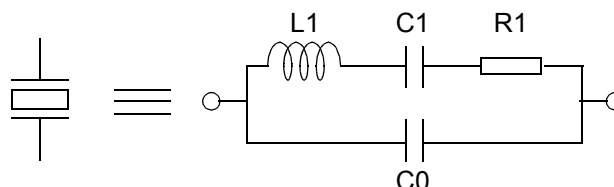

The Equivalent Serial Resistance R1 must be lower than 100 Ohm with a tolerance of +/- 2500 ppm only.

Phase Lock Loop (PLL)

PLL Description

The AT83R5122, AT8xC5122/23's PLL is used to generate internal high frequency clock synchronized with an external low-frequency. Figure 16 shows the internal structure of the PLL.

The PFLD block is the Phase Frequency Comparator and Lock Detector. This block makes the comparison between the reference clock coming from the N divider and the reverse clock coming from the R divider and generates some pulses on the Up or Down signal depending on the edge position of the reverse clock. The PLEN bit in PLLCON register is used to enable the clock generation. When the PLL is locked, the bit PLOCK in PLLCON register is set.

The CHP block is the Charge Pump that generates the voltage reference for the VCO by injecting or extracting charges from the external filter connected on PLLF pin (see Figure 17). Value of the filter components are detailed in the Section "DC Characteristics".

The VCO block is the Voltage Controlled Oscillator controlled by the voltage V_{REF} produced by the charge pump. It generates a square wave signal: the PLL clock. The CK_PLL frequency is defined by the following formula:

$$F_{CK_PLL} = F_{CK_XTAL1} * (R+1) / (N+1)$$

Figure 16. PLL Block Diagram and Symbol

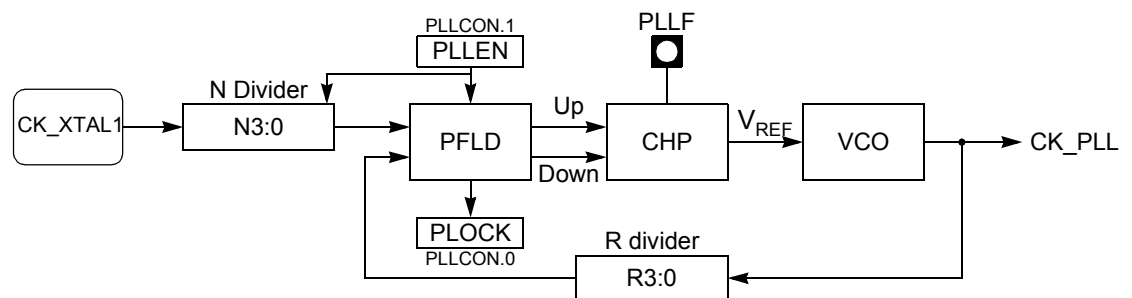
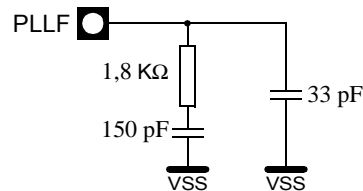

Figure 17. PLL Filter Value



PLL Programming

The PLL must be programmed to work at 96 MHz frequency by means of PLLCON and PLLDIV registers. As soon as the PLL is enabled, the firmware must wait for the lock bit status to ensure that the PLL is ready.

Figure 18. PLL Programming Flow

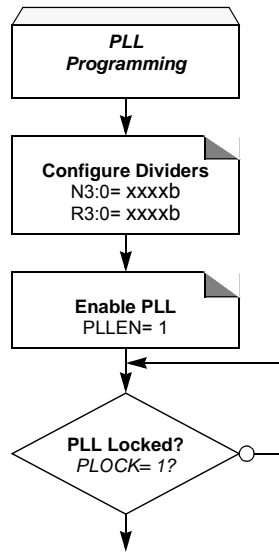

Clock Tree Architecture

The clock controller outputs several different clocks as shown in Figure 19:

- a clock for the CPU core
- a clock for the peripherals which is used to generate the timers, watchdog, SPI, UART, and ports sampling clocks. This divided clock will be used to generate the alternate card clock.
- a clock for the USB
- a clock for the SCIB controller
- a clock for the DC/DC converter

These clocks are enabled or not depending on the power reduction mode as detailed in Section "Power Management", page 178.

These clocks are generated using four prescalers defined in the table below:

Prescaler	Register	Reload Factor	Function
PR1	CKRL	CKRL[0:3]	CPU & Peripheral clocks
PR2	SCICLK	SCICLK[0:5]	Smart card
PR3	SCSR	ALTKPS[0:1]	Alternate card
PR4	DCCKPS	DCCKPS[3:0]	DC/DC

Figure 19. Clock Tree Diagram

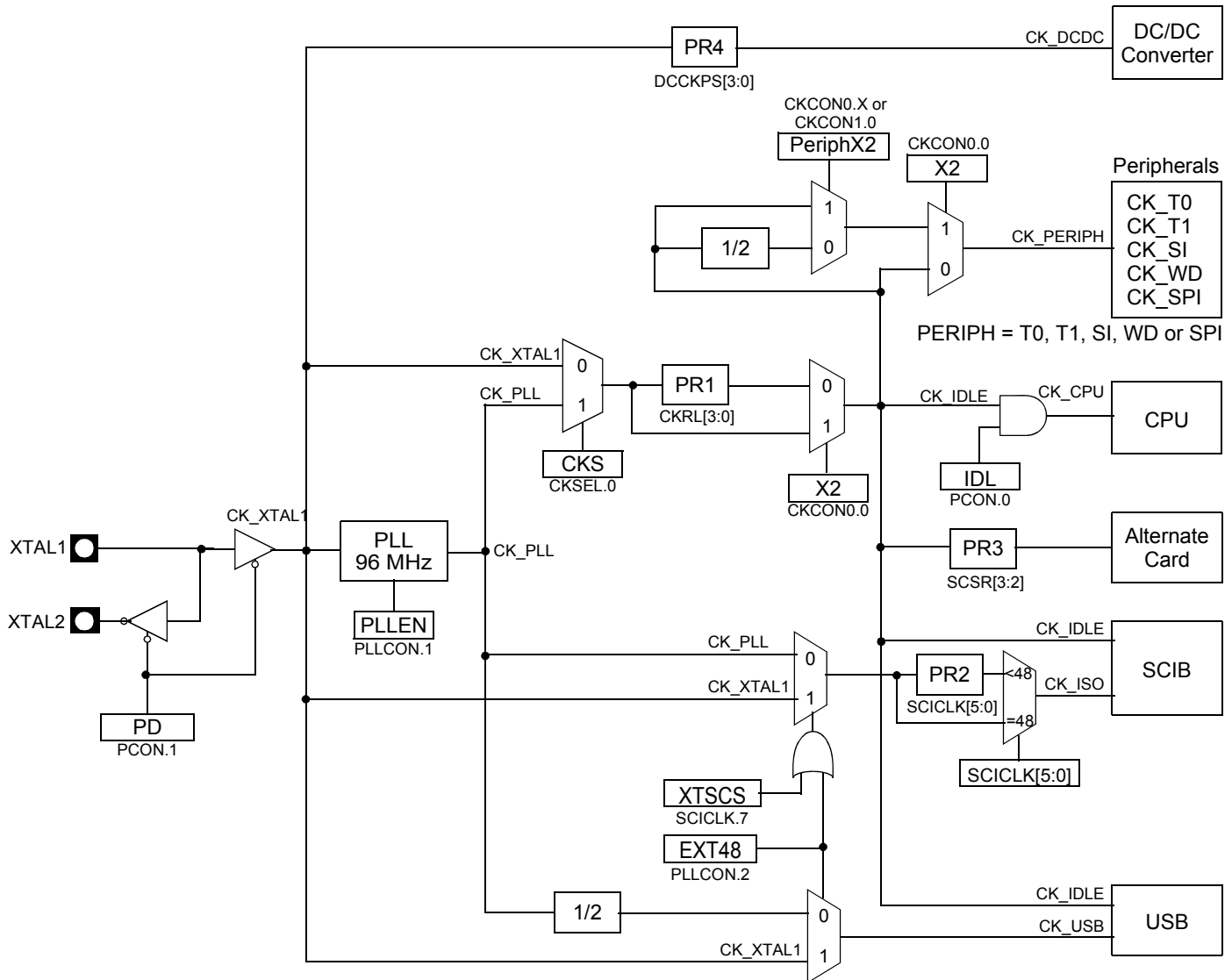

CPU and Peripheral Clocks

Two clocks sources are available for CPU and peripherals:

- on-chip oscillator
- a derivative of the PLL clock.

These clock sources are configured by the PR1 prescaler to generate the CPU core CK_CPU and the peripheral clocks:

- CK_IDLE for alternate card and peripherals registers access
- CK_T0 for Timer 0
- CK_T1 for Timer 1
- CK_SI for the UART
- CK_WD for the Watchdog Timer
- CK_SPI for SPI

The CPU and peripherals clocks frequencies are defined in the table below.

CKS	X2	F _{CK_IDLE}
0	0	$F_{CK_XTAL1}/(2*(16-CKRL))$
0	1	F_{CK_XTAL1}
1	0	$F_{CK_PLL}/(2*(16-CKRL))$
1	1	Not allowed

X1 and X2 Modes

Use of on-chip oscillator

When the CPU and Peripherals clocks are fed by the on-chip oscillator, the CPU and Peripherals can be configured independently in X1 or X2 mode depending on the frequencies wanted by the user. There is however one exception : the peripherals can be configured in X2 mode while the CPU remains in X1 mode. This exception is handled by the hardware and the user does not need to take care of.

Table 1. X1 and X2 Mode Selection

CPU	Peripherals	Status	Frequenci
X1 mode	X1 mode	Allowed (default configuration at reset)	$F_{CK_IDLE} = F_{CK_PERIPH}$
X1 mode	X2 mode	Not Allowed by the hardware	
X2 mode	X1 mode	Allowed Once the CPU is switched to X2 mode, the user is free to switch any of the peripherals to X1 mode	$F_{CK_IDLE} = 2 * F_{CK_PERIPH}$
X2 mode	X2 mode	Allowed Default configuration when CPU is switched to X2 mode	$F_{CK_IDLE} = F_{CK_PERIPH}$

The X1 or X2 modes can be individually selected for the CPU and each peripheral by means of CKCON0 and CKCON1 registers. At reset, the CPU and Peripherals are set all by default to X1 mode. In this mode, changing any peripheral to X2 mode has no effect. When X2 bit is set in CKCON0 register, CPU and All peripherals are automatically switched to X2 mode. It is then possible for the user to individually switch any peripheral back to X1 mode.

In X1 mode (X2 bit cleared in CKCON0 regsiter), the PR1 prescaler is active while it is bypassed in X2 mode (X2 bit set in CKCON0 register).

The X1 mode is true only when the prescaler PR1 is set to 1/2 (default condition at reset).

Figure 20. X1 mode

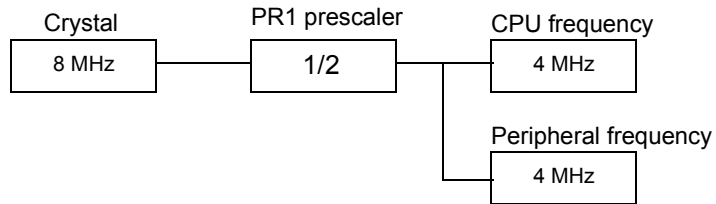

When the X1 mode is selected, the CPU and Peripherals work at 8MHz / X1

Figure 21. X2 mode

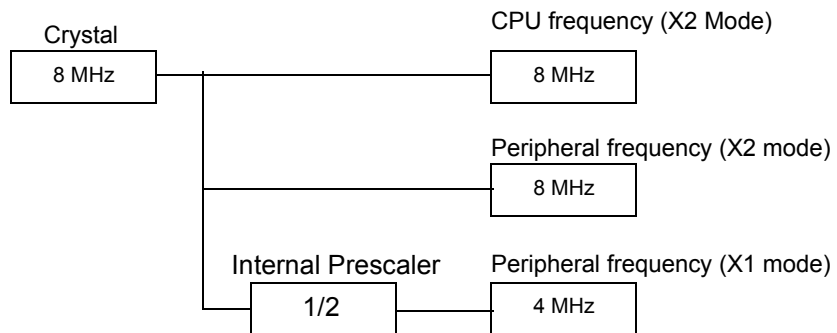

When the X2 mode is selected, the CPU works at 8 MHz / X2. The Peripherals can work at 8 MHz / X2 or 8 MHz / X1.

When the PR1 prescaler is different from 1/2, the usual X1 mode can not be defined. In this case, it is necessary to define a X1 or X2 equivalent mode from equivalent clock circuits.

Example : PR1=1/8, X2=0.

In this configuration, the CPU works at 1 MHz. This frequency could also be obtained by an equivalent clock circuit where the on-chip oscillator would run at 2 MHz in X1 mode or at 1 MHz in X2 mode. So we can say that the CPU works at 2 MHz / X1 or 1MHz / X2.

As the X2 bit is cleared in CKCON0 register, we have $F_{CK_IDLE} = F_{CK_PERIPH}$.

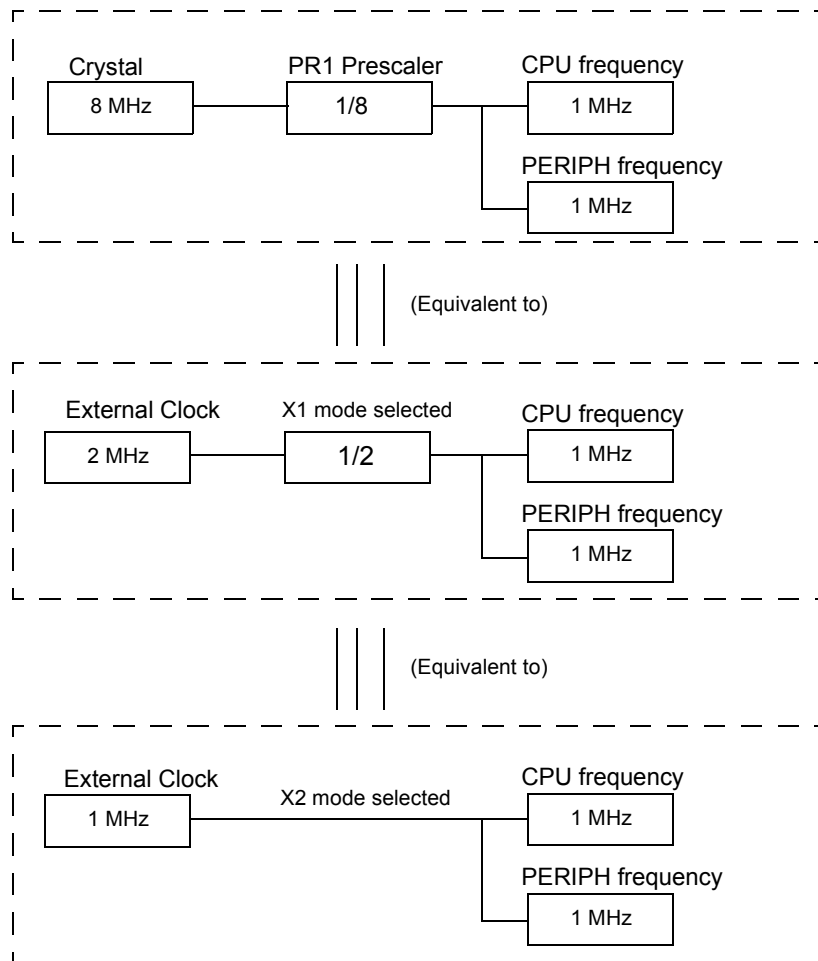

Use of PLL Clock

When the CPU clock is fed by the PLL, the X2 mode is forbidden. The bit X2 must always remain cleared in CKCON0 register. As the PR1 prescaler is always different from 1/2, the usual X1 mode can not be defined. So it is necessary to define an equivalent X1 or X2 mode from equivalent clock circuits, as in previous section.

Example: PR1=1/4, PLL feeds the CPU. The CPU works in this case at 24 MHz. This frequency could also be obtained by an equivalent clock circuit where the on-chip oscillator would run at 48 MHz in X1 mode or at 24 MHz in X2 mode. So we can say that in this configuration, the CPU works at 48 MHz / X1 or 24 MHz / X2 (See figures below).

As the X2 bit is cleared in CKCON0 register, we have always $F_{CK_IDLE} = F_{CK_PERIPH}$.

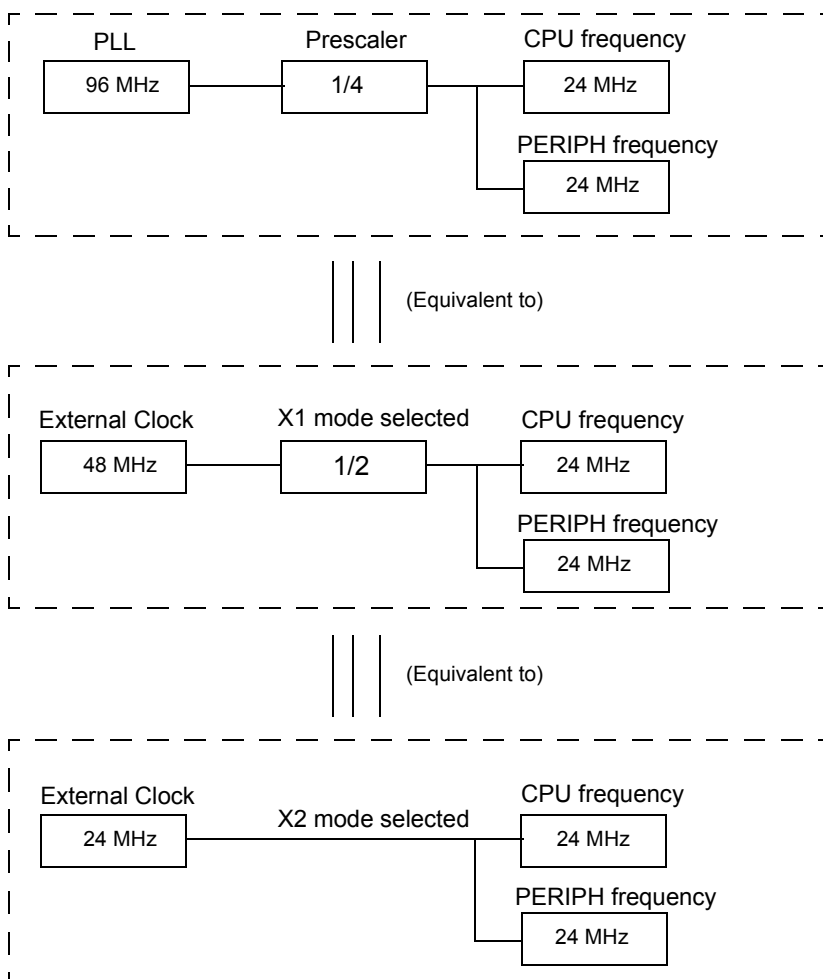

SCIB Clock

The Smart Card Interface Block (SCIB) uses two clocks :

- The first one, CK_IDLE, is the peripheral clock used for the interface with the microcontroller.
- The second one, CK_ISO, is independant from the CPU clock and is generated from the PLL or XTAL1 output.
PR2, a 6-bit prescaler, will be used to generate:
12/9.6/8/6.85/6/5.33/4.8/4.36/ .../1MHz frequencies.
SCIB clock frequency must be lower than CPU clock frequency.

During SCIB Reset, the CK_ISO input must be in the range 1 - 5 MHz according to ISO 7816. The SCIB clocks frequency is defined in Figure 41 on page 72 and Table 42 on page 72.

Two conditions must be met for a correct use of the SCIB:

- $CK_CPU > 4/3 * CK_ISO$ and
- $CK_CPU < 6 * CK_ISO$.

If the $CK_CPU \leq \frac{4}{3} * CK_ISO$, the SCIB doesn't work.

If the $CK_CPU \geq 6 * CK_ISO$, the programmer must take care of three cases:

- Read (or write) operation on a SCIB register followed immediately with another Read (or write) operation on the same register.
- Read (or write) operation on a SCIB register followed immediately with another Read (or write) operation on a linked register. The list of linked registers is in the table below.

Linked registers
Write in SCICR and after read of SCETU0-1
Write in SCIBUF and after read of SCISR

- Write operation on a register of the list below followed immediately with a read operation on a SCIB register.

Wait after Write operation on this registers
SCICR, SCIER, SCETU0-1, SCGT0-1, SCWT0-3, SCON

To avoid any trouble, a delay must be added between the two accesses on the SCIB register. The SCIB must complete the first read (or write) operation before to receive the second. A solution is to add NOP (no operation) instructions. The number of NOP to add depends of the rate between CK_CPU and CK_ISO (see table below).

Min CK_CPU	Max CK_CPU	Number of CPU cycles to add
$CK_CPU \geq 6 * CK_ISO$	$CK_CPU \leq 12 * CK_ISO$	6 (example1 NOP)
$CK_CPU \geq 12 * CK_ISO$	$CK_CPU \leq 16 * CK_ISO$	12 (example 2 NOP)

Alternate Card Clock

The alternate Card uses the peripheral clock divided by the PR3 prescaler. (1; 1/2; 1/4; 1/8 division ratio). See Section "Alternate Card", page 76 for the definition of the alternate clock.

DC/DC Converter Clock

The DC/DC block needs a clock with a 50% duty cycle. The frequency must also be included in the range 3.68 MHz and 6 MHz. The PR4 prescaler is used to configure the DC/DC frequency.

XTAL1 (MHz)	DCCKPS3:0 value	Prescaler Factor	DC/DC converter CLK (MHz)
8	0	2	4



USB Interface Clock

The USB Interface uses two clocks :

- The first one is the CPU clock used for the interface with the microcontroller, CK_IDLE.
- The second one is the CK_USB supplied from the PLL through a divider by 2.

Registers

Table 24. Clock Selection Register - CKSEL (S:85h)

7	6	5	4	3	2	1	0
-	-	-	-	-	-	-	CKS

Bit Number	Bit Mnemonic	Description
7:1	-	Reserved The value read from this bit is indeterminate. Do not set this bit.
0	CKS	CPU Oscillator Select Bit Set this bit to connect CPU and Peripherals to PLL output. Clear this to to connect CPU and Peripherals to XTAL1 clock input.

Reset Value = XXXX XXX0b

Table 25. Clock Reload Register - CKRL (S:97h)

7	6	5	4	3	2	1	0
-	-	-	-	CKRL3	CKRL2	CKRL1	CKRL0

Bit Number	Bit Mnemonic	Description
7 - 4	-	Reserved The value read from this bit is indeterminate. Do not set this bit.
3:0	CKRL3:0	Clock Reload register Prescaler1 value $F_{ck_cpu} = [1 / 2^{(16-CKRL)}] * F_{ck_XTAL1}$

Reset Value = XXXX 1111b

Table 26. Clock Configuration Register 0 - CKCON0 (S:8Fh)

7	6	5	4	3	2	1	0
-	WDX2	-	SIX2	-	T1X2	T0X2	X2
Bit Number	Bit Mnemonic	Description					
7	-	Reserved The value read from this bit is indeterminate. Do not set this bit.					
6	WDX2	Watchdog clock This control bit is validated when the CPU clock X2 is set; when X2 is low, this bit has no effect. Cleared to bypass the 1/2 prescaler. Set to select the 1/2 output for this peripheral.					
5	-	Reserved The value read from this bit is indeterminate. Do not set this bit.					
4	SIX2	Enhanced UART clock (Mode 0 and 2) This control bit is validated when the CPU clock X2 is set; when X2 is low, this bit has no effect. Cleared to bypass the 1/2 prescaler. Set to select the 1/2 output for this peripheral.					
3	-	Reserved The value read from this bit is indeterminate. Do not set this bit.					
2	T1X2	Timer 1 clock This control bit is validated when the CPU clock X2 is set; when X2 is low, this bit has no effect. Cleared to bypass the 1/2 prescaler. Set to select the 1/2 output for this peripheral.					
1	T0X2	Timer 0 clock This control bit is validated when the CPU clock X2 is set; when X2 is low, this bit has no effect. Cleared to bypass the 1/2 prescaler. Set to select the 1/2 output for this peripheral.					
0	X2	System clock Control bit Cleared to select the PRT output for CPU and all the peripherals . Set to bypass the PRT prescaler and to enable the individual peripherals 'X2' bits.					

Reset Value = X0X0 X000b

Table 27. Clock Configuration Register 1 - CKCON1 (S:AFh) only for AT8xC5122

7	6	5	4	3	2	1	0
-	-	-	-	-	-	-	SPIX2
Bit Number	Bit Mnemonic	Description					
7 - 4	-	Reserved The value read from this bit is indeterminate. Do not set this bit.					
3	-	Reserved The value read from this bit is indeterminate. Do not set this bit.					
0	SPIX2	SPI clock This control bit is validated when the CPU clock X2 is set. When X2 is low, this bit has no effect. Cleared to bypass the 1/2 prescaler. Set to select the 1/2 output for this peripheral.					

Reset Value = XXXX XXX0b

Table 28. PLL Control Register - PLLCON (S:A3h)

7	6	5	4	3	2	1	0
-	-	-	-	-	EXT48	PLLEN	PLOCK
Bit Number	Bit Mnemonic	Description					
7 - 3	-	Reserved The value read from these bits is always 0. Do not set this bits.					
2	EXT48	External 48 MHz Enable Bit Set this bit to select XTAL1 as USB clock. Clear this bit to select PLL as USB clock. SCIB clock is controlled by EXT48 bit and XTSCS bit.					
1	PLLEN	PLL Enable bit Set to enable the PLL. Clear to disable the PLL.					
0	PLOCK	PLL Lock Indicator Set by hardware when PLL is locked Clear by hardware when PLL is unlocked					

Reset Value = 0000 0000b

Table 29. PLL Divider Register - PLLDIV (S:A4h)

7	6	5	4	3	2	1	0
R3	R2	R1	R0	N3	N2	N1	N0
Bit Number	Bit Mnemonic	Description					
7 - 4	R3:0	PLL R Divider Bits					
3 - 0	N3:0	PLL N Divider Bits					

Reset Value = 0000 0000b

I/O Port Definition

Ports vs Packages

Table 30. I/O Number vs Packages

	P0	P1	P2	P3	P4	P5	Total
VQFP64 QFN64	8	8	8	8	6	8	46
VQFP32 QFN32	-	8	-	8	-	1	17
PLCC28	-	6	-	6	-	1	13

Port 0

Port 0 has the following functions:

- Default function: Port 0 is an 8-bit I/O port.
- Alternate function: Port 0 is also the multiplexed low-order address and data bus during accesses to external Program and Data Memory. In this application, it uses strong internal pull-ups when emitting 1's and it can drive CMOS inputs without external pull-ups.

Port 0 has the following configurations:

- Default configuration: open drain bi-directional I/O port. Port 0 pins that have 1's written to them float, and in this state they can be used as high-impedance inputs.
- Configuration 2: Low speed output, "KB_OUT"
- Configuration 3: Push-pull output

Port 1

Port 1 has the following functions:

- Default function : Only Port 1.2, P1.6 and P1.7 are standard I/O's; the other ports can be activated only with the SCIB function.
- Alternate function and configuration: see Table 31.

Table 31. Port 1 Description.

Port	Alternate Function		Configuration	
	Signal	Description	Mode	Comments
	CIO	Smart card interface function Card I/O	Quasi-bidirectional port supplied by DC/DC converter	Low level at reset. Caution : if DPU bit is set in AUXR register, the weak-pull of the port is disabled
	CC8	Smart card interface function Card contact 8	Quasi-bidirectional port supplied by DC/DC converter	Low level at reset Caution : if DPU bit is set in AUXR register, the weak-pull of the port is disabled
P1.2	CPRES	Smart card interface function Card presence	Quasi-bidirectional port supplied by VCC	Weak & medium pull-up's can be disconnected by CPRESRES bit in PMOD0 register High Level at reset
	CC4	Smart card interface function Card contact 4	Quasi-bidirectional port supplied by DC/DC converter	Low level at reset Caution : if DPU bit is set in AUXR register, the weak-pull of the port is disabled
	CCLK	Smart card interface function Card clock	Push-Pull port supplied by DC/DC converter	Low level at reset
	CRST	Smart card interface function Card reset	Push-Pull port supplied by DC/DC converter	Low level at reset
P1.6	\overline{SS}	\overline{SS} pin of the SPI function	Quasi-bidirectional supplied by VCC	
P1.7	CCLK1	Alternate Card Clock output	Quasi-bidirectional supplied by VCC	Alternate Card Clock function disabled
			Quasi-bidirectional supplied by VCC	Alternate Smart Card Clock enabled Switched automatically to Push-pull (see Table 47 on page 80)

Port 2

Port 2 has the following functions:

- Default function: Port 2 is an 8-bit I/O port.
- Alternate function 1: Port 2 is also the multiplexed high-order address during accesses to external Program and Data Memory. In this application, it uses strong internal pull-ups when emitting 1's and it can drive CMOS inputs without external pull-ups.

Port 2 has the following configurations:

- Default configuration: Pseudo bi-directional "Port51" digital input/output with internal pull-ups.
- Configuration 1: Push-pull output
- Configuration 2: Low speed output, "KB_OUT"
- Configuration 3: Input with weak pull-up, "WPU input"

Port 3

Port 3 has the following functions:

- Default function: Port 3 is an 8-bit I/O port.
- Alternate functions: see table below

Port 3 has the following configurations:

- Default configuration: Pseudo bi-directional “Port51” digital input/output with internal pull-ups.
- Alternate configurations: See Table 32.

Table 32. Port 3 Description

Port	Alternate Functions		Configurations			
	Signal	Description	Mode 1	Mode 2	Mode 3	Mode 4
P3.0	RxD	Receiver data input (asynchronous) or data input/output (synchronous) of the serial interface	Push-pull	KB_OUT	Input WPU	
P3.1	TxD	Transmitter data output (asynchronous) or clock output (synchronous) of the serial interface	Push-pull	KB_OUT	Input WPU	
P3.2	INT0	External interrupt 0 input/timer 0 gate control input				LED0
P3.3	INT1	External interrupt 1 input/timer 1 gate control input	Push-pull	KB_OUT	Input WPU	
P3.4	T0	Timer 0 counter input	Push-pull	KB_OUT	Input WPU	LED1
P3.5	T1	Timer 1 counter input				
P3.6	WR	External Data Memory write strobe; latches the data byte from port 0 into the external data memory				LED2
P3.7	RD	External Data Memory read strobe; Enables the external data memory. Port 3 can drive CMOS inputs without external pull-ups				LED3



Port 4

Port 4 has the following functions:

- Default function: Port 4 is an 6-bit I/O port.
- Alternate functions: see table below

Port 4 has the following configurations:

- Default configuration: Pseudo bi-directional “Port51” digital input/output with internal pull-ups.
- Alternate configurations: See Table 33.

Table 33. Port 4 Description

Port	Alternate Functions		Configurations		
	Signal	Description	Mode 1	Mode 2	Mode 3
P4.0	MISO	SPI Master In Slave Out I/O			
P4.1	MOSI	SPI Master Out Slave In I/O			
P4.2	SCK	SPI clock			
P4.3			Push-pull	KB_OUT	Input MPU
P4.4			Push-pull	KB_OUT	Input MPU
P4.5			Push-pull	KB_OUT	Input MPU

Port 5

Port 5 has the following functions:

- Default function: Port 5 is an 8-bit I/O port.
- Alternate function 1: Port 5 is an 8-bit keyboard port KB0 to KB7.

Port 5 has the following configurations:

- Default configuration: Pseudo bi-directional “Port51” digital input/output with internal pull-ups.
- Alternate configuration: see Table 34.

Table 34. Port 5 Description

Port	Configurations			Comments
	Mode 1	Mode 2	Mode 3	
P5.0	Push-pull	Input MPU	Input WPU	First cluster
P5.1	Push-pull	Input MPU	Input WPU	
P5.2	Push-pull	Input MPU	Input WPU	
P5.3	Push-pull	Input WPD	Input WPU	Second cluster
P5.4	Push-pull	Input WPD	Input WPU	
P5.5	Push-pull	Input WPD	Input WPU	
P5.6	Push-pull	Input WPD	Input WPU	Third cluster
P5.7	Push-pull	Input WPD	Input WPU	

Port Configuration

Standard I/O P0

The P0 port is described in Figure 22.

Figure 22. Standard Input/Output Port

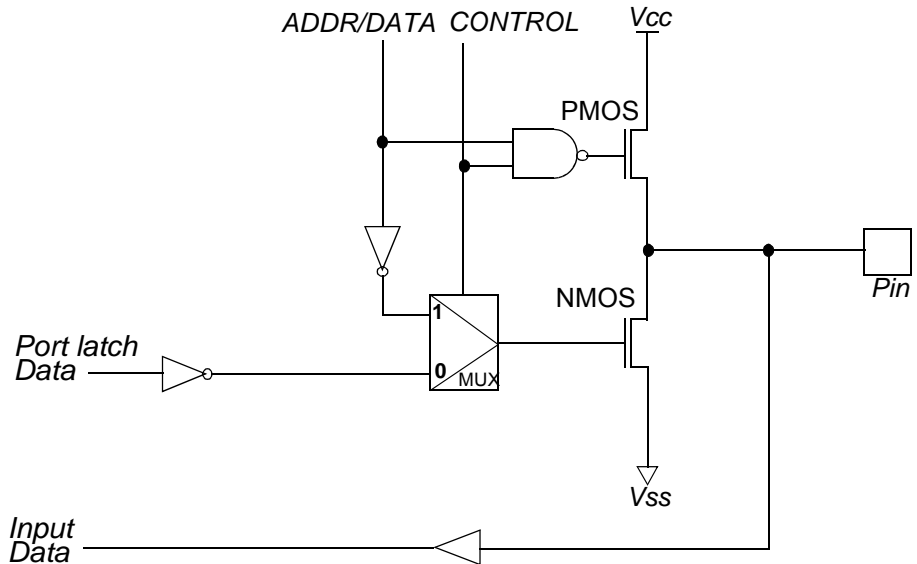

Quasi Bi-directional Port

The default port output configuration for standard I/O ports is the quasi-bi-directional output that is common on the 80C51 and most of its derivatives. The “Port51” output type can be used as both an input and output without the need to reconfigure the port. This is possible because when the port outputs a logic high, it is weakly driven, allowing an external device to pull the pin low.

When the port outputs a logic low state, it is driven strongly and is able to sink a fairly large current.

These features are somewhat similar to an open-drain output except that there are three pull-up transistors in the quasi-bi-directional output that serve different purposes.

One of these pull-ups, called the weak pull-up, is turned on whenever the port latch for the pin contains a logic 1. The weak pull-up sources a very small current that will pull the pin high if it is left floating. The weak pull-up can be turned off by the DPU bit in AUXR register.

A second pull-up, called the medium pull-up, is turned on when the port latch for the pin contains a logic 1 and the pin itself is also at a logic 1 level. This pull-up provides the primary source current for a quasi-bi-directional pin that is outputting a 1. If a pin that has a logic 1 on it is pulled low by an external device, the medium pull-up turns off, and only the weak pull-up remains on. In order to pull the pin low under these conditions, the external device has to sink enough current to overpower the medium pull-up and take the voltage on the port pin below its input threshold.

Note: for CIO, CC4, CC8 ports of SCIB interface, in input mode when the ICC (smart card) is driving the port pin:

- if $0 < V_{in} < CVCC/2$: weak pull-up is active (~100KOhm)
- if $CVCC/2 < V_{in} < CVCC$: weak (~100KOhm) and medium (~12KOhm) pull-up's are active

The "Port51" is described in Figure 23.

Figure 23. Quasi Bi-directional Port

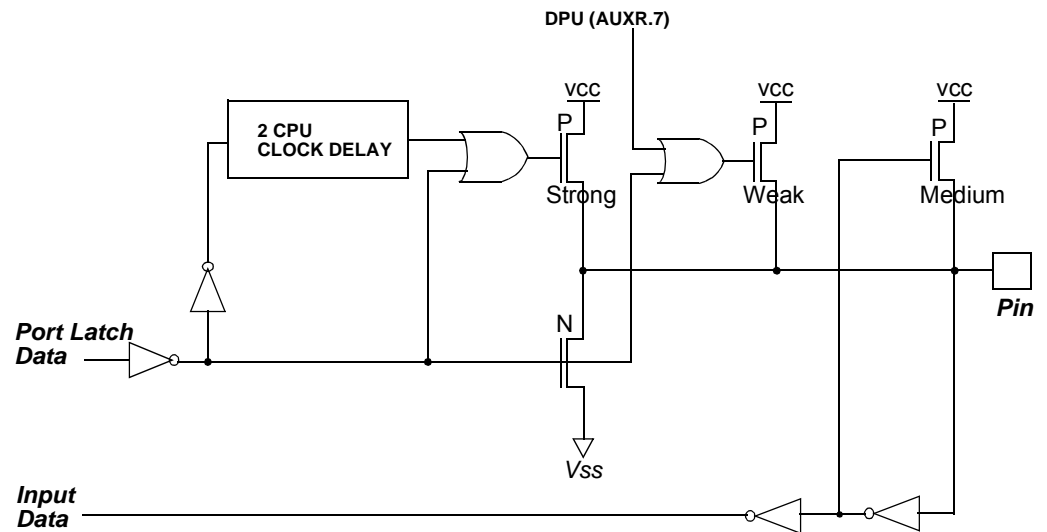

Push-pull Output Configuration

The push-pull output configuration has the same pull-down structure as both the open drain and the quasi-bi-directional output modes, but provides a continuous strong pull-up when the port latch contains a logic 1. The push-pull mode may be used when more source current is needed from a port output.

The Push-pull port configuration is shown in Figure 24.

Figure 24. Push-pull Output

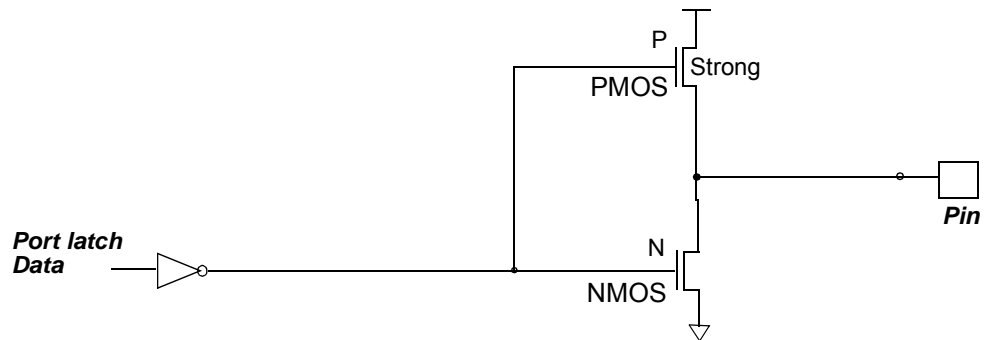

Input with Medium or Weak Pull-up Configuration

The input with pull-up (Input MPU and Input WPU) configuration is shown in Figure 25.

Figure 25. Input with Pull-up

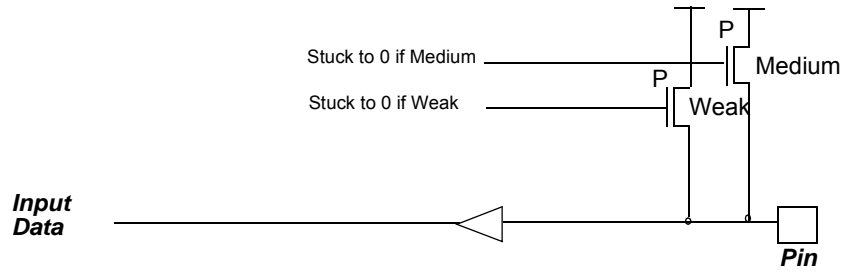

Input with Weak Pull-down Configuration

The input with pull-down (input WPD) configuration is shown in Figure 26

Figure 26. Input with Pull-down

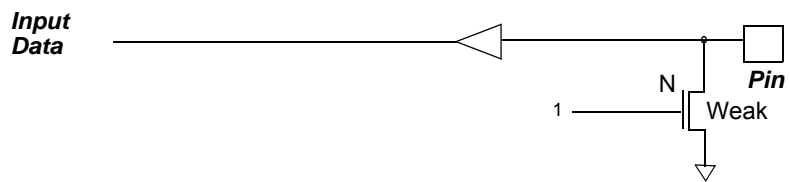

Low Speed Output Configuration

The low speed output with low speed t_{FALL} and t_{RISE} can drive keyboard.

The current limitation of the LED2CTRL block requires a polarisation current of about 250 μA . This block is automatically disabled in power-down mode.

The low speed output configuration (KB_OUT) is shown in Figure 27.

Figure 27. Low-speed Output

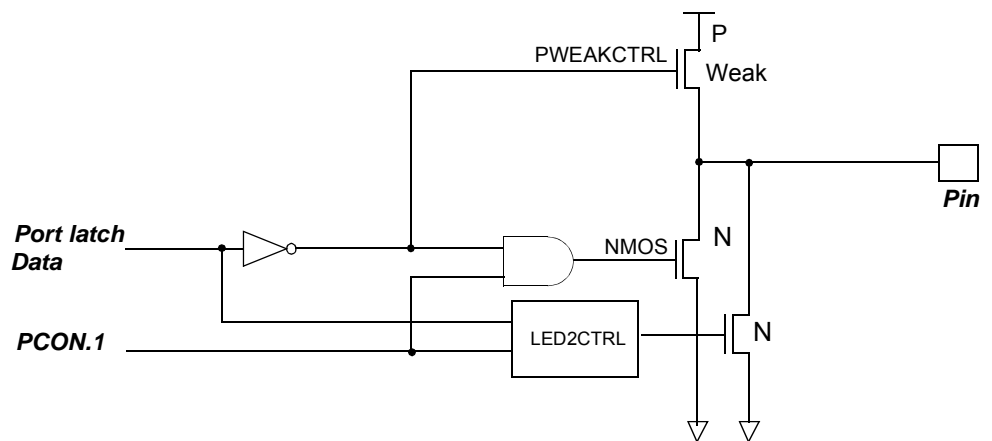

LED Source Current

The LED configuration is shown in Figure 28.

Figure 28. LED Source Current

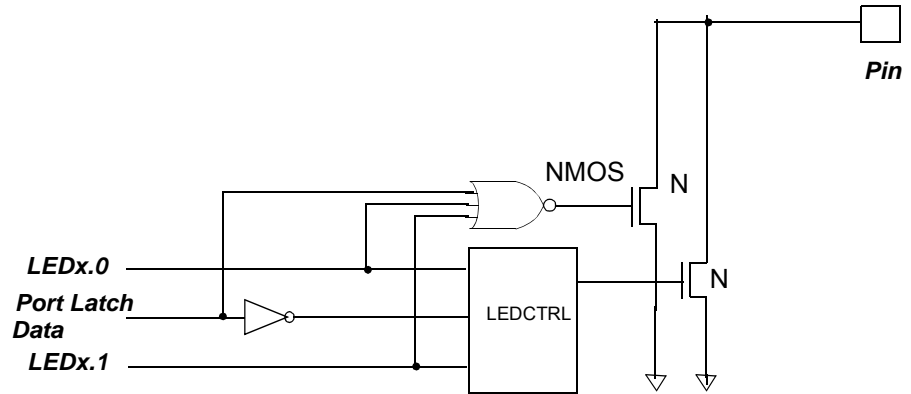

- Notes:
1. When switching a low level, LEDCTRL device has a permanent current of about $N \text{ mA}/15$ (N is 2, 4 or 8).
 2. The port must be configured as standard C51 port by means of PMOD0 and PMOD1 registers and the level of current must be programmed by means of LEDCON0 and LEDCON1 registers before switching the led on.

Table 35. LED Source Current

LEDx.1	LEDx.0	Port Latch Data	NMOS	PIN	Comments
0	0	0	1	0	LED control disabled
0	0	1	0	1	
0	1	0	0	0	LED mode 2 mA
0	1	1	0	1	
1	0	0	0	0	LED mode 4 mA
1	0	1	0	1	
1	1	0	0	0	LED mode 10 mA
1	1	1	0	1	

Registers

Table 36. Port Mode Register 0 - PMOD0 (91h) for AT8xC5122

7	6	5	4	3	2	1	0
P3C1	P3C0	P2C1	P2C0	CPRESRES	-	P0C1	P0C0
Bit Number	Bit Mnemonic	Description					
7 - 6	P3C1-P3C0	Port 3 Configuration bits (Applicable to P3.0, P3.1, P3.3, P3.4 only) 00 Quasi bi-directional 01 Push-pull 10 Output Low Speed 11 Input with weak pull-up					
5-4	P2C1-P2C0	Port 2 Configuration bits 00 Quasi bi-directional 01 Push-pull 10 Output Low Speed 11 Input with weak pull-down					
3	CPRESRES	Card Presence Pull-up resistor Cleared to connect the internal 100K pull-up Set to disconnect the internal pull-up					
2	-	Reserved The value read from this bit is indeterminate. Do not set this bit.					
1-0	P0C1-P0C0	Port 0 Configuration bits 00 C51 Standard P0 01 Reserved 10 Output Low Speed 11 Push-pull					

Reset Value = 0000 0x00b

Table 37. Port Mode Register 0 - PMOD0 (91h) for AT83C5123

7	6	5	4	3	2	1	0
P3C1	P3C0	-	-	CPRESRES	-	-	-
Bit Number	Bit Mnemonic	Description					
7 - 6	P3C1-P3C0	Port 3 Configuration bits (Applicable to P3.0, P3.1, P3.3, P3.4 only) 00 Quasi bi-directional 01 Push-pull 10 Output Low Speed 11 Input with weak pull-up					
5-4		Reserved The value read from these bits are indeterminate. Do not set these bit.					
3	CPRESRES	Card Presence Pull-up resistor Cleared to connect the internal 100K pull-up Set to disconnect the internal pull-up					
2-0	-	Reserved The value read from these bits are indeterminate. Do not set these bit.					

Reset Value = 00xx 0xxx b



Table 38. Port Mode Register 1 - PMOD1 (84h) for AT8xC5122

7	6	5	4	3	2	1	0
P5HC1	P5HC0	P5MC1	P5MC0	P5LC1	P5LC0	P4C1	P4C0
Bit Number	Bit Mnemonic	Description					
7 - 6	P5HC1-P5HC0	Port 5 High Configuration bits (Applicable from P5.6 to P5.7 only) 00 Quasi bi-directional 01 Push-pull 10 Input with weak pull-down 11 Input with weak pull-up					
5 - 4	P5MC1-P5MC0	Port 5 Medium Configuration bits (Applicable from P5.3 to P5.5 only) 00 Quasi bi-directional 01 Push-pull 10 Input with weak pull-down 11 Input with weak pull-up					
3 - 2	P5LC1-P5LC0	Port 5 Low Configuration bits (Applicable from P5.0 to P5.2 only) 00 Quasi bi-directional 01 Push-pull 10 Input with medium pull-up 11 Input with weak pull-up					
1 - 0	P4C1-P4C0	Port 4 Configuration bits (Applicable from P4.3 to P4.5 only) 00 Quasi bi-directional 01 Push-pull 10 Output Low Speed 11 Input with medium pull-up					

Reset Value = 0000 0000b

Table 39. Port Mode Register 1 - PMOD1 (84h) for AT83C5123

7	6	5	4	3	2	1	0
-	-	-	-	P5LC1	P5LC0	-	-
Bit Number	Bit Mnemonic	Description					
7 - 4		Reserved The value read from this bit is indeterminate. Do not set this bit.					
3 - 2	P5LC1-P5LC0	Port 5 Low Configuration bits (Applicable from P5.0 to P5.2 only) 00 Quasi bi-directional 01 Push-pull 10 Input with medium pull-up 11 Input with weak pull-up					
1 - 0		Reserved The value read from this bit is indeterminate. Do not set this bit.					

Reset Value = xxxx 00xxb

Table 40. LED Port Control Register 0 - LEDCON0 (F1h)

	7	6	5	4	3	2	1	0
	LED3.1	LED3.0	LED2.1	LED2.0	LED1.1	LED1.0	LED0.1	LED0.0

Bit Number	Bit Mnemonic	Description
7 - 6	LED3	Port LED3 Configuration bits 00 LED control disabled 01 2 mA current source when P3.7 is configured as Quasi-bi-directional mode 10 4 mA current source when P3.7 is configured as Quasi-bi-directional mode 11 10 mA current source when P3.7 is configured as Quasi-bidirect. mode
5 - 4	LED2	Port LED2 Configuration bits 00 LED control disabled 01 2 mA current source when P3.6 is configured as Quasi-bi-directional mode 10 4 mA current source when P3.6 is configured as Quasi-bi-directional mode 11 10 mA current source when P3.6 is configured as Quasi-bidirect. mode
3 - 2	LED1	Port LED1 Configuration bits 00 LED control disabled 01 2 mA current source when P3.4 is configured as Quasi-bi-directional mode 10 4 mA current source when P3.4 is configured as Quasi-bi-directional mode 11 10 mA current source when P3.4 is configured as Quasi-bidirect. mode
1 - 0	LED0	Port LED0 Configuration bits 00 LED control disabled 01 2 mA current source when P3.2 is configured as Quasi-bi-directional mode 10 4 mA current source when P3.2 is configured as Quasi-bi-directional mode 11 10 mA current source when P3.2 is configured as Quasi-bidirect. mode

Reset Value = 0000 0000b

Table 41. LED Port Control Register 1- LEDCON1 (F1h) only for AT8xC5122

	7	6	5	4	3	2	1	0
	-	-	LED6.1	LED6.0	LED5.1	LED5.0	LED4.1	LED4.0

Bit Number	Bit Mnemonic	Description
7 - 6		Reserved The value read from this bit is indeterminate. Do not set this bit.
5 - 4	LED6	Port LED6 Configuration bits 00 LED control disabled 01 2 mA current source when P4.5 is configured as Quasi-bi-directional mode 10 4 mA current source when P4.5 is configured as Quasi-bi-directional mode 11 10 mA current source when P4.5 is configured as Quasi-bidirect. mode
3 - 2	LED5	Port LED5 Configuration bits 00 LED control disabled 01 2 mA current source when P4.4 is configured as Quasi-bi-directional mode 10 4 mA current source when P4.4 is configured as Quasi-bi-directional mode 11 10 mA current source when P4.4 is configured as Quasi-bidirect. mode
1 - 0	LED4	Port LED0 Configuration bits 00 LED control disabled 01 2 mA current source when P4.3 is configured as Quasi-bi-directional mode 10 4 mA current source when P4.3 is configured as Quasi-bi-directional mode 11 10 mA current source when P4.3 is configured as Quasi-bidirect. mode

Reset Value = 0000 0000b



Smart Card Interface Block (SCIB)

The SCIB provides all signals to interface directly with a smart card. The compliance with the ISO7816, EMV'2000, GSM and WHQL standards has been certified.

Both synchronous (e.g. memory card) and asynchronous smart cards (e.g. microprocessor card) are supported. The component supplies the different voltages requested by the smart card. The power off sequence is directly managed by the SCIB.

The card presence switch of the smart card connector is used to detect card insertion or card removal. In case of card removal, the SCIB de-activates the smart card using the de-activation sequence. An interrupt can be generated when a card is inserted or removed.

Any malfunction is reported to the microcontroller (interrupt + control register).

The different operating modes are configured by internal registers.

- Support of ISO/IEC 7816
- character mode
- one transmit/receive buffer
- 11 bits ETU counter
- 9 bits guard time counter
- 32 bits waiting time counter
- Auto character repetition on error signal detection in transmit mode
- Auto error signal generation on parity error detection in receive mode
- Power on and power off sequence generation
- Manual mode to drive directly the card I/O

Block Diagram

The Smart Card Interface Block diagram is shown Figure 29:

Figure 29. SCIB Block Diagram

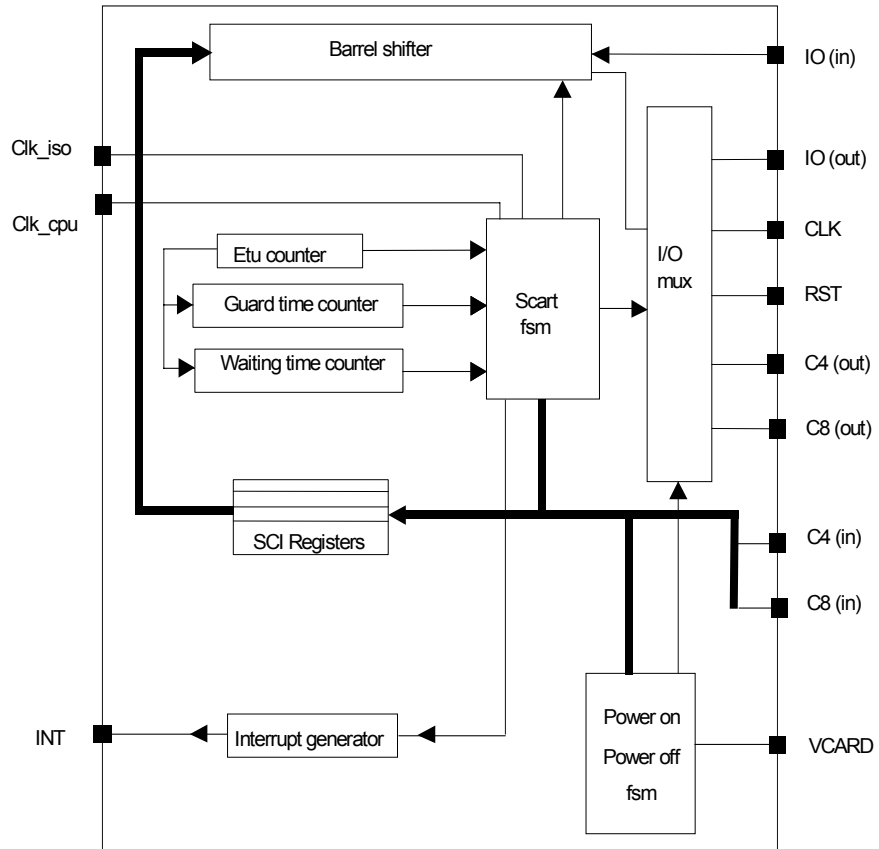

Definitions

This paragraph introduces some of the terms used in ISO 7816-3 and EMV recommendations. Please refer to the full recommendations for a complete list of terms.

Terminal and ICC

Terminal is the reader, ICC is the Integrated Circuit Card

ETU

Elementary Timing Unit (Bit time)

T=0

Character oriented half duplex protocol T=0

T=1

Block oriented half duplex protocol T=1

Activation: Cold Reset

Reset initiated by the Terminal with Vcc power-up. The card will answer with ATR (see below)

Activation: Warm Reset

Reset initiated by the Terminal with Vcc already powered-up, and after a prior ATR or Warm Reset

De-Activation

Deactivation by the Terminal as a result of : unresponsive ICC, or ICC removal.



ATR	Answer To Reset. Response from the ICC to a Reset initiated by the Terminal
F and D	$F = \text{Clock Rate Conversion Factor}$, $D = \text{Bit rate adjustment factor}$. ETU is defined as : $ETU = F/(D*f)$ with $f = \text{Card Clock frequency}$. If f is in Hertz, ETU is in second. F and D are available in the ATR (byte TA1). The default values are $F=372$, $D=1$.
Guard Time	The time between 2 leading edges of the start bit of 2 consecutive characters is comprised of the character duration (10) plus the guard time. Be aware that the Guard Time counter and the Guard Time registers in the AT8xC5122/23 consider the time between 2 consecutive characters. So the equation is $\text{Guard Time Counter} = \text{Guard Time} + 10$. In other words, the Guard Time is the number of Stop Bits between 2 characters sent in the same direction.
Extra Guard Time	ISO IEC 7816-3 and EMV introduce the Extra Guard time to be added to the minimum Guard Time. Extra Guard Time only apply to consecutive characters sent by the terminal to the ICC. The TC1 byte in the ATR define the number N . For $N=0$ the character to character duration is 12 ETUs. For $N=254$ the character to character duration is 266. For $N=255$ (special case) The minimum character to character duration is to be used : 12 for T=0 protocol and 11 for T=1 protocol.
Block Guard Time	The time between the leading edges of 2 consecutive characters sent in opposit direction. ISO IEC 7816-3 and EMV recommend a fixed Block Guard Time of 22 ETUs.
Work Waiting Time (WWT)	In T=0 protocol WWT is the interval between the leading edge of any character sent by the ICC, and the leading edge of the previous character sent either by the ICC or the Terminal. If no character is received by the terminal after WWTmax time, the Terminal initiates a De-Activation Sequence.
Character Waiting Time (CWT)	In T=1 protocol CWT is the interval between the leading edge of 2 consecutive characters sent by the ICC. If the next character is not received by the Terminal after CWTmax time, the Terminal initiates a De-Activation Sequence.
Block Waiting Time (BWT)	In T=1 protocol BWT is the interval between the leading edge of the start bit of the last character sent by the Terminal that gives the right to sent to the ICC, and the leading edge of the start bit of the first character sent by the ICC. If the first character from the ICC is not received by the Terminal after BWTmax time, the Terminal initiates a De-Activation Sequence.
Waiting Time Extention (WTX)	In T=1 protocol the ICC can request a Waiting Time Extension with a S(WTX request) request. The Terminal should acknowledge it. The Waiting time between the leading edge of the start bit of the last character sent by the Terminal that gives the right to sent to the ICC, and the leading edge of the start bit of the first character sent by the ICC will be $BWT*WTX$ ETUs.
Parity error in T=0 protocol	In T=0 protocol, a Terminal (respectively an ICC) detecting a parity error while receiving a character shall force the Card IO line at 0 starting at 10.5 ETUs, thus reducing the first Guard bit by half the time. The Terminal (respectively an ICC) shall maintain a 0 for 1 ETU min and 2 ETUs max (according to ISO IEC) or to 2 ETUs (according to EMV). The ICC (respectively a Terminal) shall monitor the Card IO to detect this error signal then attempt to repeat the character. According to EMV, following a parity error the character can be repeated one time, if parity error is detected again this procedure can be repeated 3 more times. The same character can be transmitted 5 times in total. ISO

IEC7816-3 says this procedure is mandatory in ATR for card supporting T=0 while EMV says this procedure is mandatory for T=0 but does not apply for ATR.

Functional Description

The architecture of the Smart Card Interface Block can be detailed as follows:

Barrel Shifter

The Barrel Shifter performs the translation between 1 bit serial data and 8 bits parallel data

The barrel function is useful for character repetition since the character is still present in the shifter at the end of the character transmission.

This shifter is able to shift the data in both directions and to invert the input or output value in order to manage both direct and inverse ISO7816-3 convention.

Coupled with the barrel shifter is a parity checker and generator.

There are 2 registers connected to this barrel shifter, one for the transmission and one for the reception. They act as buffers to relieve the CPU of timing constraints.

SCART FSM

(Smart Card Asynchronous Receiver Transmitter Finite State Machine)

This is the core of the block. Its purpose is to control the barrel shifter. To sequence correctly the barrel shifter for a reception or a transmission, it uses the signals issued by the different counters. One of the most important counters is the guard time counter that gives time slots corresponding to the character frame.

The SCART FSM is enabled only in UART mode.

The transition from the receipt mode to the transmit mode is done automatically. Priority is given to the transmission. Transmission refers to Terminal transmission to the ICC. Reception refers to reception by the Terminal from the ICC.

ETU Counter

The ETU (Elementary Timing Unit) counter controls the working frequency of the barrel shifter, in fact it generates the enable signal of the barrel shifter. It receives the Card Clock, and generates the ETU clock. The Card Clock frequency is called "f" below. The ETU counter is 11 bit wide.

A special compensation mode can be activated. It accommodates situations where the ETU is not an integer number of Card Clock (CK_ISO). The compensation mode is controlled by the COMP bit in SCETU1 register bit position 7. With COMP=1 the ETU of every character even bits is reduced by 1 Card Clock period. As a result, the average ETU is : $ETU_{average} = (ETU - 0.5)$. One should bear in mind that the ETU counter should be programmed to deliver a faster ETU which will be reduced by the COMP mechanism, not the other way around. This allows to reach the required precision of the character duration specified by the ISO7816-3 standard.

Example1 : $F=372, D=32 \Rightarrow ETU = F/D = 11.625$ clock cycles.

We select $ETU[10-0] = 12$, COMP=1. $ETU_{average} = 12 - (0.5 * COMP) = 11.5$

The result will be a full character duration (10 bit) = $(10 - 0.107) * ETU$. The EMV specification is $(10 +/- 0.2) * ETU$

Guard Time Counter

The minimum time between the leading edge of the start bit of 2 consecutive characters transmitted by the Terminal is controlled by the Guard Time counter, as described in Figure 32.

The Guard Time counter is an 9 bit counter It is initialized at 001h at the start of a transmission by the Terminal. It then increments itself at each ETU until it reach the 9 bit value loaded into the SCGT1[0] concatenated with SCGT0[7:0]. At this time a new Terminal transmission is enabled and the Guard Time Counter stop incrementing. As soon as a new transmission start, the Guard Time Counter is re-initialized at 1 decimal value.

It should be noted that the value of the Guard Time Counter cannot be red. Reading SCGT1,0 only gives the minimum time between 2 characters that the Guard Time Counter will allow.

Care must be taken with the Guard Time Counter which counts the duration between the leading edges of 2 consecutive characters. This correspond to the character duration (10 ETU) plus the Guard Time as defined by the ISO and EMV recommendations. To program Guard Time = 2 : 2 stop bits between 2 characters which is equivalent to the minimum delay of 12 ETUs between the leading edges of 2 consecutive characters, SCGT1[0],SCGT0[7:0] should be loaded with the value 12 decimal. See Figure 30

Figure 30. Guard Time.

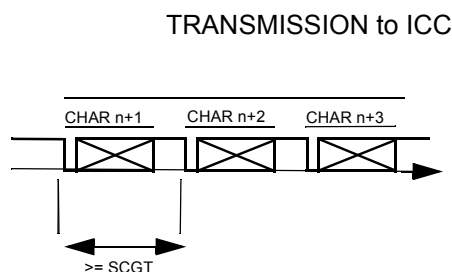

Block Guard Time Counter

The Block Guard Time counter provides a way to program a minimum time between the leading edge of the start bit of a character received from the ICC and the leading edge of the start bit of a character sent by the terminal. ISO IEC 7816-3 and EMV recommend a fixed Block Guard Time of 22 ETUs. The AT8xC5122/23 offer the possibility to extend this delay up to 512 ETUs.

The Block Guard Time is a 9 bit counter. When the Block Guard Time mode is enabled (BGTEN=1 in SCSR register) The Block Guard Time counter is initialized at 000h at the start of each character transmissions from the ICC. It then increments at each ETU until it reach the 9 bit value loaded into shadow SCGT1,0 registers, or until it is re-initialized by the start of an new transmission from the ICC. If the Block Guard Time counter reaches the 9 bit value loaded into shadow SCGT1,0 registers, a transmission by the TERMINAL is enabled, and the Block Guard Time counter stop incrementing. The Block Guard Time counter is re-initialized at the start of each TERMINAL transmission.

The SCGT1 SCGT0 shadow registers are loaded with the content of GT[8-0] contained in the registers SCGT1[0],SCGT0(7:0] with the rising edge of the bit BGTEN in the SCSR register. See Figure 32.

Figure 31. Block Guard Time.

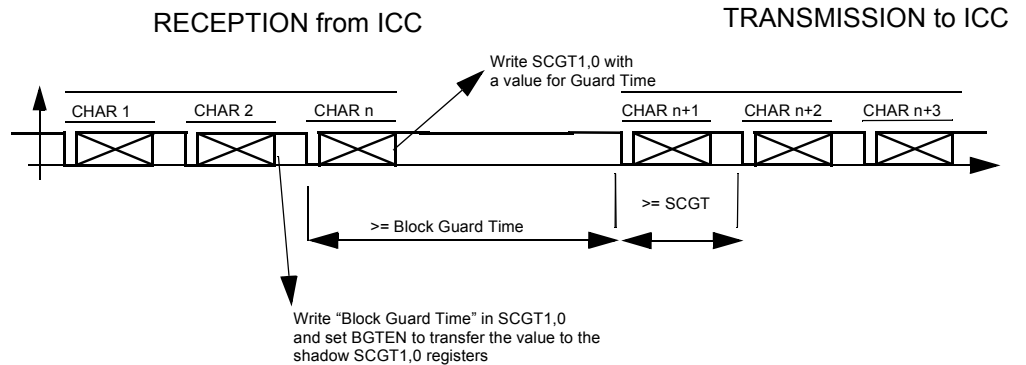
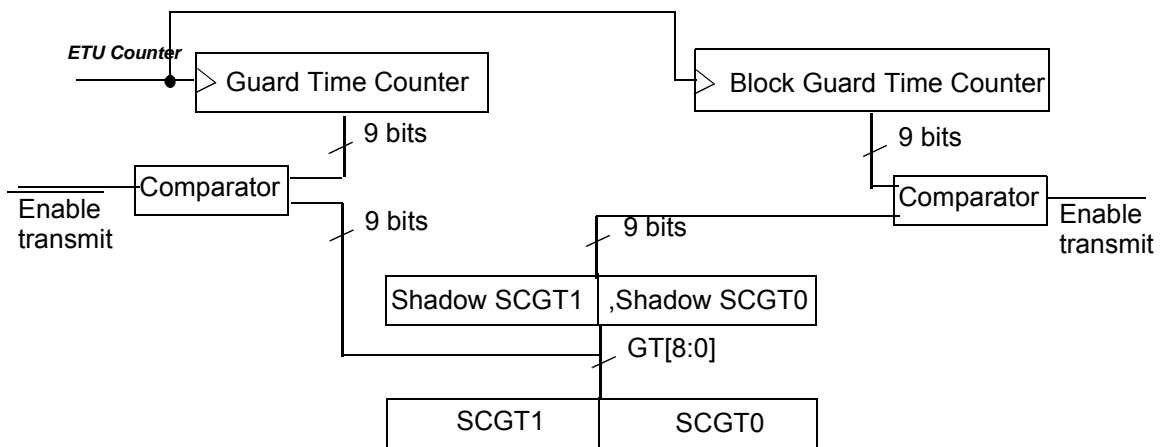

Figure 32. Guard Time and Block Guard Time counters



To illustrate the use of Guard Time and Block Guard Time, let us consider the ISO/IEC7816-3 recommendation : Guard Time = 2 (minimum delay between 2 consecutive characters sent by the Terminal = 12 ETUs), and Block Guard Time = 22 ETUs.

After A smart Card Reset

- Write 00decimal in SCGT1, Write 21decimal in SCGT0
- Set BGTEN in SCSR (BGTEN was 0 before as a result of the smart card reset)
- Write 12decimal in SCGT0

Now the Guard Time and Block Guard Time are properly initialized. The TERMINAL will insure a minimum 12 ETUs between 2 leading edges of 2 consecutive characters transmitted. The TERMINAL will also insure a minimum of 22 ETUs between the leading edge of a character sent by the ICC, and the leading edge of a character sent by the TERMINAL. There is no need to write SCGT1,0 again and again.

Waiting Time (WT) Counter

The WT counter is a 32 bits down counter which can be loaded with the value contained in the SCWT3, SCWT2, SCWT1, SCWT0 registers. Its main purpose is timeout signal generation. It is 32 bits wide and is decremented at the ETU rate. see Figure 33.

When the WT counter times out, an interrupt is generated and the SCIB function is locked: reception and emission are disabled. It can be enabled by resetting the macro or reloading the counter.

The Waiting Time Counter can be used in T=0 protocol for the Work Waiting Time. It can be used in T=1 protocol for the Character Waiting Time and for the Block Waiting Time. See the detailed explanation below.

Figure 33. Waiting Time Counter

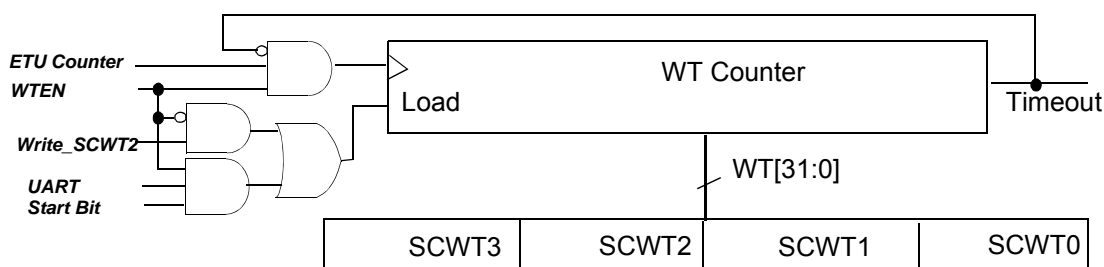

In the so called manual mode, the counter is loaded, if $WTEN = 0$, during the write of SCWT2 register. The counter is loaded with a 32 bit word built with SCWT3 SCWT2 SCWT1 SCWT0 registers (SCWT0 contain WT[7-0] byte). WTEN is located in the SCICR register.

When $WTEN=1$ and in UART mode, the counter is re-loaded at the occurrence of a start bit. This mode will be detailed below in T=0 protocol and T=1 protocol.

In manual mode, the WTEN signal controls the start of the counter (rising edge) and the stop of the counter (falling edge). After a timeout of the counter, a falling edge on WTEN, a reload of SCWT2 and a rising edge of WTEN are necessary to start again the counter and to release the SCIB macro. The reload of SCWT2 transfers all SCWT0, SCWT1, SCWT2 and SCWT3 registers to the WT counter.

In UART mode there is an automatic load on the start bit detection. This automatic load is very useful for changing on-the-fly the timeout value since there is a register to hold the load value. This is the case for T=1 protocol.

In T=0 protocol the maximum interval between the start leading edge of any character sent by the ICC and the start of the previous character sent by either the ICC or the Terminal is the maximum Work Waiting Time. The Work Waiting Time shall not exceed $960 \cdot D \cdot WI$ ETUs with D and WI parameters are returned by the field TA1 and TC2 respectively in the Answer To Reset (ATR). This is the value the user shall write in the SCWT0,1,2,3 register. This value will be reloaded in the Waiting Time counter every start bit.

Figure 34. T=0 mode

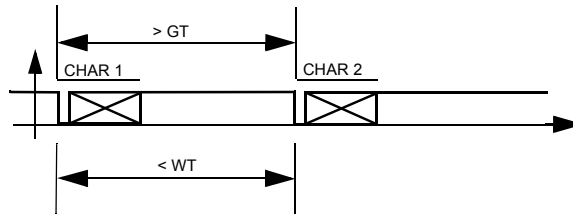

In T=1 protocol : The maximum interval between the leading edge of the start bit of 2 consecutive characters sent by the ICC is called maximum Character Waiting Time. The Character Waiting Time shall not exceed $(2^{**}CWI + 11)$ ETUs with $0 \leq CWI \leq 5$. Consequently $12 \text{ ETUs} \leq CWT \leq 43 \text{ ETUs}$.

T=1 protocol also specify the maximum Block Waiting Time. This is the time between the leading edge of the last character sent by the Terminal giving the right to send to the ICC, and the leading edge of the start bit of the first character sent by the ICC. The Block Waiting Time shall not exceed $(2^{**}BWI*960 + 11)$ ETUs with $0 \leq BWI \leq 4$. Consequently $971 \text{ ETUs} \leq BWT \leq 15371 \text{ ETUs}$.

In T=1 protocol it is possible to extend the Block Waiting Time with the Waiting Time Extension (WTX). When selected the waiting time becomes $BWT*WTX$ ETUs. The Waiting Time counter is 32 bit wide to accomodate this feature.

It is possible to take advantage of the automatic reload of the Waiting Time counter with a start bit in UART mode (T=1 protocol use UART mode) . If the Terminal sends a block of N characters, and the ICC is supposed to respond immediately after, then the following sequence can be used.

While sending the (N-1)th character of the block, the Terminal can write the SCWT0,1,2,3 with BWI_{max} .

At the start bit of the Nth character, the BWI_{max} is loaded in the Waiting Time counter

During the transmission of the Nth character, the Terminal can write SCWT0,1,2,3 with the CWI_{max} .

At the start bit of the first character sent by the ICC, the CWI_{max} will be loaded in the Waiting Time counter.

Figure 35. T=1 Mode

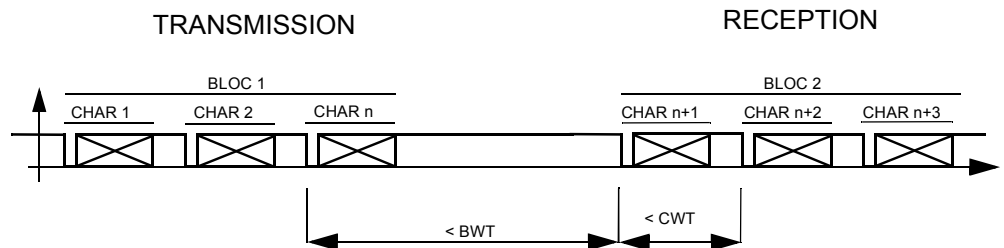

Power-on and Power-off FSM

The Power-on Power-off Finite State Machine (FSM) applies the signals on the smart card in accordance with ISO7816-3 standard. It conducts the Activation (Cold Reset and Warm Reset as well as De-Activation) it also manages the exception conditions such as overcurrent (see DC/DC Converter)

To be able to power on the SCIB, the card presence is mandatory. Upon detection of a card presence, the Terminal initiate a Cold Reset Activation.

The Cold Reset Activation Terminal procedure is as follow and the Figure 36. Timing indications are given according to ISO IEC 7816

- RESET= Low , I/O in the receive state
- Power Vcc (see DC/DC Converter)
- Once Vcc is established, apply Clock at time T_a
- Maintain Reset Low until time T_a+t_b ($t_b < 400$ clocks)
- Monitor The I/O line for the Answer To Reset (ATR) between 400 and 40000 clock cycles after T_b . ($400 \text{ clocks} < t_c < 40000 \text{ clocks}$)

Figure 36. SCIB Activation Cold Reset Sequence after a Card Insertion

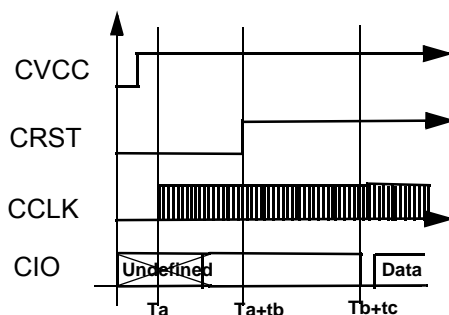

The Warm Reset Activation Terminal procedure is as follow and the Figure 37

- Vcc active, Reset = High, CLK active
- Terminal drive Reset low at time T to initiate the warm Reset. Reset=0 maintained for at least 400 clocks until time $T_d = T+t_e$ ($400 \text{ clocks} < t_e$)
- Terminal keep the IO line in receive state
- Terminal drive Reset high after at least 400 clocks at time T_d
- ICC shall respond with an ATR within 40000 clocks ($t_f < 40000 \text{ clocks}$)

Figure 37. SCIB Activation Warm Reset Sequence

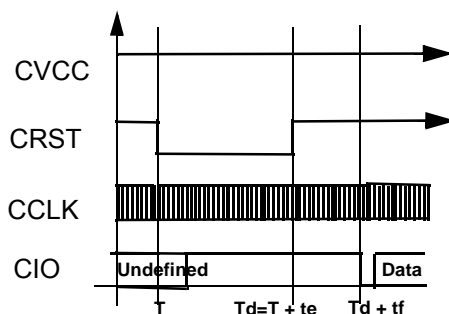

Removal of the smart card will automatically start the power off sequence as described in Figure 38.

The SCIB deactivation sequence after a reset of the CPU or after a lost of power supply is ISO7816-3 compliant. The switching order of the signals is the same as in Figure 38 but the delay between signals is analog and not clock dependant.

Figure 38. SCIB Deactivation Sequence after a Card Extraction

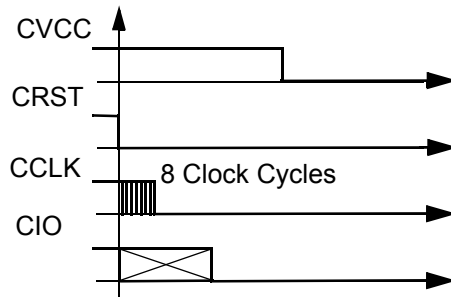

Interrupt Generator

There are several sources of interruption but the SCIB macro-cell issues only one interrupt signal: SCIBIT.

Figure 39. SCIB Interrupt Sources

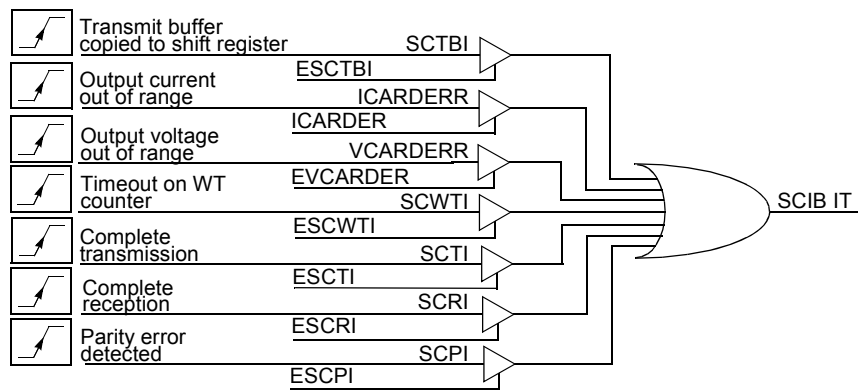

This signal is high level active. Each of the sources is able to activate the SCIB interruption which is cleared when the Smart Card Interrupt register is read by the microcontroller.

If during the read of the Smart Card Interrupt register another interrupt occurs, the activation of the corresponding bit in the Smart Card Interrupt register and the new SCIB interruption is delayed until the interrupt register is read by the microcontroller.

Warning : Each bit of the SCIIR register is irrelevant while the corresponding interruption is disabled in SCIER register. When the interruption mode is not used, the bits of the SCISR register must be used instead of the bits of the SCIIR register.

Additional Features

Clock

The CK_ISO input must be in the range 1 - 5 MHz according to ISO 7816.

The CK_ISO can be programmed up to 12 MHz. In this case, the timing specification of the output buffer will not comply to ISO 7816.

Figure 40. Clock Diagram of the SCIB Block

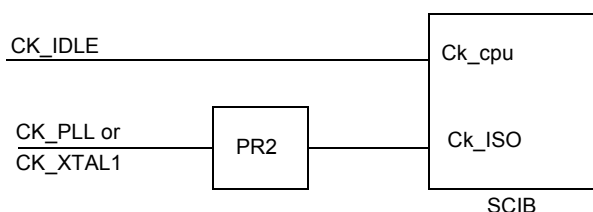
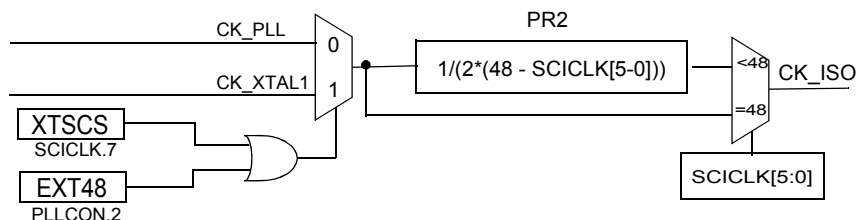

Figure 41. Prescaler 2 Description



The division factor SCICLK must be smaller than 49. If it is greater or equal to 49, the PR2 prescaler is locked.

See Figure 17 clock tree diagram in the clock controller chapter.

Table 42. Examples of Clock settings

XTAL1 (MHz)	EXT48	SCICLK	CK_ISO
8	0	36	4
8	0	44	12
8	0	42	8
8	0	40	6
8	0	24	2
8	0	0	1

Card Presence Input

The internal pull-up (weak pull-up) on Card Presence input can be disconnected in order to reduce the consumption (CPRESRES, bit 3 in PMOD0).

In this case, an external resistor (typically 1 M Ω) must be externally tied to Vcc.

CPRES input can generate an interrupt (see Interrupt system section).
The detection level can be selected.

Transmit / Receive Buffer

The contents of the SCIBUF Transmit / Receive Buffer is transferred or received into / from the Shift Register. The Shift Register is not accessible by microcontroller. Its role is to prepare the byte to be copied on the I/O pin for a transmission or in the SCIBUF buffer after a reception.

During a character transmission process, as soon as the contents of the SCIBUF buffer is transferred to the shift register, the SCTBE bit is set in SCISR register to indicate that the SCIBUF buffer is empty and ready to accept a new byte. This mechanism avoids to wait for the complete transmission of the previous byte before writing a new byte in the buffer and enables to speed up the transmission.

- If the Character repetition mode is not selected (bit CREP=0 in SCICR), as soon as the contents of the Shift Register is transferred to I/O pin, the SCTC bit is set in SCISR register to indicate that the byte has been transmitted.
- If the Character repetition mode is selected (bit CREP=1 in SCICR) The TERMINAL will be able to repeat characters as requested by the ICC (See the Parity Error in T=0 protocol description in the definition paragraph above). The SCTC bit in SCISR register will be set after a successful transmission (no retry or no further retry requested by the ICC). If the number of retries is exhausted (up to 4 retries depending on CREPSEL bit in SCSR) and the last retry is still unsuccessful, the SCTC bit in SCISR will not be set and the SCPE bit in SCISR register will be set instead.

During a character reception process, the contents of the Shift Register is transferred in the SCIBUF buffer.

- If the Character repetition mode is not selected (bit CREP=0 in SCICR), as soon as the contents of the Shift Register is transferred to the SCIBUF the SCRC bit is set in SCISR register to indicate that the byte has been received, and the SCIBUF contains a valid character ready to be read by the microcontroller.
- If the Character repetition mode is selected (bit CREP=1 in SCICR) The TERMINAL will be able to request repetition if the received character exhibit a parity error. Up to 4 retries can be requested depending on CREPSEL bit in SCSR. The SCRC bit will be set in SCISR register after a successful reception, first reception or after retry(ies). If the number of retries is exhausted (up to 4 retries depending on CREPSEL bit in SCSR) and the last retry is still unsuccessful, the SCRC bit and the SCPE bit in SCISR register will be set. It will be possible to read the erroneous character.

Warning : the SCTBI, SCTI, SCRI and SCPI bits have the same function as SCTBE, SCTC, SCRC and SCPE bits. The first ones are able to generate interruptions if the interruptions are enabled in SCIER register while the second ones are only status bits to be used in pulling mode. If the interruption mode is not used, the status bits must be used. The SCTBI, SCTI and SCRI bits do not contain valid information while their respective interrupt enable bits ESCTBI, EXCTI, ESCRI are cleared.

Figure 43. Character Reception Diagram

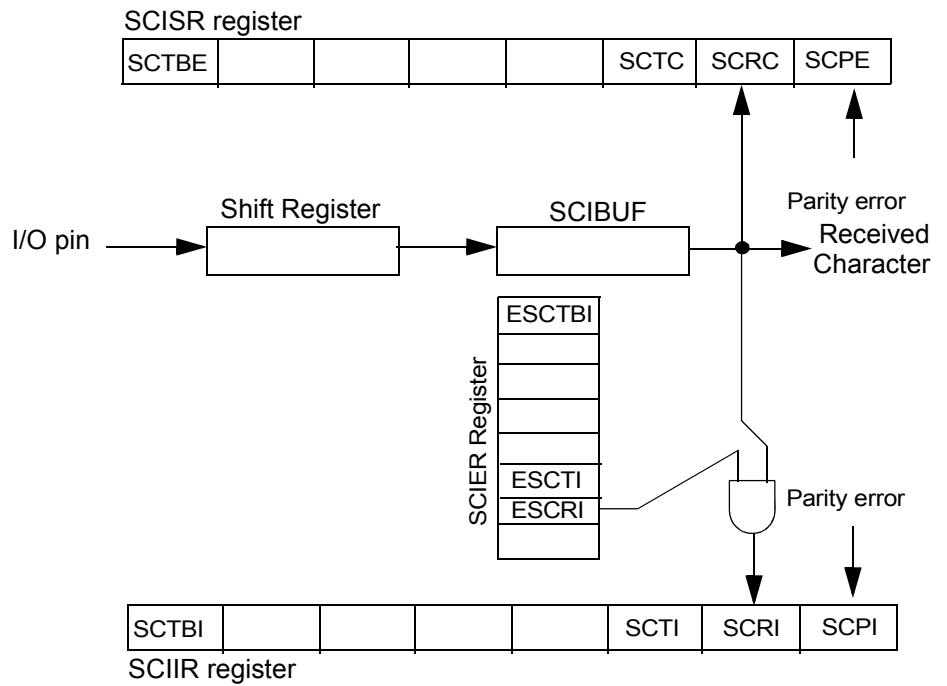

SCIB Reset

The SCICR register contains a reset bit. If set, this bit generates a reset of the SCIB and its registers. Table 43 defines the SCIB registers that are reset and their reset values.

Table 43. Reset Values for SCI Registers

Register Name	SCIB Reset Value (Binary)
SCICR	0000 0000
SCCON	0X00 0000
SCISR	1000 0000
SCIIR	0X00 0000
SCIER	0X00 0000
SCSR	X000 1000
SCIBUF	0000 0000
SCETU1, SCETU0	XXXX X001, 0111 0100 (372)
SCGT1, SCGT0	0000 0000, 0000 1100 (12)
SCWT3, SCWT2, SCWT1, SCWT0	0000 0000, 0000 0000, 0010 0101, 1000 0000 (9600)
SCICLK	0X10 1111

Alternate Card

A second card named 'Alternate Card' can be controlled.

The Clock signal CCLK1 can be adapted to the XTAL frequency. Thanks to the clock prescaler which can divide the frequency by 1, 2, 4 or 8. The bits ALTKPS0 and ALTKPS1 in SCSR Register are used to set this factor.

Figure 44. Alternate Card

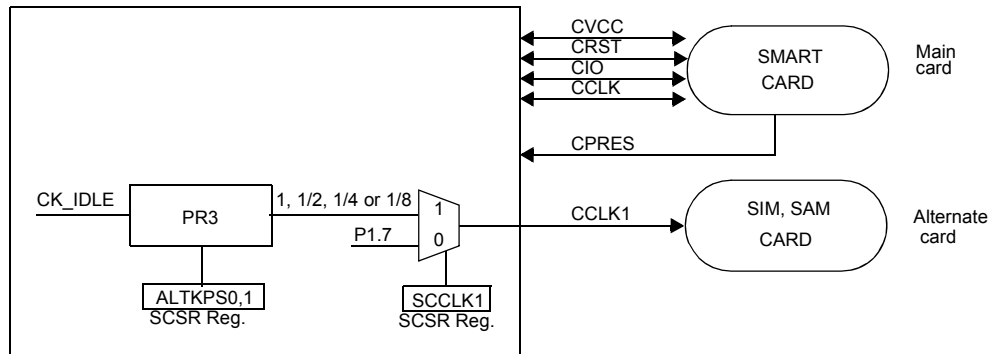

Registers

There are fifteen registers to control the SCIB macro-cell. They are described from Table 58 to Table 45.

Some of the register widths are greater than a byte. Despite the 8 bits access provided by the BIU, the address mapping of this kind of register respects the following rule :

The Low significant byte register is implemented at the higher address.

This implementation makes access to these registers easier when using high level programming languages (C,C++).

Table 44. Smart Card Interface Control Register - SCICR (S:B6h, SCRS = 1)

7	6	5	4	3	2	1	0
RESET	CARDDET	VCARD1	VCARD0	UART	WTEN	CREP	CONV

Bit Number	Bit Mnemonic	Description															
7	RESET	<p>Reset Set this bit to reset and deactivate the Smart Card Interface. Clear this bit to activate the Smart Card Interface. This bit acts as an active high software reset.</p>															
6	CARDDET	<p>Card Presence Detector Sense Clear this bit to indicate the card presence detector is open when no card is inserted (CPRES is high). Set this bit to indicate the card presence detector is closed when no card is inserted (CPRES is low).</p>															
5-4	VCARD[1:0]	<p>Card Voltage Selection:</p> <table style="margin-left: 20px; border-collapse: collapse;"> <tr> <td style="border-bottom: 1px solid black; padding: 2px;">VCARD[1]</td> <td style="border-bottom: 1px solid black; padding: 2px;">VCARD[0]</td> <td style="border-bottom: 1px solid black; padding: 2px;">CVCC</td> </tr> <tr> <td style="padding: 2px;">0</td> <td style="padding: 2px;">0</td> <td style="padding: 2px;">0 V</td> </tr> <tr> <td style="padding: 2px;">0</td> <td style="padding: 2px;">1</td> <td style="padding: 2px;">1.8 V</td> </tr> <tr> <td style="padding: 2px;">1</td> <td style="padding: 2px;">0</td> <td style="padding: 2px;">3.0 V</td> </tr> <tr> <td style="padding: 2px;">1</td> <td style="padding: 2px;">1</td> <td style="padding: 2px;">5.0 V</td> </tr> </table>	VCARD[1]	VCARD[0]	CVCC	0	0	0 V	0	1	1.8 V	1	0	3.0 V	1	1	5.0 V
VCARD[1]	VCARD[0]	CVCC															
0	0	0 V															
0	1	1.8 V															
1	0	3.0 V															
1	1	5.0 V															
3	UART	<p>Card UART Selection Clear this bit to use the CARDIO bit (P1.0) bit to drive the Card I/O (P1.0) pin. Set this bit to use the Smart Card UART to drive the Card I/O pin (P1.0) pin. Controls also the Waiting Time Counter as described in Section "Waiting Time (WT) Counter", page 67</p>															
2	WTEN	<p>Waiting Time Counter Enable Clear this bit to stop the counter and enable the load of the Waiting Time counter hold registers. The hold registers are loaded with SCWT0, SCWT1, SCWT2 and SCWT3 values when SCWT2 is written. Set this bit to start the Waiting Time Counter. The counters stop when it reaches the timeout value. If the UART bit is set, the Waiting Time Counter automatically reloads with the hold registers whenever a start bit is sent or received.</p>															
1	CREP	<p>Character Repetition Clear this bit to disable parity error detection and indication on the Card I/O pin in receive mode and to disable character repetition in transmit mode. Set this bit to enable parity error indication on the Card I/O pin in receive mode and to set automatic character repetition when a parity error is indicated in transmit mode. Depending upon CREPSET bit in SCSR register, the receiver can indicate parity error up to 4times (3 repetitions) or up to 5times (4 repetitions) after which it will raise the parity error bit SCPE bit in the SCISR register. If parity interrupt is enabled, the SCPI bit in SCIIR register will be set too. Alternately, the transmitter will detect ICC character repetition request. After 3 or 4 unsuccessful repetitions (depending on CREPSEL bit in SCSR register), the transmitter will raise the parity error bit SCPE bit in the SCISR register. If parity interrupt is enabled, the SCPI bit in SCIIR register will be set too. Note : Character repetition mode is specified for T=0 protocol only and should not be used in T=1 protocol (block oriented protocol)</p>															
0	CONV	<p>ISO Convention Clear this bit to use the direct convention: b0 bit (LSB) is sent first, the parity bit is added after b7 bit and a low level on the Card I/O pin represents a'0'. Set this bit to use the inverse convention: b7 bit (LSB) is sent first, the parity bit is added after b0 bit and a low level on the Card I/O pin represents a'1'.</p>															

Reset Value = 0000 0000b



Table 45. Smart Card Contacts Register - SCCON (S:ACh, SCRS=0)

7	6	5	4	3	2	1	0
CLK	-	CARDC8	CARDC4	CARDIO	CARDCLK	CARDRST	CARDVCC
Bit Number	Bit Mnemonic	Description					
7	CLK	Card Clock Selection Clear this bit to use the Card CLK bit (CARDCLK bit below) to drive Card CLK (P1.4) pin. Set this bit to use CK_XTAL1 or CK_PLL signals for CK_ISO to drive the Card CLK pin (CCLK = P1.4 pin) Note: internal synchronization avoids glitches on the CLK pin when switching this bit.					
6	-	Reserved This bit can be changed by software but the read value is indeterminate.					
5	CARDC8	Card C8 Clear this bit to drive a low level on the Card C8 pin (CC8 = P1.1 pin). Set this bit to set a high level on the Card C8 pin (CC8 = P1.1 pin).. The CC8 pin can be used as a pseudo bi-directional I/O when this bit is set. Warning : VCARDOK=1 (SCISR.4 bit) condition must be true to change the state of CC8 pin					
4	CARDC4	Card C4 Clear this bit to drive a low level on the Card C4 pin (CC4 = P1.3 pin). Set this bit to set a high level on the Card C4 pin (CC4 = P1.3 pin). The CC4 pin can be used as a pseudo bi-directional I/O when this bit is set. Warning : VCARDOK=1 (SCISR.4 bit) condition must be true to change the state of CC4 pin					
3	CARDIO	Card I/O If UART bit is cleared in SCICR register, this bit enables the use of the Card IO pin (CIO = P1.0) as a C51 pseudo bi-directional port : To read from CIO (P1.0) port pin : set CARDIO (P1.0) bit then read CARDIO (P1.0) bit to have the CIO port value To write in CIO (P1.0) port pin : set CARDIO (P1.0) bit to write a 1 in CIO (P1.0) port pin , clear CARDIO (P1.0) bit to write a 0 in CIO (P1.0) port pin. Warning : VCARDOK=1 (SCISR.4 bit) condition must be true to change the state of CIO pin					
2	CARDCLK	Card CLK When the CLK bit is cleared in SCCON Register, the value of this bit is driven to the Card CLK pin. Warning : VCARDOK=1 (SCISR.4 bit) condition must be true to change the state of Card CLK pin					
1	CARDRST	Card RST Clear this bit to drive a low level on the Card RST pin. Set this bit to set a high level on the Card RST pin. Warning : VCARDOK=1 (SCISR.4 bit) condition must be true to change the state of Card RST pin					
0	CARDVCC	Card VCC Control Clear this bit to deactivate the Card interface and set its power-off. The other bits of SCCON register have no effect while this bit is cleared. Set this bit to power-on the Card interface. The activation sequence should be handled by software.					

Reset Value = 0X00 0000b

Table 46. Smart Card UART Interface Status Register - SCISR (S:ADh, SCRS=0)

7	6	5	4	3	2	1	0
SCTBE	CARDIN	ICARDOVF	VCARDOK	SCWTO	SCTC	SCRC	SCPE
Bit Number	Bit Mnemonic	Description					
7	SCTBE	UART Transmit Buffer Empty Status This bit is set by hardware when the Transmit Buffer is copied to the transmit shift register of the Smart Card UART. It is cleared by hardware when SCIBUF register is written.					
6	CARDIN	Card Presence Status This bit is set by hardware if there is a card presence (debouncing filter has to be done by software). This bit is cleared by hardware if there is no card presence.					
5	ICARDOVF	Card Current Overflow Status This bit is set when the current on card is above the limit specified by bit OVFADJ in DCCKPS register (Table 61 on page 92) It is cleared by hardware.					
4	VCARDOK	Card Voltage Correct Status This bit is set when the output voltage is within the voltage range specified by VCARD[1:0] in SCICR register. It is cleared otherwise.					
3	SCWTO	Waiting Time Counter Timeout Status This bit is set by hardware when the Waiting Time Counter has expired. It is cleared by the reload of the counter or by the reset of the SCIB.					
2	SCTC	UART Transmitted Character Status This bit is set by hardware when the Smart Card UART has transmitted a character. If character repetition mode is selected, this bit will be set only after a successful transmission. If the last allowed repetition is not successful, this bit will not be set. It is cleared by software when this register is read.					
1	SCRC	UART Received Character Status This bit is set by hardware when the Smart Card UART has received a character It is cleared by hardware when SCIBUF register is read. If character repetition mode is selected, this bit will be set only after a successful reception. If the last allowed repetition is still unsuccessful, this bit will be set to let the user read the erroneous value if necessary.					
0	SCPE	Character Reception Parity Error Status This bit is set when a parity error is detected on the received character. It is cleared by software when this register is read. If character repetition mode is selected, this bit will be set only if the ICC report an error on the last allowed repetition of a TERMINAL transmission, or if a reception parity error is found on the last allowed ICC character repetition.					

Reset Value = 1000 0000b



Table 47. Smart Card UART Interrupt Identification Register (Read Only)
SCIIR (S:AEh, SCRS=0)

7	6	5	4	3	2	1	0
SCTBI	-	ICARDERR	VCARDERR	SCWTI	SCTI	SCRI	SCPI
Bit Number	Bit Mnemonic	Description					
7	SCTBI	UART Transmit Buffer Empty Interrupt This bit is set by hardware when the Transmit Buffer is copied into the transmit shift register of the Smart Card UART. It generates an interrupt if ESCTBI bit is set in SCIER register otherwise this bit is irrelevant. It is cleared by hardware when this register is read.					
6	-	Reserved The value read from this bit is indeterminate. Do not change this bit.					
5	ICARDERR	Card Current Overflow Interrupt This bit is set when the current on card is above the limit specified by bit OVFAJ in DCCKPS register (Table 61 on page 92). It generates an interrupt if ICARDERR bit is set in SCIER register otherwise this bit is irrelevant. It is cleared by hardware when this register is read.					
4	VCARDERR	Card Voltage Error Interrupt This bit is set when the output voltage goes out of the voltage range specified by VCARD field. It generates an interrupt if EVCARDERR bit is set in SCIER register otherwise this bit is irrelevant. It is cleared by hardware when this register is read.					
3	SCWTI	Waiting Time Counter Timeout Interrupt This bit is set by hardware when the Waiting Time Counter has expired. It generates an interrupt if ESCWTI bit is set in SCIER register otherwise this bit is irrelevant. It is cleared by hardware when this register is read.					
2	SCTI	UART Transmitted Character Interrupt This bit is set by hardware when the Smart Card UART has completed the character transmission. It generates an interrupt if ESCTI bit is set in SCIER register otherwise this bit is irrelevant. It is cleared by hardware when this register is read.					
1	SCRI	UART Received Character Interrupt This bit is set by hardware when the Smart Card UART has completed the character reception. It generates an interrupt if ESCRI bit is set in SCIER register otherwise this bit is irrelevant. It is cleared by hardware when this register is read.					
0	SCPI	Character Reception Parity Error Interrupt This bit is set at the same time as SCTI or SCRI if a parity error is detected on the received character. It generates an interrupt if ESCPI bit is set in SCIER register otherwise this bit is irrelevant. It is cleared by hardware when this register is read.					

Reset Value = 0X00 0000b

- Note:
- 1) In case of multiple interrupts occurring at the same time (sampled by the same edge of the internal clock), the interrupts will be serviced in the following order from the highest to the lowest priority :
 - UART Transmit Buffer Empty
 - Card Current Overflow
 - Card Voltage Error
 - Waiting Time Counter Timeout
 - UART Transmitted Character
 - UART Received Character
 - Character Reception Parity Error

2) It is recommended that the application saves the SCIIR register after reading it in order to avoid the loss of pending interruptions as the SCIIR register is cleared when it is read by the MCU.

Table 48. Smart Card UART Interrupt Enabling Register - SCIER (S:AEh, SCRS=1)

7	6	5	4	3	2	1	0
ESCTBI	-	ICARDER	EVCARDER	ESCWTI	ESCTI	ESCRI	ESCPI
Bit Number	Bit Mnemonic	Description					
7	ESCTBI	UART Transmit Buffer Empty Interrupt Enabled Clear this bit to disable the Smart Card UART Transmit Buffer Empty interrupt. Set this bit to enable the Smart Card UART Transmit Buffer Empty interrupt.					
6	-	Reserved The value read from this bit is indeterminate. Do not change this bit.					
5	ICARDER	Card Current Overflow Interrupt Enabled Clear this bit to disable the Card Current Overflow interrupt. Set this bit to enable the Card Current Overflow interrupt.					
4	EVCARDER	Card Voltage Error Interrupt Enabled Clear this bit to disable the Card Voltage Error interrupt. Set this bit to enable the Card Voltage Error interrupt.					
3	ESCWTI	WaitingTime Counter Timeout Interrupt Enabled Clear this bit to disable the Waiting Time Counter timeout interrupt. Set this bit to enable the Waiting Time Counter timeout interrupt.					
2	ESCTI	UART Transmitted Character Interrupt Enabled Clear this bit to disable the Smart Card UART Transmitted Character interrupt. Set this bit to enable the Smart Card UART Transmitted Character interrupt.					
1	ESCRI	UART Received Character Interrupt Enabled Clear this bit to disable the Smart Card UART Received Character interrupt. Set this bit to enable the Smart Card UART Received Character interrupt.					
0	ESCPI	Character Reception Parity Error Interrupt Enabled Clear this bit to disable the Smart Card Character Reception Parity Error interrupt. Set this bit to enable the Smart Card Character Reception Parity Error interrupt.					

Reset Value = 0X00 0000b



Table 49. Smart Card Selection Register - SCSR (S:ABh)

7	6	5	4	3	2	1	0
-	BGTEN	-	CREPSEL	ALTKPS1	ALTKPS0	SCCLK1	SCRS
Bit Number	Bit Mnemonic	Description					
7	-	Reserved The value read from this bit is indeterminate. Do not change this bit.					
6	BGTEN	Block Guard Time Enable Set this bit to select the minimum interval between the leading edge of the start bits of the last character received from the ICC and the first character sent by the Terminal. The transfer of GT[8-0] value to the BGT counter is done on the rising edge of the BGTEN. Clear this bit to suppress the minimum time between reception and transmission.					
5	-	Reserved The value read from this bit is indeterminate. Do not change this bit.					
4	CREPSEL	Character repetition selection Clear this bit to select 5 times transmission (1 original + 4 repetitions) before parity error indication (conform to EMV) Set this bit to select 4 times transmission (1 original + 3 repetitions) before parity error indication					
3-2	ALTKPS1:0	Alternate Card Clock prescaler factor 00 ALTKPS = 0: prescaler factor equals 1 01 ALTKPS = 1: prescaler factor equals 2 10 ALTKPS = 2: prescaler factor equals 4 (reset value) 11 ALTKPS = 3: prescaler factor equals 8					
1	SCCLK1	Alternate card clock selection Set to select the prescaled PR3 clock for CCLK1 (P1.7) pin Clear to select P1.7 port bit					
0	SCRS	Smart Card Register Selection The SCRS bit selects which set of the SCIB registers is accessed.					

Reset Value = X000 1000b

Table 50. Smart Card Transmit / Receive Buffer - SCIBUF (S:AA)

7	6	5	4	3	2	1	0
-	-	-	-	-	-	-	-
Bit Number	Bit Mnemonic	Description					
-	-	Smart Card Transmit / Receive Buffer - A new byte can be written in the buffer to be transmitted on the I/O pin when SCTBE bit is set. The bits are sorted and copied on the I/O pin versus the active convention. - A new byte received from I/O pin is ready to be read when SCRI bit is set. The bits are sorted versus the active convention.					

Reset Value = 0000 0000b

Table 51. Smart Card ETU Register 1 - SCETU1 (S:ADh, SCRS=1)

7	6	5	4	3	2	1	0	
COMP	-	-	-	-	ETU10	ETU9	ETU8	
Bit Number	Bit Mnemonic	Description						
7	COMP	Compensation Clear this bit when no time compensation is needed (i.e. when the ETU to Card CLK period ratio is close to an integer with an error less than 1/4 of Card CLK period). Set this bit otherwise and reduce the ETU period by 1 Card CLK cycle for even bits.						
6-3	-	Reserved The value read from these bits is indeterminate. Do not change these bits.						
2-0	ETU[10:8]	ETU MSB Used together with the ETU LSB in SCETU0 (Table 52) Warning : the ETU counter is reloaded at each register's write operation. Do not change this register during character reception or transmission or while Guard Time or Waiting Time Counters are running.						

Reset Value = 0XXX X001b

Table 52. Smart Card ETU Register 0 - SCETU0 (S:ACh, SCRS=1)

7	6	5	4	3	2	1	0	
ETU7	ETU6	ETU5	ETU4	ETU3	ETU2	ETU1	ETU0	
Bit Number	Bit Mnemonic	Description						
7 - 0	ETU[7:0]	ETU LSB The Elementary Time Unit is $(ETU[10:0] - 0.5 \cdot COMP) / f$, where f is the Card CLK frequency. According to ISO 7816, ETU[10:0] can be set between 11 and 2048. The default reset value of ETU[10:0] is 372 (F=372, D=1).						

Reset Value = 0111 0100b



Table 53. Smart Card Transmit Guard Time Register 0 - SCGT0 (S:B4h, SCRS=1)

7	6	5	4	3	2	1	0
GT7	GT6	GT5	GT4	GT3	GT2	GT1	GT0
Bit Number	Bit Mnemonic	Description					
7 - 0	GT[7:0]	Transmit Guard Time LSB The minimum time between two consecutive start bits in transmit mode is GT[8:0] * ETU. This is equal to ISO IEC Guard Time +10 (see Guard Time Counter description). According to ISO IEC 7816, the time between 2 consecutive leading edge start bits can be set between 11 and 266 (11 to 254+12 ETUs).					

Reset Value = 0000 1100b

Table 54. Smart Card Transmit Guard Time Register 1 - SCGT1 (S:B5h, SCRS=1)

7	6	5	4	3	2	1	0
-	-	-	-	-	-	-	GT8
Bit Number	Bit Mnemonic	Description					
7 - 1	-	Reserved The value read from these bits is indeterminate. Do not change these bits.					
0	GT8	Transmit Guard Time MSB Used together with the Transmit Guard Time LSB in SCGT0 register (Table 53).					

Reset Value = XXXX XXX0b

Table 55. Smart Card Character/Block Waiting Time Register 3
SCWT3 (S:C1h, SCRS=0)

7	6	5	4	3	2	1	0
WT31	WT30	WT29	WT28	WT27	WT26	WT25	WT24
Bit Number	Bit Mnemonic	Description					
7 - 0	WT[31:24]	Waiting Time Byte3 Used together with WT[23:0] in registers SCWT2, SCWT1, SCWT0 (see Table 56).					

Reset Value = 0000 0000b

Table 56. Smart Card Character/Block Waiting Time Register 2
SCWT2 (S:B6h, SCRS=0)

7	6	5	4	3	2	1	0
WT23	WT22	WT21	WT20	WT19	WT18	WT17	WT16
Bit Number	Bit Mnemonic	Description					
7 - 0	WT[23:16]	Waiting Time Byte2 Used together with WT[31:24] and WT[15:0] in registers SCWT3,SCWT1, SCWT0 (see Table 58).					

Reset Value = 0000 0000b

Table 57. Smart Card Character/Block Waiting Time Register 1
SCWT1 (S:B5h, SCRS=0)

7	6	5	4	3	2	1	0
WT15	WT14	WT13	WT12	WT11	WT10	WT9	WT8
Bit Number	Bit Mnemonic	Description					
7 - 0	WT[15:8]	Waiting Time Byte 1 Used together with WT[31:16] and WT[7:0] in registers SCWT3,SCWT2, SCWT0 (see Table 55).					

Reset Value = 0010 0101b

Table 58. Smart Card Character/Block Waiting Time Register 0
SCWT0 (S:B4h, SCRS=0)

7	6	5	4	3	2	1	0
WT7	WT6	WT5	WT4	WT3	WT2	WT1	WT0
Bit Number	Bit Mnemonic	Description					
7 - 0	WT[7:0]	Waiting Time Byte 0 WT[31:0] is the reload value of the Waiting Time Counter (WTC). The WTC is a general-purpose timer. It is using the ETU clock and is controlled by the WTEN bit (see Table 44 on page 77 and Section "Waiting Time (WT) Counter", page 67). When UART bit of Registers is set, the WTC is automatically reloaded at each start bit of the UART. It is used to check the maximum time between to consecutive start bits.					

Reset Value = 1000 0000b

Table 59. Smart Card Clock Reload Register - SCICLK (S:C1h, SCRS=1)

7	6	5	4	3	2	1	0
XTSCS	-	SCICLK5	SCICLK4	SCICLK3	SCICLK2	SCICLK1	SCICLK0
Bit Number	Bit Mnemonic	Description					
7	XTSCS	Smart Card Clock Selection Bit If XTSCS bit is set OR EXT48 bit is set (in PLLCON register) , CK_PLL is used to generate CK_ISO. Otherwise, CK_XTAL1 is used to generate CK_ISO. See the Clock Tree diagram figure 17.					
6	-	Reserved The value read from this bit is indeterminate. Do not change these bits.					
5 - 0	SCICLK[5:0]	SCIB clock reload register Prescaler 2 reload value is used to defines the card clock frequency. If SCICLK[5:0] is smaller than 48 : $Fck_iso = Fck_pll \text{ or } Fck_XTAL1 / (2 * (48 - SCICLK[5:0]))$ If SCICLK[5:0] is equal to 48 : $Fck_iso = Fck_XTAL1$ SCICLK[5:0] must be smaller than 49.					

Reset Value = 0X10 1111b (default value for a divider by two)

DC/DC Converter

The Smart Card voltage (CVCC) is supplied by the integrated DC/DC converter which is controlled by several registers:

- The SCICR register (Table 44 on page 77) controls the CVCC level by means of bits VCARD[1:0].
- The SCCON register (Table 45 on page 78) enables to switch the DC/DC converter on or off by means of bit CARDVCC.
- The DCCKPS register (Table 61 on page 92) controls the DC/DC clock and current.

The DC/DC converter cannot be switched on while the CPRES pin remains inactive. If CPRES pin becomes inactive while the DC/DC converter is operating an automatic shut down sequence of the DC/DC converter is initiated by the electronics.

It is mandatory to switch off the DC/DC Converter before entering in Power-down mode.

Configuration

The DC/DC Converter can work in two different modes which are selected by bit MODE in DCCKPS register:

- Pump Mode: an external inductance of 10 μ H must be connected between pins LI and VCC. VCC can be higher or lower than CVCC.
- Regulator mode : no external inductance is required but VCC must be always higher than CVCC+0.3V. The Regulation mode will work even if an external inductance of 10 μ H is connected between pins LI and VCC

The DC/DC clock prescaler which is controlled by bits DCCKPS[3:0], in DCCKPS register must be configured to set the DC/DC clock to a working frequency of 4 MHz which depends upon the value of the crystal. There is no need to change the default configuration set by the reset sequence if an 8 MHz crystal is used by the application.

The DC/DC Converter implements a current overflow controller which avoids permanent damage of the DC/DC converter in case of short circuit between CVCC and CVSS. The maximum limit is around 100 mA. It is possible to increase this limit in normal operating

mode by 20% by means of bit OVFADJ in DCCKPS register. When the current overflow controller is operating, the ICARDOVF is set by the hardware in SCISR register.

The current drawn from power supply by the DC/DC converter is controlled during the startup phase in order to avoid high transient current mainly in Pump Mode which could cause the power supply voltage to drop dramatically. This control is done by means of bits BOOST[1:0], which increases progressively the startup current level.

Initialization Procedure

The initialization procedure is different depending upon the required Card Vcc. One procedure apply for Card Vcc =< 3 volts and one procedure for Card Vcc = 5 volts.

The initialization procedure involves :

- Select the CVCC level by means of bits VCARD[1:0] in SCICR register,
- Set bits BOOST[1:0] in DCCKPS register following the current level control wanted.
- Switch the DC/DC on by means of bit CARDVCC in SCCON register,
- Monitor bit VCARDOK in SCISR register in order to know when the DC/DC Converter is ready (CVCC voltage has reached the expected level)

Procedure for CVcc =< 3 volts

The DC/DC regulation mode must be selected for Card Vcc = 1.8 volts and Card Vcc = 3 volts (MODE = 1 in DCCKPS register) The detailed procedures is described in flow chart of Figure 45. for Card Vcc = 1.8 volts and in the flow chart of Figure 46. for Card Vcc = 3 volts

Figure 45. Card Vcc = 1.8V Initialization Procedure

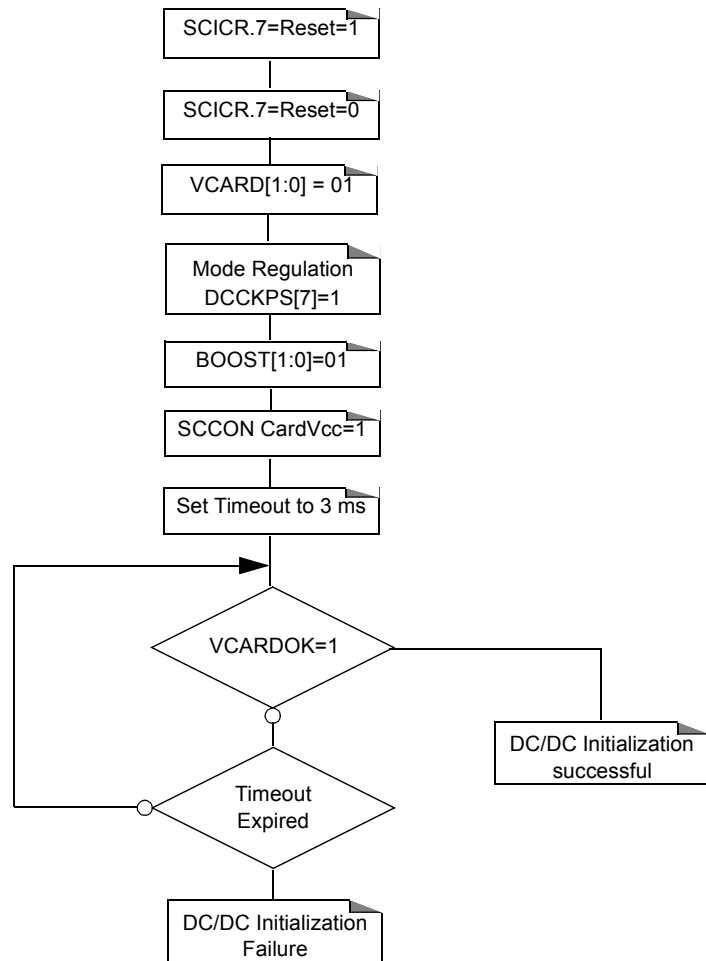
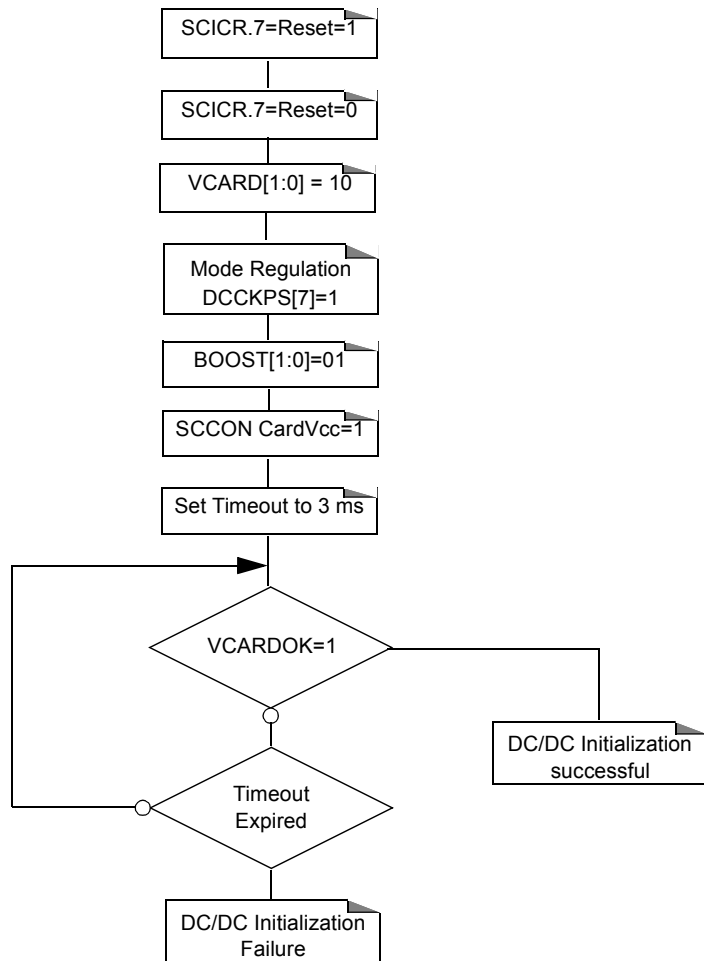

Figure 46. Card Vcc = 3V Initialization Procedure



Procedure for CVcc = 5volts

The DC/DC pump mode must be selected (MODE = 0 in DCCKPS register). The detailed procedure is described in flow chart of Figure 47.

Figure 47. Card Vcc = 5V Initialization Procedure

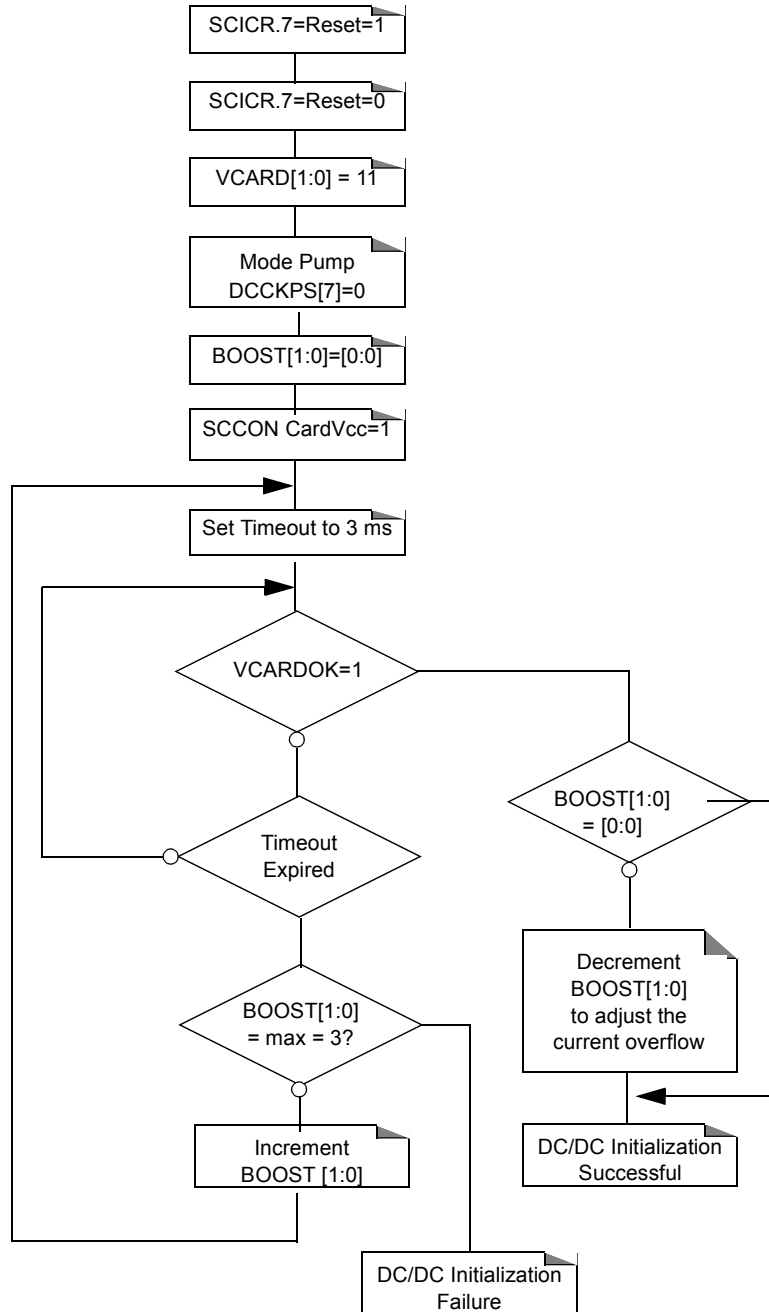

While VCC remains higher than 4.0V and startup current lower than 30 mA (depending on the load type), the DC/DC converter should be ready without having to increment BOOST[1:0] bits beyond [0:0] level. If VCC > 4.0V and startup current > 30 mA, it will be necessary to increment the BOOST[1:0] bits until the DC/DC converter is ready.

Incrementation of BOOST[1:0] bits increases at the same time the current overflow level in the same proportion as the startup current. So once the DC/DC converter is ready it is

advised to decrement the BOOST[1:0] bits to restore the overflow current to its normal or desired value.

Monitoring Procedure

Once the DC/DC has been successfully initialized, it is necessary to monitor the DC/DC converter by means of bits VCARDOK and ICARDOVF in the SCISR register.

Table 60. DC/DC converter status

VCARDOK	ICARDOVF	DC/DC Status
0	0	- Not Started or switched off by application. The current overflow sensor is disabled during the DC/DC converter startup. Then if a current overflow condition is applied during the DC/DC converter startup, the DC/DC converter is unable to start and both bits VCARDOK and ICARDOVF remains at 0.
		DC/DC converter correctly started then the output voltage is out of ISO/IEC 7816-3 specifications. In this case the firmware must take appropriate actions like deactivating the DC/DC converter in compliance with ISO/IEC 7816.
0	1	Started and automatically switched off by a current overflow condition
1	0	Operating properly according to ISO/IEC 7816-3 and EMV recommendations
1	1	Not applicable



DC/DC Converter register

Table 61. DC/DC Converter Control Register - DCCKPS (S:BFh)

7	6	5	4	3	2	1	0
MODE	OVFADJ	BOOST1	BOOST0	DCCKPS3	DCCKPS2	DCCKPS1	DCCKPS0
Bit Number	Bit Mnemonic	Description					
7	MODE	Regulation mode 0 : Pump mode (External Inductance required) 1 : Regulator mode (No External inductance required if VCC > CVCC+0.3V)					
6	OVFADJ	Current Overflow Adjustment on Smart Card terminal 0 : normal: 100 mA average 1 : normal + 20%					
5 - 4	BOOST[1:0]	VCARDOK=0			VCARDOK=1		
		Maximum Startup Current drawn from power supply 00 : Normal: 30 mA average 01 : Normal + 30% 10 : Normal + 50% 11 : Normal + 80%			Current Overflow Level on Smart Card terminal 00 : Normal = OVFADJ 01 : Normal + 30% 10 : Normal + 50% 11 : Normal + 80%		
3 - 0	DCCKPS[3:0]	DC/DC Clock Prescaler Value 0000 : Division factor: 2 (reset value) 0001 : Division factor: 3 0010 : Division factor: 4 0011 : Division factor: 5 0100 : Division factor: 6 0101 : Division factor: 8 0110 : Division factor: 10 0111 : Division factor: 12 1000 : Division factor: 24 Other values are reserved					

Reset Value = 0000 0000b

USB Controller

The AT8xC5122D implements a USB device controller supporting Full Speed data transfer. In addition to the default control endpoint 0, it provides 6 other endpoints, which can be configured in Control, Bulk, Interrupt or Isochronous modes:

- Endpoint 0: 32-byte FIFO, default control endpoint
- Endpoint 1,2,3: 8-byte FIFO
- Endpoint 4,5: 64-byte FIFO
- Endpoint 6: 2 x 64-byte Ping-pong FIFO

This allows the firmware to be developed conforming to most USB device classes, for example:

- USB Mass Storage Class Control/Bulk/Interrupt (CBI) Transport, Revision 1.0 - December 14, 1998.
- USB Mass Storage Class Bulk-Only Transport, Revision 1.0 - September 31, 1999.
- USB Human Interface Device Class, Version 1.1 - April 7, 1999.
- USB Device Firmware Upgrade Class, Revision 1.0 - May 13, 1999.

USB Mass Storage Classes

USB Mass Storage Class CBI Transport

Within the CBI framework, the Control endpoint is used to transport command blocks as well as to transport standard USB requests. One Bulk-Out endpoint is used to transport data from the host to the device. One Bulk-In endpoint is used to transport data from the device to the host. And one interrupt endpoint may also be used to signal command completion (protocol 0); it is optional and may not be used (protocol 1).

The following configuration adheres to these requirements:

- Endpoint 0: 8 bytes, Control In-Out
- Endpoint 4: 64 bytes, Bulk-Out
- Endpoint 5: 64 bytes, Bulk-In
- Endpoint 1: 8 bytes, Interrupt In

USB Mass Storage Class Bulk-Only Transport

Within the Bulk-Only framework, the Control endpoint is only used to transport class-specific and standard USB requests for device set-up and configuration. One Bulk-Out endpoint is used to transport commands and data from the host to the device. One Bulk-In endpoint is used to transport status and data from the device to the host. No interrupt endpoint is needed.

The following configuration adheres to these requirements:

- Endpoint 0: 8 bytes, Control In-Out
- Endpoint 4: 64 bytes, Bulk-Out
- Endpoint 5: 64 bytes, Bulk-In

USB Device Firmware Upgrade (DFU)

The USB Device Firmware Update (DFU) protocol can be used to upgrade the on-chip program memory of the AT8xC5122D. This allows the implementation of product enhancements and patches to devices that are already in the field. Two different configurations and description sets are used to support DFU functions. The Run-Time configuration co-exists with the usual functions of the device, which may be USB Mass Storage for the AT8xC5122D. It is used to initiate DFU from the normal operating mode. The DFU configuration is used to perform the firmware update after device re-configuration and USB reset. It excludes any other function. Only the default control pipe (endpoint 0) is used to support DFU services in both configurations.

The only possible value for the wMaxPacketSize in the DFU configuration is 32 bytes, which is the size of the FIFO implemented for endpoint 0.

Description

The USB device controller provides the hardware that the AT8xC5122D and the AT83C5123 need to interface a USB link to a data flow stored in a double port memory (DPRAM).

The USB controller requires a 48 MHz reference clock, which is the output of the AT8xC5122D/23 PLL (see Section "Phase Lock Loop (PLL)", page 40) divided by a clock prescaler. This clock is used to generate a 12 MHz full speed bit clock from the received USB differential data and to transmit data according to full speed USB device tolerance. Clock recovery is done by a Digital Phase Locked Loop (DPLL) block, which is compliant with the jitter specification of the USB bus.

The Interface Engine (SIE) block performs NRZI encoding and decoding, bit stuffing, CRC generation and checking, and the serial-parallel data conversion. The Universal Function Interface (UFI) performs the interface between the data flow and the Dual Port Ram

Figure 48. USB Device Controller Block Diagram

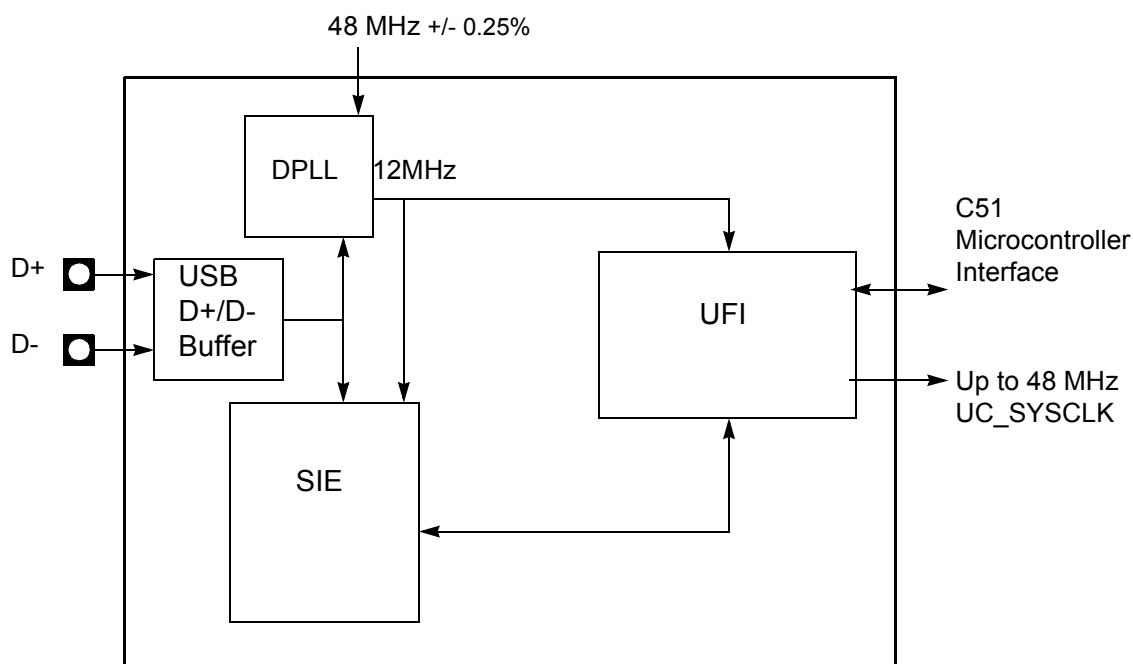

Serial Interface Engine (SIE)

The SIE performs the following functions:

- NRZI data encoding and decoding.
- Bit stuffing and unstuffing.
- CRC generation and checking.
- Handshakes.
- TOKEN type identifying.
- Address checking.
- Clock generation (via DPLL).

Figure 49. SIE Block Diagram

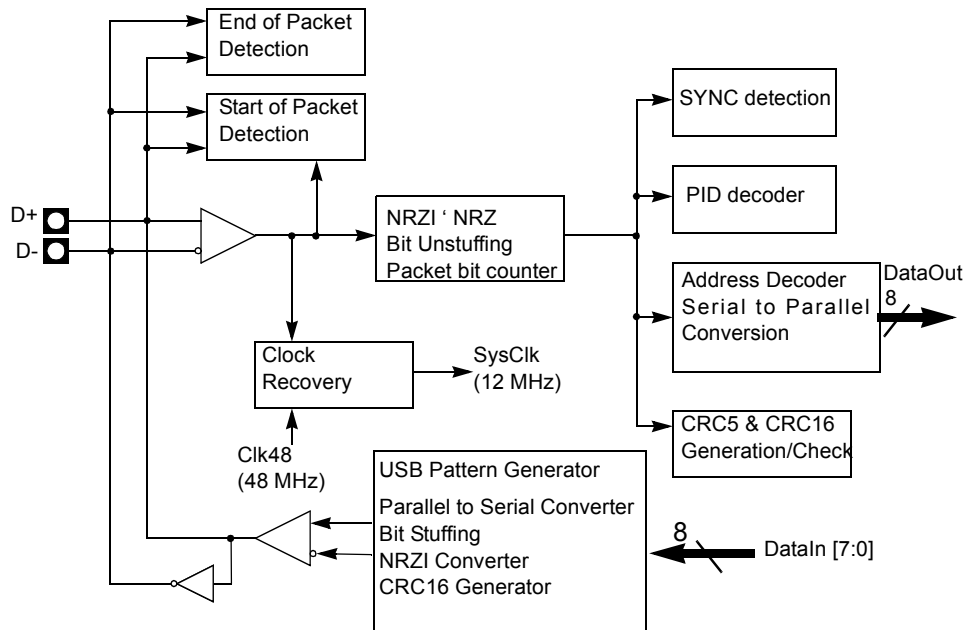

Function Interface Unit (UFI)

The Function Interface Unit provides the interface between the AT8xC5122D (or AT83C5123) and the SIE. It manages transactions at the packet level with minimal intervention from the device firmware, which reads and writes the endpoint FIFOs.

Figure 50. UFI Block Diagram

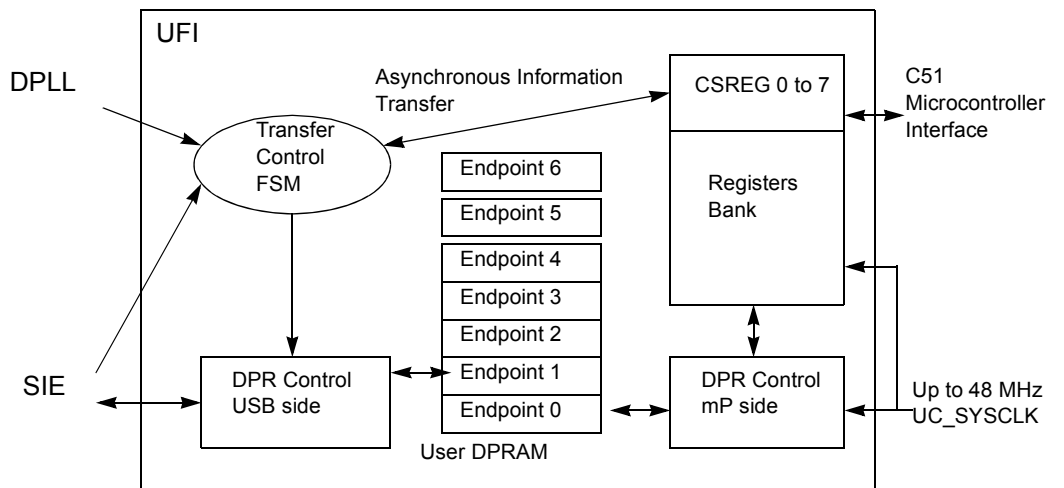
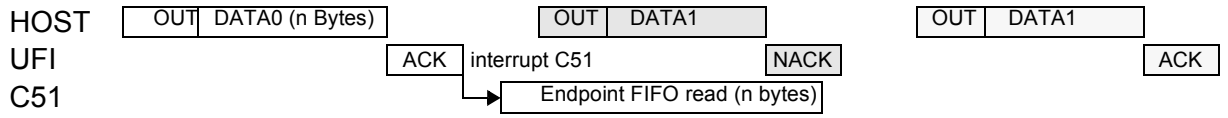
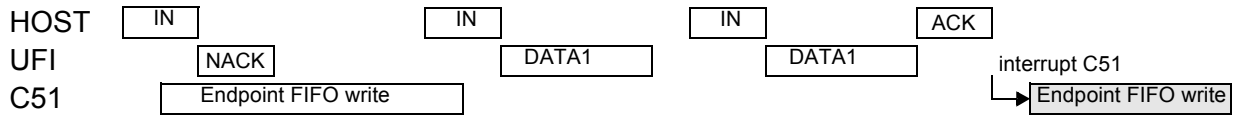

Figure 51. Minimum Intervention from the USB Device Firmware

OUT Transactions:



IN Transactions:



Configuration

General Configuration

- USB controller enable

Before any USB transaction, the 48 MHz required by the USB controller must be correctly generated (Section "Clock Controller", page 39).

The USB controller should be then enabled by setting the USBE bit in the USBCON register.

- Set address

After a Reset or a USB reset, the software has to set the FEN (Function Enable) bit in the USBADDR register. This action will allow the USB controller to answer to the requests sent at the address 0.

When a SET_ADDRESS request has been received, the USB controller must only answer to the address defined by the request. The new address should be stored in the USBADDR register. The FEN bit and the FADDEN bit in the USBCON register should be set to allow the USB controller to answer only to requests sent at the new address.

- Set configuration

The CONFIG bit in the USBCON register should be set after a SET_CONFIGURATION request with a non-zero value. Otherwise, this bit should be cleared.

Endpoint Configuration

- Selection of an Endpoint

The endpoint register access is performed using the UEPNUM register. The following registers

correspond to the endpoint whose number is stored in the UEPNUM register. To select an Endpoint, the firmware has to write the endpoint number in the UEPNUM register.

- UEPSTAX,
- UEPCONX,
- UEPCONX,
- UEPDATX,
- UBYCTX,

Figure 52. Endpoint Selection

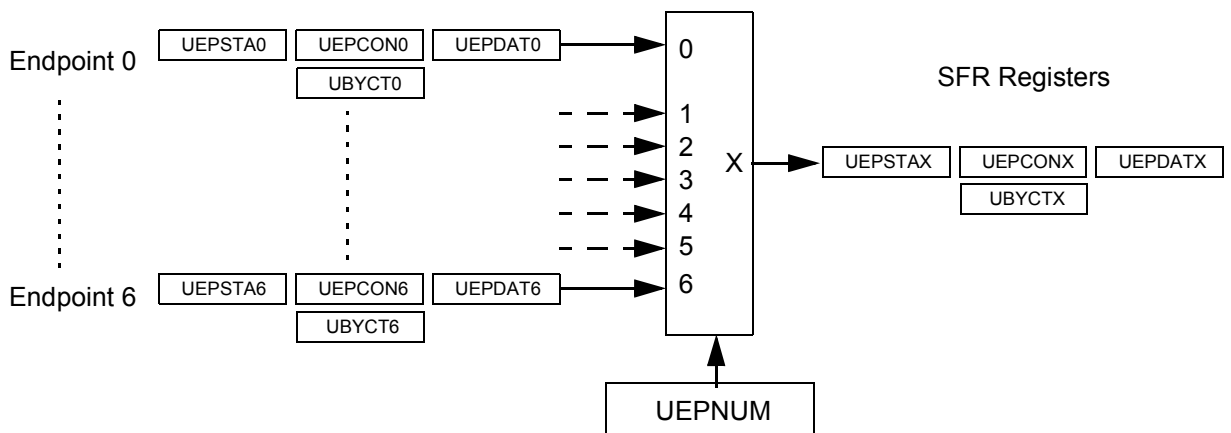



- Endpoint enable

Before using an endpoint, this one should be enabled by setting the EPEN bit in the UEPCONX register.

An endpoint which is not enabled won't answer to any USB request. The Default Control Endpoint (Endpoint 0) should always be enabled in order to answer to USB standard requests.

- Endpoint type configuration

All Standard Endpoints can be configured in Control, Bulk, Interrupt or Isochronous mode. The Ping-pong Endpoints can be configured in Bulk, Interrupt or Isochronous mode. The configuration of an endpoint is performed by setting the field EPTYPE with the following values:

- Control: EPTYPE = 00b
- Isochronous: EPTYPE = 01b
- Bulk: EPTYPE = 10b
- Interrupt: EPTYPE = 11b

The Endpoint 0 is the Default Control Endpoint and should always be configured in Control type.

- Endpoint direction configuration

For Bulk, Interrupt and Isochronous endpoints, the direction is defined with the EPDIR bit of the UEPCONX register with the following values:

- IN:EPDIR = 1b
- OUT:EPDIR = 0b

For Control endpoints, the EPDIR bit has no effect.

- Summary of Endpoint Configuration:

Make sure to select the correct endpoint number in the UEPNUM register before accessing to endpoint specific registers.

Table 62. Summary of Endpoint Configuration

Endpoint configuration	EPEN	EPDIR	EPTYPE	UEPCONX
Disabled	0b	Xb	XXb	0XXX XXXb
Control	1b	Xb	00b	80h
Bulk-In	1b	1b	10b	86h
Bulk-Out	1b	0b	10b	82h
Interrupt-In	1b	1b	11b	87h
Interrupt-Out	1b	0b	11b	83h
Isochronous-In	1b	1b	01b	85h
Isochronous-Out	1b	0b	01b	81h

- Endpoint FIFO reset

Before using an endpoint, its FIFO should be reset. This action resets the FIFO pointer to its original value, resets the byte counter of the endpoint (UBYCTX register), and resets the data toggle bit (DTGL bit in UEPCONX).

The reset of an endpoint FIFO is performed by setting to 1 and resetting to 0 the corresponding bit in the UEPRST register.

For example, in order to reset the Endpoint number 2 FIFO, write 0000 0100b then 0000 0000b in the UEPRST register.



Read/Write Data FIFO

Read Data FIFO

The read access for each OUT endpoint is performed using the UEPDATX register.

After a new valid packet has been received on an Endpoint, the data are stored into the FIFO and the byte counter of the endpoint is updated (UBYCTX register). The firmware has to store the endpoint byte counter before any access to the endpoint FIFO. The byte counter is not updated when reading the FIFO.

To read data from an endpoint, select the correct endpoint number in UEPNUM and read the UEPDATX register. This action automatically decreases the corresponding address vector, and the next data is then available in the UEPDATX register.

Write Data FIFO

The write access for each IN endpoint is performed using the UEPDATX register.

To write a byte into an IN endpoint FIFO, select the correct endpoint number in UEPNUM and write into the UEPDATX register. The corresponding address vector is automatically increased, and another write can be carried out.

Warning 1: The byte counter is not updated.

Warning 2: Do not write more bytes than supported by the corresponding endpoint.

Figure 53. Endpoint FIFO Configuration

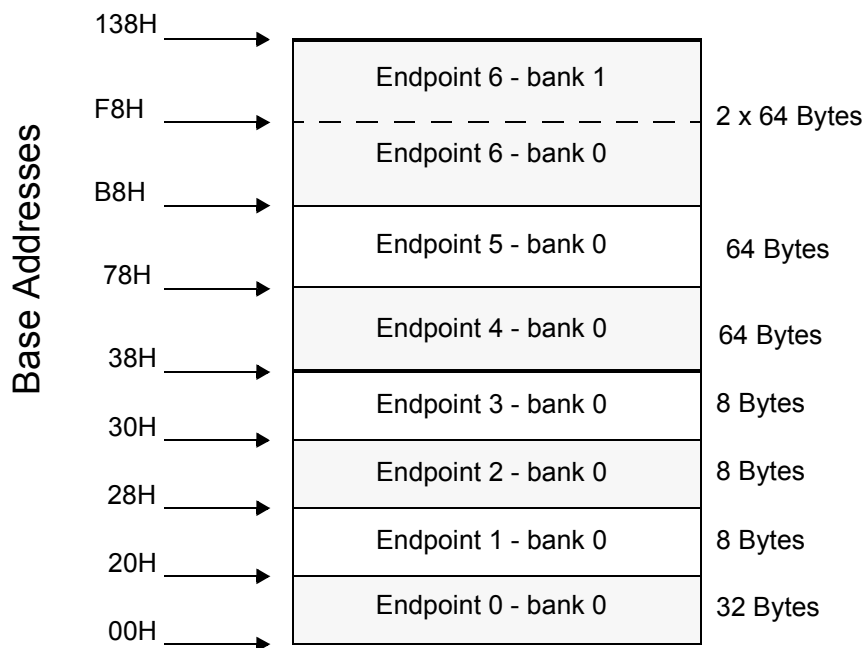

Bulk / Interrupt Transactions

Bulk and Interrupt transactions are managed in the same way.

Bulk/Interrupt OUT Transactions in Standard Mode

Figure 54. Bulk/Interrupt OUT transactions in Standard Mode

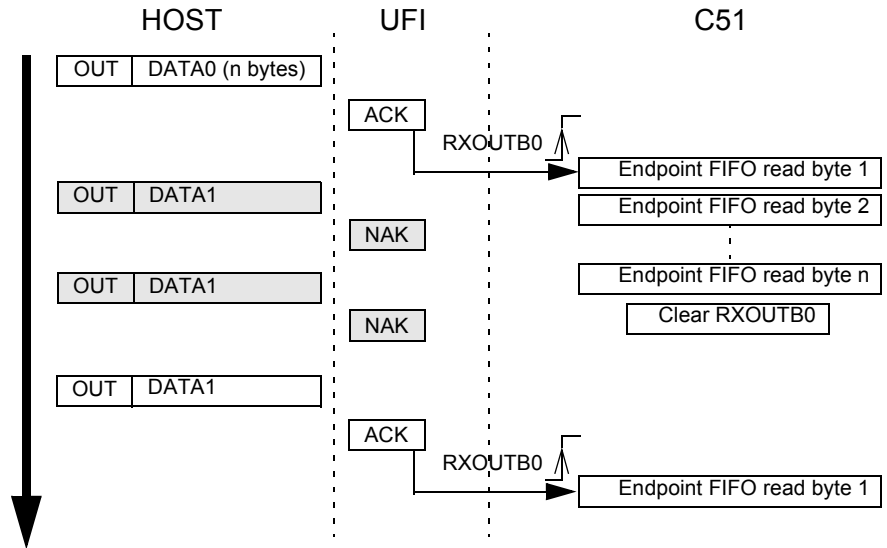

An endpoint should be first enabled and configured before being able to receive Bulk or Interrupt packets.

When a valid OUT packet is received on an endpoint, the RXOUTB0 bit is set by the USB controller. This triggers an interrupt if enabled. The firmware has to select the corresponding endpoint, store the number of data bytes by reading the UBYCTX register. If the received packet is a ZLP (Zero Length Packet), the UBYCTX register value is equal to 0 and no data has to be read.

When all the endpoint FIFO bytes have been read, the firmware should clear the RXOUTB0 bit to allow the USB controller to accept the next OUT packet on this endpoint. Until the RXOUTB0 bit has been cleared by the firmware, the USB controller will answer a NAK handshake for each OUT requests.

If the Host sends more bytes than supported by the endpoint FIFO, the overflow data won't be stored, but the USB controller will consider that the packet is valid if the CRC is correct and the endpoint byte counter contains the number of bytes sent by the Host.

Bulk/Interrupt OUT Transactions in Ping-Pong Mode (Endpoints 6)

Figure 55. Bulk / Interrupt OUT Transactions in Ping-Pong Mode

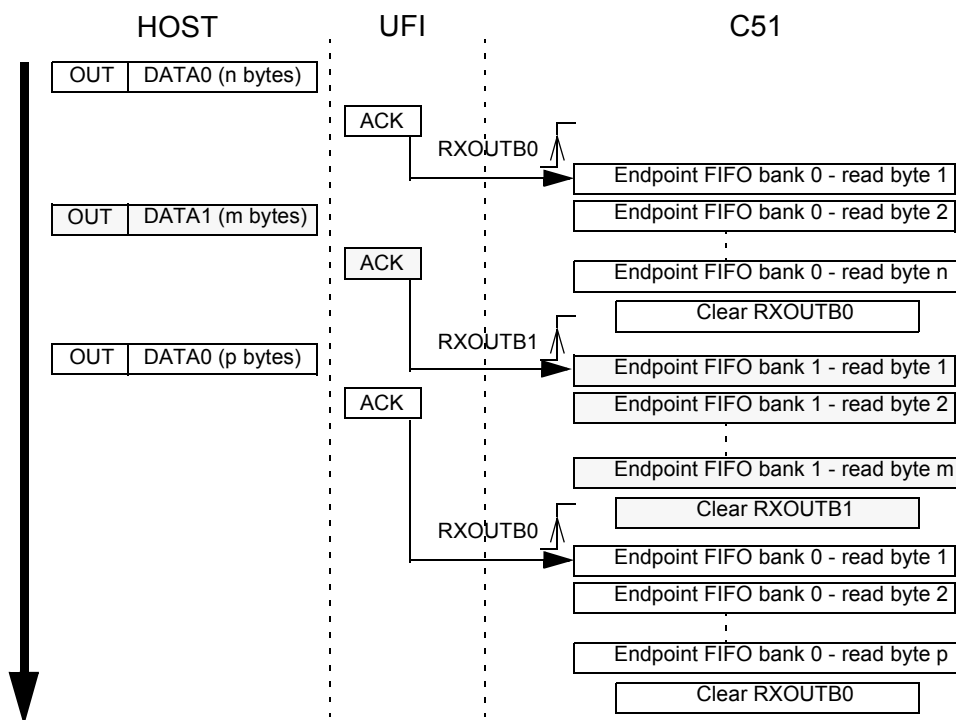

An endpoint should be first enabled and configured before being able to receive Bulk or Interrupt packets.

When a valid OUT packet is received on the endpoint bank 0, the RXOUTB0 bit is set by the USB controller. This triggers an interrupt if enabled. The firmware has to select the corresponding endpoint, store the number of data bytes by reading the UBYCTX register. If the received packet is a ZLP (Zero Length Packet), the UBYCTX register value is equal to 0 and no data has to be read.

When all the endpoint FIFO bytes have been read, the firmware should clear the RXOUB0 bit to allow the USB controller to accept the next OUT packet on the endpoint bank 0. This action switches the endpoint bank 0 and 1. Until the RXOUTB0 bit has been cleared by the firmware, the USB controller will answer a NAK handshake for each OUT requests on the bank 0 endpoint FIFO.

When a new valid OUT packet is received on the endpoint bank 1, the RXOUTB1 bit is set by the USB controller. This triggers an interrupt if enabled. The firmware empties the bank 1 endpoint FIFO before clearing the RXOUTB1 bit. Until the RXOUTB1 bit has been cleared by the firmware, the USB controller will answer a NAK handshake for each OUT requests on the bank 1 endpoint FIFO.

The RXOUTB0 and RXOUTB1 bits are alternatively set by the USB controller at each new valid packet receipt.

The firmware has to clear one of these two bits after having read all the data FIFO to allow a new valid packet to be stored in the corresponding bank.

A NAK handshake is sent by the USB controller only if the banks 0 and 1 has not been released by the firmware.

If the Host sends more bytes than supported by the endpoint FIFO, the overflow data won't be stored, but the USB controller will consider that the packet is valid if the CRC is correct.

Bulk/Interrupt IN Transactions In Standard Mode

Figure 56. Bulk/Interrupt IN Transactions in Standard Mode

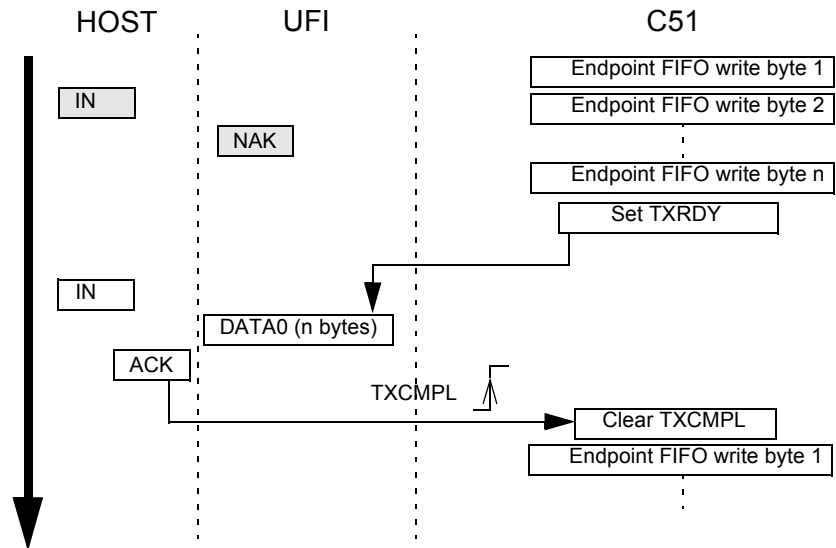

An endpoint should be first enabled and configured before being able to send Bulk or Interrupt packets.

The firmware should fill the FIFO with the data to be sent and set the TXRDY bit in the UEPSTAX register to allow the USB controller to send the data stored in FIFO at the next IN request concerning this endpoint. To send a Zero Length Packet, the firmware should set the TXRDY bit without writing any data into the endpoint FIFO.

Until the TXRDY bit has been set by the firmware, the USB controller will answer a NAK handshake for each IN requests.

To cancel the sending of this packet, the firmware has to reset the TXRDY bit. The packet stored in the endpoint FIFO is then cleared and a new packet can be written and sent.

When the IN packet has been sent and acknowledged by the Host, the TXCMPL bit in the UEPSTAX register is set by the USB controller. This triggers a USB interrupt if enabled. The firmware should clear the TXCMPL bit before filling the endpoint FIFO with new data.

The firmware should never write more bytes than supported by the endpoint FIFO.

All USB retry mechanisms are automatically managed by the USB controller.

Bulk/Interrupt IN Transactions in Ping-Pong Mode

Figure 57. Bulk / Interrupt IN transactions in Ping-Pong mode

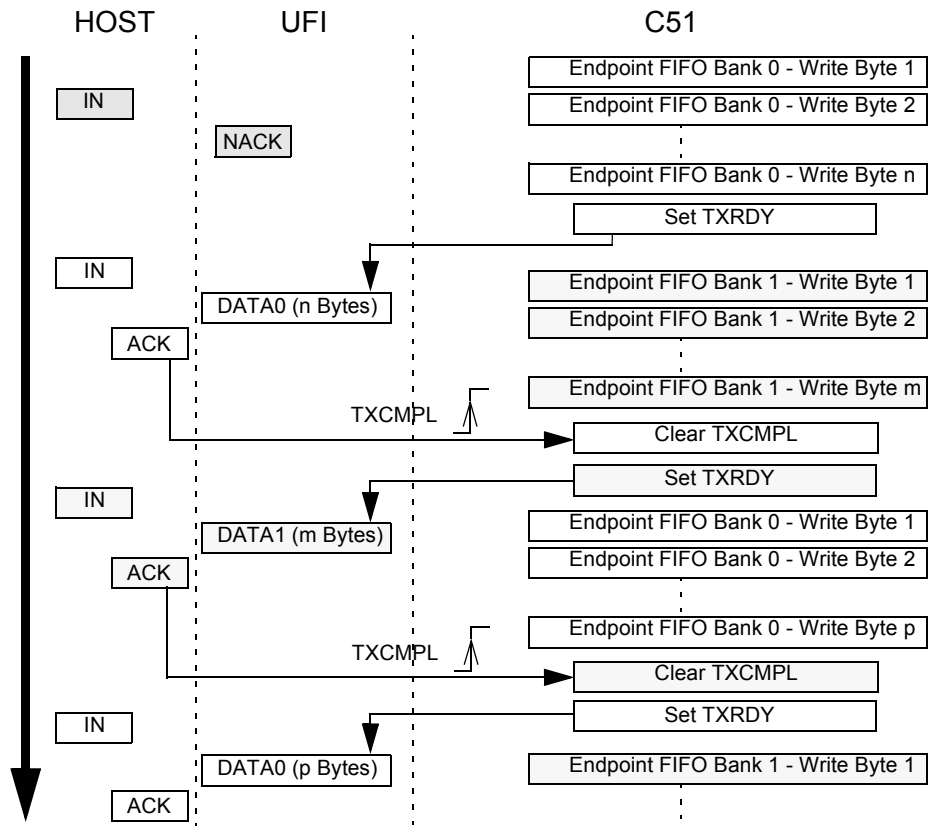

An endpoint will be first enabled and configured before being able to send Bulk or Interrupt packets.

The firmware will fill the FIFO bank 0 with the data to be sent and set the TXRDY bit in the UEPSTAX register to allow the USB controller to send the data stored in FIFO at the next IN request concerning the endpoint. The FIFO banks are automatically switched, and the firmware can immediately write into the endpoint FIFO bank 1.

When the IN packet concerning the bank 0 has been sent and acknowledged by the Host, the TXCMPL bit is set by the USB controller. This triggers a USB interrupt if enabled. The firmware will clear the TXCMPL bit before filling the endpoint FIFO bank 0 with new data. The FIFO banks are then automatically switched.

When the IN packet concerning the bank 1 has been sent and acknowledged by the Host, the TXCMPL bit is set by the USB controller. This triggers a USB interrupt if enabled. The firmware will clear the TXCMPL bit before filling the endpoint FIFO bank 1 with new data.

The bank switch is performed by the USB controller each time the TXRDY bit is set by the firmware. Until the TXRDY bit has been set by the firmware for an endpoint bank, the USB controller will answer a NAK handshake for each IN requests concerning this bank.

Note that in the example above, the firmware clears the Transmit Complete bit (TXCMPL) before setting the Transmit Ready bit (TXRDY). This is done in order to avoid the firmware to clear at the same time the TXCMPL bit for bank 0 and the bank 1.

The firmware will never write more bytes than supported by the endpoint FIFO.

Control Transactions

Setup Stage

The DIR bit in the UEPSTAX register should be at 0.

Receiving Setup packets is the same as receiving Bulk Out packets, except that the Rxsetup bit in the UEPSTAX register is set by the USB controller instead of the RXOUTB0 bit to indicate that an Out packet with a Setup PID has been received on the Control endpoint. When the RXSETUP bit has been set, all the other bits of the UEPSTAX register are cleared and an interrupt is triggered if enabled.

The firmware has to read the Setup request stored in the Control endpoint FIFO before clearing the RXSETUP bit to free the endpoint FIFO for the next transaction.

Data Stage: Control Endpoint Direction

The data stage management is similar to Bulk management.

A Control endpoint is managed by the USB controller as a full-duplex endpoint: IN and OUT. All other endpoint types are managed as half-duplex endpoint: IN or OUT. The firmware has to specify the control endpoint direction for the data stage using the DIR bit in the UEPSTAX register.

- If the data stage consists of INs, the firmware has to set the DIR bit in the UEPSTAX register before writing into the FIFO and sending the data by setting to 1 the TXRDY bit in the UEPSTAX register. The IN transaction is complete when the TXCMPL has been set by the hardware. The firmware should clear the TXCMPL bit before any other transaction.
- If the data stage consists of OUTs, the firmware has to leave the DIR bit at 0. The RXOUTB0 bit is set by hardware when a new valid packet has been received on the endpoint. The firmware must read the data stored into the FIFO and then clear the RXOUTB0 bit to reset the FIFO and to allow the next transaction.

The bit DIR is used to send the correct data toggle in the data stage.

To send a STALL handshake, see “STALL Handshake” on page 108.

Status Stage

The DIR bit in the UEPSTAX register should be reset at 0 for IN and OUT status stage.

The status stage management is similar to Bulk management.

- For a Control Write transaction or a No-Data Control transaction, the status stage consists of a IN Zero Length Packet (see “Bulk/Interrupt IN Transactions In Standard Mode” on page 103). To send a STALL handshake, see “STALL Handshake” on page 108.
- For a Control Read transaction, the status stage consists of a OUT Zero Length Packet (see “Bulk/Interrupt OUT Transactions in Standard Mode” on page 101).



Isochronous Transactions

Isochronous OUT Transactions in Standard Mode

An endpoint should be first enabled and configured before being able to receive Isochronous packets.

When an OUT packet is received on an endpoint, the RXOUTB0 bit is set by the USB controller. This triggers an interrupt if enabled. The firmware has to select the corresponding endpoint, store the number of data bytes by reading the UBYCTX register. If the received packet is a ZLP (Zero Length Packet), the UBYCTX register value is equal to 0 and no data has to be read.

The STLCRC bit in the UEPSTAX register is set by the USB controller if the packet stored in FIFO has a corrupted CRC. This bit is updated after each new packet receipt.

When all the endpoint FIFO bytes have been read, the firmware should clear the RXOUTB0 bit to allow the USB controller to store the next OUT packet data into the endpoint FIFO. Until the RXOUTB0 bit has been cleared by the firmware, the data sent by the Host at each OUT transaction will be lost.

If the RXOUTB0 bit is cleared while the Host is sending data, the USB controller will store only the remaining bytes into the FIFO.

If the Host sends more bytes than supported by the endpoint FIFO, the overflow data won't be stored, but the USB controller will consider that the packet is valid if the CRC is correct.

Isochronous OUT Transactions in Ping-pong Mode

An endpoint should be first enabled and configured before being able to receive Isochronous packets.

When a OUT packet is received on the endpoint bank 0, the RXOUTB0 bit is set by the USB controller. This triggers an interrupt if enabled. The firmware has to select the corresponding endpoint, store the number of data bytes by reading the UBYCTX register. If the received packet is a ZLP (Zero Length Packet), the UBYCTX register value is equal to 0 and no data has to be read.

The STLCRC bit in the UEPSTAX register is set by the USB controller if the packet stored in FIFO has a corrupted CRC. This bit is updated after each new packet receipt.

When all the endpoint FIFO bytes have been read, the firmware should clear the RXOUB0 bit to allow the USB controller to store the next OUT packet data into the endpoint FIFO bank 0. This action switches the endpoint bank 0 and 1. Until the RXOUTB0 bit has been cleared by the firmware, the data sent by the Host on the bank 0 endpoint FIFO will be lost.

If the RXOUTB0 bit is cleared while the Host is sending data on the endpoint bank 0, the USB controller will store only the remaining bytes into the FIFO.

When a new OUT packet is received on the endpoint bank 1, the RXOUTB1 bit is set by the USB controller. This triggers an interrupt if enabled. The firmware empties the bank 1 endpoint FIFO before clearing the RXOUTB1 bit. Until the RXOUTB1 bit has been cleared by the firmware, the data sent by the Host on the bank 1 endpoint FIFO will be lost.

The RXOUTB0 and RXOUTB1 bits are alternatively set by the USB controller at each new packet receipt.

The firmware has to clear one of these two bits after having read all the data FIFO to allow a new packet to be stored in the corresponding bank.

If the Host sends more bytes than supported by the endpoint FIFO, the overflow data won't be stored, but the USB controller will consider that the packet is valid if the CRC is correct.

Isochronous IN Transactions in Standard Mode

An endpoint should be first enabled and configured before being able to send Isochronous packets.

The firmware should fill the FIFO with the data to be sent and set the TXRDY bit in the UEPSTAX register to allow the USB controller to send the data stored in FIFO at the next IN request concerning this endpoint.

If the TXRDY bit is not set when the IN request occurs, nothing will be sent by the USB controller.

When the IN packet has been sent, the TXCMPL bit in the UEPSTAX register is set by the USB controller. This triggers a USB interrupt if enabled. The firmware should clear the TXCMPL bit before filling the endpoint FIFO with new data. The firmware should never write more bytes than supported by the endpoint FIFO.

Isochronous IN Transactions in Ping-Pong Mode

An endpoint should be first enabled and configured before being able to send Isochronous packets.

The firmware should fill the FIFO bank 0 with the data to be sent and set the TXRDY bit in the UEPSTAX register to allow the USB controller to send the data stored in FIFO at the next IN request concerning the endpoint. The FIFO banks are automatically switched, and the firmware can immediately write into the endpoint FIFO bank 1.

If the TXRDY bit is not set when the IN request occurs, nothing will be sent by the USB controller.

When the IN packet concerning the bank 0 has been sent, the TXCMPL bit is set by the USB controller. This triggers a USB interrupt if enabled. The firmware should clear the TXCMPL bit before filling the endpoint FIFO bank 0 with new data. The FIFO banks are then automatically switched.

When the IN packet concerning the bank 1 has been sent, the TXCMPL bit is set by the USB controller. This triggers a USB interrupt if enabled. The firmware should clear the TXCMPL bit before filling the endpoint FIFO bank 1 with new data.

The bank switch is performed by the USB controller each time the TXRDY bit is set by the firmware. Until the TXRDY bit has been set by the firmware for an endpoint bank, the USB controller won't send anything at each IN requests concerning this bank.

The firmware should never write more bytes than supported by the endpoint FIFO.



Miscellaneous

USB Reset

The EORINT bit in the USBINT register is set by hardware when a End of Reset has been detected on the USB bus. This triggers a USB interrupt if enabled. The USB controller is still enabled, but all the USB registers are reset by hardware. The firmware should clear the EORINT bit to allow the next USB reset detection.

STALL Handshake

This function is only available for Control, Bulk, and Interrupt endpoints.

The firmware has to set the STALLRQ bit in the UEPSTAX register to send a STALL handshake at the next request of the Host on the endpoint selected with the UEPNUM register. The RXSETUP, TXRDY, TXCMPL, RXOUTB0 and RXOUTB1 bits must be first reset to 0. The bit STLCRC is set at 1 by the USB controller when a STALL has been sent. This triggers an interrupt if enabled.

The firmware should clear the STALLRQ and STLCRC bits after each STALL sent. The STALLRQ bit is cleared automatically by hardware when a valid SETUP PID is received on a CONTROL type endpoint.

Start of Frame Detection

The SOFINT bit in the USBINT register is set when the USB controller detects a Start Of Frame PID. This triggers an interrupt if enabled. The firmware should clear the SOFINT bit to allow the next Start of Frame detection.

Frame Number

When receiving a Start of Frame, the frame number is automatically stored in the UFNUML and UFNUMH registers. The CRCOK and CRCERR bits indicate if the CRC of the last Start Of Frame is valid (CRCOK set at 1) or corrupt (CRCERR set at 1). The UFNUML and UFNUMH registers are automatically updated when receiving a new Start of Frame.

Data Toggle Bit

The Data Toggle bit is set by hardware when a DATA 0 packet is received and accepted by the USB controller and cleared by hardware when a DATA 1 packet is received and accepted by the USB controller. This bit is reset when the firmware resets the endpoint FIFO using the UEPRST register.

For Control endpoints, each SETUP transaction starts with a DATA 0 and data toggling is then used as for Bulk endpoints until the end of the Data stage (for a control write transfer). The Status stage completes the data transfer with a DATA 1 (for a control read transfer).

For Isochronous endpoints, the device firmware should ignore the data-toggle.

NAK Handshakes

When a NAK handshake is sent by the USB controller to a IN or OUT request from the Host, the NAKIN or NAKOUT bit is set by hardware. This information can be used to determine the direction of the communication during a Control transfer. These bits are cleared by software.

Suspend/Resume Management

Suspend

The Suspend state can be detected by the USB controller if all the clocks are enabled and if the USB controller is enabled. The bit SPINT is set by hardware when an idle state is detected for more than 3 ms. This triggers a USB interrupt if enabled.

In order to reduce current consumption, the firmware can put the USB PAD in idle mode, stop the clocks and put the C51 in Idle or Power-down mode. The Resume detection is still active.

The USB PAD is put in idle mode when the firmware clear the SPINT bit. In order to avoid a new suspend detection 3ms later, the firmware has to disable the USB clock input using the SUSPCLK bit in the USBCON Register. The USB PAD automatically exits of idle mode when a wake-up event is detected.

The stop of the 48 MHz clock from the PLL should be done in the following order:

1. Disable of the 48 MHz clock input of the USB controller by setting to 1 the SUSPCLK bit in the USBCON register.
2. Disable the PLL by clearing the PLEN bit in the PLLCON register.

Resume

When the USB controller is in Suspend state, the Resume detection is active even if all the clocks are disabled and if the C51 is in Idle or Power-down mode. The WUPCPU bit is set by hardware when a non-idle state occurs on the USB bus. This triggers an interrupt if enabled. This interrupt wakes up the CPU from its Idle or Power-down state and the interrupt function is then executed. The firmware will first enable the 48 MHz generation and then reset to 0 the SUSPCLK bit in the USBCON register if needed.

The firmware has to clear the SPINT bit in the USBINT register before any other USB operation in order to wake up the USB controller from its Suspend mode.

The USB controller is then re-activated.

Figure 58. Example of a Suspend/Resume Management

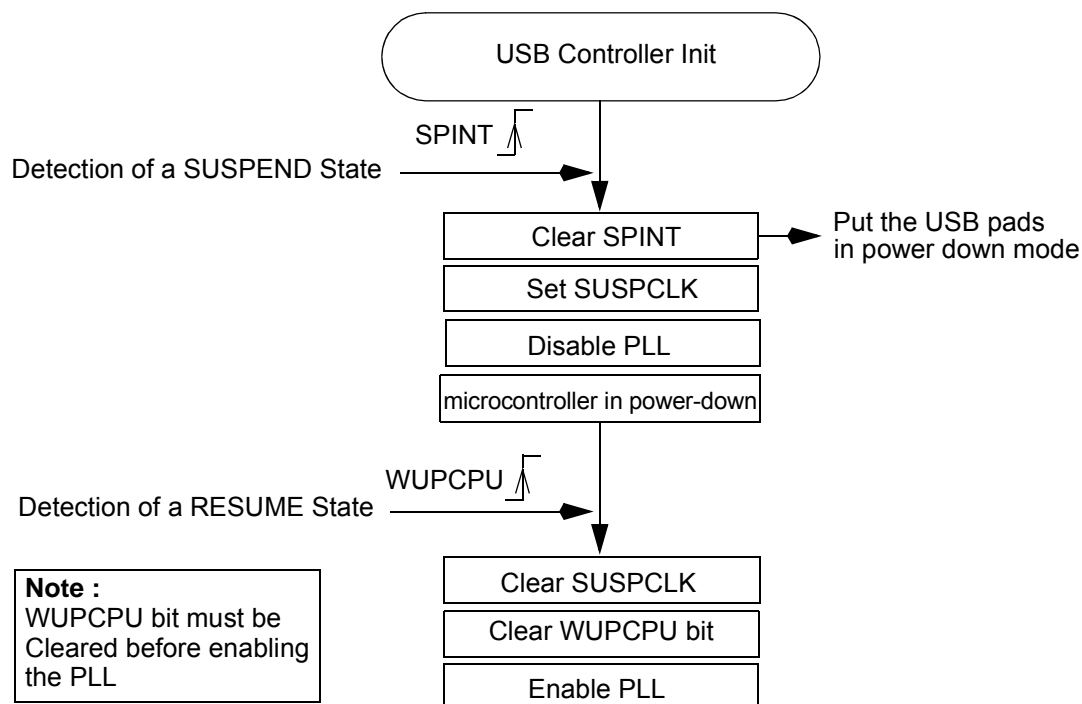

Warning: The core must be switched in external clock mode before disabling the PLL.

Upstream Resume

A USB device can be allowed by the Host to send an upstream resume for Remote Wake-up purpose.

When the USB controller receives the SET_FEATURE request: DEVICE_REMOTE_WAKEUP, the firmware should set to 1 the RMWUPE bit in the USBCON register to enable this function. RMWUPE value should be 0 in the other cases.

If the device is in SUSPEND mode, the USB controller can send an upstream resume by clearing first the SPINT bit in the USBINT register and by setting then to 1 the SDRMWUP bit in the USBCON register. The USB controller sets to 1 the UPRSM bit in the USBCON register. All clocks must be enabled first. The Remote Wake is sent only if the USB bus was in Suspend state for at least 5 ms. When the upstream resume is completed, the UPRSM bit is reset to 0 by hardware. The firmware should then clear the SDRMWUP bit.

Figure 59. Example of REMOTE WAKEUP Management

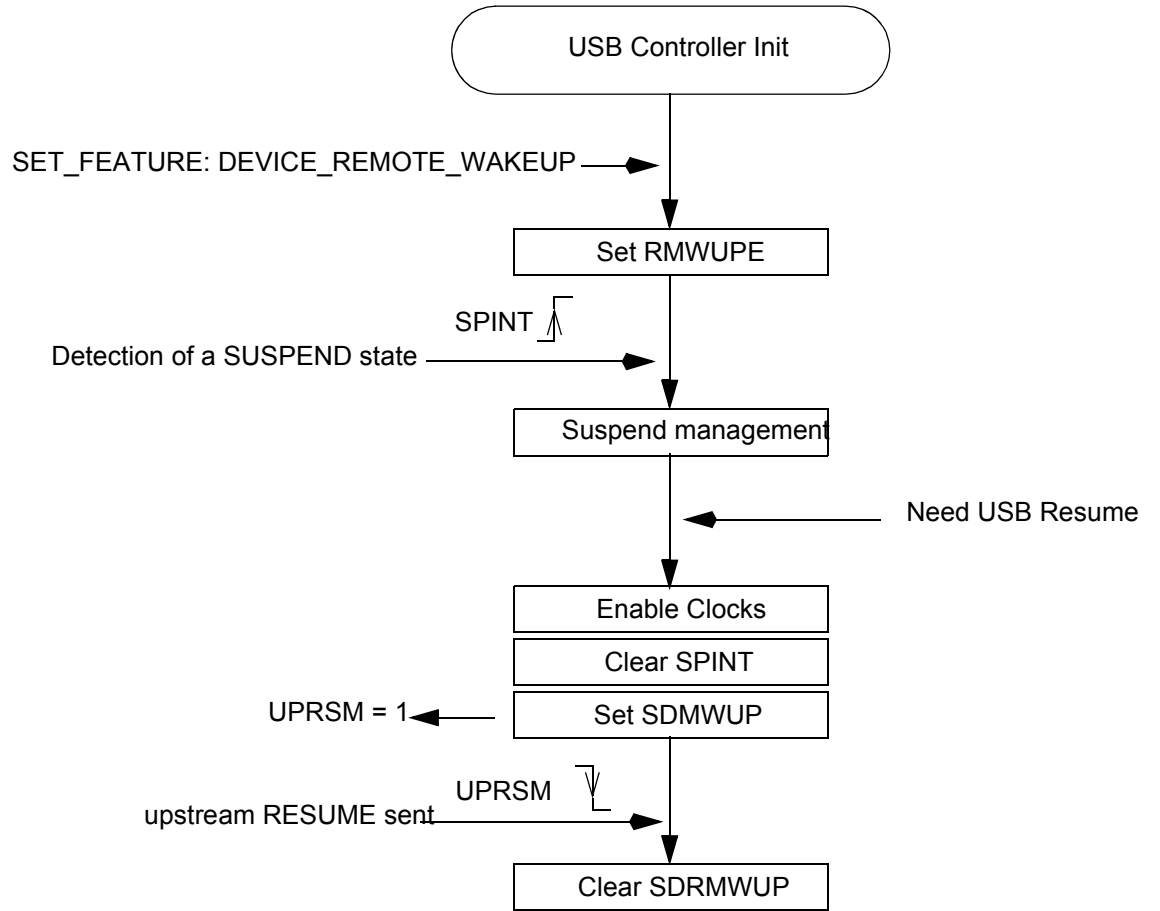

Detach Simulation

In order to be re-enumerated by the Host, the AT83R5122, AT8xC5122/23 has the possibility to simulate a DETACH-ATTACH of the USB bus.

The V_{REF} output voltage is between 3.0V and 3.6V. This output can be connected to the D+ pull-up as shown in Figure 60. This output can be put in high-impedance when the DETACH bit is set to 1 in the USBCON register. Maintaining this output in high impedance for more than 3 μ s will simulate the disconnection of the device. When resetting the DETACH bit, an ATTACH is then simulated. The USB controller should be enabled to use this feature.

Figure 60. Example of V_{REF} Connection

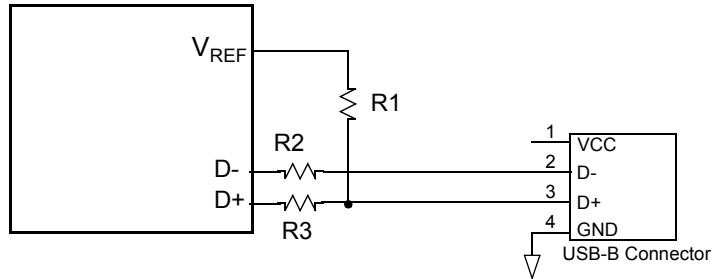
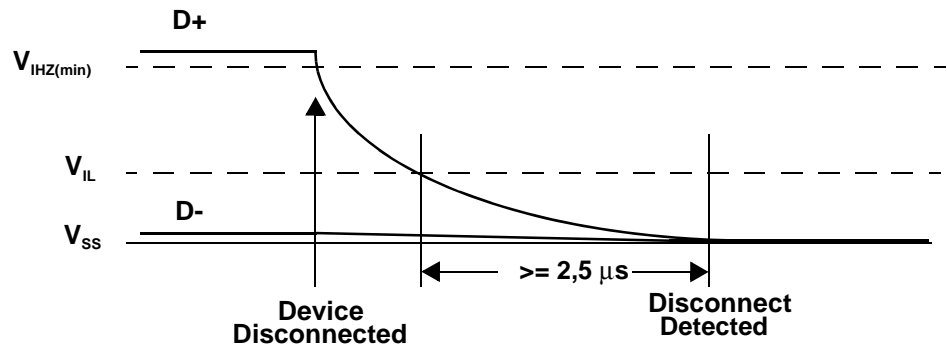

Figure 61. Disconnect Timing



USB Interrupt System

Interrupt System Priorities

Figure 62. USB Interrupt Control System

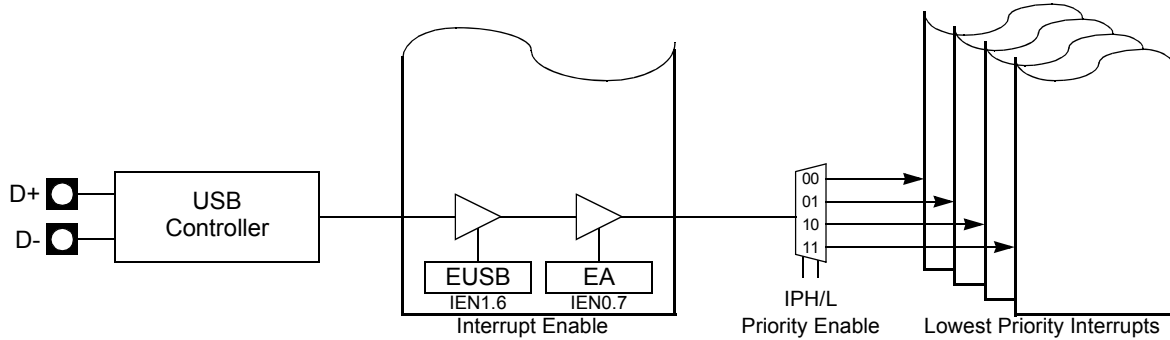

Table 63. Priority Levels

IPHUSB	IPLUSB	USB Priority Level
0	0	0 Lowest
0	1	1
1	0	2
1	1	3 Highest

Interrupt Control System

As shown in Figure 63, many events can produce a USB interrupt:

- TXCMPL: Transmitted In Data (Table 70 on page 119). This bit is set by hardware when the Host accept a In packet.
- RXOUTB0: Received Out Data Bank 0 (Table 70 on page 119). This bit is set by hardware when an Out packet is accepted by the endpoint and stored in bank 0.
- RXOUTB1: Received Out Data Bank 1 (only for Ping-Pong endpoints) (Table 70 on page 119). This bit is set by hardware when an Out packet is accepted by the endpoint and stored in bank 1.
- RXSETUP: Received Setup (Table 70 on page 119). This bit is set by hardware when an SETUP packet is accepted by the endpoint.
- NAKIN and NAKOUT: These bits are set by hardware when a Nak Handshake has been received on the corresponding endpoint. These bits are cleared by software.
- STLCRC: STALLED (only for Control, Bulk and Interrupt endpoints) (Table on page 120). This bit is set by hardware when a STALL handshake has been sent as requested by STALLRQ, and is reset by hardware when a SETUP packet is received.
- SOFINT: Start Of Frame Interrupt (Table 65 on page 116). This bit is set by hardware when a USB start of frame packet has been received.
- WUPCPU: Wake-Up CPU Interrupt (Table 65 on page 116). This bit is set by hardware when a USB resume is detected on the USB bus, after a SUSPEND state.
- SPINT: Suspend Interrupt (Table 65 on page 116). This bit is set by hardware when a USB suspend is detected on the USB bus.

Figure 63. USB Interrupt Control Block Diagram

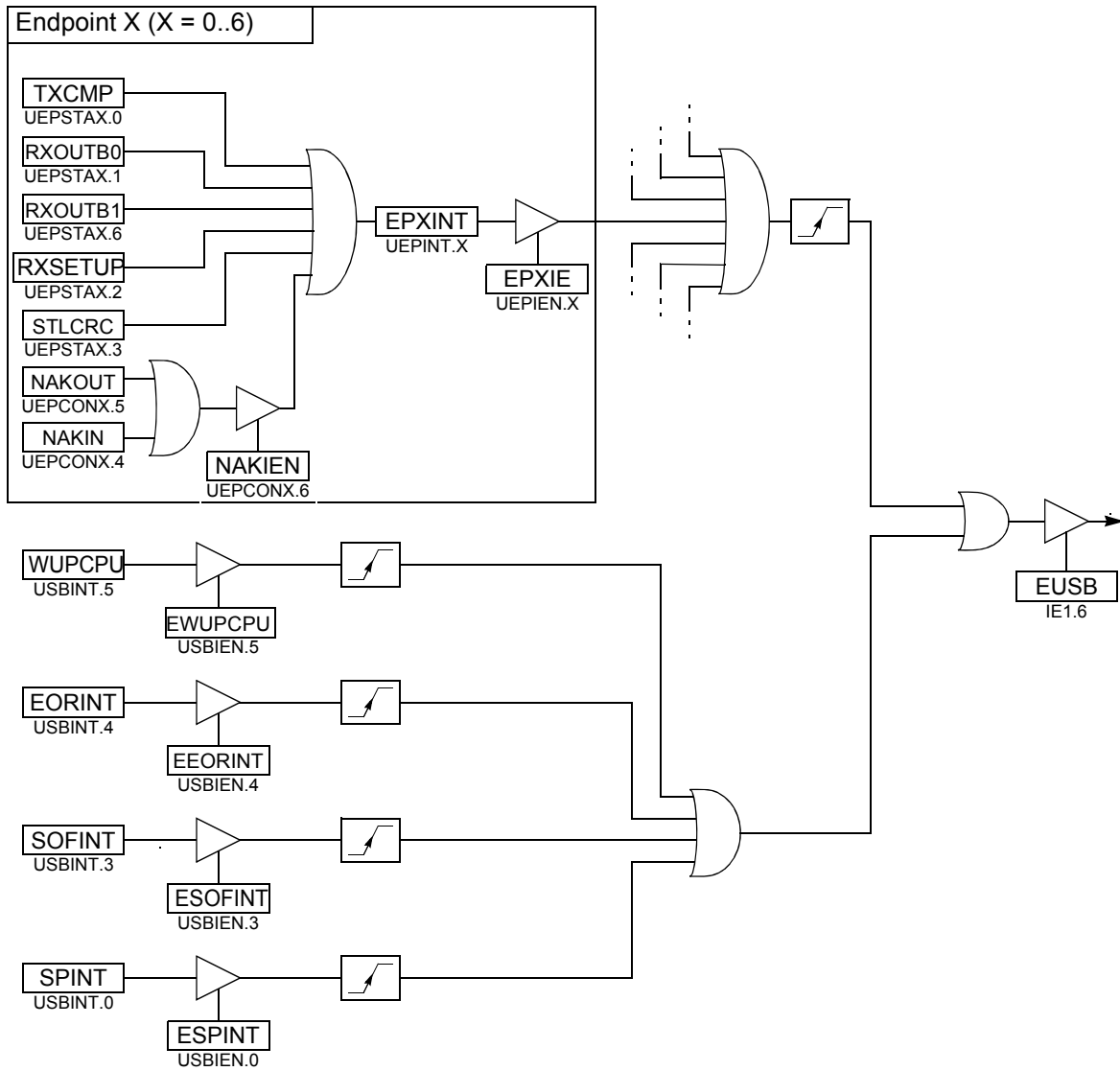

Registers

Table 64. USB Global Control Register - USBCON (S:BCh)

7	6	5	4	3	2	1	0
USBE	SUSPCLK	SDRMWUP	DETACH	UPRSM	RMWUPE	CONFG	FADDEN
Bit Number	Bit Mnemonic	Description					
7	USBE	USB Enable Set this bit to enable the USB controller. Clear this bit to disable and reset the USB controller, to disable the USB transceiver and to disable the USB controller clock inputs.					
6	SUSPCLK	Suspend USB Clock Set this bit to disable the 48MHz clock input (Resume Detection is still active). Clear this bit to enable the 48MHz clock input.					
5	SDRMWUP	Send Remote Wake-up Set this bit to force an external interrupt on the USB controller for Remote Wake UP purpose. An upstream resume is send only if the bit RMWUPE is set, all USB clocks are enabled AND the USB bus was in SUSPEND state for at least 5 ms. See UPRSM below. This bit is cleared by software.					
4	DETACH	Detach Command Set this bit to simulate a Detach on the USB line. The V_{REF} pin is then in a floating state. Clear this bit to maintain V_{REF} at 3.3V.					
3	UPRSM	Upstream Resume (read only) This bit is set by hardware when SDRMWUP has been set and if RMWUPE is enabled. This bit is cleared by hardware after the upstream resume has been sent.					
2	RMWUPE	Remote Wake-Up Enable Set this bit to enabled request an upstream resume signaling to the host. Clear this bit otherwise. Note: Do not set this bit if the host has not set the DEVICE_REMOTE_WAKEUP feature for the device.					
1	CONFG	Configured This bit should be set by the device firmware after a SET_CONFIGURATION request with a non-zero value has been correctly processed. It should be cleared by the device firmware when a SET_CONFIGURATION request with a zero value is received. It is cleared by hardware on hardware reset or when an USB reset is detected on the bus (SE0 state for at least 32 Full Speed bit times: typically 2.7 μ s).					
0	FADDEN	Function Address Enable This bit should be set by the device firmware after a successful status phase of a SET_ADDRESS transaction. It should not be cleared afterwards by the device firmware. It is cleared by hardware on hardware reset or when an USB reset is received (see above). When this bit is cleared, the default function address is used (0).					

Reset Value = 0000 0000b

Table 65. USB Global Interrupt Register - USBINT (S:BDh)

	7	6	5	4	3	2	1	0
	-	-	WUPCPU	EORINT	SOFINT	-	-	SPINT

Bit Number	Bit Mnemonic	Description
7 - 6	-	Reserved The value read from these bits is always 0. Do not change these bits.
5	WUPCPU	Wake-up CPU Interrupt This bit is set by hardware when the USB controller is in SUSPEND state and is re-activated by a non-idle signal FROM USB line (not by an upstream resume). This triggers a USB interrupt when EWUPCPU is set in the Table on page 117. When receiving this interrupt, user has to enable all USB clock inputs. This bit should be cleared by software (USB clocks must be enabled before).
4	EORINT	End of Reset Interrupt This bit is set by hardware when End of Reset has been detected by the USB controller. This triggers a USB interrupt when EEORINT is set in the Table on page 117. This bit should be cleared by software.
3	SOFINT	Start Of Frame Interrupt This bit is set by hardware when an USB Start Of Frame PID (SOF) has been detected. This triggers a USB interrupt when ESOFINT is set in the Table on page 117. This bit should be cleared by software.
2-1	-	Reserved The value read from these bits is always 0. Do not change these bits.
0	SPINT	Suspend Interrupt This bit is set by hardware when a USB Suspend (Idle bus for three frame periods: a J state for 3 ms) is detected. This triggers a USB interrupt when ESPINT is set in USBIEN register (Table 66 on page 117). This bit must be cleared by software before powering the microcontroller down as it disables the USB pads to reduce the power consumption.

Reset Value = 0000 0000b

Table 66. USB Global Interrupt Enable Register - USBIEN (S:BEh)

7	6	5	4	3	2	1	0
-	-	EWUPCPU	EEORINT	ESOFINT	-	-	ESPINT
Bit Number	Bit Mnemonic	Description					
7 - 6	-	Reserved The value read from these bits is always 0. Do not change these bits.					
5	EWUPCPU	Enable Wake-up CPU Interrupt Set this bit to enable Wake-up CPU Interrupt. Clear this bit to disable Wake-up CPU Interrupt.					
4	EEORINT	Enable End of Reset Interrupt Set this bit to enable End of Reset Interrupt. This bit is set after reset. Clear this bit to disable End of Reset Interrupt.					
3	ESOFINT	Enable SOF Interrupt Set this bit to enable SOF Interrupt. Clear this bit to disable SOF Interrupt.					
2-1	-	Reserved The value read from these bits is always 0. Do not change these bits.					
0	ESPINT	Enable Suspend Interrupt Set this bit to enable Suspend Interrupts (See Table 65 on page 116). Clear this bit to disable Suspend Interrupts.					

Reset Value = 0001 0000b

Table 67. USB Address Register - USBADDR (S:C6h)

7	6	5	4	3	2	1	0
FEN	UADD6	UADD5	UADD4	UADD3	UADD2	UADD1	UADD0
Bit Number	Bit Mnemonic	Description					
7	FEN	Function Enable Set this bit to enable the function. FADD is reset to 1. Cleared this bit to disable the function.					
6-0	UADD[6:0]	USB Address This field contains the default address (0) after power-up or USB bus reset. It should be written with the value set by a SET_ADDRESS request received by the device firmware.					

Reset Value = 1000 0000b





Table 68. USB Endpoint Number - UEPNUM (S:C7h)

7	6	5	4	3	2	1	0
-	-	-	-	EPNUM3	EPNUM2	EPNUM1	EPNUM0
Bit Number	Bit Mnemonic	Description					
7 - 4	-	Reserved The value read from these bits is always 0. Do not change these bits.					
3 - 0	EPNUM[3:0]	Endpoint Number Set this field with the number of the endpoint which should be accessed when reading or writing to, USB Byte Count Register X (X=EPNUM set in UEPNUM Register) - UBYCTX (S:E2h) or USB Endpoint X Control Register - UEPCONX (S:D4h). This value can be 0, 1, 2, 3, 4, 5 or 6.					

Reset Value = 0000 0000b

Table 69. USB Endpoint X Control Register - UEPCONX (S:D4h)

7	6	5	4	3	2	1	0
EPEN	NAKIEN	NAKOUT	NAKIN	DTGL	EPDIR	EPTYPE1	EPTYPE0
Bit Number	Bit Mnemonic	Description					
7	EPEN	Endpoint Enable Set this bit to enable the endpoint according to the device configuration. Endpoint 0 will always be enabled after a hardware or USB bus reset and participate in the device configuration. Clear this bit to disable the endpoint according to the device configuration.					
6	NAKIEN	NAK Interrupt Enable Set this bit to enable NAKIN and NAKOUT Interrupt. Clear this bit to disable NAKIN and NAKOUT Interrupt.					
5	NAKOUT	NAK OUT Sent This bit is set by hardware when the a NAK handshake is sent by the USB controller to an OUT request from the Host. This generates an interrupt if the NAKIEN bit is set. This bit shall be cleared by software.					
4	NAKIN	NAK IN Sent This bit is set by hardware when the a NAK handshake is sent by the USB controller to an IN request from the Host. This generates an interrupt if the NAKIEN bit is set. This bit shall be cleared by software.					
3	DTGL	Data Toggle (Read-only) This bit is set by hardware when a valid DATA0 packet is received and accepted. This bit is cleared by hardware when a valid DATA1 packet is received and accepted.					
2	EPDIR	Endpoint Direction Set this bit to configure IN direction for Bulk, Interrupt and Isochronous endpoints. Clear this bit to configure OUT direction for Bulk, Interrupt and Isochronous endpoints. This bit has no effect for Control endpoints.					
1-0	EPTYPE[1:0]	Endpoint Type Set this field according to the endpoint configuration (Endpoint 0 will always be configured as control): 00Control endpoint 01Isochronous endpoint 10Bulk endpoint 11Interrupt endpoint					

Reset Value = 1000 0000b when UEPNUM = 0

Reset Value = 0000 0000b otherwise

Table 70. USB Endpoint Status and Control Register X - UEPSTAX (S:CEh) X=EPNUM set in UEPNUM Register)

7	6	5	4	3	2	1	0
DIR	RXOUTB1	STALLRQ	TXRDY	STL/CRC	RXSETUP	RXOUTB0	TXCMP
Bit Number	Bit Mnemonic	Description					
7	DIR	<p>Control Endpoint Direction This bit is used only if the endpoint is configured in the control type (see “USB Endpoint X Control Register - UEPCONX (S:D4h)” on page 118). This bit determines the Control data and status direction. The device firmware should set this bit ONLY for the IN data stage, before any other USB operation. Otherwise, the device firmware should clear this bit.</p>					
6	RXOUTB1	<p>Received OUT Data Bank 1 for Endpoint 6 (Ping-pong Mode) This bit is set by hardware after a new packet has been stored in the endpoint FIFO Data bank 1 (only in Ping-pong mode). Then, the endpoint interrupt is triggered if enabled (see “USB Global Interrupt Register - USBINT (S:BDh)” on page 116) and all the following OUT packets to the endpoint bank 1 are rejected (NAK’ed) until this bit has been cleared, excepted for Isochronous Endpoints. This bit should be cleared by the device firmware after reading the OUT data from the endpoint FIFO.</p>					
5	STALLRQ	<p>Stall Handshake Request Set this bit to request a STALL answer to the host for the next handshake. Clear this bit otherwise. For CONTROL endpoints: cleared by hardware when a valid SETUP PID is received.</p>					
4	TXRDY	<p>TX Packet Ready Set this bit after a packet has been written into the endpoint FIFO for IN data transfers. Data should be written into the endpoint FIFO only after this bit has been cleared. Set this bit without writing data to the endpoint FIFO to send a Zero Length Packet. This bit is cleared by hardware, as soon as the packet has been sent for Isochronous endpoints, or after the host has acknowledged the packet for Control, Bulk and Interrupt endpoints. When this bit is cleared, the endpoint interrupt is triggered if enabled (see Table 65 on page 116).</p>					
3	STLCRC	<p>Stall Sent / CRC error flag - For Control, Bulk and Interrupt Endpoints: This bit is set by hardware after a STALL handshake has been sent as requested by STALLRQ. Then, the endpoint interrupt is triggered if enabled (see “” on page 116) It should be cleared by the device firmware. - For Isochronous Endpoints (Read-Only): This bit is set by hardware if the last received data is corrupted (CRC error on data). This bit is updated by hardware when a new data is received.</p>					
2	RXSETUP	<p>Received SETUP This bit is set by hardware when a valid SETUP packet has been received from the host. Then, all the other bits of the register are cleared by hardware and the endpoint interrupt is triggered if enabled (see Table 65 on page 116). It should be cleared by the device firmware after reading the SETUP data from the endpoint FIFO.</p>					
1	RXOUTB0	<p>Received OUT Data Bank 0 (see also RXOUTB1 bit for Ping-pong Endpoints) This bit is set by hardware after a new packet has been stored in the endpoint FIFO data bank 0. Then, the endpoint interrupt is triggered if enabled (see “” on page 116) and all the following OUT packets to the endpoint bank 0 are rejected (NAK’ed) until this bit has been cleared, excepted for Isochronous Endpoints. However, for control endpoints, an early SETUP transaction may overwrite the content of the endpoint FIFO, even if its Data packet is received while this bit is set. This bit should be cleared by the device firmware after reading the OUT data from the endpoint FIFO.</p>					
0	TXCMLP	<p>Transmitted IN Data Complete This bit is set by hardware after an IN packet has been transmitted for Isochronous endpoints and after it has been accepted (ACK’ed) by the host for Control, Bulk and Interrupt endpoints. Then, the endpoint interrupt is triggered if enabled (see Table 65). This bit should be cleared by the device firmware before setting TXRDY.</p>					

Reset Value = 0000 0000b



Table 71. USB FIFO Data Endpoint X (X=EPNUM set in UEPNUM Register) - UEPDATX (S:CFh)

7	6	5	4	3	2	1	0
FDAT7	FDAT6	FDAT5	FDAT4	FDAT3	FDAT2	FDAT1	FDAT0
Bit Number	Bit Mnemonic	Description					
7 - 0	FDAT[7:0]	Endpoint X FIFO data Data byte to be written to FIFO or data byte to be read from the FIFO, for the Endpoint X (see EPNUM).					

Reset Value = XXXX XXXXb

Table 72. USB Byte Count Register X (X=EPNUM set in UEPNUM Register) - UBYCTX (S:E2h)

7	6	5	4	3	2	1	0
-	BYCT6	BYCT5	BYCT4	BYCT3	BYCT2	BYCT1	BYCT0
Bit Number	Bit Mnemonic	Description					
7	-	Reserved The value read from these bits is always 0. Do not change this bit.					
6 - 0	BYCT[6:0]	Byte Count LSB Least Significant Byte of the byte count of a received data packet. This byte count is equal to the number of data bytes received after the Data PID.					

Reset Value = 0000 0000b

Table 73. USB Endpoint FIFO Reset Register - UEPRST (S:D5h)

7	6	5	4	3	2	1	0
-	EP6RST	EP5RST	EP4RST	EP3RST	EP2RST	EP1RST	EP0RST
Bit Number	Bit Mnemonic	Description					
7	-	Reserved The value read from these bits is always 0. Do not change this bit.					
6	EP6RST	Endpoint 6 FIFO Reset Set this bit and reset the endpoint FIFO prior to any other operation, upon hardware reset or when an USB bus reset has been received. Then, clear this bit to complete the reset operation and start using the FIFO.					
5	EP5RST	Endpoint 5 FIFO Reset Set this bit and reset the endpoint FIFO prior to any other operation, upon hardware reset or when an USB bus reset has been received. Then, clear this bit to complete the reset operation and start using the FIFO.					
4	EP4RST	Endpoint 4 FIFO Reset Set this bit and reset the endpoint FIFO prior to any other operation, upon hardware reset or when an USB bus reset has been received. Then, clear this bit to complete the reset operation and start using the FIFO.					
3	EP3RST	Endpoint 3 FIFO Reset Set this bit and reset the endpoint FIFO prior to any other operation, upon hardware reset or when an USB bus reset has been received. Then, clear this bit to complete the reset operation and start using the FIFO.					
2	EP2RST	Endpoint 2 FIFO Reset Set this bit and reset the endpoint FIFO prior to any other operation, upon hardware reset or when an USB bus reset has been received. Then, clear this bit to complete the reset operation and start using the FIFO.					
1	EP1RST	Endpoint 1 FIFO Reset Set this bit and reset the endpoint FIFO prior to any other operation, upon hardware reset or when an USB bus reset has been received. Then, clear this bit to complete the reset operation and start using the FIFO.					
0	EP0RST	Endpoint 0 FIFO Reset Set this bit and reset the endpoint FIFO prior to any other operation, upon hardware reset or when an USB bus reset has been received. Then, clear this bit to complete the reset operation and start using the FIFO.					

Reset Value = 0000 0000b

Table 74. USB Endpoint Interrupt Register - UEPINT (S:F8h read-only)

7	6	5	4	3	2	1	0
-	EP6INT	EP5INT	EP4INT	EP3INT	EP2INT	EP1INT	EP0INT
Bit Number	Bit Mnemonic	Description					
7	-	Reserved The value read from these bits is always 0. Do not change this bit.					
6	EP6INT	Endpoint 6 Interrupt This bit is set by hardware when an interrupt has been detected on the endpoint 6. The interrupt sources are part of UEPSTAX register and can be : TXCMP, RXOUTB0, RXOUTB1, RXSETUP or STLCRC. A USB interrupt is triggered when the EP6INTE bit in the UEPIEN register is set. This bit is cleared by hardware when all the interrupt sources are cleared.					
5	EP5INT	Endpoint 5 Interrupt This bit is set by hardware when an interrupt has been detected on the endpoint 5. The interrupt sources are part of UEPSTAX register and can be : TXCMP, RXOUTB0, RXOUTB1, RXSETUP or STLCRC. A USB interrupt is triggered when the EP5INTE bit in the UEPIEN register is set. This bit is cleared by hardware when all the interrupt sources are cleared.					
4	EP4INT	Endpoint 4 Interrupt This bit is set by hardware when an interrupt has been detected on the endpoint 4. The interrupt sources are part of UEPSTAX register and can be : TXCMP, RXOUTB0, RXOUTB1, RXSETUP or STLCRC. A USB interrupt is triggered when the EP4INTE bit in the UEPIEN register is set. This bit is cleared by hardware when all the interrupt sources are cleared.					
3	EP3INT	Endpoint 3 Interrupt This bit is set by hardware when an interrupt has been detected on the endpoint 3. The interrupt sources are part of UEPSTAX register and can be : TXCMP, RXOUTB0, RXOUTB1, RXSETUP or STLCRC. A USB interrupt is triggered when the EP3INTE bit in the UEPIEN register is set. This bit is cleared by hardware when all the interrupt sources are cleared.					
2	EP2INT	Endpoint 2 Interrupt This bit is set by hardware when an interrupt has been detected on the endpoint 2. The interrupt sources are part of UEPSTAX register and can be : TXCMP, RXOUTB0, RXOUTB1, RXSETUP or STLCRC. A USB interrupt is triggered when the EP2INTE bit in the UEPIEN register is set. This bit is cleared by hardware when all the interrupt sources are cleared.					
1	EP1INT	Endpoint 1 Interrupt This bit is set by hardware when an interrupt has been detected on the endpoint 1. The interrupt sources are part of UEPSTAX register and can be : TXCMP, RXOUTB0, RXOUTB1, RXSETUP or STLCRC. A USB interrupt is triggered when the EP1INTE bit in the UEPIEN register is set. This bit is cleared by hardware when all the interrupt sources are cleared.					
0	EP0INT	Endpoint 0 Interrupt This bit is set by hardware when an interrupt has been detected on the endpoint 0. The interrupt sources are part of UEPSTAX register and can be : TXCMP, RXOUTB0, RXOUTB1, RXSETUP or STLCRC. A USB interrupt is triggered when the EP0INTE bit in the UEPIEN register is set. This bit is cleared by hardware when all the interrupt sources are cleared.					

Reset Value = 0000 0000b

Table 75. USB Endpoint Interrupt Enable Register - UEPIEN (S:C2h)

7	6	5	4	3	2	1	0
-	EP6INTE	EP5INTE	EP4INTE	EP3INTE	EP2INTE	EP1INTE	EPOINTE
Bit Number	Bit Mnemonic	Description					
7	-	Reserved The value read from these bits is always 0. Do not change this bit.					
6	EP6INTE	Endpoint 6 Interrupt Enable Set this bit to enable the interrupts for this endpoint. Clear this bit to disable the interrupts for this endpoint.					
5	EP5INTE	Endpoint 5 Interrupt Enable Set this bit to enable the interrupts for this endpoint. Clear this bit to disable the interrupts for this endpoint.					
4	EP4INTE	Endpoint 4 Interrupt Enable Set this bit to enable the interrupts for this endpoint. Clear this bit to disable the interrupts for this endpoint.					
3	EP3INTE	Endpoint 3 Interrupt Enable Set this bit to enable the interrupts for this endpoint. Clear this bit to disable the interrupts for this endpoint.					
2	EP2INTE	Endpoint 2 Interrupt Enable Set this bit to enable the interrupts for this endpoint. Clear this bit to disable the interrupts for this endpoint.					
1	EP1INTE	Endpoint 1 Interrupt Enable Set this bit to enable the interrupts for this endpoint. Clear this bit to disable the interrupts for this endpoint.					
0	EPOINTE	Endpoint 0 Interrupt Enable Set this bit to enable the interrupts for this endpoint. Clear this bit to disable the interrupts for this endpoint.					

Reset Value = 0000 0000b

Serial I/O Port

The serial I/O port in the AT83R5122, AT8xC5122/23 is compatible with the serial I/O port in the 80C52.

The I/O port provides both synchronous and asynchronous communication modes. It operates as an Universal Asynchronous Receiver and Transmitter (UART) in three full-duplex modes (Modes 1, 2 and 3). Asynchronous transmission and reception can occur simultaneously and at different baud rates

Serial I/O port includes the following enhancements:

- Framing error detection
- Automatic address recognition

Framing Error Detection

Framing bit error detection is provided for the three asynchronous modes (Modes 1, 2 and 3). To enable the framing bit error detection feature, set SMOD0 bit in PCON register (See Figure 64).

Figure 64. Framing Error Block Diagram

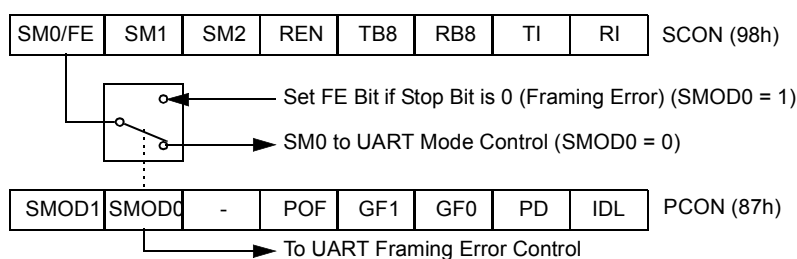

When this feature is enabled, the receiver checks each incoming data frame for a valid stop bit. An invalid stop bit may result from noise on the serial lines or from simultaneous transmission by two CPUs. If a valid stop bit is not found, the Framing Error bit (FE) in SCON register (See Figure 69 on page 128) bit is set.

Software may examine FE bit after each reception to check for data errors. Once set, only software or a reset can clear FE bit. Subsequently received frames with valid stop bits cannot clear FE bit. When FE feature is enabled, RI rises on stop bit instead of the last data bit (See Figure 65 and Figure 66).

Figure 65. UART Timings in Mode 1

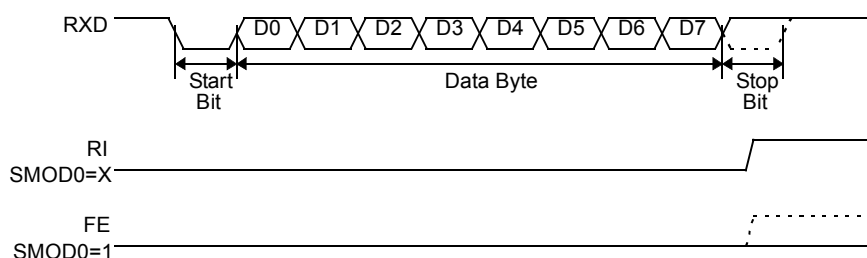
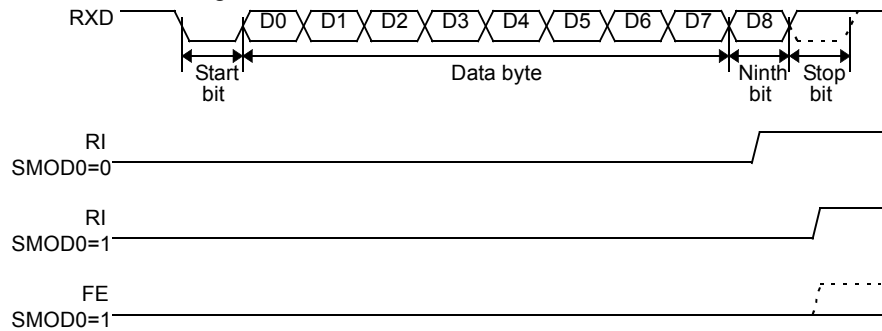

Figure 66. UART Timings in Modes 2 and 3



Automatic Address Recognition

The automatic address recognition feature is enabled when the multiprocessor communication feature is enabled (SM2 bit in SCON register is set).

Implemented in hardware, automatic address recognition enhances the multiprocessor communication feature by allowing the serial port to examine the address of each incoming command frame. Only when the serial port recognizes its own address, the receiver sets RI bit in SCON register to generate an interrupt. This ensures that the CPU is not interrupted by command frames addressed to other devices.

If desired, you may enable the automatic address recognition feature in mode 1. In this configuration, the stop bit takes the place of the ninth data bit. Bit RI is set only when the received command frame address matches the device's address and is terminated by a valid stop bit.

To support automatic address recognition, a device is identified by a given address and a broadcast address.

Note: The multiprocessor communication and automatic address recognition features cannot be enabled in mode 0 (i.e. setting SM2 bit in SCON register in mode 0 has no effect).

Given Address

Each device has an individual address that is specified in SADDR register; the SADEN register is a mask byte that contains don't care bits (defined by zeros) to form the device's given address. The don't care bits provide the flexibility to address one or more slaves at a time. The following example illustrates how a given address is formed.

To address a device by its individual address, the SADEN mask byte must be 1111 1111b.

For example:

```
SADDR0101 0110b
SADEN1111 1100b
Given0101 01XXb
```

The following is an example of how to use given addresses to address different slaves:

```
Slave A:SADDR1111 0001b
SADEN1111 1010b
Given1111 0X0Xb
```

```
Slave B:SADDR1111 0011b
SADEN1111 1001b
Given1111 0XX1b
```

```
Slave C:SADDR1111 0011b
SADEN1111 1101b
Given1111 00X1b
```



The SADEN byte is selected so that each slave may be addressed separately. For slave A, bit 0 (the LSB) is a don't care bit; for slaves B and C, bit 0 is a 1. To communicate with slave A only, the master must send an address where bit 0 is clear (e.g. 1111 0000b). For slave A, bit 1 is a 1; for slaves B and C, bit 1 is a don't care bit. To communicate with slaves B and C, but not slave A, the master must send an address with bits 0 and 1 both set (e.g. 1111 0011b). To communicate with slaves A, B and C, the master must send an address with bit 0 set, bit 1 clear, and bit 2 clear (e.g. 1111 0001b).

Broadcast Address

A broadcast address is formed from the logical OR of the SADDR and SADEN registers with zeros defined as don't care bits, e.g.:

```
SADDR0101 0110b
SADEN1111 1100b
Broadcast =SADDR OR SADEN1111 111Xb
```

The use of don't care bits provides flexibility in defining the broadcast address, however in most applications, a broadcast address is FFh. The following is an example of using broadcast addresses:

```
Slave A:SADDR1111 0001b
      SADEN1111 1010b
Broadcast1111 1X11b,
```

```
Slave B:SADDR1111 0011b
      SADEN1111 1001b
Broadcast1111 1X11B,
```

```
Slave C:SADDR=1111 0010b
      SADEN1111 1101b
Broadcast1111 1111b
```

For slaves A and B, bit 2 is a don't care bit; for slave C, bit 2 is set. To communicate with all of the slaves, the master must send an address FFh. To communicate with slaves A and B, but not slave C, the master can send an address FBh.

Reset Addresses

On reset, the SADDR and SADEN registers are initialized to 00h, i.e. the given and broadcast addresses are XXXX XXXXb (all don't care bits). This ensures that the serial port will reply to any address, and so, that it is backwards compatible with the 80C51 microcontrollers that does not support automatic address recognition.

Timer 1

When using the Timer 1, the Baud Rate is derived from the overflow of the timer. As shown in Figure 67 the Timer 1 is used in its 8-bit auto-reload mode). SMOD1 bit in PCON register allows doubling of the generated baud rate.

Figure 67. Timer 1 Baud Rate Generator Block Diagram

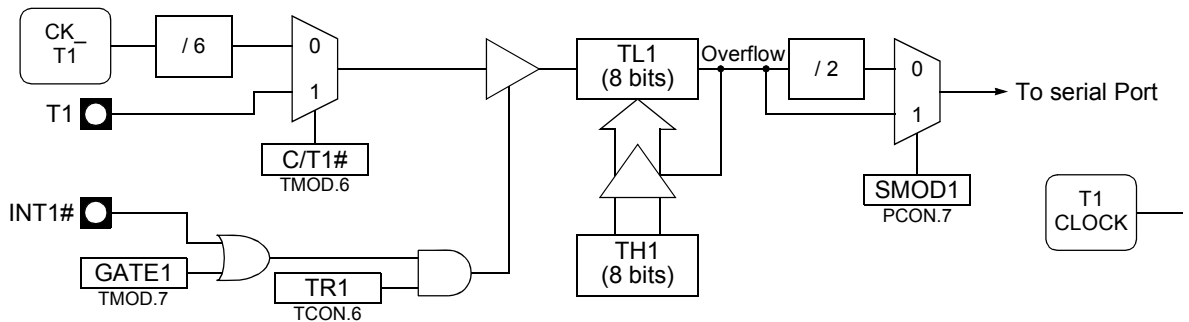

Internal Baud Rate Generator

When using the Internal Baud Rate Generator, the Baud Rate is derived from the overflow of the timer. As shown in Figure 68 the Internal Baud Rate Generator is an 8-bit auto-reload timer feed by the peripheral clock or by the peripheral clock divided by 6 depending on the SPD bit in BDRCON register (see Table 82 on page 134). The Internal Baud Rate Generator is enabled by setting BRR bit in BDRCON register. SMOD1 bit in PCON register allows doubling of the generated baud rate.

Figure 68. Internal Baud Rate Generator Block Diagram

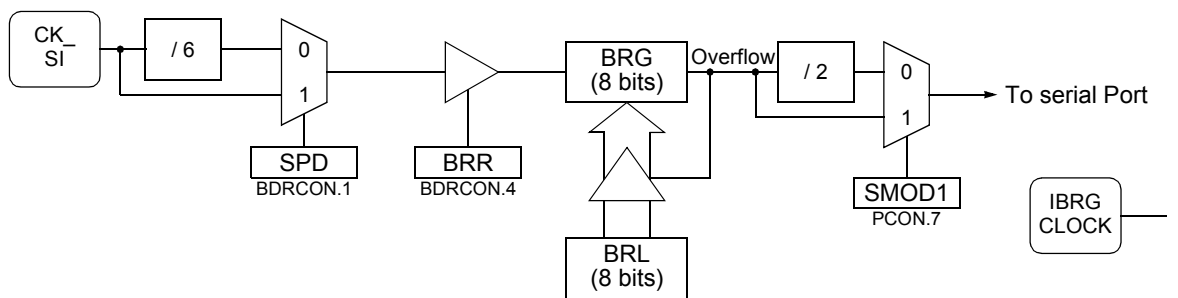

Synchronous Mode (Mode 0)

Mode 0 is a half-duplex, synchronous mode, which is commonly used to expand the I/O capabilities of a device with shift registers. The transmit data (TXD) pin outputs a set of eight clock pulses while the receive data (RXD) pin transmits or receives a byte of data. The 8-bit data are transmitted and received least-significant bit (LSB) first. Shifts occur at a fixed Baud Rate (see Section “Baud Rate Selection (Mode 0)”). Figure 69 shows the serial port block diagram in Mode 0.

Figure 69. Serial I/O Port Block Diagram (Mode 0)

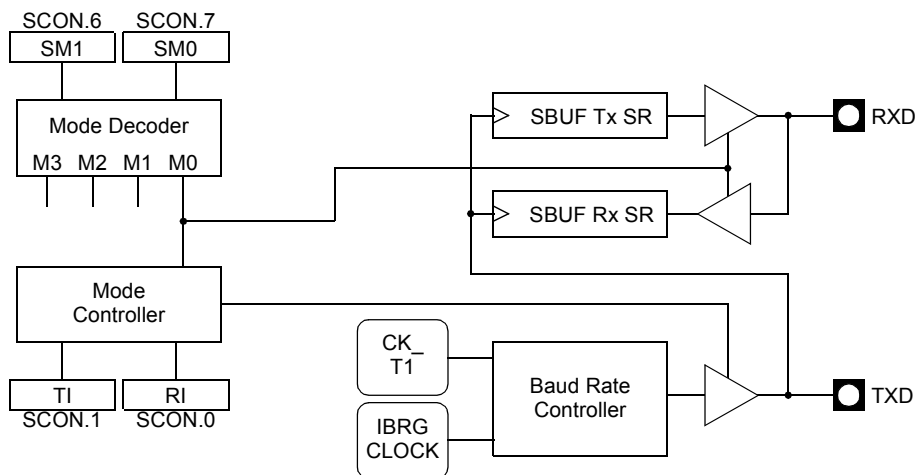

Transmission (Mode 0)

To start a transmission mode 0, write to SCON register clearing bits SM0, SM1. As shown in Figure 70, writing the byte to SBUF register starts the transmission. Hardware shifts the LSB (D0) onto the RXD pin during the first clock cycle composed of a high level then low level signal on TXD. During the eighth clock cycle the MSB (D7) is on the RXD pin. Then, hardware drives the RXD pin high and asserts TI to indicate the end of the transmission.

Figure 70. Transmission Waveforms (Mode 0)

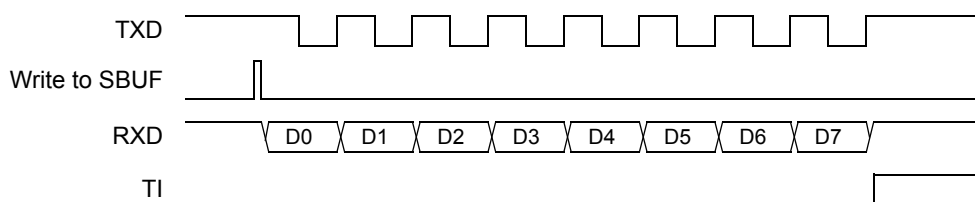

Reception (Mode 0)

To start a reception in mode 0, write to SCON register clearing SM0, SM1 and RI bits and setting the REN bit.

As shown in Figure 71, Clock is pulsed and the LSB (D0) is sampled on the RXD pin. The D0 bit is then shifted into the shift register. After eight sampling, the MSB (D7) is shifted into the shift register, and hardware asserts RI bit to indicate a completed reception. Software can then read the received byte from SBUF register.

Figure 71. Reception Waveforms (Mode 0)

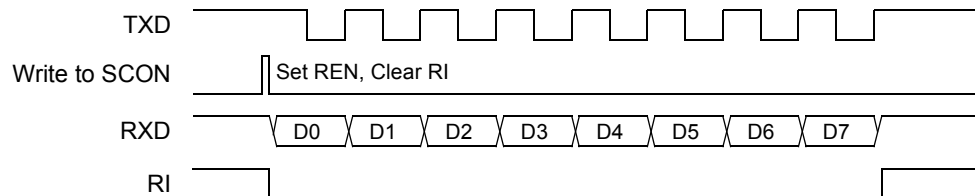

Baud Rate Selection (Mode 0) In mode 0, baud rate can be either fixed or variable.

As shown in Figure 72, the selection is done using MOSRC bit in BDRCON register.

Figure 73 gives the baud rate calculation formulas for each baud rate source.

Figure 72. Baud Rate Source Selection (Mode 0)

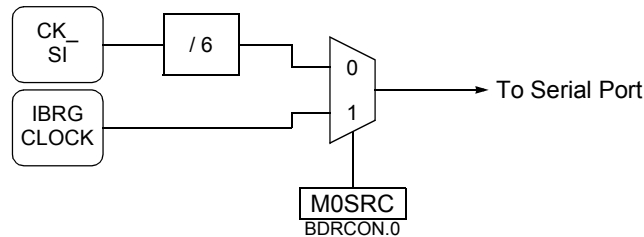

Figure 73. Baud Rate Formulas (Mode 0)

$$\text{Baud_Rate} = \frac{F_{\text{CK_SI}}}{6}$$

a. Fixed Formula

$$\text{Baud_Rate} = \frac{2^{\text{SMOD1}} \cdot F_{\text{CK_SI}}}{6^{(1-\text{SPD})} \cdot 32 \cdot (256 - \text{BRL})}$$

$$\text{BRL} = 256 - \frac{2^{\text{SMOD1}} \cdot F_{\text{CK_SI}}}{6^{(1-\text{SPD})} \cdot 32 \cdot \text{Baud_Rate}}$$

b. Variable Formula

Asynchronous Modes (Modes 1, 2 and 3)

The Serial Port has one 8-bit and two 9-bit asynchronous modes of operation. Figure 74 shows the Serial Port block diagram in such asynchronous modes.

Figure 74. Serial I/O Port Block Diagram (Modes 1, 2 and 3)

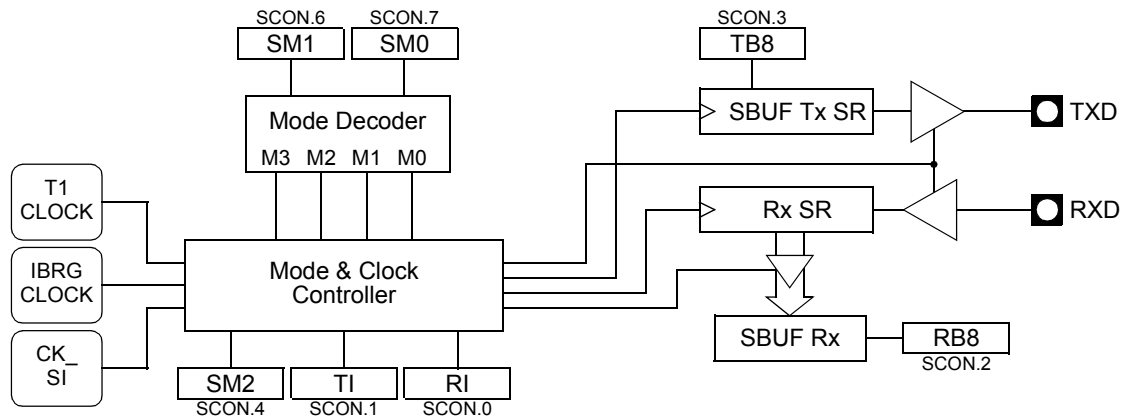

Mode 1

Mode 1 is a full-duplex, asynchronous mode. The data frame (see Figure 75) consists of 10 bits: one start, eight data bits and one stop bit. Serial data is transmitted on the TXD pin and received on the RXD pin. When a data is received, the stop bit is read in the RB8 bit in SCON register.

Figure 75. Data Frame Format (Mode 1)

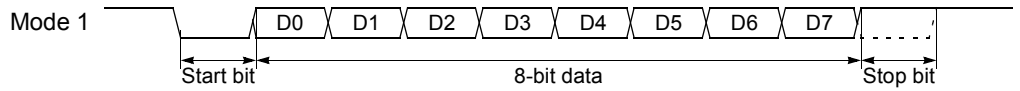

Modes 2 and 3

Modes 2 and 3 are full-duplex, asynchronous modes. The data frame (see Figure 76) consists of 11 bits: one start bit, eight data bits (transmitted and received LSB first), one programmable ninth data bit and one stop bit. Serial data is transmitted on the TXD pin and received on the RXD pin. On receive, the ninth bit is read from RB8 bit in SCON register. On transmit, the ninth data bit is written to TB8 bit in SCON register. Alternatively, you can use the ninth bit as a command/data flag.

Figure 76. Data Frame Format (Modes 2 and 3)

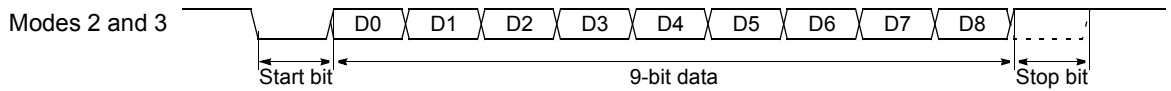

Transmission (Modes 1, 2 and 3)

To initiate a transmission, write to SCON register, setting SM0 and SM1 bits according to Figure 69 on page 128, and setting the ninth bit by writing to TB8 bit. Then, writing the byte to be transmitted to SBUF register starts the transmission.

Reception (Modes 1, 2 and 3)

To prepare for a reception, write to SCON register, setting SM0 and SM1 bits according to Figure 69 on page 128, and setting REN bit. The actual reception is then initiated by a detected high-to-low transition on the RXD pin.

Framing Error Detection (Modes 1, 2 and 3)

Framing error detection is provided for the three asynchronous modes. To enable the framing bit error detection feature, set SMOD0 bit in PCON register as shown in Figure 77.

When this feature is enabled, the receiver checks each incoming data frame for a valid stop bit. An invalid stop bit may result from noise on the serial lines or from simultaneous transmission by two devices. If a valid stop bit is not found, the software sets FE bit in SCON register.

Software may examine FE bit after each reception to check for data errors. Once set, only software or a chip reset clear FE bit. Subsequently received frames with valid stop bits cannot clear FE bit. When the framing error detection feature is enabled, RI rises on stop bit instead of the last data bit as detailed in Figure 75 and Figure 76.

Figure 77. Framing Error Block Diagram

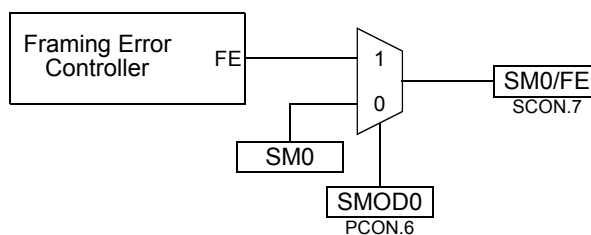

Baud Rate Selection (Modes 1 and 3)

In modes 1 and 3, the Baud Rate is derived either from the Timer 1 or the Internal Baud Rate Generator and allows different baud rate in reception and transmission.

As shown in Figure 78 the selection is done using RBCK and TBCK bits in BDRCON register.

Figure 79 gives the baud rate calculation formulas for each baud rate source while Table 76 details Internal Baud Rate Generator configuration for different peripheral clock frequencies and giving baud rates closer to the standard baud rates.

Figure 78. Baud Rate Source Selection (Modes 1 and 3)

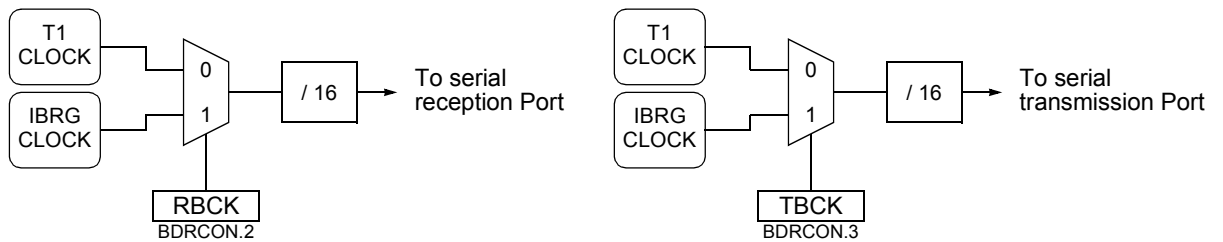

Figure 79. Baud Rate Formulas (Modes 1 and 3)

$$\text{Baud_Rate} = \frac{2^{\text{SMOD}1} \cdot F_{\text{CK_SI}}}{6^{(1-\text{SPD})} \cdot 32 \cdot (256 - \text{BRL})}$$

$$\text{BRL} = 256 - \frac{2^{\text{SMOD}1} \cdot F_{\text{CK_SI}}}{6^{(1-\text{SPD})} \cdot 32 \cdot \text{Baud_Rate}}$$

a. IBRG Formula

$$\text{Baud_Rate} = \frac{2^{\text{SMOD}1} \cdot F_{\text{CK_T1}}}{192 \cdot (256 - \text{TH1})}$$

$$\text{TH1} = 256 - \frac{2^{\text{SMOD}1} \cdot F_{\text{CK_T1}}}{192 \cdot \text{Baud_Rate}}$$

b. T1 Formula

Table 76. Internal Baud Rate Generator Value

Baud Rate	F _{CK_IDLE} = 4 MHz				F _{CK_IDLE} = 8 MHz				F _{CK_IDLE} = 9.6 MHz			
	SPD	SMOD1	BRL	Error%	SPD	SMOD1	BRL	Error%	SPD	SMOD1	BRL	Error%
115200	1	1	254	8.51	1	1	252	8.51	1	1	251	4.17
57600	1	1	252	8.51	1	1	247	3.55	1	1	246	4.17
38400	1	1	249	6.99	1	1	243	0.16	1	1	240	2.34
19200	1	1	243	0.16	1	1	230	0.16	1	1	225	0.81
9600	1	1	230	0.16	1	1	204	0.16	1	1	194	0.81
4800	1	1	204	0.16	1	1	152	0.16	1	1	131	0.00

Baud Rate	F _{CK_IDLE} = 12 MHz				F _{CK_IDLE} = 16 MHz				F _{CK_IDLE} = 24 MHz			
	SPD	SMOD1	BRL	Error%	SPD	SMOD1	BRL	Error%	SPD	SMOD1	BRL	Error%
115200	1	1	249	6.99	1	1	247	3.55	1	1	243	0.16
57600	1	1	243	0.16	1	1	239	2.12	1	1	230	0.16
38400	1	1	236	2.34	1	1	230	0.16	1	1	217	0.16
19200	1	1	217	0.16	1	1	204	0.16	1	1	178	0.16
9600	1	1	178	0.16	1	1	152	0.16	1	1	100	0.16
4800	1	1	100	0.16	1	1	48	0.16	1	1	N/A	N/A

Baud Rate Selection (Mode 2) In mode 2, the baud rate can only be programmed to two fixed values: 1/16 or 1/32 of the peripheral clock frequency.

As shown in Figure 80 the selection is done using SMOD1 bit in PCON register.

Figure 81 gives the baud rate calculation formula depending on the selection.

Figure 80. Baud Rate Generator Selection (Mode 2)

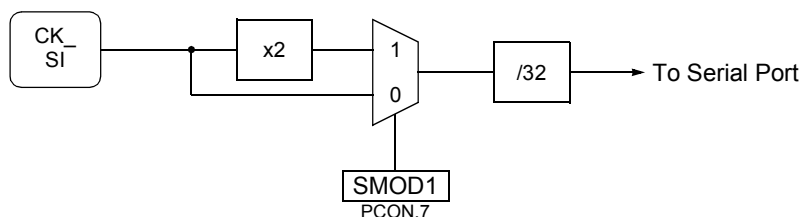

Figure 81. Baud Rate Formula (Mode 2)

$$\text{Baud_Rate} = \frac{2^{\text{SMOD1}} \cdot F_{\text{ck_sl}}}{32}$$

For mode 0 for UART, thanks to the bit M0SRC located in BDRCON register (Table 82)

Registers

Table 77. Serial Control Register - SCON (98h)

	7	6	5	4	3	2	1	0
	FE/SM0	SM1	SM2	REN	TB8	RB8	TI	RI

Bit Number	Bit Mnemonic	Description																				
7	FE	Framing Error bit (SMOD0=1) Clear to reset the error state, not cleared by a valid stop bit. Set by hardware when an invalid stop bit is detected. SMOD0 in PCON register must be set to enable access to the FE bit																				
	SM0	Serial Port Mode bit 0 (SMOD0=0) Refer to SM1 for serial port mode selection. SMOD0 in PCON register must be cleared to enable access to the SM0 bit																				
6	SM1	Serial port Mode bit 1 <table style="width: 100%; border-collapse: collapse;"> <thead> <tr> <th style="width: 10%;"><u>SM0</u></th> <th style="width: 10%;"><u>SM1</u></th> <th style="width: 10%;"><u>Mode</u></th> <th style="width: 70%;"><u>Description</u><u>Baud Rate</u></th> </tr> </thead> <tbody> <tr> <td>0</td> <td>0</td> <td>0</td> <td>Shift Register $F_{CK_IDLE}/6$</td> </tr> <tr> <td>0</td> <td>1</td> <td>1</td> <td>8-bit UART Variable</td> </tr> <tr> <td>1</td> <td>0</td> <td>2</td> <td>9-bit UART $F_{CK_IDLE}/32$ or $/16$</td> </tr> <tr> <td>1</td> <td>1</td> <td>3</td> <td>9-bit UART Variable</td> </tr> </tbody> </table>	<u>SM0</u>	<u>SM1</u>	<u>Mode</u>	<u>Description</u> <u>Baud Rate</u>	0	0	0	Shift Register $F_{CK_IDLE}/6$	0	1	1	8-bit UART Variable	1	0	2	9-bit UART $F_{CK_IDLE}/32$ or $/16$	1	1	3	9-bit UART Variable
<u>SM0</u>	<u>SM1</u>	<u>Mode</u>	<u>Description</u> <u>Baud Rate</u>																			
0	0	0	Shift Register $F_{CK_IDLE}/6$																			
0	1	1	8-bit UART Variable																			
1	0	2	9-bit UART $F_{CK_IDLE}/32$ or $/16$																			
1	1	3	9-bit UART Variable																			
5	SM2	Serial port Mode 2 bit/Multiprocessor Communication Enable bit Clear to disable multiprocessor communication feature. Set to enable multiprocessor communication feature in mode 2 and 3, and eventually mode 1. This bit should be cleared in mode 0.																				
4	REN	Reception Enable bit Clear to disable serial reception. Set to enable serial reception.																				
3	TB8	Transmitter Bit 8/Ninth bit to transmit in modes 2 and 3 Clear to transmit a logic 0 in the 9th bit. Set to transmit a logic 1 in the 9th bit.																				
2	RB8	Receiver Bit 8/Ninth bit received in modes 2 and 3 Cleared by hardware if 9th bit received is a logic 0. Set by hardware if 9th bit received is a logic 1. In mode 1, if SM2 = 0, RB8 is the received stop bit. In mode 0 RB8 is not used.																				
1	TI	Transmit Interrupt flag Clear to acknowledge interrupt. Set by hardware at the end of the 8th bit time in mode 0 or at the beginning of the stop bit in the other modes. This bit can also be set by software.																				
0	RI	Receive Interrupt flag Clear to acknowledge interrupt. Set by hardware at the end of the 8th bit time in mode 0, see Figure 65 and Figure 66 in the other modes. This bit can also be set by software.																				

Reset Value = 0000 0000b (Bit addressable)

Table 78. Slave Address Mask Register for UART - SADEN (B9h)

7	6	5	4	3	2	1	0

Reset Value = 0000 0000b

Table 79. Slave Address Register for UART - SADDR (A9h)

7	6	5	4	3	2	1	0

Reset Value = 0000 0000b

Table 80. Serial Buffer Register for UART - SBUF (99h)

7	6	5	4	3	2	1	0

Reset Value = XXXX XXXXb

Table 81. Baud Rate Reload Register for the internal baud rate generator, UART - BRL (9Ah)

7	6	5	4	3	2	1	0

Reset Value = 0000 0000b

Table 82. Baud Rate Control Register - BDRCON - (9Bh)

7	6	5	4	3	2	1	0
-	-	-	BRR	TBCK	RBCK	SPD	M0SRC

Bit Number	Bit Mnemonic	Description
7 - 5	-	Reserved The value read from this bit is indeterminate. Do not change these bits.
4	BRR	Baud Rate Run Control bit Cleared to stop the internal Baud Rate Generator. Set to start the internal Baud Rate Generator.
3	TBCK	Transmission Baud rate Generator Selection bit for UART Cleared to select Timer 1 for the Baud Rate Generator. Set to select internal Baud Rate Generator.
2	RBCK	Reception Baud Rate Generator Selection bit for UART Cleared to select Timer 1 for the Baud Rate Generator. Set to select internal Baud Rate Generator.
1	SPD	Baud Rate Speed Control bit for UART Cleared to select the SLOW Baud Rate Generator. Set to select the FAST Baud Rate Generator.
0	M0SRC	Baud Rate Source select bit in Mode 0 for UART Cleared to select $F_{CK_SI}/6$ as the Baud Rate Generator. Set to select the internal Baud Rate Generator for UART in mode 0.

Reset Value = XXX0 0000b (Not bit addressable)

Serial Port Interface (SPI)

Only for AT8xC5122.

The Serial Peripheral Interface module (SPI) which allows full-duplex, synchronous, serial communication between the MCU and peripheral devices, including other MCUs.

Features

Features of the SPI module include the following:

- Full-duplex, three-wire synchronous transfers
- Master or Slave operation
- Eight programmable Master clock rates
- Serial clock with programmable polarity and phase
- Master Mode fault error flag with MCU interrupt capability
- Write collision flag protection

Signal Description

Figure 82 shows a typical SPI bus configuration using one Master controller and many Slave peripherals. The bus is made of three wires connecting all the devices:

Figure 82. Typical SPI Bus

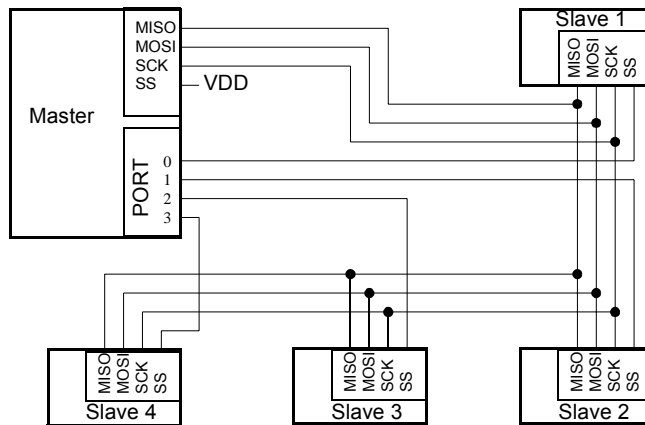

The Master device selects the individual Slave devices by using four pins of a parallel port to control the four \overline{SS} pins of the Slave devices.

Master Output Slave Input (MOSI)

This 1-bit signal is directly connected between the Master Device and a Slave Device. The MOSI line is used to transfer data in series from the Master to the Slave. Therefore, it is an output signal from the Master, and an input signal to a Slave. A byte (8-bit word) is transmitted most significant bit (MSB) first, least significant bit (LSB) last.

Master Input Slave Output (MISO)

This 1-bit signal is directly connected between the Slave Device and a Master Device. The MISO line is used to transfer data in series from the Slave to the Master. Therefore, it is an output signal from the Slave, and an input signal to the Master. A byte (8-bit word) is transmitted most significant bit (MSB) first, least significant bit (LSB) last.

SPI Serial Clock (SCK)

This signal is used to synchronize the data movement both in and out the devices through their MOSI and MISO lines. It is driven by the Master for eight clock cycles which allows to exchange one byte on the serial lines.

Slave Select (\overline{SS})

Each Slave peripheral is selected by one Slave Select pin (\overline{SS}). This signal must stay low for any message for a Slave. Only one Master (\overline{SS} high level) can drive the network. The Master may select each Slave device by software through port pins (Figure 82). To prevent bus conflicts on the MISO line, only one slave should be selected at a time by the Master for a transmission.

In a Master configuration, the \overline{SS} line can be used in conjunction with the MODF flag in the SPI Status register (SPSTA) to prevent multiple masters from driving MOSI and SCK (see Section “Error Conditions”, page 140).

A high level on the \overline{SS} pin puts the MISO line of a Slave SPI in a high-impedance state.

The \overline{SS} pin could be used as a general-purpose if the following conditions are met:

- The device is configured as a Master and the SSDIS control bit in SPCON is set. This kind of configuration can be found when only one Master is driving the network and there is no way that the \overline{SS} pin will be pulled low. Therefore, the MODF flag in the SPSTA will never be set ⁽¹⁾.
- The Device is configured as a Slave with CPHA and SSDIS control bits set ⁽²⁾. This kind of configuration can happen when the system comprises one Master and one Slave only. Therefore, the device should always be selected and there is no reason that the Master uses the \overline{SS} pin to select the communicating Slave device.

Baud Rate

In Master mode, the baud rate can be selected from a baud rate generator which is controlled by three bits in the SPCON register: SPR2, SPR1 and SPR0. The Master clock is chosen from one of six clock rates resulting from the division of the internal clock by 4, 8, 16, 32, 64 or 128.

Table 83 gives the different clock rates selected by SPR2:SPR1:SPR0

Table 83. SPI Master Baud Rate Selection

SPR2:SPR1:SPR0	Clock Rate	Baud Rate Divisor (BD)
000	Reserved	N/A
001	$F_{CK_SPI} / 4$	4
010	$F_{CK_SPI} / 8$	8
011	$F_{CK_SPI} / 16$	16
100	$F_{CK_SPI} / 32$	32
101	$F_{CK_SPI} / 64$	64
110	$F_{CK_SPI} / 128$	128
111	Reserved	N/A

1. Clearing SSDIS control bit does not clear MODF.
2. Special care should be taken not to set SSDIS control bit when CPHA = '0' because in this mode, the \overline{SS} is used to start the transmission.

Functional Description

Figure 83 shows a detailed structure of the SPI module.

Figure 83. SPI Module Block Diagram

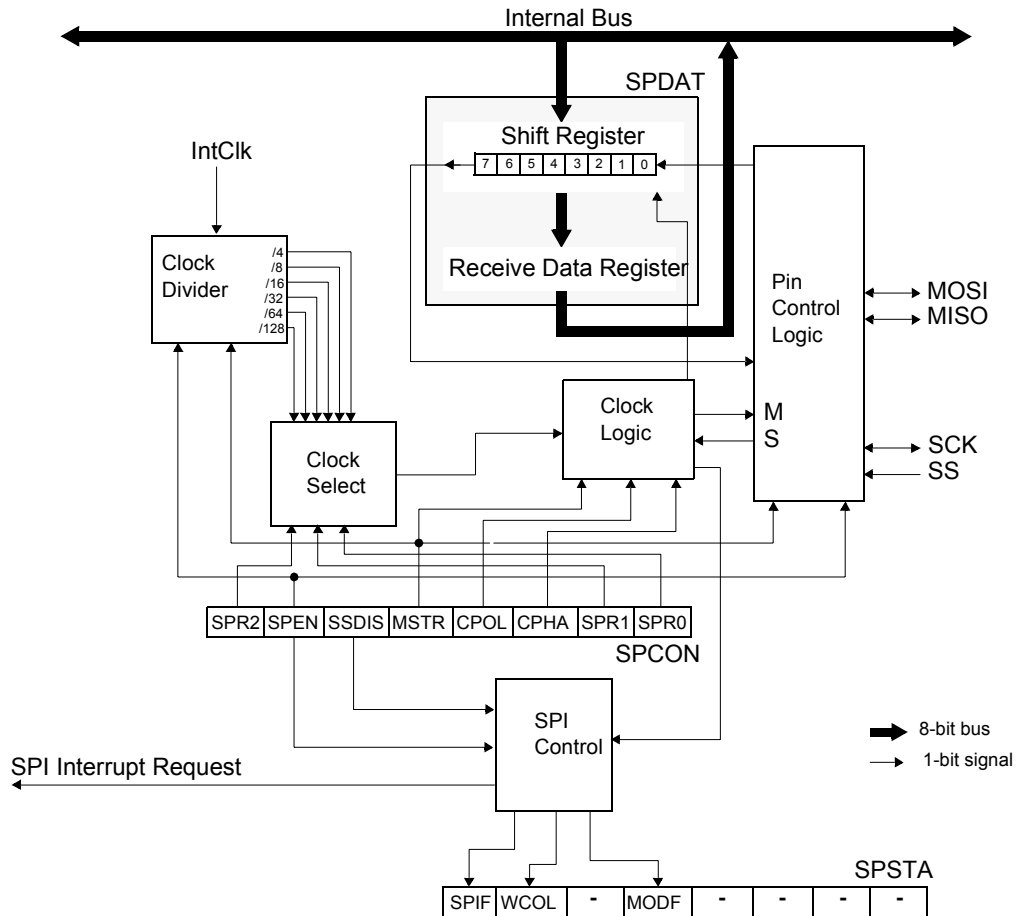

Operating Modes

The Serial Peripheral Interface can be configured as one of the two modes: Master mode or Slave mode. The configuration and initialization of the SPI module is made through one register:

- The Serial Peripheral Control register (SPCON)

Once the SPI is configured, the data exchange is made using:

- SPCON
- The Serial Peripheral Status register (SPSTA)
- The Serial Peripheral Data register (SPDAT)

During an SPI transmission, data is simultaneously transmitted (shifted out serially) and received (shifted in serially). A serial clock line (SCK) synchronizes shifting and sampling on the two serial data lines (MOSI and MISO). A Slave Select line (\overline{SS}) allows individual selection of a Slave SPI device; Slave devices that are not selected do not interfere with SPI bus activities.

When the Master device transmits data to the Slave device via the MOSI line, the Slave device responds by sending data to the Master device via the MISO line. This implies full-duplex transmission with both data out and data in synchronized with the same clock (Figure 84).

Figure 84. Full-duplex Master-Slave Interconnection

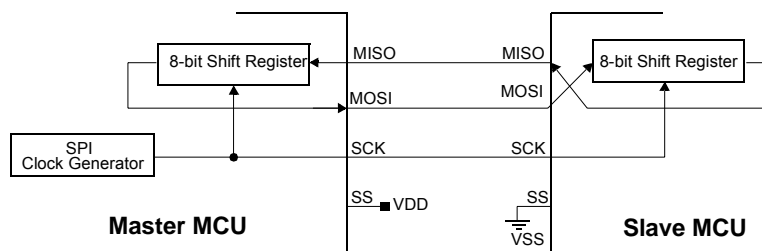

Master Mode

The SPI operates in Master mode when the Master bit, MSTR⁽³⁾, in the SPCON register is set. Only one Master SPI device can initiate transmissions. Software begins the transmission from a Master SPI module by writing to the Serial Peripheral Data Register (SPDAT). If the shift register is empty, the byte is immediately transferred to the shift register. The byte begins shifting out on MOSI pin under the control of the serial clock, SCK. Simultaneously, another byte shifts in from the Slave on the Master's MISO pin. The transmission ends when the Serial Peripheral transfer data flag, SPIF, in SPSTA becomes set. At the same time that SPIF becomes set, the received byte from the Slave is transferred to the receive data register in SPDAT. Software clears SPIF by reading the Serial Peripheral Status register (SPSTA) with the SPIF bit set, and then reading the SPDAT.

When the pin SS is pulled down during a transmission, the data is interrupted and when the transmission is established again, the data present in the SPDAT is resent.

Slave Mode

The SPI operates in Slave mode when the Master bit, MSTR⁽⁴⁾, in the SPCON register is cleared. Before a data transmission occurs, the Slave Select pin, \overline{SS} , of the Slave device must be set to '0'. \overline{SS} must remain low until the transmission is complete.

In a Slave SPI module, data enters the shift register under the control of the SCK from the Master SPI module. After a byte enters the shift register, it is immediately transferred to the receive data register in SPDAT, and the SPIF bit is set. To prevent an overflow condition, Slave software must then read the SPDAT before another byte enters the shift register⁽⁵⁾. A Slave SPI must complete the write to the SPDAT (shift register) at least one bus cycle before the Master SPI starts a transmission. If the write to the data register is late, the SPI transmits the data already in the shift register from the previous transmission.

Transmission Formats

Software can select any of four combinations of serial clock (SCK) phase and polarity using two bits in the SPCON: the Clock Polarity (CPOL⁽⁶⁾) and the Clock Phase (CPHA⁽⁴⁾). CPOL defines the default SCK line level in idle state. It has no significant effect on the transmission format. CPHA defines the edges on which the input data are sampled and the edges on which the output data are shifted (Figure 85 and Figure 86). The clock phase and polarity should be identical for the Master SPI device and the communicating Slave device.

3. The SPI module should be configured as a Master before it is enabled (SPEN set). Also the Master SPI should be configured before the Slave SPI.
4. The SPI module should be configured as a Slave before it is enabled (SPEN set).
5. The maximum frequency of the SCK for an SPI configured as a Slave is the bus clock speed.
6. Before writing to the CPOL and CPHA bits, the SPI should be disabled (SPEN = '0').

Figure 85. Data Transmission Format (CPHA = 0)

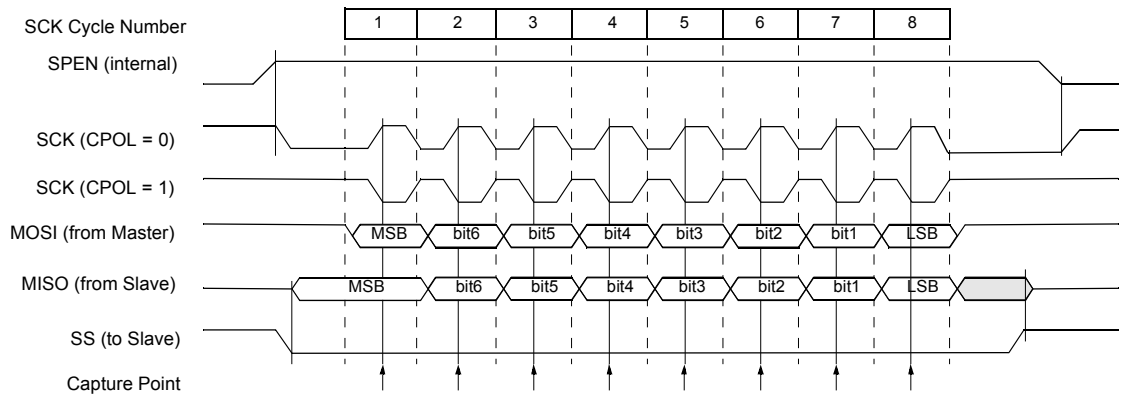
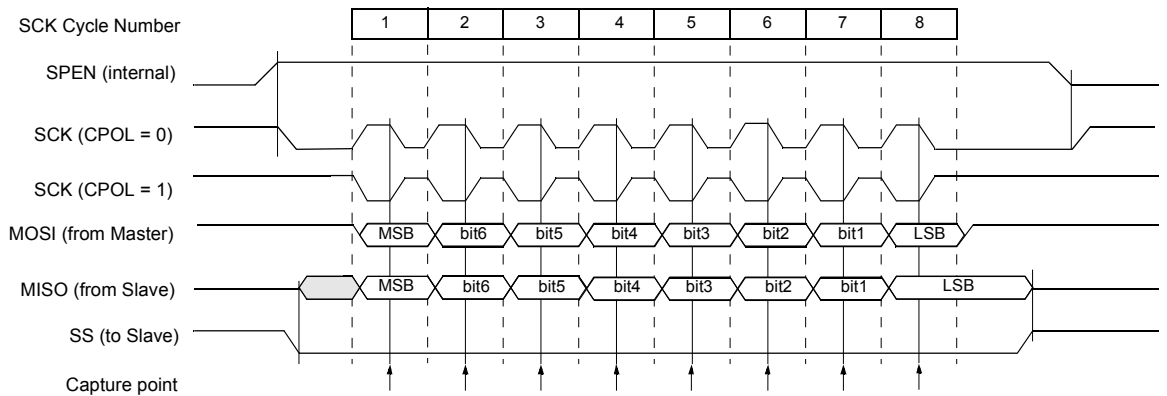

Figure 86. Data Transmission Format (CPHA = 1)



As shown in Figure 85, the first SCK edge is the MSB capture strobe. Therefore the Slave must begin driving its data before the first SCK edge, and a falling edge on the \overline{SS} pin is used to start the transmission. The \overline{SS} pin must be toggled high and then low between each byte transmitted (Figure 87).

Figure 87. CPHA/ \overline{SS} Timing

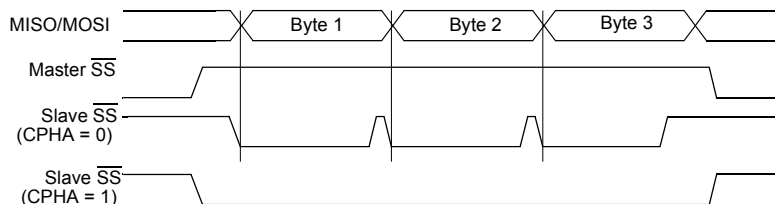

Figure 86 shows an SPI transmission in which CPHA is "1". In this case, the Master begins driving its MOSI pin on the first SCK edge. Therefore, the Slave uses the first SCK edge as a start transmission signal. The \overline{SS} pin can remain low between transmis-



sions (Figure 87). This format may be preferable in systems having only one Master and only one Slave driving the MISO data line.

Error Conditions

Mode Fault (MODF)

The following flags in the SPSTA signal SPI error conditions.

MODF error bit in Master mode SPI indicates that the level on the Slave Select (\overline{SS}) pin is inconsistent with the actual mode of the device. MODF is set to warn that there may have a multi-master conflict for system control. In this case, the SPI system is affected in the following ways:

- An SPI receiver/error CPU interrupt request is generated.
- The SPEN bit in SPCON is cleared. This disable the SPI.
- The MSTR bit in SPCON is cleared.

When \overline{SS} Disable (SSDIS) bit in the SPCON register is cleared, the MODF flag is set when the \overline{SS} signal becomes '0'.

However, as stated before, for a system with one Master, if the \overline{SS} pin of the Master device is pulled low, there is no way that another Master is attempting to drive the network. In this case, to prevent the MODF flag from being set, software can set the SSDIS bit in the SPCON register and therefore making the \overline{SS} pin as a general-purpose I/O pin.

Clearing the MODF bit is accomplished by a read of SPSTA register with MODF bit set, followed by a write to the SPCON register. SPEN Control bit may be restored to its original set state after the MODF bit has been cleared.

Write Collision (WCOL)

A Write Collision (WCOL) flag in the SPSTA is set when a write to the SPDAT register is done during a transmit sequence.

WCOL does not cause an interruption, and the transfer continues uninterrupted.

Clearing the WCOL bit is done through a software sequence of an access to SPSTA and an access to SPDAT.

Overrun Condition

An overrun condition occurs when the Master device tries to send several data bytes and the Slave device has not cleared the SPIF bit issuing from the previous data byte transmitted. In this case, the receiver buffer contains the byte sent after the SPIF bit was last cleared. A read of the SPDAT returns this byte. All others bytes are lost.

This condition is not detected by the SPI peripheral.

SS Error Flag (SSERR)

A Synchronous Serial Slave Error occurs when \overline{SS} goes high before the end of a received data in slave mode. SSERR does not cause in interruption, this bit is cleared by writing 0 to SPEN bit (reset of the SPI state machine).

Interrupts

Two SPI status flags can generate a CPU interrupt requests:

Table 84. SPI Interrupts

Flag	Request
SPIF (SP data transfer)	SPI Transmitter Interrupt request
MODF (Mode Fault)	SPI Receiver/Error Interrupt Request (if SSDIS = '0')

Serial Peripheral data transfer flag, SPIF: This bit is set by hardware when a transfer has been completed. SPIF bit generates transmitter CPU interrupt requests.

Mode Fault flag, MODF: This bit becomes set to indicate that the level on the \overline{SS} is inconsistent with the mode of the SPI. MODF with SSDIS reset, generates receiver/error CPU interrupt requests.

Figure 88 gives a logical view of the above statements.

Figure 88. SPI Interrupt Requests Generation

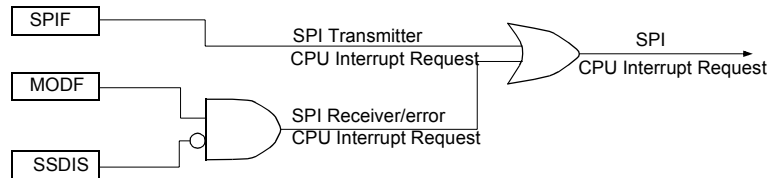

Registers

There are three registers in the module that provide control, status and data storage functions. These registers are described in the following paragraphs.

Serial Peripheral Control Register (SPCON)

The Serial Peripheral Control Register does the following:

- Selects one of the Master clock rates
- Configures the SPI module as Master or Slave
- Selects serial clock polarity and phase
- Enables the SPI module
- Frees the \overline{SS} pin for a general-purpose

Table 85. Serial Peripheral Control Register - SPCON (C3h)

7	6	5	4	3	2	1	0
SPR2	SPEN	SSDIS	MSTR	CPOL	CPHA	SPR1	SPR0
Bit Number	Bit Mnemonic	R/W Mode	Description				
7	SPR2	RW	Serial Peripheral Rate 2 Bit with SPR1 and SPR0 define the clock rate				
6	SPEN	RW	Serial Peripheral Enable Clear to disable the SPI interface (internal reset of the SPI) Set to enable the SPI interface				
5	SSDIS	RW	\overline{SS} Disable Clear to enable \overline{SS} in both Master and Slave modes Set to disable \overline{SS} in both Master and Slave modes. In Slave mode, this bit has no effect if CPHA = '0'				
4	MSTR	RW	Serial Peripheral Master Clear to configure the SPI as a Slave Set to configure the SPI as a Master				
3	CPOL	RW	Clock Polarity Clear to have the SCK set to '0' in idle state Set to have the SCK set to '1' in idle low				
2	CPHA	RW	Clock Phase Clear to have the data sampled when the SPSCCK leaves the idle state (see CPOL) Set to have the data sampled when the SPSCCK returns to idle state (see CPOL)				
1	SPR1	RW	Serial Peripheral Rate (SPR2:SPR1:SPR0) 000: Reserved 001: $F_{CK_SPI}/4$ 010: $F_{CK_SPI}/8$ 011: $F_{CK_SPI}/16$				
0	SPR0	RW	100: $F_{CK_SPI}/32$ 101: $F_{CK_SPI}/64$ 110: $F_{CK_SPI}/128$ 111: Reserved				

Reset Value = 00010100b

Serial Peripheral Status Register (SPSTA)

The Serial Peripheral Status Register contains flags to signal the following conditions:

- Data transfer complete
- Write collision
- Inconsistent logic level on \overline{SS} pin (mode fault error)

Table 86. Serial Peripheral Status and Control Register - SPSTA (C4h)

7	6	5	4	3	2	1	0
SPIF	WCOL	SSERR	MODF	-	-	-	-
Bit Number	Bit Mnemonic	R/W Mode	Description				
7	SPIF	R	Serial Peripheral data transfer flag Clear by hardware to indicate data transfer is in progress or has been approved by a clearing sequence. Set by hardware to indicate that the data transfer has been completed.				
6	WCOL	R	Write Collision flag Cleared by hardware to indicate that no collision has occurred or has been approved by a clearing sequence. Set by hardware to indicate that a collision has been detected.				
5	SSERR	R	Synchronous Serial Slave Error flag Set by hardware when \overline{SS} is modified before the end of a received data. Cleared by disabling the SPI (clearing SPEN bit in SPCON).				
4	MODF	R	Mode Fault Cleared by hardware to indicate that the \overline{SS} pin is at appropriate logic level, or has been approved by a clearing sequence. Set by hardware to indicate that the \overline{SS} pin is at inappropriate logic level.				
3 - 0	-	RW	Reserved The value read from this bit is indeterminate. Do not change these bits.				

Reset Value = 00X0XXXXb



Serial Peripheral DATA Register (SPDAT)

The Serial Peripheral Data Register (Table 87) is a read/write buffer for the receive data register. A write to SPDAT places data directly into the shift register. No transmit buffer is available in this model.

A read of the SPDAT returns the value located in the receive buffer and not the content of the shift register.

Table 87. Serial Peripheral Data Register - SPDAT (C5h)

7	6	5	4	3	2	1	0
R7	R6	R5	R4	R3	R2	R1	R0
Bit Number	Bit Mnemonic	Description					
7-0	R7:0	Receive data bits SPCON, SPSTA and SPDAT registers may be read and written at any time while there is no on-going exchange. However, special care should be taken when writing to them while a transmission is on-going: Do not change SPR2, SPR1 and SPR0 Do not change CPHA and CPOL Do not change MSTR Clearing SPEN would immediately disable the peripheral Writing to the SPDAT will cause an overflow					

Reset Value = XXXX XXXXb

Timers/Counters

The AT8xC5122D implements two general-purpose, 16-bit Timers/Counters. Although they are identified as Timer 0, Timer 1, you can independently configure each to operate in a variety of modes as a Timer or as an event Counter. When operating as a Timer, a Timer/Counter runs for a programmed length of time, then issues an interrupt request. When operating as a Counter, a Timer/Counter counts negative transitions on an external pin. After a preset number of counts, the Counter issues an interrupt request.

The Timer registers and associated control registers are implemented as addressable Special Function Registers (SFRs). Two of the SFRs provide programmable control of the Timers as follows:

- Timer/Counter mode control register (TMOD) and Timer/Counter control register (TCON) control respectively Timer 0 and Timer 1.

The various operating modes of each Timer/Counter are described below.

Timer/Counter Operations

For example, a basic operation is Timer registers THx and TLx (x= 0, 1) connected in cascade to form a 16-bit Timer. Setting the run control bit (TRx) in the TCON register (see Table 88 on page 150) turns the Timer on by allowing the selected input to increment TLx. When TLx overflows, it increments THx and when THx overflows it sets the Timer overflow flag (TFx) in the TCON register. Setting the TRx does not clear the THx and TLx Timer registers. Timer registers can be accessed to obtain the current count or to enter preset values. They can be read at any time but the TRx bit must be cleared to preset their values, otherwise the behavior of the Timer/Counter is unpredictable.

The C/Tx# control bit selects Timer operation or Counter operation by selecting the divided-down system clock or the external pin Tx as the source for the counted signal. The TRx bit must be cleared when changing the operating mode, otherwise the behavior of the Timer/Counter is unpredictable.

For Timer operation (C/Tx# = 0), the Timer register counts the divided-down system clock. The Timer register is incremented once every peripheral cycle.

Exceptions are the Timer 2 Baud Rate and Clock-out modes in which the Timer register is incremented by the system clock divided by two.

For Counter operation (C/Tx# = 1), the Timer register counts the negative transitions on the Tx external input pin. The external input is sampled during every S5P2 state. The Programmer's Guide describes the notation for the states in a peripheral cycle. When the sample is high in one cycle and low in the next one, the Counter is incremented. The new count value appears in the register during the next S3P1 state after the transition has been detected. Since it takes 12 states (24 oscillator periods) to recognize a negative transition, the maximum count rate is 1/24 of the oscillator frequency. There are no restrictions on the duty cycle of the external input signal, but to ensure that a given level is sampled at least once before it changes, it should be held for at least one full peripheral cycle.

Timer 0

Timer 0 functions as either a Timer or an event Counter in four operating modes. Figure 89 through Figure 95 show the logic configuration of each mode.

Timer 0 is controlled by the four lower bits of the TMOD register (see Table 89 on page 151) and bits 0, 1, 4 and 5 of the TCON register (see Table 88 on page 150). The TMOD register selects the method of Timer gating (GATE0), Timer or Counter operation (T/C0#) and the operating mode (M10 and M00). The TCON register provides Timer 0 control functions: overflow flag (TF0), run control bit (TR0), interrupt flag (IE0) and interrupt type control bit (IT0).

For normal Timer operation (GATE0= 0), setting TR0 allows TL0 to be incremented by the selected input. Setting GATE0 and TR0 allows external pin INT0# to control Timer operation.

Timer 0 overflow (count rolls over from all 1s to all 0s) sets the TF0 flag and generates an interrupt request.

It is important to stop the Timer/Counter before changing modes.

Mode 0 (13-bit Timer)

Mode 0 configures Timer 0 as a 13-bit Timer which is set up as an 8-bit Timer (TH0 register) with a modulo-32 prescaler implemented with the lower five bits of the TL0 register (see Figure 89). The upper three bits of the TL0 register are indeterminate and should be ignored. Prescaler overflow increments the TH0 register.

Figure 90 gives the overflow period calculation formula.

Figure 89. Timer/Counter x (x= 0 or 1) in Mode 0

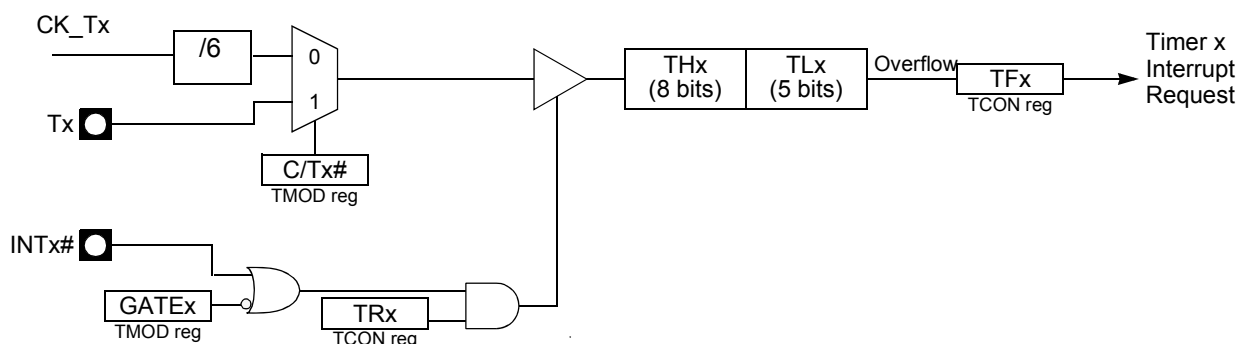

Figure 90. Mode 0 Overflow Period Formula

$$TF_{XPER} = \frac{6 \cdot (16384 - (TH_x, TL_x))}{F_{CK_Tx}}$$

Mode 1 (16-bit Timer)

Mode 1 configures Timer 0 as a 16-bit Timer with the TH0 and TL0 registers connected in a cascade (see Figure 91). The selected input increments the TL0 register.

Figure 92 gives the overflow period calculation formula when in timer mode.

Figure 91. Timer/Counter x (x = 0 or 1) in Mode 1

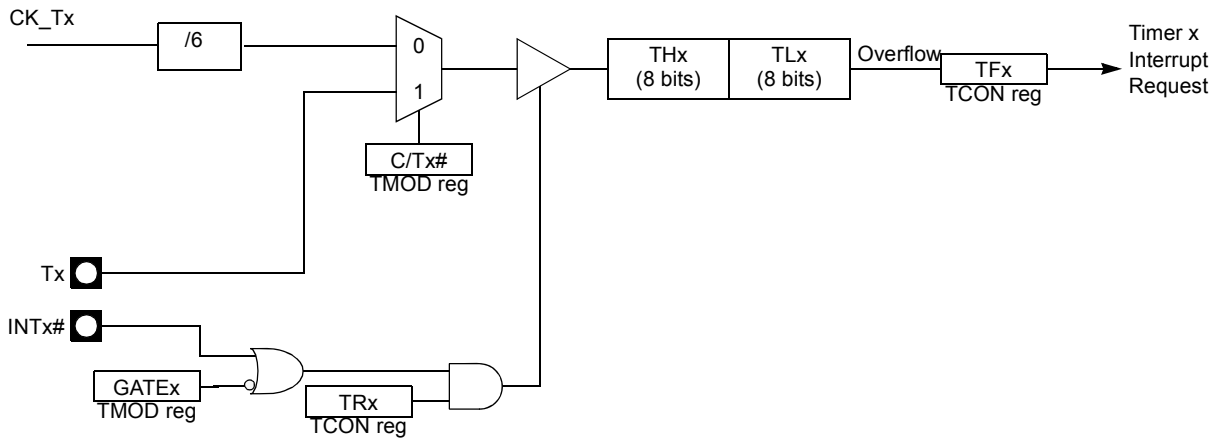

Figure 92. Mode 1 Overflow Period Formula

$$TF_{xPER} = \frac{6 \cdot (65536 - (THx, TLx))}{F_{CK_Tx}}$$

Mode 2 (8-bit Timer with Auto-Reload)

Mode 2 configures Timer 0 as an 8-bit Timer (TL0 register) that automatically reloads from the TH0 register (see Figure 93). TL0 overflow sets the TF0 flag in the TCON register and reloads TL0 with the contents of TH0, which is preset by the software. When the interrupt request is serviced, the hardware clears TF0. The reload leaves TH0 unchanged. The next reload value may be changed at any time by writing it to the TH0 register.

Figure 94 gives the autoreload period calculation formula when in timer mode.

Figure 93. Timer/Counter x (x = 0 or 1) in Mode 2

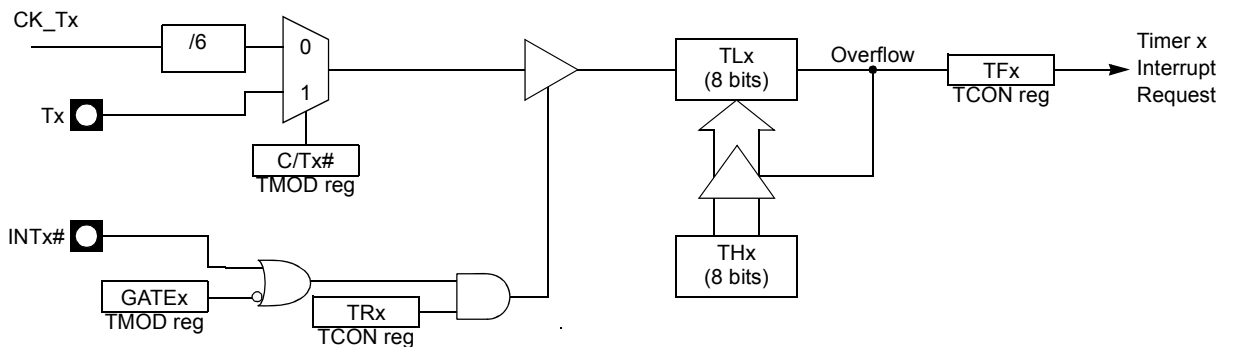

Figure 94. Mode 2 Autoreload Period Formula

$$TF_{xPER} = \frac{6 \cdot (256 - THx)}{F_{CK_Tx}}$$

Mode 3 (Two 8-bit Timers)

Mode 3 configures Timer 0 so that registers TL0 and TH0 operate as 8-bit Timers (see Figure 95). This mode is provided for applications requiring an additional 8-bit Timer or Counter. TL0 uses the Timer 0 control bits C/T0# and GATE0 in the TMOD register, and TR0 and TF0 in the TCON register in the normal manner. TH0 is locked into a Timer function (counting F_{UART}) and takes over use of the Timer 1 interrupt (TF1) and run control (TR1) bits. Thus, operation of Timer 1 is restricted when Timer 0 is in mode 3.

Figure 96 gives the autoreload period calculation formulas for both TF0 and TF1 flags.

Figure 95. Timer/Counter 0 in Mode 3: Two 8-bit Counters

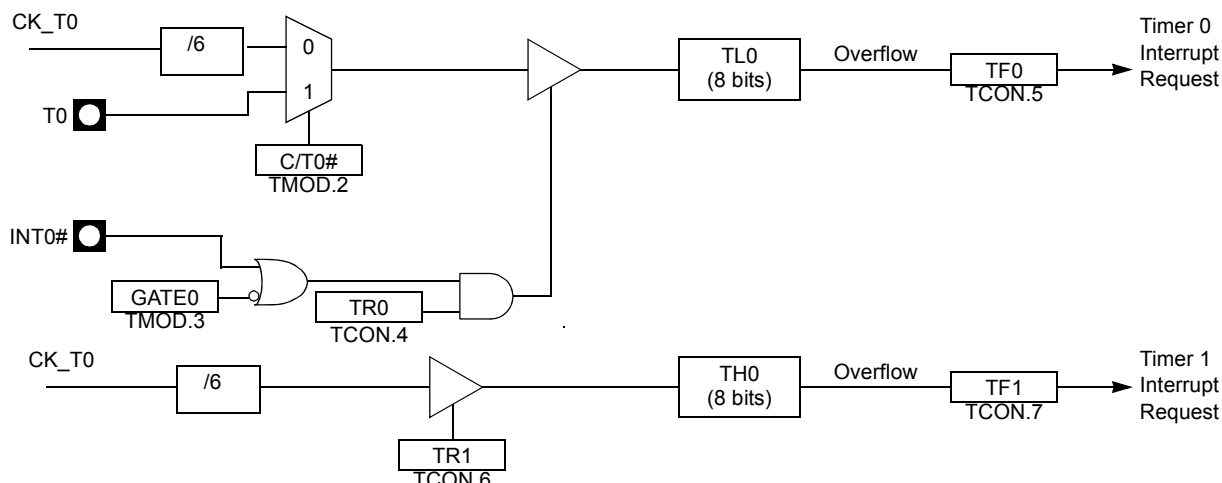

Figure 96. Mode 3 Overflow Period Formula

$$TF0_{PER} = \frac{6 \cdot (256 - TL0)}{F_{CK_T0}} \qquad TF1_{PER} = \frac{6 \cdot (256 - TH0)}{F_{CK_T0}}$$

Timer 1

Timer 1 is identical to Timer 0 except for Mode 3 which is a hold-count mode. The following comments help to understand the differences:

- Timer 1 functions as either a Timer or an event Counter in three operating modes. Figure 89 through Figure 93 show the logical configuration for modes 0, 1, and 2. Mode 3 of Timer 1 is a hold-count mode.
- Timer 1 is controlled by the four high-order bits of the TMOD register (see Table 89 on page 151) and bits 2, 3, 6 and 7 of the TCON register (see Table 88 on page 150). The TMOD register selects the method of Timer gating (GATE1), Timer or Counter operation (C/T1#) and the operating mode (M11 and M01). The TCON register provides Timer 1 control functions: overflow flag (TF1), run control bit (TR1), interrupt flag (IE1) and the interrupt type control bit (IT1).
- Timer 1 can serve as the Baud Rate Generator for the Serial Port. Mode 2 is best suited for this purpose.
- For normal Timer operation (GATE1 = 0), setting TR1 allows TL1 to be incremented by the selected input. Setting GATE1 and TR1 allows external pin INT1# to control Timer operation.
- Timer 1 overflow (count rolls over from all 1s to all 0s) sets the TF1 flag and generates an interrupt request.

- When Timer 0 is in mode 3, it uses Timer 1's overflow flag (TF1) and run control bit (TR1). For this situation, use Timer 1 only for applications that do not require an interrupt (such as a Baud Rate Generator for the Serial Port) and switch Timer 1 in and out of mode 3 to turn it off and on.
- It is important to stop the Timer/Counter before changing modes.

Mode 0 (13-bit Timer)

Mode 0 configures Timer 1 as a 13-bit Timer, which is set up as an 8-bit Timer (TH1 register) with a modulo-32 prescaler implemented with the lower 5 bits of the TL1 register (see Figure 89). The upper 3 bits of TL1 register are ignored. Prescaler overflow increments the TH1 register.

Mode 1 (16-bit Timer)

Mode 1 configures Timer 1 as a 16-bit Timer with TH1 and TL1 registers connected in cascade (see Figure 91). The selected input increments the TL1 register.

Mode 2 (8-bit Timer with Auto-Reload)

Mode 2 configures Timer 1 as an 8-bit Timer (TL1 register) with automatic reload from the TH1 register on overflow (see Figure 93). TL1 overflow sets the TF1 flag in the TCON register and reloads TL1 with the contents of TH1, which is preset by the software. The reload leaves TH1 unchanged.

Mode 3 (Halt)

Placing Timer 1 in mode 3 causes it to halt and hold its count. This can be used to halt Timer 1 when the TR1 run control bit is not available i.e. when Timer 0 is in mode 3.



Registers

Timer/Counter Control Register

Table 88. TCON (S:88h)

7	6	5	4	3	2	1	0
TF1	TR1	TF0	TR0	IE1	IT1	IE0	IT0
Bit Number	Bit Mnemonic	Description					
7	TF1	Timer 1 Overflow flag Cleared by the hardware when processor vectors interrupt routine. Set by the hardware when Timer 1 register overflows.					
6	TR1	Timer 1 Run Control bit Clear to turn off Timer/Counter 1. Set to turn on Timer/Counter 1.					
5	TF0	Timer 0 Overflow flag Cleared by the hardware when processor vectors interrupt routine or by software when the interrupt is disabled Set by the hardware when Timer 0 register overflows.					
4	TR0	Timer 0 Run Control bit Clear to turn off Timer/Counter 0. Set to turn on Timer/Counter 0.					
3	IE1	Interrupt 1 Edge flag Cleared by the hardware when interrupt is processed if edge-triggered (see IT1). Set by the hardware when external interrupt is detected on the INT1# pin.					
2	IT1	Interrupt 1 Type Control bit Clear to select low level active (level triggered) for external interrupt 1 (INT1#). Set to select falling edge active (edge triggered) for external interrupt 1.					
1	IE0	Interrupt 0 Edge flag Cleared by the hardware when interrupt is processed if edge-triggered (see IT0). Set by the hardware when external interrupt is detected on INT0# pin.					
0	IT0	Interrupt 0 Type Control bit Clear to select low level active (level triggered) for external interrupt 0 (INT0#). Set to select falling edge active (edge triggered) for external interrupt 0.					

Reset Value = 0000 0000b

Table 89. Timer/Counter Mode Control Register - TMOD (S:89h)

7	6	5	4	3	2	1	0
GATE1	C/T1#	M11	M01	GATE0	C/T0#	M10	M00

Bit Number	Bit Mnemonic	Description															
7	GATE1	Timer 1 Gating Control bit Clear to enable Timer 1 whenever TR1 bit is set. Set to enable Timer 1 only while INT1# pin is high and TR1 bit is set.															
6	C/T1#	Timer 1 Counter/Timer Select bit Clear for Timer operation: Timer 1 counts the divided-down system clock. Set for Counter operation: Timer 1 counts negative transitions on external pin T1.															
5	M11	Timer 1 Mode Select bits <table style="width: 100%; border-collapse: collapse;"> <tr> <td style="text-align: center;"><u>M11</u></td> <td style="text-align: center;"><u>M01</u></td> <td style="text-align: left;"><u>Operating mode</u></td> </tr> <tr> <td style="text-align: center;">0</td> <td style="text-align: center;">0</td> <td>Mode 0:8-bit Timer/Counter (TH1) with 5-bit prescaler (TL1).</td> </tr> <tr> <td style="text-align: center;">0</td> <td style="text-align: center;">1</td> <td>Mode 1:16-bit Timer/Counter.</td> </tr> <tr> <td style="text-align: center;">1</td> <td style="text-align: center;">0</td> <td>Mode 2:8-bit auto-reload Timer/Counter (TL1) reloaded from TH1 at overflow.</td> </tr> <tr> <td style="text-align: center;">1</td> <td style="text-align: center;">1</td> <td>Mode 3:Timer 1 halted. Retains count.</td> </tr> </table>	<u>M11</u>	<u>M01</u>	<u>Operating mode</u>	0	0	Mode 0:8-bit Timer/Counter (TH1) with 5-bit prescaler (TL1).	0	1	Mode 1:16-bit Timer/Counter.	1	0	Mode 2:8-bit auto-reload Timer/Counter (TL1) reloaded from TH1 at overflow.	1	1	Mode 3:Timer 1 halted. Retains count.
<u>M11</u>	<u>M01</u>		<u>Operating mode</u>														
0	0		Mode 0:8-bit Timer/Counter (TH1) with 5-bit prescaler (TL1).														
0	1		Mode 1:16-bit Timer/Counter.														
1	0	Mode 2:8-bit auto-reload Timer/Counter (TL1) reloaded from TH1 at overflow.															
1	1	Mode 3:Timer 1 halted. Retains count.															
4	M01																
3	GATE0	Timer 0 Gating Control bit Clear to enable Timer 0 whenever TR0 bit is set. Set to enable Timer/Counter 0 only while INTO# pin is high and TR0 bit is set.															
2	C/T0#	Timer 0 Counter/Timer Select bit Clear for Timer operation: Timer 0 counts the divided-down system clock. Set for Counter operation: Timer 0 counts negative transitions on external pin T0.															
1	M10	Timer 0 Mode Select bit <table style="width: 100%; border-collapse: collapse;"> <tr> <td style="text-align: center;"><u>M10</u></td> <td style="text-align: center;"><u>M00</u></td> <td style="text-align: left;"><u>Operating mode</u></td> </tr> <tr> <td style="text-align: center;">0</td> <td style="text-align: center;">0</td> <td>Mode 0:8-bit Timer/Counter (TH0) with 5-bit prescaler (TL0).</td> </tr> <tr> <td style="text-align: center;">0</td> <td style="text-align: center;">1</td> <td>Mode 1:16-bit Timer/Counter.</td> </tr> <tr> <td style="text-align: center;">1</td> <td style="text-align: center;">0</td> <td>Mode 2:8-bit auto-reload Timer/Counter (TL0). Reloaded from TH0 at overflow.</td> </tr> <tr> <td style="text-align: center;">1</td> <td style="text-align: center;">1</td> <td>Mode 3:TL0 is an 8-bit Timer/Counter.</td> </tr> </table> TH0 is an 8-bit Timer using Timer 1's TR0 and TF0 bits.	<u>M10</u>	<u>M00</u>	<u>Operating mode</u>	0	0	Mode 0:8-bit Timer/Counter (TH0) with 5-bit prescaler (TL0).	0	1	Mode 1:16-bit Timer/Counter.	1	0	Mode 2:8-bit auto-reload Timer/Counter (TL0). Reloaded from TH0 at overflow.	1	1	Mode 3:TL0 is an 8-bit Timer/Counter.
<u>M10</u>	<u>M00</u>		<u>Operating mode</u>														
0	0		Mode 0:8-bit Timer/Counter (TH0) with 5-bit prescaler (TL0).														
0	1		Mode 1:16-bit Timer/Counter.														
1	0	Mode 2:8-bit auto-reload Timer/Counter (TL0). Reloaded from TH0 at overflow.															
1	1	Mode 3:TL0 is an 8-bit Timer/Counter.															
0	M00																

Reset Value = 0000 0000b

Table 90. Timer 0 High Byte Register - TH0 (S:8Ch)

7	6	5	4	3	2	1	0
Bit Number	Bit Mnemonic	Description					
7:0		High Byte of Timer 0					

Reset Value = 0000 0000b

Table 91. Timer 0 Low Byte Register - TL0 (S:8Ah)

7	6	5	4	3	2	1	0
Bit Number	Bit Mnemonic	Description					
7:0		Low Byte of Timer 0					

Reset Value = 0000 0000b

Table 92. Timer 1 High Byte Register - TH1 (S:8Dh)

7	6	5	4	3	2	1	0
Bit Number	Bit Mnemonic	Description					
7:0		High Byte of Timer 1					

Reset Value = 0000 0000b

Table 93. Timer 1 Low Byte Register - TL1 (S:8Bh)

7	6	5	4	3	2	1	0
Bit Number	Bit Mnemonic	Description					
7:0		Low Byte of Timer 1					

Reset Value = 0000 0000b

Keyboard Interface

Only for AT8xC5122.

Introduction

The AT83R5122, AT8xC5122/23 implements a keyboard interface allowing the connection of a 8 x n matrix keyboard. It is based on 8 inputs with programmable interrupt capability on both high or low level. These inputs are available as alternate function of P5 and allow to exit from idle and power-down modes.

Description

The keyboard interfaces with the C51 core through 3 special function registers: KBL5, the Keyboard Level Selection register (Table 96 on page 156), KBE, The Keyboard interrupt Enable register (Table 95 on page 155), and KBF, the Keyboard Flag register (Table).

Interrupt

The keyboard inputs are considered as 8 independent interrupt sources sharing the same interrupt vector. An interrupt enable bit (KBD in IE1) allows global enable or disable of the keyboard interrupt (see Figure 97). As detailed in Figure 98 each keyboard input has the capability to detect a programmable level according to KBL5.x bit value. Level detection is then reported in interrupt flags KBF.x that can be masked by software using KBE.x bits.

This structure allows keyboard arrangement from 1 by n to 8 by n matrix and allows usage of P5 inputs for other purpose.

The KBF.x flags are set by hardware when an active level is on input P5.x. They are automatically reset after any read access on KBF. If the content of KBF must be analyzed, the first read instruction must transfer KBF content to another location. The KBF register cannot be written by software.

Figure 97. Keyboard Interface Block Diagram

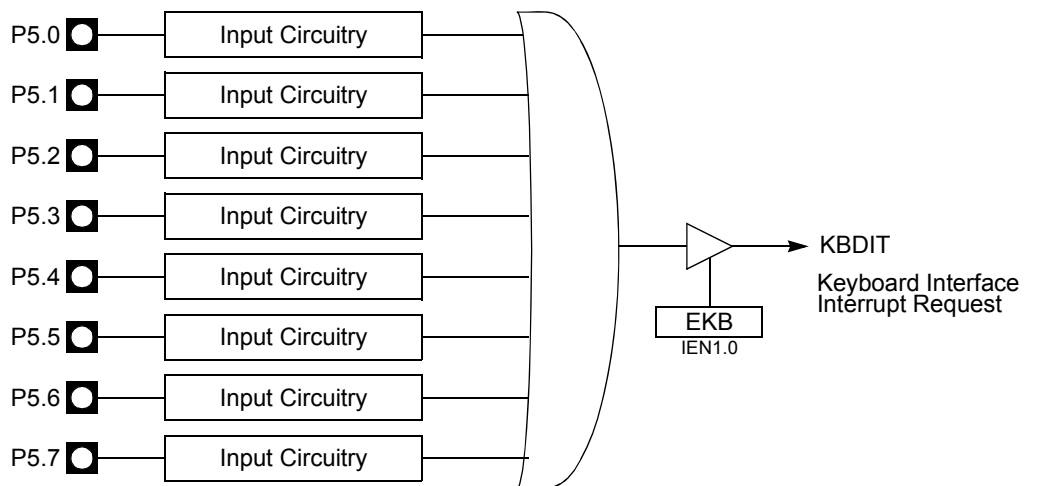
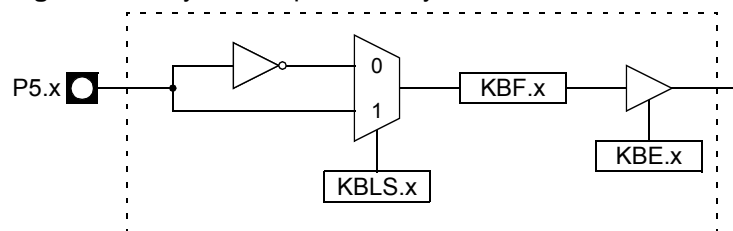

Figure 98. Keyboard Input Circuitry





Power Reduction Mode

P5 inputs allow exit from idle and power-down modes as detailed in Section "Power-Down Mode".

Registers

Table 94. Keyboard Flag Register - KBF (9Eh)

7	6	5	4	3	2	1	0
KBF7	KBF6	KBF5	KBF4	KBF3	KBF2	KBF1	KBF0
Bit Number	Bit Mnemonic	Description					
7	KBF7	Keyboard line 7 flag Set by hardware when the Port line 7 detects a programmed level. It generates a Keyboard interrupt request if the KBE.7 bit in KBE register is set. Cleared by hardware after the read of the KBF register.					
6	KBF6	Keyboard line 6 flag Set by hardware when the Port line 6 detects a programmed level. It generates a Keyboard interrupt request if the KBE.6 bit in KBE register is set. Cleared by hardware after the read of the KBF register.					
5	KBF5	Keyboard line 5 flag Set by hardware when the Port line 5 detects a programmed level. It generates a Keyboard interrupt request if the KBE.5 bit in KBE register is set. Cleared by hardware after the read of the KBF register.					
4	KBF4	Keyboard line 4 flag Set by hardware when the Port line 4 detects a programmed level. It generates a Keyboard interrupt request if the KBE.4 bit in KBE register is set. Cleared by hardware after the read of the KBF register.					
3	KBF3	Keyboard line 3 flag Set by hardware when the Port line 3 detects a programmed level. It generates a Keyboard interrupt request if the KBE.3 bit in KBE register is set. Cleared by hardware after the read of the KBF register.					
2	KBF2	Keyboard line 2 flag Set by hardware when the Port line 2 detects a programmed level. It generates a Keyboard interrupt request if the KBE.2 bit in KBE register is set. Cleared by hardware after the read of the KBF register.					
1	KBF1	Keyboard line 1 flag Set by hardware when the Port line 1 detects a programmed level. It generates a Keyboard interrupt request if the KBE.1 bit in KBE register is set. Cleared by hardware after the read of the KBF register.					
0	KBF0	Keyboard line 0 flag Set by hardware when the Port line 0 detects a programmed level. It generates a Keyboard interrupt request if the KBE.0 bit in KBE register is set. Cleared by hardware after the read of the KBF register.					

Reset Value = 0000 0000b

Table 95. Keyboard Input Enable Register - KBE (9Dh)

7	6	5	4	3	2	1	0
KBE7	KBE6	KBE5	KBE4	KBE3	KBE2	KBE1	KBE0
Bit Number	Bit Mnemonic	Description					
7	KBE7	Keyboard line 7 Enable bit Cleared to enable standard I/O pin. Set to enable KBF.7 bit in KBF register to generate an interrupt request.					
6	KBE6	Keyboard line 6 Enable bit Cleared to enable standard I/O pin. Set to enable KBF.6 bit in KBF register to generate an interrupt request.					
5	KBE5	Keyboard line 5 Enable bit Cleared to enable standard I/O pin. Set to enable KBF.5 bit in KBF register to generate an interrupt request.					
4	KBE4	Keyboard line 4 Enable bit Cleared to enable standard I/O pin. Set to enable KBF.4 bit in KBF register to generate an interrupt request.					
3	KBE3	Keyboard line 3 Enable bit Cleared to enable standard I/O pin. Set to enable KBF.3 bit in KBF register to generate an interrupt request.					
2	KBE2	Keyboard line 2 Enable bit Cleared to enable standard I/O pin. Set to enable KBF.2 bit in KBF register to generate an interrupt request.					
1	KBE1	Keyboard line 1 Enable bit Cleared to enable standard I/O pin. Set to enable KBF.1 bit in KBF register to generate an interrupt request.					
0	KBE0	Keyboard line 0 Enable bit Cleared to enable standard I/O pin. Set to enable KBF.0 bit in KBF register to generate an interrupt request.					

Reset Value = 0000 0000b



Table 96. Keyboard Level Selector Register - KBL5 (9Ch)

7	6	5	4	3	2	1	0
KBLS7	KBLS6	KBLS5	KBLS4	KBLS3	KBLS2	KBLS1	KBLS0
Bit Number	Bit Mnemonic	Description					
7	KBLS7	Keyboard line 7 Level Selection bit Cleared to enable a low level detection on Port line 7. Set to enable a high level detection on Port line 7.					
6	KBLS6	Keyboard line 6 Level Selection bit Cleared to enable a low level detection on Port line 6. Set to enable a high level detection on Port line 6.					
5	KBLS5	Keyboard line 5 Level Selection bit Cleared to enable a low level detection on Port line 5. Set to enable a high level detection on Port line 5.					
4	KBLS4	Keyboard line 4 Level Selection bit Cleared to enable a low level detection on Port line 4. Set to enable a high level detection on Port line 4.					
3	KBLS3	Keyboard line 3 Level Selection bit Cleared to enable a low level detection on Port line 3. Set to enable a high level detection on Port line 3.					
2	KBLS2	Keyboard line 2 Level Selection bit Cleared to enable a low level detection on Port line 2. Set to enable a high level detection on Port line 2.					
1	KBLS1	Keyboard line 1 Level Selection bit Cleared to enable a low level detection on Port line 1. Set to enable a high level detection on Port line 1.					
0	KBLS0	Keyboard line 0 Level Selection bit Cleared to enable a low level detection on Port line 0. Set to enable a high level detection on Port line 0.					

Reset Value = 0000 0000b

Interrupt System

Introduction

The AT83R5122, AT8xC5122/23 implements an interrupt controller with 15 inputs but only 9 are used for :

- two external interrupts ($\overline{\text{INT0}}$ and $\overline{\text{INT1}}$)
- two timer interrupts (timers 0, 1),
- the UART interface
- the SPI interface
- the keyboard interface
- the USB interface
- the Smart Card Interface.

Interrupt System Description

Each of the interrupt sources can be individually enabled or disabled by setting or clearing a bit in the Interrupt Enable registers (Table 98 on page 160 and Table 99 on page 161). These registers also contain a global disable bit, which must be cleared to disable all interrupts at once.

Each interrupt source can also be individually programmed to one out of four priority levels by setting or clearing a bit in the Interrupt Priority Low registers (Table 101 on page 162 and Table 103 on page 164) and in the Interrupt Priority High register (Table 102 on page 163 and Table 105 on page 166) shows the bit values and priority levels associated with each combination.

A low-priority interrupt can be interrupted by a high priority interrupt, but not by another low-priority interrupt. A high-priority interrupt can't be interrupted by any other interrupt source.

If two interrupt requests of different priority levels are received simultaneously, the request of higher priority level is serviced. If interrupt requests of the same priority level are received simultaneously, an internal polling sequence determines which request is serviced first. Thus within each priority level there is a second priority structure determined by the polling sequence.

Table 97. Priority Level Bit Values

IPH.x	IPL.x	Interrupt Level Priority
0	0	0 (Lowest)
0	1	1
1	0	2
1	1	3 (Highest)

Figure 99. Interrupt Control System

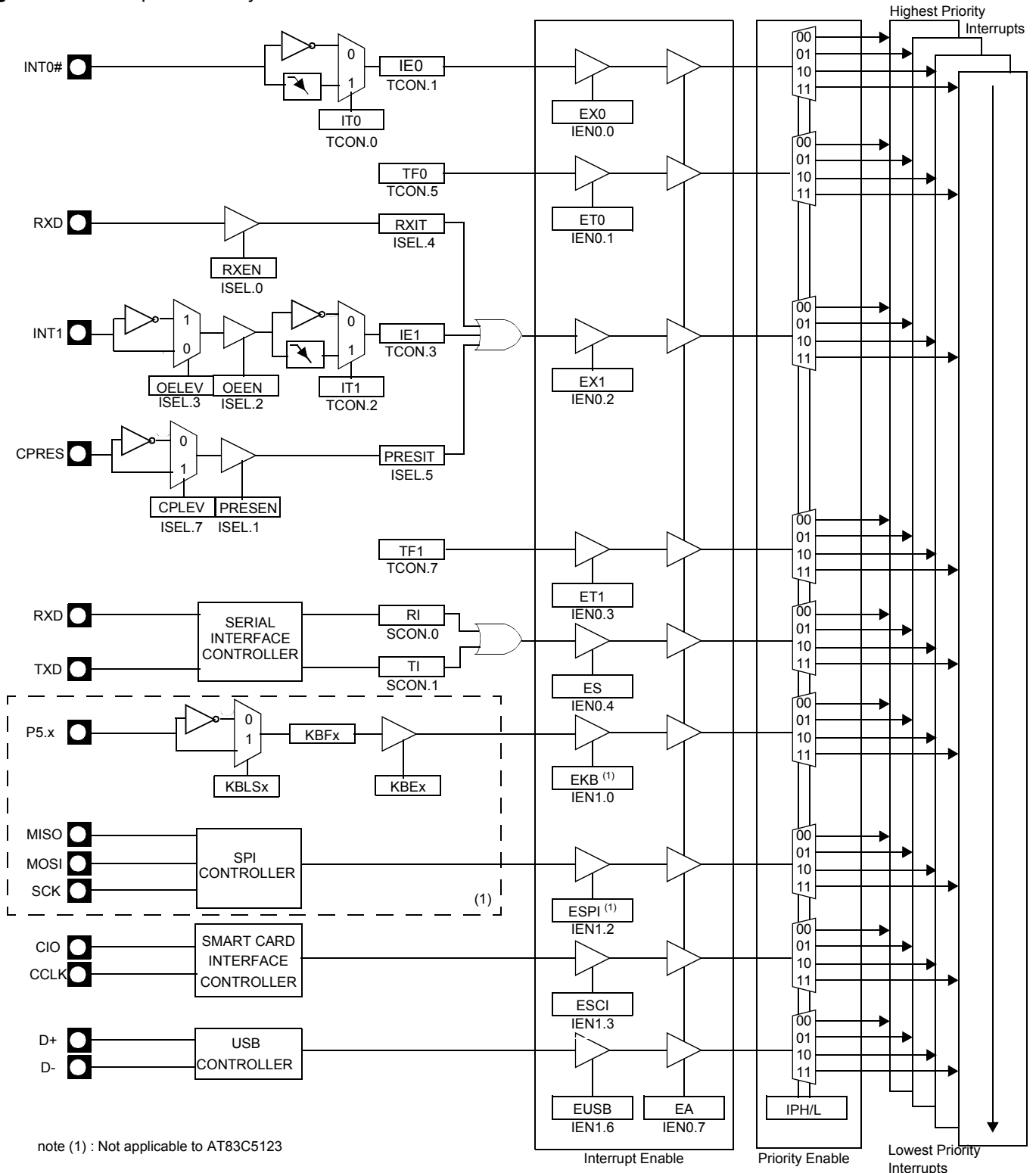

$\overline{\text{INT1}}$ Interrupt Vector

The $\overline{\text{INT1}}$ interrupt is multiplexed with the following three inputs:

- INT1 : Standard 8051 interrupt input
- RXD : Received data on UART
- CPRES: Insertion or remove of the main card

The setting configurations for each input is detailed below.

$\overline{\text{INT1}}$ Input

This interrupt input is active under the following conditions :

- It must be enabled by OEEN Bit (ISEL Register)
- It can be active on a level or falling edge following IT1 Bit (TCON Register) status
- If level triggering selection is set, the active level 0 or 1 can be selected with OELEV Bit (ISEL Register)

The Bit IE1 (TCON Register) is set by hardware when external interrupt detected. It is cleared when interrupt is processed.

RXD Input

A second vector interrupt input is the reception of a character. UART Rx input can generate an interrupt if enabled with Bit RXEN (ISEL.0). The global enable bits EX1 and EA must also be set.

Then, the Bit RXIT (ISEL Register) is set by hardware when a low level is detected on P3.0/RXD input.

CPRES Input

The third input is the detection of a level change on CPRES input (P1.2). This input can generate an interrupt if enabled with PRESEN (ISEL.1) , EX1 (IE0.2) and EA (IE0.7) Bits.

This detection is done according to the level selected with Bit CPLEV (ISEL.7).

Then the Bit PRESIT (ISEL.5) is set by hardware when the triggering conditions are met. This Bit must be cleared by software.

Registers

Table 98. Interrupt Enable Register 0 - IEN0 (A8h)

7	6	5	4	3	2	1	0
EA	-	-	ES	ET1	EX1	ET0	EX0

Bit Number	Bit Mnemonic	Description
7	EA	Enable All interrupt bit Cleared to disable all interrupts. Set to enable all interrupts.
6 - 5	-	Reserved The value read from this bit is indeterminate. Do not change these bits.
4	ES	Serial port Enable bit Cleared to disable serial port interrupt. Set to enable serial port interrupt.
3	ET1	Timer 1 overflow interrupt Enable bit Cleared to disable timer 1 overflow interrupt. Set to enable timer 1 overflow interrupt.
2	EX1	External interrupt 1 Enable bit Cleared to disable external interrupt 1. Set to enable external interrupt 1.
1	ET0	Timer 0 overflow interrupt Enable bit Cleared to disable timer 0 overflow interrupt. Set to enable timer 0 overflow interrupt.
0	EX0	External interrupt 0 Enable bit Cleared to disable external interrupt 0. Set to enable external interrupt 0.

Reset Value = 0000 0000b (Bit addressable)

Table 99. Interrupt Enable Register 1 - IEN1 (B1h) for AT8xC5122

7	6	5	4	3	2	1	0
-	EUSB	-	-	ESCI	ESPI	-	EKB

Bit Number	Bit Mnemonic	Description
7	-	Reserved The value read from this bit is indeterminate. Do not change this bit.
6	EUSB	USB Interrupt Enable bit Cleared to disable USB interrupt . Set to enable USB interrupt.
5 - 4	-	Reserved The value read from this bit is indeterminate. Do not change these bits.
3	ESCI	SCI interrupt Enable bit Cleared to disable SCI interrupt . Set to enable SCI interrupt.
2	ESPI	SPI interrupt Enable bit Cleared to disable SPI interrupt . Set to enable SPI interrupt.
1	-	Reserved The value read from this bit is indeterminate. Do not change this bit.
0	EKB	Keyboard interrupt Enable bit Cleared to disable keyboard interrupt . Set to enable keyboard interrupt.

Reset Value = X0XX 00X0b (Bit addressable)



Table 100. Interrupt Enable Register 1 - IEN1 (B1h) for AT83C5123

7	6	5	4	3	2	1	0
-	EUSB	-	-	ESCI		-	

Bit Number	Bit Mnemonic	Description
7	-	Reserved The value read from this bit is indeterminate. Do not change this bit.
6	EUSB	USB Interrupt Enable bit Cleared to disable USB interrupt . Set to enable USB interrupt.
5 - 4	-	Reserved The value read from this bit is indeterminate. Do not change these bits.
3	ESCI	SCI interrupt Enable bit Cleared to disable SCIinterrupt . Set to enable SCI interrupt.
2		Reserved The value read from this bit is indeterminate. Do not change this bit.
1	-	Reserved The value read from this bit is indeterminate. Do not change this bit.
0		Reserved The value read from this bit is indeterminate. Do not change this bit.

Reset Value = X0XX 0XXXb (Bit addressable)

Table 101. Interrupt Priority Low Register 0 - IPL0 (B8h)

7	6	5	4	3	2	1	0
-	-	-	PSL	PT1L	PX1L	PT0L	PX0L

Bit Number	Bit Mnemonic	Description
7 - 5	-	Reserved The value read from this bit is indeterminate. Do not change these bits.
4	PSL	Serial port Priority bit Refer to PSH for priority level.
3	PT1L	Timer 1 overflow interrupt Priority bit Refer to PT1H for priority level.
2	PX1L	External interrupt 1 Priority bit Refer to PX1H for priority level.
1	PT0L	Timer 0 overflow interrupt Priority bit Refer to PT0H for priority level.
0	PX0L	External interrupt 0 Priority bit Refer to PX0H for priority level.

Reset Value = X000 0000b (Bit addressable)

Table 102. Interrupt Priority High Register 0 - IPH0 (B7h)

	7	6	5	4	3	2	1	0
	-	-	-	PSH	PT1H	PX1H	PT0H	PX0H

Bit Number	Bit Mnemonic	Description															
7 - 5	-	Reserved The value read from this bit is indeterminate. Do not change these bits.															
4	PSH	Serial port Priority High bit <table style="width: 100%; border-collapse: collapse;"> <tr> <td style="text-align: left;"><u>PSH</u></td> <td style="text-align: left;"><u>PSL</u></td> <td style="text-align: left;"><u>Priority Level</u></td> </tr> <tr> <td>0</td> <td>0</td> <td>Lowest</td> </tr> <tr> <td>0</td> <td>1</td> <td></td> </tr> <tr> <td>1</td> <td>0</td> <td></td> </tr> <tr> <td>1</td> <td>1</td> <td>Highest</td> </tr> </table>	<u>PSH</u>	<u>PSL</u>	<u>Priority Level</u>	0	0	Lowest	0	1		1	0		1	1	Highest
<u>PSH</u>	<u>PSL</u>	<u>Priority Level</u>															
0	0	Lowest															
0	1																
1	0																
1	1	Highest															
3	PT1H	Timer 1 overflow interrupt Priority High bit <table style="width: 100%; border-collapse: collapse;"> <tr> <td style="text-align: left;"><u>PT1H</u></td> <td style="text-align: left;"><u>PT1L</u></td> <td style="text-align: left;"><u>Priority Level</u></td> </tr> <tr> <td>0</td> <td>0</td> <td>Lowest</td> </tr> <tr> <td>0</td> <td>1</td> <td></td> </tr> <tr> <td>1</td> <td>0</td> <td></td> </tr> <tr> <td>1</td> <td>1</td> <td>Highest</td> </tr> </table>	<u>PT1H</u>	<u>PT1L</u>	<u>Priority Level</u>	0	0	Lowest	0	1		1	0		1	1	Highest
<u>PT1H</u>	<u>PT1L</u>	<u>Priority Level</u>															
0	0	Lowest															
0	1																
1	0																
1	1	Highest															
2	PX1H	External interrupt 1 Priority High bit <table style="width: 100%; border-collapse: collapse;"> <tr> <td style="text-align: left;"><u>PX1H</u></td> <td style="text-align: left;"><u>PX1L</u></td> <td style="text-align: left;"><u>Priority Level</u></td> </tr> <tr> <td>0</td> <td>0</td> <td>Lowest</td> </tr> <tr> <td>0</td> <td>1</td> <td></td> </tr> <tr> <td>1</td> <td>0</td> <td></td> </tr> <tr> <td>1</td> <td>1</td> <td>Highest</td> </tr> </table>	<u>PX1H</u>	<u>PX1L</u>	<u>Priority Level</u>	0	0	Lowest	0	1		1	0		1	1	Highest
<u>PX1H</u>	<u>PX1L</u>	<u>Priority Level</u>															
0	0	Lowest															
0	1																
1	0																
1	1	Highest															
1	PT0H	Timer 0 overflow interrupt Priority High bit <table style="width: 100%; border-collapse: collapse;"> <tr> <td style="text-align: left;"><u>PT0H</u></td> <td style="text-align: left;"><u>PT0L</u></td> <td style="text-align: left;"><u>Priority Level</u></td> </tr> <tr> <td>0</td> <td>0</td> <td>Lowest</td> </tr> <tr> <td>0</td> <td>1</td> <td></td> </tr> <tr> <td>1</td> <td>0</td> <td></td> </tr> <tr> <td>1</td> <td>1</td> <td>Highest</td> </tr> </table>	<u>PT0H</u>	<u>PT0L</u>	<u>Priority Level</u>	0	0	Lowest	0	1		1	0		1	1	Highest
<u>PT0H</u>	<u>PT0L</u>	<u>Priority Level</u>															
0	0	Lowest															
0	1																
1	0																
1	1	Highest															
0	PX0H	External interrupt 0 Priority High bit <table style="width: 100%; border-collapse: collapse;"> <tr> <td style="text-align: left;"><u>PX0H</u></td> <td style="text-align: left;"><u>PX0L</u></td> <td style="text-align: left;"><u>Priority Level</u></td> </tr> <tr> <td>0</td> <td>0</td> <td>Lowest</td> </tr> <tr> <td>0</td> <td>1</td> <td></td> </tr> <tr> <td>1</td> <td>0</td> <td></td> </tr> <tr> <td>1</td> <td>1</td> <td>Highest</td> </tr> </table>	<u>PX0H</u>	<u>PX0L</u>	<u>Priority Level</u>	0	0	Lowest	0	1		1	0		1	1	Highest
<u>PX0H</u>	<u>PX0L</u>	<u>Priority Level</u>															
0	0	Lowest															
0	1																
1	0																
1	1	Highest															

Reset Value = X000 0000b (Not bit addressable)



Table 103. Interrupt Priority Low Register 1 - IPL1 (B2h) for AT8xC5122

7	6	5	4	3	2	1	0
-	PUSBL	-	-	PSCIL	PSPIL	-	PKBDL

Bit Number	Bit Mnemonic	Description
7	-	Reserved The value read from this bit is indeterminate. Do not change this bit.
6	PUSBL	USB Interrupt Priority bit Refer to PUSBH for priority level.
5 - 4	-	Reserved The value read from this bit is indeterminate. Do not change these bits.
3	PSCIL	SCI Interrupt Priority bit Refer to PSPIH for priority level.
2	PSPIL	SPI Interrupt Priority bit Refer to PSPIH for priority level.
1	-	Reserved The value read from this bit is indeterminate. Do not change this bit.
0	PKBL	Keyboard Interrupt Priority bit Refer to PKBDH for priority level.

Reset Value = X00X 00X0b (Bit addressable)

Table 104. Interrupt Priority Low Register 1 - IPL1 (B2h) for AT83C5123

7	6	5	4	3	2	1	0
-	PUSBL	-	-	PSCIL			
Bit Number	Bit Mnemonic	Description					
7	-	Reserved The value read from this bit is indeterminate. Do not change this bit.					
6	PUSBL	USB Interrupt Priority bit Refer to PUSBH for priority level.					
5 - 4	-	Reserved The value read from this bit is indeterminate. Do not change these bits.					
3	PSCIL	SCI Interrupt Priority bit Refer to PSPIH for priority level.					
2		Reserved The value read from this bit is indeterminate. Do not change this bit.					
1		Reserved The value read from this bit is indeterminate. Do not change this bit.					
0		Reserved The value read from this bit is indeterminate. Do not change this bit.					

Reset Value = X0XX 0XXXb (Bit addressable)



Table 105. Interrupt Priority High Register 1 - IPH1 (B3h) for AT8xC5122

7	6	5	4	3	2	1	0															
-	PUSBH	-	-	PSCIH		-																
Bit Number	Bit Mnemonic	Description																				
7	-	Reserved The value read from this bit is indeterminate. Do not change this bit.																				
6	PUSBH	USB Interrupt Priority High bit <table border="1" style="width: 100%; border-collapse: collapse;"> <thead> <tr> <th style="text-align: left;"><u>PUSBH</u></th> <th style="text-align: left;"><u>PUSBL</u></th> <th style="text-align: left;"><u>Priority Level</u></th> </tr> </thead> <tbody> <tr> <td>0</td> <td>0</td> <td>Lowest</td> </tr> <tr> <td>0</td> <td>1</td> <td></td> </tr> <tr> <td>1</td> <td>0</td> <td></td> </tr> <tr> <td>1</td> <td>1</td> <td>Highest</td> </tr> </tbody> </table>						<u>PUSBH</u>	<u>PUSBL</u>	<u>Priority Level</u>	0	0	Lowest	0	1		1	0		1	1	Highest
<u>PUSBH</u>	<u>PUSBL</u>	<u>Priority Level</u>																				
0	0	Lowest																				
0	1																					
1	0																					
1	1	Highest																				
5-4	-	Reserved The value read from this bit is indeterminate. Do not change these bits.																				
3	PSCIH	SCI Interrupt Priority High bit <table border="1" style="width: 100%; border-collapse: collapse;"> <thead> <tr> <th style="text-align: left;"><u>PSCIH</u></th> <th style="text-align: left;"><u>PSCIL</u></th> <th style="text-align: left;"><u>Priority Level</u></th> </tr> </thead> <tbody> <tr> <td>0</td> <td>0</td> <td>Lowest</td> </tr> <tr> <td>0</td> <td>1</td> <td></td> </tr> <tr> <td>1</td> <td>0</td> <td></td> </tr> <tr> <td>1</td> <td>1</td> <td>Highest</td> </tr> </tbody> </table>						<u>PSCIH</u>	<u>PSCIL</u>	<u>Priority Level</u>	0	0	Lowest	0	1		1	0		1	1	Highest
<u>PSCIH</u>	<u>PSCIL</u>	<u>Priority Level</u>																				
0	0	Lowest																				
0	1																					
1	0																					
1	1	Highest																				
2	PSPIH	SPI Interrupt Priority High bit <table border="1" style="width: 100%; border-collapse: collapse;"> <thead> <tr> <th style="text-align: left;"><u>PSPIH</u></th> <th style="text-align: left;"><u>PSPIL</u></th> <th style="text-align: left;"><u>Priority Level</u></th> </tr> </thead> <tbody> <tr> <td>0</td> <td>0</td> <td>Lowest</td> </tr> <tr> <td>0</td> <td>1</td> <td></td> </tr> <tr> <td>1</td> <td>0</td> <td></td> </tr> <tr> <td>1</td> <td>1</td> <td>Highest</td> </tr> </tbody> </table>						<u>PSPIH</u>	<u>PSPIL</u>	<u>Priority Level</u>	0	0	Lowest	0	1		1	0		1	1	Highest
<u>PSPIH</u>	<u>PSPIL</u>	<u>Priority Level</u>																				
0	0	Lowest																				
0	1																					
1	0																					
1	1	Highest																				
1	-	Reserved The value read from this bit is indeterminate. Do not change this bit.																				
0	PKBH	Keyboard Interrupt Priority High bit <table border="1" style="width: 100%; border-collapse: collapse;"> <thead> <tr> <th style="text-align: left;"><u>PKBDH</u></th> <th style="text-align: left;"><u>PKBDL</u></th> <th style="text-align: left;"><u>Priority Level</u></th> </tr> </thead> <tbody> <tr> <td>0</td> <td>0</td> <td>Lowest</td> </tr> <tr> <td>0</td> <td>1</td> <td></td> </tr> <tr> <td>1</td> <td>0</td> <td></td> </tr> <tr> <td>1</td> <td>1</td> <td>Highest</td> </tr> </tbody> </table>						<u>PKBDH</u>	<u>PKBDL</u>	<u>Priority Level</u>	0	0	Lowest	0	1		1	0		1	1	Highest
<u>PKBDH</u>	<u>PKBDL</u>	<u>Priority Level</u>																				
0	0	Lowest																				
0	1																					
1	0																					
1	1	Highest																				

Reset Value = XXXX X000b (Not bit addressable)

Table 106. Interrupt Priority High Register 1 - IPH1 (B3h) for AT83C5123

7	6	5	4	3	2	1	0
-	PUSBH	-	-	PSCIH	-	-	-

Bit Number	Bit Mnemonic	Description															
7	-	Reserved The value read from this bit is indeterminate. Do not change this bit.															
6	PUSBH	USB Interrupt Priority High bit <table style="width: 100%; border-collapse: collapse;"> <tr> <td style="border-bottom: 1px solid black; width: 15%;"><u>PUSBH</u></td> <td style="border-bottom: 1px solid black; width: 15%;"><u>PUSBL</u></td> <td style="border-bottom: 1px solid black; width: 15%;"><u>Priority Level</u></td> </tr> <tr> <td>0</td> <td>0</td> <td>Lowest</td> </tr> <tr> <td>0</td> <td>1</td> <td></td> </tr> <tr> <td>1</td> <td>0</td> <td></td> </tr> <tr> <td>1</td> <td>1</td> <td>Highest</td> </tr> </table>	<u>PUSBH</u>	<u>PUSBL</u>	<u>Priority Level</u>	0	0	Lowest	0	1		1	0		1	1	Highest
<u>PUSBH</u>	<u>PUSBL</u>	<u>Priority Level</u>															
0	0	Lowest															
0	1																
1	0																
1	1	Highest															
5-4	-	Reserved The value read from this bit is indeterminate. Do not change these bits.															
3	PSCIH	SCI Interrupt Priority High bit <table style="width: 100%; border-collapse: collapse;"> <tr> <td style="border-bottom: 1px solid black; width: 15%;"><u>PSCIH</u></td> <td style="border-bottom: 1px solid black; width: 15%;"><u>PSCIL</u></td> <td style="border-bottom: 1px solid black; width: 15%;"><u>Priority Level</u></td> </tr> <tr> <td>0</td> <td>0</td> <td>Lowest</td> </tr> <tr> <td>0</td> <td>1</td> <td></td> </tr> <tr> <td>1</td> <td>0</td> <td></td> </tr> <tr> <td>1</td> <td>1</td> <td>Highest</td> </tr> </table>	<u>PSCIH</u>	<u>PSCIL</u>	<u>Priority Level</u>	0	0	Lowest	0	1		1	0		1	1	Highest
<u>PSCIH</u>	<u>PSCIL</u>	<u>Priority Level</u>															
0	0	Lowest															
0	1																
1	0																
1	1	Highest															
2		Reserved The value read from this bit is indeterminate. Do not change these bits.															
1	-	Reserved The value read from this bit is indeterminate. Do not change this bit.															
0		Reserved The value read from this bit is indeterminate. Do not change these bits.															

Reset Value = X0XX 0XXXb (Not bit addressable)

Table 107. Interrupt Enable Register - ISEL (S:A1h)

	7	6	5	4	3	2	1	0
	CPLEV	-	PRESIT	RXIT	OELEV	OEEN	PRESEN	RXEN

Bit Number	Bit Mnemonic	Description
7	CPLEV	<p>Card presence detection level This bit indicates which CPRES level will bring about an interrupt Set this bit to indicate that Card Presence IT will appear if CPRES is at high level. Clear this bit to indicate that Card Presence IT will appear if CPRES is at low level.</p>
6	-	<p>Reserved The value read from this bit is indeterminate. Do not change this bit.</p>
5	PRESIT	<p>Card presence detection interrupt flag Set by hardware Must be cleared by software</p>
4	RXIT	<p>Received data interrupt flag Set by hardware Must be cleared by software</p>
3	OELEV	<p>INT1 signal active level Set this bit to indicate that high level is active. Clear this bit to indicate that low level is active.</p>
2	OEEN	<p>INT1 Interrupt Disable bit Clear to disable INT1 interrupt Set to enable INT1 interrupt</p>
1	PRESEN	<p>Card presence detection Interrupt Enable bit Clear to disable the card presence detection interrupt coming from SCIB. Set to enable the card presence detection interrupt coming from SCIB.</p>
0	RXEN	<p>Received data Interrupt Enable bit Clear to disable the RxD interrupt. Set to enable the RxD interrupt (a minimal bit width of 100 μs is required to wake up from power-down) .</p>

Reset Value = 0000 0000b

Interrupt Sources and Vectors

Table 108. Interrupt Vectors

Interrupt Source	Polling Priority at Same Level	Vector Address
Reset	0 (Highest Priority)	C:0000h
INT0	1	C:0003h
Timer 0	2	C:000Bh
INT1	3	C:0013h
Timer 1	4	C:001Bh
UART	6	C:0023h
Reserved	7	C:002Bh
Reserved	5	C:0033h
Keyboard Controller ⁽¹⁾	8	C:003Bh
Reserved	9	C:0043h
SPI Controller ⁽¹⁾	10	C:004Bh
Smart Card Controller	11	C:0053h
Reserved	12	C:005Bh
Reserved	13	C:0063h
USB Controller	14	C:006Bh
Reserved	15 (Lowest Priority)	C:0073h

Note: 1. Only for AT8xC5122

Microcontroller Reset

Introduction

The internal reset is used to start up (cold reset) or to re-start (warm reset) the microcontroller activity. When the reset is applied (active state), all internal registers are initialized so that the microcontroller starts from a known and clean state for the program always runs as expected.

The reset is released (inactive state) when the following conditions are internally met :

- The power supply has reached a minimum level which guarantees that the microcontroller works properly
- The on-chip oscillator has reached a minimum oscillation level which ensures a good noise to signal ratio and a correct internal duty cycle
- the active state duration is at least two machine cycles.

If one of the above conditions is not met the microcontroller is not correctly reset and might not work properly.

The internal reset comes from four different sources :

- Reset pin
- Power On Reset (POR)
- Power Fail Detector (PFD)
- Hardware Watch-Dog Timer (WDT)

Figure 100. Reset block diagram

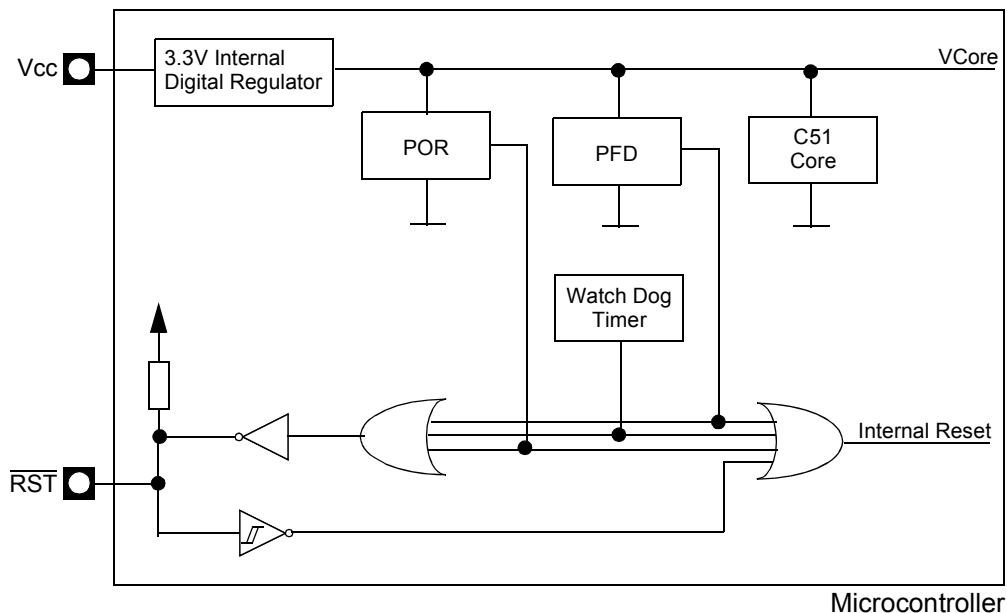

Power On Reset (POR)

The role of the POR is to monitor the power supply rise of the microcontroller core and release the internal reset only when the internal voltage exceeds the VPFDP threshold from which the microcontroller core is stable (see Figure 101). This feature replaces the external reset function and therefore avoid the use of external components on the reset pin.

Power Fail Detector (PFD)

The role of the PFD is to monitor the power supply falls during a steady state condition in order to suspend the microcontroller and peripherals activity as soon as the power supply drops below the VPFDM threshold from which the microcontroller's core might become instable (see Figure 101). The PFD suspends the microcontroller's activity by holding the microcontroller under a reset state to avoid an unpredictable behaviour.

A filter prevents the system from resetting when glitches lower than 50 ns duration are carried on Vcore. See Figure 101 and Figure 102 on page 172.

Figure 101. Static behaviour of POR and PFD

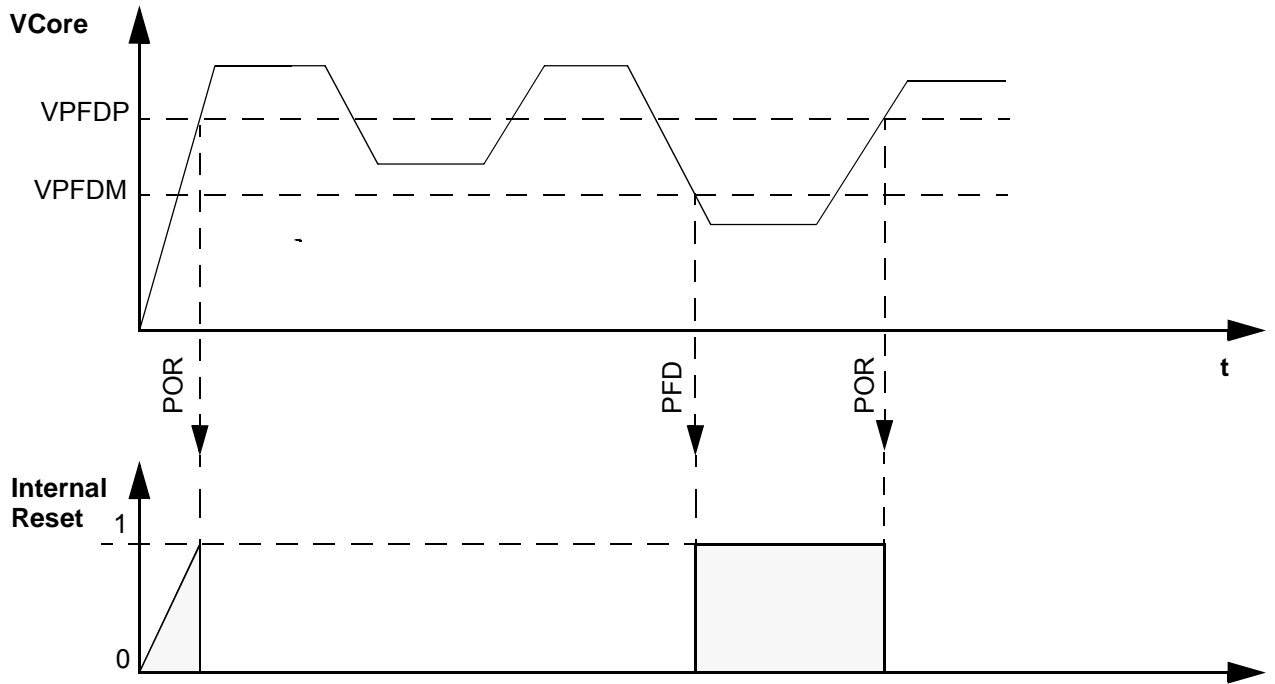
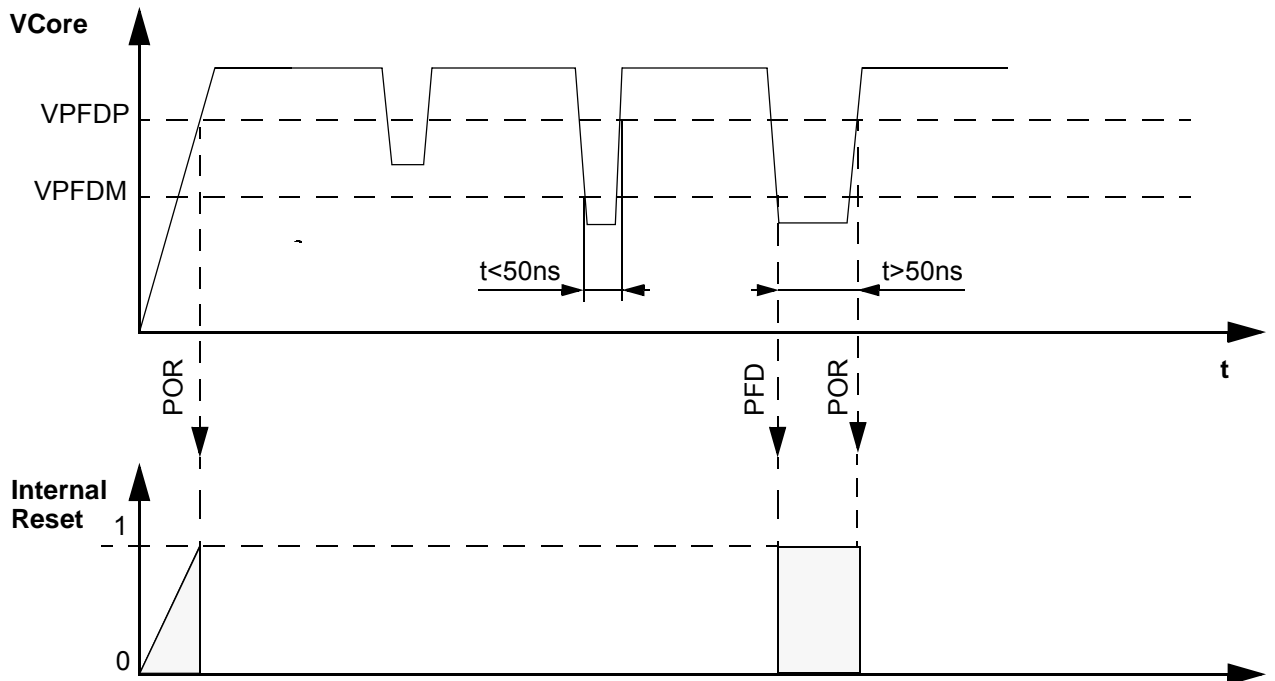

Figure 102. Dynamic behaviour of POR and PFD



Reset pin

As explained in the POR section there is no need to use the reset pin as the internal reset function at power up is ensured by the POR. Anyway, if some applications requires a long reset, a reset controlled by the user or a reset controlled by external supervisor device, the use of the reset pin is necessary.

Long Reset

As the pad integrates an internal pull-up of 10K, only an external capacitor of at least 10 μF is required to have an impact on the reset duration.

Figure 103. Long Reset

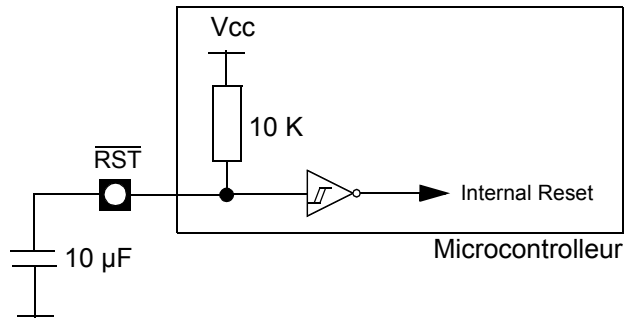

Reset Controlled by the User

The external capacitor is not needed if no long reset is required.

Figure 104. Reset Controlled by the User

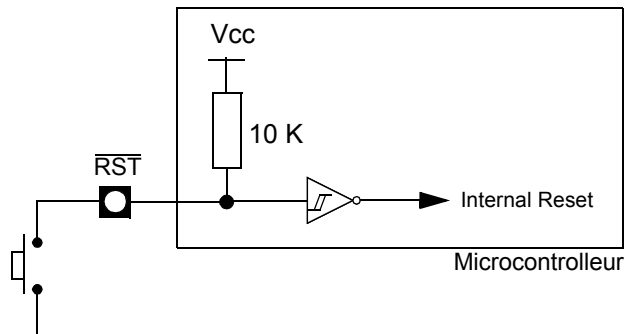

Reset Controlled by an External Supervisor Device

As the reset pin can be forced in output by the Watch-Dog timer (WDT) or the POR/PFD features, there can be a conflict between the external supervisor device and the microcontroller's reset pin when in one side the external supervisor is pulling the reset pin to VCC and in another side the WDT or POR/PFD features tries to force the reset pin to ground. Therefore, it is recommended to insert a series resistor of 1.8K +/-10% or a diode (1N4148 for instance) between the external supervisor device and the reset pin as detailed in the following figures.

Figure 105. Use of an External Serial Resistor

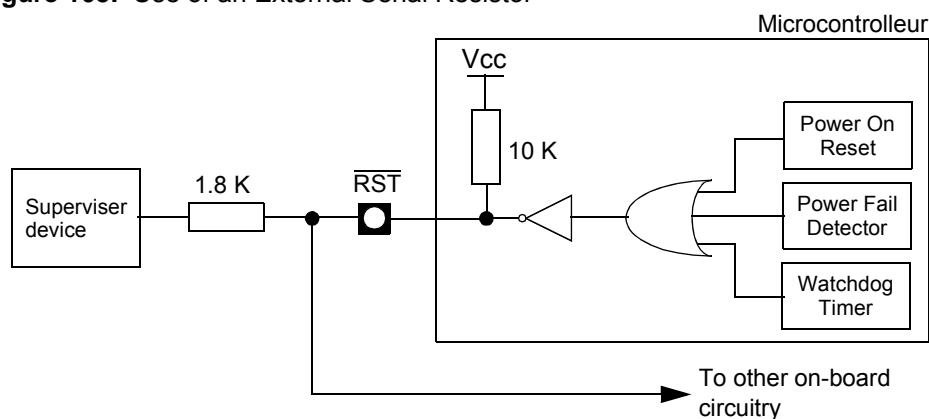
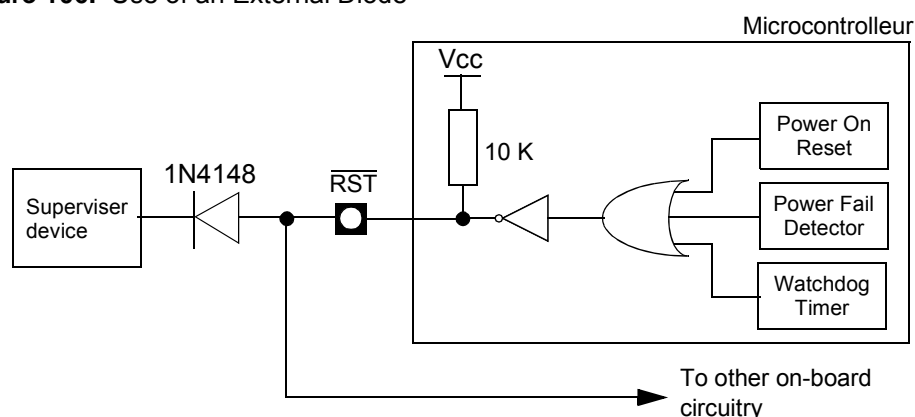

Figure 106. Use of an External Diode



Watchdog Timer

The AT83R5122, AT8xC5122/23 microcontrollers contain a powerful programmable hardware Watchdog Timer (WDT) that automatically resets the chip if its software fails to reset the WDT before the selected time interval has elapsed. It permits large timeout ranking from 4ms to 524ms @ $F_{CK_WD} = 24 \text{ MHz} / X2$

This WDT consists of a 14-bit counter plus a 7-bit programmable counter, a Watchdog Timer reset register (WDTRST) and a Watchdog Timer programming (WDTPRG) register. When exiting the reset, the WDT is, by default, disabled. To activate the WDT, the user has to write the sequence 1EH and E1H into WDTRST register. When the Watchdog Timer is enabled, it will increment every machine cycle while the oscillator is running and there is no way to disable the WDT except through reset (either hardware reset or WDT overflow reset). When WDT overflows, it will generate an output RESET pulse at the RST pin. The RESET pulse duration is $96 \times T_{OSC}$, where $T_{OSC} = 1/F_{OSC}$. To make the best use of the WDT, it should be serviced in those sections of code that will periodically be executed within the time required to prevent a WDT reset.

The WDT is controlled by two registers (WDTRST and WDTPRG).

Figure 107. Watchdog Timer

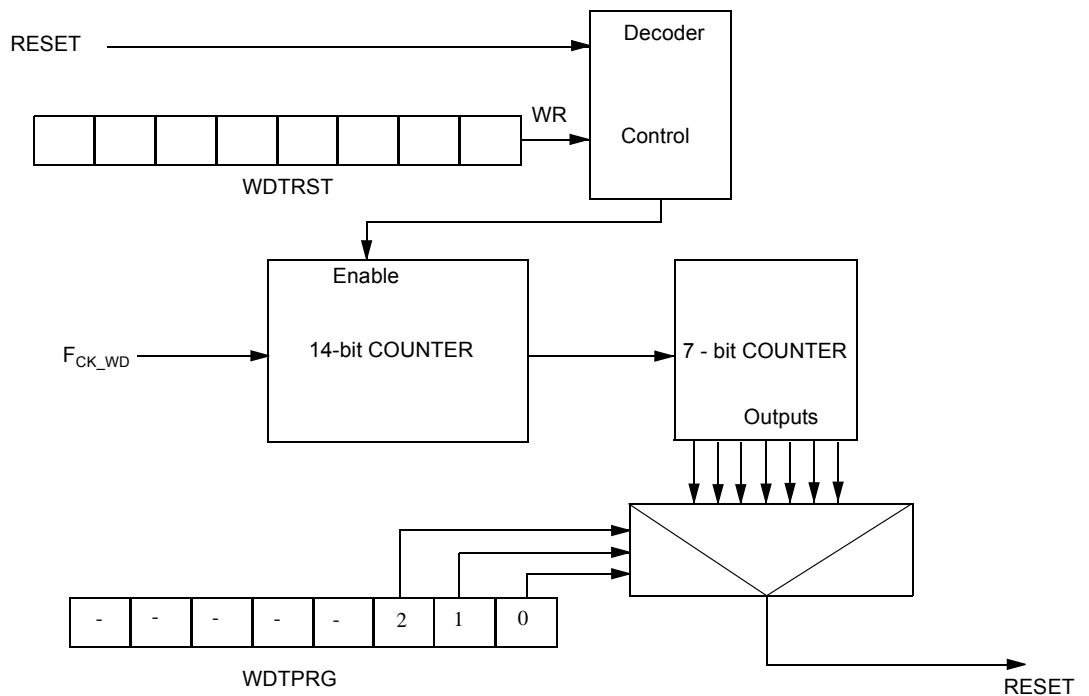

Table 109. Watchdog Timer Out Register - WDTPRG (0A7h)

7	6	5	4	3	2	1	0
-	-	-	-	-	S2	S1	S0

Bit Number	Bit Mnemonic	Description
7 - 3	-	Reserved The value read from this bit is indeterminate. Do not change these bits.
2	S2	WDT Time-out select bit 2
1	S1	WDT Time-out select bit 1
0	S0	WDT Time-out select bit 0

Reset Value = XXXX X000b

The three lower bits (S0, S1, S2) located into WDTPRG register enables to program the WDT duration.

Table 110. Machine Cycle Count

S2	S1	S0	Machine Cycle Count
0	0	0	$2^{14} - 1$
0	0	1	$2^{15} - 1$
0	1	0	$2^{16} - 1$
0	1	1	$2^{17} - 1$
1	0	0	$2^{18} - 1$
1	0	1	$2^{19} - 1$
1	1	0	$2^{20} - 1$
1	1	1	$2^{21} - 1$

To compute WD Timeout, the following formula must be applied:

$$\text{Time Out} = 6 * (2^{14} * 2^{\text{Svalue}} - 1) / F_{\text{CK_WD}}$$

Note: Svalue represents the decimal value of (S2 S1 S0)

Table 111. Timeout value for $F_{CK_WD} = 24 \text{ MHz} / X2$

S2	S1	S0	Timeout for $F_{CK_WD} = 24 \text{ MHz} / X2$
0	0	0	4.10 ms
0	0	1	8.19 ms
0	1	0	16.38 ms
0	1	1	32.77 ms
1	0	0	65.54 ms
1	0	1	131.07 ms
1	1	0	262.14 ms
1	1	1	524.29 ms

Table 112. Watchdog Timer Enable register (Write Only) - WDTRST (A6h)

7	6	5	4	3	2	1	0
-	-	-	-	-	-	-	-

Reset Value = XXXX XXXXb

The WDTRST register is used to reset / enable the WDT by writing 1EH then E1H in sequence.



Power Management

Before activating the Idle Mode or Power Down Mode, the CPU clock must be switched to on-chip oscillator source if the PLL is used to fed the CPU clock.

Idle Mode

An instruction that sets PCON.0 indicates that it is the last instruction to be executed before going into the Idle mode. In the Idle mode, the internal clock signal is gated off to the CPU, but not to the interrupt, Timer, and Serial Port functions. The CPU status is preserved in its entirety: the Stack Pointer, Program Counter, Program Status Word, Accumulator and all other registers maintain their data during Idle. The port pins hold the logical states they had at the time Idle was activated. ALE and PSEN hold at logic high level.

There are two ways to terminate the Idle mode. Activation of any enabled interrupt will cause PCON.0 to be cleared by hardware, terminating the Idle mode. The interrupt will be serviced, and following RETI the next instruction to be executed will be the one following the instruction that put the device into idle.

The flag bits GF0 and GF1 can be used to give an indication if an interrupt occurred during normal operation or during an Idle. For example, an instruction that activates Idle can also set one or both flag bits. When Idle is terminated by an interrupt, the interrupt service routine can examine the flag bits.

The other way of terminating the Idle mode is with a hardware reset. Since the clock oscillator is still running, the hardware reset needs to be held active for only two machine cycles (24 oscillator periods) to complete the reset.

Power Down Mode

To save maximum power, a power-down mode can be invoked by software (see Table 13, PCON register).

WARNING: To minimize power consumption, all peripherals and I/Os with static current consumption must be set in the proper state. I/Os programmed with low speed output configuration (KB_OUT) must be switch to push-pull or Standard C51 configuration before entering power-down. The CVCC generator must also be switch off.

In power-down mode, the oscillator is stopped and the instruction that invoked power-down mode is the last instruction executed. The internal RAM and SFRs retain their value until the power-down mode is terminated. V_{CC} can be lowered to save further power. Either a hardware reset or an external interrupt can cause an exit from power-down. To properly terminate power-down, the reset or external interrupt should not be executed before V_{CC} is restored to its normal operating level and must be held active long enough for the oscillator to restart and stabilize.

Only external interrupts $\overline{INT0}$, $\overline{INT1}$, Keyboard, Card insertion/removal and USB Interrupts are useful to exit from power-down. For that, interrupt must be enabled and configured as level or edge sensitive interrupt input. When Keyboard Interrupt occurs after a power-down mode, 1024 clocks are necessary to exit to power-down mode and enter in operating mode.

Holding the pin low restarts the oscillator but bringing the pin high completes the exit as detailed in Figure 108. When both interrupts are enabled, the oscillator restarts as soon as one of the two inputs is held low and power-down exit will be completed when the first input is released. In this case, the higher priority interrupt service routine is executed. Once the interrupt is serviced, the next instruction to be executed after RETI will be the one following the instruction that put AT83R5122, AT8xC5122/23 into power-down mode.

Figure 108. Power-down Exit Waveform

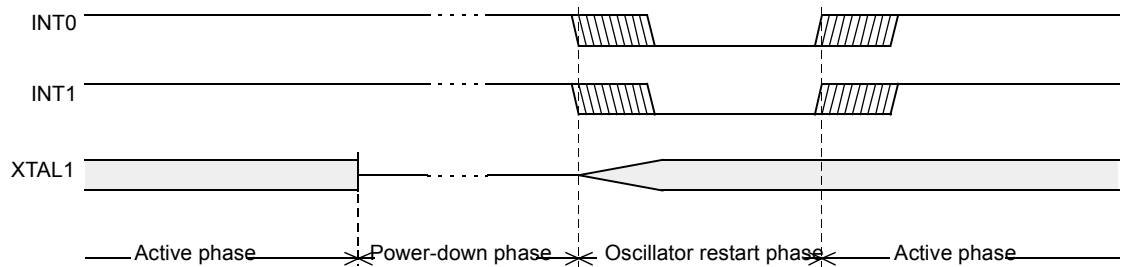

Exit from power-down by reset redefines all the SFRs, exit from power-down by external interrupt does not affect the SFRs.

Exit from power-down by either reset or external interrupt does not affect the internal RAM content.

Note: If idle mode is activated with power-down mode (IDL and PD bits set), the exit sequence is unchanged, when execution is vectored to interrupt, PD and IDL bits are cleared and idle mode is not entered.

Table shows the state of ports during idle and power-down modes.

Table State of Ports

Mode	Program Memory	ALE	PSEN	P0	P1	P2	P3	P4	P5
Idle	Internal	1	1	Port Data ⁽¹⁾	Port Data	Port Data	Port Data	Port Data	Port Data
Idle	External	1	1	Floating	Port Data	Address	Port Data	Port Data	Port Data
Power-down	Internal	0	0	Port Dat*	Port Data	Port Data	Port Data	Port Data	Port Data
Power-down	External	0	0	Floating	Port Data	Port Data	Port Data	Port Data	Port Data

Note: 1. Port 0 can force a 0 level. A "one" will leave port floating.

Reduced EMI Mode

The ALE signal is used to demultiplex address and data buses on port 0 when used with external program or data memory. Nevertheless, during internal code execution, ALE signal is still generated. In order to reduce EMI, ALE signal can be disabled by setting AO bit.

The AO bit is located in AUXR register at bit location 0. As soon as AO is set, ALE is no longer output but remains active during MOVX and MOVC instructions and external fetches. During ALE disabling, ALE pin is weakly pulled high.



USB Interface

Suspend

The Suspend state can be detected by the USB controller if all the clocks are enabled and if the USB controller is enabled. The bit SPINT is set by hardware when an idle state is detected for more than 3 ms. This triggers a USB interrupt if enabled.

In order to reduce current consumption, the firmware can put the USB PAD in idle mode, stop the clocks and put the C51 in Idle or Power-down mode. The Resume detection is still active.

The USB PAD is put in idle mode when the firmware clear the SPINT bit. In order to avoid a new suspend detection 3ms later, the firmware has to disable the USB clock input using the SUSPCLK bit in the USBCON Register. The USB PAD automatically exits of idle mode when a wake-up event is detected.

The stop of the 48 MHz clock from the PLL should be done in the following order:

1. Disable of the 48 MHz clock input of the USB controller by setting to 1 the SUSPCLK bit in the USBCON register.
2. If CPU clock is fed from PLL, the on-chip oscillator must be selected to feed the CPU clock.
3. Disable the PLL by clearing the PLEN bit in the PLLCON register.

Resume

When the USB controller is in Suspend state, the Resume detection is active even if all the clocks are disabled and if the C51 is in Idle or Power-down mode. The WUPCPU bit is set by hardware when a non-idle state occurs on the USB bus. This triggers an interrupt if enabled. This interrupt wakes up the CPU from its Idle or Power-down state and the interrupt function is then executed. The firmware will first enable the 48 MHz generation and then reset to 0 the SUSPCLK bit in the USBCON register if needed.

The firmware has to clear the SPINT bit in the USBINT register before any other USB operation in order to wake up the USB controller from its Suspend mode.

The USB controller is then re-activated.

Figure 109. Example of a Suspend/Resume Management

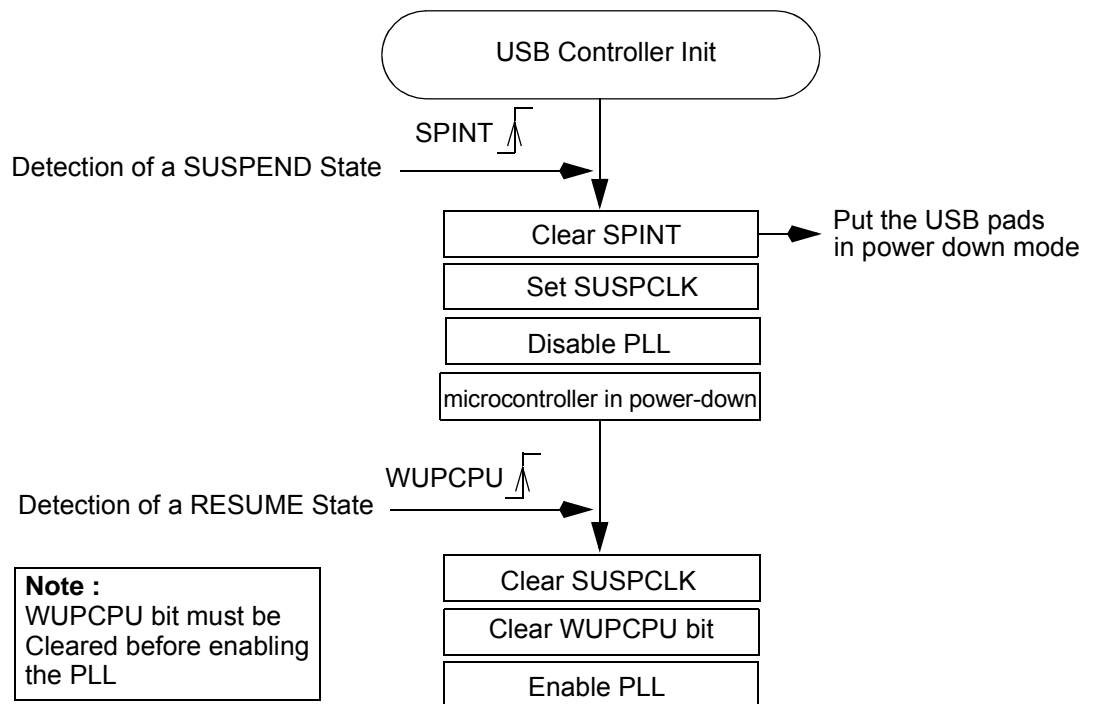

Warning: The core must be switched in external clock mode before disabling the PLL.

Smart Card Interface

Entering in Power-down Mode In order to reduce the power consumption, a power-down or idle mode can be invoked by software (see Table 13, PCON register). Before activating these modes the application will need to:

Power-off the Smart Card Interface by applying the following sequence:

- Set CRST pin at low level by clearing the bit CARDRST in SCCON register.
- Set CCLK pin at low level by clearing the bit CLK then the CARDCLK in SCCON register.
- Set CIO pin at low level by clearing the bit UART in SCICR register then the bit CARDIO in SCCON register.
- Power the Smart Interface off by clearing the CARDVCC bit in SCCON register. This instruction enables to switch DC/DC converter off.

CPRES input:

- Set the bit PRSEN in ISEL register
- Set the bit EX1 in IE0 register
- Set the bit EA in the IE0 register
- Invert the bit CPLEV in ISEL register (INT1 interrupt vector)
- Clear the bit PRESIT in the ISEL register



Exiting from Power-down Mode

The microcontroller will exit from Power-down or Idle modes upon a reset or INT1 interrupt which is a multiplexing of the interruptions generated by the CPRES pin (Card detection), RxD flag (UART reception) and INT1 pin.

Keyboard Interface

The keyboard interface applies only to AT8xC5122 version.

Entering in Power-down Mode

In order to reduce the power consumption, the microcontroller can be set in power-down or idle mode by software (see Table 13, PCON register). Before activating these modes the application will need to configure the keyboard interface as follows:

- Set all keyboard's outputs pins KB Rx at low level by writing a 0 on the ports. This operation has a double effect:
 - any key that is pressed generates an interrupt capable of waking-up the microcontroller,
 - Set all bits KBE.x in KBE registers to enable interrupts.

Exiting from Power-down Mode

The microcontroller will exit from Power-down Mode upon a reset or any interrupt generated by a key press. Note that 1024 clocks are necessary to exit from power-down mode when a keyboard interrupt occurs. This means that there will be a delay between the time at which the key is pressed and the time at which the application is able to identify the key.

Watchdog Timer during Power-down and Idle Mode

In Power-down mode the oscillator stops, which means the WDT also stops. While in Power-down mode the user does not need to service the WDT. There are 2 methods of exiting Power-down mode : by a hardware reset or by a level activated external interrupt which is enabled prior to entering power-down mode. When Power-down is exited with hardware reset, servicing the WDT should occur as it normally does whenever AT8xC5122D is reset. Exiting Power-down with an interrupt is significantly different. The interrupt is held low long enough for the oscillator to stabilize. When the interrupt is brought high, the interrupt is serviced. To prevent the WDT from resetting the device while the interrupt pin is held low, the WDT is not started until the interrupt is pulled high. It is suggested that the WDT be reset during the interrupt service for the interrupt used to exit Power-down.

To ensure that the WDT does not overflow within a few states of exiting of powerdown, it is best to reset the WDT just before entering powerdown.

In the Idle mode, the oscillator continues to run. To prevent the WDT from resetting while the microcontroller is in Idle mode, the user should always set up a timer that will periodically exit Idle, service the WDT, and re-enter Idle mode.

Registers

Table 113. Power Control Register - PCON (S:87h)

7	6	5	4	3	2	1	0
SMOD1	SMOD0	-	POF	GF1	GF0	PD	IDL
Bit Number	Bit Mnemonic	Description					
7	SMOD1	Serial Port Mode bit 1 for UART Set to select double baud rate in mode 1,2 or 3					
6	SMOD0	Serial Port Mode bit 0 for UART Cleared to select SM0 bit in SCON register Set to select FE bit in SCON register					
5	-	Reserved The value read from this bit is indeterminate. Do not change this bit.					
4	POF	Power-Off Flag (Only for ROM version parts) Cleared to recognize next reset type Set by hardware when VCC rises from 0 to its nominal voltage. Can also be set by software Warning : in CRAM and FLASH versions, this bit is reserved.					
3	GF1	General purpose Flag Cleared by user for general-purpose usage Set by user for general-purpose usage					
2	GF0	General purpose Flag Cleared by user for general-purpose usage Set by user for general-purpose usage					
1	PD	Power-Down mode bit Cleared by hardware when reset occurs Set to enter power-down mode					
0	IDL	Idle mode bit Cleared by hardware when interrupt or reset occurs Set to enter idle mode					

Reset Value = 00X1 0000b

Power-off flag reset value will be 1 only after a power on (cold reset). A warm reset doesn't affect the value of this bit.



Electrical Characteristics

Absolute Maximum Ratings

Ambiant Temperature Under Bias	-25°C to 85°C
Storage Temperature	-65°C to + 150°C
Voltage on V _{CC} to V _{SS}	-0.5 V to + 6.0V
Voltage on Any Pin to V _{SS}	-0.5 V to V _{CC} + 0.5 V
Power Dissipation	1 W

Note: Stresses at or above those listed under “Absolute Maximum Ratings” may cause permanent damage to the device. This is a stress rating only and functional operation of the device at these or any other conditions above those indicated in the operational sections of this specification is not implied. Exposure to absolute maximum rating conditions may affect device reliability.
Power Dissipation value is based on the maximum allowable die temperature and the thermal resistance of the package.

DC Parameters

T_A = -40 to +85°C; V_{SS} = 0 V, F_{CK_CPU} = 0 to 24 MHz, V_{CC} = 3.0V to 5.5V

Symbol	Parameter	Min	Typ	Max	Unit	Test Conditions
V _{IL}	Input Low Voltage	-0.5		0.2 V _{CC} - 0.1	V	
V _{IH}	Input High Voltage except XTAL1, \overline{RST}	0.2 V _{CC} + 0.9		V _{CC} + 0.5	V	
V _{IH1}	Input High Voltage, XTAL1, \overline{RST}	0.7 V _{CC}		V _{CC} + 0.5	V	
V _{OL}	Output Low Voltage: P0, ALE, PSEN			0.45	V	I _{OL} = 1.6 mA
V _{OH}	Output High Voltage: P0, ALE, PSEN	0.9 V _{CC}			V	I _{OH} = 10 μA
V _{OL1}	Output Low Voltage: P2, P3, P4, P5, P1.2, P1.6, P1.7			0.45	V	I _{OL} = 0.8 mA
V _{OH1}	Output High Voltage: P2, P3, P4, P5, P1.2, P1.6, P1.7	0.9 V _{CC}			V	I _{OH} = -10 μA
I _{IL}	Logical 0 Input Current ports 2 to 5 and P1.2, P1.6, P1.7, if Weak pull-up enabled			-50	μA	V _{in} = 0.45 V
I _{LI}	Input Leakage Current			±10	μA	0.45 V < V _{IN} < V _{CC}
I _{TL}	Logical 1 to 0 transition Current, Port 51 configuration			-650	μA	V _{IN} = 2 V
R _{MEDIUM}	Medium Pullup Resistor		10		kΩ	
R _{WEAK}	Weak Pullup Resistor		100		kΩ	
C _{IO}	Capacitance of I/O Buffer			10	pF	F _c = 1MHz T _A = 25°C
DV _{CC}	Digital Supply Voltage	3	3.4	3.6	V	C _L = 470 nF
D _I _{CC}	Digital Supply Output Current (DV _{CC} pin)			10	mA	C _L = 100 nF F _{CK_CPU} = 24 MHz
V _{PFDP}	Power Fail High Level Threshold		2.8	3	V	
V _{PFDM}	Power Fail Low Level Threshold	2.5	2.6		V	
t _{rise} , t _{fall}	V _{DD} rise and fall time	1μs		600	second	

Symbol	Parameter	Min	Typ	Max	Unit	Test Conditions
R_{RST}	Internal reset pull-up resistor	5	10	30	$k\Omega$	
I_{PD}	Power down consumption		60 μ A 40 μ A	200 μ A 200 μ A		V _{CC} = 5.5V V _{CC} = 3.6V
I_{CCIDLE}	Power Supply current in IDLE mode			0.4*F+2	mA	V _{CC} = 5.5V (F in MHz)
I_{CCOP}	Power Supply current in Active mode (AT89C5122) with DC/DC ON			1.6*F+3	mA	V _{CC} = 5.5V (F in MHz)
I_{CCOP}	Power Supply current in Active mode (AT85C5122) with DC/DC ON			1.6*F+3	mA	V _{CC} = 5.5V (F in MHz)
I_{CCOP}	Power Supply current in Active mode (AT83C5122) with DC/DC ON			1.6*F+2	mA	V _{CC} = 5.5V (F in MHz)
$I_{CCWRITE}$	Power Supply current in Active mode (AT89C5122) Flash or E2PROM write DC/DC ON			1.6*F+4	mA	V _{CC} = 5.5V (F in MHz)
I_{CCOP}	Power Supply current in Active mode (AT89C5122) with DC/DC OFF			0.8*F+3	mA	V _{CC} = 5.5V (F in MHz)
I_{CCOP}	Power Supply current in Active mode (AT85C5122) with DC/DC FF			0.8*F+3	mA	V _{CC} = 5.5V (F in MHz)
I_{CCOP}	Power Supply current in Active mode (AT83C5122) with DC/DC OFF			0.8*F+2	mA	V _{CC} = 5.5V (F in MHz)
$I_{CCWRITE}$	Power Supply current in Active mode (AT89C5122) Flash or E2PROM write DC/DC OFF			0.8*F+4	mA	V _{CC} = 5.5V (F in MHz)

I_{CC} Current Test Conditions

Figure 110. Power Down Mode

All other pins are disconnected.

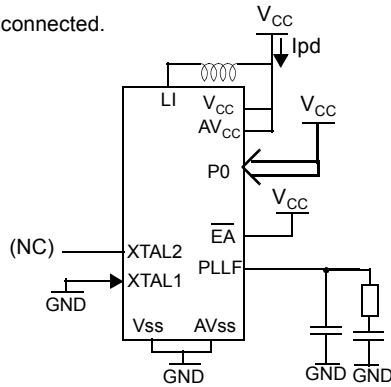
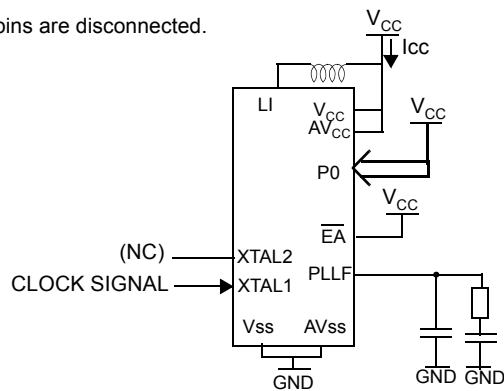

Figure 111. Active and Idle Mode

All other pins are disconnected.



LED's

Symbol	Parameter	Min	Typ	Max	Unit	Test Conditions
I _{OL}	Output Low Current, P3.0 and P3.7 LED modes	1	3	5	mA	2 mA configuration
		2	6	8	mA	4 mA configuration
		5	10	20	mA	10 mA configuration

Note: 1. (T_A = -20°C to +50°C, V_{CC} - V_{OL} = 2 V)

Smart Card Interface

Card VCC 5V (for IEC7816-3 Class A cards)

Symbol	Parameter	Min	Typ	Max	Unit	Test Conditions
V _{CC}	Power Supply	3.0		5.5	V	
Cl _{CC_ovf}	Card Supply Current overflow		100		mA	
CV _{CC}	Card Supply Voltage	4.6		5.4	V	V _{cc} Min = 4.0V, Cl _{CC} = 60 mA V _{cc} Min = 3.0V, Cl _{CC} = 30 mA
	Ripple on Card Voltage			200	mV	0 < Cl _{CC} < 60 mA
CV _{CC}	Card Supply Voltage during spike on I _{CC}	4.5		5.5		Max. charge 20 nA.s Max. duration 400 ns Max. variation Cl _{CC} 100 mA
T _{OFF}	CV _{CC} to 0			750	μs	Cl _{load} =10μF, L _{load} =10μH V _{card} = CV _{CC} to 0.4V
T _{ON}	0 to CV _{CC}			750	μs	Cl _{load} =10μF, L _{load} =10μH V _{card} = 0V to CV _{CC} With Boost at 60%

Card VCC 3V Power Supply (for IEC7816-3 Class B cards)

Symbol	Parameter	Min	Typ	Max	Unit	Test Conditions
V _{CC}	Power Supply	3.0		5.5	V	
Cl _{CC_ovf}	Card Supply Current overflow		100		mA	
CV _{CC}	Card Supply Voltage	2.76		3.24	V	V _{cc} Min = 3.6V, Cl _{CC} = 55mA V _{cc} Min = 3.0V, Cl _{CC} = 30 mA
	Ripple on V _{card}			200	mV	0 < Cl _{CC} < 55mA
CV _{CC}	Card Supply Voltage during spike on I _{CC}	2.7		3.3	V	Maxi. charge 10nA.s Max. duration 400 ns Max. variation Cl _{CC} 50mA
T _{OFF}	CV _{CC} to 0			750	μs	Cl _{load} =10μF, L _{load} =10μH V _{card} = CV _{CC} to 0.4V
T _{ON}	0 to CV _{CC}			750	μs	Cl _{load} =10μF, L _{load} =10μH V _{card} = 0V to CV _{CC} With Boost at 60%

Card VCC 1.8V Power Supply (for IEC7816-3 Class C cards)

Symbol	Parameter	Min	Typ	Max	Unit	Test Conditions
V _{CC}	Power Supply	3.0		5.5	V	
Cl _{CC_ovf}	Card Supply Current overflow		100		mA	
CV _{CC}	Card Supply Voltage	1.68		1.92	V	Cl _{CC} = 35 mA
T _{OFF}	CV _{CC} to 0			750	μs	Cl _{CC} = 10μF, L _{load} = 10μH V _{card} = CV _{CC} to 0.4V
T _{ON}	0 to CV _{CC}			750	μs	Cl _{CC} = 10μF, L _{load} = 10μH V _{card} = 0V to CV _{CC} With Boost at 60%

- Notes: 1. Test conditions, Capacitor 10 μF, Inductance 10 μH.
2. Ceramic X7R, SMD type capacitor with minimum ESR or 250 mΩ is mandatory

Smart Card CCLK, DC parameters

Symbol	Parameter	Min	Typ	Max	Unit	Test Conditions
V _{OL}	Output Low Voltage	0 ⁽¹⁾		0.4 0.15 CV _{CC} 0.15 CV _{CC}	V	I _{OH} = 50 μA (5V until 2009) I _{OH} = 100 μA (5V from 2009) I _{OH} = 100 μA (3V & 1.8V)
I _{OL}	Output Low Current			15	mA	
V _{OH}	Output High Voltage	CV _{CC} -0.5 0.8 CV _{CC} 0.8 CV _{CC}		CV _{CC}	V	I _{OH} = 50μA (+5V until 2009) I _{OH} = 100 μA (+5V from 2009) I _{OH} = 100 μA (+3V & 1.8V)
I _{OH}	Output High Current			15	mA	
t _R t _F	Rise and Fall delays			14.5 15.5 32	ns	C _{IN} = 30pF (5V) C _{IN} = 30pF (3V) C _{IN} = 30pF (1.8V)
	Voltage Stability	-0.25 CV _{CC} -0.5		0.4 CV _{CC} CV _{CC} + 0.25	V	Low level High level
	Frequency variation (Jitter)			1%		
	Cycle ratio	45%		55%		

- Notes: 1. The voltage on CLK should remain between -0.3V and V_{CC}+0.3V during dynamic operation.

Smart Card CIO, DC Parameters

Symbol	Parameter	Min	Typ	Max	Unit	Test Conditions
V _{IL}	Input Low Voltage	0 ⁽¹⁾		0.2 CV _{CC}	V	
I _{IL}	Input Low Current			500	μA	
V _{IH}	Input High Voltage	0.6 CV _{CC}		CV _{CC}	V	
I _{IH}	Input High Current			-20 / +20	μA	
V _{OL}	Output Low Voltage	0 ⁽¹⁾		0.15 CV _{CC}	V	I _{OL} = 1mA (5V & 3V)) I _{OL} = 0.5 mA (1.8V) External 10K pull-up tied to CV _{CC}

Smart Card CIO, DC Parameters

Symbol	Parameter	Min	Typ	Max	Unit	Test Conditions
I_{OL}	Output Low Current			15	mA	
V_{OH}	Output High Voltage	$0.8 CV_{CC}$		$CV_{CC} (1)$	V	$I_{OH} = 20 \mu A$ External 10K pull-up resistor tied to CV_{CC}
I_{OH}	Output High Current			15	mA	
	Voltage Stability	-0.25 $0.8 CV_{CC}$		0.4 $CV_{CC} + 0.25$	V	Low level High level
$t_R t_F$	Rise and Fall delays			0.8	μs	$C_{IN}=30pF$.

Note: 1. The voltage on RST should remain between -0.3V and $V_{CC}+0.3V$ during dynamic operation.

Smart Card RST, I/O, DC Parameters

Symbol	Parameter	Min	Typ	Max	Unit	Test Conditions
V_{OL}	Output Low Voltage	$0^{(1)}$		0.4 $0.12 CV_{CC}$ $0.12 CV_{CC}$	V	$I_{OL} = 50 \mu A$ (5V until 2009) $I_{OL} = 200 \mu A$ (5V from 2009) $I_{OL} = 200 \mu A$ (3V & 1.8V)
I_{OL}	Output Low Current			15	mA	
V_{OH}	Output High Voltage	$CV_{CC}-05$ $0.8 CV_{CC}$ $0.8 CV_{CC}$		$CV_{CC}^{(1)}$	V	$I_{OH} = 50 \mu A$ (+5V until 2009) $I_{OH} = 150 \mu A$ (+5V from 2009) $I_{OH} = 150 \mu A$ (+3V & 1.8V)
I_{OH}	Output High Current			15	mA	
$t_R t_F$	Rise and Fall delays			0.8	μs	$C_{IN}=30 pF$
	Voltage Stability	-0.25 $CV_{CC}-0.5$		0.4 CV_{CC} $CV_{CC} + 0.25$		Low level High level

Note: 1. The voltage on RST should remain between -0.3V and $V_{CC}+0.3V$ during dynamic operation.

Card Presence (P1.2) DC Parameters

Symbol	Parameter	Min	Typ	Max	Unit	Test Conditions
I_{OL1}	CPRES weak pull-up output current	3	10	25	μA	P1.2=1, short to VSS Pull-up enabled

USB Interface

Figure 112. USB Interface

Symbol	Parameter	Min	Typ ⁽⁵⁾	Max	Unit
V_{REF}	USB Reference Voltage	3.0		3.6	V
V_{IH}	Input High Voltage for D+ and D- (driven)	2.0		4.0	V
V_{IHZ}	Input High Voltage for D+ and D- (floating)	2.7		3.6	V
V_{IL}	Input Low Voltage for D+ and D-			0.8	V
V_{OH}	Output High Voltage for D+ and D-	2.8		3.6	V
V_{OL}	Output Low Voltage for D+ and D-	0.0		0.3	V

AC Parameters

Explanation of the AC Symbols

Each timing symbol has 5 characters. The first character is always a “T” (stands for time). The other characters, depending on their positions, stand for the name of a signal or the logical status of that signal. The following is a list of all the characters and what they stand for.

Example: T_{AVLL} = Time for Address Valid to ALE Low.

T_{LLPL} = Time for ALE Low to \overline{PSEN} Low.

$T_A = -40^\circ\text{C}$ to $+85^\circ\text{C}$; $V_{SS} = 0\text{V}$; $V_{CC} = 3.0\text{V}$ to 5.5V ; $F_{CK_CPU} = 0$ to 24 MHz .

(Load Capacitance for port 0, ALE and \overline{PSEN} = 60 pF ; Load Capacitance for all other outputs = 60 pF .)

Table and Table 118 give the description of each AC symbols.

Table 117 and Table 120 give for each range the AC parameter.

Table 115, Table 117 and Table 119 give the frequency derating formula of the AC parameter for each speed range description. To calculate each AC symbols. take the x value and use this value in the formula.

Example: T_{LLIV} and 20 MHz , Standard clock.

$x = 30\text{ ns}$

$T = 50\text{ ns}$

$T_{CCIV} = 4T - x = 170\text{ ns}$

External Program Memory Characteristics

Table 114. Symbol Description

Symbol	Parameter
T	CPU clock period (F_{CK_CPU})
T_{LHLL}	ALE pulse width
T_{AVLL}	Address Valid to ALE
T_{LLAX}	Address Hold After ALE
T_{LLIV}	ALE to Valid Instruction In
T_{LLPL}	ALE to \overline{PSEN}
T_{PLPH}	\overline{PSEN} Pulse Width
T_{PLIV}	\overline{PSEN} to Valid Instruction In
T_{PXIX}	Input Instruction Hold After \overline{PSEN}
T_{PXIZ}	Input Instruction Float After \overline{PSEN}
T_{AVIV}	Address to Valid Instruction In
T_{PLAZ}	\overline{PSEN} Low to Address Float

Table 115. AC Parameters for a Variable Clock

Symbol	Type	Standard clock	X2 Clock	X parameter	Units
T_{LHLL}	Min	$2T - x$	$T - x$	15	ns
T_{AVLL}	Min	$T - x$	$0.5 T - x$	20	ns
T_{LLAX}	Min	$T - x$	$0.5 T - x$	20	ns
T_{LLIV}	Max	$4T - x$	$2 T - x$	35	ns
T_{LLPL}	Min	$T - x$	$0.5 T - x$	15	ns
T_{PLPH}	Min	$3T - x$	$1.5 T - x$	25	ns
T_{PLIV}	Max	$3T - x$	$1.5 T - x$	45	ns
T_{PXIX}	Min	x	x	0	ns
T_{PXIZ}	Max	$T - x$	$0.5 T - x$	15	ns
T_{AVIV}	Max	$5T - x$	$2.5 T - x$	45	ns
T_{PLAZ}	Max	x	x	10	ns

External Program Memory Read Cycle

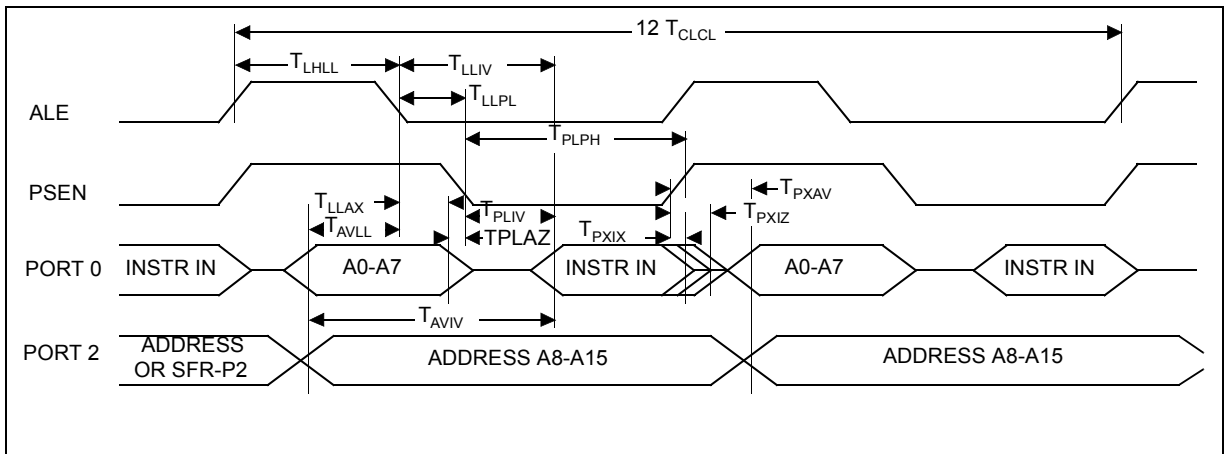

External Data Memory Characteristics

Table 116. Symbol Description

Symbol	Parameter
T_{RLRH}	\overline{RD} Pulse Width
T_{WLWH}	\overline{WR} Pulse Width
T_{RLDV}	\overline{RD} to Valid Data In
T_{RHDX}	Data Hold After \overline{RD}
T_{RHDZ}	Data Float After \overline{RD}
T_{LLDV}	ALE to Valid Data In
T_{AVDV}	Address to Valid Data In
T_{LLWL}	ALE to \overline{WR} or \overline{RD}
T_{AVWL}	Address to \overline{WR} or \overline{RD}
T_{QVWX}	Data Valid to \overline{WR} Transition
T_{QVWH}	Data set-up to \overline{WR} High
T_{WHQX}	Data Hold After \overline{WR}
T_{RLAZ}	\overline{RD} Low to Address Float
T_{WHLH}	\overline{RD} or \overline{WR} High to ALE high

Table 117. AC Parameters for a Variable Clock

Symbol	Type	Standard Clock	X2 Clock	X parameter	Units
T_{RLRH}	Min	$6T - x$	$3T - x$	20	ns
T_{WLWH}	Min	$6T - x$	$3T - x$	20	ns
T_{RLDV}	Max	$5T - x$	$2.5T - x$	25	ns
T_{RHDX}	Min	x	x	0	ns
T_{RHDZ}	Max	$2T - x$	$T - x$	20	ns
T_{LLDV}	Max	$8T - x$	$4T - x$	40	ns
T_{AVDV}	Max	$9T - x$	$4.5T - x$	60	ns
T_{LLWL}	Min	$3T - x$	$1.5T - x$	25	ns
T_{LLWL}	Max	$3T + x$	$1.5T + x$	25	ns
T_{AVWL}	Min	$4T - x$	$2T - x$	25	ns
T_{QVWX}	Min	$T - x$	$0.5T - x$	15	ns
T_{QVWH}	Min	$7T - x$	$3.5T - x$	25	ns
T_{WHQX}	Min	$T - x$	$0.5T - x$	10	ns
T_{RLAZ}	Max	x	x	0	ns
T_{WHLH}	Min	$T - x$	$0.5T - x$	15	ns
T_{WHLH}	Max	$T - x$	$0.5T + x$	15	ns

(warning x value differ from AT89C51RD2)

External Data Memory Write Cycle

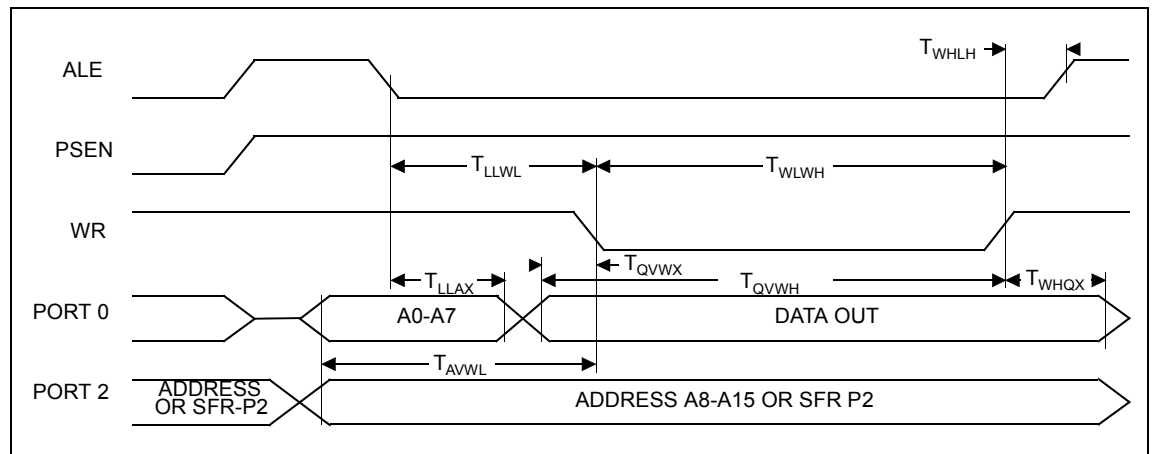

External Data Memory Read Cycle

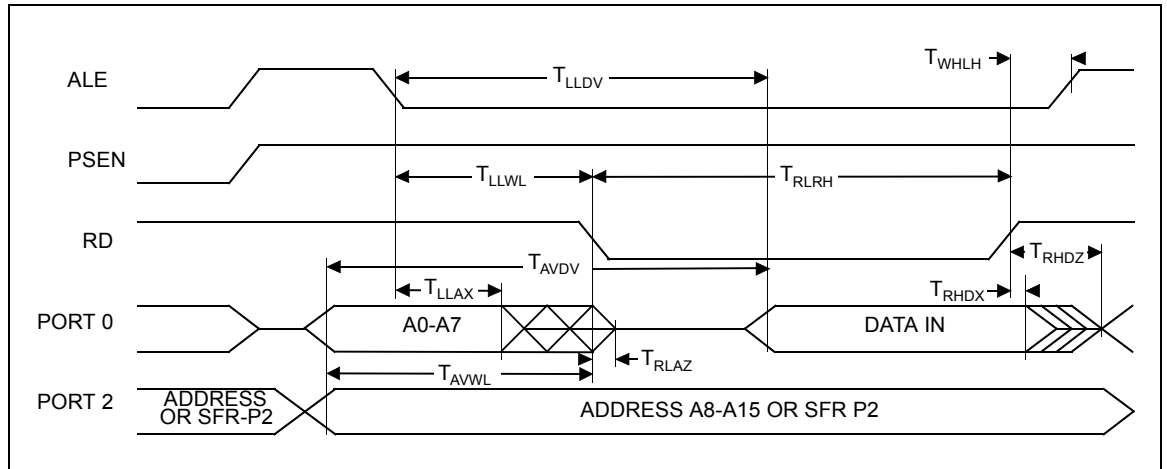

Serial Port Timing - Shift Register Mode

Table 118. Symbol Description (F = 40 MHz)

Symbol	Parameter
T_{XLXL}	Serial port clock cycle time
T_{QVHX}	Output data set-up to clock rising edge
T_{XHQX}	Output data hold after clock rising edge
T_{XHDX}	Input data hold after clock rising edge
T_{XHDV}	Clock rising edge to input data valid

Table 119. AC Parameters for a Variable Clock

Symbol	Type	Standard Clock	X2 Clock	X parameter	Units
T_{XLXL}	Min	12T	6 T		ns
T_{QVHX}	Min	10T - x	5 T - x	50	ns
T_{XHQX}	Min	2T - x	T - x	20	ns
T_{XHDX}	Min	x	x	0	ns
T_{XHDV}	Max	10T - x	5 T - x	133	ns

Shift Register Timing Waveform

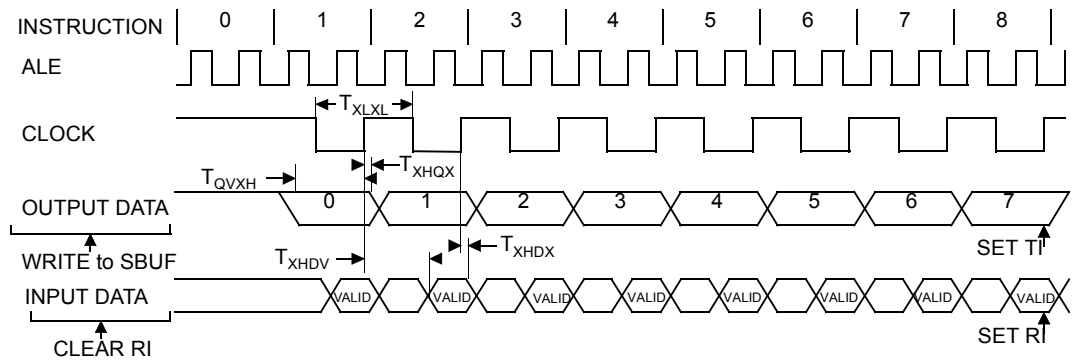

External Clock Drive Characteristics (XTAL1)

Table 120. AC Parameters

Symbol	Parameter	Min	Max	Units
T_{CLCL}	Oscillator Period	125		ns
T_{CHCX}	High Time	5		ns
T_{CLCX}	Low Time	5		ns
T_{CLCH}	Rise Time		5	ns
T_{CHCL}	Fall Time		5	ns
T_{CHCX}/T_{CLCX}	Cyclic ratio in X2 mode	40	60	%

External Clock Drive Waveforms

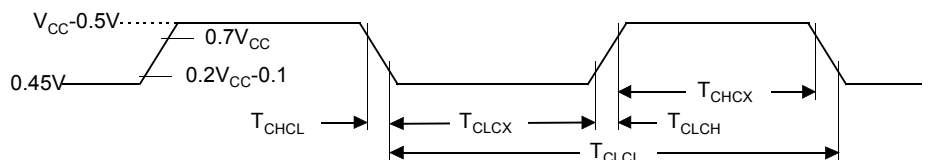

AC Testing Input/Output Waveforms

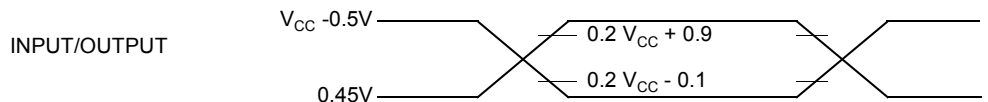

AC inputs during testing are driven at $V_{CC} - 0.5$ for a logic "1" and $0.45V$ for a logic "0". Timing measurement are made at V_{IH} min for a logic "1" and V_{IL} max for a logic "0".

Float Waveforms

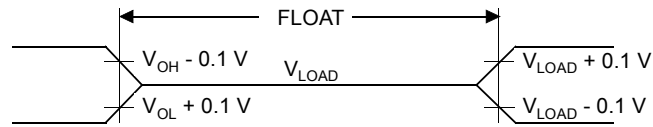

For timing purposes as port pin is no longer floating when a 100 mV change from load voltage occurs and begins to float when a 100 mV change from the loaded V_{OH}/V_{OL} level occurs. $I_{OL}/I_{OH} \geq \pm 20$ mA.

Clock Waveforms

Valid in normal clock mode. In X2 mode XTAL2 must be changed to XTAL2/2.

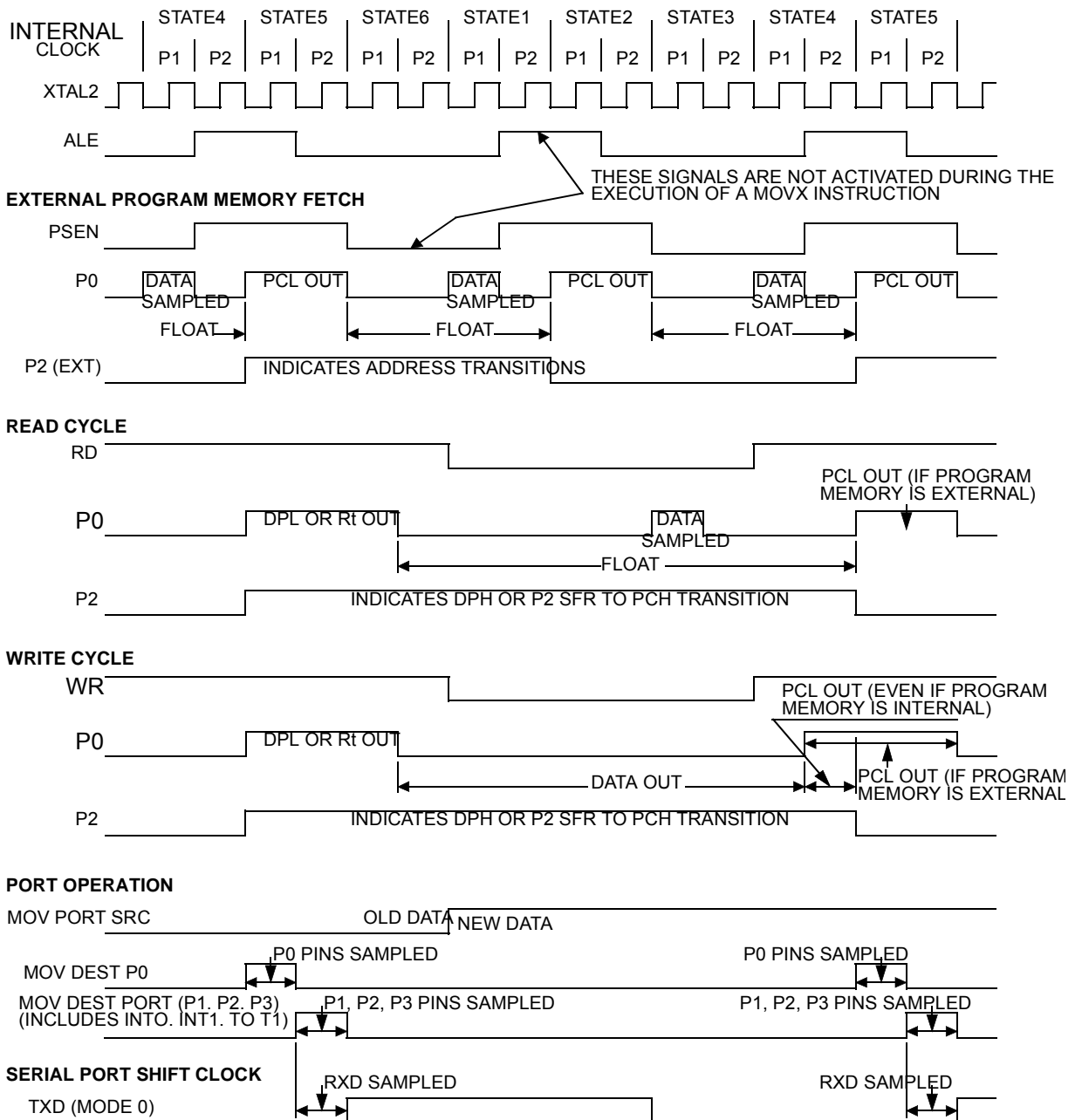

This diagram indicates when signals are clocked internally. The time it takes the signals to propagate to the pins, however, ranges from 25 to 125 ns. This propagation delay is dependent on variables such as temperature and pin loading. Propagation also varies from output to output and component. Typically though ($T_A=25^{\circ}\text{C}$ fully loaded) RD and WR propagation delays are approximately 50 ns. The other signals are typically 85 ns. Propagation delays are incorporated in the AC specifications.

USB Interface

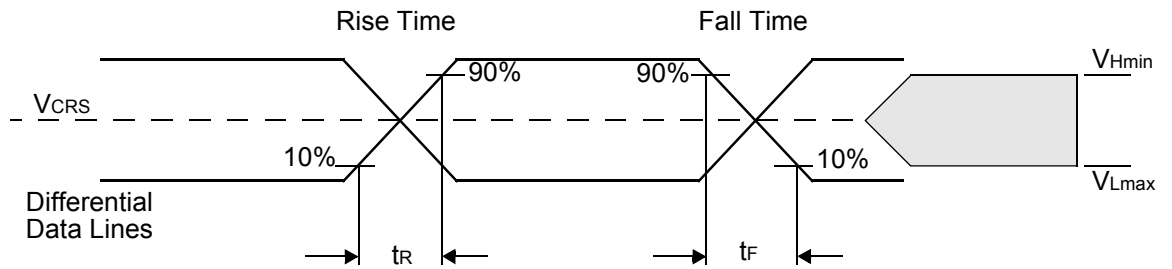

Symbol	Parameter	Min	Typ ⁽⁵⁾	Max	Unit
t_R	Rise Time	4		20	ns
t_F	Fall Time	4		20	ns
t_{FDRATE}	Full-speed Data Rate	11.9700		12.0300	Mb/s
V_{CRS}	Crossover Voltage	1.3		2.0	V
t_{DJ1}	Source Jitter Total to next transaction	-3.5		3.5	ns
t_{DJ2}	Source Jitter Total for paired transactions	-4		4	ns
t_{JR1}	Receiver Jitter to next transaction	-18.5		18.5	ns
t_{JR2}	Receiver Jitter for paired transactions	-9		9	ns

Packaging Information

Ordering Information

Lead free/ RoHS Part Number	Lead free/ RoHS Internal Part Number	Memory Size (bytes)	Supply Voltage (V)	Temperature Range	Max Frequency (MHz)	Package	Packing
AT83R5122xxx-RDTUM	AT83R5122xxx-ALTUM	32K ROM	3.0 - 5.5	Industrial	48 MHz / X1	VQFP64	Tray
AT83R5122xxx-RDRUM	AT83R5122xxx-ALRUM	32K ROM	3.0 - 5.5	Industrial	48 MHz / X1	VQFP64	Tape & Reel
AT83R5122xxx-PSTUM	AT83R5122xxx-Z1TUM	32K ROM	3.0 - 5.5	Industrial	48 MHz / X1	QFN64	Tray & Dry Pack
AT83R5122xxx-PSRUM	AT83R5122xxx-Z1RUM	32K ROM	3.0 - 5.5	Industrial	48 MHz / X1	QFN64	Tape & Reel & Dry Pack
AT85C5122D-RDTUM	AT85C5122D-ALTUM	32K CRAM	3.0 - 5.5	Industrial	48 MHz / X1	VQFP64	Tray
AT85C5122D-RDRUM	AT85C5122D-ALRUM	32K CRAM	3.0 - 5.5	Industrial	48 MHz / X1	VQFP64	Tape & Reel
AT89C5122D-RDTUM	AT89C5122D-ALTUM	32K FLASH	3.0 - 5.5	Industrial	48 MHz / X1	VQFP64	Tray & Dry pack
AT89C5122D-RDRUM	AT89C5122D-ALRUM	32K FLASH	3.0 - 5.5	Industrial	48 MHz / X1	VQFP64	Tape & Reel & Dry pack
AT89C5122D-PSTUM	AT89C5122D-Z1TUM	32K FLASH	3.0 - 5.5	Industrial	48 MHz / X1	QFN64	Tray & Dry Pack
AT89C5122D-PSRUM	AT89C5122D-Z1RUM	32K FLASH	3.0 - 5.5	Industrial	48 MHz / X1	QFN64	Tape & Reel & Dry Pack
AT89C5122DS-RDTUM	AT89C5122DS-ALTUM	32K FLASH	3.0 - 5.5	Industrial	48 MHz / X1	VQFP64	Tray & Dry Pack
AT89C5122DS-RDRUM	AT89C5122DS-ALRUM	32K FLASH	3.0 - 5.5	Industrial	48 MHz / X1	VQFP64	Tape & Reel & Dry Pack
AT89C5122D-PSTUM	AT89C5122D-Z1TUM	32K FLASH	3.0 - 5.5	Industrial	48 MHz / X1	QFN64	Tray & Dry Pack
AT89C5122D-PSRUM	AT89C5122D-Z1RUM	32K FLASH	3.0 - 5.5	Industrial	48 MHz / X1	QFN64	Tape & Reel & Dry Pack
AT83C5123xxx-RATUM	AT83C5123xxx-ALTUM	30K ROM	3.0 - 5.5	Industrial	48 MHz / X1	VQFP32	Tray
AT83C5123xxx-RARUM	AT83C5123xxx-ALRUM	30K ROM	3.0 - 5.5	Industrial	48 MHz / X1	VQFP32	Tape & Reel
AT83C5123xxx-PUTUM	AT83C5123xxx-Z1TUM	30K ROM	3.0 - 5.5	Industrial	48 MHz / X1	QFN32	Tray
AT83C5123xxx-PURUM	AT83C5123xxx-Z1RUM	30K ROM	3.0 - 5.5	Industrial	48 MHz / X1	QFN32	Tape & Reel

Note: 1. Check availability with sales office

Mechanical Dimensions

VQFP64 Package

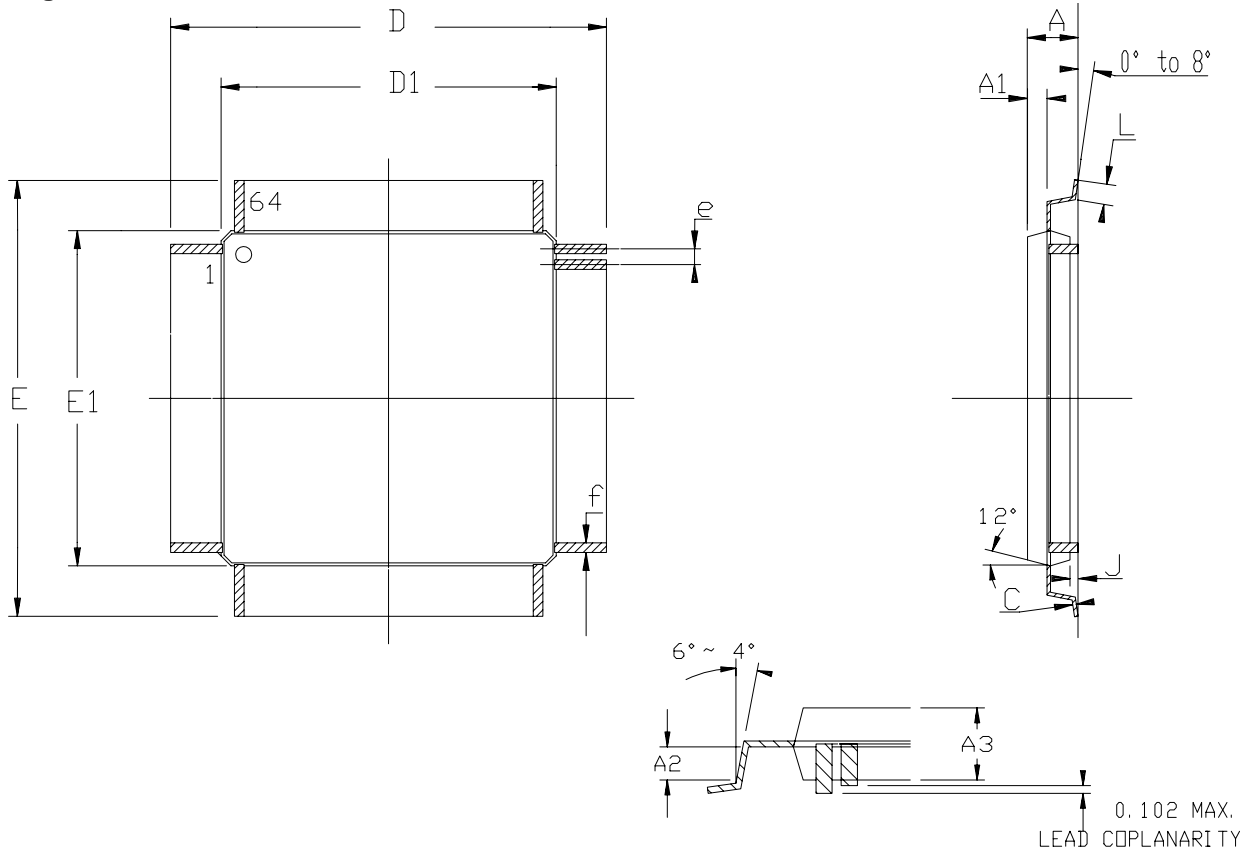

	MM		INCH	
	Min	Max	Min	Max
A	-	1.60	-	.063
A1	0.64 REF		.025 REF	
A2	0.64 REF		.025 REF	
A3	1.35	1.45	.053	.057
D	11.75	12.25	.463	.483
D1	9.90	10.10	.390	.398
E	11.75	12.25	.463	.483
E1	9.90	10.10	.390	.398
J	0.05	-	.002	-
L	0.45	0.75	.018	.030
e	0.50 BSC		.0197 BSC	
f	0.25 BSC		.010 BSC	

PLCC68 Package

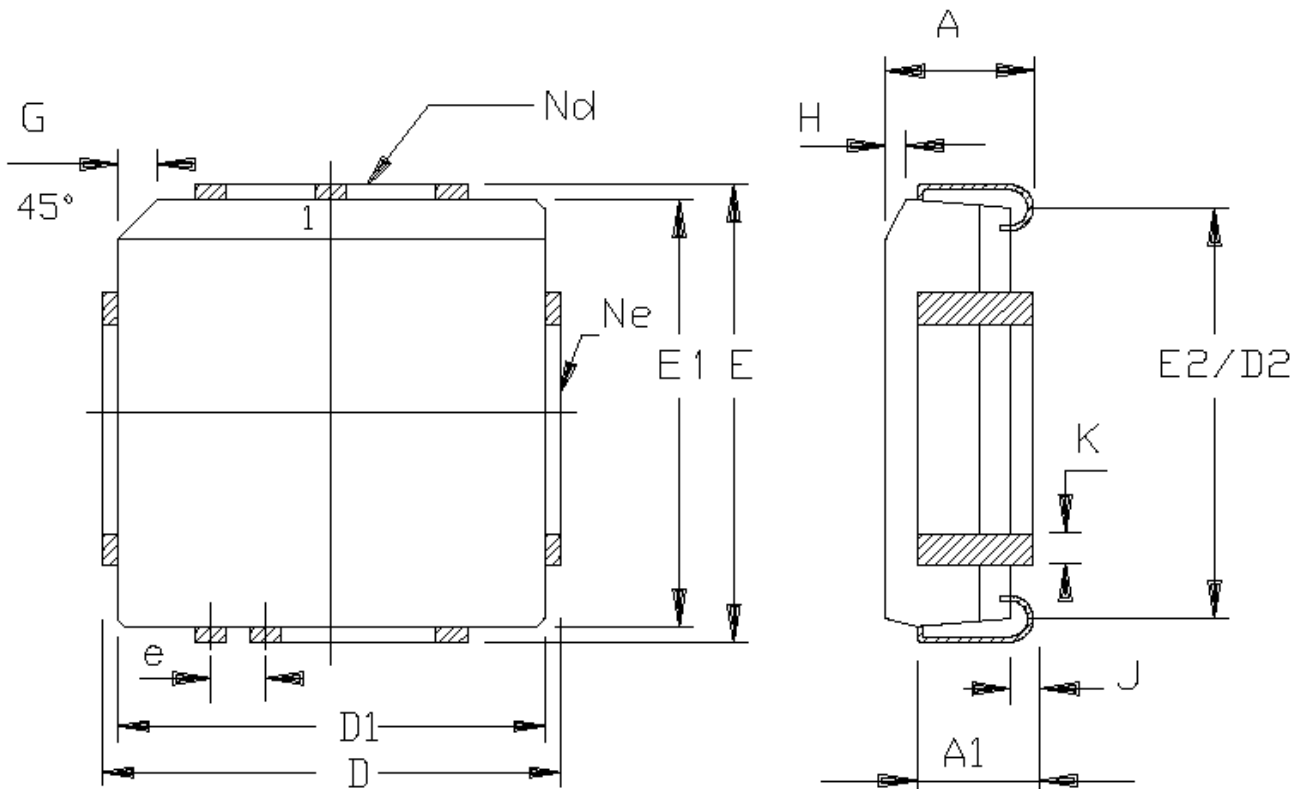

	MM		INCH	
A	4.20	5.08	.165	.200
A1	2.29	3.30	.090	.130
D	25.02	25.27	.985	.995
D1	24.13	24.33	.950	.958
D2	22.61	23.62	.890	.930
E	25.02	25.27	.985	.995
E1	24.13	24.33	.950	.958
E2	22.61	23.62	.890	.930
e	1.27	BSC	.050	BSC
G	1.07	1.22	.042	.048
H	1.07	1.42	.042	.056
J	0.51	-	.020	-
K	0.33	0.53	.013	.021
Nd	17		17	
Ne	17		17	

VQFP32 Package

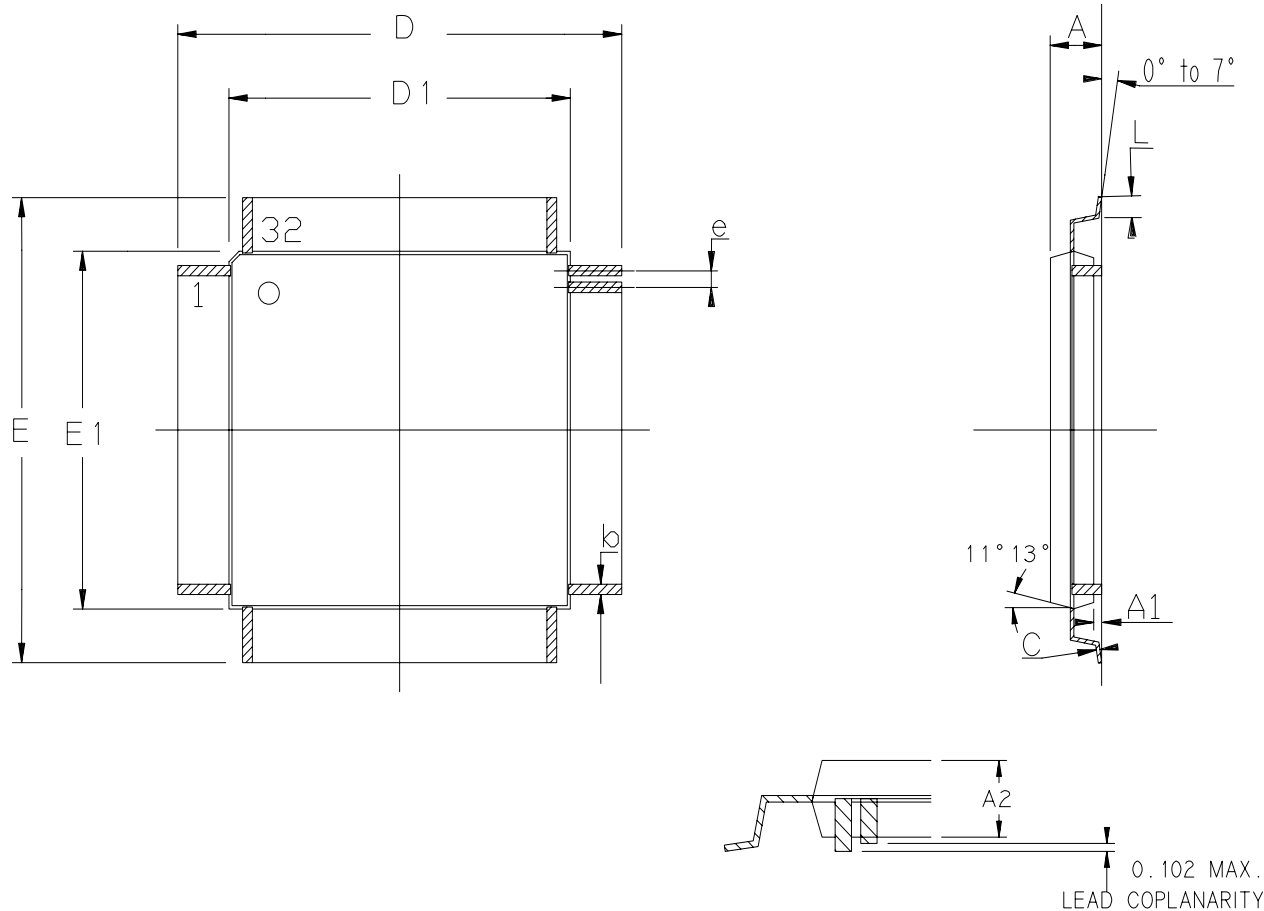

	MM		INCH	
	Min	Max	Min	Max
A	-	1.60	-	.063
A1	0.05	0.15	.002	.006
A2	1.35	1.45	.053	.057
C	0.09	0.20	.004	.008
D	9.00 BSC		.354 BSC	
D1	7.00 BSC		.276 BSC	
E	9.00 BSC		.354 BSC	
E1	7.00 BSC		.276 BSC	
L	0.45	0.75	.018	.030
e	0.80 BSC		.0315 BSC	
b	0.30	0.45	.012	.018

QFN32 Package

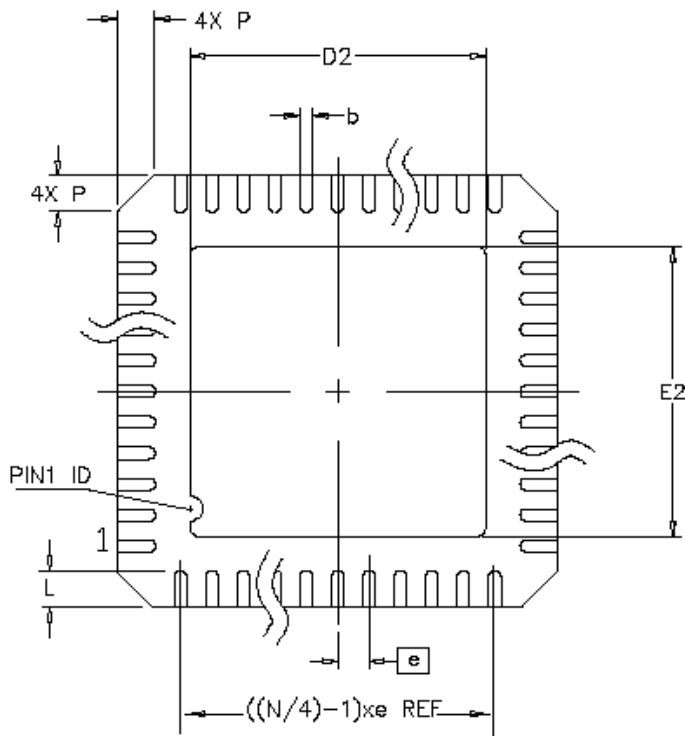
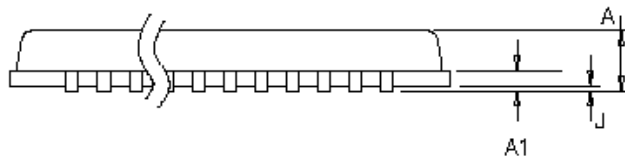
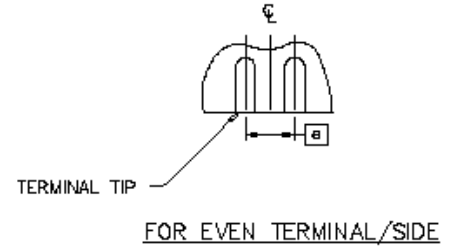
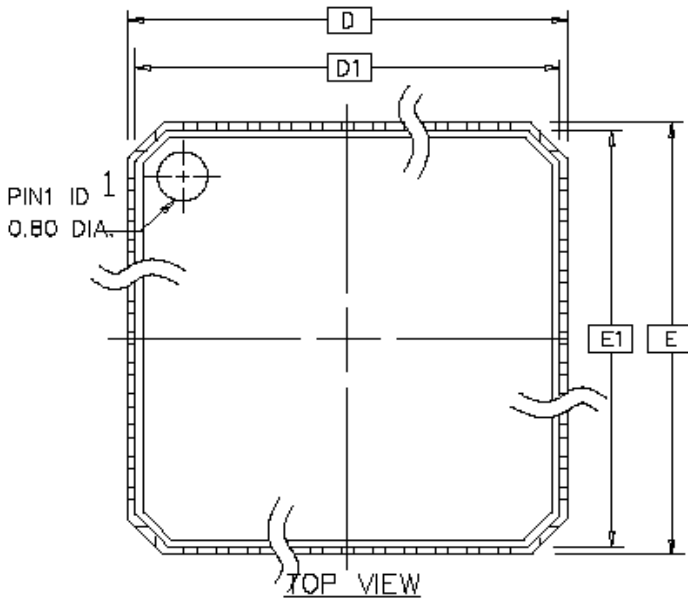

	MM			INCH		
	MIN	NOM	MAX	MIN	NOM	MAX
A	-	0.85	0.90	-	.033	.035
J	0.00	0.01	0.05	.000	.000	.002
A1	0.20 ref			.008 ref		
D/E	7.00 BSC			.276 BSC		
D1/E1	6.75 BSC			.266 BSC		
D2/E2	4.95	5.10	5.25	.195	.201	.207
N	32					
P	0.24	0.42	0.60	.009	.016	.024
e	0.65 BSC			.026 BSC		
L	0.50	0.60	0.75	.020	.024	.030
b	0.23	0.28	0.35	.009	.011	.014



Datasheet Revision History

Changes from 4202A to 4202B

1. Product AT8xEC5122 added.
2. Products AT83C5123 and AT83EC5123 added.

Changes from 4202B to 4202C

1. All sections updated.
2. QFN64 and QFN32 packages added.
3. SCIB section : VCC must be higher than 4.0V when DC/DC is operated at 5V.

Changes from 4202C to 4202D

1. Product AT89C5122DS added (EA pin changed to VCC)
2. Typical applications section: external pull-up shown on CIO pin
3. Ports section : Detailed explanations on CIO, CC4, CC8 quasi-bidirectional ports
4. Ordering information section: AT89C5122DS part-numbers added

Changes from 4202D to 4202E

1. Changed input voltage frequency from 3.6V to 3.0V throughout the document.
2. Update of DC parameters of smart card interface to be EMV 4.1 compliant.

Changes from 4202E to 4202F

1. Product AT83EC5122 and AT83EC5123 removed.
2. Product AT83R5122 added.
3. Package PLCC28 not supported anymore.
4. Global update.

Table of Contents

Features	1
Reference Documents	2
Product Description	3
AT8xC5122/AT83R5122 Block Diagram	4
AT83C5123 Block Diagram	4
Pinout	5
High Pin Count Package Description.....	5
Low Pin Count Package Description	10
Pin Description.....	11
Typical Applications	15
Recommended External components	15
USB Keyboard with Smart Card Reader Using AT83R5122, AT8xC5122/AT89C5122DS	16
USB Smart Card Reader Using the AT83C5123 Version.....	17
Memory Organization	18
Program Memory Management.....	18
Data Memory Management	19
Dual Data Pointer Register (DDPTR)	20
Registers.....	22
AT8xC5122's CRAM and E2PROM Versions	24
AT83R5122, AT8xC5122's ROM Version	28
AT83C5123 Version	30
Special Function Registers (SFR's)	31
Introduction	31
AT8xC5122 Version.....	32
AT83C5123 Version	33
SFR's Description	34
Clock Controller	39
On-Chip Oscillator	39
Phase Lock Loop (PLL)	40
Clock Tree Architecture	41
Registers.....	48
I/O Port Definition	51
Port Configuration.....	55
Registers.....	59
Smart Card Interface Block (SCIB)	62
Block Diagram	63



Definitions	63
Functional Description	65
Additional Features	72
Alternate Card	76
Registers	76
DC/DC Converter	86
USB Controller	93
Description	94
Configuration	97
Read/Write Data FIFO	100
Bulk / Interrupt Transactions	101
Control Transactions	105
Isochronous Transactions	106
Miscellaneous	108
Suspend/Resume Management	109
Detach Simulation	112
USB Interrupt System	113
Registers	115
Serial I/O Port	124
Framing Error Detection	124
Automatic Address Recognition	125
Asynchronous Modes (Modes 1, 2 and 3)	129
Modes 2 and 3	130
Registers	133
Serial Port Interface (SPI)	135
Features	135
Signal Description	135
Functional Description	137
Timers/Counters	145
Timer/Counter Operations	145
Timer 0	145
Timer 1	148
Registers	150
Keyboard Interface	153
Introduction	153
Description	153
Registers	154
Interrupt System	157
Introduction	157
Interrupt System Description	157

Registers.....	160
Interrupt Sources and Vectors	169
Microcontroller Reset	170
Introduction	170
Power On Reset (POR)	171
Power Fail Detector (PFD).....	171
Reset pin.....	173
Watchdog Timer	175
Power Management	178
Idle Mode	178
Power Down Mode	178
Reduced EMI Mode	179
USB Interface	180
Smart Card Interface	181
Keyboard Interface	182
Watchdog Timer during Power-down and Idle Mode.....	182
Registers.....	183
Electrical Characteristics	184
Absolute Maximum Ratings	184
DC Parameters	184
LED's	186
Smart Card Interface	187
USB Interface	190
AC Parameters	191
Float Waveforms.....	197
Packaging Information	199
Ordering Information.....	199
Datasheet Revision History	204
Changes from 4202A to 4202B	204
Changes from 4202B to 4202C	204
Changes from 4202C to 4202D	204
Changes from 4202D to 4202E	204
Changes from 4202E to 4202F	204
Table of Contents	205



Atmel Corporation

2325 Orchard Parkway
San Jose, CA 95131, USA
Tel: 1(408) 441-0311
Fax: 1(408) 487-2600

Regional Headquarters

Europe

Atmel Sarl
Route des Arsenaux 41
Case Postale 80
CH-1705 Fribourg
Switzerland
Tel: (41) 26-426-5555
Fax: (41) 26-426-5500

Asia

Room 1219
Chinachem Golden Plaza
77 Mody Road Tsimshatsui
East Kowloon
Hong Kong
Tel: (852) 2721-9778
Fax: (852) 2722-1369

Japan

9F, Tonetsu Shinkawa Bldg.
1-24-8 Shinkawa
Chuo-ku, Tokyo 104-0033
Japan
Tel: (81) 3-3523-3551
Fax: (81) 3-3523-7581

Atmel Operations

Memory

2325 Orchard Parkway
San Jose, CA 95131, USA
Tel: 1(408) 441-0311
Fax: 1(408) 436-4314

Microcontrollers

2325 Orchard Parkway
San Jose, CA 95131, USA
Tel: 1(408) 441-0311
Fax: 1(408) 436-4314

La Chantrerie
BP 70602
44306 Nantes Cedex 3, France
Tel: (33) 2-40-18-18-18
Fax: (33) 2-40-18-19-60

ASIC/ASSP/Smart Cards

Zone Industrielle
13106 Rousset Cedex, France
Tel: (33) 4-42-53-60-00
Fax: (33) 4-42-53-60-01

1150 East Cheyenne Mtn. Blvd.
Colorado Springs, CO 80906, USA
Tel: 1(719) 576-3300
Fax: 1(719) 540-1759

Scottish Enterprise Technology Park
Maxwell Building
East Kilbride G75 0QR, Scotland
Tel: (44) 1355-803-000
Fax: (44) 1355-242-743

RF/Automotive

Theresienstrasse 2
Postfach 3535
74025 Heilbronn, Germany
Tel: (49) 71-31-67-0
Fax: (49) 71-31-67-2340

1150 East Cheyenne Mtn. Blvd.
Colorado Springs, CO 80906, USA
Tel: 1(719) 576-3300
Fax: 1(719) 540-1759

Biometrics/Imaging/Hi-Rel MPU/ High Speed Converters/RF Datacom

Avenue de Rochepleine
BP 123
38521 Saint-Egreve Cedex, France
Tel: (33) 4-76-58-30-00
Fax: (33) 4-76-58-34-80

Literature Requests

www.atmel.com/literature

Disclaimer: The information in this document is provided in connection with Atmel products. No license, express or implied, by estoppel or otherwise, to any intellectual property right is granted by this document or in connection with the sale of Atmel products. **EXCEPT AS SET FORTH IN ATMEL'S TERMS AND CONDITIONS OF SALE LOCATED ON ATMEL'S WEB SITE, ATMEL ASSUMES NO LIABILITY WHATSOEVER AND DISCLAIMS ANY EXPRESS, IMPLIED OR STATUTORY WARRANTY RELATING TO ITS PRODUCTS INCLUDING, BUT NOT LIMITED TO, THE IMPLIED WARRANTY OF MERCHANTABILITY, FITNESS FOR A PARTICULAR PURPOSE, OR NON-INFRINGEMENT. IN NO EVENT SHALL ATMEL BE LIABLE FOR ANY DIRECT, INDIRECT, CONSEQUENTIAL, PUNITIVE, SPECIAL OR INCIDENTAL DAMAGES (INCLUDING, WITHOUT LIMITATION, DAMAGES FOR LOSS OF PROFITS, BUSINESS INTERRUPTION, OR LOSS OF INFORMATION) ARISING OUT OF THE USE OR INABILITY TO USE THIS DOCUMENT, EVEN IF ATMEL HAS BEEN ADVISED OF THE POSSIBILITY OF SUCH DAMAGES.** Atmel makes no representations or warranties with respect to the accuracy or completeness of the contents of this document and reserves the right to make changes to specifications and product descriptions at any time without notice. Atmel does not make any commitment to update the information contained herein. Unless specifically provided otherwise, Atmel products are not suitable for, and shall not be used in, automotive applications. Atmel's products are not intended, authorized, or warranted for use as components in applications intended to support or sustain life.

© Atmel Corporation 2006. All rights reserved. Atmel®, logo and combinations thereof, are registered trademarks, and Everywhere You Are® are the trademarks of Atmel Corporation or its subsidiaries. Other terms and product names may be trademarks of others.



Printed on recycled paper.



4202F-SCR-07/2008

Looking for pricing, stock, or lifecycle information?

Click below to explore more details on WIN SOURCE:

-  [View AT89C5122D-RDVIM on WIN SOURCE](#)
-  [Atmel Information](#)

Optimize Your Supply Chain with WIN SOURCE Solutions

-  Global Sourcing Solution
-  Obsolete Management
-  Cost Control Management
-  Shortage Management
-  Alternative Solution
-  Excess Inventory Management