



**THE DATASHEET OF
AT89C1051U-24SC**



Features

- Compatible with MCS-51™ Products
- 1K Bytes of Reprogrammable Flash Memory
 - Endurance: 1,000 Write/Erase Cycles
- 2.7V to 6V Operating Range
- Fully Static Operation: 0 Hz to 24 MHz
- Two-level Program Memory Lock
- 64 x 8-bit Internal RAM
- 15 Programmable I/O Lines
- Two 16-bit Timer/Counters
- Six Interrupt Sources
- Programmable Serial UART Channel
- Direct LED Drive Outputs
- On-chip Analog Comparator
- Low-power Idle and Power-down Modes

Description

The AT89C1051U is a low-voltage, high-performance CMOS 8-bit microcomputer with 1K byte of Flash programmable and erasable read only memory. It has the same functionality and operation as the AT89C1051 with the addition of a UART programmable serial port. The device is manufactured using Atmel's high-density nonvolatile memory technology and is compatible with the industry-standard MCS-51 instruction set. By combining a versatile 8-bit CPU with Flash on a monolithic chip, the Atmel AT89C1051U is a powerful microcomputer which provides a highly-flexible and cost-effective solution to many embedded control applications.

The AT89C1051U provides the following standard features: 1K byte of Flash, 64 bytes of RAM, 15 I/O lines, two 16-bit timer/counters, a five-vector, two-level interrupt architecture, a full duplex serial port, a precision analog comparator, on-chip oscillator and clock circuitry. In addition, the AT89C1051U is designed with static logic for operation down to zero frequency and supports two software-selectable power saving modes. The Idle Mode stops the CPU while allowing the RAM, timer/counters, serial port and interrupt system to continue functioning. The power-down mode saves the RAM contents but freezes the oscillator disabling all other chip functions until the next hardware reset.

Pin Configuration

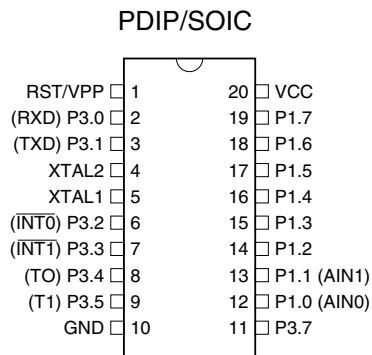

8-bit Microcontroller with 1K Byte Flash

AT89C1051U



Block Diagram

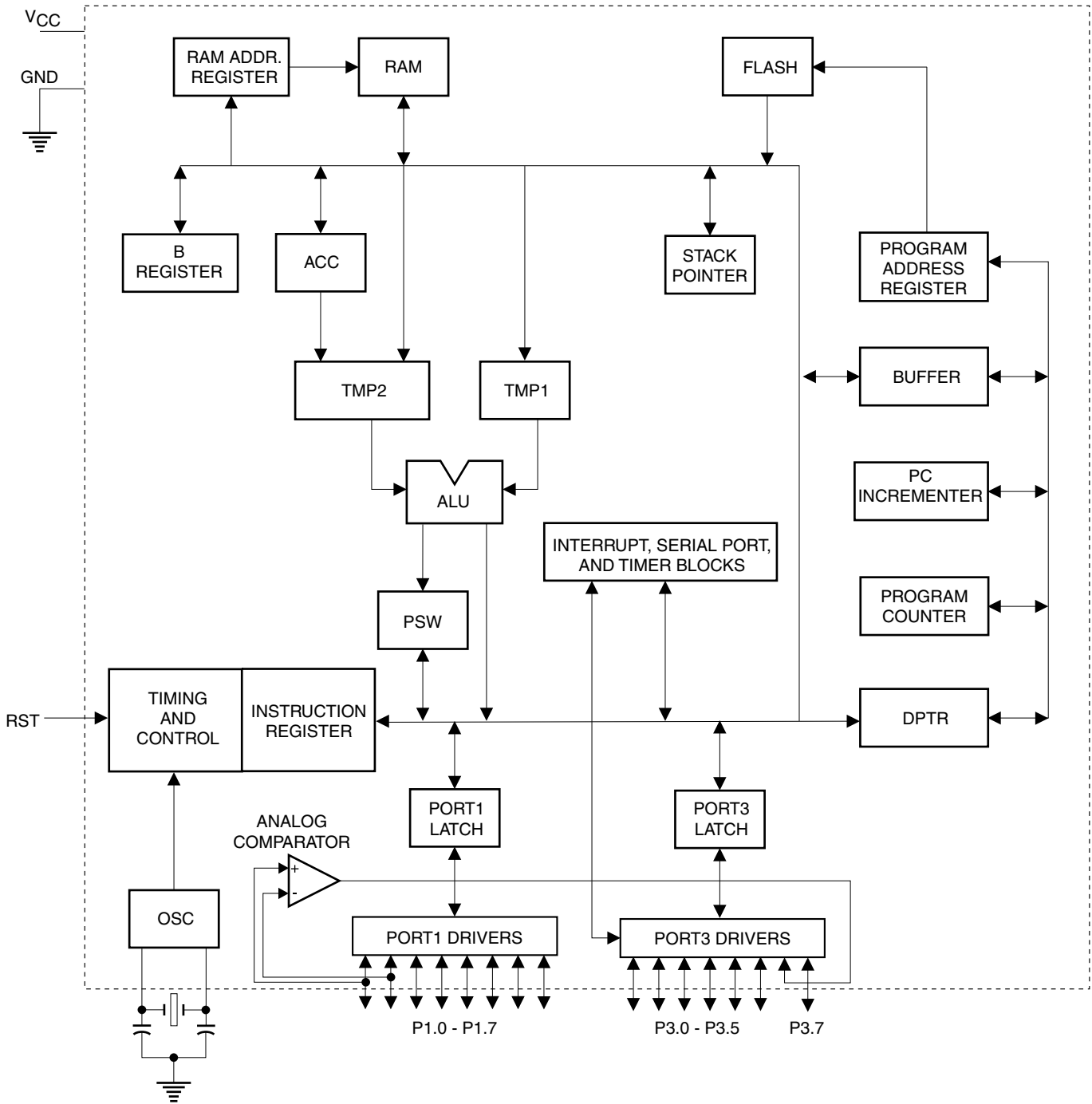

Pin Description

VCC

Supply voltage.

GND

Ground.

Port 1

Port 1 is an 8-bit bidirectional I/O port. Port pins P1.2 to P1.7 provide internal pullups. P1.0 and P1.1 require external pullups. P1.0 and P1.1 also serve as the positive input (AIN0) and the negative input (AIN1), respectively, of the on-chip precision analog comparator. The Port 1 output buffers can sink 20 mA and can drive LED displays directly. When 1s are written to Port 1 pins, they can be used as inputs. When pins P1.2 to P1.7 are used as inputs and are externally pulled low, they will source current (I_{IL}) because of the internal pullups.

Port 1 also receives code data during Flash programming and verification.

Port 3

Port 3 pins P3.0 to P3.5, P3.7 are seven bidirectional I/O pins with internal pullups. P3.6 is hard-wired as an input to the output of the on-chip comparator and is not accessible as a general purpose I/O pin. The Port 3 output buffers can sink 20 mA. When 1s are written to Port 3 pins they are pulled high by the internal pullups and can be used as inputs. As inputs, Port 3 pins that are externally being pulled low will source current (I_{IL}) because of the pullups.

Port 3 also serves the functions of various special features of the AT89C1051U as listed below:

Port Pin	Alternate Functions
P3.0	RXD (serial input port)
P3.1	TXD (serial output port)
P3.2	$\overline{INT0}$ (external interrupt 0)
P3.3	$\overline{INT1}$ (external interrupt 1)
P3.4	T0 (timer 0 external input)
P3.5	T1 (timer 1 external input)

Port 3 also receives some control signals for Flash programming and verification.

RST

Reset input. All I/O pins are reset to 1s as soon as RST goes high. Holding the RST pin high for two machine cycles while the oscillator is running resets the device.

Each machine cycle takes 12 oscillator or clock cycles.

XTAL1

Input to the inverting oscillator amplifier and input to the internal clock operating circuit.

XTAL2

Output from the inverting oscillator amplifier.

Oscillator Characteristics

XTAL1 and XTAL2 are the input and output, respectively, of an inverting amplifier which can be configured for use as an on-chip oscillator, as shown in Figure 1. Either a quartz crystal or ceramic resonator may be used. To drive the device from an external clock source, XTAL2 should be left unconnected while XTAL1 is driven as shown in Figure 2. There are no requirements on the duty cycle of the external clock signal, since the input to the internal clocking circuitry is through a divide-by-two flip-flop, but minimum and maximum voltage high and low time specifications must be observed.

Figure 1. Oscillator Connections

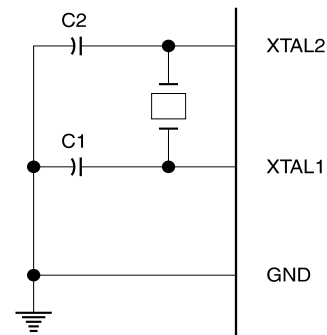

Note: C1, C2 = 30 pF ± 10 pF for Crystals
= 40 pF ± 10 pF for Ceramic Resonators

Figure 2. External Clock Drive Configuration

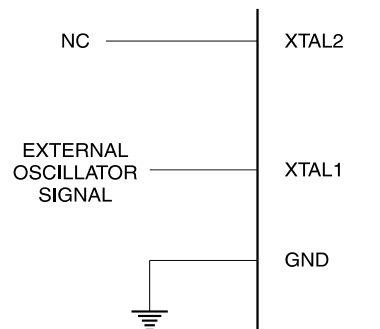



Special Function Registers

A map of the on-chip memory area called the Special Function Register (SFR) space is shown in the table below.

Note that not all of the addresses are occupied, and unoccupied addresses may not be implemented on the chip. Read accesses to these addresses will in general return random data, and write accesses will have an indeterminate effect.

User software should not write 1s to these unlisted locations, since they may be used in future products to invoke new features. In that case, the reset or inactive values of the new bits will always be 0.

Table 1. AT89C1051U SFR Map and Reset Values

0F8H								0FFH
0F0H	B 00000000							0F7H
0E8H								0EFH
0E0H	ACC 00000000							0E7H
0D8H								0DFH
0D0H	PSW 00000000							0D7H
0C8H								0CFH
0C0H								0C7H
0B8H	IP XXX00000							0BFH
0B0H	P3 11111111							0B7H
0A8H	IE 0XX00000							0AFH
0A0H								0A7H
98H	SCON 00000000	SBUF XXXXXXXX						9FH
90H	P1 11111111							97H
88H	TCON 00000000	TMOD 00000000	TL0 00000000	TL1 00000000	TH0 00000000	TH1 00000000		8FH
80H		SP 00000111	DPL 00000000	DPH 00000000			PCON 0XXX0000	87H

Restrictions on Certain Instructions

The AT89C1051U and is an economical and cost-effective member of Atmel's growing family of microcontrollers. It contains 1K byte of flash program memory. It is fully compatible with the MCS-51 architecture, and can be programmed using the MCS-51 instruction set. However, there are a few considerations one must keep in mind when utilizing certain instructions to program this device.

All the instructions related to jumping or branching should be restricted such that the destination address falls within the physical program memory space of the device, which is 1K for the AT89C1051U. This should be the responsibility of the software programmer. For example, LJMP 3FEH would be a valid instruction for the AT89C1051U (with 1K of memory), whereas LJMP 410H would not.

1. Branching instructions:

LCALL, LJMP, ACALL, AJMP, SJMP, JMP @A+DPTR.

These unconditional branching instructions will execute correctly as long as the programmer keeps in mind that the destination branching address must fall within the physical boundaries of the program memory size (locations 00H to 3FFH for the 89C1051U). Violating the physical space limits may cause unknown program behavior.

CJNE [...], DJNZ [...], JB, JNB, JC, JNC, JBC, JZ, JNZ With these conditional branching instructions the same rule above applies. Again, violating the memory boundaries may cause erratic execution.

For applications involving interrupts the normal interrupt service routine address locations of the 80C51 family architecture have been preserved.

2. MOVX-related instructions, Data Memory:

The AT89C1051U contains 64 bytes of internal data memory. Thus, in the AT89C1051U the stack depth is limited to 64 bytes, the amount of available RAM. External DATA memory access is not supported in this device, nor is external PROGRAM memory execution. Therefore, no MOVX [...] instructions should be included in the program.

A typical 80C51 assembler will still assemble instructions, even if they are written in violation of the restrictions mentioned above. It is the responsibility of the controller user to know the physical features and limitations of the device being used and adjust the instructions used correspondingly.

Programmable Serial UART Channel⁽¹⁾

The AT89C1051U offers a programmable serial port which is compatible with the serial ports on other AT89 series flash MCU products. A detailed description of the serial port

operation can be found in the Hardware Description section of the Atmel AT89 series flash MCU data book.

Note: 1. This feature is not available on the AT89C1051.

Program Memory Lock Bits

On the chip are two lock bits which can be left unprogrammed (U) or can be programmed (P) to obtain the additional features listed in the table below:

Lock Bit Protection Modes⁽¹⁾

Program Lock Bits			Protection Type
	LB1	LB2	
1	U	U	No program lock features.
2	P	U	Further programming of the Flash is disabled.
3	P	P	Same as mode 2, also verify is disabled.

Note: 1. The Lock Bits can only be erased with the Chip Erase operation.

Idle Mode

In idle mode, the CPU puts itself to sleep while all the on-chip peripherals remain active. The mode is invoked by software. The content of the on-chip RAM and all the special functions registers remain unchanged during this mode. The idle mode can be terminated by any enabled interrupt or by a hardware reset.

P1.0 and P1.1 should be set to "0" if no external pullups are used, or set to "1" if external pullups are used.

It should be noted that when idle is terminated by a hardware reset, the device normally resumes program execution, from where it left off, up to two machine cycles before the internal reset algorithm takes control. On-chip hardware inhibits access to internal RAM in this event, but access to the port pins is not inhibited. To eliminate the possibility of an unexpected write to a port pin when Idle is terminated by reset, the instruction following the one that invokes Idle should not be one that writes to a port pin or to external memory.

Power-down Mode

In the power-down mode the oscillator is stopped, and the instruction that invokes power-down is the last instruction executed. The on-chip RAM and Special Function Registers retain their values until the power-down mode is terminated. The only exit from power-down is a hardware reset. Reset redefines the SFRs but does not change the on-chip RAM. The reset should not be activated before V_{CC}

is restored to its normal operating level and must be held active long enough to allow the oscillator to restart and stabilize.

P1.0 and P1.1 should be set to “0” if no external pullups are used, or set to “1” if external pullups are used.

Programming The Flash

The AT89C1051U is shipped with the 1K byte of on-chip PEROM code memory array in the erased state (i.e., contents = FFH) and ready to be programmed. The code memory array is programmed one byte at a time. Once the array is programmed, to re-program any non-blank byte, the entire memory array needs to be erased electrically.

Internal Address Counter: The AT89C1051U contains an internal PEROM address counter which is always reset to 000H on the rising edge of RST and is advanced by applying a positive going pulse to pin XTAL1.

Programming Algorithm: To program the AT89C1051U, the following sequence is recommended.

1. Power-up sequence:
Apply power between V_{CC} and GND pins
Set RST and XTAL1 to GND
 2. Set pin RST to “H”
Set pin P3.2 to “H”
 3. Apply the appropriate combination of “H” or “L” logic levels to pins P3.3, P3.4, P3.5, P3.7 to select one of the programming operations shown in the PEROM Programming Modes table.
- To Program and Verify the Array:
4. Apply data for Code byte at location 000H to P1.0 to P1.7.
 5. Raise RST to 12V to enable programming.
 6. Pulse P3.2 once to program a byte in the PEROM array or the lock bits. The byte-write cycle is self-timed and typically takes 1.2 ms.
 7. To verify the programmed data, lower RST from 12V to logic “H” level and set pins P3.3 to P3.7 to the appropriate levels. Output data can be read at the port P1 pins.
 8. To program a byte at the next address location, pulse XTAL1 pin once to advance the internal address counter. Apply new data to the port P1 pins.
 9. Repeat steps 5 through 8, changing data and advancing the address counter for the entire 1K byte array or until the end of the object file is reached.
 10. Power-off sequence:
set XTAL1 to “L”
set RST to “L”
Turn V_{CC} power off

Data Polling: The AT89C1051U features $\overline{\text{Data}}$ Polling to indicate the end of a write cycle. During a write cycle, an attempted read of the last byte written will result in the complement of the written data on P1.7. Once the write cycle has been completed, true $\overline{\text{data}}$ is valid on all outputs, and the next cycle may begin. $\overline{\text{Data}}$ Polling may begin any time after a write cycle has been initiated.

Ready/Busy: The Progress of byte programming can also be monitored by the RDY/ $\overline{\text{BSY}}$ output signal. Pin P3.1 is pulled low after P3.2 goes High during programming to indicate BUSY. P3.1 is pulled High again when programming is done to indicate READY.

Program Verify: If lock bits LB1 and LB2 have not been programmed code data can be read back via the data lines for verification:

1. Reset the internal address counter to 000H by bringing RST from “L” to “H”.
2. Apply the appropriate control signals for Read Code data and read the output data at the port P1 pins.
3. Pulse pin XTAL1 once to advance the internal address counter.
4. Read the next code data byte at the port P1 pins.
5. Repeat steps 3 and 4 until the entire array is read.

The lock bits cannot be verified directly. Verification of the lock bits is achieved by observing that their features are enabled.

Chip Erase: The entire PEROM array (1K byte) and the two Lock Bits are erased electrically by using the proper combination of control signals and by holding P3.2 low for 10 ms. The code array is written with all “1”s in the Chip Erase operation and must be executed before any non-blank memory byte can be re-programmed.

Reading the Signature Bytes: The signature bytes are read by the same procedure as a normal verification of locations 000H, 001H, and 002H, except that P3.5 and P3.7 must be pulled to a logic low. The values returned are as follows.

(000H) = 1EH indicates manufactured by Atmel

(001H) = 12H indicates 89C1051U

Programming Interface

Every code byte in the Flash array can be written and the entire array can be erased by using the appropriate combination of control signals. The write operation cycle is self-timed and once initiated, will automatically time itself to completion.

All major programming vendors offer worldwide support for the Atmel microcontroller series. Please contact your local programming vendor for the appropriate software revision.

Flash Programming Modes

Mode		RST/VPP	P3.2/ $\overline{\text{PROG}}$	P3.3	P3.4	P3.5	P3.7
Write Code Data ⁽¹⁾⁽³⁾		12V		L	H	H	H
Read Code Data ⁽¹⁾		H	H	L	L	H	H
Write Lock	Bit - 1	12V		H	H	H	H
	Bit - 2	12V		H	H	L	L
Chip Erase		12V		H	L	L	L
Read Signature Byte		H	H	L	L	L	L

- Notes:
1. The internal PEROM address counter is reset to 000H on the rising edge of RST and is advanced by a positive pulse at XTAL1 pin.
 2. Chip Erase requires a 10-ms $\overline{\text{PROG}}$ pulse.
 3. P3.1 is pulled Low during programming to indicate RDY/ $\overline{\text{BSY}}$.

Figure 3. Programming the Flash Memory

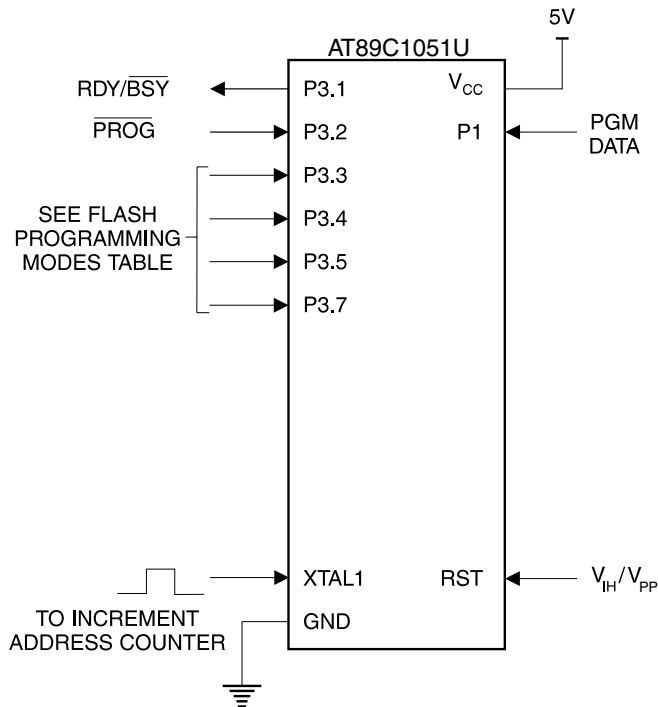
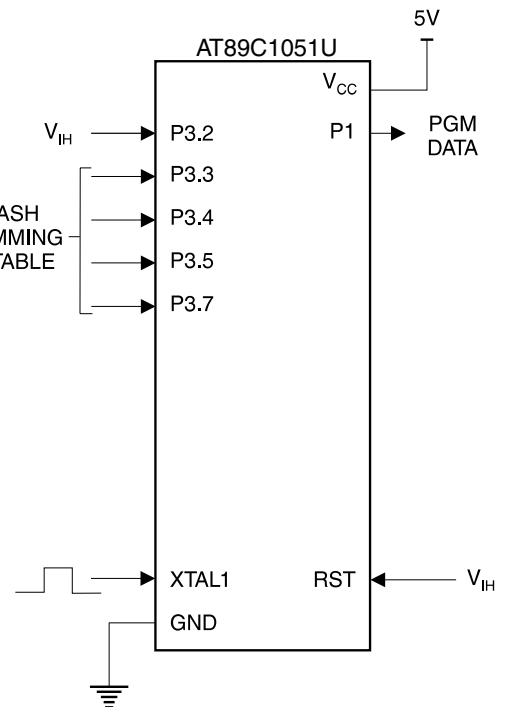

Figure 4. Verifying the Flash Memory





Flash Programming and Verification Characteristics

$T_A = 0^\circ\text{C}$ to 70°C , $V_{CC} = 5.0 \pm 10\%$

Symbol	Parameter	Min	Max	Units
V_{PP}	Programming Enable Voltage	11.5	12.5	V
I_{PP}	Programming Enable Current		250	μA
t_{DVGL}	Data Setup to $\overline{\text{PROG}}$ Low	1.0		μs
t_{GHDX}	Data Hold after $\overline{\text{PROG}}$	1.0		μs
t_{EHS}	P3.4 ($\overline{\text{ENABLE}}$) High to V_{PP}	1.0		μs
t_{SHGL}	V_{PP} Setup to $\overline{\text{PROG}}$ Low	10		μs
t_{GHSL}	V_{PP} Hold after $\overline{\text{PROG}}$	10		μs
t_{GLGH}	$\overline{\text{PROG}}$ Width	1	110	μs
t_{ELQV}	$\overline{\text{ENABLE}}$ Low to Data Valid		1.0	μs
t_{EHQZ}	Data Float after $\overline{\text{ENABLE}}$	0	1.0	μs
t_{GHBL}	$\overline{\text{PROG}}$ High to $\overline{\text{BUSY}}$ Low		50	ns
t_{WC}	Byte Write Cycle Time		2.0	ms
t_{BHIH}	$\text{RDY}/\overline{\text{BSY}}$ to Increment Clock Delay	1.0		μs
t_{IHIL}	Increment Clock High	200		ns

Flash Programming and Verification Waveforms

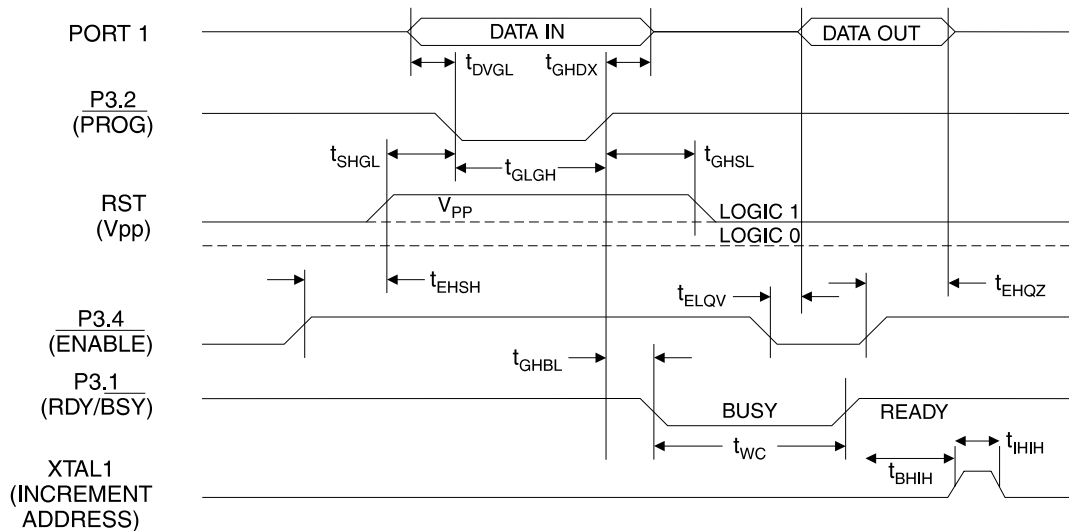

Absolute Maximum Ratings*

Operating Temperature	-55°C to +125°C
Storage Temperature	-65°C to +150°C
Voltage on Any Pin with Respect to Ground	-1.0V to +7.0V
Maximum Operating Voltage	6.6V
DC Output Current.....	25.0 mA

*NOTICE: Stresses beyond those listed under “Absolute Maximum Ratings” may cause permanent damage to the device. This is a stress rating only and functional operation of the device at these or any other conditions beyond those indicated in the operational sections of this specification is not implied. Exposure to absolute maximum rating conditions for extended periods may affect device reliability.

DC Characteristics

T_A = -40°C to 85°C, V_{CC} = 2.7V to 6.0V (unless otherwise noted)

Symbol	Parameter	Condition	Min	Max	Units
V _{IL}	Input Low-voltage		-0.5	0.2 V _{CC} - 0.1	V
V _{IH}	Input High-voltage	(Except XTAL1, RST)	0.2 V _{CC} + 0.9	V _{CC} + 0.5	V
V _{IH1}	Input High-voltage	(XTAL1, RST)	0.7 V _{CC}	V _{CC} + 0.5	V
V _{OL}	Output Low-voltage ⁽¹⁾ (Ports 1, 3)	I _{OL} = 20 mA, V _{CC} = 5V I _{OL} = 10 mA, V _{CC} = 2.7V		0.5	V
V _{OH}	Output High-voltage (Ports 1, 3)	I _{OH} = -80 μA, V _{CC} = 5V ± 10%	2.4		V
		I _{OH} = -30 μA	0.75 V _{CC}		V
		I _{OH} = -12 μA	0.9 V _{CC}		V
I _{IL}	Logical 0 Input Current (Ports 1, 3)	V _{IN} = 0.45V		-50	μA
I _{TL}	Logical 1 to 0 Transition Current (Ports 1, 3)	V _{IN} = 2V, V _{CC} = 5V ± 10%		-750	μA
I _{LI}	Input Leakage Current (Port P1.0, P1.1)	0 < V _{IN} < V _{CC}		±10	μA
V _{OS}	Comparator Input Offset Voltage	V _{CC} = 5V		20	mV
V _{CM}	Comparator Input Common Mode Voltage		0	V _{CC}	V
RRST	Reset Pulldown Resistor		50	300	KΩ
C _{IO}	Pin Capacitance	Test Freq. = 1 MHz, T _A = 25°C		10	pF
I _{CC}	Power Supply Current	Active Mode, 12 MHz, V _{CC} = 6V/3V		15/5.5	mA
		Idle Mode, 12 MHz, V _{CC} = 6V/3V P1.0 & P1.1 = 0V or V _{CC}		5/1	mA
	Power-down Mode ⁽²⁾	V _{CC} = 6V P1.0 & P1.1 = 0V or V _{CC}		100	μA
		V _{CC} = 3V P1.0 & P1.1 = 0V or V _{CC}		20	μA

Notes: 1. Under steady state (non-transient) conditions, I_{OL} must be externally limited as follows:

Maximum I_{OL} per port pin: 20 mA

Maximum total I_{OL} for all output pins: 80 mA

If I_{OL} exceeds the test condition, V_{OL} may exceed the related specification. Pins are not guaranteed to sink current greater than the listed test conditions.

2. Minimum V_{CC} for Power-down is 2V.

External Clock Drive Waveforms

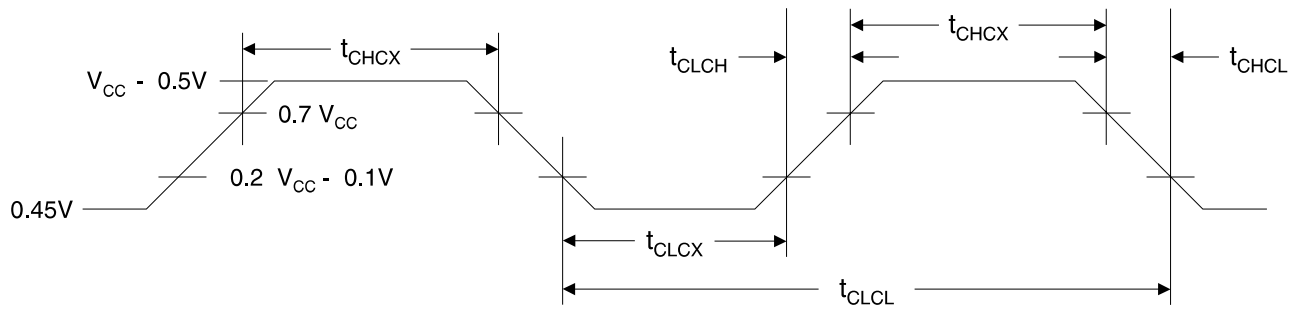

External Clock Drive

Symbol	Parameter	$V_{CC} = 2.7V \text{ to } 6.0V$		$V_{CC} = 4.0V \text{ to } 6.0V$		Units
		Min	Max	Min	Max	
$1/t_{CLCL}$	Oscillator Frequency	0	12	0	24	MHz
t_{CLCL}	Clock Period	83.3		41.6		ns
t_{CHCX}	High Time	30		15		ns
t_{CLCX}	Low Time	30		15		ns
t_{CLCH}	Rise Time		20		20	ns
t_{CHCL}	Fall Time		20		20	ns

Serial Port Timing: Shift Register Mode Test Conditions

$V_{CC} = 5.0V \pm 20\%$; Load Capacitance = 80 pF

Symbol	Parameter	12 MHz Osc		Variable Oscillator		Units
		Min	Max	Min	Max	
t_{XLXL}	Serial Port Clock Cycle Time	1.0		$12t_{CLCL}$		μs
t_{QVXH}	Output Data Setup to Clock Rising Edge	700		$10t_{CLCL}-133$		ns
t_{XHGX}	Output Data Hold after Clock Rising Edge	50		$2t_{CLCL}-117$		ns
t_{XHDX}	Input Data Hold after Clock Rising Edge	0		0		ns
t_{XHDX}	Clock Rising Edge to Input Data Valid		700		$10t_{CLCL}-133$	ns

Shift Register Mode Timing Waveforms

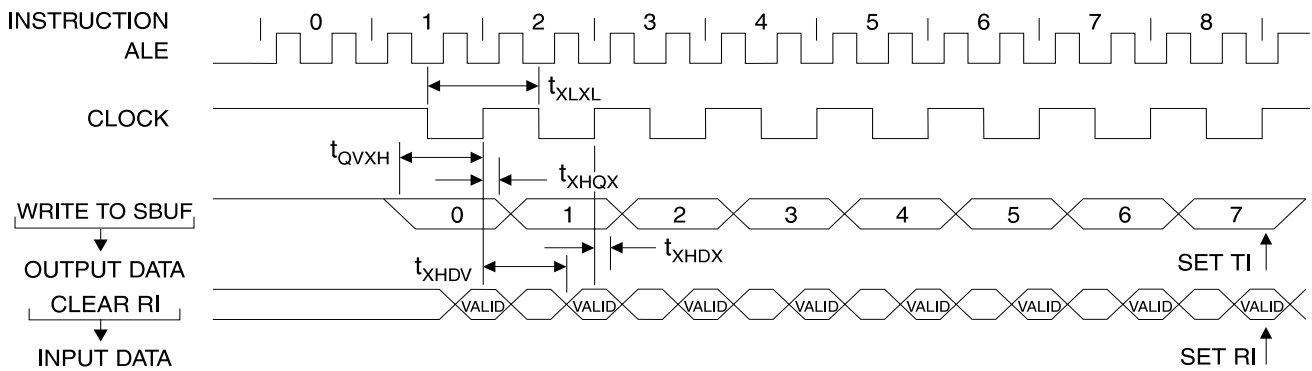

AC Testing Input/Output Waveforms⁽¹⁾

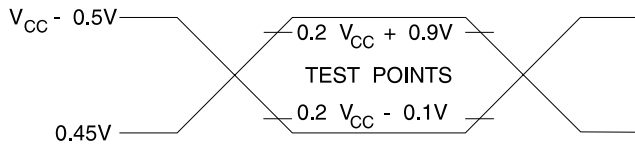

Note: 1. AC Inputs during testing are driven at $V_{CC} - 0.5V$ for a logic 1 and $0.45V$ for a logic 0. Timing measurements are made at V_{IH} min. for a logic 1 and V_{IL} max. for a logic 0.

Float Waveforms⁽¹⁾

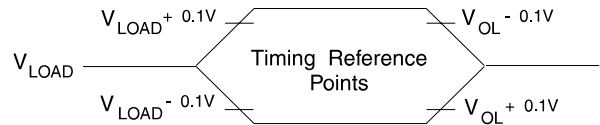

Note: 1. For timing purposes, a port pin is no longer floating when a 100 mV change from load voltage occurs. A port pin begins to float when 100 mV change from the loaded V_{OH}/V_{OL} level occurs.

AT89C1051U
TYPICAL I_{CC} - ACTIVE (85°C)

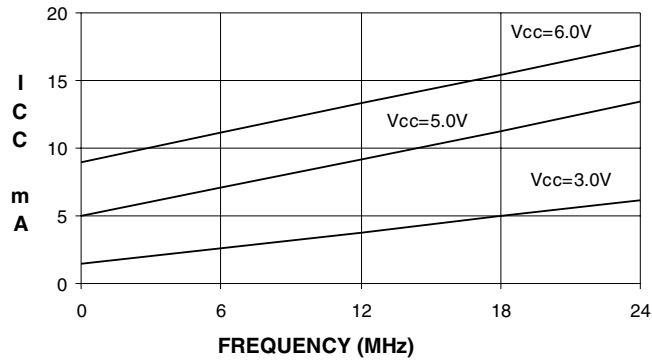

AT89C1051U
TYPICAL I_{CC} - IDLE (85°C)

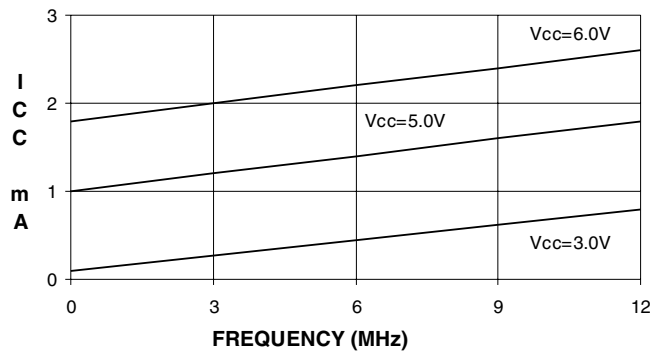

AT89C1051U
TYPICAL I_{CC} vs. VOLTAGE- POWER DOWN (85°C)

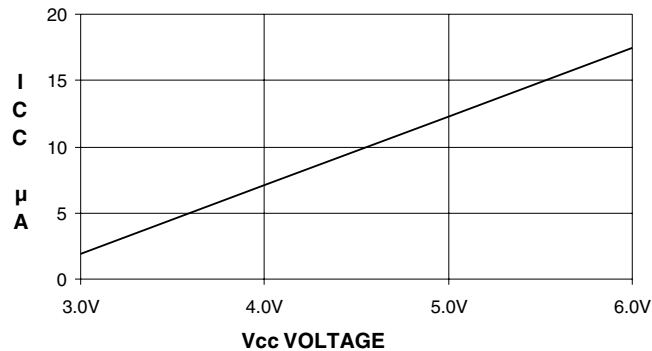

- Notes:
1. XTAL1 tied to GND for I_{CC} (power-down)
 2. P.1.0 and P.1.1 = V_{CC} or GND
 3. Lock bits programmed

Ordering Information

Speed (MHz)	Power Supply	Ordering Code	Package	Operation Range
12	2.7V to 6.0V	AT89C1051U-12PC AT89C1051U-12SC	20P3 20S	Commercial (0°C to 70°C)
		AT89C1051U-12PI AT89C1051U-12SI	20P3 20S	Industrial (-40°C to 85°C)
24	4.0V to 6.0V	AT89C1051U-24PC AT89C1051U-24SC	20P3 20S	Commercial (0°C to 70°C)
		AT89C1051U-24PI AT89C1051U-24SI	20P3 20S	Industrial (-40°C to 85°C)

Package Type	
20P3	20-lead, 0.300" Wide, Plastic Dual In-line Package (PDIP)
20S	20-lead, 0.300" Wide, Plastic Gull Wing Small Outline (SOIC)

Packaging Information

20P3, 20-lead, 0.300" Wide,
Plastic Dual In-line Package (PDIP)
Dimensions in Inches and (Millimeters)
JEDEC STANDARD MS-001 AD

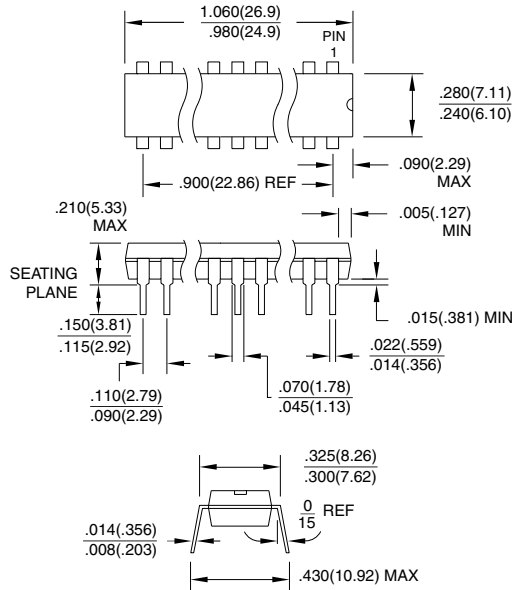

20S, 20-lead, 0.300" Wide,
Plastic Gull Wing Small Outline (SOIC)
Dimensions in Inches and (Millimeters)

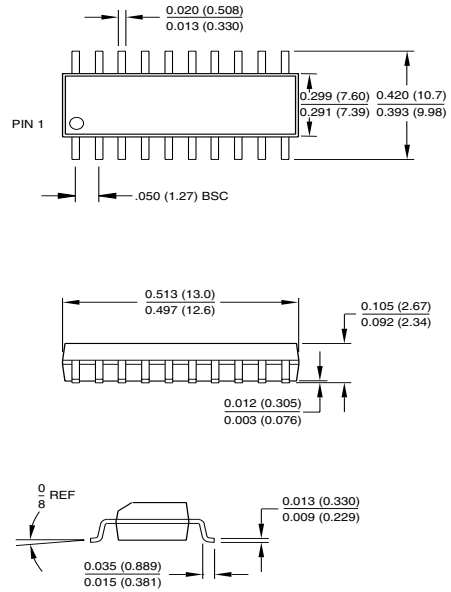



Atmel Headquarters

Corporate Headquarters

2325 Orchard Parkway
San Jose, CA 95131
TEL (408) 441-0311
FAX (408) 487-2600

Europe

Atmel U.K., Ltd.
Coliseum Business Centre
Riverside Way
Camberley, Surrey GU15 3YL
England
TEL (44) 1276-686-677
FAX (44) 1276-686-697

Asia

Atmel Asia, Ltd.
Room 1219
Chinachem Golden Plaza
77 Mody Road Tsimhatsui
East Kowloon
Hong Kong
TEL (852) 2721-9778
FAX (852) 2722-1369

Japan

Atmel Japan K.K.
9F, Tonetsu Shinkawa Bldg.
1-24-8 Shinkawa
Chuo-ku, Tokyo 104-0033
Japan
TEL (81) 3-3523-3551
FAX (81) 3-3523-7581

Atmel Operations

Atmel Colorado Springs

1150 E. Cheyenne Mtn. Blvd.
Colorado Springs, CO 80906
TEL (719) 576-3300
FAX (719) 540-1759

Atmel Rousset

Zone Industrielle
13106 Rousset Cedex
France
TEL (33) 4-4253-6000
FAX (33) 4-4253-6001

Fax-on-Demand

North America:
1-(800) 292-8635
International:
1-(408) 441-0732

e-mail

literature@atmel.com

Web Site

<http://www.atmel.com>

BBS

1-(408) 436-4309

© Atmel Corporation 1999.

Atmel Corporation makes no warranty for the use of its products, other than those expressly contained in the Company's standard warranty which is detailed in Atmel's Terms and Conditions located on the Company's web site. The Company assumes no responsibility for any errors which may appear in this document, reserves the right to change devices or specifications detailed herein at any time without notice, and does not make any commitment to update the information contained herein. No licenses to patents or other intellectual property of Atmel are granted by the Company in connection with the sale of Atmel products, expressly or by implication. Atmel's products are not authorized for use as critical components in life support devices or systems.

Marks bearing ® and/or ™ are registered trademarks and trademarks of Atmel Corporation.

Terms and product names in this document may be trademarks of others.



Printed on recycled paper.

1045C-02/00/xM

Looking for pricing, stock, or lifecycle information?

Click below to explore more details on WIN SOURCE:

 [View AT89C1051U-24SC on WIN SOURCE](#)

 [Atmel Information](#)

Optimize Your Supply Chain with WIN SOURCE Solutions

-  Global Sourcing Solution
-  Obsolete Management
-  Cost Control Management
-  Shortage Management
-  Alternative Solution
-  Excess Inventory Management