

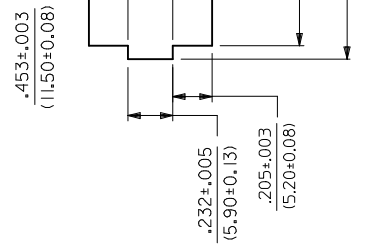

**THE DATASHEET OF**  
**15-06-0146**

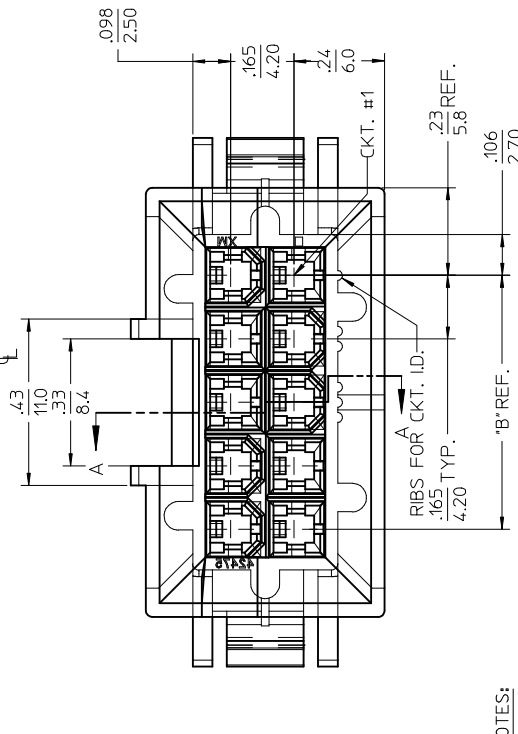

.530 MAX  
13.46  
SEE NOTE 10

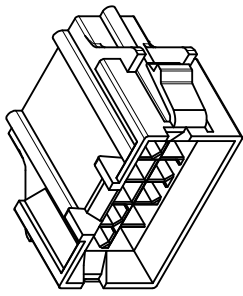
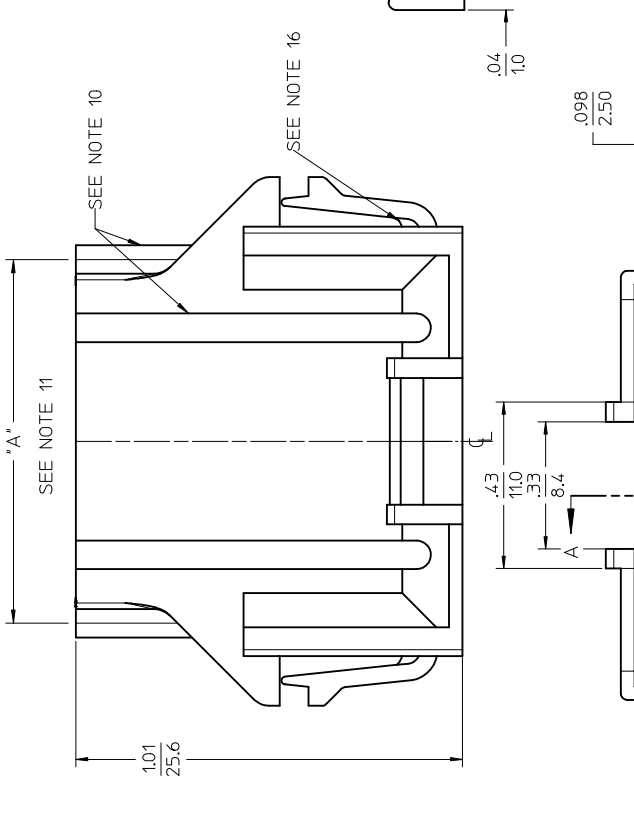

SECTION "A-A"  
TERMINAL ORIENTATION

SEE NOTE #13

RECOMMENDED CUT  
.038/(0.97) MIN.

- NOTES:
- MATERIAL:
    - NYLON (PA6/6), UNFILLED, UL94 V-2, COLOR: NATURAL
    - NYLON (PA6/6), UNFILLED, UL94 V-0, COLOR: NATURAL (WHITE)
    - NYLON (PA6/6), UNFILLED, UL94 V-2, COLOR: BLACK
    - NYLON (PA6/6), UNFILLED, UL94 V-0, COLOR: BLACK
 FINISH NOT APPLICABLE.
  - PRODUCT SPECIFICATION: PS-5556-002
  - PACKAGING SPECIFICATION: PK-42474-001
  - 6-24 CKT. PARTS MATE WITH MOLEX RECEPTACLES 5557, 42385 AND 42474. 2 AND 4 CKT. PARTS MATE WITH 42385 AND 42474 ONLY.
  - PART IS FOR USE WITH MALE TERMINAL #5558.
  - PART ALLOWS FOR UP TO .100/(2.54) MISALIGNMENT WITH MATING RECEPTACLE IN ANY DIRECTION. SEE MATING CONNECTOR DRAWINGS FOR SPECIFIC ALLOWANCES.
  - PANEL CUT-OUT TO BE PUNCHED IN THE SAME DIRECTION AS CONNECTOR INSERTION.
  - PART CONFORMS TO CLASS 'B' REQUIREMENTS OF COSMETIC SPECIFICATION PS-45499-022.

- FOR MANUFACTURING EASE PARTS MAY HAVE OPTIONAL EJECTOR RIBS. SEE SHIT. 3 FOR LOCATION.
- DIMENSION DOES NOT INCLUDE EJECTOR RIBS (SEE PAGE #3 FOR PARTS WITH RIBS, RIB DIMENSIONS AND LOCATION).
- IF THIS PRODUCT IS STORED IN AN ENVIRONMENT WITH A RELATIVE HUMIDITY OF LESS THAN 50%, MOISTURE MUST BE ADDED. REFER TO TECHNICAL ADVISORY AS-45499-001 FOR INSTRUCTIONS.
- INTERIOR RIB LOCATION MAY VARY.

- CONNECTOR A OR UNMATED
- WIRES ARE TO TERMINALS TO PARTS MAY VARY

QUALITY SYMBOLS	GENERAL TOLERANCES (UNLESS SPECIFIED)	DIMENSION STYLE
∇=0	4 PLACES ± --- ± ---	IN/MM
∇=0	3 PLACES ± --- ± 0.10	DRAWN BY
∇=0	2 PLACES ± 0.25 ± 0.15	DATE
∇=0	1 PLACE ± 0.38 ± ---	CHECKED BY
	ANGULAR ±1/2°	RJF
		APPROVED BY
		DATE
		FSMITH
		2011/09/02
		MATERIAL NO.

DRAFT WHERE APPLICABLE MUST REMAIN WITHIN DIMENSIONS

SEE SHEET 4  
THIS DRAWING CONTAINS INCORPORATED AND SH

SEE SHEET 2 FOR 2 & 4 CKT. PARTS

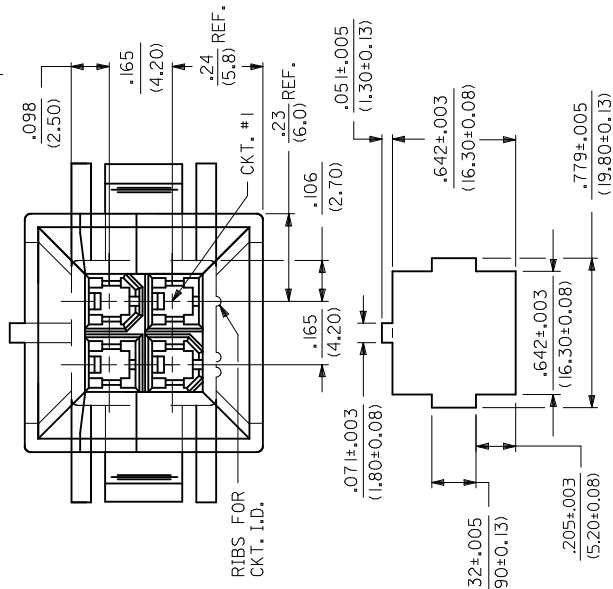
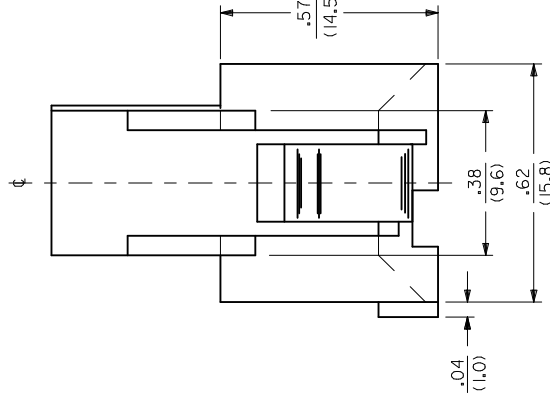
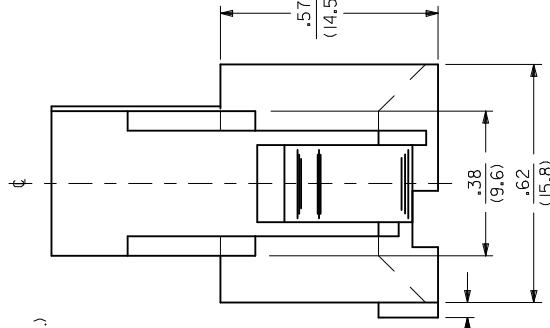
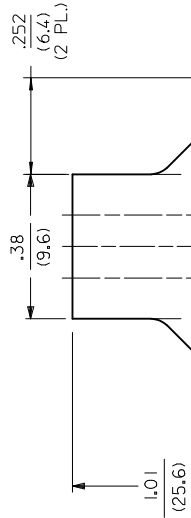

RECOMMENDED CUT-OUT FOR .063/(1.60)  
MAX. THICK PANEL (4 CKT'S.)

SCALE: 2X

4 CKT.

CKT.

.24  
(6.0)

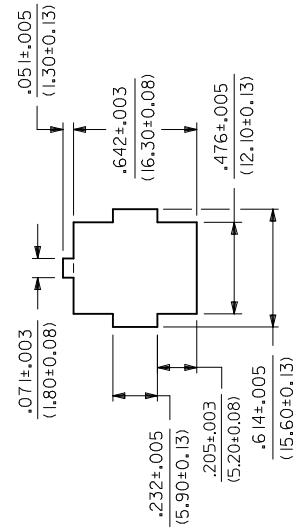

RECOMMENDED CUT-OUT FOR .063/(1.60)  
MAX. THICK PANEL #1 (2 CKT'S.)

SCALE: 2X

2 CKT.

REV	DESCRIPTION
S14	EC NO: UCP2015-4971 DRWN:CSLAFTER CHKD:JBELL APP:FSMITH 2016/04/05

QUALITY SYMBOLS	GENERAL TOLERANCES (UNLESS SPECIFIED)	INCH	M/M
	± .010	± .010	± .254
	± .015	± .015	± .381
	± .038	± .038	± .965
	ANGULAR ±1/2°		

DRAFT WHERE APPLICABLE  
MUST REMAIN WITHIN DIMENSIONS

SEE SHEET 4  
SIZE THIS DRAWING CONTAINED AND INCORPORATED AND S

DIMENSION STYLE	DATE	DATE
IN/M/M	1989/07/18	1989/07/18
DRAWN BY	GEP	1989/07/18
CHECKED BY	RJF	1989/07/18
APPROVED BY	FSMITH	2011/09/02
MATERIAL NO		



13	12	11	10	9	8	7	6	5	4
PART NUMBER	ENC. NUMBER	CKT. SIZE	MATERIAL (SEE NOTE 1.)	PART NUMBER	CKT. SIZE	MATERIAL (SEE NOTE 1.)			
J	NOT TOOLED	42475-0211	2	1					
	I5-06-0045	42475-0411	4						
	I5-06-0065	42475-0611	6						
	I5-06-0085	42475-0811	8						
I	I5-06-0105	42475-1011	10						
	NOT TOOLED	42475-1211	12						
	I5-06-0145	42475-1411	14						
	NOT TOOLED	42475-1611	16						
H	I5-06-0185	42475-1811	18						
	O I5-06-0205	42475-2011	20						
	NOT TOOLED	42475-2211	22						
	I5-06-0245	42475-2411	24	1					
G									
	NOT TOOLED	42475-0221	2	2					
	I5-06-0046	42475-0421	4						
	I5-06-0066	42475-0621	6						
F	50-36-2323	42475-0821	8						
	I5-06-0106	42475-1021	10						
	NOT TOOLED	42475-1221	12						
	I5-06-0146	42475-1421	14						
E	NOT TOOLED	42475-1621	16						
	I5-06-0186	42475-1821	18						
	O I5-06-0206	42475-2021	20						
	NOT TOOLED	42475-2221	22						
D	I5-06-0246	42475-2421	24	2					
O = OBSOLETE									
LEGEND:									
C									
B									
A									

O = OBSOLETE

LEGEND:

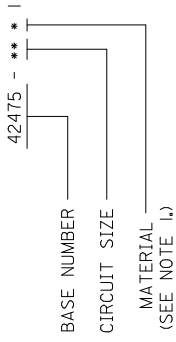

QUALITY SYMBOLS	GENERAL TOLERANCES (UNLESS SPECIFIED)	DIMENSION STYLE
▽=0	mm ±----	IN/MM
▽=0	4 PLACES ±----	DRAWN BY
▽=0	3 PLACES ±----	GEP
	2 PLACES ±---	CHECKED BY
	1 PLACE ±0.38 ±---	RJF
	ANGULAR ±1/2°	APPROVED BY
	DRAFT WHERE APPLICABLE MUST REMAIN WITHIN DIMENSIONS	FSMITH
		MATERIAL NO.
		2011709102
SEE CHART		
SIZE THIS DRAWING CONTAINED INCORPORATED AND S		

DESCRIPTION	REV
DRM:CSLAFTER	S14
EC NO: UCP2015-4971	
CHKD:JBELL	
APP:FSMITH	
2016/04/05	
2016/04/05	

## Looking for pricing, stock, or lifecycle information?

Click below to explore more details on WIN SOURCE:

 [View 15-06-0146 on WIN SOURCE](#)

 [Molex, LLC Information](#)

## Optimize Your Supply Chain with WIN SOURCE Solutions

-  Global Sourcing Solution
-  Obsolete Management
-  Cost Control Management
-  Shortage Management
-  Alternative Solution
-  Excess Inventory Management