

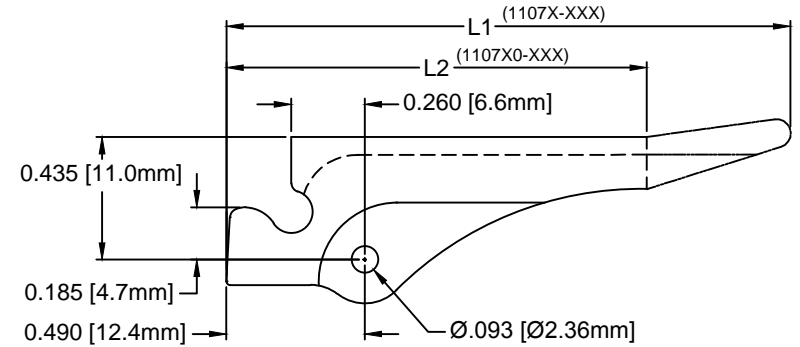

**THE DATASHEET OF
1107310-125 NT**

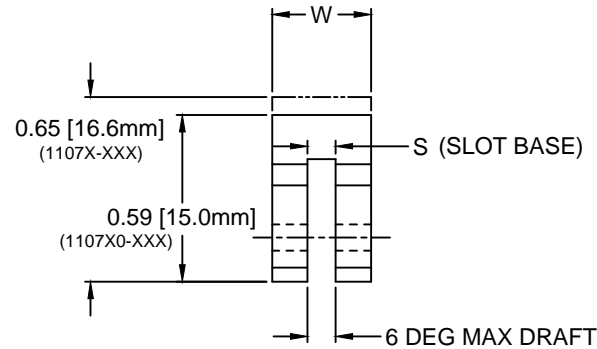

REVISIONS			
REV.	DESCRIPTION	DATE	APPROVED
C	Engineering Update w/o Changes	02/13/04	M. C.
D	Updated S Dimension	11/26/07	M. C.
E	Updated 14-NL Material to 94V-0	09/11/12	T. Y.
F	Added Notes 3, 4, 5 & Color Options Sheet #2	05/16/16	J. C.
G	Updated Color Options Sheet #2	07/06/18	M. C.
H	Changed Material to Halogen Free, ECO 1026	10/17/19	A. V.



PART NO.	COLOR	S	W	L1	L2	PCB THICKNESS	ROLL PIN	DESC
1107-062 XX	SEE S.#2	.075 (1.9mm)	.290 (7.4mm)	2.0 (50.8mm)	-	.062 (1.6mm)	RP-250	83023-09
11073-062 NT	NATURAL	.075 (1.9mm)	.350 (8.9mm)	2.0 (50.8mm)	-	.062 (1.6mm)	RP-312	-
11073-093 XX	SEE S.#2	.100 (2.5mm)	.350 (8.9mm)	2.0 (50.8mm)	-	.093 (2.4mm)	RP-312	-
11073-125 NT	NATURAL	.140 (3.6mm)	.350 (8.9mm)	2.0 (50.8mm)	-	.125 (3.2mm)	RP-312	83023-10
110710-062 XX	SEE S.#2	.075 (1.9mm)	.290 (7.4mm)	-	1.5 (38.1mm)	.062 (1.6mm)	RP-250	83023-11
1107310-062 NT	NATURAL	.075 (1.9mm)	.350 (8.9mm)	-	1.5 (38.1mm)	.062 (1.6mm)	RP-312	-
1107310-093 XX	SEE S.#2	.100 (2.5mm)	.350 (8.9mm)	-	1.5 (38.1mm)	.093 (2.4mm)	RP-312	-
1107310-125 NT	NATURAL	.140 (3.6mm)	.350 (8.9mm)	-	1.5 (38.1mm)	.125 (3.2mm)	RP-312	-

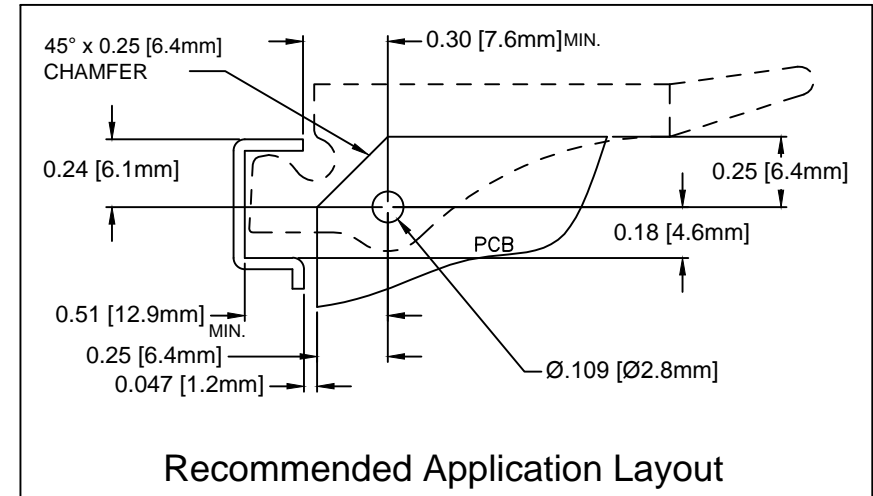

STANDARD TOLERANCE (UNLESS OTHERWISE SPECIFIED)		 BIVAR [®] 4 THOMAS, IRVINE, CA. 92618 TEL: (949) 951-8808 FAX: (949) 951-3974	
DECIMALS	ANGULAR		
.X ±.1 .XX ±.01 .XXX ±.005	X° ± 1°		
DESIGNED: D. GREEN	DATE: 04/16/03	TITLE: PCB INSERTER/EXTRACTOR	
REVISOR: TD. NGUYEN	DATE: 10/17/19	DRAWING NO: 1107XXX-XXX XX	REVISION: H
CHECKED: K. BARON	DATE: 11/18/19	SHEET SIZE A	CAGE CODE: 32559
		SCALE: NONE	SHEET # 1 OF 2
CAD GENERATED DOCUMENT, DO NOT MEASURE DRAWING			

4. PRE-ASSEMBLED ROLL PINS AVAILABLE UPON REQUEST.
3. ROLL PINS INCLUDED. PACKAGED SEPARATELY.
2. MATERIAL: NYLON 6/6, 30% GLASS FILLED, HALOGEN FREE, 94V-0 NATURAL COLOR.
1. GENERAL SPECIFICATIONS: BIVAR MOLDED COMPONENT SPECIFICATION BV00-E101.

OTHER AVAILABLE COLORS
 * SEE TABLE FOR ORDERING INFORMATION

REVISIONS			
REV.	DESCRIPTION	DATE	APPROVED
-	See Sheet 1		

1 1 0 7 - - - - -

SERIES
1107-062
11073-093
110710-062
1107310-093

ORDER CODE	COLOR	PANTONE CODE
BK	BLACK	
BE	BLUE	PQ-BLUE072C
GN	GREEN	PQ-2258C
NT	NATURAL	
RD	RED	PQ-19-1664TCX
WE	WHITE	
YW	YELLOW	PQ-YELLOWC



PART NO: 1107XXX-XXX XX		REVISION: H
SCALE: NONE	SHEET # 2 OF 2	
CAD GENERATED DOCUMENT, DO NOT MEASURE DRAWING		

Looking for pricing, stock, or lifecycle information?

Click below to explore more details on WIN SOURCE:

 [View 1107310-125 NT on WIN SOURCE](#)

 [Bivar Inc. Information](#)

Optimize Your Supply Chain with WIN SOURCE Solutions

-  Global Sourcing Solution
-  Obsolete Management
-  Cost Control Management
-  Shortage Management
-  Alternative Solution
-  Excess Inventory Management