

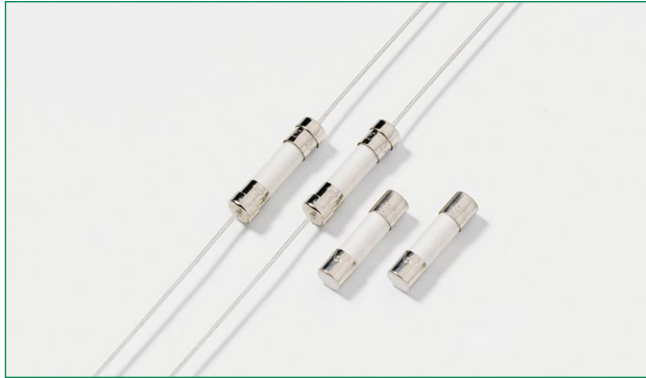

THE DATASHEET OF
021612.5MXP



216 Series, 5x20 mm, Fast-Acting Fuse



Description

5x20mm fast-acting ceramic body cartridge fuse designed to IEC specification.

Features

- Designed to International (IEC) Standards for use globally
- Meets the IEC 60127-2, sheet 1 specification for fast-acting fuses
- Available in cartridge and axial lead form
- RoHS compliant and lead-free

Agency Approvals

Agency	Agency File Number	Ampere Range
	Cartridge: 1-5A NBK 080205-E10480A 6.3A-10A NBK 250702-E10480E 12.5A NBK 240108-JP1021C 16A NBK 240108-JP1021E	1A – 16A
	Leaded: 1-5A NBK 080205-E10480B 6.3A-10A NBK 250702-E10480F 12.5A NBK 240108-JP1021D 16A NBK 240108-JP1021F	
	2003010207079960	0.05A – 6.3A
	SU05001-2013	1A – 10A
	E10480	0.05A – 16A
	29862	
	1402843	0.05A - 10A, 16A
	40013834	0.05A – 6.3A *8A, *10A
	40016442	*12.5A
	KM41462	1A – 6.3A
	J50248090	8A – 16A
	N/A	0.05A – 16A

*Approval for Cartridge versions only

Applications

Used as supplementary protection in appliance or utilization equipment to provide individual protection for components or internal circuits.

Electrical Characteristics for Series

% of Ampere Rating	Ampere Rating	Opening Time
150%	0.05A – 4A	60 minutes, Minimum
	5A – 6.3A	60 minutes, Minimum
	8A – 16A	30 minutes, Minimum
210%	0.05A – 4A	30 minutes, Maximum
	5A – 6.3A	30 minutes, Maximum
	8A – 16A	30 minutes, Maximum
275%	0.05A – 4A	0.01 sec., Min.; 2 sec. Max.
	5A – 6.3A	0.01 sec., Min.; 3 sec. Max.
	8A – 16A	0.04 sec., Min.; 20 sec. Max.
400%	0.05A – 4A	.003 sec., Min.; 0.3 sec. Max.
	5A – 6.3A	.003 sec., Min.; 0.3 sec. Max.
	8A – 16A	.01 sec., Min.; 1.0 sec. Max.
1000%	0.05A – 4A	.02 seconds, Maximum
	5A – 6.3A	.02 seconds, Maximum
	8A – 16A	.03 sec.onds, Maximum

Additional Information



Datasheet



Resources



Samples



Accessories

For recommended fuse accessories for this product series, see '[Recommended Accessories](#)' section.

Electrical Characteristics Specifications by Item

Amp Code	Amp Rating (A)	Voltage Rating (V)	Interrupting Rating	Nominal Cold Resistance (Ohms)	Nominal Melting I ² t (A ² sec)	Maximum Voltage Drop at Rated Current (mV)	Maximum Power Dissipation at 1.5I _n (W)	Agency Approvals												
								UL	CCC	CSA	UL US	SP	S	CE	D E	VDE	UL	PS E		
.050	0.05	250	1500A@250Vac	15.9000	0.00019	10000	1.6				X	X	X	X	X	X				
.063	0.063	250		10.4500	0.00079	8800	1.6				X	X	X	X	X	X				
.080	0.08	250		7.8850	0.00084	7600	1.6				X	X	X	X	X	X				
.100	0.1	250		5.7925	0.00450	7000	1.6				X	X	X	X	X	X				
.125	0.125	250		3.6750	0.00546	5000	1.6				X	X	X	X	X	X				
.160	0.16	250		5.3490	0.00326	4300	1.6				X	X	X	X	X	X				
.200	0.2	250		3.3500	0.00439	3500	1.6				X	X	X	X	X	X				
.250	0.25	250		2.3500	0.01350	2800	2.5				X	X	X	X	X	X				
.315	0.315	250		1.8500	0.02320	2500	2.5				X	X	X	X	X	X				
.500	0.5	250		0.8660	0.16500	1800	2.5				X	X	X	X	X	X				
.630	0.63	250		0.4650	0.05940	1500	2.5				X	X	X	X	X	X				
.800	0.8	250		0.2950	0.14600	1200	2.5				X	X	X	X	X	X				
001.	1	250		0.2370	0.18000	1000	2.5			X	X	X	X	X	X	X				X
1.25	1.25	250		0.1530	0.48000	800	4			X	X	X	X	X	X	X				X
01.6	1.6	250		0.1112	1.00500	600	4			X	X	X	X	X	X	X				X
002.	2	250		0.0764	1.87000	500	4			X	X	X	X	X	X	X				X
02.5	2.5	250		0.0584	3.67200	400	4			X	X	X	X	X	X	X				X
3.15	3.15	250		0.0368	6.70000	350	4			X	X	X	X	X	X	X				X
004.	4	250		0.0247	14.99500	300	4			X	X	X	X	X	X	X				X
005.	5	250		0.0183	27.46000	250	4			X	X	X	X	X	X	X				X
06.3	6.3	250	0.0137	56.43000	200	4			X	X	X	X	X	X	X				X	
008.	8	250	0.0123	64.31500	200	4				X	X	X	X	X	X*			X	X	
010.	10	250	0.0079	154.34000	200	4			X		X	X	X	X	X*			X	X	
12.5	12.5	250	0.0057	175.00000	200	N/A**					X	X		X		X*		X	X	
016.	16	250	750A@250Vac	0.0040	462.50000	200	N/A**				X***	X	X	X			X***		X	

* Approval for cartridge versions only.
 N/A** - Please contact Littelfuse for details on these parameters
 I²t test at 10x rated current
 ***1500A@250Vac for 16A

Temperature Re-rating Curve

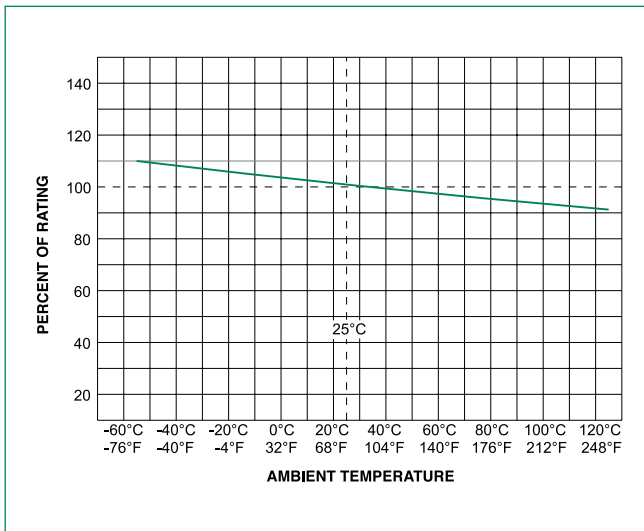

Note: Re-rating depicted in this curve is in addition to the standard derating of 25% for continuous operation.

Average Time Current Curves

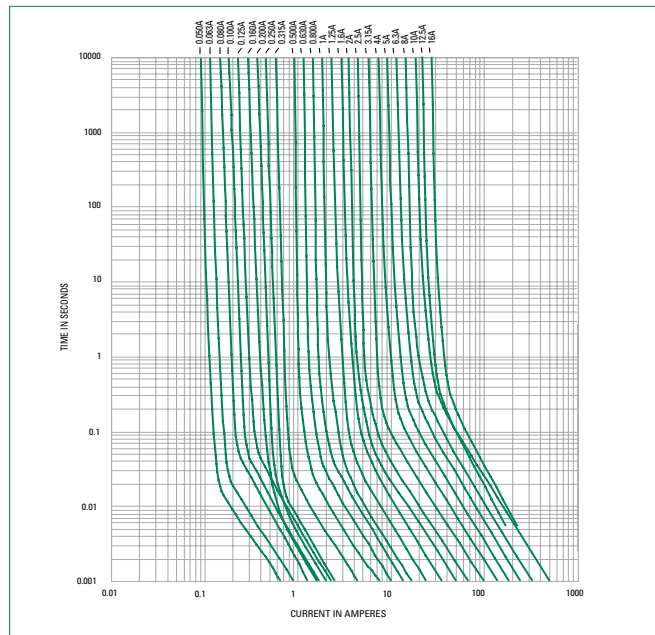

Soldering Parameters - Wave Soldering

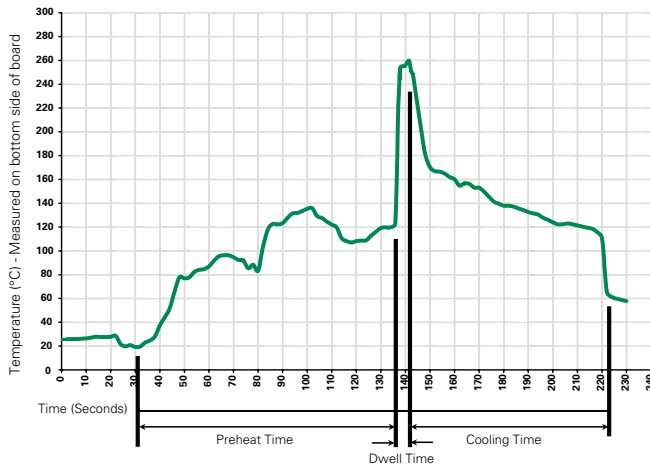

Recommended Process Parameters:

Wave Parameter	Lead-Free Recommendation
Preheat: (Depends on Flux Activation Temperature)	(Typical Industry Recommendation)
Temperature Minimum:	100°C
Temperature Maximum:	150°C
Preheat Time:	60-180 seconds
Solder Pot Temperature:	260°C Maximum
Solder Dwell Time:	2-5 seconds

Recommended Hand-Solder Parameters:

Solder Iron Temperature: 350°C +/- 5°C
Heating Time: 5 seconds max.

Note: These devices are not recommended for IR or Convection Reflow process.

Product Characteristics

Material	Body: Ceramic Cap: Nickel-plated brass Leads: Tin-plated Copper Filler (160mA-16A): Sand
Terminal Strength	MIL-STD-202, Method 211, Test Condition A
Solderability	MIL-STD-202 Method 208
Product Marking	Cap 1: Brand logo, current and voLage rating Cap 2: Agency approval markings
Packaging	Available in Bulk (M=1000 pcs/pkg) or on Tape/Reel (MRET1=1000 pcs/reel)

Operating Temperature	-55°C to +125°C
Thermal Shock	MIL-STD-202, Method 107, Test Condition B: (5 cycles -65°C to +125°C)
Vibration	MIL-STD-202, Method 201
Humidity	MIL-STD-202, Method 103, Test Condition A. high RH (95%) and elevated temperature (40°C) for 240 hours.
Salt Spray	MIL-STD-202, Method 101, Test Condition B

Dimensions

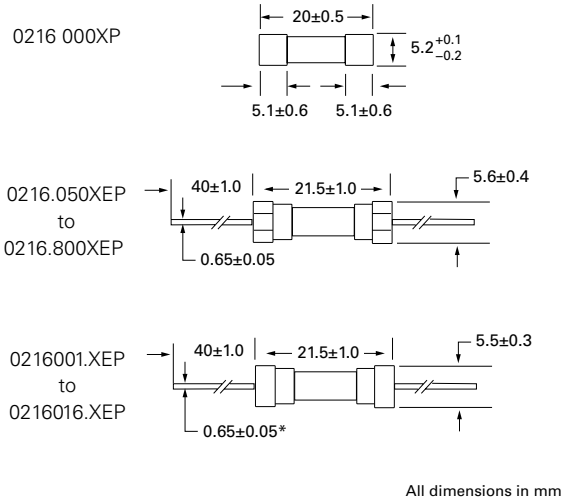

Notes:
* Ratings above 6.3 A have 0.8 ± 0.05 diameter lead.

Part Numbering System

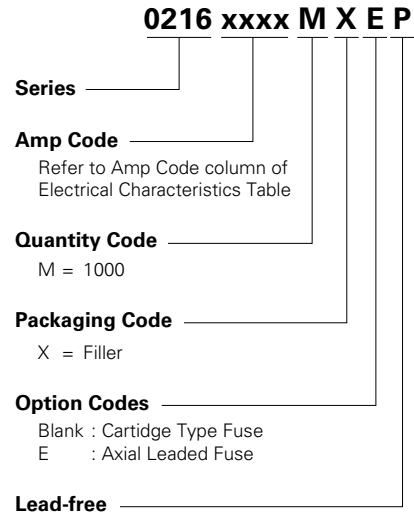

Packaging

Packaging Option	Packaging Specification	Quantity	Quantity & Packaging Code	Taping Width
216 Series				
Bulk	N/A	1000	MX	N/A
Bulk	N/A	1000	MXE	N/A
Reel and Tape	EIA 296-E	1000	MRET1	T1=53mm (2.087")
Bulk	N/A	1000	MXG	N/A
Bulk	N/A	1000	MXB	N/A
Bulk	N/A	100	HX	N/A

Recommended Accessories

Accessory Type	Series	Description	Max Application Voltage	Max Application Amperage
Holder	345_ISF	Panel Mount Shock-Safe Fuseholder	250	10
	345	Shock-Safe Fuseholder with PC Mount, Solder Mount and Panel Mount options		20A
	830	PC Mount Shock-Safe Miniature Fuseholder		16
Block	520	Metric OMNI-BLOK® Fuse Block		10
	646	PC Mount Miniature Fuse Block		6.3
	658	Surface Mount Miniature Fuse Block		10
Clip	520_W	PC Mount Miniature Fuse Clip		6.3
	111	PC Board Mount Fuse Clip		10
	445	PC Board Mount Fuse Clip		10

Notes:
1. Do not use in applications above rating.
2. Please refer to fuseholder data sheet for specific re-rating information.
3. Please contact Littelfuse for applications greater than the max voltage and amperage shown.

Disclaimer Notice - Information furnished is believed to be accurate and reliable. However, users should independently evaluate the suitability of and test each product selected for their own applications. Littelfuse products are not designed for, and may not be used in, all applications. Read complete Disclaimer Notice at: www.littelfuse.com/disclaimer-electronics.

Looking for pricing, stock, or lifecycle information?

Click below to explore more details on WIN SOURCE:

 [View 021612.5MXP on WIN SOURCE](#)

 [Littelfuse Inc. Information](#)

Optimize Your Supply Chain with WIN SOURCE Solutions

-  Global Sourcing Solution
-  Obsolete Management
-  Cost Control Management
-  Shortage Management
-  Alternative Solution
-  Excess Inventory Management