



**THE DATASHEET OF
S25FL032P0XMFI003**



This product family has been retired and is not recommended for designs. For new and current designs, S25FL064L supersedes S25FL032P. These are the factory-recommended migration paths. Refer to the S25FL-L Family datasheets for specifications and ordering information.

Distinctive Characteristics

Architectural Advantages

- Single power supply operation
 - Full voltage range: 2.7 V to 3.6 V read and write operations
- Memory architecture
 - Uniform 64-KB sectors
 - Top or bottom parameter block (two 64-KB sectors (top or bottom) broken down into 16 4-KB sub-sectors each)
 - 256-byte page size
 - Backward compatible with the S25FL032A device
- Program
 - Page Program (up to 256 bytes) in 1.5 ms (typical)
 - Program operations are on a page by page basis
 - Accelerated programming mode via 9-V W#/ACC pin
 - Quad Page Programming
- Erase
 - Bulk erase function
 - Sector erase (SE) command (D8h) for 64-KB sectors
 - Sub-sector erase (P4E) command (20h) for 4-KB sectors
 - Sub-sector erase (P8E) command (40h) for 8-KB sectors
- Cycling endurance
 - 100,000 cycles per sector typical
- Data retention
 - 20 years typical
- Device ID
 - JEDEC standard two-byte electronic signature
 - RES command one-byte electronic signature for backward compatibility
- One time programmable (OTP) area for permanent, secure identification; can be programmed and locked at the factory or by the customer

- Common Flash Interface (CFI) compliant: allows host system to identify and accommodate multiple flash devices
- Process technology
 - Manufactured on 0.09 μm MirrorBit® process technology
- Package option
 - Industry Standard Pinouts
 - 8-pin SO package (208 mils)
 - 16-pin SO package (300 mils)
 - 8-contact USON package (5 × 6 mm)
 - 8-contact WSON package (6 × 8 mm)
 - 24-ball BGA 6 × 8 mm package, 5 × 5 pin configuration
 - 24-ball BGA 6 × 8 mm package, 6 × 4 pin configuration

Performance Characteristics

- Speed
 - Normal READ (Serial): 40-MHz clock rate
 - FAST_READ (Serial): 104-MHz clock rate (maximum)
 - DUAL I/O FAST_READ: 80-MHz clock rate or 20 MB/s effective data rate
 - QUAD I/O FAST_READ: 80 MHz clock rate or 40 MB/s effective data rate
- Power saving standby mode
 - Standby Mode 80 μA (typical)
 - Deep Power-Down Mode 3 μA (typical)

Memory Protection Features

- Memory protection
 - W#/ACC pin works in conjunction with Status Register Bits to protect specified memory areas
 - Status Register Block Protection bits (BP2, BP1, BP0) in status register configure parts of memory as read-only

General Description

The S25FL032P is a 3.0 V (2.7 V to 3.6 V), single-power-supply Flash memory device. The device consists of 64 uniform 64-KB sectors with the two (top or bottom) 64-KB sectors further split up into thirty-two 4-KB sub sectors. The S25FL032P device is fully backward compatible with the S25FL032A device.

The device accepts data written to Serial Input (SI) and outputs data on Serial Output (SO). The devices are designed to be programmed in-system with the standard system 3.0-V V_{CC} supply.

The S25FL032P device adds the following high-performance features using five new instructions:

- Dual Output Read using both SI and SO pins as output pins at a clock rate of up to 80 MHz
- Quad Output Read using SI, SO, W#/ACC, and HOLD# pins as output pins at a clock rate of up to 80 MHz
- Dual I/O High Performance Read using both SI and SO pins as input and output pins at a clock rate of up to 80 MHz
- Quad I/O High Performance Read using SI, SO, W#/ACC, and HOLD# pins as input and output pins at a clock rate of up to 80 MHz
- Quad Page Programming using SI, SO, W#/ACC, and HOLD# pins as input pins to program data at a clock rate of up to 80 MHz

The memory can be programmed 1 to 256 bytes at a time, using the Page Program command. The device supports Sector Erase and Bulk Erase commands.

Each device requires only a 3.0-V power supply (2.7 V to 3.6 V) for both read and write functions. Internally generated and regulated voltages are provided for the program operations. This device requires a high voltage supply to the W#/ACC pin to enable the Accelerated Programming mode.

The S25FL032P device also offers a One-Time Programmable area (OTP) of up to 128 bits (16 bytes) for permanent secure identification and an additional 490 bytes of OTP space for other use. This OTP area can be programmed or read using the OTPR or OTPR instructions.

Not Recommended for New Design

Contents

| | | | |
|---|----|--|-----------|
| 1. Block Diagram | 4 | 9.19 Deep Power-Down (DP) | 38 |
| 2. Connection Diagrams | 5 | 9.20 Release from Deep Power-Down (RES)..... | 39 |
| 3. Input/Output Descriptions | 7 | 9.21 Clear Status Register (CLSR)..... | 40 |
| 4. Logic Symbol | 7 | 9.22 OTP Program (OTPP)..... | 40 |
| 5. Ordering Information | 8 | 9.23 Read OTP Data Bytes (OTPR)..... | 40 |
| 5.1 Valid Combinations | 9 | 10. OTP Regions | 41 |
| 6. SPI Modes | 10 | 10.1 Programming OTP Address Space..... | 41 |
| 7. Device Operations | 11 | 10.2 Reading OTP Data | 41 |
| 7.1 Byte or Page Programming..... | 11 | 10.3 Locking OTP Regions..... | 42 |
| 7.2 Quad Page Programming | 11 | 11. Power-up and Power-down | 44 |
| 7.3 Dual and Quad I/O Mode..... | 11 | 12. Initial Delivery State | 45 |
| 7.4 Sector Erase / Bulk Erase..... | 11 | 13. Program Acceleration via W#/ACC Pin | 45 |
| 7.5 Monitoring Write Operations | | 14. Electrical Specifications | 46 |
| Using the Status Register | 11 | 14.1 Absolute Maximum Ratings | 46 |
| 7.6 Active Power and Standby Power Modes..... | 11 | 15. Operating Ranges | 47 |
| 7.7 Status Register | 12 | 16. DC Characteristics | 47 |
| 7.8 Configuration Register | 12 | 17. Test Conditions | 48 |
| 7.9 Data Protection Modes | 13 | 18. AC Characteristics | 49 |
| 7.10 Hold Mode (HOLD#) | 14 | 18.1 Capacitance..... | 50 |
| 7.11 Accelerated Programming Operation..... | 15 | 19. Physical Dimensions | 52 |
| 8. Sector Address Table | 16 | 19.1 SOC008 wide — 8-pin Plastic Small | |
| 9. Command Definitions | 18 | Outline Package (208-mils Body Width) | 52 |
| 9.1 Read Data Bytes (READ) | 20 | 19.2 SO3 016 — 16-pin Wide Plastic Small | |
| 9.2 Read Data Bytes at Higher Speed | | Outline Package (300-mils Body Width) | 53 |
| (FAST_READ) | 20 | 19.3 UNE008 — USON 8-contact (5 x 6 mm) | |
| 9.3 Dual Output Read Mode (DOR)..... | 21 | No-Lead Package | 54 |
| 9.4 Quad Output Read Mode (QOR) | 21 | 19.4 WNF008 — WSON 8-contact (6 x 8 mm) | |
| 9.5 DUAL I/O High Performance Read | | No-Lead Package | 55 |
| Mode (DIOR)..... | 22 | 19.5 FAB024 — 24-ball Ball Grid Array | |
| 9.6 Quad I/O High Performance Read | | (6 x 8 mm) Package..... | 56 |
| Mode (QIOR) | 23 | 19.6 FAC024 — 24-ball Ball Grid Array | |
| 9.7 Read Identification (RDID)..... | 25 | (6 x 8 mm) Package..... | 57 |
| 9.8 Read-ID (READ_ID)..... | 28 | 20. Revision History | 58 |
| 9.9 Write Enable (WREN)..... | 29 | Document History Page | 58 |
| 9.10 Write Disable (WRDI)..... | 29 | Sales, Solutions, and Legal Information | 60 |
| 9.11 Read Status Register (RDSR) | 30 | Worldwide Sales and Design Support | 60 |
| 9.12 Read Configuration Register (RCR) | 31 | Products | 60 |
| 9.13 Write Registers (WRR) | 32 | PSoC® Solutions | 60 |
| 9.14 Page Program (PP)..... | 33 | Cypress Developer Community | 60 |
| 9.15 QUAD Page Program (QPP) | 35 | Technical Support | 60 |
| 9.16 Parameter Sector Erase (P4E, P8E) | 36 | | |
| 9.17 Sector Erase (SE)..... | 37 | | |
| 9.18 Bulk Erase (BE) | 37 | | |

1. Block Diagram

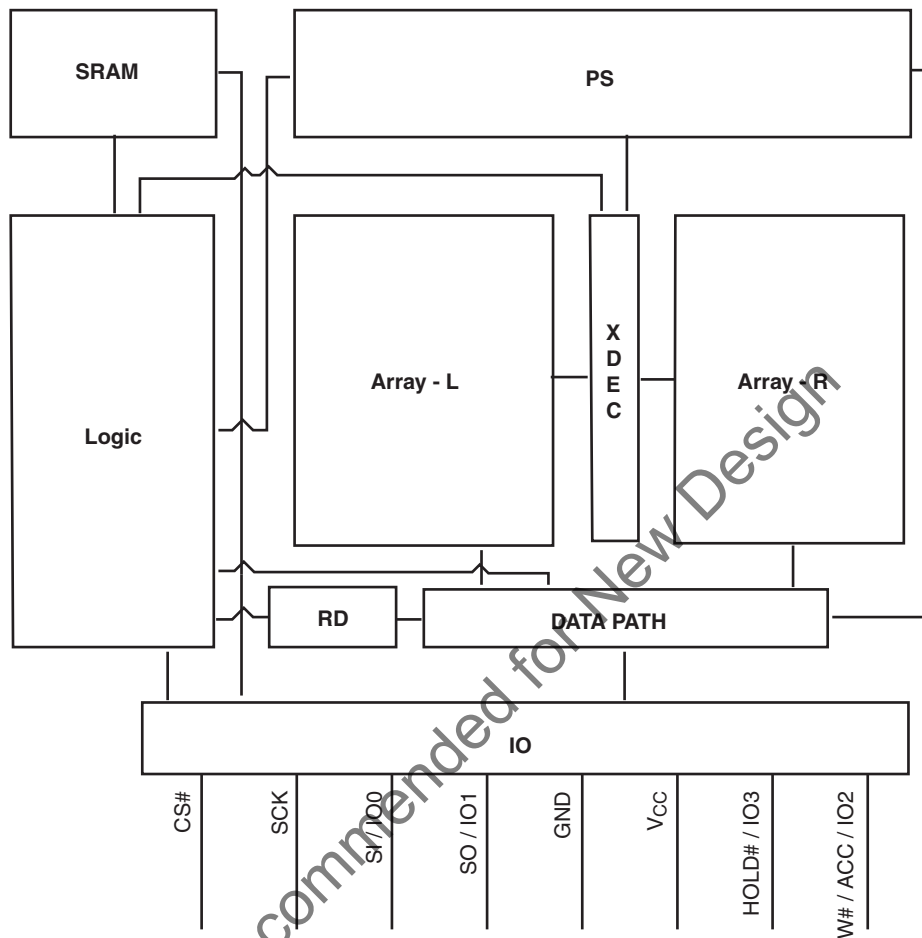

2. Connection Diagrams

Figure 1. 16-pin Plastic Small Outline Package (SO)

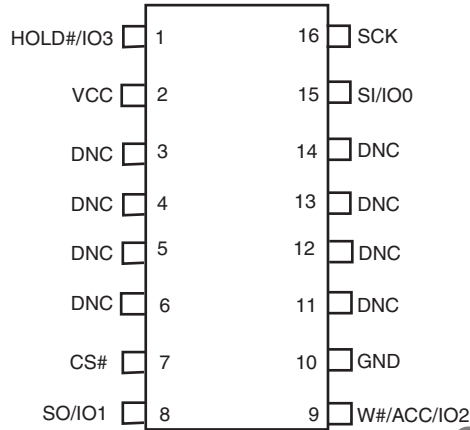

Note

DNC = Do Not Connect (Reserved for future use)

Figure 2. 8-pin Plastic Small Outline Package (SO)

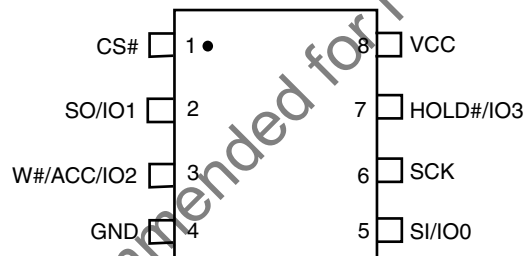
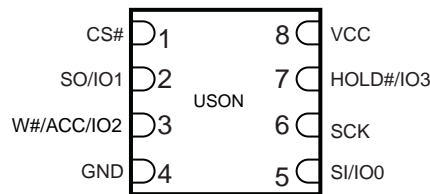

Figure 3. 8-contact USON (5 x 6 mm) Package



Note

There is an exposed central pad on the underside of the USON package. This should not be connected to any voltage or signal line on the PCB. Connecting the central pad to GND (V_{SS}) is possible, provided PCB routing ensures 0mV difference between voltage at the USON GND (V_{SS}) lead and the central exposed pad.

Figure 4. 8-contact WSON Package (6 x 8 mm)

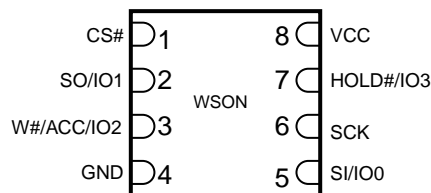

Note

There is an exposed central pad on the underside of the WSON package. This should not be connected to any voltage or signal line on the PCB. Connecting the central pad to GND (V_{SS}) is possible, provided PCB routing ensures 0mV difference between voltage at the WSON GND (V_{SS}) lead and the central exposed pad.

Figure 5. 6x8 mm 24-ball BGA Package, 5x5 Pin Configuration

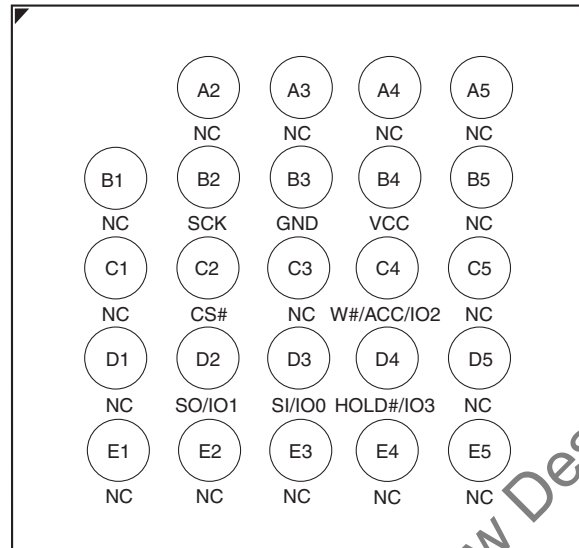
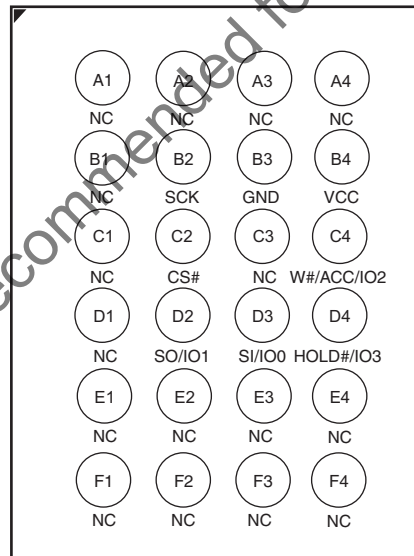

Figure 6. 6x8 mm 24-ball BGA Package, 6x4 Pin Configuration



Not Recommended for New Design

3. Input/Output Descriptions

Table 1. Input/Output Descriptions

| Signal | I/O | Description |
|-----------------|-------|--|
| SO/IO1 | I/O | Serial Data Output: Transfers data serially out of the device on the falling edge of SCK. Functions as an input pin in Dual and Quad I/O, and Quad Page Program modes. |
| SI/IO0 | I/O | Serial Data Input: Transfers data serially into the device. Device latches commands, addresses, and program data on SI on the rising edge of SCK. Functions as an output pin in Dual and Quad I/O mode. |
| SCK | Input | Serial Clock: Provides serial interface timing. Latches commands, addresses, and data on SI on rising edge of SCK. Triggers output on SO after the falling edge of SCK. |
| CS# | Input | Chip Select: Places device in active power mode when driven low. Deselects device and places SO at high impedance when high. After power-up, device requires a falling edge on CS# before any command is written. Device is in standby mode when a program, erase, or Write Status Register operation is not in progress. |
| HOLD#/IO3 | I/O | Hold: Pauses any serial communication with the device without deselecting it. When driven low, SO is at high impedance, and all input at SI and SCK are ignored. Requires that CS# also be driven low. Functions as an output pin in Quad I/O mode. |
| W#/ACC/IO2 | I/O | Write Protect: Protects the memory area specified by Status Register bits BP2:BP0. When driven low, prevents any program or erase command from altering the data in the protected memory area. Functions as an output pin in Quad I/O mode. |
| V _{CC} | Input | Supply voltage |
| GND | Input | Ground |

4. Logic Symbol

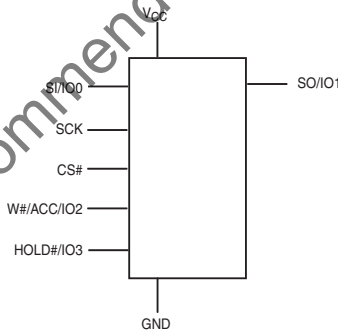

5. Ordering Information

The ordering part number is formed by a valid combination of the following:

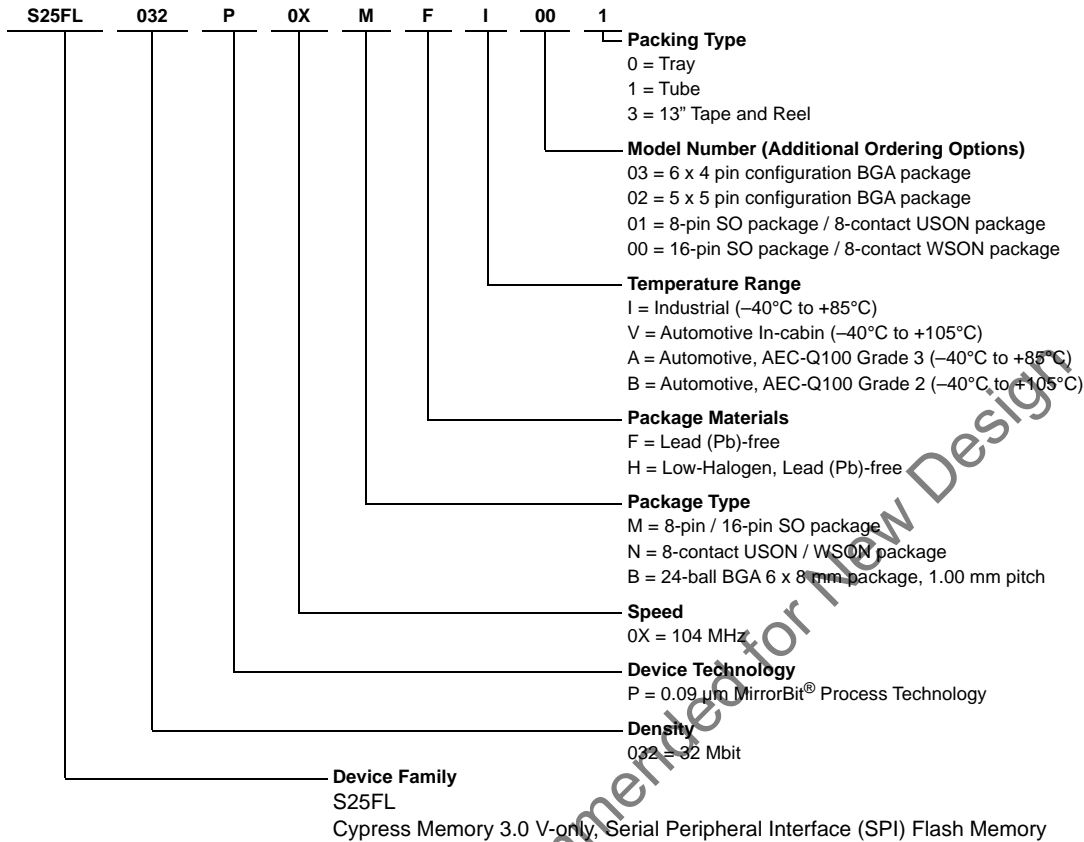

Not Recommended for New Design

5.1 Valid Combinations

Valid Combinations — Standard

Table 2 lists the valid combinations configurations planned to be supported in volume for this device.

Table 2. S25FL032P Valid Combinations

| Base Ordering Part Number | Speed Option | Package and Temperature | Model Number | Packing Type | Package Marking |
|---------------------------|--------------|-------------------------|--------------|--------------|---------------------|
| S25FL032P | 0X | MFI, NFI | 00, 01 | 0, 1, 3 | FL032P + (Temp) + F |
| | | MFV, NFV | | | |
| | | BHI | 02, 03 | 0, 3 | |
| | | BHV | | | |

Valid Combinations — Automotive Grade / AEC-Q100

Table 3 lists configurations that are Automotive Grade / AEC-Q100 qualified and are planned to be available in volume. The table will be updated as new combinations are released. Consult your local sales representative to confirm availability of specific combinations and to check on newly released combinations.

Production Part Approval Process (PPAP) support is only provided for AEC-Q100 grade products.

Products to be used in end-use applications that require ISO/TS-16949 compliance must be AEC-Q100 grade products in combination with PPAP. Non-AEC-Q100 grade products are not manufactured or documented in full compliance with ISO/TS-16949 requirements.

AEC-Q100 grade products are also offered without PPAP support for end-use applications that do not require ISO/TS-16949 compliance.

Table 3. S25FL032P Valid Combinations — Automotive Grade / AEC-Q100

| Base Ordering Part Number | Speed Option | Package and Temperature | Model Number | Packing Type | Package Marking |
|---------------------------|--------------|-------------------------|--------------|--------------|---------------------|
| S25FL032P | 0X | MFA, NFA | 00, 01 | 0, 1, 3 | FL032P + (Temp) + F |
| | | MFB, NFB | | | |
| | | BHA, BHB | 02, 03 | 0, 3 | |

6. SPI Modes

A microcontroller can use either of its two SPI modes to control Cypress SPI Flash memory devices:

- CPOL = 0, CPHA = 0 (Mode 0)
- CPOL = 1, CPHA = 1 (Mode 3)

Input data is latched in on the rising edge of SCK, and output data is available from the falling edge of SCK for both modes.

When the bus master is in standby mode, SCK is as shown in Figure 8 for each of the two modes:

- SCK remains at 0 for (CPOL = 0, CPHA = 0 Mode 0)
- SCK remains at 1 for (CPOL = 1, CPHA = 1 Mode 3)

Figure 7. Bus Master and Memory Devices on the SPI Bus

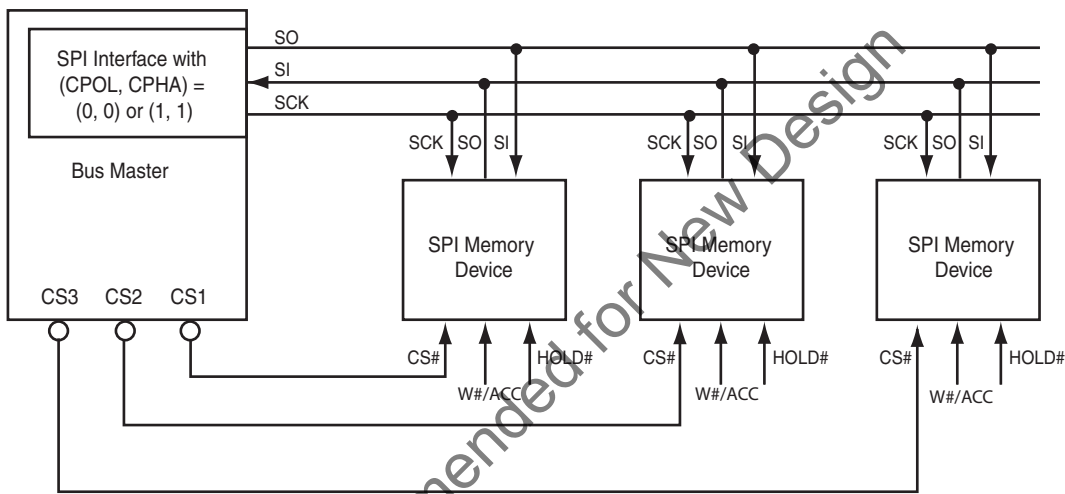

Note

The Write Protect/Accelerated Programming (W#/ACC) and Hold (HOLD#) signals should be driven high (logic level 1) or low (logic level 0) as appropriate.

Figure 8. SPI Modes Supported

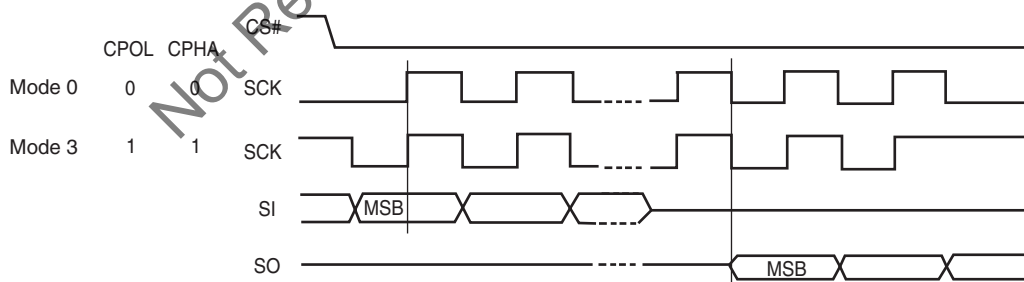

7. Device Operations

All Cypress SPI devices accept and output data in bytes (8 bits at a time). The SPI device is a slave device that supports an inactive clock while CS# is held low.

7.1 Byte or Page Programming

Programming data requires two commands: Write Enable (WREN), which is one byte, and a Page Program (PP) sequence, which consists of four bytes plus data. The Page Program sequence accepts from 1 byte up to 256 consecutive bytes of data (which is the size of one page) to be programmed in one operation. Programming means that bits can either be left at 0, or programmed from 1 to 0. Changing bits from 0 to 1 requires an erase operation.

7.2 Quad Page Programming

The Quad Page Program (QPP) instruction allows up to 256 bytes of data to be programmed using 4 pins as inputs at the same time, thus effectively quadrupling the data transfer rate, compared to the Page Program (PP) instruction. The Write Enable Latch (WEL) bit must be set to a 1 using the Write Enable (WREN) command prior to issuing the QPP command.

7.3 Dual and Quad I/O Mode

The S25FL032P device supports Dual and Quad I/O operation when using the Dual/Quad Output Read Mode and the Dual/Quad I/O High Performance Mode instructions. Using the Dual or Quad I/O instructions allows data to be transferred to or from the device at two to four times the rate of standard SPI devices. When operating in the Dual or Quad I/O High Performance Mode (BBh or EBh instructions), data can be read at fast speed using two or four data bits at a time, and the 3-byte address can be input two or four address bits at a time.

7.4 Sector Erase / Bulk Erase

The Sector Erase (SE) and Bulk Erase (BE) commands set all the bits in a sector or the entire memory array to 1. While bits can be individually programmed from 1 to 0, erasing bits from 0 to 1 must be done on a sector-wide (SE) or array-wide (BE) level. In addition to the 64-KB Sector Erase (SE), the S25FL032P device also offers 4-KB Parameter Sector Erase (P4E) and 8-KB Parameter Sector Erase (P8E).

7.5 Monitoring Write Operations Using the Status Register

The host system can determine when a Write Register, program, or erase operation is complete by monitoring the Write in Progress (WIP) bit in the Status Register. The Read from Status Register command provides the state of the WIP bit. In addition, the S25FL032P device offers two additional bits in the Status Register (P_ERR, E_ERR) to indicate whether a Program or Erase operation was a success or failure.

7.6 Active Power and Standby Power Modes

The device is enabled and in the Active Power mode when Chip Select (CS#) is Low. When CS# is high, the device is disabled, but may still be in the Active Power mode until all program, erase, and Write Registers operations have completed. The device then goes into the Standby Power mode, and power consumption drops to I_{SB} . The Deep Power-Down (DP) command provides additional data protection against inadvertent signals. After writing the DP command, the device ignores any further program or erase commands, and reduces its power consumption to I_{DP} .

7.7 Status Register

The Status Register contains the status and control bits that can be read or set by specific commands (see [Table 10 on page 18](#)). These bits configure different protection configurations and supply information of operation of the device. (for details see [Table 17 on page 30](#)):

- **Write In Progress (WIP):** Indicates whether the device is performing a Write Registers, program or erase operation.
- **Write Enable Latch (WEL):** Indicates the status of the internal Write Enable Latch.
- **Block Protect (BP2, BP1, BP0):** Nonvolatile bits that define memory area to be software-protected against program and erase commands.
- **Erase Error (E_ERR):** The Erase Error Bit is used as an Erase operation success and failure check.
- **Program Error (P_ERR):** The Program Error Bit is used as an program operation success and failure check.
- **Status Register Write Disable (SRWD):** Places the device in the Hardware Protected mode when this bit is set to 1 and the W#/ACC input is driven low. In this mode, the non-volatile bits of the Status Register (SRWD, BP2, BP1, BP0) become read-only bits.

7.8 Configuration Register

The Configuration Register contains the control bits that can be read or set by specific commands. These bits configure different configurations and security features of the device.

- The FREEZE bit locks the BP2-0 bits in Status Register and the TBPROT and TBPARM bits in the Configuration Register. Note that once the FREEZE bit has been set to '1', then it cannot be cleared to '0' until a power-on-reset is executed. As long as the FREEZE bit is set to '0', then the other bits of the Configuration Register, including FREEZE bit, can be written to.
- The QUAD bit is nonvolatile and sets the pin out of the device to Quad mode; that is, W#/ACC becomes IO2 and HOLD# becomes IO3. The instructions for Serial, Dual Output, and Dual I/O reads function as normal. The W#/ACC and HOLD# functionality does not work when the device is set in Quad mode.
- The TBPARM bit defines the logical location of the 4 KB parameter sectors. The parameter sectors consist of thirty two 4 KB sectors. All sectors other than the parameter sectors are defined to be 64-KB uniform in size. When TBPARM is set to a '1', the 4-KB parameter sectors starts at the top of the array. When TBPARM is set to a '0', the 4-KB parameter sectors starts at the bottom of the array. Note that once this bit is set to a '1', it cannot be changed back to '0'.
- The BPNV bit defines whether or not the BP2-0 bits in the Status Register are volatile or non-volatile. When BPNV is set to a '1', the BP2-0 bits in the Status Register are volatile and will be reset to binary 111 after power on reset. When BPNV is set to a '0', the BP2-0 bits in the Status Register are non-volatile. Note that once this bit is set to a '1', it cannot be changed back to '0'.
- The TBPROT bit defines the operation of the block protection bits BP2, BP1, and BP0 in the Status Register. When TBPROT is set to a '0', then the block protection is defined to start from the top of the array. When TBPROT is set to a '1', then the block protection is defined to start from the bottom of the array. Note that once this bit is set to a '1', it cannot be changed back to '0'.

Note: It is suggested that the Block Protection and Parameter sectors not be set to the same area of the array; otherwise, the user cannot utilize the Parameter sectors if they are protected. The following matrix shows the recommended settings.

Table 4. Suggested Cross Settings

| TBPARM | TBPROT | Array Overview |
|--------|--------|--|
| 0 | 0 | Parameter Sectors – Bottom BP Protection – Top (default) |
| 0 | 1 | Not recommended (Parameters & BP Protection are both Bottom) |
| 1 | 0 | Not recommended (parameters & BP Protection are both Top) |
| 1 | 1 | Parameter Sectors - Top of Array (high address) BP Protection - Bottom of Array (low address) |

Table 5. Configuration Register Table

| Bit | Bit Name | Bit Function | Description |
|-----|----------|--|--|
| 7 | NA | – | Not Used |
| 6 | NA | – | Not Used |
| 5 | TBPROT | Configures start of block protection | 1 = Bottom Array (low address) 0 = Top Array (high address) (Default) |
| 4 | NA | – | Do not use |
| 3 | BPV | Configures BP2-0 bits in the Status Register | 1 = Volatile 0 = Nonvolatile (Default) |
| 2 | TBPARAM | Configures Parameter sector location | 1 = Top Array (high address) 0 = Bottom Array (low address) (Default) |
| 1 | QUAD | Puts the device into Quad I/O mode | 1 = Quad I/O 0 = Dual or Serial I/O (Default) |
| 0 | FREEZE | Locks BP2-0 bits in the Status Register | 1 = Enabled 0 = Disabled (Default) |

Note
(Default) indicates the value of each Configuration Register bit set upon initial factory shipment.

7.9 Data Protection Modes

Cypress SPI Flash memory devices provide the following data protection methods:

- **The Write Enable (WREN) command:** Must be written prior to any command that modifies data. The WREN command sets the Write Enable Latch (WEL) bit. The WEL bit resets (disables writes) on power-up or after the device completes the following commands:
 - Page Program (PP)
 - Sector Erase (SE)
 - Bulk Erase (BE)
 - Write Disable (WRDI)
 - Write Register (WRR)
 - Parameter 4 KB Sector Erase (P4E)
 - Parameter 8 KB Sector Erase (P8E)
 - Quad Page Programming (QPP)
 - OTP Byte Programming (OTPP)
- **Software Protected Mode (SPM):** The Block Protect (BP2, BP1, BP0) bits define the section of the memory array that can be read but not programmed or erased. [Table 6](#) and [Table 7](#) shows the sizes and address ranges of protected areas that are defined by Status Register bits BP2:BP0.
- **Hardware Protected Mode (HPM):** The Write Protect (W#/ACC) input and the Status Register Write Disable (SRWD) bit together provide write protection.
- **Clock Pulse Count:** The device verifies that all program, erase, and Write Register commands consist of a clock pulse count that is a multiple of eight before executing them.

Table 6. TBPROT = 0 (Starts Protection from TOP of Array)

| Status Register Block | | | Memory Array | | | | Protected Portion of Total Memory Area |
|-----------------------|-----|-----|-------------------------|-------------------|---------------------------|---------------------|--|
| BP2 | BP1 | BP0 | Protected Address Range | Protected Sectors | Unprotected Address Range | Unprotected Sectors | |
| 0 | 0 | 0 | None | 0 | 000000h-3FFFFFFh | SA63:SA0 | 0 |
| 0 | 0 | 1 | 3F0000h-3FFFFFFh | (1) SA63 | 000000h-3EFFFFh | SA62:SA0 | 1/64 |
| 0 | 1 | 0 | 3E0000h-3FFFFFFh | (2) SA63:SA62 | 000000h-3DFFFFh | SA61:SA0 | 1/32 |
| 0 | 1 | 1 | 3C0000h-3FFFFFFh | (4) SA63:SA60 | 000000h-3BFFFFh | SA59:SA0 | 1/16 |
| 1 | 0 | 0 | 380000h-3FFFFFFh | (8) SA63:SA56 | 000000h-37FFFFh | SA55:SA0 | 1/8 |
| 1 | 0 | 1 | 300000h-3FFFFFFh | (16) SA63:SA48 | 000000h-2FFFFFFh | SA47:SA0 | 1/4 |
| 1 | 1 | 0 | 200000h-3FFFFFFh | (32) SA63:SA32 | 000000h-1FFFFFFh | SA31:SA0 | 1/2 |
| 1 | 1 | 1 | 000000h-3FFFFFFh | (64) SA63:SA0 | None | None | All |

Table 7. TBPROT=1 (Starts Protection from BOTTOM of Array)

| Status Register Block | | | Memory Array | | | | Protected Portion of Total Memory Area |
|-----------------------|-----|-----|-------------------------|-------------------|---------------------------|---------------------|--|
| BP2 | BP1 | BP0 | Protected Address Range | Protected Sectors | Unprotected Address Range | Unprotected Sectors | |
| 0 | 0 | 0 | None | 0 | 000000h-3FFFFFFh | SA0:SA63 | 0 |
| 0 | 0 | 1 | 000000h-00FFFFh | (1) SA0 | 040000h-3FFFFFFh | SA1:SA63 | 1/64 |
| 0 | 1 | 0 | 000000h-01FFFFh | (2) SA0:SA1 | 020000h-3FFFFFFh | SA2:SA63 | 1/32 |
| 0 | 1 | 1 | 000000h-03FFFFh | (4) SA0:SA3 | 040000h-3FFFFFFh | SA4:SA63 | 1/16 |
| 1 | 0 | 0 | 000000h-07FFFFh | (8) SA0:SA7 | 080000h-3FFFFFFh | SA8:SA63 | 1/8 |
| 1 | 0 | 1 | 000000h-0FFFFFFh | (16) SA0:SA15 | 100000h-3FFFFFFh | SA16:SA63 | 1/4 |
| 1 | 1 | 0 | 000000h-1FFFFFFh | (32) SA0:SA31 | 200000h-3FFFFFFh | SA32:SA63 | 1/2 |
| 1 | 1 | 1 | 000000h-3FFFFFFh | (64) SA0:SA63 | None | None | ALL |

7.10 Hold Mode (HOLD#)

The Hold input (HOLD#) stops any serial communication with the device, but does not terminate any Write Registers, program or erase operation that is currently in progress.

The Hold mode starts on the falling edge of HOLD# if SCK is also low (see Figure 9, standard use). If the falling edge of HOLD# does not occur while SCK is low, the Hold mode begins after the next falling edge of SCK (non-standard use).

The Hold mode ends on the rising edge of HOLD# signal (standard use) if SCK is also low. If the rising edge of HOLD# does not occur while SCK is low, the Hold mode ends on the next falling edge of CLK (non-standard use) See Figure 9.

The SO output is high impedance, and the SI and SCK inputs are ignored (don't care) for the duration of the Hold mode.

CS# must remain low for the entire duration of the Hold mode to ensure that the device internal logic remains unchanged. If CS# goes high while the device is in the Hold mode, the internal logic is reset. To prevent the device from reverting to the Hold mode when device communication is resumed, HOLD# must be held high, followed by driving CS# low.

Note: The HOLD Mode feature is disabled during Quad I/O Mode.

Figure 9. Hold Mode Operation

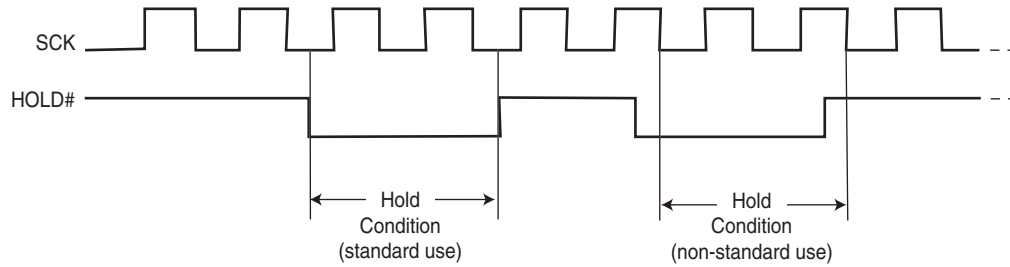

7.11 Accelerated Programming Operation

The device offers accelerated program operations through the ACC function. This function is primarily intended to allow faster manufacturing throughput at the factory. If the system asserts V_{HH} on this pin, the device uses the higher voltage on the pin to reduce the time required for program operations. Removing V_{HH} from the W#/ACC pin returns the device to normal operation. Note that the W#/ACC pin must not be at V_{HH} for operations other than accelerated programming, or device damage may result. In addition, the W#/ACC pin must not be left floating or unconnected; inconsistent behavior of the device may result.

Note: The ACC function is disabled during Quad I/O Mode.

Not Recommended for New Designs

8. Sector Address Table

The Sector Address tables show the size of the memory array, sectors, and pages. The device uses pages to cache the program data before the data is programmed into the memory array. Each page or byte can be individually programmed (bits are changed from 1 to 0). The data is erased (bits are changed from 0 to 1) on a sub-sector, sector- or device-wide basis using the P4E/P8E, SE or BE commands. [Table 8](#) and [Table 9](#) show the starting and ending address for each sector. The complete set of sectors comprises the memory array of the Flash device.

Table 8. S25FL032P Sector Address Table TBPARM=0

| Sector | Address range | | Sector | Address range | | Sector | Address range | |
|--------|---------------|-------------|--------|---------------|-------------|--------|---------------|-------------|
| | Start address | End address | | Start address | End address | | Start address | End address |
| SA63 | 3F0000h | 3FFFFFh | SA31 | 1F0000h | 1FFFFFh | SS31 | 01F000h | 01FFFFh |
| SA62 | 3E0000h | 3EFFFFh | SA30 | 1E0000h | 1EFFFFh | SS30 | 01E000h | 01EFFFh |
| SA61 | 3D0000h | 3DFFFFh | SA29 | 1D0000h | 1DFFFFh | SS29 | 01D000h | 01DFFFh |
| SA60 | 3C0000h | 3CFFFFh | SA28 | 1C0000h | 1CFFFFh | SS28 | 01C000h | 01CFFFh |
| SA59 | 3B0000h | 3BFFFFh | SA27 | 1B0000h | 1BFFFFh | SS27 | 01B000h | 01BFFFh |
| SA58 | 3A0000h | 3AFFFFh | SA26 | 1A0000h | 1AFFFFh | SS26 | 01A000h | 01AFFFh |
| SA57 | 390000h | 39FFFFh | SA25 | 190000h | 19FFFFh | SS25 | 019000h | 019FFFh |
| SA56 | 380000h | 38FFFFh | SA24 | 180000h | 18FFFFh | SS24 | 018000h | 018FFFh |
| SA55 | 370000h | 37FFFFh | SA23 | 170000h | 17FFFFh | SS23 | 017000h | 017FFFh |
| SA54 | 360000h | 36FFFFh | SA22 | 160000h | 16FFFFh | SS22 | 016000h | 016FFFh |
| SA53 | 350000h | 35FFFFh | SA21 | 150000h | 15FFFFh | SS21 | 015000h | 015FFFh |
| SA52 | 340000h | 34FFFFh | SA20 | 140000h | 14FFFFh | SS20 | 014000h | 014FFFh |
| SA51 | 330000h | 33FFFFh | SA19 | 130000h | 13FFFFh | SS19 | 013000h | 013FFFh |
| SA50 | 320000h | 32FFFFh | SA18 | 120000h | 12FFFFh | SS18 | 012000h | 012FFFh |
| SA49 | 310000h | 31FFFFh | SA17 | 110000h | 11FFFFh | SS17 | 011000h | 011FFFh |
| SA48 | 300000h | 30FFFFh | SA16 | 100000h | 10FFFFh | SS16 | 010000h | 010FFFh |
| SA47 | 2F0000h | 2FFFFFh | SA15 | 0F0000h | 0FFFFFh | SS15 | 00F000h | 00FFFFh |
| SA46 | 2E0000h | 2EFFFFh | SA14 | 0E0000h | 0EFFFFh | SS14 | 00E000h | 00EFFFh |
| SA45 | 2D0000h | 2DFFFFh | SA13 | 0D0000h | 0DFFFFh | SS13 | 00D000h | 00DFFFh |
| SA44 | 2C0000h | 2CFFFFh | SA12 | 0C0000h | 0CFFFFh | SS12 | 00C000h | 00CFFFh |
| SA43 | 2B0000h | 2BFFFFh | SA11 | 0B0000h | 0BFFFFh | SS11 | 00B000h | 00BFFFh |
| SA42 | 2A0000h | 2AFFFFh | SA10 | 0A0000h | 0AFFFFh | SS10 | 00A000h | 00AFFFh |
| SA41 | 290000h | 29FFFFh | SA9 | 090000h | 09FFFFh | SS9 | 009000h | 009FFFh |
| SA40 | 280000h | 28FFFFh | SA8 | 080000h | 08FFFFh | SS8 | 008000h | 008FFFh |
| SA39 | 270000h | 27FFFFh | SA7 | 070000h | 07FFFFh | SS7 | 007000h | 007FFFh |
| SA38 | 260000h | 26FFFFh | SA6 | 060000h | 06FFFFh | SS6 | 006000h | 006FFFh |
| SA37 | 250000h | 25FFFFh | SA5 | 050000h | 05FFFFh | SS5 | 005000h | 005FFFh |
| SA36 | 240000h | 24FFFFh | SA4 | 040000h | 04FFFFh | SS4 | 004000h | 004FFFh |
| SA35 | 230000h | 23FFFFh | SA3 | 030000h | 03FFFFh | SS3 | 003000h | 003FFFh |
| SA34 | 220000h | 22FFFFh | SA2 | 020000h | 02FFFFh | SS2 | 002000h | 002FFFh |
| SA33 | 210000h | 21FFFFh | SA1 | 010000h | 01FFFFh | SS1 | 001000h | 001FFFh |
| SA32 | 200000h | 20FFFFh | SA0 | 000000h | 00FFFFh | SS0 | 000000h | 000FFFh |

Note

Sector SA0 is split up into sub-sectors SS0 - SS15 (dark gray shading).
Sector SA1 is split up into sub-sectors SS16 - SS31 (light gray shading).

Table 9. S25FL032P Sector Address Table TBPARM=1

| Sector | Address Range | | Sector | Address Range | | Sector | Address Range | |
|--------|---------------|-------------|--------|---------------|-------------|--------|---------------|-------------|
| | Start Address | End Address | | Start Address | End Address | | Start Address | End Address |
| SS31 | 3FF000h | 3FFFFFFh | SA63 | 3F0000h | 3FFFFFFh | SA31 | 1F0000h | 1FFFFFFh |
| SS30 | 3FE000h | 3FEFFFh | SA62 | 3E0000h | 3EFFFFh | SA30 | 1E0000h | 1EFFFFh |
| SS29 | 3FD000h | 3FDFFFh | SA61 | 3D0000h | 3DFFFFh | SA29 | 1D0000h | 1DFFFFh |
| SS28 | 3FC000h | 3FCFFFh | SA60 | 3C0000h | 3CFFFFh | SA28 | 1C0000h | 1CFFFFh |
| SS27 | 3FB000h | 3FBFFFh | SA59 | 3B0000h | 3BFFFFh | SA27 | 1B0000h | 1BFFFFh |
| SS26 | 3FA000h | 3FAFFFh | SA58 | 3A0000h | 3AFFFFh | SA26 | 1A0000h | 1AFFFFh |
| SS25 | 3F9000h | 3F9FFFh | SA57 | 390000h | 39FFFFh | SA25 | 190000h | 19FFFFh |
| SS24 | 3F8000h | 3F8FFFh | SA56 | 380000h | 38FFFFh | SA24 | 180000h | 18FFFFh |
| SS23 | 3F7000h | 3F7FFFh | SA55 | 370000h | 37FFFFh | SA23 | 170000h | 17FFFFh |
| SS22 | 3F6000h | 3F6FFFh | SA54 | 360000h | 36FFFFh | SA22 | 160000h | 16FFFFh |
| SS21 | 3F5000h | 3F5FFFh | SA53 | 350000h | 35FFFFh | SA21 | 150000h | 15FFFFh |
| SS20 | 3F4000h | 3F4FFFh | SA52 | 340000h | 34FFFFh | SA20 | 140000h | 14FFFFh |
| SS19 | 3F3000h | 3F3FFFh | SA51 | 330000h | 33FFFFh | SA19 | 130000h | 13FFFFh |
| SS18 | 3F2000h | 3F2FFFh | SA50 | 320000h | 32FFFFh | SA18 | 120000h | 12FFFFh |
| SS17 | 3F1000h | 3F1FFFh | SA49 | 310000h | 31FFFFh | SA17 | 110000h | 11FFFFh |
| SS16 | 3F0000h | 3F0FFFh | SA48 | 300000h | 30FFFFh | SA16 | 100000h | 10FFFFh |
| SS15 | 3EF000h | 3EFFFFh | SA47 | 2F0000h | 2EFFFFh | SA15 | 0F0000h | 0EFFFFh |
| SS14 | 3EE000h | 3EFFFh | SA46 | 2E0000h | 2EFFFFh | SA14 | 0E0000h | 0EFFFFh |
| SS13 | 3ED000h | 3EDFFFh | SA45 | 2D0000h | 2DFFFFh | SA13 | 0D0000h | 0DFFFFh |
| SS12 | 3EC000h | 3ECFFFh | SA44 | 2C0000h | 2CFFFFh | SA12 | 0C0000h | 0CFFFFh |
| SS11 | 3EB000h | 3EBFFFh | SA43 | 2B0000h | 2BFFFFh | SA11 | 0B0000h | 0BFFFFh |
| SS10 | 3EA000h | 3EAFFFh | SA42 | 2A0000h | 2AFFFFh | SA10 | 0A0000h | 0AFFFFh |
| SS9 | 3E9000h | 3E9FFFh | SA41 | 290000h | 29FFFFh | SA9 | 090000h | 09FFFFh |
| SS8 | 3E8000h | 3E8FFFh | SA40 | 280000h | 28FFFFh | SA8 | 080000h | 08FFFFh |
| SS7 | 3E7000h | 3E7FFFh | SA39 | 270000h | 27FFFFh | SA7 | 070000h | 07FFFFh |
| SS6 | 3E6000h | 3E6FFFh | SA38 | 260000h | 26FFFFh | SA6 | 060000h | 06FFFFh |
| SS5 | 3E5000h | 3E5FFFh | SA37 | 250000h | 25FFFFh | SA5 | 050000h | 05FFFFh |
| SS4 | 3E4000h | 3E4FFFh | SA36 | 240000h | 24FFFFh | SA4 | 040000h | 04FFFFh |
| SS3 | 3E3000h | 3E3FFFh | SA35 | 230000h | 23FFFFh | SA3 | 030000h | 03FFFFh |
| SS2 | 3E2000h | 3E2FFFh | SA34 | 220000h | 22FFFFh | SA2 | 020000h | 02FFFFh |
| SS1 | 3E1000h | 3E1FFFh | SA33 | 210000h | 21FFFFh | SA1 | 010000h | 01FFFFh |
| SS0 | 3E0000h | 3E0FFFh | SA32 | 200000h | 20FFFFh | SA0 | 000000h | 00FFFFh |

Note

Sector SA62 is split up into sub-sectors SS0 - SS15 (dark gray shading).
 Sector SA63 is split up into sub-sectors SS16 - SS31 (light gray shading).

9. Command Definitions

The host system must shift all commands, addresses, and data in and out of the device, beginning with the most significant bit. On the first rising edge of SCK after CS# is driven low, the device accepts the one-byte command on SI (all commands are one byte long), most significant bit first. Each successive bit is latched on the rising edge of SCK. Table 10 lists the complete set of commands.

Every command sequence begins with a one-byte command code. The command may be followed by address, data, both, or nothing, depending on the command. CS# must be driven high after the last bit of the command sequence has been written.

The Read Data Bytes (READ), Read Data Bytes at Higher Speed (FAST_READ), Dual Output Read (DOR), Quad Output Read (QOR), Dual I/O High Performance Read (DIOR), Quad I/O High Performance Read (QIOR), Read Status Register (RDSR), Read Configuration Register (RCR), Read OTP Data (OTPR), Read Manufacturer and Device ID (READ_ID), Read Identification (RDID) and Release from Deep Power-Down and Read Electronic Signature (RES) command sequences are followed by a data output sequence on SO. CS# can be driven high after any bit of the sequence is output to terminate the operation.

The Page Program (PP), Quad Page Program (QPP), 64 KB Sector Erase (SE), 4 KB Parameter Sector Erase (P4E), 8 KB Parameter Sector Erase (P8E), Bulk Erase (BE), Write Status and Configuration Registers (WRR), Program OTP space (OTPP), Write Enable (WREN), or Write Disable (WRDI) commands require that CS# be driven high at a byte boundary, otherwise the command is not executed. Since a byte is composed of eight bits, CS# must therefore be driven high when the number of clock pulses after CS# is driven low is an exact multiple of eight.

The device ignores any attempt to access the memory array during a Write Registers, program, or erase operation, and continues the operation uninterrupted. The instruction set is listed in Table 10.

Table 10. Instruction Set

| Operation | Command | One Byte Command Code | Description | Address Byte Cycle | Mode Bit Cycle | Dummy Byte Cycle | Data Byte Cycle |
|---------------|-----------|---------------------------------------|---|--------------------|----------------|------------------|-----------------|
| Read | READ | (03h) 0000 0011 | Read Data bytes | 3 | 0 | 0 | 1 to ∞ |
| | FAST_READ | (0Bh) 0000 1011 | Read Data bytes at Fast Speed | 3 | 0 | 1 | 1 to ∞ |
| | DOR | (3Bh) 0011 1011 | Dual Output Read | 3 | 0 | 1 | 1 to ∞ |
| | QOR | (6Bh) 0110 1011 | Quad Output Read | 3 | 0 | 1 | 1 to ∞ |
| | DIOR | (BBh) 1011 1011 | Dual I/O High Performance Read | 3 | 1 | 0 | 1 to ∞ |
| | QIOR | (EBh) 1110 1011 | Quad I/O High Performance Read | 3 | 1 | 2 | 1 to ∞ |
| | RDID | (9Fh) 1001 1111 | Read Identification | 0 | 0 | 0 | 1 to 81 |
| | READ_ID | (90h) 1001 0000 | Read Manufacturer and Device Identification | 3 | 0 | 0 | 1 to ∞ |
| Write Control | WREN | (06h) 0000 0110 | Write Enable | 0 | 0 | 0 | 0 |
| | WRDI | (04h) 0000 0100 | Write Disable | 0 | 0 | 0 | 0 |
| Erase | P4E | (20h) 0010 0000 | 4-KB Parameter Sector Erase | 3 | 0 | 0 | 0 |
| | P8E | (40h) 0100 0000 | 8-KB (two 4KB) Parameter Sector Erase | 3 | 0 | 0 | 0 |
| | SE | (D8h) 1101 1000 | 64-KB Sector Erase | 3 | 0 | 0 | 0 |
| | BE | (60h) 0110 0000 or (C7h) 1100 0111 | Bulk Erase | 0 | 0 | 0 | 0 |
| Program | PP | (02h) 0000 0010 | Page Programming | 3 | 0 | 0 | 1 to 256 |
| | QPP | (32h) 0011 0010 | Quad Page Programming | 3 | 0 | 0 | 1 to 256 |

Table 10. Instruction Set (Continued)

| Operation | Command | One Byte Command Code | Description | Address Byte Cycle | Mode Bit Cycle | Dummy Byte Cycle | Data Byte Cycle |
|---------------------------------|---------|-----------------------|---|--------------------|----------------|------------------|-----------------|
| Status & Configuration Register | RDSR | (05h) 0000 0101 | Read Status Register | 0 | 0 | 0 | 1 to ∞ |
| | WRR | (01h) 0000 0001 | Write (Status & Configuration) Register | 0 | 0 | 0 | 1 to 2 |
| | RCR | (35h) 0011 0101 | Read Configuration Register (CFG) | 0 | 0 | 0 | 1 to ∞ |
| | CLSR | (30h) 0011 0000 | Reset the Erase and Program Fail Flag (SR5 and SR6) and restore normal operation) | 0 | 0 | 0 | 0 |
| Power Saving | DP | (B9h) 1011 1001 | Deep Power-Down | 0 | 0 | 0 | 0 |
| | RES | (ABh) 1010 1011 | Release from Deep Power-Down Mode | 0 | 0 | 0 | 0 |
| | | (ABh) 1010 1011 | Release from Deep Power-Down and Read Electronic Signature | 0 | 0 | 3 | 1 to ∞ |
| OTP | OTPP | (42h) 0100 0010 | Program one byte of data in OTP memory space | 3 | 0 | 0 | 1 |
| | OTPR | (4Bh) 0100 1011 | Read data in the OTP memory space | 3 | 0 | 1 | 1 to ∞ |

Not Recommended for New Design

9.1 Read Data Bytes (READ)

The Read Data Bytes (READ) command reads data from the memory array at the frequency (f_R) presented at the SCK input, with a maximum speed of 40 MHz. The host system must first select the device by driving CS# low. The READ command is then written to SI, followed by a 3 byte address (A23-A0). Each bit is latched on the rising edge of SCK. The memory array data, at that address, are output serially on SO at a frequency f_R , on the falling edge of SCK.

Figure 10 and Table 10 on page 18 detail the READ command sequence. The first address byte specified can start at any location of the memory array. The device automatically increments to the next higher address after each byte of data is output. The entire memory array can therefore be read with a single READ command. When the highest address is reached, the address counter reverts to 00000h, allowing the read sequence to continue indefinitely.

The READ command is terminated by driving CS# high at any time during data output. The device rejects any READ command issued while it is executing a program, erase, or Write Registers operation, and continues the operation uninterrupted.

Figure 10. Read Data Bytes (READ) Command Sequence

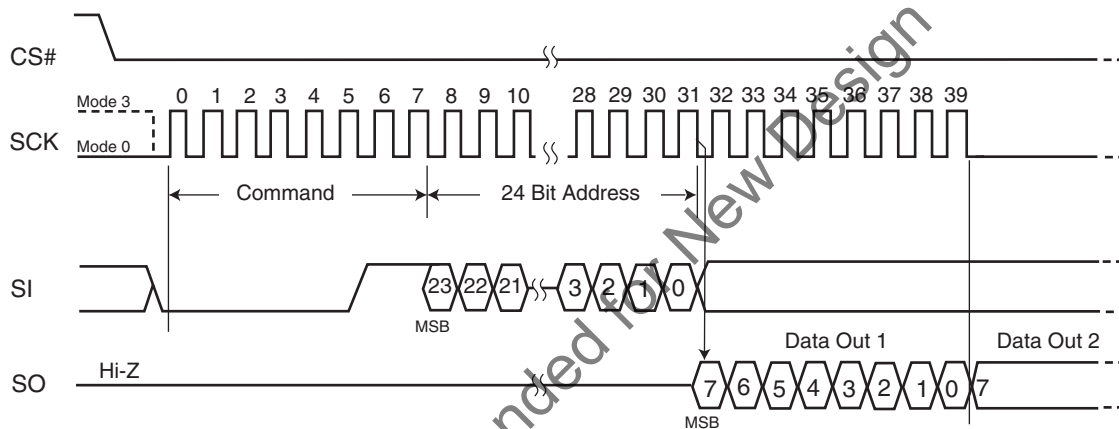

9.2 Read Data Bytes at Higher Speed (FAST_READ)

The FAST_READ command reads data from the memory array at the frequency (f_C) presented at the SCK input, with a maximum speed of 104 MHz. The host system must first select the device by driving CS# low. The FAST_READ command is then written to SI, followed by a 3 byte address (A23-A0) and a dummy byte. Each bit is latched on the rising edge of SCK. The memory array data, at that address, are output serially on SO at a frequency f_C , on the falling edge of SCK.

The FAST_READ command sequence is shown in Figure 11 and Table 10 on page 18. The first address byte specified can start at any location of the memory array. The device automatically increments to the next higher address after each byte of data is output. The entire memory array can therefore be read with a single FAST_READ command. When the highest address is reached, the address counter reverts to 00000h, allowing the read sequence to continue indefinitely.

The FAST_READ command is terminated by driving CS# high at any time during data output. The device rejects any FAST_READ command issued while it is executing a program, erase, or Write Registers operation, and continues the operation uninterrupted.

Figure 11. Read Data Bytes at Higher Speed (FAST_READ) Command Sequence

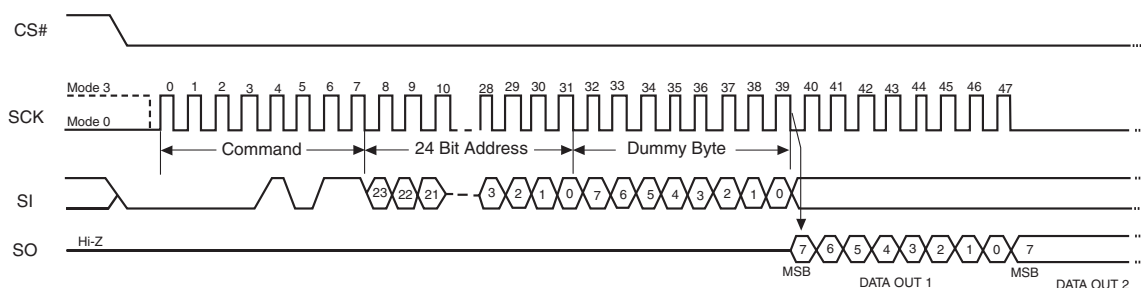

9.3 Dual Output Read Mode (DOR)

The Dual Output Read instruction is similar to the FAST_READ instruction, except that the data is shifted out 2 bits at a time using 2 pins (SI/IO0 and SO/IO1) instead of 1 bit, at a maximum frequency of 80 MHz. The Dual Output Read mode effectively doubles the data transfer rate compared to the FAST_READ instruction.

The host system must first select the device by driving CS# low. The Dual Output Read command is then written to SI, followed by a 3-byte address (A23-A0) and a dummy byte. Each bit is latched on the rising edge of SCK. Then the memory contents, at the address that is given, are shifted out two bits at a time through the IO0 (SI) and IO1 (SO) pins at a frequency f_C on the falling edge of SCK.

The Dual Output Read command sequence is shown in Figure 12 and Table 10 on page 18. The first address byte specified can start at any location of the memory array. The device automatically increments to the next higher address after each byte of data is output. The entire memory array can therefore be read with a single Dual Output Read command. When the highest address is reached, the address counter reverts to 00000h, allowing the read sequence to continue indefinitely.

It is important that the I/O pins be set to high-impedance prior to the falling edge of the first data out clock.

The Dual Output Read command is terminated by driving CS# high at any time during data output. The device rejects any Dual Output Read command issued while it is executing a program, erase, or Write Registers operation, and continues the operation uninterrupted.

Figure 12. Dual Output Read Instruction Sequence

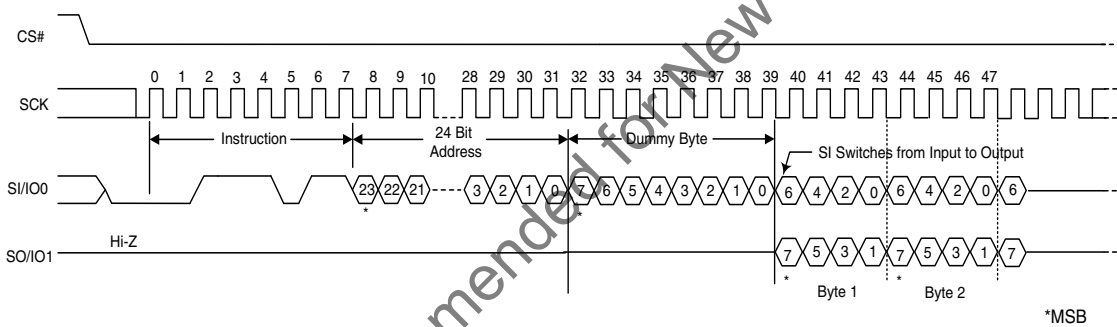

9.4 Quad Output Read Mode (QOR)

The Quad Output Read instruction is similar to the FAST_READ instruction, except that the data is shifted out 4 bits at a time using 4 pins (SI/IO0, SO/IO1, W#/ACC/IO2 and HOLD#/IO3) instead of 1 bit, at a maximum frequency of 80 MHz. The Quad Output Read mode effectively doubles the data transfer rate compared to the Dual Output Read instruction, and is four times the data transfer rate of the FAST_READ instruction.

The host system must first select the device by driving CS# low. The Quad Output Read command is then written to SI, followed by a 3-byte address (A23-A0) and a dummy byte. Each bit is latched on the rising edge of SCK. Then the memory contents, at the address that are given, are shifted out four bits at a time through IO0 (SI), IO1 (SO), IO2 (W#/ACC), and IO3 (HOLD#) pins at a frequency f_C on the falling edge of SCK.

The Quad Output Read command sequence is shown in Figure 13 and Table 10 on page 18. The first address byte specified can start at any location of the memory array. The device automatically increments to the next higher address after each byte of data is output. The entire memory array can therefore be read with a single Quad Output Read command. When the highest address is reached, the address counter reverts to 00000h, allowing the read sequence to continue indefinitely.

It is important that the I/O pins be set to high-impedance prior to the falling edge of the first data out clock.

The Quad Output Read command is terminated by driving CS# high at any time during data output. The device rejects any Quad Output Read command issued while it is executing a program, erase, or Write Registers operation, and continues the operation uninterrupted.

The Quad bit of Configuration Register must be set (CR Bit1 = 1) to enable the Quad mode capability of the S25FL device.

Figure 13. Quad Output Read Instruction Sequence

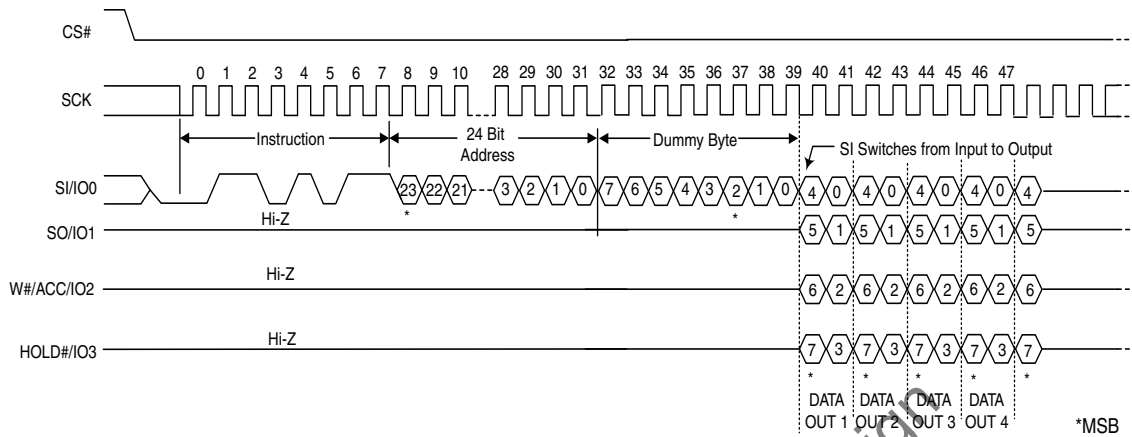

9.5 DUAL I/O High Performance Read Mode (DIOR)

The Dual I/O High Performance Read instruction is similar to the Dual Output Read instruction, except that it improves throughput by allowing input of the address bits (A23-A0) using 2 bits per SCK via two input pins (SI/IO2 and SO/IO1), at a maximum frequency of 80 MHz.

The host system must first select the device by driving CS# low. The Dual I/O High Performance Read command is then written to SI, followed by a 3-byte address (A23-A0) and a 1-byte Mode instruction, with two bits latched on the rising edge of SCK. Then the memory contents, at the address that is given, are shifted out two bits at a time through IO0 (SI) and IO1 (SO).

The DUAL I/O High Performance Read command sequence is shown in Figure 14 and Table 10 on page 18. The first address byte specified can start at any location of the memory array. The device automatically increments to the next higher address after each byte of data is output. The entire memory array can therefore be read with a single DUAL I/O High Performance Read command. When the highest address is reached, the address counter reverts to 00000h, allowing the read sequence to continue indefinitely.

In addition, address jumps can be done without exiting the Dual I/O High Performance Mode through the setting of the Mode bits (after the Address (A23-0) sequence, as shown in Figure 14). This added feature removes the need for the instruction sequence and greatly improves code execution (XIP). The upper nibble (bits 7-4) of the Mode bits control the length of the next Dual I/O High Performance instruction through the inclusion or exclusion of the first byte instruction code. The lower nibble (bits 3-0) of the Mode bits are DON'T CARE ("x"). If the Mode bits equal Axh, then the device remains in Dual I/O High Performance Read Mode and the next address can be entered (after CS# is raised high and then asserted low) without requiring the BBh instruction opcode, as shown in Figure 15, thus eliminating eight cycles for the instruction sequence. However, if the Mode bits are any value other than Axh, then the next instruction (after CS# is raised high and then asserted low) requires the instruction sequence, which is normal operation. The following sequences will release the device from Dual I/O High Performance Read mode; after which, the device can accept standard SPI instructions:

1. During the Dual I/O High Performance Instruction Sequence, if the Mode bits are any value other than Axh, then the next time CS# is raised high and then asserted low, the device will be released from Dual I/O High Performance Read mode.
2. Furthermore, during any operation, if CS# toggles high to low to high for eight cycles (or less) **and** data input (IO0 and IO1) are not set for a valid instruction sequence, then the device will be released from Dual I/O High Performance Read mode.

It is important that the I/O pins be set to high-impedance prior to the falling edge of the first data out clock.

The read instruction can be terminated by driving the CS# pin to the logic high state. The CS# pin can be driven high at any time during data output to terminate a read operation.

Figure 14. DUAL I/O High Performance Read Instruction Sequence

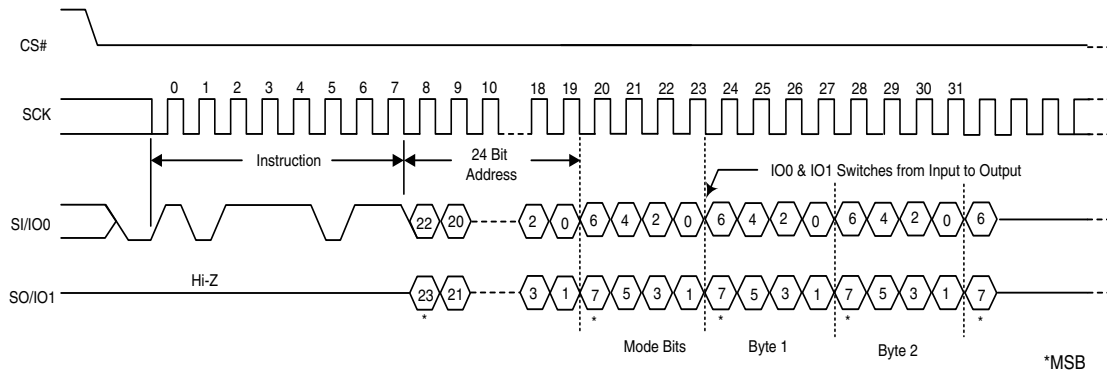
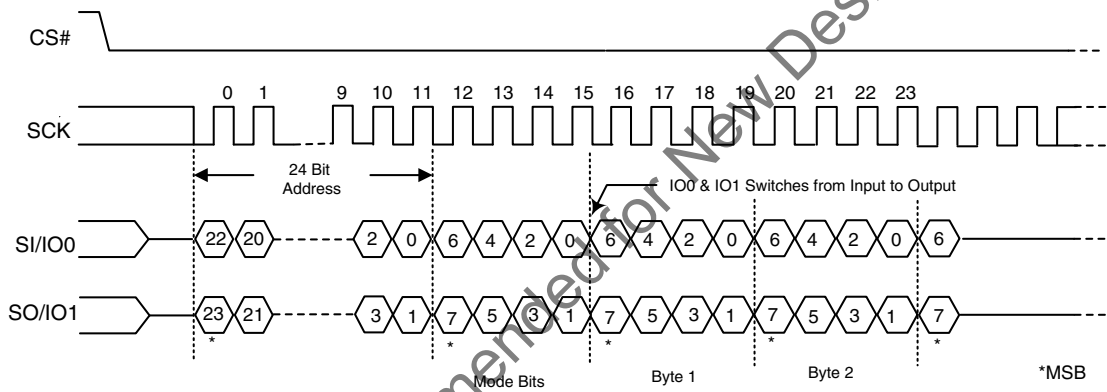

Figure 15. Continuous Dual I/O High Performance Read Instruction Sequence



9.6 Quad I/O High Performance Read Mode (QIOR)

The Quad I/O High Performance Read instruction is similar to the Quad Output Read instruction, except that it further improves throughput by allowing input of the address bits (A23-A0) using 4 bits per SCK via four input pins (SI/IO0, SO/IO1, W#/ACC/IO2, and HOLD#/IO3), at a maximum frequency of 80 MHz.

The host system must first select the device by driving CS# low. The Quad I/O High Performance Read command is then written to SI, followed by a 3-byte address (A23-A0) and a 1-byte Mode instruction, with four bits latched on the rising edge of SCK. Note that four dummy clocks are required prior to the data input. Then the memory contents, at the address that is given, are shifted out four bits at a time through IO0 (SI), IO1 (SO), IO2 (W#/ACC), and IO3 (HOLD#).

The Quad I/O High Performance Read command sequence is shown in Figure 16 and Table 10 on page 18. The first address byte specified can start at any location of the memory array. The device automatically increments to the next higher address after each byte of data is output. The entire memory array can therefore be read with a single Quad I/O High Performance Read command. When the highest address is reached, the address counter reverts to 00000h, allowing the read sequence to continue indefinitely.

In addition, address jumps can be done without exiting the Quad I/O High Performance Mode through the setting of the Mode bits (after the Address (A23-0) sequence, as shown in Figure 16). This added feature removes the need for the instruction sequence and greatly improves code execution (XIP). The upper nibble (bits 7-4) of the Mode bits control the length of the next Quad I/O High Performance instruction through the inclusion or exclusion of the first byte instruction code. The lower nibble (bits 3-0) of the Mode bits are DON'T CARE ("x"). If the Mode bits equal Axh, then the device remains in Quad I/O High Performance Read Mode and the next address can be entered (after CS# is raised high and then asserted low) without requiring the EBh instruction opcode, as shown in Figure 17, thus eliminating eight cycles for the instruction sequence.

The following sequences will release the device from Quad I/O High Performance Read mode; after which, the device can accept standard SPI instructions:

1. During the Quad I/O High Performance Instruction Sequence, if the Mode bits are any value other than Axh, then the next time CS# is raised high and then asserted low the device will be released from Quad I/O High Performance Read mode.
2. Furthermore, during any operation, if CS# toggles high to low to high for eight cycles (or less) **and** data input (IO0, IO1, IO2, & IO3) are not set for a valid instruction sequence, then the device will be released from Quad I/O High Performance Read mode.

It is important that the I/O pins be set to high-impedance prior to the falling edge of the first data out clock.

The read instruction can be terminated by driving the CS# pin to the logic high state. The CS# pin can be driven high at any time during data output to terminate a read operation.

Figure 16. QUAD I/O High Performance Instruction Sequence

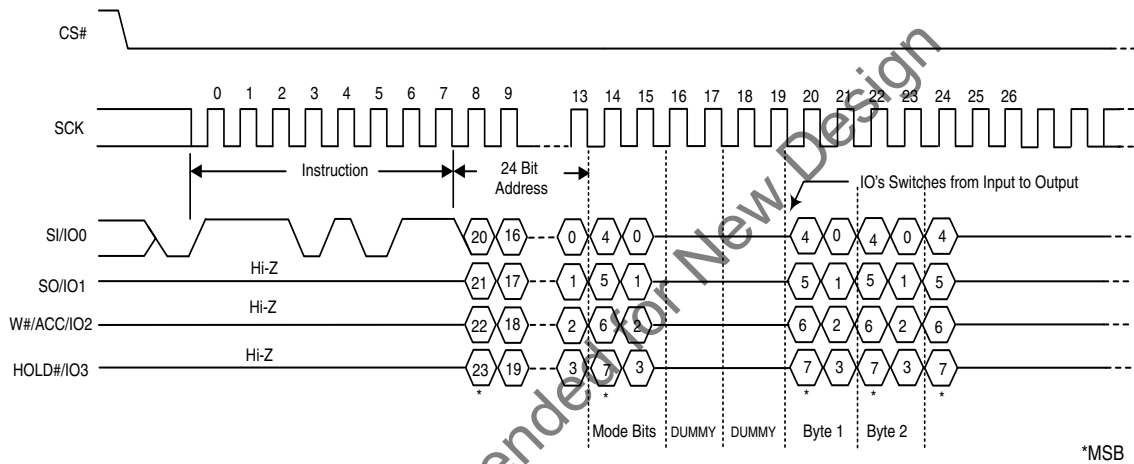
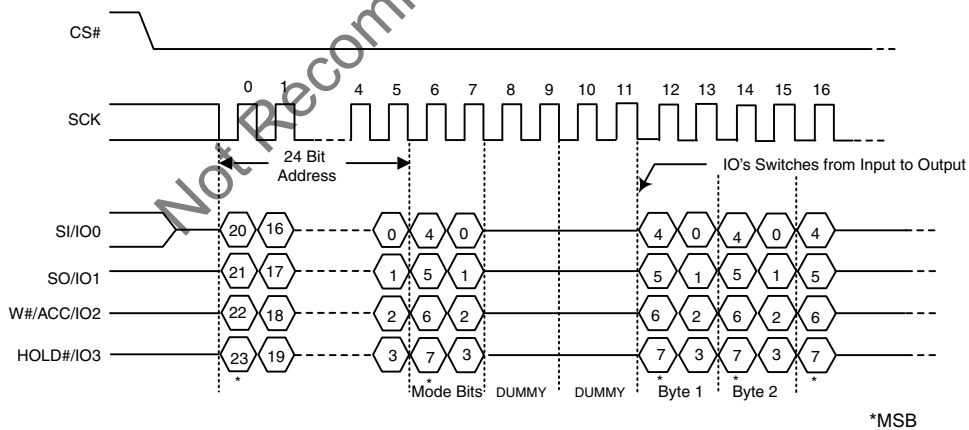

Figure 17. Continuous QUAD I/O High Performance Instruction Sequence



9.7 Read Identification (RDID)

The Read Identification (RDID) command outputs the one-byte manufacturer identification, followed by the two-byte device identification and the bytes for the Common Flash Interface (CFI) tables. The manufacturer identification is assigned by JEDEC; for Cypress devices, it is 01h. The device identification (2 bytes) and CFI bytes are assigned by the device manufacturer.

See [Table 11 on page 25](#) for device ID data.

The Common Flash Interface (CFI) specification outlines device and host system software interrogation handshake, which allows vendor-specified software algorithms to be used for entire families of devices. Software support can then be device-independent, JEDEC ID-independent, and forward- and backward-compatible for the specified flash device families. Flash vendors can standardize their existing interfaces for long-term compatibility. The system can read CFI information at the addresses given in [Table 12](#).

The host system must first select the device by driving CS# low. The RDID command is then written to SI, and each bit is latched on the rising edge of SCK. One byte of manufacture identification, two bytes of device identification and sixty-six bytes of extended device identification are then output from the memory array on SO at a frequency f_R , on the falling edge of SCK. The maximum clock frequency for the RDID (9Fh) command is 50 MHz (Normal Read). The manufacturer ID and Device-ID can be read repeatedly by applying multiples of 648 clock cycles. The manufacturer ID, Device ID and CFI table can be continuously read as long as CS# is held low with a clock input.

The RDID command sequence is shown in [Figure 18](#) and [Table 10 on page 18](#).

Driving CS# high after the device identification data has been read at least once terminates the RDID command. Driving CS# high at any time during data output (for example, while reading the extended CFI bytes), also terminates the RDID operation.

The device rejects any RDID command issued while it is executing a program, erase, or Write Registers operation, and continues the operation uninterrupted.

Figure 18. Read Identification (RDID) Command Sequence and Data-Out Sequence

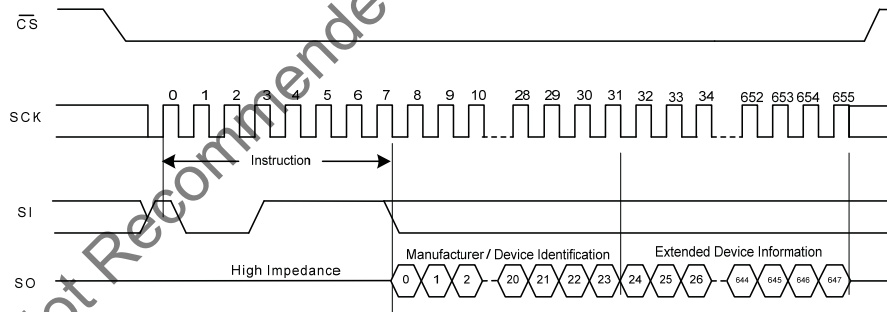

Table 11. Manufacturer & Device ID - RDID (JEDEC 9Fh)

| Device | Manuf. ID | Device Id | | # Extended bytes |
|---------------------|-----------|-----------|--------|------------------|
| | Byte 0 | Byte 1 | Byte 2 | Byte 3 |
| S25FL032P SPI Flash | 01h | 02h | 15h | 4Dh |

Notes

1. Byte 0 is Manufacturer ID of Cypress.
2. Byte 1 & 2 is Device Id.
3. Byte 3 is Extended Device Information String Length, to indicate how many Extended Device Information bytes will follow.
4. Bytes 4, 5 and 6 are Cypress reserved (do not use).
5. For Bytes 07h-0Fh and 3Dh-3Fh, the data will be read as 0xFF.
6. Bytes 10h-50h are factory programmed per JEDEC standard.

Table 12. Product Group CFI Query Identification String

| Byte | Data | Description |
|------|------|---|
| 10h | 51h | Query Unique ASCII string "QRY" |
| 11h | 52h | |
| 12h | 59h | |
| 13h | 02h | Primary OEM Command Set |
| 14h | 00h | |
| 15h | 40h | Address for Primary Extended Table |
| 16h | 00h | |
| 17h | 00h | Alternate OEM Command Set (00h = none exists) |
| 18h | 00h | |
| 19h | 00h | Address for Alternate OEM Extended Table (00h = none exists) |
| 1Ah | 00h | |

Table 13. Product Group CFI System Interface String

| Byte | Data | Description |
|------|------|--|
| 1Bh | 27h | V _{CC} Min. (erase/program): (D7-D4: Volt, D3-D0: 100 mV) |
| 1Ch | 36h | V _{CC} Max. (erase/program): (D7-D4: Volt, D3-D0: 100 mV) |
| 1Dh | 00h | V _{PP} Min. voltage (00h = no VPP pin present) |
| 1Eh | 00h | V _{PP} Max. voltage (00h = no VPP pin present) |
| 1Fh | 0Bh | Typical timeout per single byte program 2 ^N μs |
| 20h | 0Bh | Typical timeout for Min. size Page program 2 ^N μs (00h = not supported) |
| 21h | 09h | Typical timeout per individual sector erase 2 ^N ms |
| 22h | 0Fh | Typical timeout for full chip erase 2 ^N ms (00h = not supported) |
| 23h | 01h | Max. timeout for byte program 2 ^N times typical |
| 24h | 01h | Max. timeout for page program 2 ^N times typical |
| 25h | 02h | Max. timeout per individual sector erase 2 ^N times typical |
| 26h | 01h | Max. timeout for full chip erase 2 ^N times typical (00h = not supported) |

Table 14. Product Group CFI Device Geometry Definition

| Byte | Data | Description |
|------|------|---|
| 27h | 16h | Device Size = 2 ^N byte; |
| 28h | 05h | Flash Device Interface Description; 00h = x8 only 01h = x16 only 02h = x8/x16 capable 03h = x32 only 04h = Single I/O SPI, 3-byte address 05h = Multi I/O SPI, 3-byte address |
| 29h | 05h | |
| 2Ah | 08h | Max. number of bytes in multi-byte write = 2 ^N (00 = not supported) |
| 2Bh | 00h | |
| 2Ch | 02h | Number of Erase Block Regions within device 1 = Uniform Device, 2 = Parameter Block |

Table 14. Product Group CFI Device Geometry Definition (Continued)

| Byte | Data | Description |
|------|------|---|
| 2Dh | 1Fh | Erase Block Region 1 Information (refer to CFI publication 100) |
| 2Eh | 00h | |
| 2Fh | 10h | |
| 30h | 00h | |
| 31h | 3Dh | Erase Block Region 2 Information (refer to CFI publication 100) |
| 32h | 00h | |
| 33h | 00h | |
| 34h | 01h | |
| 35h | 00h | Erase Block Region 3 Information (refer to CFI publication 100) |
| 36h | 00h | |
| 37h | 00h | |
| 38h | 00h | |
| 39h | 00h | Erase Block Region 4 Information (refer to CFI publication 100) |
| 3Ah | 00h | |
| 3Bh | 00h | |
| 3Ch | 00h | |

Table 15. Product Group CFI Primary Vendor-Specific Extended Query

| Byte | Data | Description |
|------|------|---|
| 40h | 50h | Query-unique ASCII string "PRI" |
| 41h | 52h | |
| 42h | 49h | |
| 43h | 31h | Major version number, ASCII |
| 44h | 33h | Minor version number, ASCII |
| 45h | 15h | Address Sensitive Unlock (Bits 1-0) 00b = Required, 01b = Not Required Process Technology (Bits 5-2) 0000b = 0.23 µm Floating Gate 0001b = 0.17 µm Floating Gate 0010b = 0.23 µm MirrorBit 0010b = 0.20 µm MirrorBit 0011b = 0.11 µm Floating Gate 0100b = 0.11 µm MirrorBit 0101b = 0.09 µm MirrorBit 1000b = 0.065 µm MirrorBit |
| 46h | 00h | Erase Suspend 0 = Not Supported, 1 = Read Only, 2 = Read & Write |
| 47h | 01h | Sector Protect 00 = Not Supported, X = Number of sectors in per smallest group |
| 48h | 00h | Temporary Sector Unprotect 00 = Not Supported, 01 = Supported |
| 49h | 05h | Sector Protect/Unprotect Scheme 04 = High Voltage Method 05 = Software Command Locking Method 08 = Advanced Sector Protection Method |
| 4Ah | 00h | Simultaneous Operation 00 = Not Supported, X = Number of Sectors outside Bank 1 |
| 4Bh | 01h | Burst Mode Type 00 = Not Supported, 01 = Supported |

Table 15. Product Group CFI Primary Vendor-Specific Extended Query (Continued)

| Byte | Data | Description |
|------|------|---|
| 4Ch | 03h | Page Mode Type 00 = Not Supported, 01 = 4 Word Page, 02 = 8 Word Page, 03 = 256 Byte Page |
| 4Dh | 85h | ACC (Acceleration) Supply Minimum 00 = Not Supported, (D7-D4: Volt, D3-D0: 100 mV) |
| 4Eh | 95h | ACC (Acceleration) Supply Maximum 00 = Not Supported, (D7-D4: Volt, D3-D0: 100 mV) |
| 4Fh | 07h | W# Protection 07 = Uniform Device with Top or Bottom Write Protect (user select) |
| 50h | 00h | Program Suspend 00 = Not Supported, 01 = Supported |

Note

CFI data related to V_{CC} and time-outs may differ from actual V_{CC} and time-outs of the product. Please consult the Ordering Information tables to obtain the V_{CC} range for particular part numbers. Refer to Section 18., AC Characteristics on page 49 for typical timeout specifications.

9.8 Read-ID (READ_ID)

The READ_ID instruction provides the S25FL032P manufacturer and device information and is provided as an alternative to the Release from Deep Power-Down and Read Electronic Signature (RES), and the JEDEC Read Identification (RDID) commands.

The instruction is initiated by driving the CS# pin low and shifting in (via the SI input pin) the instruction code “90h” followed by a 24-bit address (which is either 00000h or 00001h). Following this, the Manufacturer ID and the Device ID are shifted out on the SO output pin starting after the falling edge of the SCK serial clock input signal. If the 24-bit address is set to 000000h, the Manufacturer ID is read out first followed by the Device ID. If the 24-bit address is set to 000001h, then the Device ID is read out first followed by the Manufacturer ID. The Manufacturer ID and Device ID are always shifted out on the SO output pin with the MSB first, as shown in Figure 10-14. Once the device is in Read-ID mode, the Manufacturer ID and Device ID output data toggle between address 000000H and 000001H until terminated by a low to high transition on the CS# input pin. The maximum clock frequency for the Read-ID (90h) command is at 104 MHz (FAST_READ). The Manufacturer ID and Device ID are output continuously until terminated by a low to high transition on CS# chip select input pin.

Figure 19. Read-ID (RDID) Command Timing Diagram

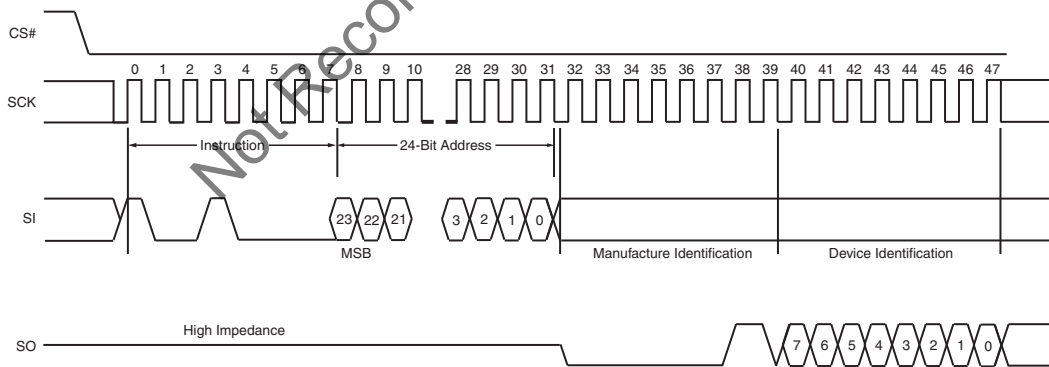

Table 16. READ_ID Data-Out Sequence

| | Address | Uniform |
|-----------------------------|---------|---------|
| Manufacturer Identification | 00000h | 01h |
| Device Identification | 00001h | 15h |

9.9 Write Enable (WREN)

The Write Enable (WREN) command (see Figure 20) sets the Write Enable Latch (WEL) bit to a 1, which enables the device to accept a Write Status Register, program, or erase command. The WEL bit must be set prior to every Page Program (PP), Quad Page Program (QPP), Parameter Sector Erase (P4E, P8E), Erase (SE or BE), Write Registers (WRR), and OTP Program (OTPP) command. The host system must first drive CS# low, write the WREN command, and then drive CS# high.

Figure 20. Write Enable (WREN) Command Sequence

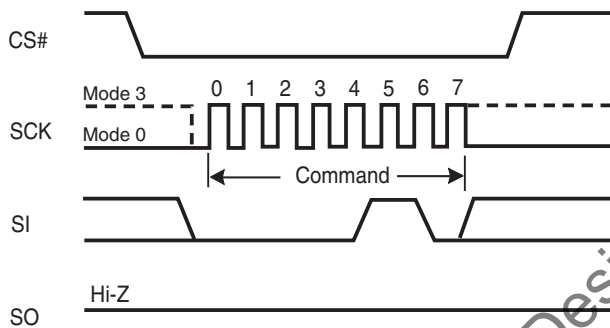

9.10 Write Disable (WRDI)

The Write Disable (WRDI) command (see Figure 21) resets the Write Enable Latch (WEL) bit to a 0, which disables the device from accepting a Page Program (PP), Quad Page Program (QPP), Parameter Sector Erase (P4E, P8E), Erase (SE, BE), Write Registers (WRR), and OTP Program (OTPP) command. The host system must first drive CS# low, write the WRDI command, and then drive CS# high.

Any of following conditions resets the WEL bit:

- Power-up
- Write Disable (WRDI) command completion
- Write Registers (WRR) command completion
- Page Program (PP) command completion
- Quad Page Program (QPP) completion
- Parameter Sector Erase (P4E, P8E) completion
- Sector Erase (SE) command completion
- Bulk Erase (BE) command completion
- OTP Program (OTPP) completion

Figure 21. Write Disable (WRDI) Command Sequence

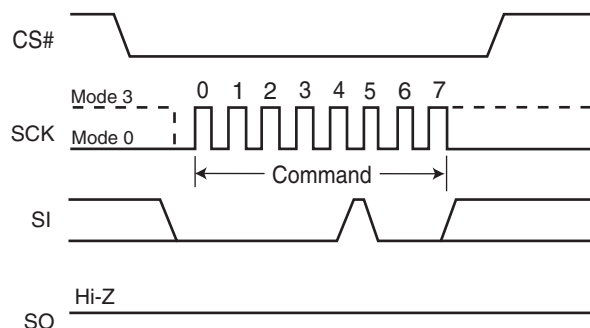

9.11 Read Status Register (RDSR)

The Read Status Register (RDSR) command outputs the state of the Status Register bits. Table 17 shows the status register bits and their functions. The RDSR command may be written at any time, even while a program, erase, or Write Registers operation is in progress. The host system should check the Write In Progress (WIP) bit before sending a new command to the device if an operation is already in progress. Figure 22 shows the RDSR command sequence, which also shows that it is possible to read the Status Register continuously until CS# is driven high. The maximum clock frequency for the RDSR command is 104 MHz.

Table 17. S25FL032P Status Register

| Bit | Status Register Bit | Bit Function | Description |
|-----|---------------------|-------------------------------|---|
| 7 | SRWD | Status Register Write Disable | 1 = Protects when W#/ACC is low 0 = No protection, even when W#/ACC is low |
| 6 | P_ERR | Programming Error Occurred | 0 = No Error 1 = Error occurred |
| 5 | E_ERR | Erase Error Occurred | 0 = No Error 1 = Error occurred |
| 4 | BP2 | Block Protect | Protects selected Block from Program or Erase |
| 3 | BP1 | | |
| 2 | BP0 | | |
| 1 | WEL | Write Enable Latch | 1 = Device accepts Write Registers, program or erase commands 0 = Ignores Write Registers, program or erase commands |
| 0 | WIP | Write in Progress | 1 = Device Busy a Write Registers, program or erase operation is in progress 0 = Ready. Device is in standby mode and can accept commands. |

Figure 22. Read Status Register (RDSR) Command Sequence

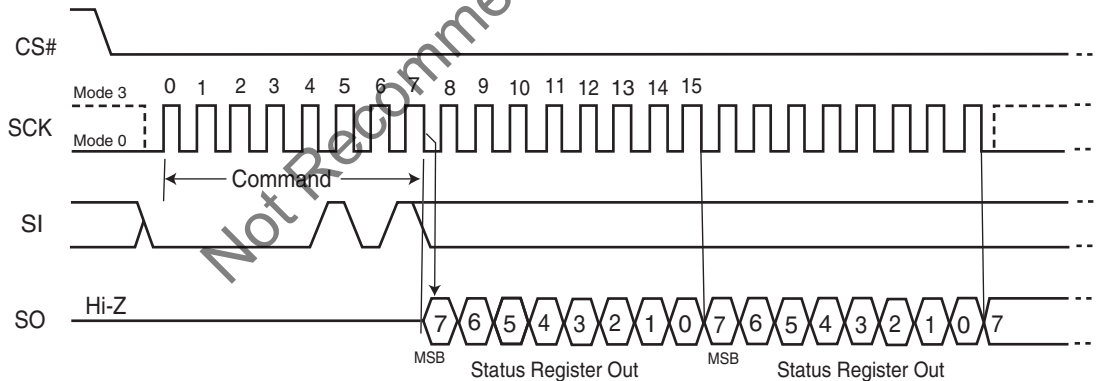

The following describes the status and control bits of the Status Register.

Write In Progress (WIP) bit: Indicates whether the device is busy performing a Write Registers, program, or erase operation. This bit is read-only, and is controlled internally by the device. If WIP is 1, one of these operations is in progress; if WIP is 0, no such operation is in progress. This bit is a Read-only bit.

Write Enable Latch (WEL) bit: Determines whether the device will accept and execute a Write Registers, program, or erase command. When set to 1, the device accepts these commands; when set to 0, the device rejects the commands. This bit is set to 1 by writing the WREN command, and set to 0 by the WRDI command, and is also automatically reset to 0 after the completion of a Write Registers, program, or erase operation, and after a power down/power up sequence. WEL cannot be directly set by the WRR command.

Block Protect (BP2, BP1, BP0) bits: Define the portion of the memory area that will be protected against any changes to the stored data. The Block Protection (BP2, BP1, BP0) bits are either volatile or non-volatile, depending on the state of the nonvolatile bit BPNV in the Configuration register. The Block Protection (BP2, BP1, BP0) bits are written with the Write Registers (WRR) instruction. When one or more of the Block Protect (BP2, BP1, BP0) bits is set to 1's, the relevant memory area is protected against Page Program (PP), Parameter Sector Erase (P4E, P8E), Sector Erase (SE), Quad Page Programming (QPP) and Bulk Erase (BE) instructions. If the Hardware Protected mode is enabled, BP2:BP0 cannot be changed.

The Bulk Erase (BE) instruction can be executed only when the Block Protection (BP2, BP1, BP0) bits are set to 0s. The default condition of the BP2-0 bits is binary 000 (all 0s).

Erase Error bit (E_ERR): The Erase Error Bit is used as a Erase operation success and failure check. When the Erase Error bit is set to a "1", it indicates that there was an error which occurred in the last erase operation. With the Erase Error bit set to a "1", this bit is reset with the Clear Status Register (CLSR) command.

Program Error bit (P_ERR): The Program Error Bit is used as a Program operation success and failure check. When the Program Error bit is set to a "1", it indicates that there was an error which occurred in the last program operation. With the Program Error bit set to a "1", this bit is reset with the Clear Status Register (CLSR) command.

Status Register Write Disable (SRWD) bit: Provides data protection when used together with the Write Protect (W#/ACC) signal. The Status Register Write Disable (SRWD) bit is operated in conjunction with the Write Protect (W#/ACC) input pin. The Status Register Write Disable (SRWD) bit and the Write Protect (W#/ACC) signal allow the device to be put in the Hardware Protected mode. With the Status Register Write Disable (SRWD) bit set to a "1" and the W#/ACC driven to the logic low state, the device enters the Hardware Protected mode; the non-volatile bits of the Status Register (SRWD, BP2, BP1, BP0) and the nonvolatile bits of the Configuration Register (TBPARM, TBPROT, BPNV and QUAD) become read-only bits and the Write Registers (WRR) instruction opcode is no longer accepted for execution.

Note: The P_ERR and E_ERR bits will not be set to a 1 if the application writes to a protected memory area.

9.12 Read Configuration Register (RCR)

The Read Configuration Register (RCR) instruction opcode allows the Configuration Register contents to be read out of the SO serial output pin. The Configuration Register contents may be read at any time, even while a program, erase, or write cycle is in progress. When one of these cycles is in progress, it is recommended to the user to check the Write In Progress (WIP) bit of the Status Register before issuing a new instruction opcode to the device. The Configuration Register originally shows 00h when the device is first shipped from the factory to the customer. Refer to [Section 7.8 on page 12](#) for more details.

Figure 23. Read Configuration Register (RCR) Instruction Sequence

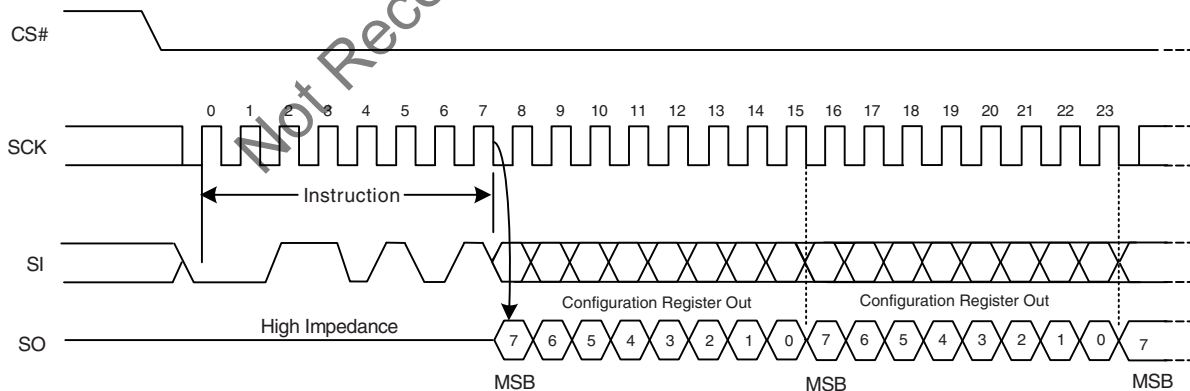

9.13 Write Registers (WRR)

The Write Registers (WRR) command allows changing the bits in the Status and Configuration Registers. A Write Enable (WREN) command, which itself sets the Write Enable Latch (WEL) in the Status Register, is required prior to writing the WRR command. Table 17 shows the status register bits and their functions.

The host system must drive CS# low, then write the WRR command and the appropriate data byte on SI Figure 24.

The WRR command cannot change the state of the Write Enable Latch (bit 1). The WREN command must be used for that purpose.

The Status Register consists of one data byte in length; similarly, the Configuration Register is also one data byte in length. The CS# pin must be driven to the logic low state during the entire duration of the sequence.

The WRR command also controls the value of the Status Register Write Disable (SRWD) bit. The SRWD bit and W#/ACC pin together place the device in the Hardware Protected Mode (HPM). The device ignores all WRR commands once it enters the Hardware Protected Mode (HPM). Table 18 shows that W#/ACC must be driven low and the SRWD bit must be 1 for this to occur.

The Write Registers (WRR) instruction has no effect on the P/E Error and the WIP bits of the Status & Configuration Registers. Any bit reserved for the future is always read as a '0'

The CS# chip select input pin must be driven to the logic high state after the eighth (see Figure 24) or sixteenth (see Figure 25) bit of data has been latched in. If not, the Write Registers (WRR) instruction is not executed. If CS# is driven high after the eighth cycle then only the Status Register is written to; otherwise, after the sixteenth cycle both the Status and Configuration Registers are written to. As soon as the CS# chip select input pin is driven to the logic high state, the self-timed Write Registers cycle is initiated. While the Write Registers cycle is in progress, the Status Register may still be read to check the value of the Write In Progress (WIP) bit. The Write In Progress (WIP) bit is a '1' during the self-timed Write Registers cycle, and is a '0' when it is completed. When the Write Registers cycle is completed, the Write Enable Latch (WEL) is set to a '0'. The WRR command can operate at a maximum clock frequency of 104 MHz.

Figure 24. Write Registers (WRR) Instruction Sequence – 8 data bits

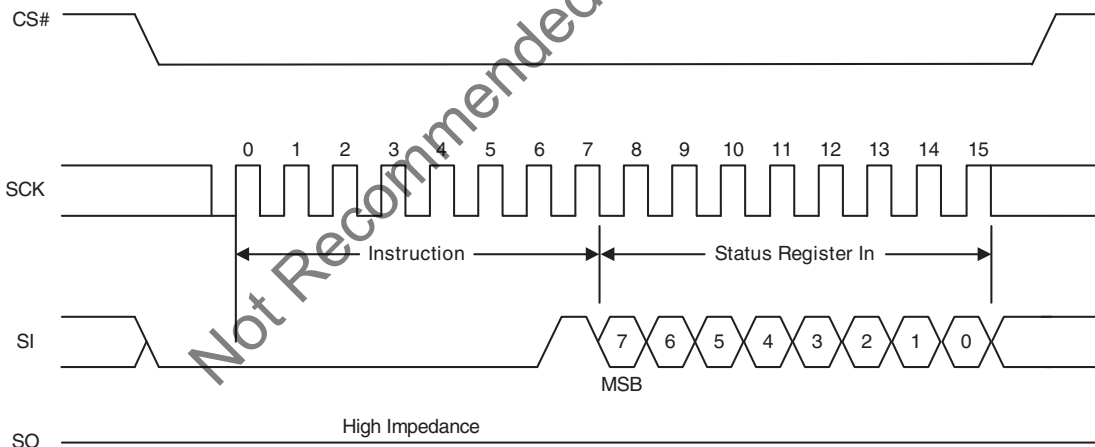

Figure 25. Write Registers (WRR) Instruction Sequence – 16 data bits

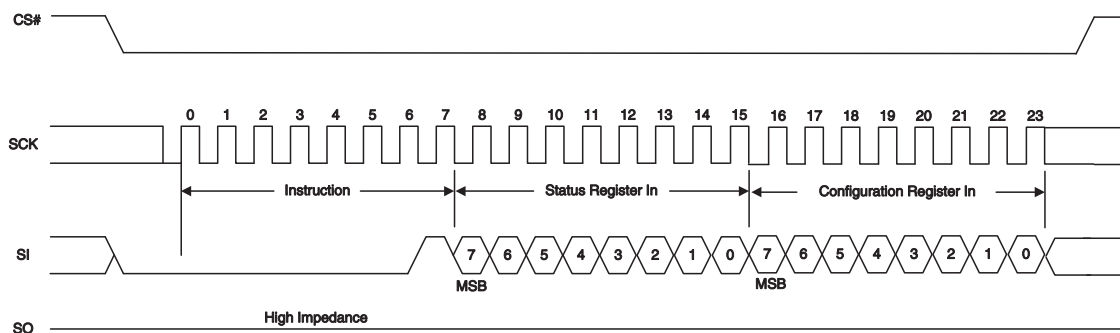

Table 18. Protection Modes

| W#/ACC | SRWD Bit | Mode | Write Protection of Registers | Memory Content | |
|--------|----------|--------------------------|--|--|---|
| | | | | Protected Area | Unprotected Area |
| 1 | 1 | Software Protected (SPM) | Status & Configuration Registers are Writable (if WREN instruction has set the WEL bit). The values in the SRWD, BP2, BP1, & BP0 bits & those in the Configuration Register can be changed | Protected against Page Program, Parameter Sector Erase, Sector Erase, and Bulk Erase | Ready to accept Page Program, Parameter Sector Erase, & Sector Erase instructions |
| 1 | 0 | | | | |
| 0 | 0 | | | | |
| 0 | 1 | Hardware Protected (HPM) | Status & Configuration Registers are Hardware Write Protected. The values in the SRWD, BP2, BP1, & BP0 bits & those in the Configuration Register cannot be changed | Protected against Page Program, Parameter Sector Erase, Sector Erase, and Bulk Erase | Ready to accept Page Program, Parameter Sector Erase, Sector Erase instructions |

Note

As defined by the values in the Block Protect (BP2, BP1, BP0) bits of the Status Register, as shown in [Table 6 on page 14](#).

[Table 18](#) shows that neither W#/ACC or SRWD bit by themselves can enable HPM. The device can enter HPM either by setting the SRWD bit after driving W#/ACC low, or by driving W#/ACC low after setting the SRWD bit. However, the device disables HPM only when W#/ACC is driven high.

Note that HPM only protects against changes to the status register. Since BP2:BP0 cannot be changed in HPM, the size of the protected area of the memory array cannot be changed. Note that HPM provides no protection to the memory array area outside that specified by BP2:BP0 (Software Protected Mode, or SPM).

If W#/ACC is permanently tied high, HPM can never be activated, and only the SPM (BP2:BP0 bits of the Status Register) can be used. The Status and Configuration registers originally default to 00h, when the device is first shipped from the factory to the customer.

Note: HPM is disabled when the Quad I/O Mode is enabled (Quad bit = 1 in the Configuration Register). W# becomes IO2; therefore, HPM cannot be utilized.

9.14 Page Program (PP)

The Page Program (PP) command changes specified bytes in the memory array (from 1 to 0 only). A WREN command is required prior to writing the PP command.

The host system must drive CS# low, and then write the PP command, three address bytes, and at least one data byte on SI. If the 8 least significant address bits (A7-A0) are not all zero, all transmitted data that goes beyond the end of the currently selected page are programmed from the starting address of the same page (from the address whose 8 least significant bits are all zero). CS# must be driven low for the entire duration of the PP sequence. The command sequence is shown in [Figure 26](#) and [Table 10 on page 18](#).

The device programs only the last 256 data bytes sent to the device. If the 8 least significant address bits (A7-A0) are not all zero, all transmitted data that goes beyond the end of the currently selected page are programmed from the starting address of the same page (from the address whose 8 least significant bits are all zero). If fewer than 256 data bytes are sent to device, they are correctly programmed at the requested addresses without having any effect on the other bytes in the same page.

The host system must drive CS# high after the device has latched the 8th bit of the data byte, otherwise the device does not execute the PP command. The PP operation begins as soon as CS# is driven high. The device internally controls the timing of the operation, which requires a period of t_{PP} . The Status Register may be read to check the value of the Write In Progress (WIP) bit while the PP operation is in progress. The WIP bit is 1 during the PP operation, and is 0 when the operation is completed. The device internally resets the Write Enable Latch to 0 before the operation completes (the exact timing is not specified).

The device does not execute a Page Program (PP) command that specifies a page that is protected by the Block Protect bits (BP2:BP0) (see [Table 6 on page 14](#)).

Figure 26. Page Program (PP) Command Sequence

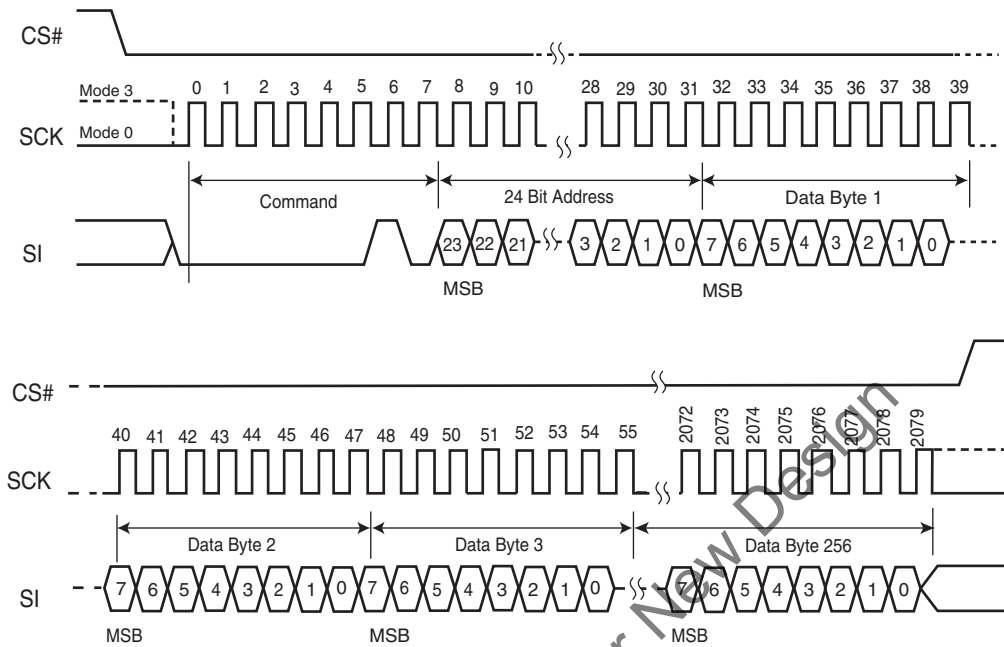

Not Recommended for New Design

9.15 QUAD Page Program (QPP)

The Quad Page Program instruction is similar to the Page Program instruction, except that the Quad Page Program (QPP) instruction allows up to 256 bytes of data to be programmed at previously erased (FFh) memory locations using four pins: IO0 (SI), IO1 (SO), IO2 (W#/ACC), and IO3 (HOLD#), instead of just one pin (SI) as in the case of the Page Program (PP) instruction. This effectively increases the data transfer rate by up to four times, as compared to the Page Program (PP) instruction. The QPP feature can improve performance for PROM Programmer and applications that have slow clock speeds < 5 MHz. Systems with faster clock speed will not realize much benefit for the QPP instruction since the inherent page program time is much greater than the time it take to clock-in the data.

To use QPP, the Quad Enable Bit in the Configuration Register must be set (QUAD = 1). A Write Enable instruction must be executed before the device will accept the Quad Page Program instruction (Status Register-1, WEL = 1). The instruction is initiated by driving the CS# pin low then shifting the instruction code "32h" followed by a 24 bit address (A23-A0) and at least one data byte, into the IO pins. The CS# pin must be held low for the entire length of the instruction while data is being sent to the device. All other functions of Quad Input Page Program are identical to standard Page Program. The QPP instruction sequence is shown below.

Figure 27. QUAD Page Program Instruction Sequence

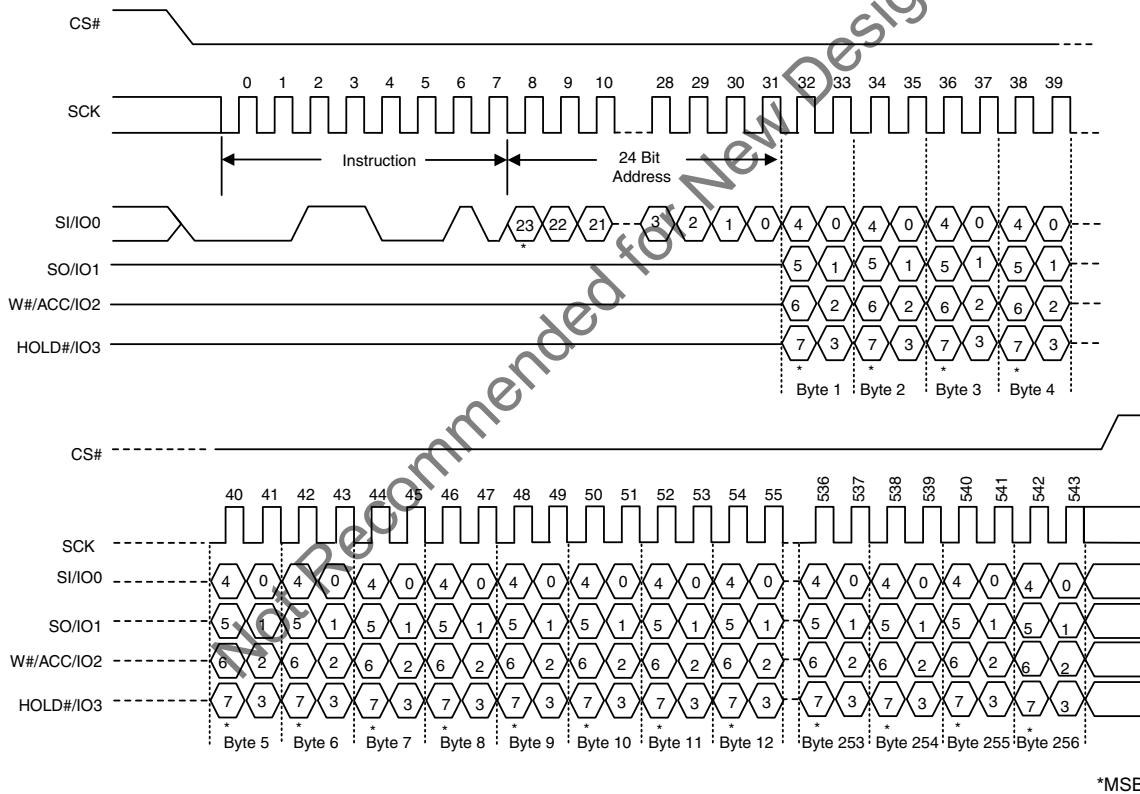

*MSB

9.16 Parameter Sector Erase (P4E, P8E)

The Parameter Sector Erase (P4E, P8E) command sets all bits at all addresses within a specified sector to a logic 1 (FFh). A WREN command is required prior to writing the Parameter Sector Erase commands.

The host system must drive CS# low, and then write the P4E or P8E command, plus three address bytes on SI. Any address within the sector (see Table 8 on page 16 and Table 9 on page 17) is a valid address for the P4E or P8E command. CS# must be driven low for the entire duration of the P4E/P8E sequence. The command sequence is shown in Figure 28 and Table 10 on page 18.

The host system must drive CS# high after the device has latched the 24th bit of the P4E/P8E address, otherwise the device does not execute the command. The parameter sector erase operation begins as soon as CS# is driven high. The device internally controls the timing of the operation, which requires a period of t_{SE} . The Status Register may be read to check the value of the Write In Progress (WIP) bit while the parameter sector erase operation is in progress. The WIP bit is 1 during the P4E/P8E operation, and is 0 when the operation is completed. The device internally resets the Write Enable Latch to 0 before the operation completes (the exact timing is not specified).

A Parameter Sector Erase (P4E, P8E) instruction applied to a sector that has been Write Protected through the Block Protect Bits will not be executed.

The Parameter Sector Erase Command (P8E) erases two of the 4 KB Sectors in selected address space. The Parameter Sector Erase Command (P8E) erases two sequential 4 KB Parameter Sectors in the selected address space. The address LSB is disregarded so that two sequential 4 KB Parameter Sectors are erased. The 24 Bit Address is any location within the first Sector to be erased (n), and the next sequential 4 KB Parameter Sector will also be erased (n+1). The 4 KB parameter Sector will only be erased properly if n or n+1 is a valid 4 KB parameter Sector; that is, if n is not a valid 4K parameter Sector, then it will not be erased. If n+1 is not a valid 4 KB parameter Sector, then it will not be erased.

Figure 28. Parameter Sector Erase (P4E, P8E) Instruction Sequence

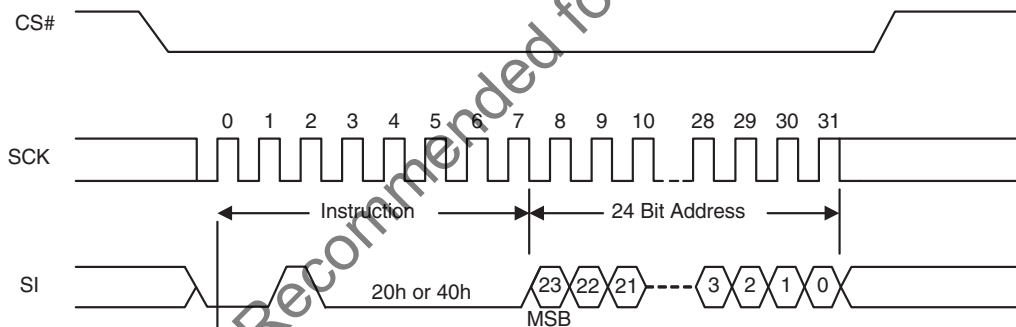

9.17 Sector Erase (SE)

The Sector Erase (SE) command sets all bits at all addresses within a specified sector to a logic 1. A WREN command is required prior to writing the SE command.

The host system must drive CS# low, and then write the SE command plus three address bytes on SI. Any address within the sector (see Table 6 on page 14) is a valid address for the SE command. CS# must be driven low for the entire duration of the SE sequence. The command sequence is shown in Figure 29 and Table 10 on page 18.

The host system must drive CS# high after the device has latched the 24th bit of the SE address, otherwise the device does not execute the command. The SE operation begins as soon as CS# is driven high. The device internally controls the timing of the operation, which requires a period of t_{SE} . The Status Register may be read to check the value of the Write In Progress (WIP) bit while the SE operation is in progress. The WIP bit is 1 during the SE operation, and is 0 when the operation is completed. The device internally resets the Write Enable Latch to 0 before the operation completes (the exact timing is not specified).

The device only executes a SE command if all Block Protect bits (BP2:BP0) are 0 (see Table 6 on page 14). Otherwise, the device ignores the command.

Figure 29. Sector Erase (SE) Command Sequence

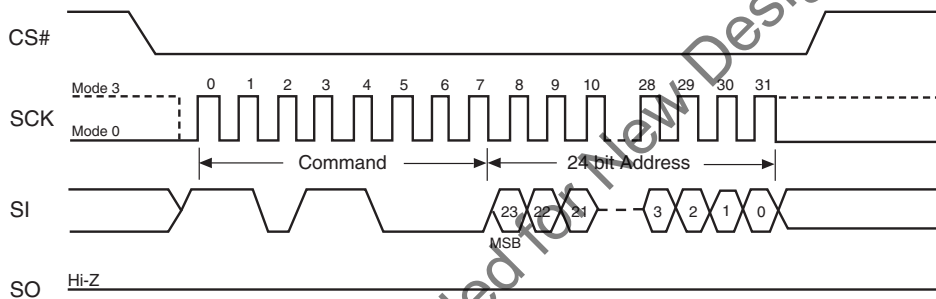

9.18 Bulk Erase (BE)

The Bulk Erase (BE) command sets all the bits within the entire memory array to logic 1s. A WREN command is required prior to writing the BE command.

The host system must drive CS# low, and then write the BE command on SI. CS# must be driven low for the entire duration of the BE sequence. The command sequence is shown in Figure 30 and Table 10 on page 18.

The host system must drive CS# high after the device has latched the 8th bit of the CE command, otherwise the device does not execute the command. The BE operation begins as soon as CS# is driven high. The device internally controls the timing of the operation, which requires a period of t_{BE} . The Status Register may be read to check the value of the Write In Progress (WIP) bit while the BE operation is in progress. The WIP bit is 1 during the BE operation, and is 0 when the operation is completed. The device internally resets the Write Enable Latch to 0 before the operation completes (the exact timing is not specified).

The device only executes a BE command if all Block Protect bits (BP2:BP0) are 0 (see Table 6 on page 14). Otherwise, the device ignores the command.

Figure 30. Bulk Erase (BE) Command Sequence

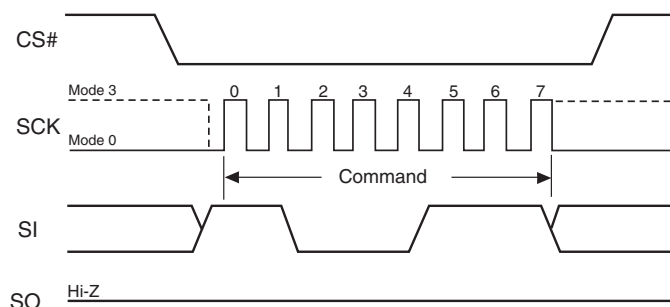

9.19 Deep Power-Down (DP)

The Deep Power-Down (DP) command provides the lowest power consumption mode of the device. It is intended for periods when the device is not in active use, and ignores all commands except for the Release from Deep Power-Down (RES) command. *The DP mode therefore provides the maximum data protection against unintended write operations.* The standard standby mode, which the device goes into automatically when CS# is high (and all operations in progress are complete), should generally be used for the lowest power consumption when the quickest return to device activity is required.

The host system must drive CS# low, and then write the DP command on SI. CS# must be driven low for the entire duration of the DP sequence. The command sequence is shown in Figure 31 and Table 10 on page 18.

The host system must drive CS# high after the device has latched the 8th bit of the DP command, otherwise the device does not execute the command. After a delay of t_{DP} , the device enters the DP mode and current reduces from I_{SB} to I_{DP} (see Table 23 on page 47).

Once the device has entered the DP mode, all commands are ignored except the RES command (which releases the device from the DP mode). The RES command also provides the Electronic Signature of the device to be output on SO, if desired (see Section 9.20 and Section 9.21).

DP mode automatically terminates when power is removed, and the device always powers up in the standard standby mode. The device rejects any DP command issued while it is executing a program, erase, or Write Registers operation, and continues the operation uninterrupted.

Figure 31. Deep Power-Down (DP) Command Sequence

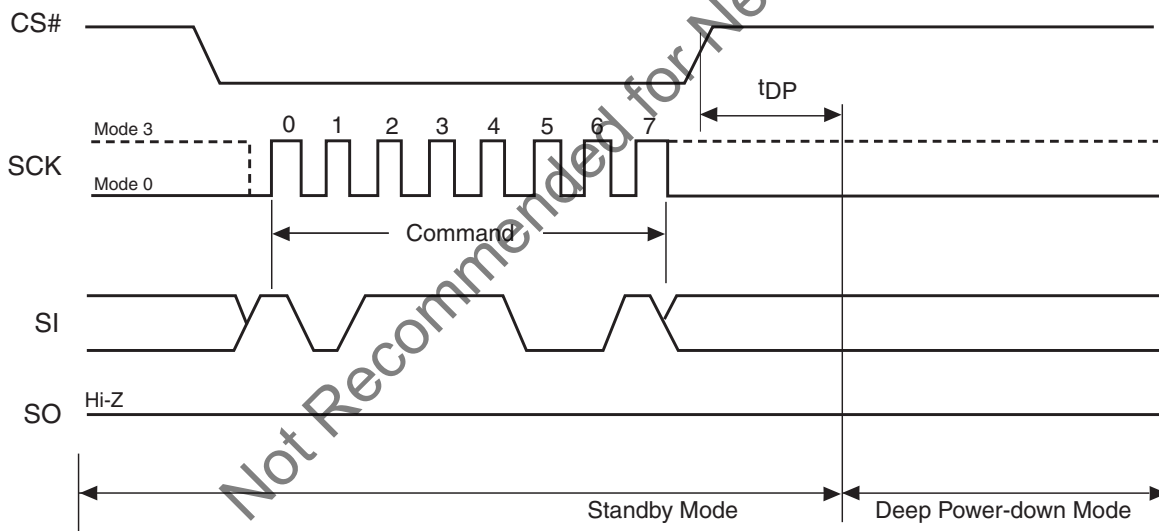

9.20 Release from Deep Power-Down (RES)

The device requires the Release from Deep Power-Down (RES) command to exit the Deep Power-Down mode. When the device is in the Deep Power-Down mode, all commands except RES are ignored.

The host system must drive CS# low and write the RES command to SI. CS# must be driven low for the entire duration of the sequence. The command sequence is shown in Figure 32 and Table 10 on page 18.

The host system must drive CS# high $t_{RES(max)}$ after the 8-bit RES command byte. The device transitions from DP mode to the standby mode after a delay of t_{RES} (see Figure 25). In the standby mode, the device can execute any read or write command.

Note: The RES command does not reset the Write Enable Latch (WEL) bit.

Figure 32. Release from Deep Power-Down (RES) Command Sequence

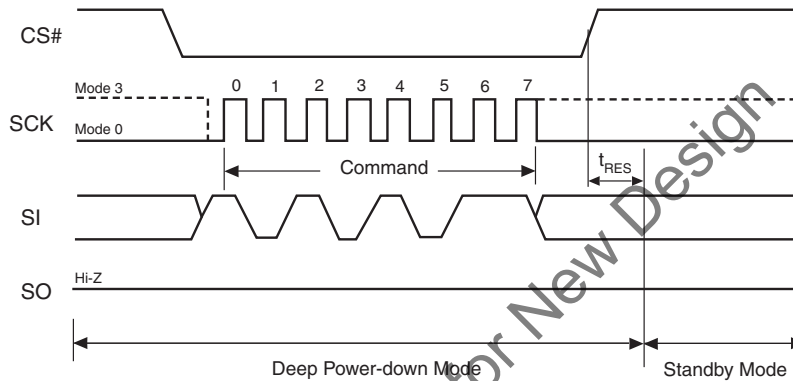

9.20.1 Release from Deep Power-Down and Read Electronic Signature (RES)

The device features an 8-bit Electronic Signature, which can be read using the RES command. See Figure 33 and Table 10 on page 18 for the command sequence and signature value. The Electronic Signature is not to be confused with the identification data obtained using the RDID command. The device offers the Electronic Signature so that it can be used with previous devices that offered it; however, the Electronic Signature should not be used for new designs, which should read the RDID data instead.

After the host system drives CS# low, it must write the RES command followed by 3 dummy bytes to SI (each bit is latched on SI during the rising edge of SCK). The Electronic Signature is then output on SO; each bit is shifted out on the falling edge of SCK. The RES operation is terminated by driving CS# high after the Electronic Signature is read at least once. Additional clock cycles on SCK with CS# low cause the device to output the Electronic Signature repeatedly.

When CS# is driven high, the device transitions from DP mode to the standby mode after a delay of t_{RES} , as previously described. The RES command always provides access to the Electronic Signature of the device and can be applied even if DP mode has not been entered. Any RES command issued while an erase, program, or Write Registers operation is in progress not executed, and the operation continues uninterrupted.

Figure 33. Release from Deep Power-Down and RES Command Sequence

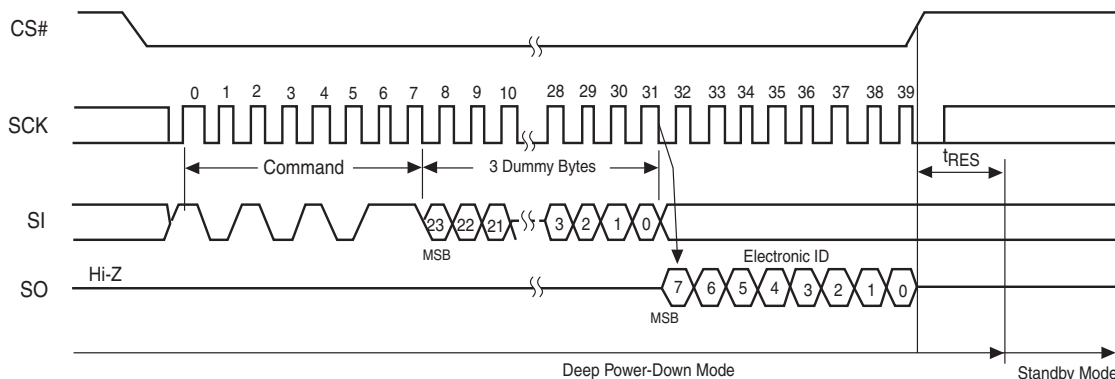

9.21 Clear Status Register (CLSR)

The Clear Status Register command resets bit SR5 (Erase Fail Flag) and bit SR6 (Program Fail Flag). It is not necessary to set the WEL bit before the Clear SR Fail Flags command is executed. The WEL bit will be unchanged after this command is executed. This command also resets the State machine and loads latches

Figure 34. Clear Status Register (CLSR) Instruction Sequence

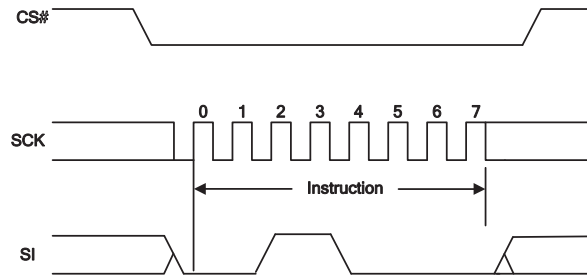

9.22 OTP Program (OTPP)

The OTP Program command programs data in the OTP region, which is in a different address space from the main array data. Refer to, [Section 10., OTP Regions on page 41](#) for details on the OTP region. The protocol of the OTP Program command is the same as the Page Program command, except that the OTP Program command requires exactly one byte of data; otherwise, the command will be ignored. To program the OTP in bit granularity, the rest of the bits within the data byte can be set to “1”.

The OTP memory space can be programmed one or more times, provided that the OTP memory space is not locked (as described in “Locking OTP Regions”). Subsequent OTP programming can be performed only on the unprogrammed bits (that is, “1” data).

Note: The Write Enable (WREN) command must precede the OTP command before programming of the OTP can occur.

Figure 35. OTP Program Instruction Sequence

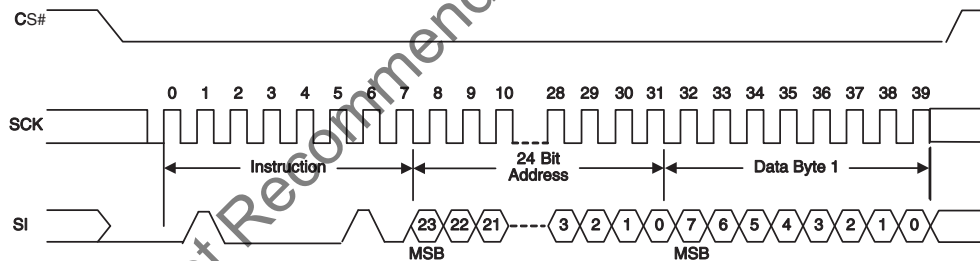

9.23 Read OTP Data Bytes (OTPR)

The Read OTP Data Bytes command reads data from the OTP region. Refer to [Section 10.](#) for details on the OTP region. The protocol of the Read OTP Data Bytes command is the same as the Fast Read Data Bytes command except that it will not wrap to the starting address after the OTP address is at its maximum; instead, the data will be indeterminate.

Figure 36. Read OTP Instruction Sequence

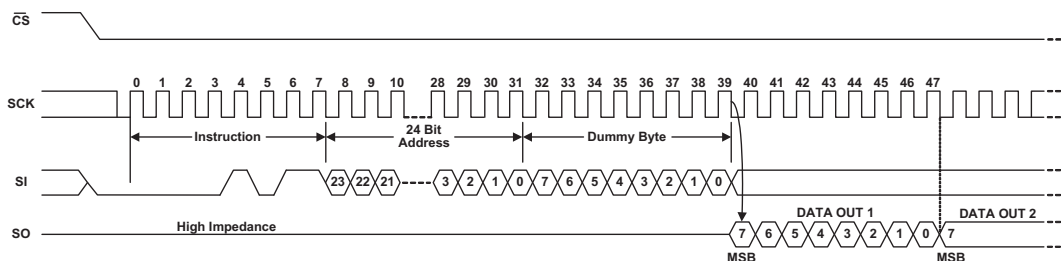

10. OTP Regions

The OTP Regions are separately addressable from the main array and consists of two 8-byte (ESN), thirty 16-byte, and one 10-byte regions that can be individually locked.

- The two 8-byte ESN region is a special order part (please contact your local Cypress sales representative for further details). The two 8-byte regions enable permanent part identification through an Electronic Serial Number (ESN). The customer can utilize the ESN to pair a Flash device with the system CPU/ASIC to prevent system cloning. The Cypress factory programs and locks the lower 8-byte ESN with a 64-bit randomly generated, unique number. The upper 8-byte ESN is left blank for customer use or, if special ordered, Cypress can program (and lock) in a unique customer ID.

Table 19. ESN1 and ESN2

| | Lock register ESN1 (Bit 0) | Lock register ESN2 (Bit 1) | ESN1 region contains | ESN2 region contains |
|--------------------|----------------------------|----------------------------|-----------------------|-------------------------------------|
| Standard part | 1h | 1h | 0h | 0h |
| Special order part | 1h | 1h/0h | Unique random pattern | Factory/Customer programmed pattern |

- The thirty 16-byte and one 10-byte OTP regions are open for the customer usage.
- The thirty 16-byte, one 10-byte, and upper 8-byte ESN OTP regions can be individually locked by the end user. Once locked, the data cannot be changed. The locking process is permanent and cannot be undone.

The following general conditions should be noted with respect to the OTP Regions.

- On power-up, or following a hardware reset, or at the end of an OTPP or an OTPR command, the device reverts to sending commands to the normal address space.
- Reads or Programs outside of the OTP Regions will be ignored
- The OTP Region is not accessible when the device is executing an Embedded Program or Embedded Erase algorithm.
- The ACC function is not available when accessing the OTP Regions.
- The thirty 16-byte and one 10-byte OTP regions are left open for customer usage, but special care of the OTP locking must be maintained, or else a malevolent user can permanently lock the OTP regions. This is not a concern, if the OTP regions are not used.

10.1 Programming OTP Address Space

The protocol of the OTP Program command (42h) is the same as the Page Program command. Refer to [Table 10](#) for the command description and protocol. The OTP Program command can be issued multiple times to any given OTP address, but this address space can never be erased. After a given OTP region is programmed, it can be locked to prevent further programming with the OTP lock registers (refer to [Section 10.3](#)). The valid address range for OTP Program is depicted in the figure below. OTP Program operations outside the valid OTP address range will be ignored.

10.2 Reading OTP Data

The protocol of the OTP Read command (4Bh) is the same as that of the Fast Read command. Refer to [Table 10](#) for the command description and protocol. The valid address range for OTP Reads is depicted in the figure below. OTP Read operations outside the valid OTP address range will yield indeterminate data.

10.3 Locking OTP Regions

In order to permanently lock the ESN and OTP regions, individual bits at the specified addresses can be set to lock specific regions of OTP memory, as highlighted in [Figure 37](#) and [Figure 38](#).

Figure 37. OTP Memory Map - Part 1

| ADDRESS | OTP REGION |
|--------------------------------------|-------------------------|
| 0x213h ⋮ 0x204h 0x203h | 16 bytes (OTP16) |
| 0x1F4h 0x1F3h | 16 bytes (OTP15) |
| 0x1E4h 0x1E3 | 16 bytes (OTP14) |
| 0x1D4h 0x1D3h | 16 bytes (OTP13) |
| 0x1C4h 0x1C3h | 16 bytes (OTP12) |
| 0x1B4h 0x1B3h | 16 bytes (OTP11) |
| 0x1A4h 0x1A3h | 16 bytes (OTP10) |
| 0x194h 0x193h | 16 bytes (OTP9) |
| 0x184h 0x183h | 16 bytes (OTP8) |
| 0x174h 0x173h | 16 bytes (OTP7) |
| 0x164h 0x163h | 16 bytes (OTP6) |
| 0x154h 0x153h | 16 bytes (OTP5) |
| 0x144h 0x143h | 16 bytes (OTP4) |
| 0x134h 0x133h | 16 bytes (OTP3) |
| 0x124h 0x123h | 16 bytes (OTP2) |
| 0x114h 0x113h 0x112h 0x111h | 16 bytes (OTP1) |
| 0x10Ah 0x109h | 8 bytes (ESN2) |
| 0x102h 0x101h 0x100h | 8 bytes (ESN1) |
| | Reserved |
| | X X X X X X Bit 1 Bit 0 |

| Address | Bit | Locks Region... |
|---------|-------|-----------------|
| 0x112h | 0 | OTP1 |
| | 1 | OTP2 |
| | 2 | OTP3 |
| | 3 | OTP4 |
| | 4 | OTP5 |
| | 5 | OTP6 |
| | 6 | OTP7 |
| | 7 | OTP8 |
| 0x113h | 0 | OTP9 |
| | 1 | OTP10 |
| | 2 | OTP11 |
| | 3 | OTP12 |
| | 4 | OTP13 |
| | 5 | OTP14 |
| | 6 | OTP15 |
| | 7 | OTP16 |
| 0x100h | 0 | ESN1 |
| | 1 | ESN2 |
| | 2 - 7 | Reserved |

Notes

1. Bit 0 at address 0x100h locks ESN1 region.
2. Bit 1 at address 0x100h locks ESN2 region.
3. Bits 2-7 ("X") are NOT programmable and will be ignored.

Figure 38. OTP Memory Map - Part 2

| ADDRESS | OTP REGION |
|---------------------------------|------------------|
| 0x2FFh ⋮ 0x2F6h 0x2F5h | 10 bytes (OTP31) |
| 0x2E6h 0x2E5 | 16 bytes (OTP30) |
| 0x2D6h 0x2D5h | 16 bytes (OTP29) |
| 0x2C6h 0x2C5h | 16 bytes (OTP28) |
| 0x2B6h 0x2B5h | 16 bytes (OTP27) |
| 0x2A6h 0x2A5h | 16 bytes (OTP26) |
| 0x296h 0x295h | 16 bytes (OTP25) |
| 0x286h 0x285h | 16 bytes (OTP24) |
| 0x276h 0x275h | 16 bytes (OTP23) |
| 0x266h 0x265h | 16 bytes (OTP22) |
| 0x256h 0x255h | 16 bytes (OTP21) |
| 0x246h 0x245h | 16 bytes (OTP20) |
| 0x236h 0x235h | 16 bytes (OTP19) |
| 0x226h 0x225h | 16 bytes (OTP18) |
| 0x216h 0x215h 0x214h | 16 bytes (OTP17) |

| Address | Bit | Locks Region... |
|---------|-------|-----------------|
| 0x214h | 0 | OTP17 |
| | 1 | OTP18 |
| | 2 | OTP19 |
| | 3 | OTP20 |
| | 4 | OTP21 |
| | 5 | OTP22 |
| | 6 | OTP23 |
| 0x215h | 7 | OTP24 |
| | 0 | OTP25 |
| | 1 | OTP26 |
| | 2 | OTP27 |
| | 3 | OTP28 |
| | 4 | OTP29 |
| | 5 | OTP30 |
| 6 | OTP31 | |
| | 7 | Reserved |

Note
 1. Bit 7 ("X") at address 0x215h is NOT programmable and will be ignored.

11. Power-up and Power-down

During power-up and power-down, certain conditions must be observed. CS# must follow the voltage applied on V_{CC}, and must not be driven low to select the device until V_{CC} reaches the allowable values as follows (see Figure 39 and Table 20 on page 45):

- At power-up, V_{CC} (min.) plus a period of t_{PU}
- At power-down, GND

A pull-up resistor on Chip Select (CS#) typically meets proper power-up and power-down requirements.

No Read, Write Registers, program, or erase command should be sent to the device until V_{CC} rises to the V_{CC} min., plus a delay of t_{PU}. At power-up, the device is in standby mode (not Deep Power-Down mode) and the WEL bit is reset (0).

Each device in the host system should have the V_{CC} rail decoupled by a suitable capacitor close to the package pins (this capacitor is generally of the order of 0.1 μF), as a precaution to stabilizing the V_{CC} feed.

When V_{CC} drops from the operating voltage to below the minimum V_{CC} threshold at power-down, all operations are disabled and the device does not respond to any commands. Note that data corruption may result if a power-down occurs while a Write Registers, program, or erase operation is in progress.

Figure 39. Power-Up Timing Diagram

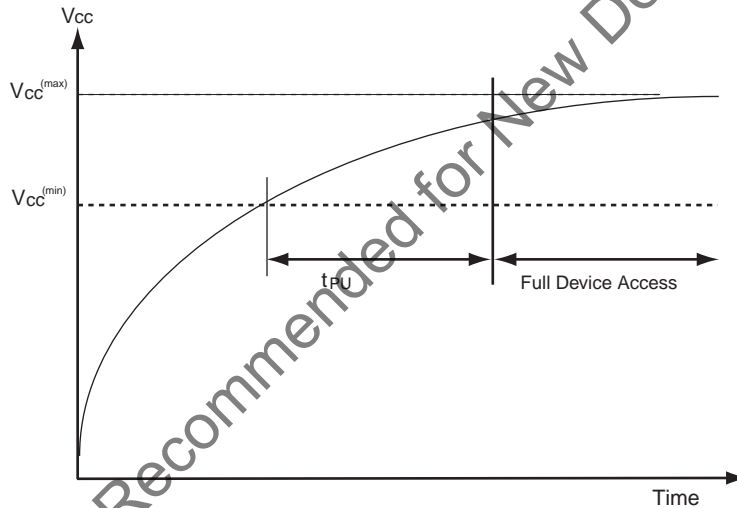

Figure 40. Power-Down and Voltage Drop

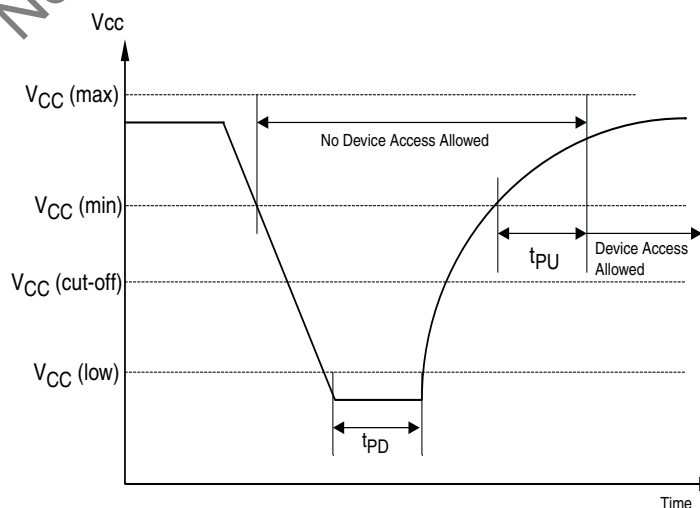

Table 20. Power-Up / Power-Down Voltage and Timing

| Symbol | Parameter | Min | Max | Unit |
|-------------------|--|------------|-----|---------|
| $V_{CC(min)}$ | V_{CC} (minimum operation voltage) | 2.7 | | V |
| $V_{CC(cut-off)}$ | V_{CC} (Cut off where re-initialization is needed) | 2.4 | | V |
| $V_{CC(low)}$ | V_{CC} (Low voltage for initialization to occur at read/standby) V_{CC} (Low voltage for initialization to occur at embedded) | 0.2 2.3 | | V |
| t_{PU} | $V_{CC(min.)}$ to device operation | | 300 | μs |
| t_{PD} | V_{CC} (low duration time) | 1.0 | | μs |

12. Initial Delivery State

The device is delivered with the memory array erased, that is, all bits are set to 1 (FFh) upon initial factory shipment. The Status Register and Configuration Register contains 00h (all bits are set to 0).

13. Program Acceleration via W#/ACC Pin

The program acceleration function requires applying V_{HH} to the W#/ACC input, and then waiting a period of t_{WC} . Minimum t_{VHH} rise and fall times is required for W#/ACC to change to V_{HH} from V_{IL} or V_{IH} . Removing V_{HH} from the W#/ACC pin returns the device to normal operation after a period of t_{WC} .

Figure 41. ACC Program Acceleration Timing Requirements



Note

Only Read Status Register (RDSR) and Page Program (PP) operation are allow when ACC is at (V_{HH}).
The W#/ACC pin is disabled during Quad I/O mode.

Table 21. ACC Program Acceleration Specifications

| Symbol | Parameter | Min. | Max | Unit |
|-----------|---|------|-----|---------|
| V_{HH} | ACC Pin Voltage High | 8.5 | 9.5 | V |
| t_{VHH} | ACC Voltage Rise and Fall time | 2.2 | | μs |
| t_{WC} | ACC at V_{HH} and V_{IL} or V_{IH} to First command | 5 | | μs |

14. Electrical Specifications

14.1 Absolute Maximum Ratings

| Description | Rating |
|---|--------------------------|
| Ambient Storage Temperature | -65 °C to +150 °C |
| Voltage with Respect to Ground: All Inputs and I/Os | -0.5 V to $V_{CC}+0.5$ V |
| Output Short Circuit Current (Note 2) | 200 mA |

Notes

- Minimum DC voltage on input or I/Os is -0.5 V. During voltage transitions, inputs or I/Os may undershoot GND to -2.0 V for periods of up to 20 ns. See Figure 42.
Maximum DC voltage on input or I/Os is $V_{CC} + 0.5$ V. During voltage transitions inputs or I/Os may overshoot to $V_{CC} + 2.0$ V for periods up to 20 ns. See Figure 43.
- No more than one output may be shorted to ground at a time. Duration of the short circuit should not be greater than one second.
- Stresses above those listed under "Absolute Maximum Ratings" may cause permanent damage to the device. This is a stress rating only; functional operation of the device at these or any other conditions above those indicated in the operational sections of this data sheet is not implied. Exposure of the device to absolute maximum rating conditions for extended periods may affect device reliability.

Figure 42. Maximum Negative Overshoot Waveform

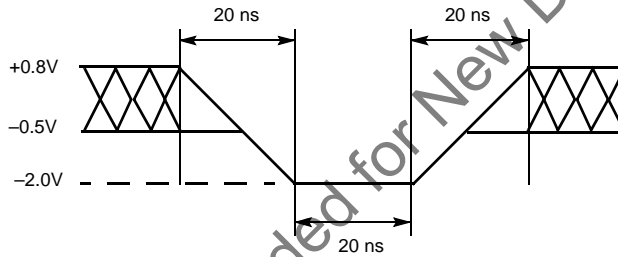
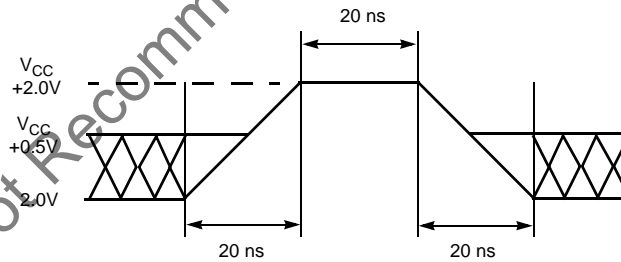

Figure 43. Maximum Positive Overshoot Waveform



15. Operating Ranges

Table 22. Operating Ranges

| Description | | Rating |
|---|---------------------|-------------------|
| Ambient Operating Temperature (T_A) | Industrial | -40 °C to +85 °C |
| | Automotive In-Cabin | -40 °C to +105 °C |
| Positive Power Supply | Voltage Range | 2.7 V to 3.6 V |

Note

Operating ranges define those limits between which functionality of the device is guaranteed.

16. DC Characteristics

This section summarizes the DC Characteristics of the device. Designers should check that the operating conditions in their circuit match the measurement conditions specified in Table 24 on page 48, when relying on the quoted parameters.

Table 23. DC Characteristics (CMOS Compatible)

| Symbol | Parameter | Test Conditions | Limits | | | Unit |
|-----------|--|---|---------------------|------|---------------------|---------------|
| | | | Min. | Typ* | Max | |
| V_{CC} | Supply voltage | | 2.7 | | 3.6 | V |
| V_{HH} | ACC Program Acceleration Voltage | $V_{CC} = 2.7 \text{ V to } 3.6 \text{ V}$ | 8.5 | | 9.5 | V |
| V_{IL} | Input Low Voltage** | | -0.3 | | $0.3 \times V_{CC}$ | V |
| V_{IH} | Input High Voltage** | | $0.7 \times V_{CC}$ | | $V_{CC} + 0.5$ | V |
| V_{OL} | Output Low Voltage | $I_{OL} = 1.6 \text{ mA}, V_{CC} = V_{CC \text{ min.}}$ | | | 0.4 | V |
| V_{OH} | Output High Voltage | $I_{OH} = -0.1 \text{ mA}$ | $V_{CC} - 0.6$ | | | V |
| I_{LI} | Input Leakage Current | $V_{CC} = V_{CC \text{ Max}}, V_{IN} = V_{CC} \text{ or GND}$ | | | ± 2 | μA |
| I_{LO} | Output Leakage Current | $V_{CC} = V_{CC \text{ Max}}, V_{IN} = V_{CC} \text{ or GND}$ | | | ± 2 | μA |
| I_{CC1} | Active Power Supply Current - READ (SO = Open) | At 80 MHz (Dual or Quad) | | | 38 | mA |
| | | At 104 MHz (Serial) | | | 25 | |
| | | At 40 MHz (Serial) | | | 12 | |
| I_{CC2} | Active Power Supply Current (Page Program) | $CS\# = V_{CC}$ | | | 26 | mA |
| I_{CC3} | Active Power Supply Current (WRR) | $CS\# = V_{CC}$ | | | 15 | mA |
| I_{CC4} | Active Power Supply Current (SE) | $CS\# = V_{CC}$ | | | 26 | mA |
| I_{CC5} | Active Power Supply Current (BE) | $CS\# = V_{CC}$ | | | 26 | mA |
| I_{SB1} | Standby Current | $CS\# = V_{CC}; SO + V_{IN} = \text{GND or } V_{CC}$ | | 80 | 200 | μA |
| I_{PD} | Deep Power-down Current | $CS\# = V_{CC}; SO + V_{IN} = \text{GND or } V_{CC}$ | | 3 | 10 | μA |

*Typical values are at $T_{AI} = 25 \text{ }^\circ\text{C}$ and $V_{CC} = 3 \text{ V}$

17. Test Conditions

Figure 44. AC Measurements I/O Waveform

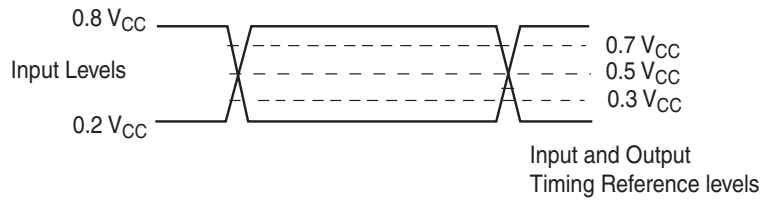

Table 24. Test Specifications

| Symbol | Parameter | Min | Max | Unit |
|--------|---------------------------------|------------------------------|-----|------|
| C_L | Load Capacitance | | 30 | pF |
| | Input Rise and Fall Times | | 5 | ns |
| | Input Pulse Voltage | $0.2 V_{CC}$ to $0.8 V_{CC}$ | | V |
| | Input Timing Reference Voltage | $0.3 V_{CC}$ to $0.7 V_{CC}$ | | V |
| | Output Timing Reference Voltage | $0.5 V_{CC}$ | | V |

Not Recommended for New Design

18. AC Characteristics

Table 25. AC Characteristics

| Symbol (Notes) | Parameter (Notes) | Min. (Notes) | Typ (Notes) | Max (Notes) | Unit |
|---------------------|---|--------------|-------------|--------------------------------|------|
| f_R | SCK Clock Frequency for READ command | DC | | 40 | MHz |
| | SCK Clock Frequency for RDID command | DC | | 50 | |
| f_C | SCK Clock Frequency for all others: FAST_READ, PP, QPP, P4E, P8E, SE, BE, DP, RES, WREN, WRDI, RDSR, WRR, READ_ID | DC | | 104 (serial) 80 (dual/quad) | MHz |
| t_{WH}, t_{CH} | Clock High Time (5) | 4.5 | | | ns |
| t_{WL}, t_{CL} | Clock Low Time (5) | 4.5 | | | ns |
| t_{CRT}, t_{CLCH} | Clock Rise Time (slew rate) | 0.1 | | | V/ns |
| t_{CFT}, t_{CHCL} | Clock Fall Time (slew rate) | 0.1 | | | V/ns |
| t_{CS} | CS# High Time (Read Instructions) | 10 | | | ns |
| | CS# High Time (Program/Erase) | 50 | | | |
| t_{CSS} | CS# Active Setup Time (relative to SCK) | 3 | | | ns |
| t_{CSH} | CS# Active Hold Time (relative to SCK) | 3 | | | ns |
| $t_{SU:DAT}$ | Data in Setup Time | 3 | | | ns |
| $t_{HD:DAT}$ | Data in Hold Time | 2 | | | ns |
| t_V | Clock Low to Output Valid | 0 | | 8 (Serial) ^Δ | ns |
| | | | | 9.5 (Dual/Quad) ^Δ | |
| | | | | 6.5 (Serial) [∞] | |
| | | | | 8 (Dual/Quad) [∞] | |
| | | | | 7 (Dual/Quad) ^Ω | |
| t_{HO} | Output Hold Time | 2 | | | ns |
| t_{DIS} | Output Disable Time | | | 8 | ns |
| t_{HLCH} | HOLD# Active Setup Time (relative to SCK) | 3 | | | ns |
| t_{CHHH} | HOLD# Active Hold Time (relative to SCK) | 3 | | | ns |
| t_{HHCH} | HOLD# Non Active Setup Time (relative to SCK) | 3 | | | ns |
| t_{CHHL} | HOLD# Non Active Hold Time (relative to SCK) | 3 | | | ns |
| t_{HZ} | HOLD# enable to Output Invalid | | | 8 | ns |
| t_{LZ} | HOLD# disable to Output Valid | | | 8 | ns |
| t_{WPS} | W#/ACC Setup Time (4) | 20 | | | ns |
| t_{WPH} | W#/ACC Hold Time (4) | 100 | | | ns |
| t_W | WRR Cycle Time | | | 50 | ms |
| t_{PP} | Page Programming (1)(2) | | 1.5 | 3 | ms |
| t_{EP} | Page Programming (ACC = 9 V) (1)(2)(3) | | 1.2 | 2.4 | ms |

Table 25. AC Characteristics (Continued)

| Symbol (Notes) | Parameter (Notes) | Min. (Notes) | Typ (Notes) | Max (Notes) | Unit |
|------------------|--|--------------|-------------|-------------|------|
| t _{SE} | Sector Erase Time (64 KB) (1)(2) | | 0.5 | 2 | sec |
| t _{PE} | Parameter Sector Erase Time (1)(2) (4 KB or 8 KB) | | 200 | 800 | ms |
| t _{BE} | Bulk Erase Time (1)(2) | | 32 | 64 | sec |
| t _{RES} | Deep Power-down to Standby Mode | | | 30 | μs |
| t _{DP} | Time to enter Deep Power-down Mode | | | 10 | μs |
| t _{VHH} | ACC Voltage Rise and Fall time | 2.2 | | | μs |
| t _{WC} | ACC at VHH and VIL or VIH to first command | 5 | | | μs |

Notes

1. Typical program and erase times assume the following conditions: 25°C, V_{CC} = 3.0 V; 10,000 cycles; checkerboard data pattern.
2. Under worst-case conditions of 85°C; V_{CC} = 2.7 V; 100,000 cycles.
3. Acceleration mode (9 V ACC) only in Program mode, not Erase.
4. Only applicable as a constraint for WRR instruction when SRWD is set to a '1'.
5. t_{WH} + t_{WL} must be less than or equal to 1/f_C.
6. Δ Full Vcc range (2.7 – 3.6 V) & CL = 30 pF.
7. ∞ Regulated Vcc range (3.0 – 3.6 V) & CL = 30 pF.
8. Ω Regulated Vcc range (3.0 – 3.6 V) & CL = 15 pF.

18.1 Capacitance

| Symbol | Parameter | Test Conditions | Min | Typ | Max | Unit |
|------------------|---|------------------------|-----|------|------|------|
| C _{IN} | Input Capacitance (applies to SCK, PO7-PO0, SI, CS#) | V _{OUT} = 0 V | | 9.0 | 12.0 | pF |
| C _{OUT} | Output Capacitance (applies to PO7-PO0, SO) | V _{IN} = 0 V | | 12.0 | 16.0 | pF |

Notes

1. Sampled, not 100% tested.
2. Test conditions T_A = 25°C, f = 1.0 MHz.
3. For more information on pin capacitance, please consult the IBIS models.

Figure 45. SPI Mode 0 (0,0) Input Timing

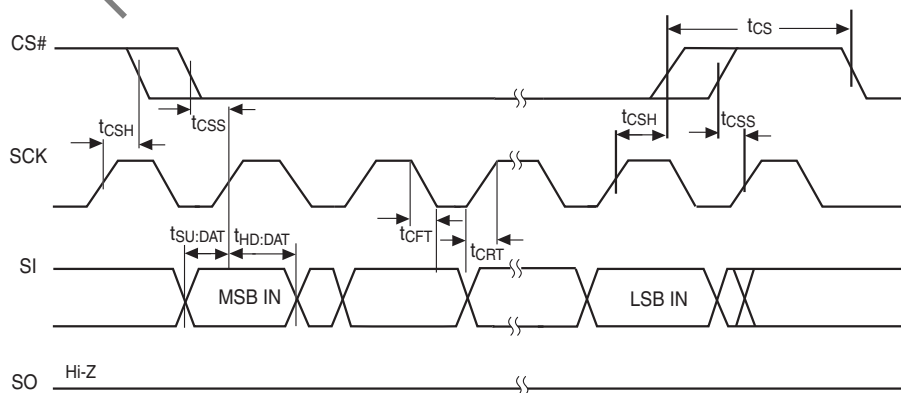

Figure 46. SPI Mode 0 (0,0) Output Timing

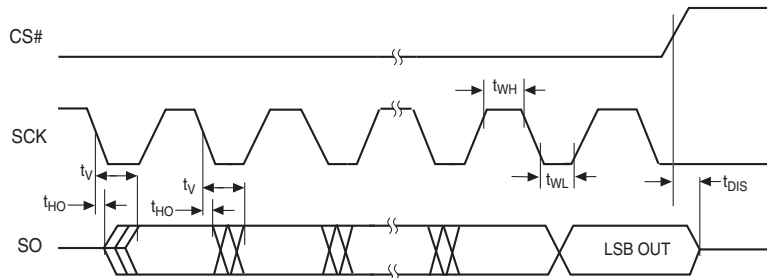

Figure 47. HOLD# Timing

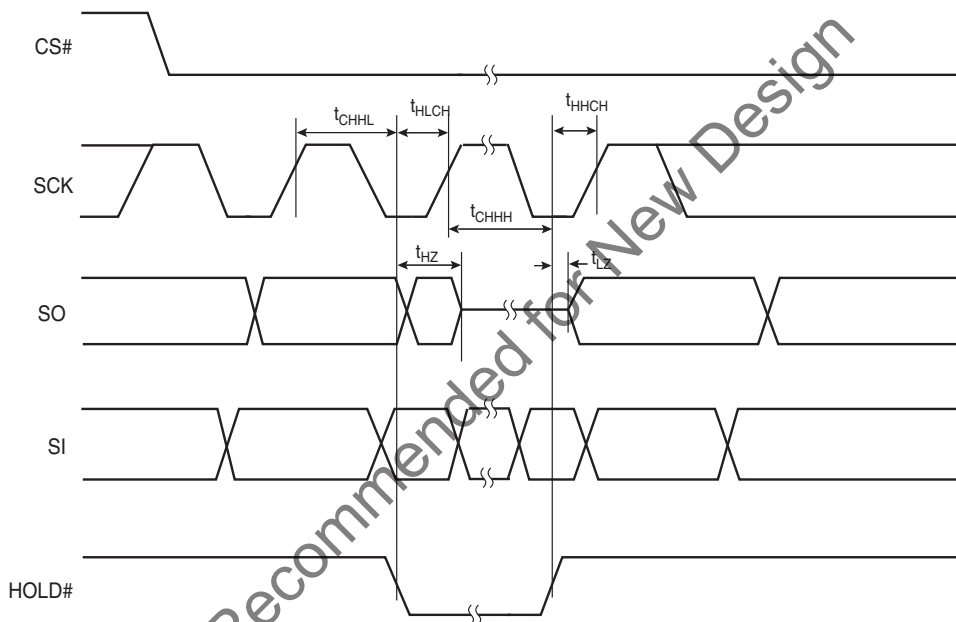
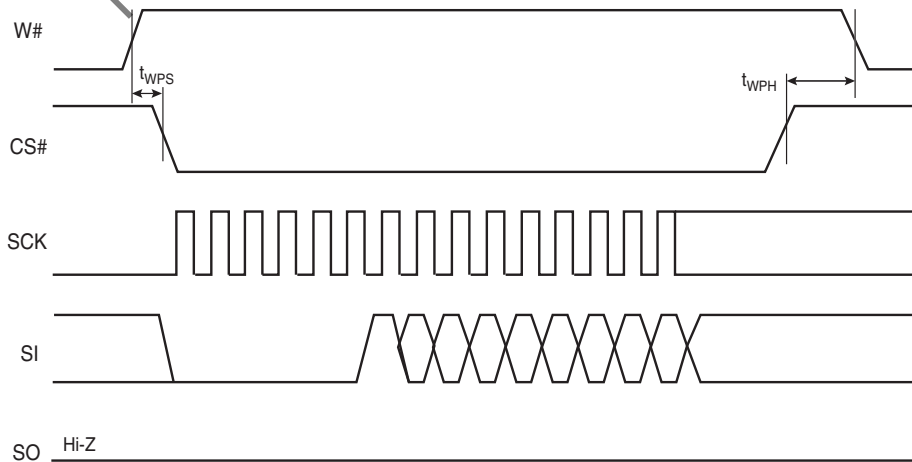
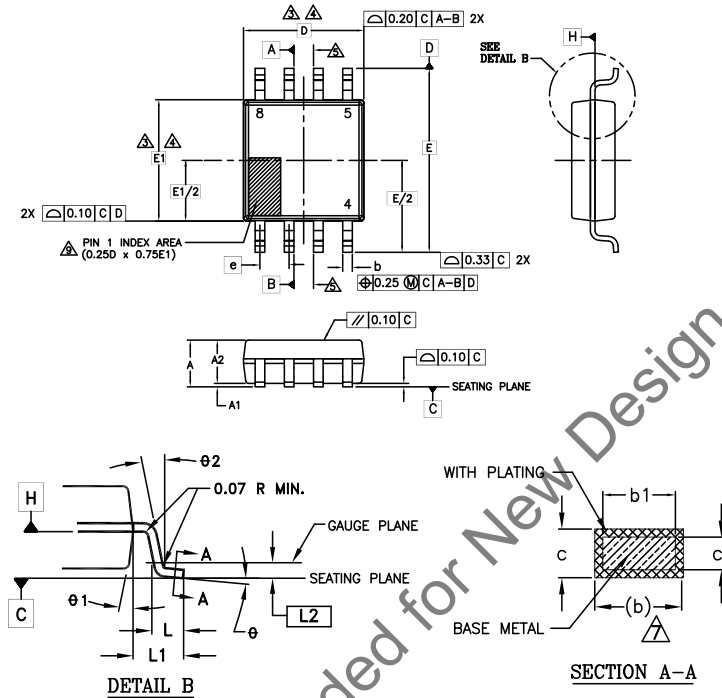

Figure 48. Write Protect Setup and Hold Timing during WRR when SRWD = 1



19. Physical Dimensions

19.1 SOC008 wide — 8-pin Plastic Small Outline Package (208-mils Body Width)



| SYMBOL | DIMENSIONS | | |
|--------|------------|------|------|
| | MIN. | NOM. | MAX. |
| A | 1.75 | - | 2.16 |
| A1 | 0.05 | - | 0.25 |
| A2 | 1.70 | - | 1.90 |
| b | 0.36 | - | 0.48 |
| b1 | 0.33 | - | 0.46 |
| c | 0.19 | - | 0.24 |
| c1 | 0.15 | - | 0.20 |
| D | 5.28 BSC | | |
| E | 8.00 BSC | | |
| E1 | 5.28 BSC | | |
| e | 1.27 BSC | | |
| L | 0.51 | - | 0.76 |
| L1 | 1.36 REF | | |
| L2 | 0.25 BSC | | |
| N | 8 | | |
| θ | 0° | - | 8° |
| θ 1 | 5° | - | 15° |
| θ 2 | 0-8° REF | | |

NOTES:

- ALL DIMENSIONS ARE IN MILLIMETERS.
- DIMENSIONING AND TOLERANCING PER ASME Y14.5M - 1994.
- △ DIMENSION D DOES NOT INCLUDE MOLD FLASH, PROTRUSIONS OR GATE BURRS. MOLD FLASH, PROTRUSIONS OR GATE BURRS SHALL NOT EXCEED 0.15 mm PER END. DIMENSION E1 DOES NOT INCLUDE INTERLEAD FLASH OR PROTRUSION. INTERLEAD FLASH OR PROTRUSION SHALL NOT EXCEED 0.25 mm PER SIDE. D AND E1 DIMENSIONS ARE DETERMINED AT DATUM H.
- △ THE PACKAGE TOP MAY BE SMALLER THAN THE PACKAGE BOTTOM. DIMENSIONS D AND E1 ARE DETERMINED AT THE OUTMOST EXTREMES OF THE PLASTIC BODY EXCLUSIVE OF MOLD FLASH, TIE BAR BURRS, GATE BURRS AND INTERLEAD FLASH, BUT INCLUSIVE OF ANY MISMATCH BETWEEN THE TOP AND BOTTOM OF THE PLASTIC BODY.
- △ DATUMS A AND B TO BE DETERMINED AT DATUM H.
- "N" IS THE MAXIMUM NUMBER OF TERMINAL POSITIONS FOR THE SPECIFIED PACKAGE LENGTH.
- △ THE DIMENSIONS APPLY TO THE FLAT SECTION OF THE LEAD BETWEEN 0.10 TO 0.25 mm FROM THE LEAD TIP.
- △ DIMENSION "b" DOES NOT INCLUDE DAMBAR PROTRUSION. ALLOWABLE DAMBAR PROTRUSION SHALL BE 0.10 mm TOTAL IN EXCESS OF THE "b" DIMENSION AT MAXIMUM MATERIAL CONDITION. THE DAMBAR CANNOT BE LOCATED ON THE LOWER RADIUS OF THE LEAD FOOT.
- △ THIS CHAMFER FEATURE IS OPTIONAL. IF IT IS NOT PRESENT, THEN A PIN 1 IDENTIFIER MUST BE LOCATED WITHIN THE INDEX AREA INDICATED.
- LEAD COPLANARITY SHALL BE WITHIN 0.10 mm AS MEASURED FROM THE SEATING PLANE.

002-15548 **

19.2 SO3 016 — 16-pin Wide Plastic Small Outline Package (300-mils Body Width)

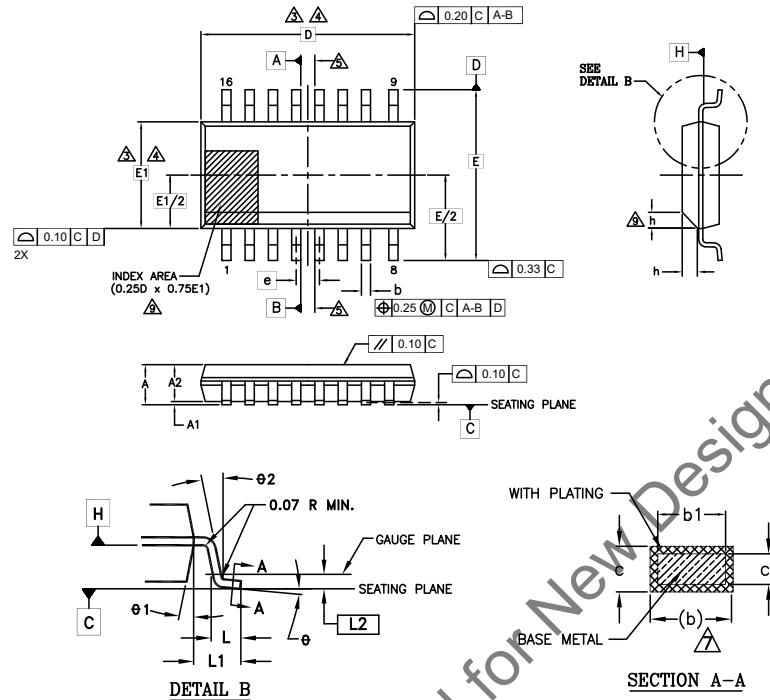

| SYMBOL | DIMENSIONS | | |
|------------|------------|------|------|
| | MIN. | NOM. | MAX. |
| A | 2.35 | - | 2.65 |
| A1 | 0.10 | - | 0.30 |
| A2 | 2.05 | - | 2.55 |
| b | 0.31 | - | 0.51 |
| b1 | 0.27 | - | 0.48 |
| c | 0.20 | - | 0.33 |
| c1 | 0.20 | - | 0.30 |
| D | 10.30 BSC | | |
| E | 10.30 BSC | | |
| E1 | 7.50 BSC | | |
| e | 1.27 BSC | | |
| L | 0.40 | - | 1.27 |
| L1 | 1.40 REF | | |
| L2 | 0.25 BSC | | |
| N | 16 | | |
| h | 0.25 | - | 0.75 |
| θ | 0° | - | 8° |
| $\theta 1$ | 5° | - | 15° |
| $\theta 2$ | 0° | - | - |

- NOTES:
1. ALL DIMENSIONS ARE IN MILLIMETERS.
 2. DIMENSIONING AND TOLERANCING PER ASME Y14.5M - 1994.
 3. DIMENSION D DOES NOT INCLUDE MOLD FLASH, PROTRUSIONS OR GATE BURRS. MOLD FLASH, PROTRUSIONS OR GATE BURRS SHALL NOT EXCEED 0.15 mm PER END. DIMENSION E1 DOES NOT INCLUDE INTERLEAD FLASH OR PROTRUSION. INTERLEAD FLASH OR PROTRUSION SHALL NOT EXCEED 0.25 mm PER SIDE. D AND E1 DIMENSIONS ARE DETERMINED AT DATUM H.
 4. THE PACKAGE TOP MAY BE SMALLER THAN THE PACKAGE BOTTOM. DIMENSIONS D AND E1 ARE DETERMINED AT THE OUTMOST EXTREMES OF THE PLASTIC BODY EXCLUSIVE OF MOLD FLASH, TIE BAR BURRS, GATE BURRS AND INTERLEAD FLASH, BUT INCLUSIVE OF ANY MISMATCH BETWEEN THE TOP AND BOTTOM OF THE PLASTIC BODY.
 5. DATUMS A AND B TO BE DETERMINED AT DATUM H.
 6. "N" IS THE MAXIMUM NUMBER OF TERMINAL POSITIONS FOR THE SPECIFIED PACKAGE LENGTH.
 7. THE DIMENSIONS APPLY TO THE FLAT SECTION OF THE LEAD BETWEEN 0.10 TO 0.25 mm FROM THE LEAD TIP.
 8. DIMENSION "b" DOES NOT INCLUDE DAMBAR PROTRUSION. ALLOWABLE DAMBAR PROTRUSION SHALL BE 0.10 mm TOTAL IN EXCESS OF THE "b" DIMENSION AT MAXIMUM MATERIAL CONDITION. THE DAMBAR CANNOT BE LOCATED ON THE LOWER RADIUS OF THE LEAD FOOT.
 9. THIS CHAMFER FEATURE IS OPTIONAL. IF IT IS NOT PRESENT, THEN A PIN 1 IDENTIFIER MUST BE LOCATED WITHIN THE INDEX AREA INDICATED.
 10. LEAD COPLANARITY SHALL BE WITHIN 0.10 mm AS MEASURED FROM THE SEATING PLANE.

002-15547 *A

19.3 UNE008 — USON 8-contact (5 × 6 mm) No-Lead Package

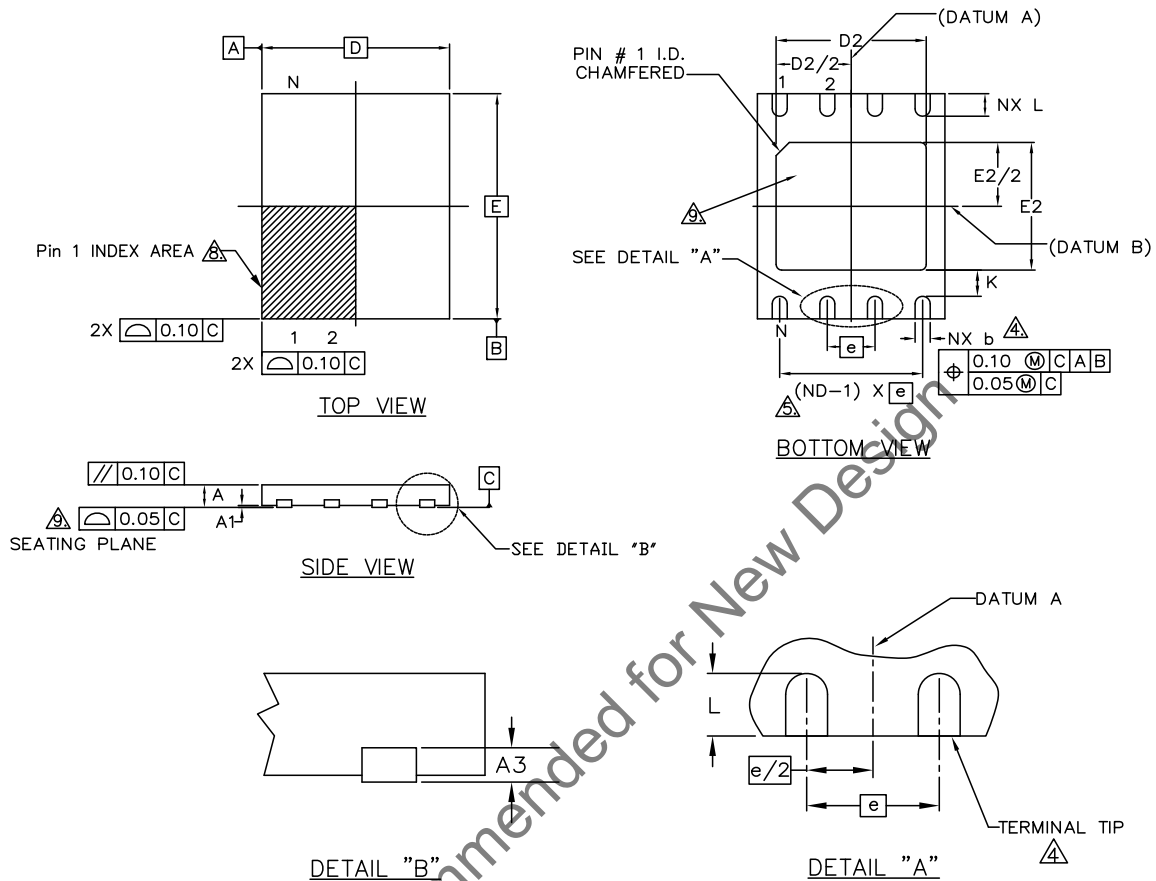

| SYMBOL | DIMENSIONS | | |
|--------|------------|------|------|
| | MIN. | NOM. | MAX. |
| e | 1.27 BSC | | |
| N | 8 | | |
| ND | 4 | | |
| L | 0.55 | 0.60 | 0.65 |
| b | 0.35 | 0.40 | 0.45 |
| D2 | 3.90 | 4.00 | 4.10 |
| E2 | 3.30 | 3.40 | 3.50 |
| D | 5.00 BSC | | |
| E | 6.00 BSC | | |
| A | 0.45 | 0.50 | 0.55 |
| A1 | 0.00 | 0.02 | 0.05 |
| A3 | 0.20 REF | | |
| K | 0.20 MIN. | | |

NOTES:

1. DIMENSIONING AND TOLERANCING CONFORMS TO ASME Y14.5M-1994.
2. ALL DIMENSIONS ARE IN MILLIMETERS.
3. N IS THE TOTAL NUMBER OF TERMINALS.
4. DIMENSION "b" APPLIES TO METALLIZED TERMINAL AND IS MEASURED BETWEEN 0.15 AND 0.30mm FROM TERMINAL TIP. IF THE TERMINAL HAS THE OPTIONAL RADIUS ON THE OTHER END OF THE TERMINAL, THE DIMENSION "b" SHOULD NOT BE MEASURED IN THAT RADIUS AREA.
5. ND REFERS TO THE NUMBER OF TERMINALS ON D SIDE.
6. MAX. PACKAGE WARPAGE IS 0.05mm.
7. MAXIMUM ALLOWABLE BURR IS 0.076mm IN ALL DIRECTIONS.
8. PIN #1 ID ON TOP WILL BE LOCATED WITHIN THE INDICATED ZONE.
9. BILATERAL COPLANARITY ZONE APPLIES TO THE EXPOSED HEAT SINK SLUG AS WELL AS THE TERMINALS.

002-18903 **

19.4 WNF008 — WSON 8-contact (6 × 8 mm) No-Lead Package

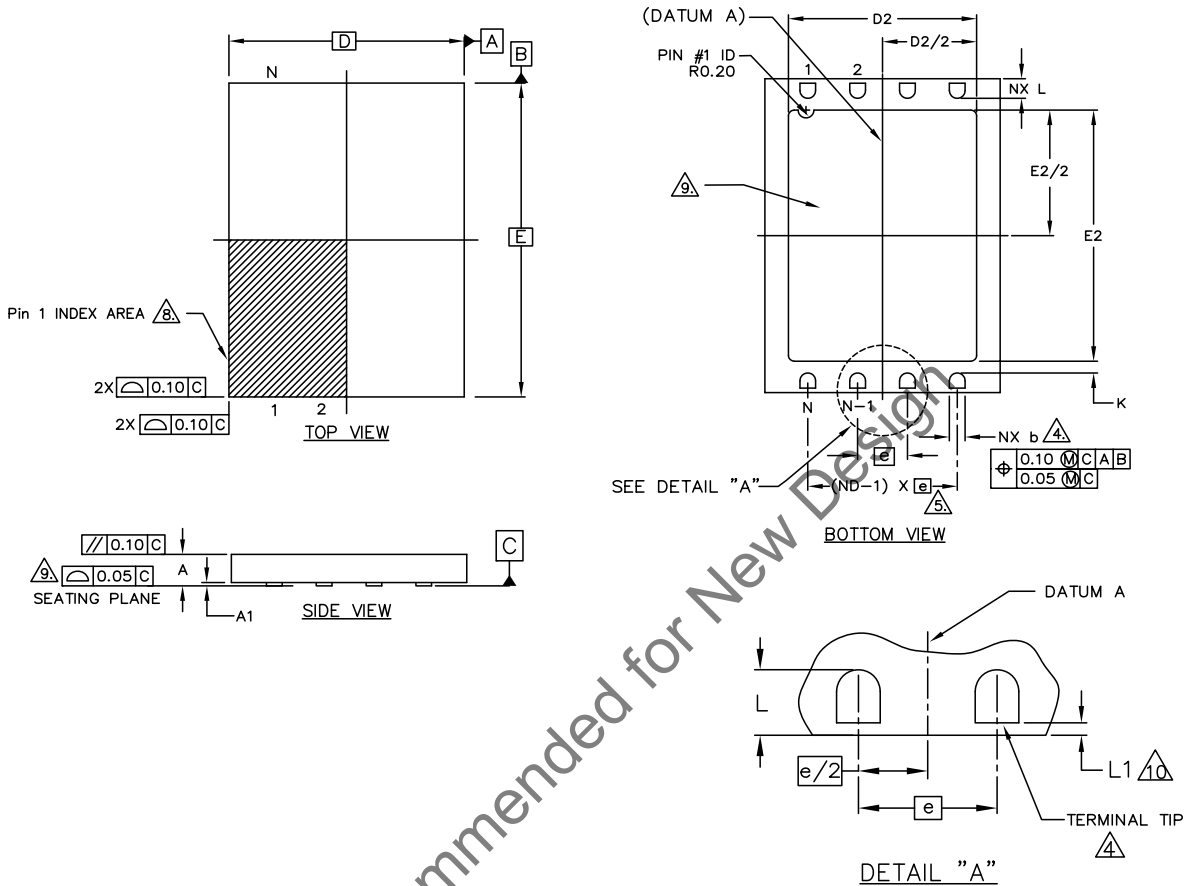

| SYMBOL | DIMENSIONS | | |
|--------|------------|------|------|
| | MIN. | NOM. | MAX. |
| e | 1.27 BSC. | | |
| N | 8 | | |
| ND | 4 | | |
| L | 0.45 | 0.50 | 0.55 |
| b | 0.35 | 0.40 | 0.45 |
| D2 | 4.70 | 4.80 | 4.90 |
| E2 | 5.70 | 5.80 | 5.90 |
| D | 6.00 BSC | | |
| E | 8.00 BSC | | |
| A | 0.70 | 0.75 | 0.80 |
| A1 | 0.00 | 0.02 | 0.05 |
| K | 0.20 MIN. | | |
| L1 | 0.00 | - | 0.15 |

NOTES:

1. DIMENSIONING AND TOLERANCING CONFORMS TO ASME Y14.5M-1994.
2. ALL DIMENSIONS ARE IN MILLIMETERS.
3. N IS THE TOTAL NUMBER OF TERMINALS.
4. DIMENSION "b" APPLIES TO METALLIZED TERMINAL AND IS MEASURED BETWEEN 0.15 AND 0.30mm FROM TERMINAL TIP. IF THE TERMINAL HAS THE OPTIONAL RADIUS ON THE OTHER END OF THE TERMINAL, THE DIMENSION "b" SHOULD NOT BE MEASURED IN THAT RADIUS AREA.
5. ND REFERS TO THE NUMBER OF TERMINALS ON D SIDE.
6. MAX. PACKAGE WARPAGE IS 0.05mm.
7. MAXIMUM ALLOWABLE BURR IS 0.076mm IN ALL DIRECTIONS.
8. PIN #1 ID ON TOP WILL BE LOCATED WITHIN THE INDICATED ZONE.
9. BILATERAL COPLANARITY ZONE APPLIES TO THE EXPOSED HEAT SINK SLUG AS WELL AS THE TERMINALS.
10. A MAXIMUM 0.15mm PULL BACK (L1) MAY BE PRESENT.

002-18902 **

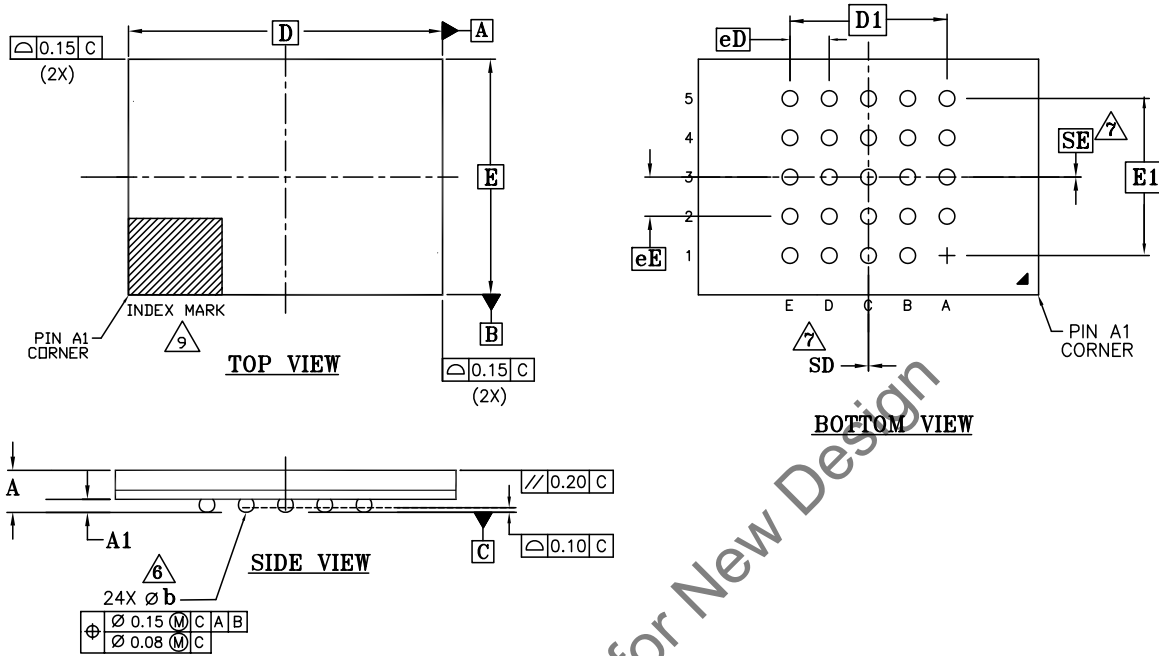
19.5 FAB024 — 24-ball Ball Grid Array (6 x 8 mm) Package

| SYMBOL | DIMENSIONS | | |
|--------|------------|------|------|
| | MIN. | NOM. | MAX. |
| A | - | - | 1.20 |
| A1 | 0.20 | - | - |
| D | 8.00 BSC | | |
| E | 6.00 BSC | | |
| D1 | 4.00 BSC | | |
| E1 | 4.00 BSC | | |
| MD | 5 | | |
| ME | 5 | | |
| N | 24 | | |
| ∅ b | 0.35 | 0.40 | 0.45 |
| eE | 1.00 BSC | | |
| eD | 1.00 BSC | | |
| SD | 0.00 BSC | | |
| SE | 0.00 BSC | | |

NOTES:

- DIMENSIONING AND TOLERANCING METHODS PER ASME Y14.5M-1994.
- ALL DIMENSIONS ARE IN MILLIMETERS.
- BALL POSITION DESIGNATION PER JEP95, SECTION 3, SPP-020.
- e** REPRESENTS THE SOLDER BALL GRID PITCH.
- SYMBOL "MD" IS THE BALL MATRIX SIZE IN THE "D" DIRECTION. SYMBOL "ME" IS THE BALL MATRIX SIZE IN THE "E" DIRECTION. N IS THE NUMBER OF POPULATED SOLDER BALL POSITIONS FOR MATRIX SIZE MD X ME.
- DIMENSION "b" IS MEASURED AT THE MAXIMUM BALL DIAMETER IN A PLANE PARALLEL TO DATUM C.
- "SD" AND "SE" ARE MEASURED WITH RESPECT TO DATUMS A AND B AND DEFINE THE POSITION OF THE CENTER SOLDER BALL IN THE OUTER ROW. WHEN THERE IS AN ODD NUMBER OF SOLDER BALLS IN THE OUTER ROW, "SD" OR "SE" = 0. WHEN THERE IS AN EVEN NUMBER OF SOLDER BALLS IN THE OUTER ROW, "SD" = eD/2 AND "SE" = eE/2.
- "+" INDICATES THE THEORETICAL CENTER OF DEPOPULATED BALLS.
- A1 CORNER TO BE IDENTIFIED BY CHAMFER, LASER OR INK MARK, METALLIZED MARK INDENTATION OR OTHER MEANS.

002-15534 **

19.6 FAC024 — 24-ball Ball Grid Array (6 x 8 mm) Package

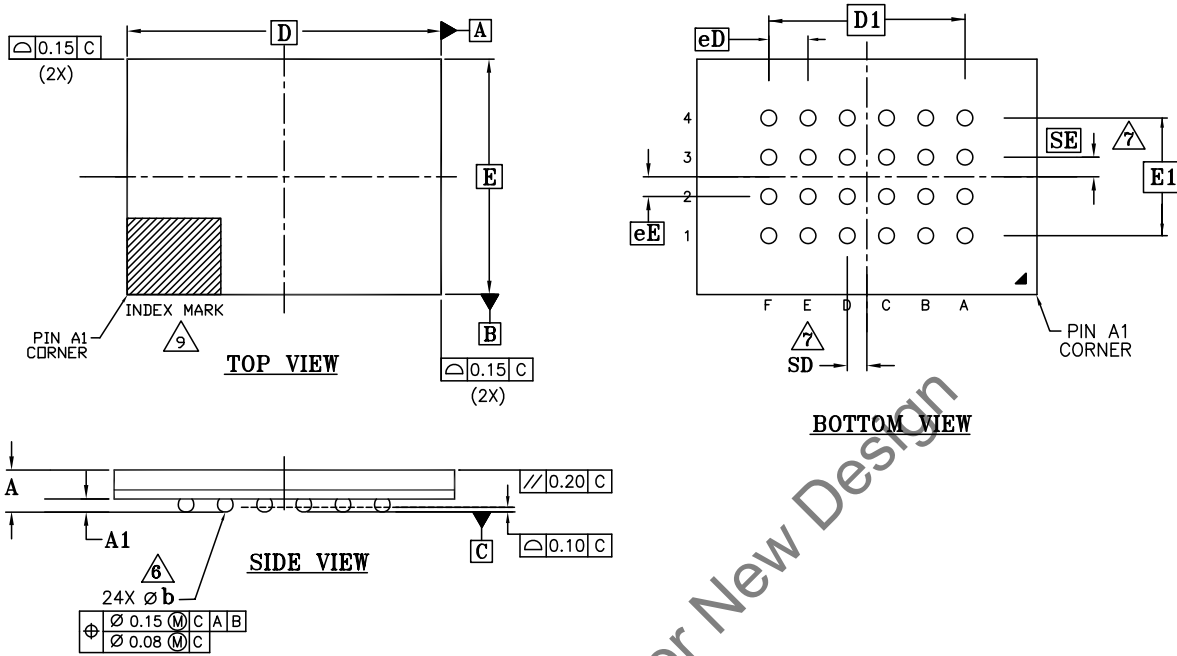

| SYMBOL | DIMENSIONS | | |
|--------|------------|------|------|
| | MIN. | NOM. | MAX. |
| A | - | - | 1.20 |
| A1 | 0.25 | - | - |
| D | 8.00 BSC | | |
| E | 6.00 BSC | | |
| D1 | 5.00 BSC | | |
| E1 | 3.00 BSC | | |
| MD | 6 | | |
| ME | 4 | | |
| N | 24 | | |
| Ø b | 0.35 | 0.40 | 0.45 |
| eE | 1.00 BSC | | |
| eD | 1.00 BSC | | |
| SD | 0.50 BSC | | |
| SE | 0.50 BSC | | |

NOTES:

- DIMENSIONING AND TOLERANCING METHODS PER ASME Y14.5M-1994.
 - ALL DIMENSIONS ARE IN MILLIMETERS.
 - BALL POSITION DESIGNATION PER JEP95, SECTION 3, SPP-020.
 - [e] REPRESENTS THE SOLDER BALL GRID PITCH.
 - SYMBOL "MD" IS THE BALL MATRIX SIZE IN THE "D" DIRECTION. SYMBOL "ME" IS THE BALL MATRIX SIZE IN THE "E" DIRECTION. N IS THE NUMBER OF POPULATED SOLDER BALL POSITIONS FOR MATRIX SIZE MD X ME.
- 6 DIMENSION "b" IS MEASURED AT THE MAXIMUM BALL DIAMETER IN A PLANE PARALLEL TO DATUM C.
- 7 "SD" AND "SE" ARE MEASURED WITH RESPECT TO DATUMS A AND B AND DEFINE THE POSITION OF THE CENTER SOLDER BALL IN THE OUTER ROW.
WHEN THERE IS AN ODD NUMBER OF SOLDER BALLS IN THE OUTER ROW, "SD" OR "SE" = 0.
WHEN THERE IS AN EVEN NUMBER OF SOLDER BALLS IN THE OUTER ROW, "SD" = eD/2 AND "SE" = eE/2.
- 8 "+" INDICATES THE THEORETICAL CENTER OF DEPOPULATED BALLS.
9. A1 CORNER TO BE IDENTIFIED BY CHAMFER, LASER OR INK MARK, METALLIZED MARK INDENTATION OR OTHER MEANS.

002-15535 **

20. Revision History

Document History Page

| Document Title: S25FL032P, 32-Mbit 3.0 V Flash Memory Document Number: 002-00650 | | | | |
|---|---------|-----------------|-----------------|---|
| Rev. | ECN No. | Orig. of Change | Submission Date | Description of Change |
| ** | — | BWHA | 06/09/2008 | Initial release |
| *A | — | BWHA | 02/12/2009 | <p>Connection Diagrams: Added USON package</p> <p>Valid Combinations Table: Added Tray packing type</p> <p>Configuration Register: Added OTP description for BPNV bit</p> <p>Configuration Register Table: Corrected TBPARM description. Added "Default" setting information upon initial factory shipment.</p> <p>Instruction Set: Separated Mode bit and Dummy bytes</p> <p>Product Group CFI Primary Vendor-Specific Extended Query: Corrected data of 45h bytes</p> <p>Read-ID (READ_ID): Removed statement of 8-cycle buffer for Manufacturer ID and the Device ID</p> <p>Read Status Register: Corrected description for SRWD bit in the Status Register Table. Modified E_ERR and P_ERR descriptions</p> <p>Read Configuration Register: Updated figure</p> <p>Parameter Sector Erase (P4E, P8E): Updated figure</p> <p>Release from Deep Power-Down and Read Electronic Signature (RES): Updated figure</p> <p>OTP Regions: Modified description for the ACC function</p> <p>Power-up and Power-down: Changed specification for t_{PU}</p> <p>Absolute Maximum Ratings: Corrected the Table</p> <p>DC Characteristics: Changed maximum specifications for I_{CC1} and I_{CC3}.</p> <p>Modified Test Conditions for I_{SB1} and I_{PD}</p> <p>AC Characteristics: Changed maximum specifications for t_W. Added note for max values assume 100k cycles. Changed Clock High/Low time.</p> |
| *B | — | BWHA | 05/26/2009 | <p>Connection Diagrams: Corrected package name</p> <p>Dual Output Read Mode (DOR): Added statement for Dual Output Read command</p> <p>Quad Output Read Mode (QOR): Added statement for Quad Output Read command</p> <p>Power Up & Power Down: Updated V_{CC(low)} Min in Table: Power-Up / Power-Down Voltage and Timing</p> <p>AC Characteristics: Updated t_{WH}, t_{CH} and t_{WL}, t_{CL}</p> <p>Revision History: Corrected "Revision 02 (February 12, 2009)" for AC Characteristics</p> |
| *C | — | BWHA | 07/22/2009 | <p>Distinctive Characteristics: Added BGA package information</p> <p>Connection Diagrams: Added BGA package</p> <p>Ordering Information: Added Automotive In-cabin information. Added BGA package information.</p> <p>Valid Combinations: Corrected Valid Combinations Table</p> <p>Configuration Register: Added Suggested Cross Settings Table</p> <p>Accelerated Programming Operation: Added note for ACC function</p> <p>Read Identification (RDID): Updated Read Identification description. Updated figure for RDID. Updated CFI table for 29h.</p> <p>Write Registers (WRR): Added note for HPM</p> <p>Parameter Sector Erase (P4E, P8E): Updated description for P4E/P8E command.</p> <p>Sector Erase (SE): Updated description for SE command</p> <p>Release from Deep Power-Down (RES): Added note for RES command</p> |

Document History Page (Continued)

| Document Title: S25FL032P, 32-Mbit 3.0 V Flash Memory Document Number: 002-00650 | | | | |
|---|---------|-----------------|-----------------|---|
| Rev. | ECN No. | Orig. of Change | Submission Date | Description of Change |
| *C (Cont.) | — | BWHA | 07/22/2009 | Operating Ranges: Updated descriptions. Added ESN1 and ESN2 Table. AC Characteristics: Added Automotive In-cabin spec for f_C . Updated t_{WH} , t_{CH} and t_{WL} , t_{CL} . Physical Dimensions: Added BGA 6 x 8 mm package |
| *D | — | BWHA | 10/05/2009 | Global: Changed all references to RDID clock rate from 40 to 50 MHz Connection Diagrams: Added "5 x 5 pin configuration" to Figure 2.5 title. Added 6 x 4 pin configuration BGA connection diagram. Added note regarding exposed central pad on bottom of package to the WSON and USON connection diagram. Ordering Information: Added Automotive In-Cabin temperature valid combinations for BGA packages. Added 02 and 03 model numbers for BGA packages. Removed BGA from 00 model number description. Added Low-Halogen material option. Valid Combinations: Changed valid BGA model number combinations to 02 and 03. Changed valid BGA material option to Low-Halogen. Removed Note 1. Physical Dimensions: Added FAC024 BGA package AC Characteristics: Removed 76 MHz Automotive in-cabin spec from f_C and Note 9. |
| *E | — | BWHA | 12/07/2011 | Instruction Set Table: Updated QIOR command Power-Up / Power-Down Voltage and Timing Table: Updated t_{PU} (max) Initial Delivery State: Modified section Capacitance: Added notes to table Physical Dimensions: Updated the package outline drawing for SOIC, WSON, USON, and BGA 5x5 packages. |
| *F | — | BWHA | 09/21/2012 | AC Characteristics: Changed Output Hold Time (t_{HO}) to 2 ns (min). |
| *G | — | BWHA | 10/30/2012 | Command Definitions: Instruction Set table: Corrected the value of CLSR command Write Registers (WRR): Protection Modes table: Added Parameter Sector Erase to Memory Content columns for clarification Parameter Sector Erase (P4E, P8E): Updated the table reference. |
| *H | — | BWHA | 01/29/2013 | Capacitance: Added "Typical" values column. Corrected "Max" values for C_{IN} / C_{OUT} (Input / Output Capacitance). |
| *I | 4904072 | BWHA | 09/18/2015 | Updated to Cypress template. |
| *J | 5615358 | ECAO | 03/24/2017 | Corrected t_{CFT} and t_{CRT} positions in Figure 45 on page 50 . Updated Cypress logo and Sales page. |
| *K | 5711277 | ECAO | 04/25/2017 | Added Valid Automotive Ordering Combinations in Section 5.1, Valid Combinations on page 9 Updated all package outline drawings in Section 19., Physical Dimensions on page 52 |
| *L | 5742306 | ECAO | 05/19/2017 | Added Valid Automotive Ordering Combinations in Section 5.1, Valid Combinations on page 9 . Added "Not Recommended for New Design (NRND)" status. |

Sales, Solutions, and Legal Information

Worldwide Sales and Design Support

Cypress maintains a worldwide network of offices, solution centers, manufacturer's representatives, and distributors. To find the office closest to you, visit us at [Cypress Locations](#).

Products

| | |
|-------------------------------|--|
| ARM® Cortex® Microcontrollers | cypress.com/arm |
| Automotive | cypress.com/automotive |
| Clocks & Buffers | cypress.com/clocks |
| Interface | cypress.com/interface |
| Internet of Things | cypress.com/iot |
| Memory | cypress.com/memory |
| Microcontrollers | cypress.com/mcu |
| PSoC | cypress.com/psoc |
| Power Management ICs | cypress.com/pmic |
| Touch Sensing | cypress.com/touch |
| USB Controllers | cypress.com/usb |
| Wireless Connectivity | cypress.com/wireless |

PSoC® Solutions

[PSoC 1](#) | [PSoC 3](#) | [PSoC 4](#) | [PSoC 5LP](#) | [PSoC 6](#)

Cypress Developer Community

[Forums](#) | [WICED IOT Forums](#) | [Projects](#) | [Video](#) | [Blogs](#) | [Training](#) | [Components](#)

Technical Support

cypress.com/support

Not Recommended for New Design

© Cypress Semiconductor Corporation, 2008-2017. This document is the property of Cypress Semiconductor Corporation and its subsidiaries, including Spansion LLC ("Cypress"). This document, including any software or firmware included or referenced in this document ("Software"), is owned by Cypress under the intellectual property laws and treaties of the United States and other countries worldwide. Cypress reserves all rights under such laws and treaties and does not, except as specifically stated in this paragraph, grant any license under its patents, copyrights, trademarks, or other intellectual property rights. If the Software is not accompanied by a license agreement and you do not otherwise have a written agreement with Cypress governing the use of the Software, then Cypress hereby grants you a personal, non-exclusive, nontransferable license (without the right to sublicense) (1) under its copyright rights in the Software (a) for Software provided in source code form, to modify and reproduce the Software solely for use with Cypress hardware products, only internally within your organization, and (b) to distribute the Software in binary code form externally to end users (either directly or indirectly through resellers and distributors), solely for use on Cypress hardware product units, and (2) under those claims of Cypress's patents that are infringed by the Software (as provided by Cypress, unmodified) to make, use, distribute, and import the Software solely for use with Cypress hardware products. Any other use, reproduction, modification, translation, or compilation of the Software is prohibited.

TO THE EXTENT PERMITTED BY APPLICABLE LAW, CYPRESS MAKES NO WARRANTY OF ANY KIND, EXPRESS OR IMPLIED, WITH REGARD TO THIS DOCUMENT OR ANY SOFTWARE OR ACCOMPANYING HARDWARE, INCLUDING, BUT NOT LIMITED TO, THE IMPLIED WARRANTIES OF MERCHANTABILITY AND FITNESS FOR A PARTICULAR PURPOSE. To the extent permitted by applicable law, Cypress reserves the right to make changes to this document without further notice. Cypress does not assume any liability arising out of the application or use of any product or circuit described in this document. Any information provided in this document, including any sample design information or programming code, is provided only for reference purposes. It is the responsibility of the user of this document to properly design, program, and test the functionality and safety of any application made of this information and any resulting product. Cypress products are not designed, intended, or authorized for use as critical components in systems designed or intended for the operation of weapons, weapons systems, nuclear installations, life-support devices or systems, other medical devices or systems (including resuscitation equipment and surgical implants), pollution control or hazardous substances management, or other uses where the failure of the device or system could cause personal injury, death, or property damage ("Unintended Uses"). A critical component is any component of a device or system whose failure to perform can be reasonably expected to cause the failure of the device or system, or to affect its safety or effectiveness. Cypress is not liable, in whole or in part, and you shall and hereby do release Cypress from any claim, damage, or other liability arising from or related to all Unintended Uses of Cypress products. You shall indemnify and hold Cypress harmless from and against all claims, costs, damages, and other liabilities, including claims for personal injury or death, arising from or related to any Unintended Uses of Cypress products.

Cypress, the Cypress logo, Spansion, the Spansion logo, and combinations thereof, WICED, PSoC, CapSense, EZ-USB, F-RAM, and Traveo are trademarks or registered trademarks of Cypress in the United States and other countries. For a more complete list of Cypress trademarks, visit cypress.com. Other names and brands may be claimed as property of their respective owners.

Looking for pricing, stock, or lifecycle information?

Click below to explore more details on WIN SOURCE:

 [View S25FL032P0XMFI003 on WIN SOURCE](#)

 [Spansion Information](#)

Optimize Your Supply Chain with WIN SOURCE Solutions

-  Global Sourcing Solution
-  Obsolete Management
-  Cost Control Management
-  Shortage Management
-  Alternative Solution
-  Excess Inventory Management