



**THE DATASHEET OF
AN41908A-VB**





NEW! Special Function Motor Drivers

AN41908A Lens Driver

AN41919A DC Iris Driver

Panasonic Special Function Motor Drivers Network and Security Cameras



Dome Type Cameras
(Iris Servo for Hall Sensor)



Box Type Camera
(Iris Servo for Dumping Coil)

	Type	Function	Package (Chip size)
Lens Driver for Dome type	AN41908A	5ch motor drive controller (Zoom 2ch + Focus 2ch + Iris servo for hall sensor 1ch)	QFN44 (6mm × 6mm)
DC Iris Driver for Box type	AN41919A	1ch Iris controller (Iris servo for dumping coil 1ch)	

Panasonic AN41908A Lens Driver for Dome Type Camera (Iris Servo for Hall Sensor)



Block Diagram of Network Camera (Half)

Block diagram

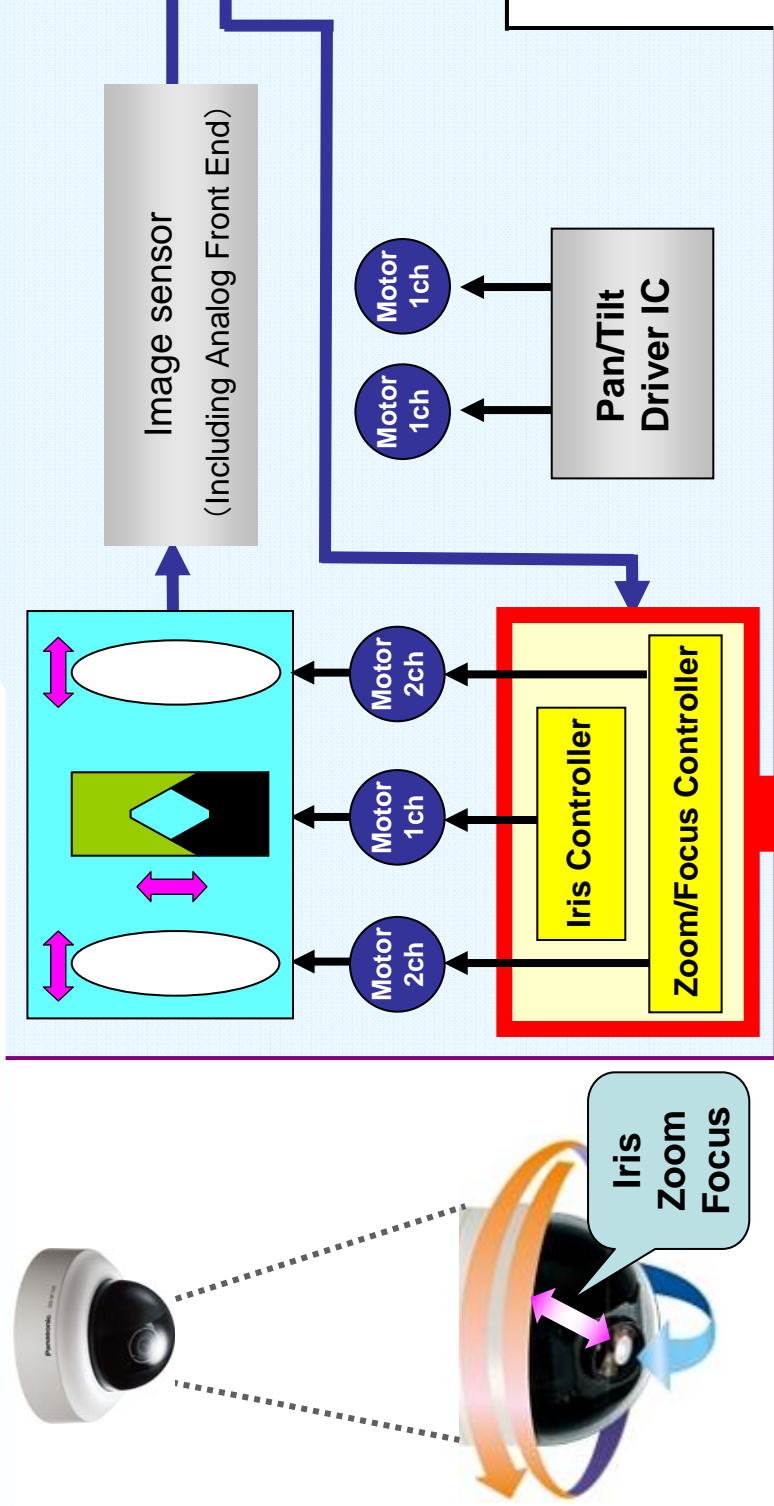

Single chip solution
Lens Driver
AN41908A

Panasonic AN41908A Block Diagram

To Integrate Iris Control Function on Zoom & Focus

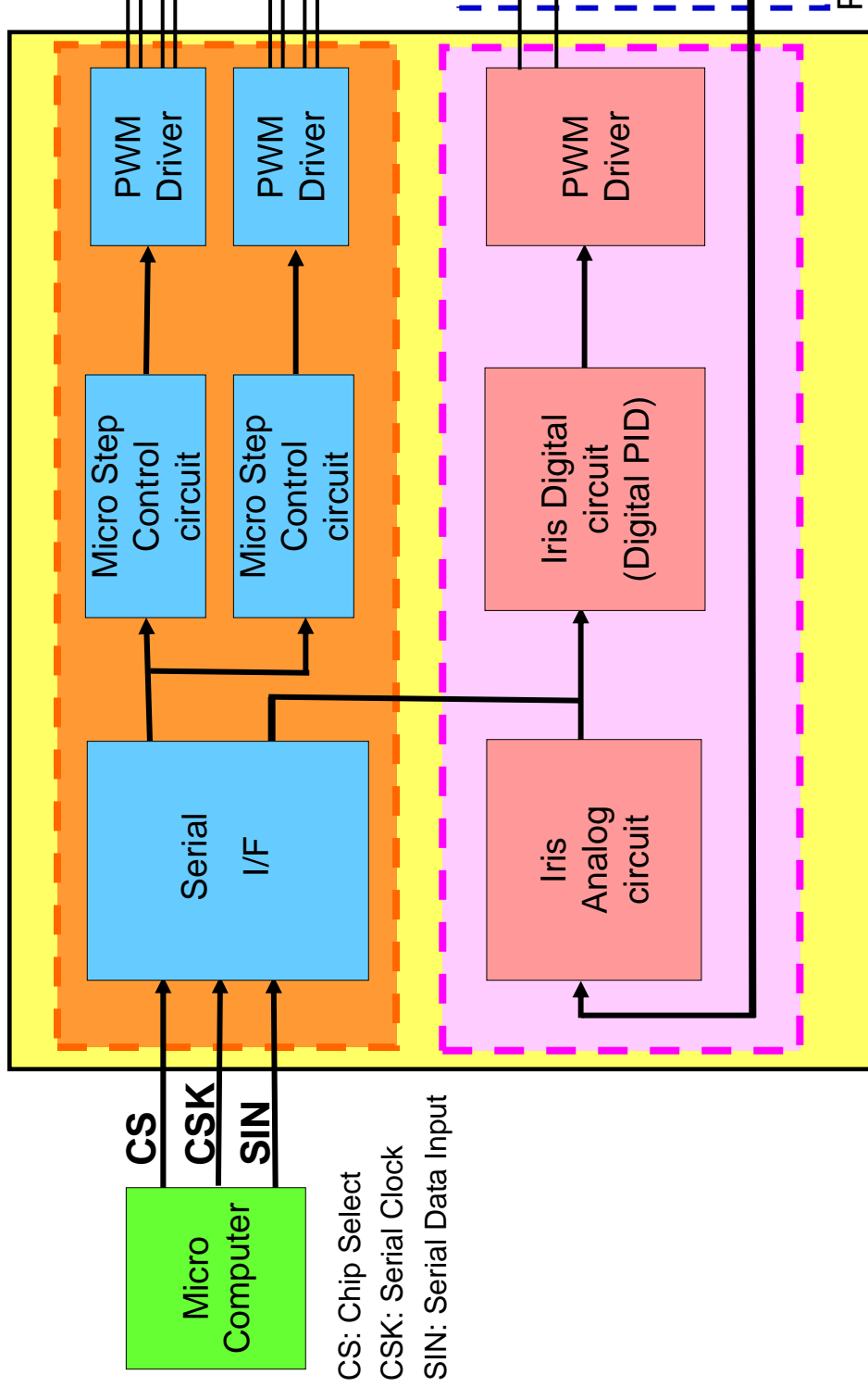

PID: Proportional Integral Derivative

Panasonic AN41908A Single Chip Adv

- PCB Space Reduction
- Reduced Design-In Time
- Low Acoustic Noise
- Low Power Consumption

PCB Space Reduction

Company A

Total Area = 381mm²

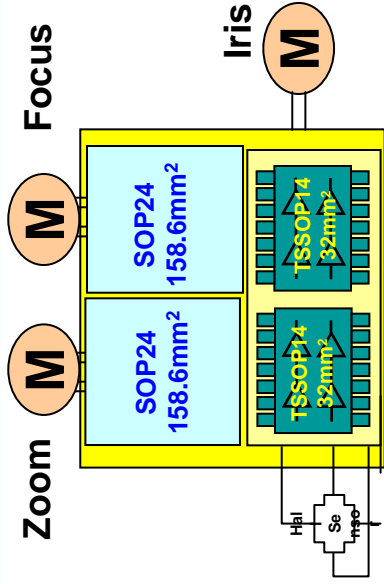

90.5%
Reduction

AN419

1Chip LSI
Focus and Iris

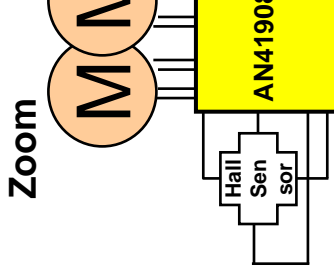

Total Area
(About 80-90%)

Company B

Total Area = 162mm²

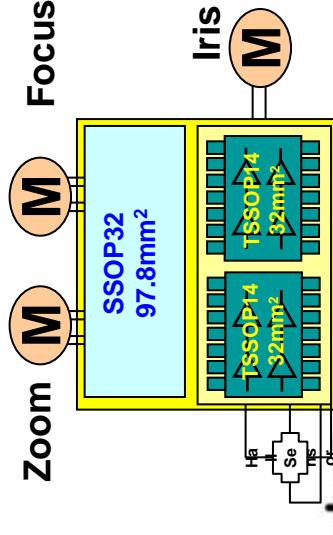

78%
Reduction

Advantage for

- Small Cam
- PCB cost r

Reduced Design-In Time

Easy Adjustment of Iris Circuit

Existing system

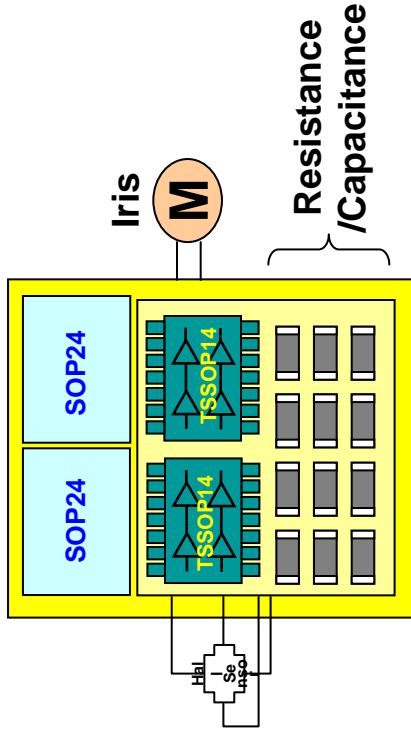

AN41908A

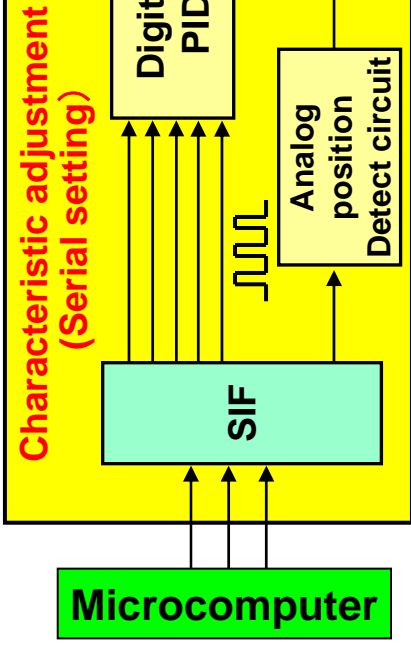

SIF: Serial Inter Face

PID: Proportion / integral calculus
calculus 3 elements digital o

Inconvenient...

You needed to adjust Iris circuit when you start to design camera...

You needed to change external resistance and capacitance for Iris adjustment...

Improved !!

Software can arrange the circuit by software because of built-in digital

Low Noise Micro Step Drive for Zoom and F

Less Acoustic Noise by Motor Tolerance Correction

Ideal motor current waveform

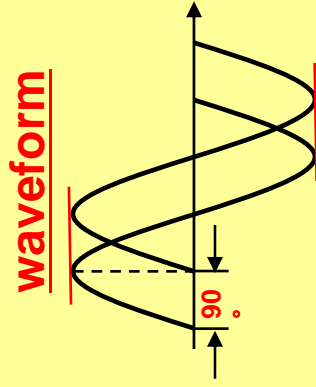

- * Equal amplitude
- * Phase difference 90deg

Motor tolerance

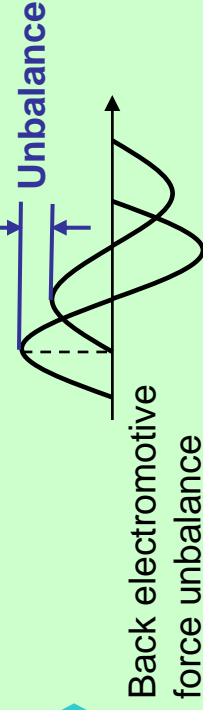

Back electromotive force unbalance

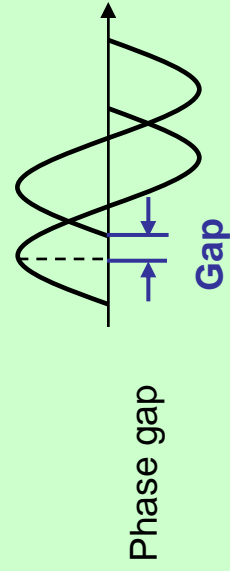

Phase gap

No correction

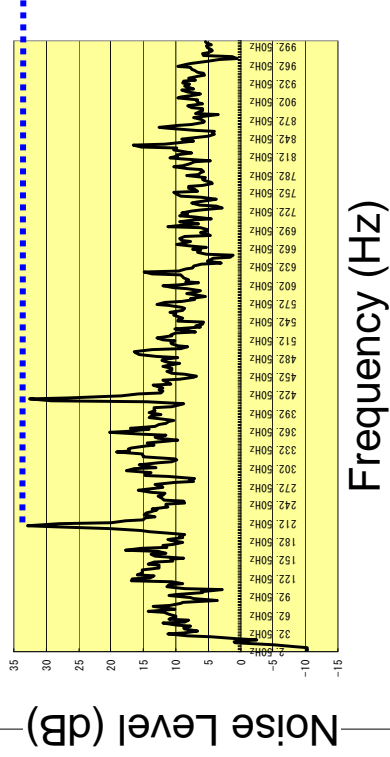

Correction

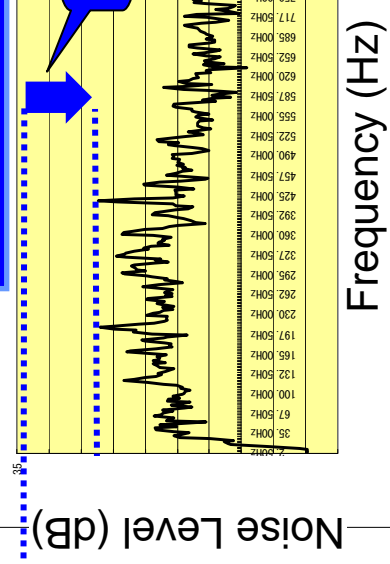

Low Power Consumption

50% power reduction by PWM driving system

(Compared with Linear driving system)

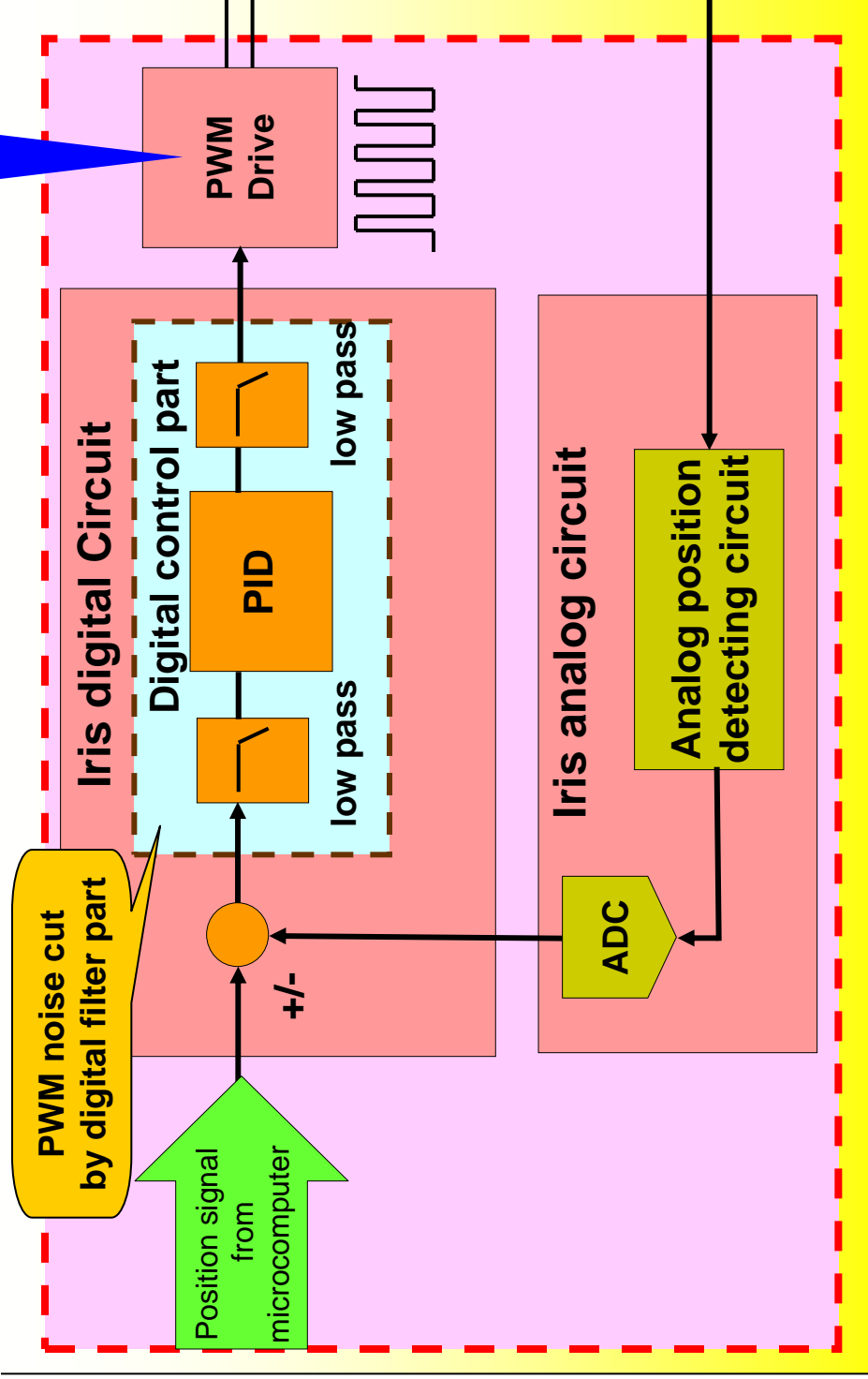

Panasonic AN41908A Application

Panasonic can prepare evaluation board and more specific applications

Overview

AN41908A is a lens motor driver IC for camcorder and security-camera featuring the functions of Iris control. Voltage drive system and several torque ripple correction techniques enable super- low noise microstep drive.

Features

- Voltage drive system 256-step microstep drivers (2 systems)
- Built-in Iris controller
- Motor control by 4-line serial data communication
- 2 systems of open-drain for driving LED

Applications

- Camcorders, Security Cameras

Package

- 44 pin Plastic Quad Flat Non-leaded Package

Type

- Bi-COMS IC

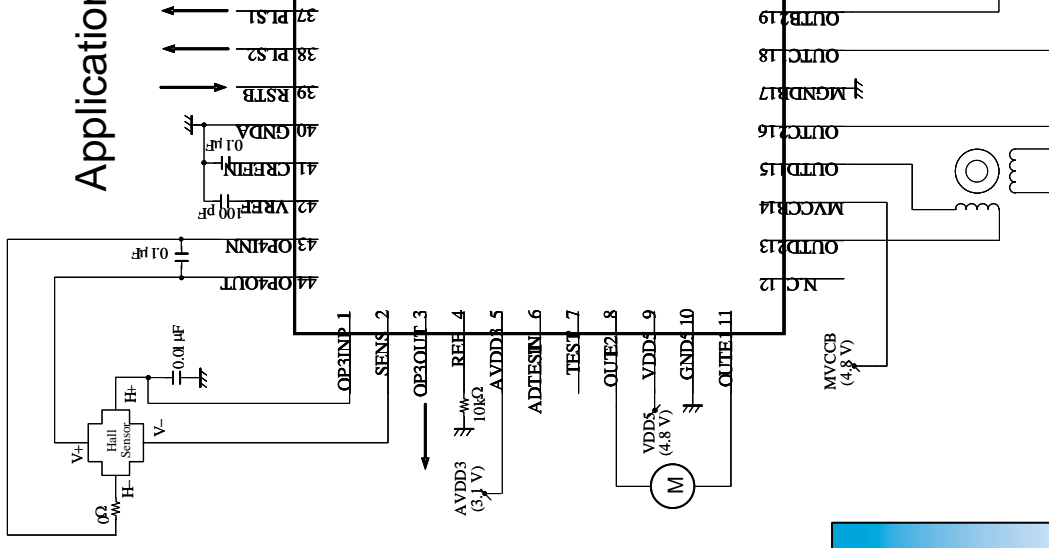
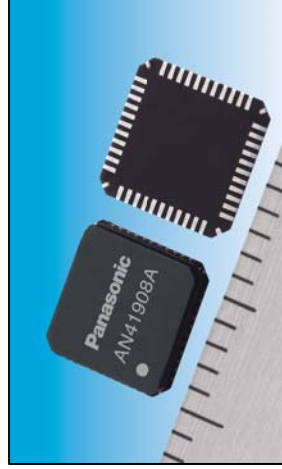

Evaluation Board

Connection for quick start-up

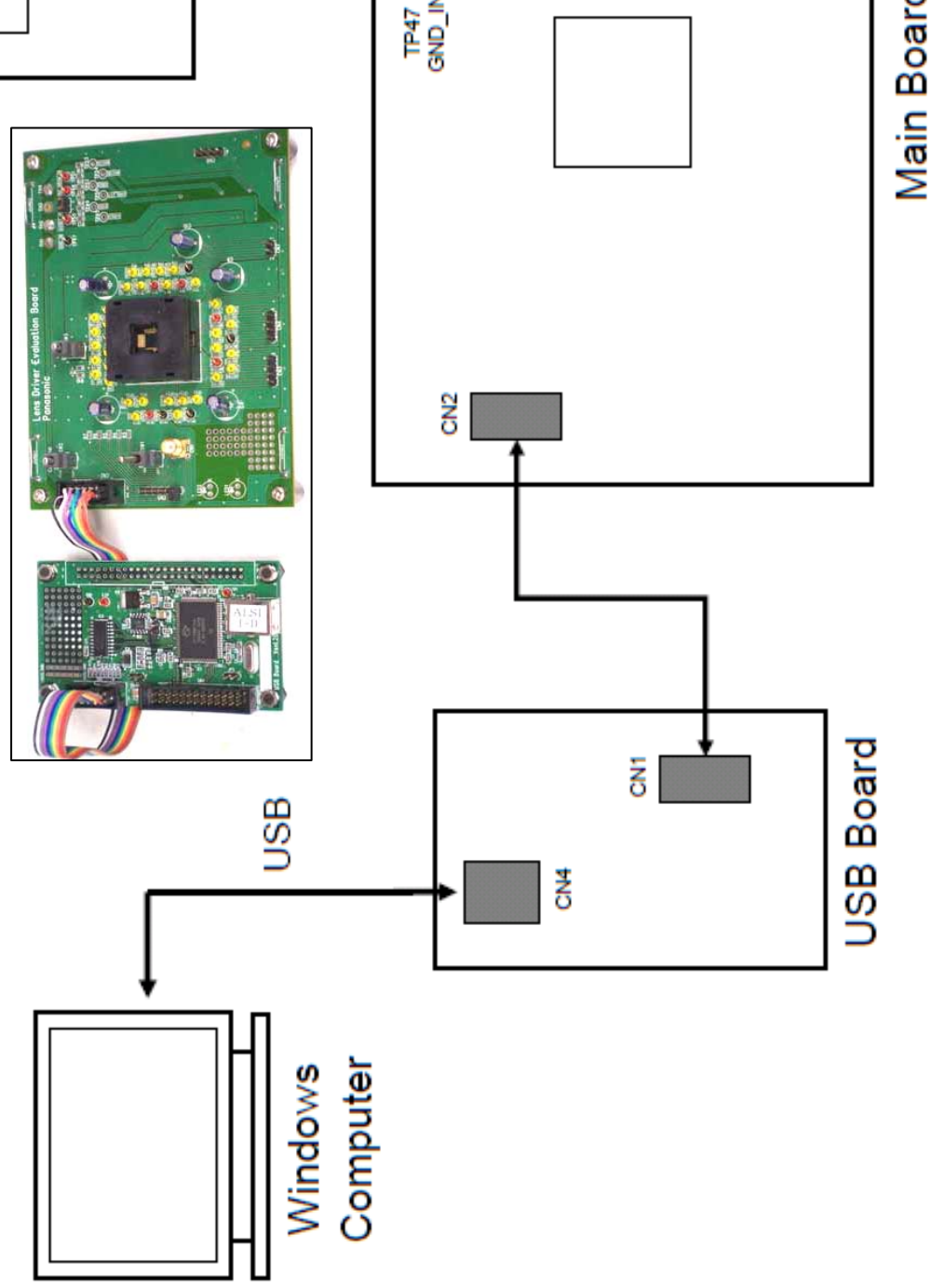

Panasonic AN41919A DC Iris Driver for Box Type Camera

(Iris Servo for Dumping Coil)



Block Diagram of Network Camera

Block diagram

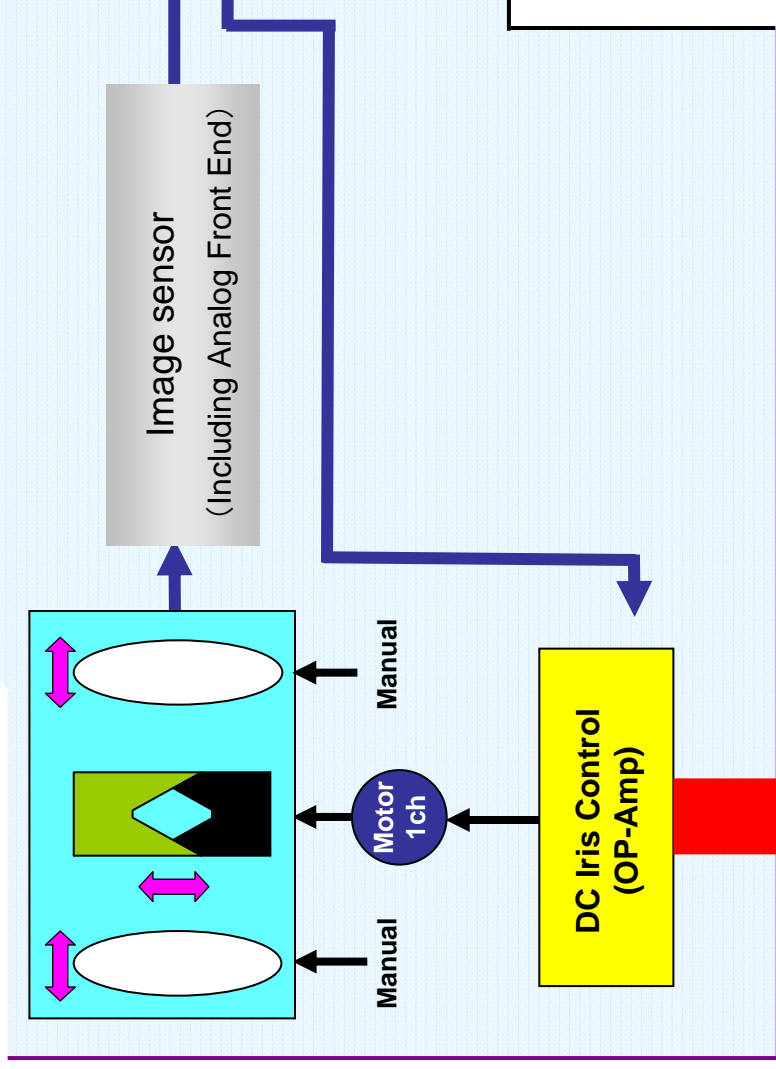

**Single chip solution
DC Iris Driver
AN41919A**

**Integration, II
Industry's first II**

Panasonic AN41919A Block Diagram

Contributes to Sets' Miniature Design

AN41919A

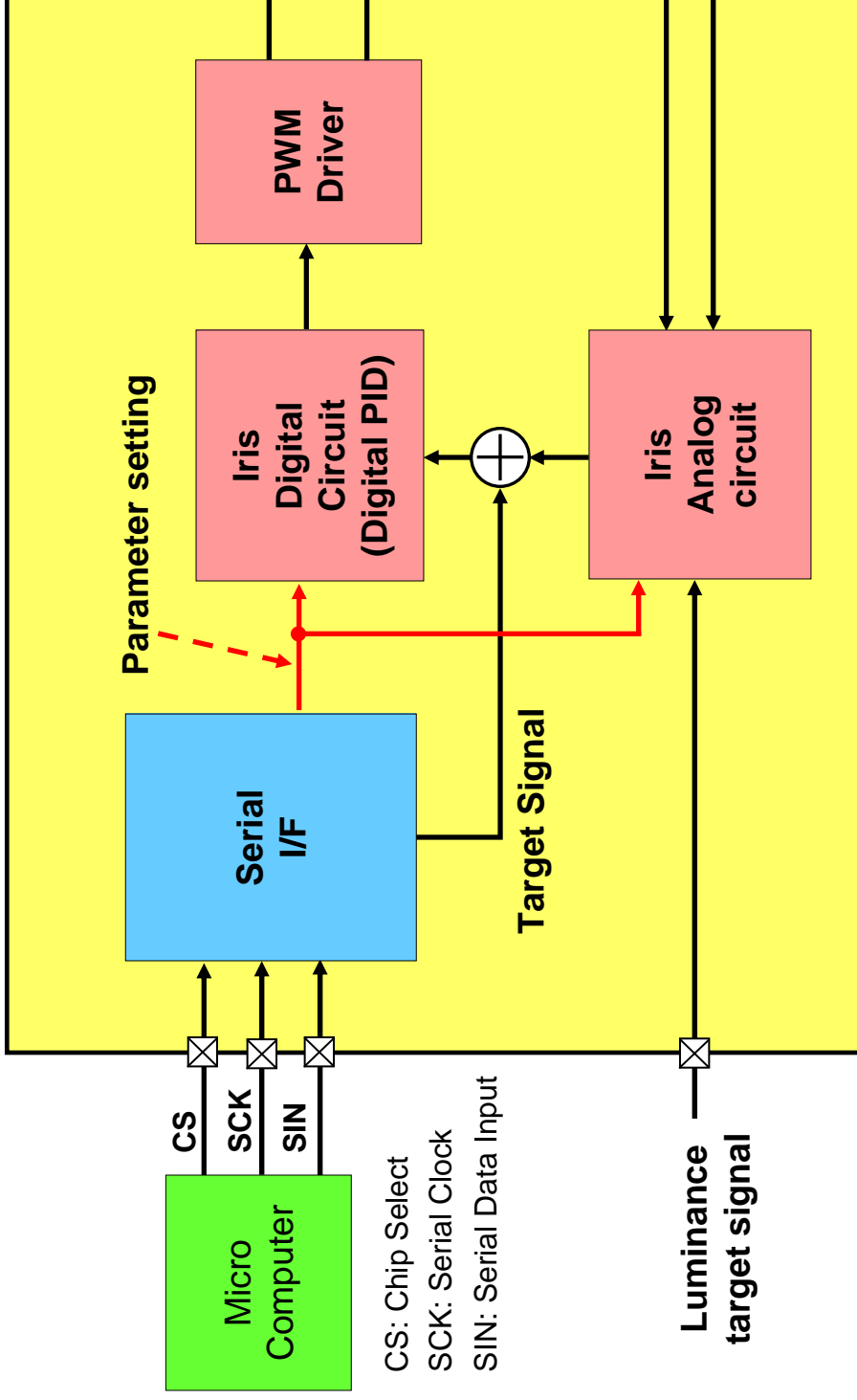

Single Chip Solution of DC Iris Function

Panasonic AN41919A Advantages

- **Reduced Design-In Time**
- **Low Power Consumption**

Reduced Design-In Time

Easy Adjustment of Iris Circuit

Existing System

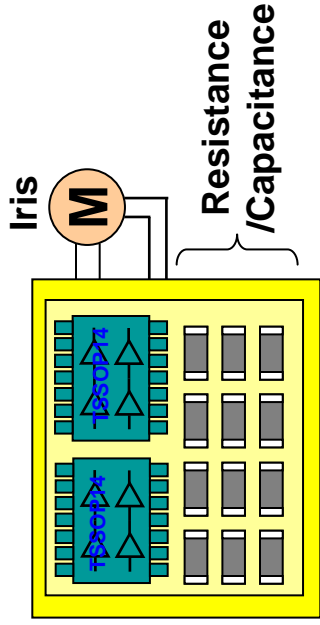

Inconvenient...

You needed to adjust Iris circuit when you start to design camera...

You needed to change external resistance and capacitance for Iris adjustment...

AN41919A

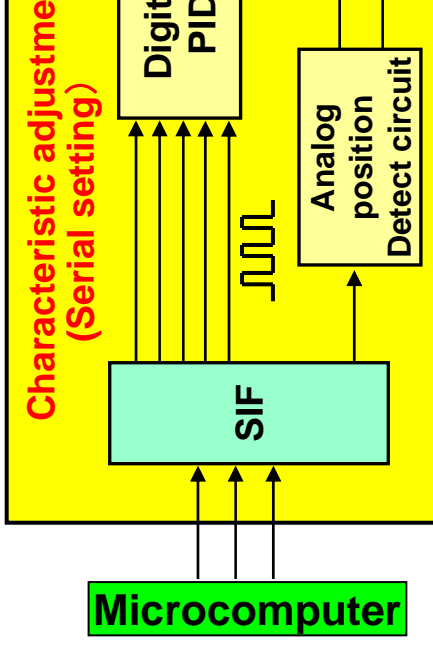

SIF: Serial Inter Face

PID: Proportion / integral calculus / calculus 3 elements digital

Improved !!

Software can arrange the circuit by software because of built-in digital

Low Power Consumption

50% Power Reduction by PWM Driving Sys

(Compared with Linear driving system)

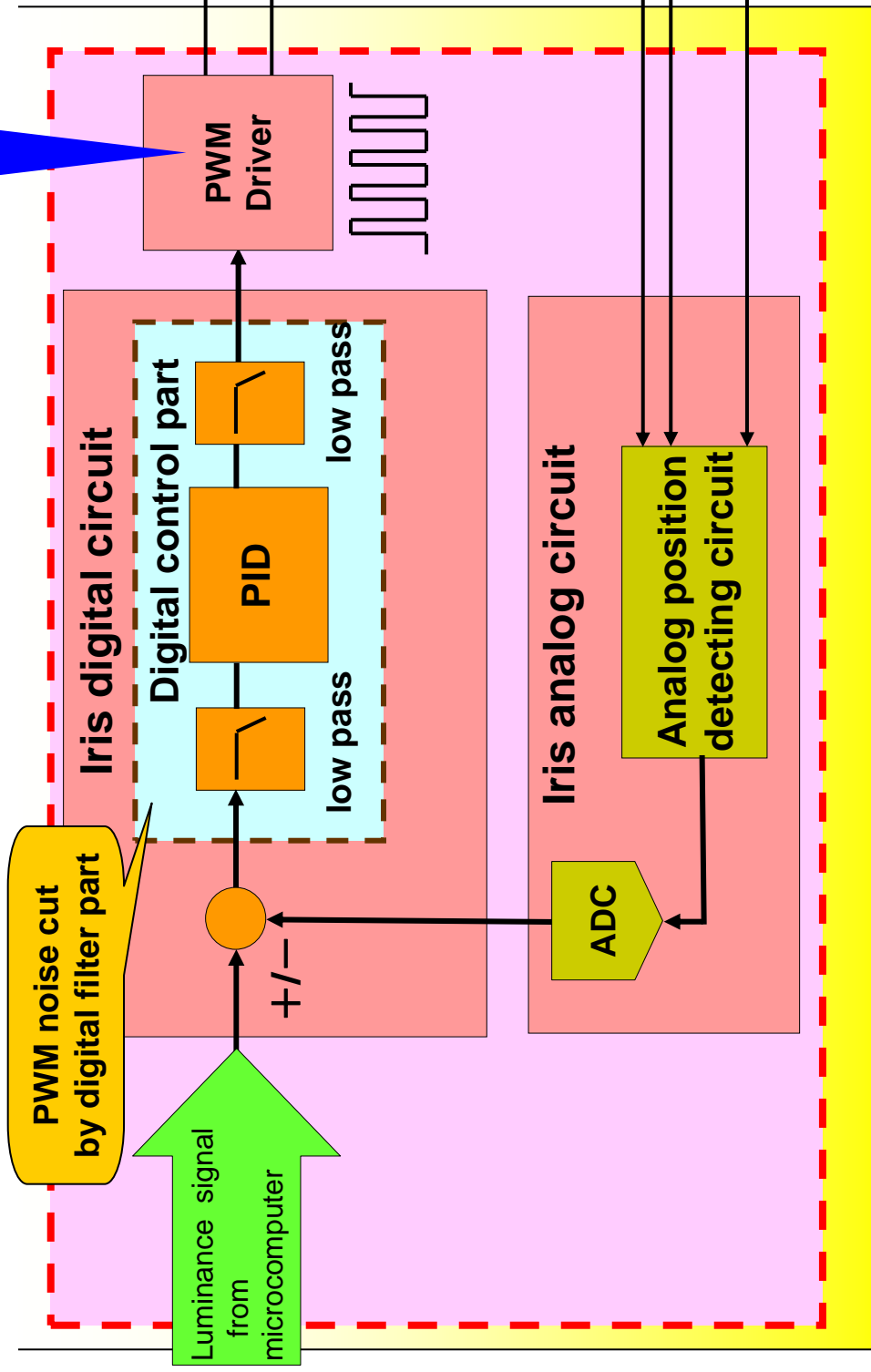

Panasonic AN41919A Application

Panasonic can prepare evaluation board and more specific applications

Overview

AN41919A is a iris control LSI for IP-camera and security-camera.

Features

- Built-in Iris controller
- Iris control by 4-line serial data communication

Applications

- IP-camera, Security-camera

Package

- 44 pin Plastic Quad Flat Non-leaded Package

Type

- Bi-COMS IC

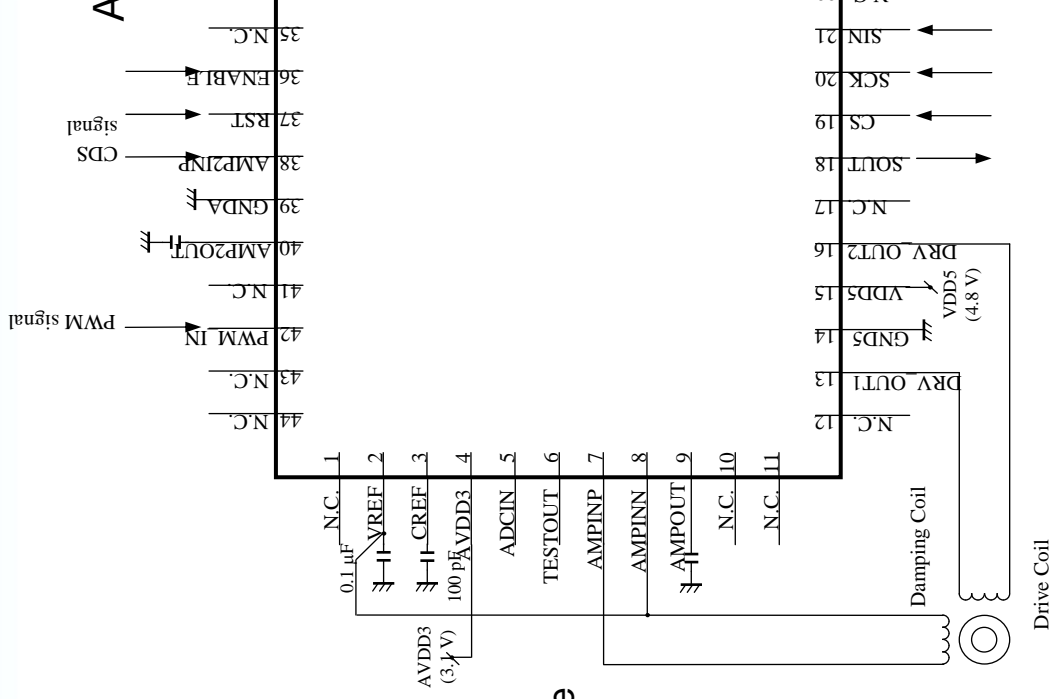
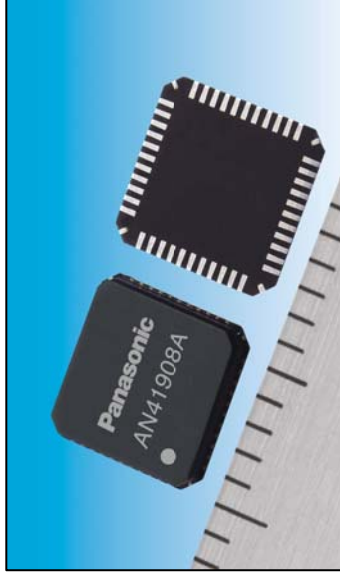

Evaluation Board

Connection for quick start-up

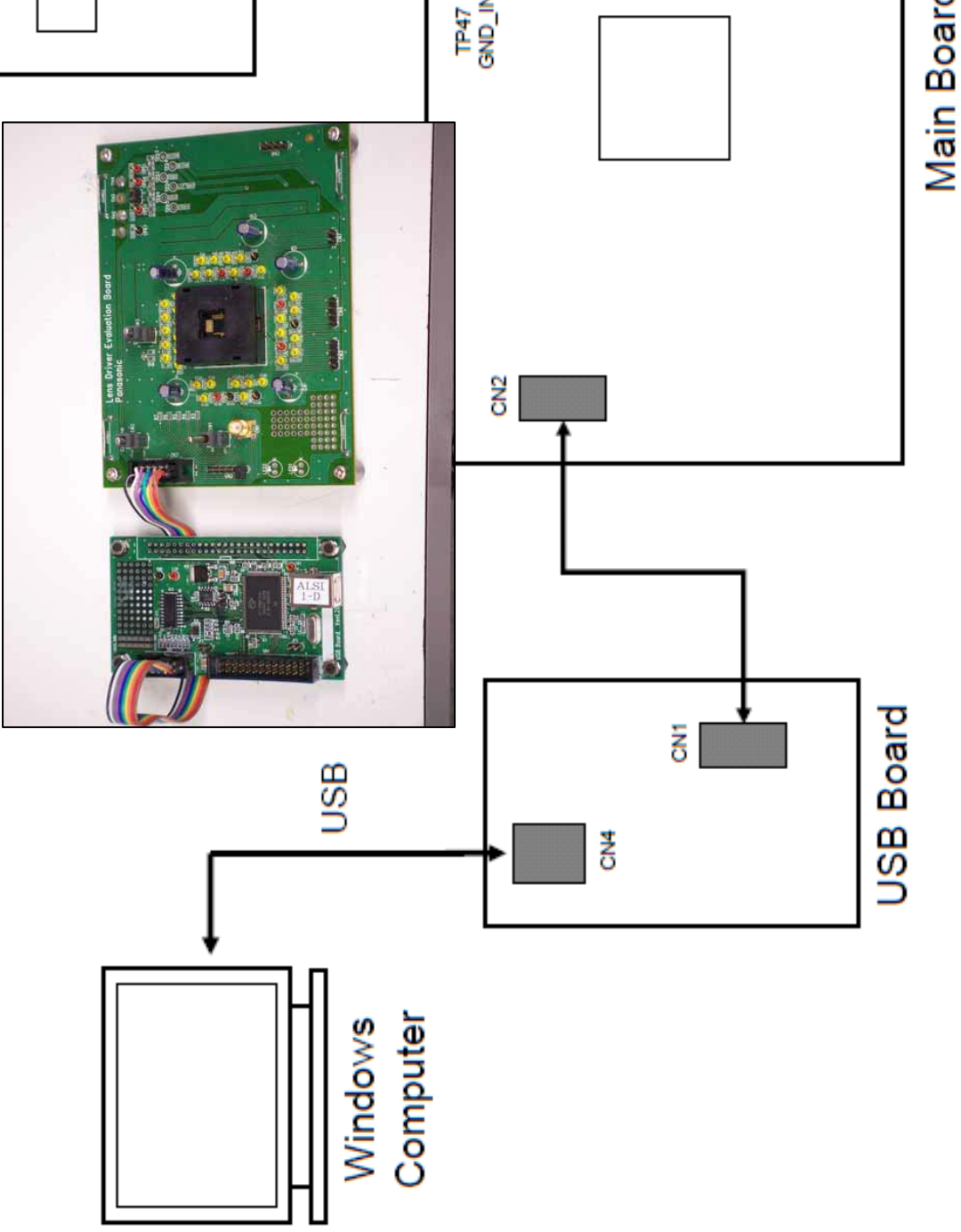



NEW! Special Function Motor Drivers

AN41908A Lens Driver

AN41919A DC Iris Driver

Looking for pricing, stock, or lifecycle information?

Click below to explore more details on WIN SOURCE:

 [View AN41908A-VB on WIN SOURCE](#)

 [Panasonic Information](#)

Optimize Your Supply Chain with WIN SOURCE Solutions

-  Global Sourcing Solution
-  Obsolete Management
-  Cost Control Management
-  Shortage Management
-  Alternative Solution
-  Excess Inventory Management