



**THE DATASHEET OF
BQ24780SRUYT**



Table of Contents

1 Features	1	7.4 Device Functional Modes	22
2 Applications	1	7.5 Programming	23
3 Description	1	7.6 Register Maps	25
4 Revision History	2	8 Application and Implementation	36
5 Pin Configuration and Functions	3	8.1 Application Information	36
6 Specifications	5	8.2 Typical Applications	36
6.1 Absolute Maximum Ratings	5	9 Power Supply Recommendations	44
6.2 ESD Ratings	5	10 Layout	44
6.3 Recommended Operating Conditions	5	10.1 Layout Guidelines	44
6.4 Thermal Information	6	10.2 Layout Examples	45
6.5 Electrical Characteristics	6	11 Device and Documentation Support	48
6.6 Timing Requirements	11	11.1 Receiving Notification of Documentation Updates	48
6.7 Typical Characteristics	13	11.2 Community Resources	48
7 Detailed Description	14	11.3 Trademarks	48
7.1 Overview	14	11.4 Electrostatic Discharge Caution	48
7.2 Functional Block Diagram	15	11.5 Glossary	48
7.3 Feature Description	16	12 Mechanical, Packaging, and Orderable Information	48

4 Revision History

Changes from Revision B (April 2015) to Revision C Page

- Full data sheet to product folder

1

Changes from Revision A (April 2015) to Revision B Page

- Changed the Description for pin 22 (GND) in the *Pin Functions* table
- Changed the Thermal Pad to PowerPAD in the *Pin Functions* table
- Changed 16X to 20X on the SRP and SRN pins of the *Functional Block Diagram*
- Changed C4 From: 0.01 μ F To: 0.1 μ F in [Figure 17](#)

4

4

15

36

Changes from Original (April 2015) to Revision A Page

- Changed $V_{(ACOC)}$ in the *Electrical Characteristics*, MIN From: 190% To: 180%, MAX From: 215% To: 220%
- Changed "ChargeOption() bit [0] = 0" To: REG0x12[0] in *Enable and Disable Charging*
- Changed "(REG0x12[1])" To: (REG0x12[0]=1) in *Enable and Disable Charging*
- Changed "REG0x12" To: "REG0x12[0]" in *Battery Charging*
- Changed Bit [10:9] in [Table 9](#) From: 11: 8 ms To: 11: 800 μ s
- Added sentence to Bit [7:6] in [Table 9](#) " If REG0x15() is programmed..."
- Changed text in Bit [5] of [Table 9](#) From: "write 0x3C[2] = 1." To: "write 0x3C[2] = 0."
- Deleted text from Bit [5] of [Table 9](#) "This function is not available in 1s battery."

9

17

17

22

30

30

30

30

5 Pin Configuration and Functions

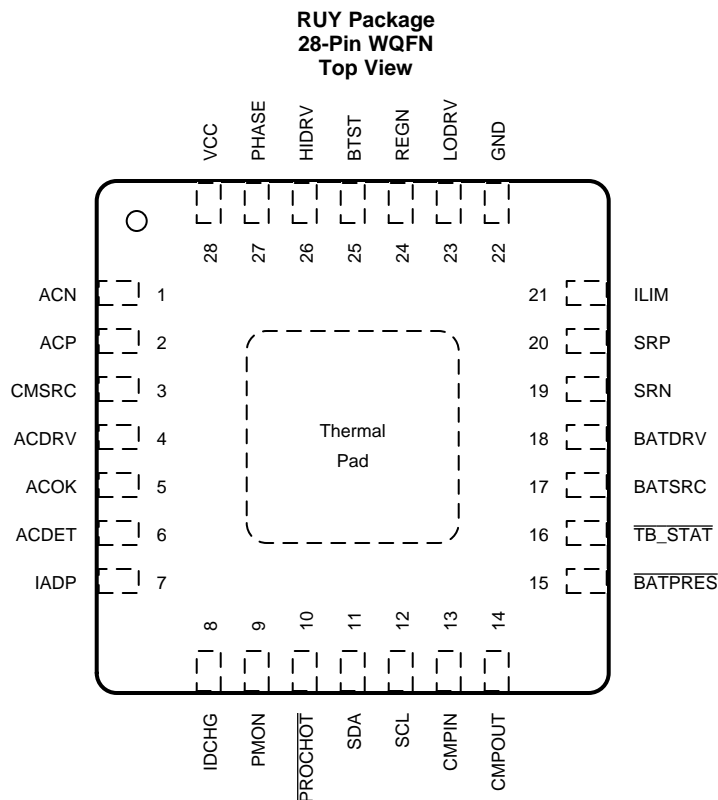

Pin Functions

PIN		DESCRIPTION
NAME	NUMBER	
ACN	1	Input current sense resistor negative input. Place an optional 0.01- μ F ceramic capacitor from ACN to GND for common-mode filtering. Place a 0.1- μ F ceramic capacitor from ACN to ACP to provide differential mode filtering.
ACP	2	Input current sense resistor positive input. Place a 0.1- μ F ceramic capacitor from ACP to GND for common-mode filtering. Place a 0.1- μ F ceramic capacitor from ACN to ACP to provide differential-mode filtering.
CMSRC	3	ACDRV charge pump source input. Place a 4-k Ω resistor from CMSRC to the common source of ACFET (Q1) and RBFET (Q2) to limit the inrush current on CMSRC pin.
ACDRV	4	Charge pump output to drive both adapter input N-channel MOSFET (ACFET) and reverse blocking N-channel MOSFET (RBFET). ACDRV voltage is 6 V above CMSRC when ACOK is HIGH. Place a 4-k Ω resistor from ACDRV to the gate of ACFET and RBFET limits the inrush current on ACDRV pin.
ACOK	5	Active HIGH AC adapter detection open drain output. It is pulled HIGH to external pullup supply rail by external pullup resistor when a valid adapter is present (ACDET above 2.4 V, VCC above UVLO but below ACOV and VCC above BAT). If any of the above conditions is not valid, ACOK is pulled LOW by internal MOSFET. Connect a 10-k Ω pullup resistor from ACOK to the pullup supply rail.
ACDET	6	Adapter detection input. Program adapter valid input threshold by connecting a resistor divider from adapter input to ACDET pin to GND pin. When ACDET pin is above 0.6 V and VCC is above UVLO, REGN LDO is present, ACOK comparator, input current buffer (IADP), discharge current buffer (IDCHG), independent comparator, and power monitor buffer (PMON) can be enabled with SMBus. When ACDET is above 2.4V, and VCC is above SRN but below ACOV, ACOK goes HIGH.
IADP	7	Buffered adapter current output. $V_{(IADP)} = 20$ or $40 \times (V_{(ACP)} - V_{(ACN)})$ The ratio of 20x and 40x is selectable with SMBus. Place 100-pF (or less) ceramic decoupling capacitor from IADP pin to GND. This pin can be floating if this output is not in use.
IDCHG	8	Buffered discharge current. $V_{(IDCHG)} = 8$ or $16 \times (V_{(SRN)} - V_{(SRP)})$ The ratio of 8x or 16x is selectable with SMBus. Place 100-pF (or less) ceramic decoupling capacitor from IDSCHG pin to GND. This pin can be floating if this output is not in use.

Pin Functions (continued)

PIN		DESCRIPTION
NAME	NUMBER	
PMON	9	Buffered total system power. The output current is proportional to the total power from the adapter and battery. The ratio is selectable through SMBus. Place a resistor from PMON pin to GND to generate PMON voltage. Place a 100-pF (or less) ceramic decoupling capacitor from PMON pin to GND. This pin can be floating if this output is not in use.
$\overline{\text{PROCHOT}}$	10	Active low, open-drain output of the processor hot indicator. The charger IC monitors events like adapter current, battery discharge current. After any event in the PROCHOT profile is triggered, a minimum 10-ms pulse is asserted.
SDA	11	SMBus open-drain data I/O. Connect to SMBus data line from the host controller or smart battery. SMBus communication starts when VCC is above UVLO. Connect a 10-k Ω pullup resistor according to SMBus specifications.
SCL	12	SMBus open-drain clock input. Connect to SMBus clock line from the host controller or smart battery. SMBus communication starts when VCC is above UVLO. Connect a 10-k Ω pullup resistor according to SMBus specifications.
CMPIN	13	Input of independent comparator. Internal reference, output polarity and deglitch time is selectable by SMBus. Place a resistor between CMPIN and CMPOUT to program hysteresis when the polarity is HIGH. If comparator is not in use, CMPIN is tied to ground, and CMPOUT is left floating.
CMPOUT	14	Open-drain output of independent comparator. Place 10-k Ω pullup resistor from CMPOUT to pullup supply rail. Comparator reference, output polarity and deglitch time is selectable by SMBus. If comparator is not in use, CMPIN is tied to ground, and CMPOUT is left floating.
$\overline{\text{BATPRES}}$	15	Active low battery present input signal. Low indicates battery present, high indicates battery absent. The device exits the LEARN function and turns on ACFET/RBFET within 100 μs if BATPRES pin is pulled high. Upon BATPRES from LOW to HIGH, battery charging and hybrid power boost mode are disabled. The host can enable charging and hybrid power boost mode by write to REG0x14() and REG0x15() when BATPRES is HIGH
$\overline{\text{TB_STAT}}$	16	Active low, open-drain output for hybrid power boost mode indication. It is pulled low when the IC is operating in boost mode. Otherwise, it is pulled high. Connect a 10-k Ω pullup resistor from $\overline{\text{TB_STAT}}$ pin to the pullup supply rail.
BATSRC	17	Connect to the source of N-channel BATFET. BATDRV voltage is 6 V above BATSRC to turn on BATFET.
BATDRV	18	Charge pump output to drive N-channel MOSFET between battery and system (BATFET). BATDRV voltage is 6 V above BATSRC to turn on BATFET and power system from battery. BATDRV is shorted to BATSRC to turn off BATFET. Place a 4-k Ω resistor from BATDRV to the gate of BATFET limits the inrush current on BATDRV pin.
SRN	19	Charge current sense resistor negative input. SRN pin is for battery voltage sensing as well. Connect SRN pin with a 0.1- μF ceramic capacitor to GND for common-mode filtering. Connect a 0.1- μF ceramic capacitor from SRP to SRN to provide differential mode filtering.
SRP	20	Charge current sense resistor positive input. Connect a 0.1- μF ceramic capacitor from SRP to SRN to provide differential mode filtering.
ILIM	21	Charge current and discharge current limit. $V_{\text{ILIM}} = 20 \times (V_{\text{SRP}} - V_{\text{SRN}})$ for charge current and $V_{\text{ILIM}} = 5 \times (V_{\text{SRN}} - V_{\text{SRP}})$ for discharge current. Program ILIM voltage by connecting a resistor divider from system reference 3.3-V rail to ILIM pin to GND pin. The lower of ILIM voltage and 0x14() (for charge) or 0x39 (for discharge) reference sets actual regulation limit. The minimum voltage on ILIM to enable charge or discharge current regulation is 120 mV.
GND	22	IC ground. On PCB layout, connect to analog ground plane, and only connect to power ground plan through pad underneath IC.
LODRV	23	Low-side power MOSFET driver output. Connect to low-side N-channel MOSFET gate.
REGN	24	6-V linear regulator output supplied from VCC. The LDO is active when ACDET above 0.6 V, VCC above UVLO. Connect a $\geq 2.2\text{-}\mu\text{F}$ 0603 ceramic capacitor from REGN to GND. The diode between REGN and BTST is integrated.
BTST	25	High-side power MOSFET driver power supply. Connect a 47-nF capacitor from BTST to PHASE. The diode between REGN and BTST is integrated inside the IC.
HIDRV	26	High-side power MOSFET driver output. Connect to the high side N-channel MOSFET gate.
PHASE	27	High-side power MOSFET driver source. Connect to the source of the high-side N-channel MOSFET.
VCC	28	Input supply from adapter or battery. Use 10- Ω resistor and 1- μF capacitor to ground as a low pass filter to limit inrush current. A diode OR is connected to VCC. It powers charger IC from input adapter and battery.
PowerPAD™		Exposed pad beneath the IC. Analog ground and power ground star-connected only at the PowerPAD plane. Always solder the PowerPAD to the board and have vias on the PowerPAD plane connecting to analog ground and power ground planes. It also serves as a thermal pad to dissipate the heat.

6 Specifications

6.1 Absolute Maximum Ratings

over operating free-air temperature range (unless otherwise noted)⁽¹⁾⁽²⁾

		MIN	MAX	UNIT
Voltage	SRN, SRP, ACN, ACP, CMSRC, VCC, BATSRC	-0.3	30	V
	PHASE	-2	30	
	ACDET, SDA, SCL, LODRV, REGN, IADP, IDCHG, PMON, ILIM, ACOK, CMPIN, CMPOUT, BATPRES, TB_STAT	-0.3	7	
	PROCHOT	-0.3	5.7	
	BTST, HIDRV, ACDRV, BATDRV	-0.3	36	
Differential voltage	BTST-PHASE, HIDRV-PHASE ACDRV-CMSRC, BATDRV-BATSRC	-0.3	7	V
Voltage	LODRV (2% duty cycle)	-4	7	V
	HIDRV (2% duty cycle)	-4	36	
Voltage	PHASE (2% duty cycle)	-4	30	V
Voltage	REGN (5ms)	-0.3	9	V
Maximum differential voltage	SRP-SRN, ACP-ACN	-0.5	+0.5	V
Junction temperature, T _J		-40	155	°C
Storage temperature, T _{stg}		-55	155	°C

- Stresses beyond those listed under absolute maximum ratings may cause permanent damage to the device. These are stress ratings only, and functional operation of the device at these or any other conditions beyond those indicated under recommended operating conditions is not implied. Exposure to absolute-maximum-rated conditions for extended periods may affect device reliability.
- All voltages are with respect to GND if not specified. Currents are positive into, negative out of the specified pin. Consult Packaging Section of the data book for thermal limitations and considerations of packages.

6.2 ESD Ratings

		VALUE	UNIT
V _(ESD)	Electrostatic discharge	Human body model (HBM), per ANSI/ESDA/JEDEC JS-001 ⁽¹⁾	V
		Charged device model (CDM), per JEDEC specification JESD22-C101 ⁽²⁾	

- JEDEC document JEP155 states that 500-V HBM allows safe manufacturing with a standard ESD control process.
- JEDEC document JEP157 states that 250-V CDM allows safe manufacturing with a standard ESD control process.

6.3 Recommended Operating Conditions

over operating free-air temperature range (unless otherwise noted)

		MIN	MAX	UNIT
Voltage	SRN, SRP, ACN, ACP, CMSRC, VCC, BATSRC	0	24	V
	PHASE	-2	24	
	ACDET, SDA, SCL, LODRV, REGN, IADP, IDCHG, PMON, ILIM, ACOK, CMPIN, CMPOUT, BATPRES, TB_STAT	0	6.5	
	PROCHOT	-0.3	5	
	BTST, HIDRV, ACDRV, BATDRV	0	30	
Maximum difference	SRP-SRN, ACP-ACN	-0.4	+0.4	V
Junction temperature, T _J		-20	125	°C
Operating free-air temperature, T _A		-40	85	

6.4 Thermal Information

THERMAL METRIC ⁽¹⁾		bq24780S	
		RUY (WQFN)	
		28 PINS	
Symbol	Description	Value	Unit
$R_{\theta JA}$	Junction-to-ambient thermal resistance	33.3	°C/W
$R_{\theta JCTop}$	Junction-to-case (top) thermal resistance	29.7	°C/W
$R_{\theta JB}$	Junction-to-board thermal resistance	6.5	°C/W
Ψ_{JT}	Junction-to-top characterization parameter	0.3	°C/W
Ψ_{JB}	Junction-to-board characterization parameter	6.5	°C/W
$R_{\theta JCbott}$	Junction-to-case (bottom) thermal resistance	1.3	°C/W

(1) For more information about traditional and new thermal metrics, see the IC Package Thermal Metrics application report, [SPRA953](#).

6.5 Electrical Characteristics

4.5 V ≤ V_{VCC} ≤ 24 V, −40°C ≤ T_J ≤ 125°C, typical values are at T_A = 25°C, with respect to GND (unless otherwise noted)

PARAMETER	TEST CONDITIONS	MIN	TYP	MAX	UNIT
OPERATING CONDITIONS					
V _{VCC(OP)}	VCC/ACP/ACN operating voltage	4.5		24	V
CHARGE VOLTAGE REGULATION					
V _{BAT(REG_RNG)}	Battery voltage	1.024		19.2	V
V _{BAT(REG_ACC)}	Charge voltage regulation accuracy	ChargeVoltage() = 0x41A0		16.8	V
		−10°C-85°C	−0.4%	0.4%	
		−40°C-125°C	−0.5%	0.5%	
		ChargeVoltage() = 0x3130		12.592	V
		−10°C-85°C	−0.4%	0.4%	
		−40°C-125°C	−0.5%	0.5%	
		ChargeVoltage() = 0x20D0		8.4	V
		−10°C-85°C	−0.4%	0.4%	
		−40°C-125°C	−0.6%	0.6%	
		ChargeVoltage() = 0x1060		4.192	V
		−10°C-85°C	−0.5%	0.8%	
		−40°C-125°C	−0.7%	0.8%	
CHARGE CURRENT REGULATION					
V _{IREG(CHG_RNG)}	Charge current regulation differential voltage	V _{IREG(CHG)} = V _{SRP} − V _{SRN}	0	81.28	mV
I _{CHRG(REG_ACC)}	Charge current regulation accuracy (SRN > 2.8 V)	ChargeCurrent() = 0x1000		4096	mA
		−2%	2%		
		ChargeCurrent() = 0x0800		2048	mA
		−3%	3%		
		ChargeCurrent() = 0x0200		512	mA
		−10%	10%		
		ChargeCurrent() = 0x0100		256	mA
		ChargeVoltage() = 0x20D0, 0x3031, 0x41A0	−16%	16%	
		ChargeVoltage() = 0x1060	−20%	20%	
		ChargeCurrent() = 0x00C0		192	mA
−20%	20%				
ChargeCurrent() = 0x0080		128	mA		
−30%	30%				
I _{LK(SRP-SRN)}	SRP and SRN leakage mismatch		−8	8	μA

Electrical Characteristics (continued)

4.5 V ≤ V_{VCC} ≤ 24 V, –40°C ≤ T_J ≤ 125°C, typical values are at T_A = 25°C, with respect to GND (unless otherwise noted)

PARAMETER		TEST CONDITIONS	MIN	TYP	MAX	UNIT
DISCHARGE CURRENT REGULATION						
V _(IREG_CHG_RNG)	Charge current regulation differential voltage	V _(IREG>IDISCHG) = V _{SRN} – V _{SRP}	0	322.56		mV
I _(DCHRG_REG_ACC)	Discharge current regulation accuracy	ChargeCurrent() = 0x2000		8192		mA
			–2%		2%	
		ChargeCurrent() = 0x1000		4096		mA
			–3%		3%	
		ChargeCurrent() = 0x0800		2048		mA
			–5%		5%	
		ChargeCurrent() = 0x0400		1024		mA
			–8%		8%	
		ChargeCurrent() = 0x0400		512		mA
			–10%		10%	
INPUT CURRENT REGULATION						
V _(IREG_DPM_RNG)	Input current regulation differential voltage	V _(IREG_DPM) = V _(ACP) – V _(ACN)	0	80.64		mV
I _(DPM_REG_ACC)	Input current regulation accuracy	InputCurrent() = 0x1000		4096		mA
			–2%		2%	
		InputCurrent() = 0x0800		2048		mA
			–3%		3%	
		InputCurrent() = 0x0400		1024		mA
			–5%		5%	
		InputCurrent() = 0x0200		512		mA
			–12%		12%	
I _{LGK(ACP-ARN)}	ACP and ACN leakage mismatch		–5		5	μA
INPUT CURRENT SENSE AMPLIFIER						
V _(IADP)	IADP output voltage		0	3.3		V
I _(IADP)	IADPT output current		0	1		mA
A _(IADP)	IADP sense amplifier gain	V _(IADP) / V _(ACP-ACN) , REG0x12[4] = 0		20		V/V
V _(IADP_ACC)	Current sense amplifier gain accuracy	V _(ACP-ACN) = 40 mV	–2%		2%	
		V _(ACP-ACN) = 20 mV	–4%		4%	
		V _(ACP-ACN) ≥ 10 mV	–7%		7%	
		V _(ACP-ACN) ≥ 5 mV	–20%		20%	
		V _(ACP-ACN) ≥ 2.5 mV	–30%		30%	
		V _(ACP-ACN) ≥ 1.5 mV	–40%		40%	
V _(IADP_CLAMP)	IADP clamp voltage		3	3.3		V
C _(IADP)	IADP output load capacitance	With 0 to 1mA load			100	pF
DISCHARGE CURRENT SENSE AMPLIFIER						
V _(IDCHG)	IDCHG output voltage		0	3.3		V
I _(IDCHG)	IDCHG output current		0	1		mA
A _(IDCHG)	Current sense amplifier gain	V _(IDCHG) /V _(SRN-SRP) , REG0x12[3] = 1		16		V/V
V _(IDCHG_ACC)	Current sense output accuracy	V _(SRN-SRP) = 40 mV	–5%		5%	
		V _(SRN-SRP) = 20 mV	–9%		9%	
		V _(SRN-SRP) = 10 mV	–17%		17%	
		V _(SRN-SRP) = 5 mV	–34%		34%	
V _(IDCHG_CLAMP)	IDCHG clamp voltage		3	3.3		V
C _(IDCHG)	IDCHG output load capacitance	With 0 to 1mA load			100	pF

Electrical Characteristics (continued)

4.5 V ≤ V_{VCC} ≤ 24 V, –40°C ≤ T_J ≤ 125°C, typical values are at T_A = 25°C, with respect to GND (unless otherwise noted)

PARAMETER		TEST CONDITIONS	MIN	TYP	MAX	UNIT
SYSTEM POWER SENSE AMPLIFIER						
V _(PMON)	PMON output voltage		0		3.3	V
I _(PMON)	PMON output current		0		160	μA
A _(PMON)	PMON system gain	V _(PMON) /(P _{IN} + P _{BAT} , REG0x3B[9] = 1		1		μA/W
V _{PMON_ACC}	PMON Gain Accuracy (REG0x3B[9]=1)	Adapter Only with System Power = 19.5V/45W	–4%		4%	
		Adapter Only with System Power = 12V/24W	–6%		6%	
		Adapter Only with System Power = 5V/9W	–10%		10%	
		Battery Only with System Power 11V/44W	–4.5%		4.5%	
		Battery Only with System Power 7.4V/29.8W	–7%		7%	
		Battery Only with System Power 3.7V/14.4W	–10%		10%	
V _{PMON_CLAMP}	PMON clamp voltage		3%		3.3%	V
C _{PMON}	Maximum output load capacitance	With 0 to 1 mA			100	pF
REGN REGULATOR						
V _(REGN_REG)	REGN regulator voltage	V _{VCC} > V _(UVLO) , V _(ACDET) > V _(wakeUp_RISE)	5.7	6	6.3	V
I _(REGN_LIM_Charging)	REGN current limit when in charging mode	V _(REGN) = 0 V, V _{VCC} > V _(UVLO) , in charging mode	80	100		mA
V _{LDO(DROPOUT)}	REGN output voltage in dropout	V _{VCC} = 5 V, I _{LOAD} = 20 mA	4.4	4.6	4.75	V
I _(REGN_LIM)	REGN current limit when not in charging	V _{REGN} = 0 V, V _{VCC} > V _(UVLO) , Not in charging mode	13			mA
I _(REGN_TSHUT)	REGN output under thermal shutdown	V _{REGN} = 5V	13	23		mA
C _(REGN)	REGN output capacitor	I _{LOAD} = 100 μA to 50 mA		2.2		μF
V_{CC} UNDER VOLTAGE LOCKOUT COMPARATOR						
V _{VCC(UVLO)}	Input undervoltage rising threshold	V _{CC} rising	2.4	2.6	2.8	V
V _{VCC(UVLO_HYS)}	Input undervoltage falling hysteresis			200		mV
QUIESCENT CURRENT						
I _{BAT}	Current with battery only, T _J = 0 to 85°C, I _{SRN} + I _{SRP} + I _{BATSRN} + I _{PHASE} + I _{VCC} + I _{ACP} + I _{ACN}	V _{BAT} = 16.8 V, V _{CC} disconnected from battery, REG0x12[15] = 1			5	μA
		V _{BAT} = 16.8 V, V _{CC} connected from battery, REG0x12[15] = 1		25	44	
		V _{BAT} = 16.8 V, V _{CC} connect to battery, BATFET on, REG0x12[15] = 0, REGN = 0 V, Comparator and PROCHOT enabled, PMON disabled, T _J = 0 to 85°C		700	800	
I _{AC}	Adapter current, I _{VCC} + I _{ACP} + I _{ACN} + I _{ACDRV} + I _{CMSRC}	V _(VCC_ULVO) < V _{VCC} < V _(ACOVF) , V _(ACDET) > 2.4 V, charge disabled		0.65	0.8	mA
		V _(VCC_ULVO) < V _{VCC} < V _(ACOVF) , V _(ACDET) > 2.4 V, charge enabled, no switching		1.6	3	
		V _(VCC_ULVO) < V _{VCC} < V _(ACOVF) , V _(ACDET) > 2.4 V, charge enabled, switching, MOSFET Qg 4nC		10		
ACOK COMPARATOR						
V _(ACOK_RISE)	ACOK rising threshold	V _{VCC} > V _(VCC_UVLO) , ACDET ramps up	2.375	2.4	2.425	V
V _(ACOK_FALL)	ACOK falling threshold	V _{VCC} > V _(VCC_UVLO) , ACDET ramps down	2.3	2.345	2.395	V
V _(WAKEUP_RISE)	WAKEUP detect rising threshold	V _{VCC} > V _(VCC_UVLO) , ACDET ramps up		0.57	0.8	V
V _(WAKEUP_FALL)	WAKEUP detect falling threshold	V _{VCC} > V _(VCC_UVLO) , ACDET ramps down	0.3	0.51		V
VCC to SRN COMPARATOR (VCC_SRN)						
V _(VCC-SRN_FALL)	VCC-SRN falling threshold to turn off ACDET	VCC ramps down to SRN	–20	60	140	mV
V _(VCC-SRN_RISE)	VCC-SRN rising threshold to turn on ACDET	VCC ramps up above SRN	170	260	360	mV
ACN to SRN COMPARATOR (ACN_SRN)						
V _(ACN-SRN_FALL)	ACN to BAT falling threshold VCC ramps up above SRN	ACN ramps down towards SRN	120	200	280	mV
V _(ACN-SRN_RISE)	ACN to BAT rising threshold to turn on BATFET	ACN ramps above SRN	220	290	360	mV

Electrical Characteristics (continued)

4.5 V ≤ V_{VCC} ≤ 24 V, –40°C ≤ T_J ≤ 125°C, typical values are at T_A = 25°C, with respect to GND (unless otherwise noted)

PARAMETER	TEST CONDITIONS	MIN	TYP	MAX	UNIT		
HIGH SIDE IFAULT COMPARATOR (IFault_HI)							
V _(ACN_PH_RISE)	ACN to PH rising threshold	reg0x37 bit [7] = 0		450	750	1200	mV
LOW SIDE IFAULT COMPARATOR (IFault_LOW)							
V _(IFault_LO_RISE)	PHASE to GND rising threshold	reg0x37 bit [6] = 1		180	250	340	mV
INPUT OVERVOLTAGE COMPARATOR (ACOVP)							
V _(ACOV)	VCC overvoltage rising threshold	VCC ramps up		24	26	28	V
V _(ACOV_HYS)	VCC overvoltage falling hysteresis	VCC ramps down		1			V
INPUT OVERCURRENT COMPARATOR (ACOC)							
V _(ACOC)	Rising threshold w.r.t. IC _{RIT} input current limit	REG0x37[9] = 1		180%	200%	220%	
V _(ACOC_CLAMP)	ACOC threshold	V _(ACP) – V _(ACN)		50	190		mV
BAT OVERVOLTAGE COMPARATOR (BAT_OVP)							
V _{OVP(RISE)}	Overvoltage rising threshold as percentage of V _{BAT(REG)}	SRN ramps up		103%	104%	106%	
V _{OVP(FALL)}	Overvoltage falling threshold as percentage of V _{BAT(REG)}	SRN ramps down		102%			
I _{OVP}	Discharge resistor on SRP	V _{SRN} > 6 V		6			mA
		V _{SRN} = 4.5 V		2.5			
CHARGE OVERCURRENT COMPARATOR (CHG_OCP)							
V _{OCP(limit)}	Cycle-by-cycle overcurrent limit, measured voltage between SRP and SRN	ChargeCurrent() = 0x0xxxH		54	60	66	mV
		ChargeCurrent() = 0x1000H – 0x17C0H		80	90	100	mV
		ChargeCurrent() = 0x1800H – 0x1FC0H		110	120	130	mV
CHARGE UNDERCURRENT COMPARATOR (CHG_UCP)							
V _{UCP(FALL)}	Cycle-by-cycle undercurrent falling threshold	SRP ramps down towards SRN		1	5	9	mV
LIGHT LOAD COMPARATOR (LIGHT_LOAD)							
V _{LL(FALL)}	Light load falling threshold	SRP ramps down towards SRN		1.25			mV
V _{LL(RISE_HYST)}	Light load rising hysteresis	SRP ramps above SRN		1.25			mV
BATTERY DEPLETION COMPARATOR (BAT_DEPL)							
V _{BAT(DEPL_FALL)}	Battery depletion falling threshold, as percentage of voltage regulation limit	REG0x3B[15:14] = 00		56%	60%	64%	
		REG0x3B[15:14] = 01		60%	64%	68%	
		REG0x3B[15:14] = 10		64%	68%	72%	
		REG0x3B[15:14] = 11		68%	72%	78%	
V _{BAT(DEPL_RISE_HYST)}	Battery depletion rising hysteresis	REG0x3B[15:14] = 00		225	305	400	mV
		REG0x3B[15:14] = 01		240	325	430	
		REG0x3B[15:14] = 10		255	345	450	
		REG0x3B[15:14] = 11		280	370	490	
V _{BAT(DEPL_RDEG)}	Battery depletion rising deglitch	Delay to turn on BATFET and turn off ACFET during LEARN cycle		600			ms
V _{BAT(DEPL_FDEG)}	Battery depletion falling deglitch	Delay to turn off BATFET and turn on ACFET during LEARN cycle		10			µs
BATTERY LOWV COMPARATOR (BAT_LOWV)							
V _{BAT(LV_FALL)}	Battery LOWV falling threshold	SRN ramps down		2.3	2.5	2.8	V
V _{BAT(LV_RHYST)}	Battery LOWV rising hysteresis	SRN ramps up		200			mV
I _{BAT(LV_RESET)}	Battery LOWV charge current limit	Measure across SRP and SRN		5			mV
THERMAL SHUTDOWN COMPARATOR (TSHUT)							
T _{SHUT}	Thermal shutdown rising temperature	Temperature ramps up		155			°C
T _{SHUT(HYS)}	Thermal shutdown hysteresis, falling	Temperature ramps down		20			°C
ILIM COMPARATOR							
V _{ILIM(FALL)}	ILIM as converter enable falling threshold	V _{ILIM} falling		60	75	90	mV
V _{ILIM(RISE)}	ILIM as converter enable rising threshold	V _{ILIM} rising		90	105	120	mV

Electrical Characteristics (continued)

4.5 V ≤ V_{VCC} ≤ 24 V, −40°C ≤ T_J ≤ 125°C, typical values are at T_A = 25°C, with respect to GND (unless otherwise noted)

PARAMETER		TEST CONDITIONS	MIN	TYP	MAX	UNIT
INDEPENDENT COMPARATOR						
V _(CMPPOS)	Comparator input offset		−4		4	mV
V _(CMPCM)	Comparator input common-mode		0		6.5	V
V _(CMPREF)	Comparator reference voltage (CMPIN falling)	REG0x3B[7] = 0	2.28	2.3	2.32	V
		REG0x3B[7] = 1	1.18	1.2	1.22	V
V _(CMPRISE)	Comparator reference hysteresis	REG0x3B[6] = 0		100		mV
PWM OSCILLATOR						
F _{SW}	PWM switching frequency	REG0x12[9:8] = 00	510	600	690	kHz
		REG0x12[9:8] = 01	680	800	920	
		REG0x12[9:8] = 10	850	1000	1150	
BATFET GATE DRIVER (BATDRV)						
I _{BAT(FET)}	BATDRV charge pump current limit	V _{BAT(DRV)} − V _{BAT(SRC)} = 5 V	40	60		μA
	Gate drive voltage on BATFET	V _{BAT(DRV)} − V _{BAT(SRC)} when V _(SRN) > V _{BAT(UVLO)}	5.5	6.1	6.8	V
R _{BAT(DRV_OFF)}	BATDRV turn-off resistance		5	6.2	7.4	kΩ
R _{BAT(DRV_LOAD)}	Minimum Load between gate and source		500			kΩ
ACFET GATE DRIVER (ACDRV)						
I _(ACFET)	ACDRV charge pump current limit	V _(ACDRV) − V _(CMSRC) = 5 V	40	60		μA
	Gate drive voltage on ACFET	V _(ACDRV) − V _(CMSRC) when V _{VCC} > V _(UVLO)	5.5	6.1	6.8	V
R _(ACDRV_OFF)	ACDRV turn-off resistance		5	6.2	7.4	kΩ
R _(ACDRV_LOAD)	Minimum load between gate and source		500			kΩ
PWM HIGH SIDE DRIVER (HIDRV)						
R _{DS(HI_ON)}	High-side driver (HSD) turn-on resistance	V _(BTST) − V _(PH) = 5.5 V		6	10	Ω
R _{DS(HI_OFF)}	High-side driver (HSD) turn-off Resistance	V _(BTST) − V _(PH) = 5.5 V		0.9	1.4	Ω
V _(BTST_REFRESH)	Bootstrap refresh comparator threshold voltage	V _(BTST) − V _(PH) when low side refresh pulse is requested	3.85	4.3	4.7	V
PWM LOW SIDE DRIVER (LODRV)						
R _{DS(LO_ON)}	Low-side driver (LSD) turn-on resistance			7.5	12	Ω
R _{DS(LO_OFF)}	Low-side driver (LSD) turn-off resistance			0.75	1.25	Ω
INTERNAL SOFT START						
I _{STEP}	Soft start step size			64		mA
t _{STEP}	Soft start step time			400		μs
PROCHOT						
V _(ICRIT)	ICRIT comparator threshold	REG0x3C[15:11] = 01001, as percentage of input current limit, InputCurrent() = 0x1000	147%	150%	153%	
V _(INOM)	INOM comparator threshold	as percentage of input current limit, InputCurrent()=0x0800	107%	110%	112%	
V _(IDCHG)	IDCHG comparator threshold	REG0x3D[15:11] = 10000, as voltage between SRN and SRP	160	163.84	167	mV
		REG0x3D[15:11] = 00100, as voltage between SRN and SRP	38	40.96	44	
V _(VSY)	VSY comparator threshold	REG0x3C[7:6] = 01	5.88	6	6.12	V
LOGIC INPUT (SDA, SCL, BATPRES)						
V _{(IN(LO))}	Input low threshold				0.8	V
V _{(IN(HI))}	Input high threshold		2.1			V
V _{(IN(LEAK))}	Input bias current	V = 7 V	−1			μA
LOGIC OUTPUT OPEN DRAIN (ACOK, SDA, CMPOUT, TB_STAT)						
V _{O(LO)}	Output saturation voltage	5-mA drain current			500	mV
V _{O(LEAK)}	Leakage current	V = 7 V	−1		1	μA
LOGIC OUTPUT OPEN DRAIN (PROCHOT)						
V _{O(LEAK_PROCHOT)}	Output saturation voltage	17-mA drain current			300	mV
	Leakage current	V = 5.5 V	−1		1	μA

6.6 Timing Requirements

$4.5\text{ V} \leq V_{\text{VCC}} \leq 24\text{ V}$, $-40^\circ\text{C} \leq T_{\text{J}} \leq 125^\circ\text{C}$, typical values are at $T_{\text{A}} = 25^\circ\text{C}$, with respect to GND (unless otherwise noted)

PARAMETER		MIN	TYP	MAX	UNIT		
ACOK COMPARATOR							
$t_{\text{ACOK_RISE_DEG}}$	ACOK rising deglitch to turn on ACFET; $V_{\text{ACDET}} > 2.4\text{V}$ ^[GBD]	$V_{\text{VCC}} > V_{\text{VCC_UVLO}}$, ACDET ramps up, 1st time or REG0x12[12] = 0		100	150	200	ms
		$V_{\text{VCC}} > V_{\text{VCC_UVLO}}$, ACDET ramps up, Not 1st time or REG0x12[12] = 1		0.9	1.3	1.7	s
$t_{\text{ACOK_FALL_DEG}}$	ACOK falling deglitch to turn off ACFET ^[GBD]	$V_{\text{VCC}} > V_{\text{VCC_UVLO}}$, ACDET ramps down			3	μs	
INPUT OVERCURRENT COMPARATOR (ACOC)							
$t_{\text{ACOC_DEG}}$	Deglitch time to latch off ACFET	9	12	15	ms		
SMBus TIMING CHARACTERISTICS							
t_{R}	SCLK/SDATA rise time			1	μs		
t_{F}	SCLK/SDATA fall time			300	ns		
$t_{\text{W(H)}}$	SCLK pulse width high	4		50	μs		
$t_{\text{W(L)}}$	SCLK pulse width low	4.7			μs		
$t_{\text{SU(STA)}}$	Setup time for start condition	4.7			μs		
$t_{\text{H(STA)}}$	Start condition hold time after which first clock pulse is generated	4			μs		
$t_{\text{SU(DAT)}}$	Data setup time	250			ns		
$t_{\text{H(DAT)}}$	Data hold time	300			ns		
$t_{\text{SU(STOP)}}$	Setup time for stop condition	4			μs		
$t_{\text{(BUF)}}$	Bus free time between start and stop condition	4.7			μs		
$F_{\text{S(CL)}}$	Clock frequency	10		100	kHz		
HOST COMMUNICATION FAILURE							
t_{timeout}	SMBus bus release timeout ⁽¹⁾	25		35	ms		
t_{BOOT}	Deglitch for watchdog reset signal	10			ms		
t_{WDI}	Watchdog timeout period, REG0x12 [14:13] = 01 ⁽²⁾	4	5	6	s		
t_{WDI}	Watchdog timeout period, REG0x12 [14:13] = 10 ⁽²⁾	70	88	105			
t_{WDI}	Watchdog timeout period, REG0x12 [14:13] = 11 ⁽²⁾ (default)	140	175	210			
PWM DRIVER TIMING							
$t_{\text{DEADTIME_RISE}}$	Driver dead time from low side to high side		20		ns		
$t_{\text{DEADTIME_FALL}}$	Driver dead time from high side to low side		20		ns		

- (1) Devices participating in a transfer timeout when any clock low exceeds the 25-ms minimum timeout period. Devices that have detected a timeout condition must reset the communication no later than the 35-ms maximum timeout period. Both a master and a slave must adhere to the maximum value specified because it incorporates the cumulative stretch limit for both a master (10 ms) and a slave (25 ms).
- (2) User can adjust threshold through SMBus ChargeOption() REG0x12.

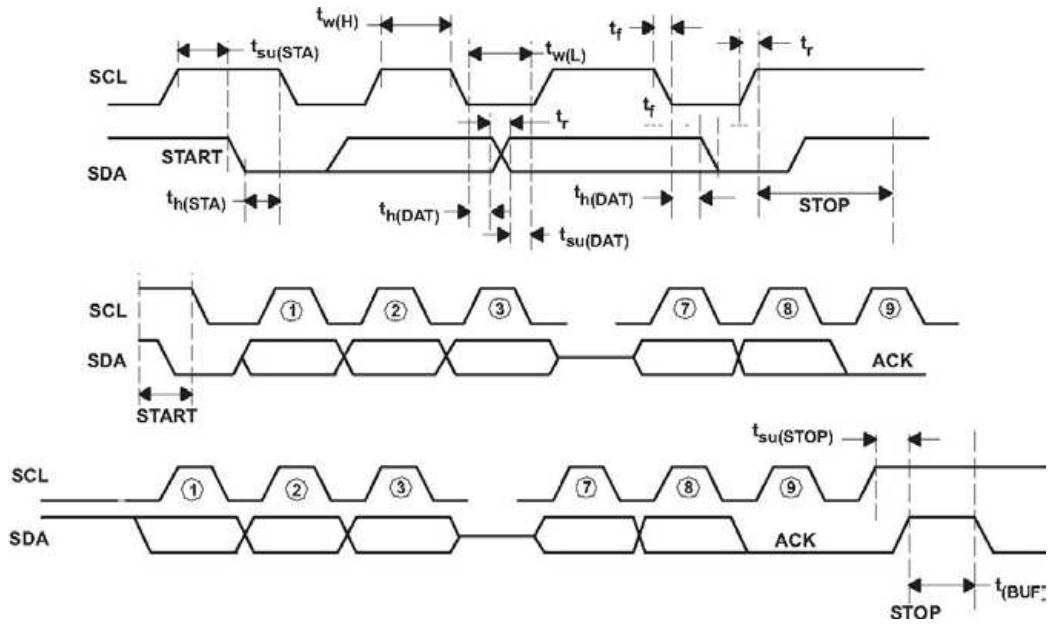
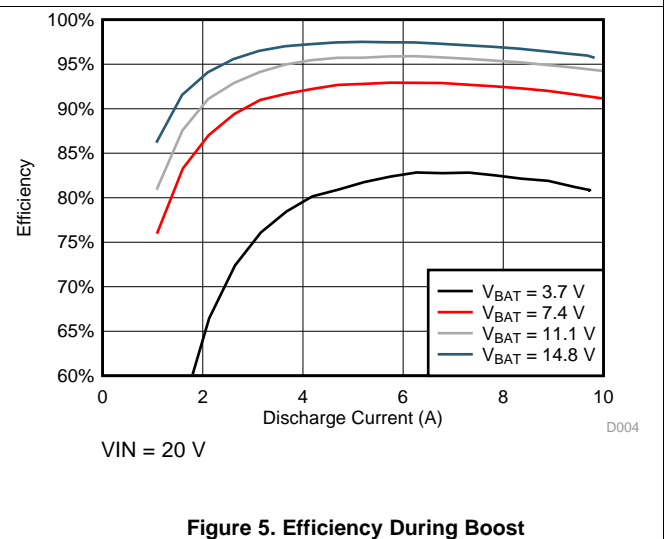
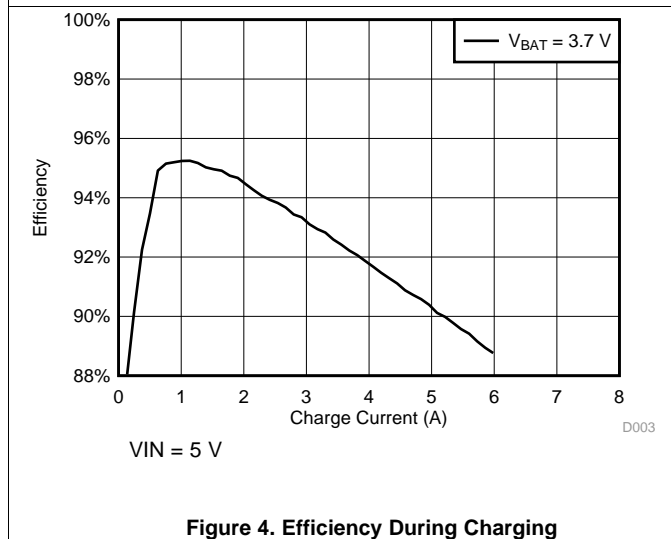
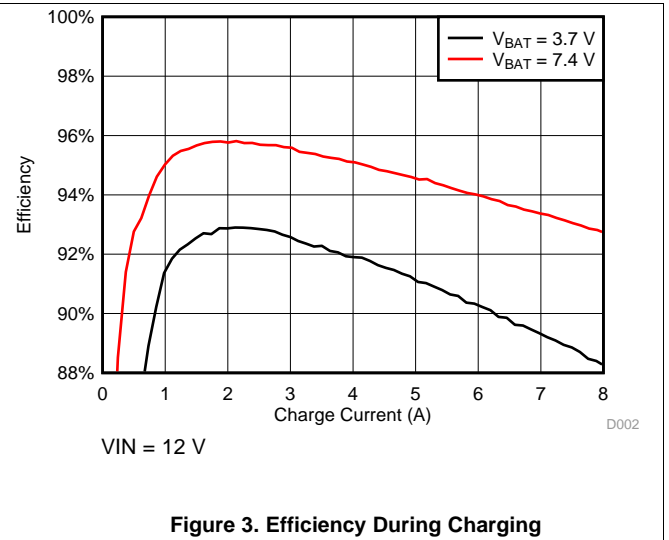
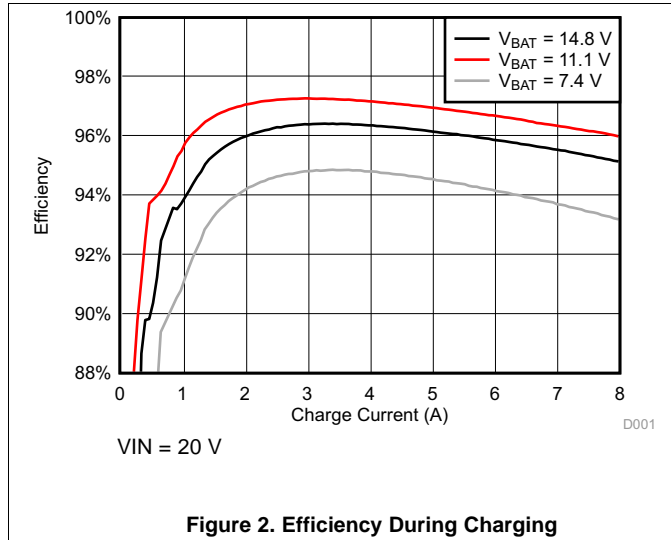

Figure 1. SMBus Communication Timing Waveforms

6.7 Typical Characteristics



7 Detailed Description

7.1 Overview

The bq24780S is a 1-4 cell battery charge controller with power selection for space-constrained, multi-chemistry portable applications such as notebook and detachable ultrabook. It supports wide input range of input sources from 4.5 V to 24 V, and 1-4 cell battery for a versatile solution.

The bq24780S supports automatic system power source selection with separate drivers for n-channel MOSFETS on the adapter side and battery side.

The bq24780S features Dynamic Power Management (DPM) to limit the input power and avoid AC adapter overloading. During battery charging, as the system power increases, the charging current will reduce to maintain total input current below adapter rating. If system power demand is temporarily exceeds adapter rating, the bq24780S supports hybrid power boost mode (previously called "turbo boost mode") to allow battery discharge energy to supplement system power. For details of hybrid power boost mode, refer to [Device Functional Modes](#) section.

The bq24780S closely monitors system power (P_{MON}), input current (I_{ADP}) and battery discharge current (I_{DCHG}) with highly accurate current sense amplifiers. If current is too high, adapter or battery is removed, a $\overline{\text{PROCHOT}}$ signal is asserted to CPU so that the CPU optimizes its performance to the power available to the system.

The SMBus controls input current, charge current and charge voltage registers with high resolution, high accuracy regulation limits. It also sets the $\overline{\text{PROCHOT}}$ timing and threshold profile to meet system requirements.

7.2 Functional Block Diagram

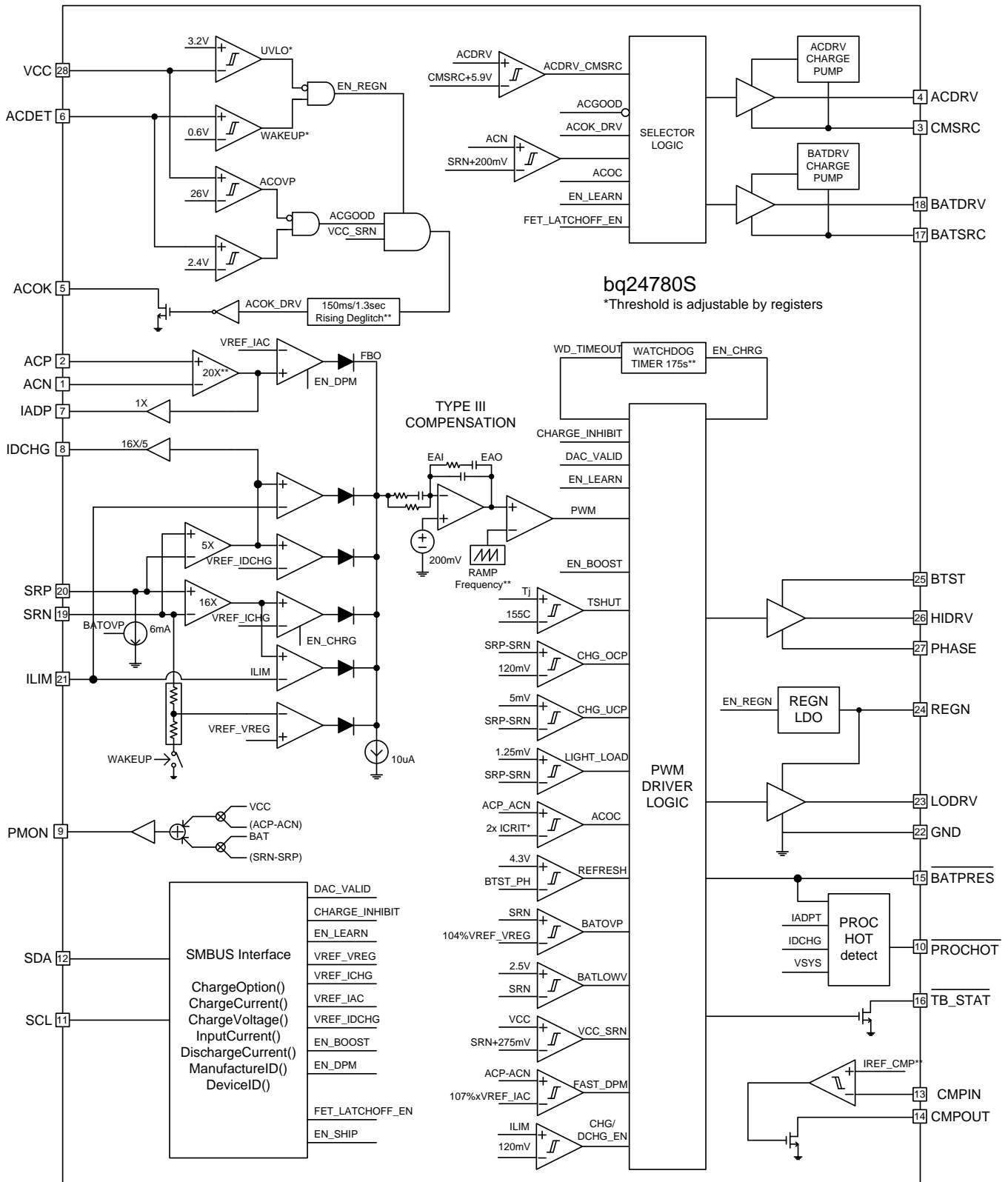

7.3 Feature Description

7.3.1 Device Power Up

The bq24780S gets power from adapter or battery. After VCC is above its UVLO threshold, the device wakes up and starts communication.

7.3.1.1 Battery Only

When VCC voltage is above UVLO, bq24780S powers up to turn on BATFET and starts SMBus communication. By default, bq24780S stays in low power mode ($REG0x12[15] = 1$) with lowest quiescent current. When $REG0x12[15]$ is set to 0, the device enters performance mode. User can enable IDCHG buffer, PMON, PROCHOT or comparator through SMBus. REGN LDO is enabled (except for IDCHG buffer) for accurate reference.

7.3.1.2 Adapter Detect and ACOK Output

An external resistor divider attenuates the adapter voltage before it goes to ACDET. The adapter detect threshold should typically be programmed to a value greater than the maximum battery voltage, but lower than the maximum allowed adapter voltage. When ACDET is above 0.6V, all bias circuits are enabled.

The open drain ACOK output can be pulled to external rail under the following conditions:

- $V_{VCC_UVLOZ} < V_{VCC} < ACOVP$
- $V_{ACDET} > 2.4\text{ V}$
- $V_{VCC} - V_{SRN} > V_{VCC_SRN_FALL} + V_{VCC_SRN_HYST}$

The $REG0x37[11]$ tracks the status of ACOK pin. ACOK deglitch time is 150ms at the first time adapter plug-in, and 1.3 sec at the following plug-ins after VCC or SRN is above its UVLOZ.

7.3.1.2.1 Adapter Overvoltage (ACOV)

When the VCC pin voltage is higher than 26 V, it is considered adapter over voltage. ACOK is pulled low, and charge is disabled. ACFET/RBFET are turned off to disconnect the high voltage adapter to system during ACOVP. BATFET is turned on if turn-on conditions are valid.

When VCC voltage falls below 24 V, it is considered as adapter voltage returns back to normal voltage. ACOK is pulled high by an external pullup resistor. BATFET is turned off and ACFET and RBFET is turned on to power the system from the adapter.

7.3.2 System Power Selection

The bq24780S device automatically switches adapter or battery power to system. An automatic break-before-make logic prevents shoot-through currents when the selectors switch.

The ACDRV drives a pair of common-source (CMSRC) N-channel power MOSFETs (ACFET and RBFET) between adapter and ACP. The ACFET separates adapter from system and battery, and provides a limited di/dt when plugging in adapter by controlling the ACFET turn-on time. Meanwhile, it protects the adapter when the system or battery is shorted. The RBFET provides negative input voltage protection and battery discharge protection when adapter is shorted to ground, and minimizes system power dissipation with its low $R_{DS(on)}$ compared to a Schottky diode.

When the adapter is not present, ACDRV is pulled to CMSRC to keep ACFET and RBFET off, disconnecting the adapter from the system. BATDRV stays at $V_{BATSRC} + 6\text{ V}$ to connect battery to system if all of the following conditions are valid:

- $V_{CC} > V_{UVLO}$
- $V_{ACN} < V_{SRN} + 200\text{ mV}$
- ACFET/RBFET off

After the adapter plugs in, the system power source switches from battery to adapter if all of the following conditions are valid:

- ACOK high
- Not in LEARN mode
- In LEARN mode and $V_{SRN} < \text{battery depletion threshold}$

Feature Description (continued)

The gate drive voltage on ACFET and RBFET is $V_{CMSRC} + 6$ V. If the ACFET/RBFET have been turned on for 20 ms, and the voltage across gate and source is still less than 5.7 V, ACFET and RBFET are turned off. After 1.3s delay, it resumes turning on ACFET and RBFET. If such a failure is detected seven times within 90 seconds, ACFET/RBFET are latched off and an adapter removal and system shut down is required to force $ACDET < 0.6$ V to reset the IC. After IC reset from latch off, ACFET/RBFET can be turned on again. After 90 seconds, the failure counter is reset to zero to prevent latch off.

To turn off ACFET/RBFET, one of the following conditions must be valid:

- In LEARN mode and V_{SRN} is above battery depletion threshold;
- ACOK low

To limit the adapter inrush current during ACFET turn-on, the Cgs and Cgd external capacitor of ACFET must be carefully selected following the guidelines below:

- Minimize total capacitance on system
- Cgs should be 40x or higher than Cgd to avoid ACFET false turn on during adapter hot plug-in
- Fully turn on ACFET within 20 ms, otherwise, charger IC will consider turn-on failure
- Check with MOSFET vendor on peak current rating
- Place 4-k Ω resistor in series with ACDRV, CMSRC, and BATDRV pin to limit inrush current.

7.3.3 Enable and Disable Charging

In charge mode, the following conditions have to be valid to start charge:

- Charge is enabled through SMBus (REG0x12[0], default is 0, charge enabled)
- ILIM pin voltage is higher than 120 mV
- All ChargeCurrent(), ChargeVoltage() and InputCurrent() registers have valid value programmed
- ACOK is valid (see [Device Power Up](#) for details)
- ACFET and RBFET turn on and gate voltage is high enough (see [System Power Selection](#) for details)
- V_{SRN} does not exceed BATOVP threshold
- IC temperature does not exceed TSHUT threshold
- Not in ACOC condition (see [Device Protections Features](#) for details)

One of the following conditions stops on-going charging:

- Charge is inhibited through SMBus(REG0x12[0]=1)
- ILIM pin voltage is lower than 60 mV
- One of three registers is set to 0 or out of range
- ACOK is pulled low (see [Device Power Up](#) for details)
- ACFET turns off
- V_{SRN} exceeds BATOVP threshold
- TSHUT IC temperature threshold is reached
- ACOC is detected (see [Device Protections Features](#) for details)
- Short circuit is detected (see [Inductor Short, MOSFET Short Protection](#) for details)
- Watchdog timer expires if watchdog timer is enabled (see [Charger Timeout](#) for details)

7.3.3.1 Automatic Internal Soft-Start Charger Current

Every time the charge is enabled, the charger automatically applies soft-start on charge current to avoid any overshoot or stress on the output capacitors or the power converter. The charge current starts at 128 mA, and the step size is 64 mA in CCM mode for a 10 m Ω current sensing resistor. Each step lasts around 400 μ s in CCM mode, till it reaches the programmed charge current limit. No external components are needed for this function.

During DCM mode, the soft start up current step size is larger and each step lasts for longer time period due to the intrinsic slow response of DCM mode.

Feature Description (continued)

7.3.4 Current and Power Monitor

7.3.4.1 High Accuracy Current Sense Amplifier (IADP and IDCHG)

As an industry standard, a high-accuracy current sense amplifier (CSA) is used to monitor the input current (IADP) and the discharge current (IDCHG). IADP voltage is 20X or 40X the differential voltage across ACP and ACN. IDCHG voltage is 8X or 16X the differential voltage across SRN and SRP. After VCC is above UVLO and ACDET is above 0.6 V, IADP output becomes valid. .

A maximum 100-pF capacitor is recommended to connect on the output for decoupling high-frequency noise. An additional RC filter is optional, if additional filtering is desired. Note that adding filtering also adds additional response delay. The CSA output voltage is clamped at 3.3 V. To lower the voltage on current monitoring, a resistor divider from CSA output to GND can be used and accuracy over temperature can still be achieved

7.3.4.2 High Accuracy Power Sense Amplifier (PMON)

The bq24780S device monitors total available power from adapter and battery together. The ratio of PMON voltage and total power K_{PMON} can be programmed in REG0x3B[9] with default 1 μ A/W. The bq24780S device allows input sense resistor 2x or 1/2x of charge sense resistor by setting REG0x3B[13:12] to 1.

$$I_{PMON} = K_{PMON} (V_{IN} \times I_{IN} - V_{BAT} \times I_{BAT}) \quad (I_{BAT} > 0 \text{ during charge; } I_{BAT} < 0 \text{ during discharge}) \quad (1)$$

A resistor is connected on the PMON pin to converter output current to output voltage. A maximum 100-pF capacitor is recommended to connect on the output for decoupling high-frequency noise. An additional RC filter is optional, if additional filtering is desired. Note that adding filtering also adds additional response delay. The PMON output voltage is clamped to 3.3 V.

7.3.5 Processor Hot Indication for CPU Throttling

When CPU is running turbo mode, the peak power may exceed total available power from adapter and battery. The adapter current and battery discharge overshoot, or system voltage drop indicates the system power may be too high. When the adapter or battery is removed, the remaining power source may not support the peak power in turbo mode. The processor hot function in bq24780S monitors these events, and $\overline{PROCHOT}$ pulse is asserted.

The $\overline{PROCHOT}$ triggering events include:

- ICRIT: adapter peak current
- INOM: adapter average current (110% of input current limit)
- IDCHG: battery discharge current
- VSYS: system voltage on SRN for 2s - 4s battery
- ACOK: upon adapter removal (ACOK pin HIGH to LOW)
- $\overline{BATPRES}$: upon battery removal ($\overline{BATPRES}$ pin LOW to HIGH)
- CMPOUT: Independent comparator output (CMPOUT pin HIGH to LOW)

The threshold of ICRIT, IDCHG or VSYS, and the deglitch time of ICRIT, INOM, IDCHG or CMPOUT are programmable through SMBus. Each triggering event can be individually enabled in REG0x3D[6:0].

Feature Description (continued)

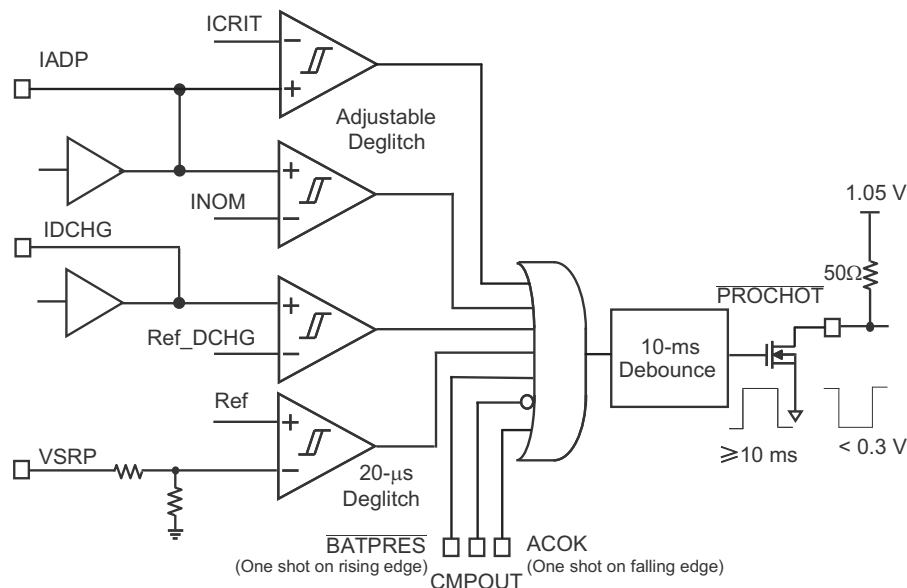

Figure 6. $\overline{\text{PROCHOT}}$ Profile

When any event in $\overline{\text{PROCHOT}}$ profile is triggered, $\overline{\text{PROCHOT}}$ is asserted low for minimum 10 ms (default REG0x3C[4:3]=10). At the end of the 10 ms, if the $\overline{\text{PROCHOT}}$ event is still active, the pulse gets extended.

During one cycle of $\overline{\text{PROCHOT}}$, all the triggering events are saved in status register REG0x3A[6:0] for easy test debug and system optimization.

7.3.6 Converter Operation

The synchronous buck PWM converter uses a fixed frequency voltage control scheme and internal type III compensation network. The LC output filter gives a characteristic resonant frequency:

$$f_o = \frac{1}{2\pi\sqrt{L_o C_o}} \tag{2}$$

The resonant frequency, f_o , is used to determine the compensation to ensure there is sufficient phase margin for the target bandwidth. The LC output filter should be selected to give a resonant frequency of 10- to 20-kHz nominal for the best performance. Suggested component value for a charge current of 800-kHz default switching frequency is shown in Table 1:

Table 1. Suggest Component Value for Charge Current of 800-kHz Default Switching Frequency

CHARGE CURRENT	2A	3A	4A	6A	8A
Output Inductor Lo (µH)	6.8 or 8.2	5.6 or 6.8	3.3 or 4.7	3.3	2.2
Output Capacitor Co (µF)	20	20	20	30	40
Sense Resistor (mΩ)	10	10	10	10	10

Ceramic capacitors show a DC-bias effect. This effect reduces the effective capacitance when a DC-bias voltage is applied across a ceramic capacitor, as on the output capacitor of a charger. The effect may lead to a significant capacitance drop, especially for high output voltages and small capacitor packages. See the manufacturer's data sheet about the performance with a DC bias voltage applied. It may be necessary to choose a higher voltage rating or nominal capacitance value to get the required value at the operating point.

7.3.6.1 Continuous Conduction Mode (CCM)

With sufficient charge current, the inductor current does not cross 0, which is defined as CCM. The controller starts a new cycle with ramp coming up from 200 mV. As long as EAO voltage is above the ramp voltage, the high-side MOSFET (HSFET) stays on. When the ramp voltage exceeds EAO voltage, HSFET turns off and low-side MOSFET (LSFET) turns on. At the end of the cycle, ramp gets reset and LSFET turns off, ready for the next cycle. There is always break-before-make logic during transition to prevent cross-conduction and shoot-through. During the dead time when both MOSFETs are off, the body-diode of the low-side power MOSFET conducts the inductor current.

During CCM, the inductor current always flows and creates a fixed two-pole system. Having the LSFET turn-on keeps the power dissipation low and allows safe charging at high currents.

7.3.6.2 Discontinuous Conduction Mode (DCM)

During the HSFET off time when LSFET is on, the inductor current decreases. If the current goes to 0, the converter enters DCM. Every cycle, when the voltage across SRP and SRN falls below 5 mV (0.5 A on 10 m Ω), the undercurrent-protection comparator (UCP) turns off LSFET to avoid negative inductor current, which may boost the system through the body diode of HSFET.

During DCM the loop response automatically changes. It changes to a single-pole system and the pole is proportional to the load current.

7.3.6.3 Non-Sync Mode and Light Load Comparator

As the charge current is below 125 mA (on 10-m Ω sense resistor), the light load comparator keeps LSFET off. The converter enters non-sync mode. With LSFET, body diode blocks negative current in the inductor so that no current flows back to the input. As charge current rises above 250 mA, LSFET turns on again.

7.3.6.4 EMI Switching Frequency Adjust

The charger switching frequency can be adjusted 600 kHz or 1 MHz to solve EMI issues through SMBus command REG0x12[9:8].

7.3.7 Battery LEARN Cycle

A battery LEARN cycle can be activated through the REG0x12[5]. When LEARN is enabled, the system receives power from the battery instead of the adapter turning off ACFET/RBFET and turning on BATFET. The LEARN function allows the battery to discharge in order to calibrate the battery gas gauge over a complete discharge and charge cycle. The controller automatically exits the LEARN cycle when the battery voltage is below the battery depletion threshold. The system switches back to adapter input by turning off BATFET and turning on ACFET/RBFET. After the LEARN cycle, REG0x12[5] is automatically reset to 0.

When the battery is removed during LEARN mode, $\overline{\text{BATPRES}}$ rises from low to high and the device exits LEARN mode. ACFET/RBFET quickly turns on in 100 μs to prevent the system from crashing. The turn-on triggered by BATPRES is faster than that triggered by battery depletion comparator.

7.3.8 Charger Timeout

The bq24780S device includes a watchdog timer to terminate charging or hybrid power boost mode if the charger does not receive a write ChargeVoltage() or write ChargeCurrent() command within 175 s (adjustable through 0x12[14:13] command).

If a watchdog timeout occurs, all register values keep unchanged, but converter is suspended. A write to ChargeVoltage(), or ChargeCurrent(), or change REG0x12[14:13] resets watchdog timer and resumes converter for charging or hybrid power boost mode. The watchdog timer can be disabled, or set to 5, 88, or 175 s through SMBus command REG0x12[14:13]).

7.3.9 Device Protections Features

7.3.9.1 Input Overcurrent Protection (ACOC)

The bq24780S device cannot maintain the input current level if the charge current has been already reduced to 0. When the input current exceeds 1.25x or 2x of ICRIT set point (with 12-ms blank-out time), ACFET/RBFET is latched off and an adapter removal is required to force ACDET < 0.6 V to reset IC. After IC reset from latch off, ACFET/RBFET can be turned on again.

The ACOG function threshold can be set to 1.25x or 2x of ICRIT (REG37[9]) current or disabled through SMBus command (REG0x37[10]).

7.3.9.2 Charge Overcurrent Protection (CHGOCP)

The bq24780S device has cycle-by-cycle peak overcurrent protection. It monitors the voltage across SRP and SRN, and prevents the current from exceeding the threshold based on the charge current set point. The high-side gate drive turns off for the rest of the cycle when over current is detected, and resumes when the next cycle starts.

The charge OCP threshold is automatically set to 6, 9, and 12 A on a 10-mΩ current sensing resistor based on charge current register value. This prevents the threshold from being too high, which is not safe, or too low, which can be triggered in typical operation. Select proper inductance to prevent OCP triggering in typical operation due to high inductor current ripple.

7.3.9.3 Battery Overvoltage Protection (BATOVP)

The bq24780S device does not allow the high-side and low-side MOSFET to turn-on when the battery voltage at SRN exceeds 104% of the regulation voltage set point. If BATOVP lasts over 30 ms, charger is completely disabled. This allows a quick response to an overvoltage condition – such as when the load is removed or the battery is disconnected. A 6-mA current sink from SRP to GND is only on during BATOVP and allows discharging the stored output inductor energy that is transferred to the output capacitors.

7.3.9.4 Battery Short

When battery voltage on SRN falls below 2.5 V, the converter resets for 1 ms and resumes charge if all the enable conditions in the [Enable and Disable Charging](#) section are satisfied. This prevents overshoot current in the inductor, which can saturate the inductor and may damage the MOSFET. The charge current is limited to 0.5 A on 10-mΩ current sensing resistor when BATLOWV condition persists and LSFET keeps off. The LSFET turns on only for a refreshing pulse to charge BTST capacitor.

7.3.9.5 Thermal Shutdown Protection (TSHUT)

The WQFN package has low thermal impedance, which provides good thermal conduction from the silicon to the ambient, to keep junction temperatures low. As an added level of protection, the charger converter turns off for self-protection whenever the junction temperature exceeds the 155°C. The charger stays off until the junction temperature falls below 135°C. During thermal shutdown, the REGN LDO current limit is reduced to 14 mA. Once the temperature falls below 135°C, charge can be resumed with soft start.

7.3.9.6 Inductor Short, MOSFET Short Protection

The bq24780S device has a unique short circuit protection feature. Its cycle-by-cycle current monitoring feature is achieved through monitoring the voltage drop across RDS(on) of the MOSFETs after a certain amount of blanking time. In case of a MOSFET short or inductor short circuit, the overcurrent condition is sensed by two comparators and two counters are triggered. After seven short circuit events, the charger is latched off and ACFET and RBFET are turned off to disconnect the adapter from the system. BATFET is turned on to connect the battery pack to the system. To reset the charger from latch-off status, the IC VCC pin must be pulled below UVLO or the ACDET pin must be pulled below 0.6 V. This can be achieved by removing the adapter and shutting down the operation system. The low-side MOSFET Vds monitor circuit is enabled by REG0x37[7], and the threshold is 750 mV. The high-side MOSFET Vds monitor circuit is enabled by REG0x37[6], and the threshold is 250 mV. During boost function, the low-side MOSFET short circuit protection threshold is used for cycle-by-cycle current limiting, charger does not latch up.

Due to the amount of blanking time to prevent noise when MOSFET just turns on, the cycle-by-cycle charge overcurrent protection may detect high current and turn off MOSFET first before the short circuit protection circuit can detect short condition because the blanking time has not finished. In such a case, the charger may not be able to detect a short circuit and the counter may not be able to count to seven then latch off. Instead the charger may continuously keep switching with very narrow duty cycle to limit the cycle-by-cycle current peak value. However, the charger should still be safe and does not cause failure because the duty cycle is limited to a very short time and the MOSFET should still be inside the safety operation area. During a soft start period, it may take a long time instead of just seven switching cycles to detect short circuit based on the same blanking time reason.

7.4 Device Functional Modes

7.4.1 Battery Charging

The bq24780S charges 1-4 cell battery in constant current (CC), and constant voltage (CV) mode. The host programs battery voltage in REG0x15(). According to battery voltage, the host programs appropriate charge current in REG0x14(). When battery is full or battery is not in good condition to charge, host terminates charge by setting REG0x12[0] to 1, or setting either ChargeVoltage() or ChargeCurrent() to zero.

See the [Feature Description](#) section for details on charge enable conditions and register programming.

7.4.2 Hybrid Power Boost Mode

The bq24780S device supports the hybrid power boost mode by allowing battery discharge energy to system when system power demand is temporarily higher than adapter maximum power level so the adapter does not crash. After device powers up, the REG0x37[2] is 0 to disable hybrid power boost mode. To enable hybrid power boost mode, host writes 1 to REG0x37[2]. The TB_STAT pin and REG0x37[1] indicate if the device is in hybrid power boost mode.

To support hybrid power boost mode, input current must be set higher than 1536 mA for 10 mΩ input current sensing resistor. When input current is higher than 107% of input current limit in REG0x3F(), charger IC allows battery discharge and charger converter changes from buck converter to boost converter. During hybrid power boost mode the adapter current is regulated at input current limit level so that adapter will not crash. The battery discharge current depends on system current requirement and adapter current limit. The watchdog timer can be enabled to prevent converter running at hybrid power boost mode for too long.

7.4.2.1 Battery Discharge Current Regulation in Hybrid Power Boost Mode

To keep the discharge current below battery OCP rating during boost mode, the bq24780S device supports discharge current regulation. After device powers up, the REG0x37[15] is 0 to disable discharge current regulation. To enable discharge current regulation, host writes 1 to REG0x37[15].

Once the battery discharge current is limited, the input current goes up to meet the system current requirement. The user can assert $\overline{\text{PROCHOT}}$ to detect input current increase (ICRIT or INOM), and request CPU throttling to lower the system power.

7.5 Programming

7.5.1 SMBus Interface

The bq24780S device operates as a slave, receiving control inputs from the embedded controller host through the SMBus interface. The bq24780S device uses a simplified subset of the commands documented in *System Management Bus Specification V1.1*, which can be downloaded from www.smbus.org. The bq24780S device uses the SMBus read-word and write-word protocols (shown in [Table 2](#) and [Table 3](#)) to communicate with the smart battery. The bq24780S device performs only as a SMBus slave device with address 0b00010010 (0x12H) and does not initiate communication on the bus. In addition, the device has two identification registers, a 16-bit device ID register (0xFFH) and a 16-bit manufacturer ID register (0xFEH).

SMBus communication starts when VCC is above UVLO.

The data (SDA) and clock (SCL) pins have Schmitt-trigger inputs that can accommodate slow edges. Choose pullup resistors (10 kΩ) for SDA and SCL to achieve rise times according to the SMBus specifications. Communication starts when the master signals a start condition, which is a high-to-low transition on SDA, while SCL is high. When the master has finished communicating, the master issues a stop condition, which is a low-to-high transition on SDA, while SCL is high. The bus is then free for another transmission. [Figure 7](#) and [Figure 8](#) show the timing diagram for signals on the SMBus interface. The address byte, command byte, and data bytes are transmitted between the start and stop conditions. The SDA state changes only while SCL is low, except for the start and stop conditions. Data is transmitted in 8-bit bytes and is sampled on the rising edge of SCL. Nine clock cycles are required to transfer each byte in or out of the bq24780S device because either the master or the slave acknowledges the receipt of the correct byte during the ninth clock cycle. The bq24780S supports the charger commands listed in [Table 2](#).

7.5.1.1 SMBus Write-Word and Read-Word Protocols

Table 2. Write-Word Format

S ⁽¹⁾⁽²⁾	SLAVE ADDRESS ⁽¹⁾	W ⁽¹⁾⁽³⁾	ACK ⁽⁴⁾⁽⁵⁾	COMMAND BYTE ⁽¹⁾	ACK ⁽⁴⁾⁽⁵⁾	LOW DATA BYTE ⁽¹⁾	ACK ⁽⁴⁾⁽⁵⁾	HIGH DATA BYTE ⁽¹⁾	ACK ⁽⁴⁾⁽⁵⁾	P ⁽¹⁾⁽⁶⁾
	7 bits	1b	1b	8 bits	1b	8 bits	1b	8 bits	1b	
	MSB LSB	0	0	MSB LSB	0	MSB LSB	0	MSB LSB	0	

- (1) Master to slave
- (2) S = Start condition or repeated start condition
- (3) W = Write bit (logic-low)
- (4) Slave to master (shaded gray)
- (5) ACK = Acknowledge (logic-low)
- (6) P = Stop condition

Table 3. Read-Word Format

S ⁽¹⁾⁽²⁾	SLAVE ADDRESS ⁽¹⁾	W ⁽¹⁾⁽³⁾	ACK ⁽⁴⁾⁽⁵⁾	COMMAND BYTE ⁽¹⁾	ACK ⁽⁴⁾⁽⁵⁾	S ⁽¹⁾⁽²⁾	SLAVE ADDRESS ⁽¹⁾	R ⁽¹⁾⁽⁶⁾	ACK ⁽⁴⁾⁽⁵⁾	LOW DATA BYTE ⁽⁴⁾	ACK ⁽¹⁾⁽⁵⁾	HIGH DATA BYTE ⁽⁴⁾	NACK ⁽¹⁾⁽⁷⁾	P ⁽¹⁾⁽⁸⁾
	7 bits	1b	1b	8 bits	1b		7 bits	1b	1b	8 bits	1b	8 bits	1b	
	MSB LSB	0	0	MSB LSB	0		MSB LSB	1	0	MSB LSB	0	MSB LSB	1	

- (1) Master to slave
- (2) S = Start condition or repeated start condition
- (3) W = Write bit (logic-low)
- (4) Slave to master (shaded gray)
- (5) ACK = Acknowledge (logic-low)
- (6) R = Read bit (logic-high)
- (7) NACK = Not acknowledge (logic-high)
- (8) P = Stop condition

7.5.1.2 Timing Diagrams

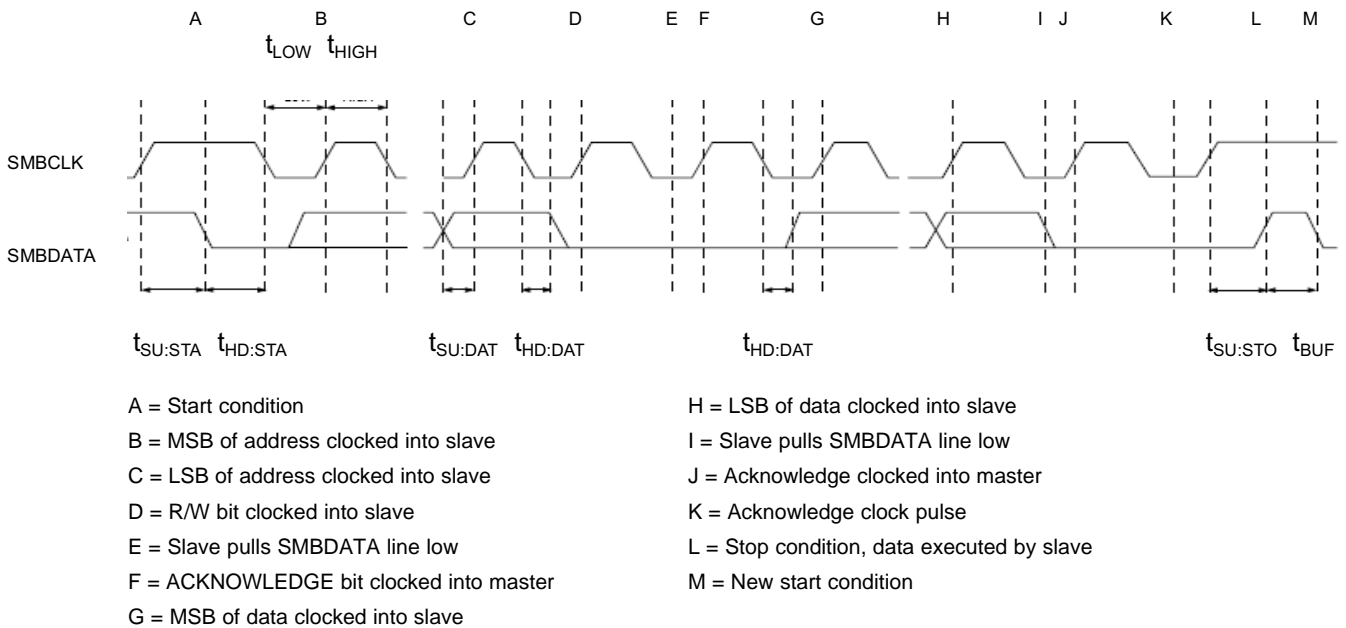

Figure 7. SMBus Write Timing

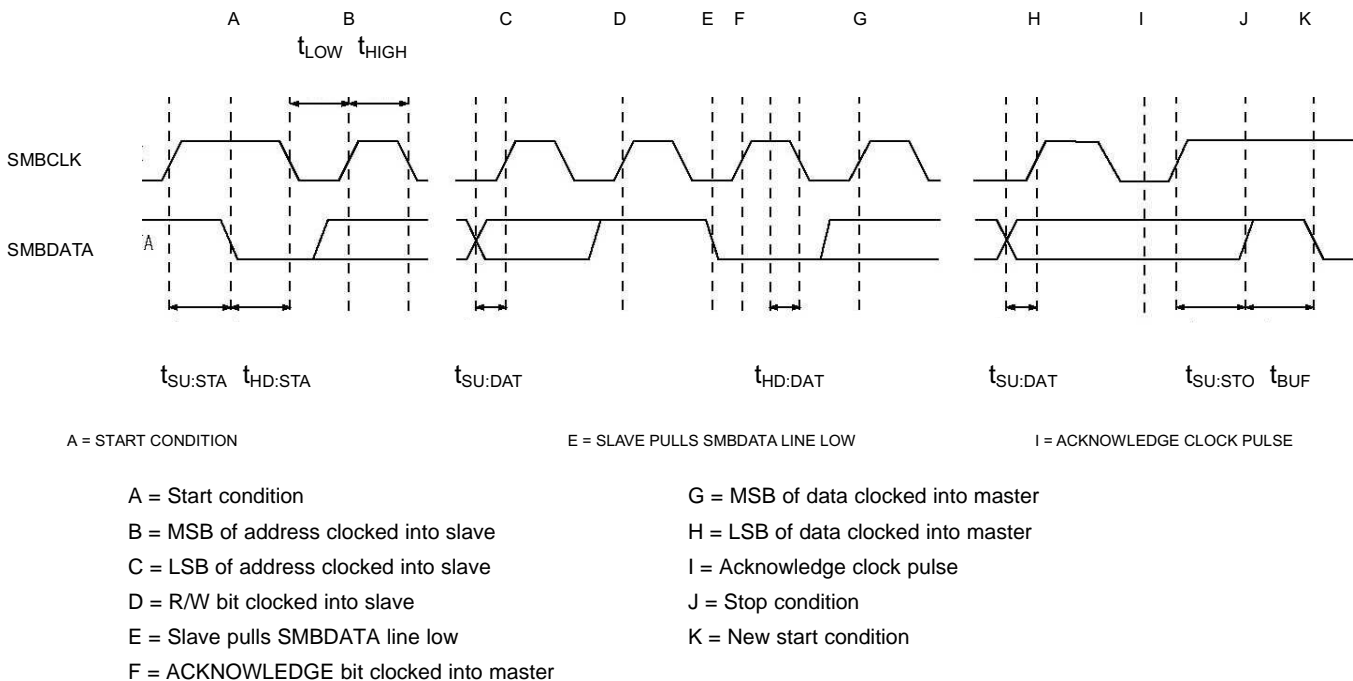

Figure 8. SMBus Read Timing

7.6 Register Maps

7.6.1 Battery-Charger Commands

The bq24780S supports thirteen battery-charger commands that use either Write-Word or Read-Word protocols, as summarized in [Table 4](#). ManufacturerID() and DeviceID() can be used to identify the bq24780S. The ManufacturerID() command always returns 0x0040H and the DeviceID() command always returns 0x0030H.

Table 4. Battery Charger Command Summary

REGISTER ADDRESS	REGISTER NAME	READ OR WRITE	DESCRIPTION	POR STATE
0x12H	ChargeOption0() Table 5	Read or Write	Charge Options Control 0	0xE108H
0x3BH	ChargeOption1() Table 6	Read or Write	Charge Options Control 1	0xC210H
0x38H	ChargeOption2() Table 7	Read or Write	Charge Options Control 2	0x0384H
0x37H	ChargeOption3() Table 8	Read or Write	Charge Options Control 3	0x1A40H
0x3CH	ProchotOption0() Table 9	Read or Write	$\overline{\text{PROCHOT}}$ Options Control 0	0x4A54H
0x3DH	ProchotOption1() Table 10	Read or Write	$\overline{\text{PROCHOT}}$ Options Control 1	0x8120H
0x3AH	ProchotStatus() Table 11	Read Only	$\overline{\text{PROCHOT}}$ status	0x0000H
0x14H	ChargeCurrent() Table 12	Read or Write	7-bit Charge Current Setting	0x0000H
0x15H	ChargeVoltage() Table 13	Read or Write	11-bit Charge Voltage Setting	0x0000H
0x39H	DischargeCurrent() Table 15	Read or Write	6-bit Discharge Current Setting	0x1800H, or 6144mA
0x3FH	InputCurrent() Table 14	Read or Write	6-bit Input Current Setting	0x1000H, or 4096mA
0xFEH	ManufacturerID()	Read Only	Manufacturer ID	0x0040H
0xFFH	DeviceID()	Read Only	Device ID	0x30H

7.6.2 Setting Charger Options

7.6.2.1 ChargeOption0 Register

Figure 9. ChargeOption0 Register (0x12H)

15	14	13	12	11	10	9	8
Low Power Mode Enable	WATCHDOG Timer Adjust		Reserved			Switching Frequency	
R/W	R/W		R			R/W	
7	6	5	4	3	2	1	0
Reserved		LEARN Mode Enable	IADP Amplifier Gain for Primary Input	IDCHG Amplifier Ratio	Reserved		Charge Inhibit
R		R/W	R/W	R/W	R		R/W

LEGEND: R/W = Read/Write; R = Read only; -n = value after reset

Table 5. ChargeOption0 Register (0x12H)

BIT	BIT NAME	DESCRIPTION
[15]	Low Power Mode Enable (EN_LWPWR)	0: IC in performance mode with battery only. The $\overline{\text{PROCHOT}}$, current/power monitor buffer and independent comparator follow register setting. 1: IC in low power mode with battery only. IC is in the lowest quiescent current when this bit is enabled. $\overline{\text{PROCHOT}}$, discharge current monitor buffer, power monitor buffer and independent comparator are disabled (default at POR)
[14:13]	WATCHDOG Timer Adjust (WDTMR_ADJ)	Set maximum delay between consecutive SMBus write charge voltage or charge current command. If IC does not receive write on REG0x14() or REG0x15() within the watchdog time period, the charger converter stops to disable charge and boost mode operation. After expiration, the timer will resume upon the write of REG0x14() or REG0x15(). The charge or boost operation will resume if all the other conditions are valid. 00: Disable watchdog timer 01: Enabled, 5 sec 10: Enabled, 88 sec 11: Enable watchdog timer (175 s) (default at POR)
[12:10]	Reserved	0 - Reserved
[9:8]	Switching Frequency (PWM_FREQ)	Converter switching frequency. 00: 600 kHz 01: 800 kHz (default at POR) 10: 1 MHz 11: Reserved
[7:6]	Reserved	0 - Reserved
[5]	LEARN Mode Enable (EN_LEARN)	Battery LEARN mode enable. In LEARN mode, ACFET and RBFET turns off and BATFET turns on. When /BATPRES is HIGH, IC exits LEARN mode and this bit is set back to 0. When the battery is depleted, the charger cannot enable LEARN mode 0: Disable LEARN mode (default at POR) 1: Enable LEARN mode
[4]	IADP Amplifier Gain for Primary Input (IADP_GAIN)	Ratio of IADP pin voltage over the voltage across ACP and ACN. 0: 20X (default at POR) 1: 40X
[3]	IDCHG Amplifier Gain (IDCHG_GAIN)	Ratio of IDCHG pin voltage over the voltage across SRN and SRP. 0: 8x with discharge current regulation range 0-32A. 0: 8x with discharge current regulation range 0-32A. 1: 16x with discharge current regulation range (default at POR)
[2:1]	Reserved	0 - Reserved
[0]	Charge Inhibit (CHRG_INHIBIT)	Charge inhibit. When this bit is 0, battery charging is enabled with valid value in REG0x14() and REG0x15() 0: Enable charge (default at POR) 1: Inhibit charge

7.6.3 ChargeOption1 Register

Figure 10. ChargeOption1 Register (0x3BH)

15	14	13	12	11	10	9	8
BAT Depletion Comparator Threshold		Input/Discharge Sense Resistor Ratio R		EN_IDCHG	EN_PMON	PMON Gain	Reserved
R/W		R/W		R/W	R/W	R/W	R
7	6	5	4	3	2	1	0
Independent Comparator Reference	Independent Comparator Polarity	Independent Comparator Deglitch Time		Power Path Latch-off Enable	Reserved	Discharge SRN for Shipping Mode_EN	Reserved
R/W	R/W	R/W		R/W	R	R/W	R

LEGEND: R/W = Read/Write; R = Read only; -n = value after reset

Table 6. ChargeOption1 Register (0x3BH)

BIT	BIT NAME	DESCRIPTION
[15:14]	Battery Depletion Threshold (BAT_DEPL_VTH)	Battery over-discharge threshold. During LEARN cycle, when battery voltage is below the depletion threshold, the IC exits LEARN mode. During boost mode, when battery voltage is below the depletion threshold, the IC exits boost mode. 00: Falling threshold = 59.19% of voltage regulation limit (~2.486V/cell) 01: Falling threshold = 62.65% of voltage regulation limit (~2.631V/cell) 10: Falling threshold = 66.55% of voltage regulation limit (~2.795V/cell) 11: Falling threshold = 70.97% of voltage regulation limit (2.981V/cell) (default at POR)
[13:12]	(RSNS_RATIO)	0 - Adjust the PMON calculation with different input sense resistor R_{AC} and charge sense resistor R_{SR} . 00: R_{AC} and R_{SR} 1:1 (default at POR) 01: R_{AC} and R_{SR} 2:1 10: R_{AC} and R_{SR} 1:2 11: Reserved
[11]	EN_IDCHG	IDCHG pin output enable. 0: Disable IDCHG output to minimize I_q (default at POR) 1: Enable IDCHG output
[10]	EN_PMON	PMON pin output enable. 0: Disable PMON output to minimize I_q (default at POR) 1: Enable PMON output
[9]	PMON Gain (PMON_RATIO)	Ratio of PMON output current vs total input and battery power with 10 mΩ sense resistor. 0: 0.25 μA/W 1: 1 μA/W (default at POR) With the sense resistor is 20/10 mΩ, or 10/20 mΩ, or 20/20mΩ (R_{AC} and R_{SR}) 0: 0.5 μA/W 1: 2 μA/W (default at POR)
[8]	Reserved	0 - Reserved
[7]	Independent Comparator Reference (CMP_REF)	Independent comparator internal reference. 0: 2.3 V (default at POR) 1: 1.2 V
[6]	Independent Comparator Polarity (CMP_POL)	Independent comparator output polarity 0: When CMPIN is above internal threshold, CMPOUT is LOW (default at POR) 1: When CMPIN is above internal threshold, CMPOUT is HIGH
[5:4]	Independent Comparator Deglitch Time (CMP_DEG)	Independent comparator deglitch time, applied on the edge where CMPOUT goes LOW. No deglitch time is applied on the rising edge of CMPOUT. 00: Independent comparator is disabled 01: Independent comparator is enabled with output deglitch time 1 μs (default at POR) 10: Independent comparator is enabled with output deglitch time 2 ms 11: Independent comparator is enabled with output deglitch time 5 sec
[3]	Power Path Latch-off Enable (EN_FET_LATCHOFF)	When independent comparator is triggered, both ACFET/RBFET turn off. The latch off is cleared by either POR or write this bit to zero. 0: When independent comparator is triggered, no power path latch off (default at POR) 1: When independent comparator is triggered, power path latches off.
[2]	Reserved	0 - Reserved
[1]	Discharge SRN for Shipping Mode (EN_SHIP_DCHG)	Discharge SRN pin for 140 ms with minimum 5-mA current. When 140 ms is over, this bit is reset to 0. 0: Disable discharge mode (default at POR) 1: Enable discharge mode
[0]	Reserved	0 - Reserved

7.6.4 ChargeOption2 Register
Figure 11. ChargeOption2 Register (0x38H)

15	14	13	12	11	10	9	8
Reserved						Reserved	
R						R	
7	6	5	4	3	2	1	0
Independent External Current Limit Enable	Reserved				Reserved	Reserved	
R/W	R				R	R	

LEGEND: R/W = Read/Write; R = Read only; -n = value after reset

Table 7. ChargeOption2 Register (0x38H)

BIT	BIT NAME	DESCRIPTION
[15:10]	Reserved	0 – Reserved
[9:8]	Reserved	1 - Reserved
[7]	External Current Limit Enable (EN_EXTILIM)	External ILIM pin enable to set the charge and discharge current. 0: Charge/discharge current limit is set by REG0x14() and 0x39(). 1: Charge/discharge current limit is set by the lower value of ILIM pin and registers. (default at POR)
[6:3]	Reserved	0 - Reserved
[2]	Reserved	1 - Reserved
[1:0]	Reserved	0 - Reserved

7.6.5 ChargeOption3 Register

Figure 12. ChargeOption3 Register (0x37H)

15	14	13	12	11	10	9	8
Discharge Current Regulation Enable	Reserved		ACOK Deglitch Time for Primary Input	Adapter Present Indicator	ACOC Enable	ACOC Limit	Reserved
R/W	R		R/W	R/W	R/W	R/W	R
7	6	5	4	3	2	1	0
HSFET VDS Threshold	LSFET VDS Threshold	Fast DPM Threshold	Fast DPM Deglitch Time		Hybrid Power Boost Mode Enable	Boost Mode Indication	Reserved
R/W	R/W	R/W	R/W		R/W	R/W	R

LEGEND: R/W = Read/Write; R = Read only; -n = value after reset

Table 8. ChargeOption3 Register (0x37H)

BIT	BIT NAME	DESCRIPTION
[15]	Discharge Current Regulation Enable(EN_IDCHG_REG)	Battery discharge current regulation enable. 0: Disable discharge current regulation (default at POR) 1: Enable discharge current regulation
[14:13]	Reserved	0 - Reserved
[12]	ACOK Deglitch Time for Primary Input (ACOK_DEG)	Adjust ACOK rising edge deglitch time. After POR, the first time adapter plugs in, deglitch time is always 150 ms regardless of register bit. Starting from the 2nd time adapter plugs in, the deglitch time follows the bit setting. During system over-current, or system short when ACDET is pulled below 2.4 V, 1.3 sec deglitch time keeps ACFET/RBFET turn off long enough before the next turn on. 0: ACOK rising edge deglitch time 150ms 1: ACOK rising edge deglitch time 1.3 sec (default at POR)
[11]	Adapter Present Indicator (ACOK_STAT)	Input present indicator. Same logic as ACOK pin. This bit is read only. 0: AC adapter is not present 1: AC adapter is present
[10]	ACOC Enable (EN_ACOC)	ACOC protection threshold by monitoring ACP_ACN voltage. 0: Disable ACOC (default at POR) 1: Enable ACOC
[9]	ACOC Limit (ACOC_VTH)	ACOC protection threshold by monitoring ACP_ACN voltage. 0: 125% of ICRIT 1: 200% of ICRIT (default at POR)
[8]	Reserved	0 – Reserved
[7]	HSFET VDS Threshold (IFault_HI)	MOSFET/inductor short protection by monitoring high side MOSFET drain-source voltage. 0: Disable (default at POR) 1: 750 mV
[6]	LSFET VDS Threshold (IFault_LO)	MOSFET/inductor short protection by monitoring low side MOSFET drain-source voltage. Also as cycle-by-cycle current limit protection threshold during boost function. 0: Disable 1: 250 mV (default at POR)
[5]	Fast DPM Threshold (FDPM_VTH)	Fast DPM comparator threshold to enter hybrid power boost mode. (Minimum DPM setting for boost mode: 1536 mA) 0: 107% (falling 93%)(default at POR) 1: 115% (falling 85%)
[4:3]	Fast DPM Deglitch Time (FDPM_DEG)	Response time from system current exceeding Fast DPM Threshold to battery discharge in boost mode. 00: Response time 150 μ s (default at POR) 01: Response time 250 μ s 1X: Response time 50 μ s
[2]	Hybrid Power Boost Mode Enable (EN_BOOST)	Boost mode enable bit. When /BATPRES goes from LOW to HIGH (battery removal), this bit will be reset to zero to disable boost mode. 0: Disable hybrid power boost mode (default at POR) 1: Enable hybrid power boost mode
[1]	Boost Mode Indication (BOOST_STAT)	In boost mode indicator. It goes LOW when the device is in boost mode. This bit is read only. 0: Charger is not in hybrid power boost mode (default at POR) 1: Charger is in hybrid power boost mode
[0]	Reserved	0 – Reserved

7.6.6 ProchotOption0 Register
Figure 13. ProchotOption0 Register (0x3CH)

15	14	13	12	11	10	9	8
ICRIT Threshold				ICRIT Deglitch time			Reserved
R/W				R/W			R
7	6	5	4	3	2	1	0
VSYS Threshold	PROCHOT Pulse Extension Enable	PROCHOT Pulse Width	PROCHOT Pulse Clear	PROCHOT Pulse Clear	INOM Deglitch Time	Reserved	
R/W	R/W	R/W	R/W	R/W	R/W	R/W	R

LEGEND: R/W = Read/Write; R = Read only; -n = value after reset

Table 9. ProchotOption0 Register (0x3CH)

BIT	BIT NAME	DESCRIPTION
[15:11]	ICRIT Threshold (ICRIT_VTH)	5 bits, percentage of IDPM in REG0x3F(). Measure current through ACP and ACN. Trigger when the current is above this threshold. 00000: 110% 00001: 110% 00010: 115% 00011: 120% 10010: 195% 10011: 200% 10100: 205% 10101: 210% 10110: 215% 10111: 220% 11000: 225% 11001: 230% 11010: 250% 11011: 300% 11100: 350% 11101: 400% 11110: 450% 11111: Out of Range Step: 5%, Default 150% (01001)
[10:9]	ICRIT Deglitch time (ICRIT_DEG)	Typical ICRIT deglitch time. 00: 10 µs 01: 100 µs (default at POR) 10: 400 µs 11: 800 µs
[8]	Reserved	0 – Reserved
[7:6]	VSYS Threshold (VSYS_VTH)	Measure on SRN with fixed 20-µs deglitch time. Trigger when SRN voltage is below the threshold. If REG0x15() is programmed below VSYS threshold, it is recommended to not enable VSYS in PROCHOT profile. 00: 5.75 V 01: 6 V (default at POR) 10: 6.25 V 11: 6.5 V
[5]	PROCHOT Pulse Extension Enable (EN_PROCHOT_EXT)	When pulse extension is enabled, keep PROCHOT pin voltage low until host write 0x3C[2] = 0. 0: Disable pulse extension (default at POR) 1: Enable pulse extension
[4:3]	PROCHOT Pulse Width (PROCHOT_WIDTH)	Minimum PROCHOT pulse width when REG0x3C[5]=0 00: 100 µs 01: 1 ms 10: 10 ms (default at POR) 11: 5 ms
[2]	PROCHOT Pulse Clear (PROCHOT_CLEAR)	Clear PROCHOT pulse when (0x3C[5] = 1). 0: Clear PROCHOT pulse and drive PROCHOT pin HIGH 1: Idle (default at POR)
[1]	INOM Deglitch Time (INOM_DEG)	Maximum INOM deglitch time. INOM threshold is 110% of IDPM in REG0x3F(). Measure current between ACP and ACN. Trigger when the current is above this threshold. 0: 1 ms (has to be max) (default at POR) 1: 60 ms (max)
[0]	Reserved	0 - Reserved

7.6.7 ProchotOption1 Register

Figure 14. ProchotOption1 Register (0x3DH)

15	14	13	12	11	10	9	8	
IDCHG Threshold						IDCHG comparator deglitch time		
R/W						R/W		
7	6	5	4	3	2	1	0	
Reserved	$\overline{\text{PROCHOT}}$ input current envelop selector							
R	R/W							

LEGEND: R/W = Read/Write; R = Read only; -n = value after reset

Table 10. ProchotOption1 Register (0x3DH)

BIT	BIT NAME	DESCRIPTION
[15:10]	IDCHG Threshold (IDCHG_VTH)	6 bit, range, range 0 A to 32256 mA, step 512 mA. Measure current between SRN and SRP. Trigger when the discharge current is above the threshold. Default: 16384 mA (100000)
[9:8]	IDCHG Deglitch Time (IDCHG_DEG)	Typical IDCHG deglitch time. 00: 1.6 ms 01: 100 μ s (default at POR) 10: 6 ms 11: 12 ms
[7]	Reserved	0 - Reserved
[6:0]	$\overline{\text{PROCHOT}}$ input current envelop selector (PROFILE)	When adapter is present, the $\overline{\text{PROCHOT}}$ function is enabled by the below bits. When adapter is removed, ICRIT, INOM, BATPRES, and ACOK functions are automatically disabled in the $\overline{\text{PROCHOT}}$ profile. Comparator, IDCHG, and VSYS function settings are preserved. When all the bits are 0, $\overline{\text{PROCHOT}}$ function is disabled. Bit 6: Independent comparator, 0: disable (default at POR); 1: enable Bit 5: ICRIT, 0: disable; 1: enable (default at POR) Bit 4: INOM, 0: disable (default at POR); 1: enable Bit 3: IDCHG, 0: disable (default at POR); 1: enable Bit 2: VSYS, 0: disable (default at POR); 1: enable Bit 1: BATPRES, 0: disable (default at POR) ; 1: enable (one-shot rising edge triggered) Bit 0: ACOK, 0: disable (default at POR) ; 1: enable (one-shot falling edge triggered)

7.6.8 ProchotStatus Register

Figure 15. ProchotStatus Register (0x3AH)

15	14	13	12	11	10	9	8	
Reserved								
R/W								
7	6	5	4	3	2	1	0	
Reserved	$\overline{\text{PROCHOT}}$ status							
R/W	R							

LEGEND: R/W = Read/Write; R = Read only; -n = value after reset

Table 11. ProchotStatus Register (0x3AH)

BIT	BIT NAME	DESCRIPTION
[15:7]	Reserved	0 - Reserved
[6:0]	$\overline{\text{PROCHOT}}$ status (Read only)	The status of all events triggered during the same $\overline{\text{PROCHOT}}$ pulse are set to 1. The register resets when either of below two conditions occurs. <ul style="list-style-type: none"> Host first read after $\overline{\text{PROCHOT}}$ goes high $\overline{\text{PROCHOT}}$ goes low to start another pulse. Bit 6: Independent comparator, 0: Not triggered; 1: Triggered Bit 5: ICRIT, 0: Not triggered; 1: Triggered Bit 4: INOM, 0: Not triggered; 1: Triggered Bit 3: IDCHG, 0: Not triggered; 1: Triggered Bit 2: VSYS, 0: Not triggered; 1: Triggered Bit 1: BATPRES, 0: Not triggered ; 1: Triggered Bit 0: ACOK, 0: Not triggered ; 1: Triggered

7.6.9 Setting the Charge Current

To set the charge current, write a 16-bit ChargeCurrent() command (0x14H or 0b00010100) using the data format listed in Table 12. With 10-mΩ sense resistor, the bq24780S device provides a charge current range of 128 mA to 8.128 A, with 64-mA step resolution. Upon POR, charge current is 0 A. Any conditions for ACOK low except ACOV resets the ChargeCurrent() to 0. Sending ChargeCurrent() 0 mA terminates charge.

To provide secondary protection, the bq24780S has an ILIM pin with which the user can program the maximum allowed charge current. Internal charge current limit is the lower one between the voltage set by ChargeCurrent(), and the voltage on ILIM pin. To disable this function, the user can pull ILIM above 2 V, which is the maximum charge current regulation limit. When ILIM is below 60 mV, battery charging is disabled. The preferred charge current limit can be derived from below equation:

$$I_{\text{CHG}} = \frac{V_{\text{ILIM}}}{20 \times R_{\text{SR}}} \quad (3)$$

The SRP and SRN pins are used to sense R_{SR} with default value of 10 mΩ. However, resistors of other values can also be used. For a larger sense resistor, a larger sense voltage is given, and a higher regulation accuracy; but, at the expense of higher conduction loss. If current sensing resistor value is too high, it may trigger an overcurrent protection threshold because the current ripple voltage is too high. In such a case, either a higher inductance value or a lower current sensing resistor value should be used to limit the current ripple voltage level. A current sensing resistor value no more than 20 mΩ is suggested.

Table 12. Charge Current Register (0x14H), Using 10-mΩ Sense Resistor

BIT	BIT NAME	DESCRIPTION
0		Not used; value ignored
1		Not used; value ignored
2		Not used; value ignored
3		Not used; value ignored
4		Not used; value ignored
5		Not used; value ignored
6	Charge Current, DACICHG 0	0 = Adds 0 mA of charger current 1 = Adds 64 mA of charger current
7	Charge Current, DACICHG 1	0 = Adds 0 mA of charger current 1 = Adds 128 mA of charger current
8	Charge Current, DACICHG 2	0 = Adds 0 mA of charger current 1 = Adds 256 mA of charger current
9	Charge Current, DACICHG 3	0 = Adds 0 mA of charger current 1 = Adds 512 mA of charger current
10	Charge Current, DACICHG 4	0 = Adds 0 mA of charger current 1 = Adds 1024 mA of charger current
11	Charge Current, DACICHG 5	0 = Adds 0 mA of charger current 1 = Adds 2048 mA of charger current
12	Charge Current, DACICHG 6	0 = Adds 0 mA of charger current 1 = Adds 4096 mA of charger current
13		Not used; 1 = invalid write
14		Not used; 1 = invalid write
15		Not used; 1 = invalid write

7.6.10 Setting the Charge Voltage

To set the output charge regulation voltage, write a 16-bit ChargeVoltage() command (0x15H or 0b00010101) using the data format listed in Table 13. The bq24780S device provides charge voltage range from 1.024 to 19.200 V, with 16-mV step resolution. Upon POR, charge voltage limit is 0 V. Sending ChargeVoltage() 0 mV terminates charge.

The SRN pin is used to sense the battery voltage for voltage regulation and should be connected as close to the battery as possible, and directly place a decoupling capacitor (0.1 μF recommended) as close to IC as possible to decouple high frequency noise.

Table 13. Charge Voltage Register (0x15H)

BIT	BIT NAME	DESCRIPTION
0		Not used; value ignored
1		Not used; value ignored
2		Not used; value ignored
3		Not used; value ignored
4	Charge voltage, DACV 0	0 = Adds 0 mV of charger voltage 1 = Adds 16 mV of charger voltage
5	Charge voltage, DACV 1	0 = Adds 0 mV of charger voltage 1 = Adds 32 mV of charger voltage
6	Charge voltage, DACV 2	0 = Adds 0 mV of charger voltage 1 = Adds 64 mV of charger voltage
7	Charge voltage, DACV 3	0 = Adds 0 mV of charger voltage 1 = Adds 128 mV of charger voltage
8	Charge voltage, DACV 4	0 = Adds 0 mV of charger voltage 1 = Adds 256 mV of charger voltage
9	Charge voltage, DACV 5	0 = Adds 0 mV of charger voltage 1 = Adds 512 mV of charger voltage
10	Charge voltage, DACV 6	0 = Adds 0 mV of charger voltage 1 = Adds 1024 mV of charger voltage
11	Charge voltage, DACV 7	0 = Adds 0 mV of charger voltage 1 = Adds 2048 mV of charger voltage
12	Charge voltage, DACV 8	0 = Adds 0 mV of charger voltage 1 = Adds 4096 mV of charger voltage
13	Charge voltage, DACV 9	0 = Adds 0 mV of charger voltage 1 = Adds 8192 mV of charger voltage
14	Charge voltage, DACV 10	0 = Adds 0 mV of charger voltage 1 = Adds 16384 mV of charger voltage
15		Not used; 1 = invalid write

7.6.11 Setting Input Current

System current normally fluctuates as portions of the system are powered-up or put to sleep. With the input current limit, the output current requirement of the AC wall adapter can be regulated its rating, reducing system cost.

The total input current, from a wall cube or other DC source, is the sum of the system supply current and the current required by the charger. When the input current exceeds the set input current limit, the bq24780S device decreases the charge current to provide priority to system load. As the system current rises, the available charge current drops linearly to 0. Thereafter, charger goes into hybrid power boost mode and adds battery power to support system load. During turbo-boost mode, input current stays in regulation.

During DPM regulation, the total input current is the sum of the device supply current I_{BIAS} , the charger input current, and the system load current I_{LOAD} , and can be estimated as follows:

$$I_{INPUT} = I_{LOAD} + \left[\frac{I_{BATTERY} \cdot V_{BATTERY}}{V_{IN} \cdot \eta} \right] + I_{BIAS} \quad (4)$$

In the above equation, η is the efficiency the switching regulator and $I_{BATTERY}$ is the battery charging or discharging current (positive for charging and negative for discharging). In charging mode, the charger converter is in buck configuration. In turbo-boost mode, the charger converter is in boost configuration.

To set the input current limit, write a 16-bit InputCurrent() command (0x3FH or 0b00111111) using the data format listed in Table 14. When using a 10-m Ω sense resistor, the bq24780S device provides an input-current limit range of 128 mA to 8.064 A, with 128-mA resolution. Upon POR, default input current limit is 4096 mA on 10-m Ω current sensing resistor (R_{AC}).

The ACP and ACN pins are used to sense R_{AC} with default value of 10 m Ω . However, resistors of other values can also be used. For a larger sense resistor, larger sense voltage is given, and higher regulation accuracy, but at the expense of higher conduction loss.

Table 14. Input Current Register (0x3FH), Using 10-mΩ Sense Resistor

BIT	BIT NAME	DESCRIPTION
0		Not used; value ignored
1		Not used; value ignored
2		Not used; value ignored
3		Not used; value ignored
4		Not used; value ignored
5		Not used; value ignored
6		Not used; value ignored
7	Input current, DACIIN 0	0 = Adds 0 mA of input current 1 = Adds 128 mA of input current
8	Input current, DACIIN 1	0 = Adds 0 mA of input current 1 = Adds 256 mA of input current
9	Input current, DACIIN 2	0 = Adds 0 mA of input current 1 = Adds 512 mA of input current
10	Input current, DACIIN 3	0 = Adds 0 mA of input current 1 = Adds 1024 mA of input current
11	Input current, DACIIN 4	0 = Adds 0 mA of input current 1 = Adds 2048 mA of input current
12	Input current, DACIIN 5	0 = Adds 0 mA of input current 1 = Adds 4096 mA of input current
13		Not used; 1 = invalid write
14		Not used; 1 = invalid write
15		Not used; 1 = invalid write

7.6.12 Setting the Discharge Current

To set the discharging current limit, write a 16-bit DischargeCurrent() command (0x39H or 0b00111111) using the data format listed in [Table 15](#). When using a 10-mΩ sense resistor, the bq24780S device provides a discharge current limit range of 512 mA to 32.256 A, with 512-mA resolution. Upon POR, default discharge current limit is 6.144 A on 10-mΩ current sensing resistor (R_{SR}).

To provide secondary protection during battery discharge, the bq24780S has an ILIM pin with which the user can program the maximum discharge current. Typically, the user sets the limit below battery pack over current protection (OCP) threshold for maximum battery discharge capacity. Refer to battery specification for OCP information. Internal discharge current limit is the lower one between the voltage set by DischargeCurrent(), and the voltage on ILIM pin. To disable this function, the user can pull ILIM pin above 1.6V, which is the maximum discharge current regulation limit. When ILIM is below 60mV, battery discharge is disabled. The preferred discharge current limit can be derived from [Equation 5](#).

$$I_{DCHG} = \frac{V_{ILIM}}{5 \times R_{SR}} \quad (5)$$

Table 15. Discharge Current Register (0x39H), Using 10-mΩ Sense Resistor

BIT	BIT NAME	DESCRIPTION
0		Not used; value ignored
1		Not used; value ignored
2		Not used; value ignored
3		Not used; value ignored
4		Not used; value ignored
5		Not used; value ignored
6		Not used; value ignored
7		Not used; value ignored
8		Not used; value ignored
9	Discharge current, DACIIN 0	0 = Adds 0 mA of input current 1 = Adds 512 mA of discharge current
10	Discharge current, DACIIN 1	0 = Adds 0 mA of input current 1 = Adds 1024 mA of discharge current
11	Discharge current, DACIIN 2	0 = Adds 0 mA of input current 1 = Adds 2048 mA of discharge current
12	Discharge current, DACIIN 3	0 = Adds 0 mA of input current 1 = Adds 4096 mA of discharge current
13	Discharge current, DACIIN 4	0 = Adds 0 mA of input current 1 = Adds 8192 mA of discharge current
14	Discharge current, DACIIN 5	0 = Adds 0 mA of input current 1 = Adds 16384 mA of discharge current
15		Not used; 1 = invalid write

8 Application and Implementation

NOTE

Information in the following applications sections is not part of the TI component specification, and TI does not warrant its accuracy or completeness. TI's customers are responsible for determining suitability of components for their purposes. Customers should validate and test their design implementation to confirm system functionality.

8.1 Application Information

The bq24780SEVM-583 evaluation module (EVM) is a complete charger module for evaluating the bq24780S. The application curves were taken using the bq24780SEVM-583. Refer to the EVM user's guide ([SLUUBA6](#)) for EVM information.

8.2 Typical Applications

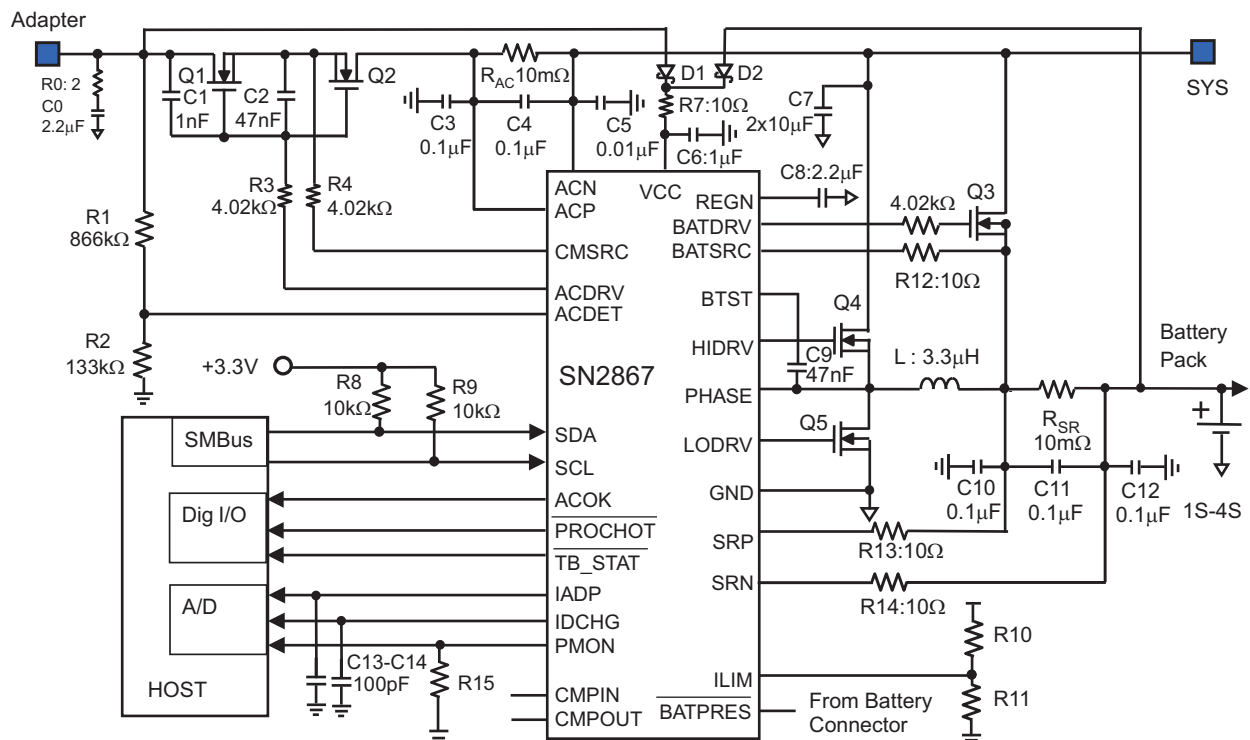

Figure 16. Typical System Schematic With Two NMOS Selectors

8.2.1 Design Requirements

DESIGN PARAMETER	EXAMPLE VALUE
Input Voltage ⁽¹⁾	17.7V < Adapter Voltage < 24V
Input Current Limit ⁽¹⁾	3.2A for 65W adapter
Battery Charge Voltage ⁽²⁾	12592mV for 3s battery
Battery Charge Current ⁽²⁾	4096mA for 3s battery
Battery Discharge Current ⁽²⁾	6144mA for 3s battery

(1) Refer to adapter specification for settings for Input Voltage and Input Current Limit.

(2) Refer to battery specification for settings.

8.2.2 Detailed Design Procedure

The parameters are configurable using the evaluation software.

The simplified application circuit (see Figure 16) shows the minimum capacitance requirements for each pin. Inductor, capacitor, and MOSFET selection are explained in the rest of this section. Refer to the EVM user's guide (SLUUBA6) for the full application schematic.

8.2.2.1 Negative Output Voltage Protection

Reversely insert the battery pack into the charger output during production or hard shorts on battery to ground will generate negative output voltage on SRP, SRN, and BATSRC pins. IC internal electrostatic-discharge (ESD) diodes from GND pin to SRP or SRN pins and two anti-parallel (AP) diodes between SRP and SRN pins can be forward biased and negative current can pass through the ESD diodes and AP diodes when output has negative voltage. Small resistors for SRP, SRN and BATSRC (R12-R14) further limits the negative current into these pins. Suggest resistor value is 10 Ω for SRP, SRN, and BATSRC pins.

8.2.2.2 Reverse Input Voltage Protection

Q6, R12, and R13 in Figure 17 give system and IC protection from reversed adapter voltage. In normal operation, Q6 is turned off by negative Vgs. When adapter voltage is reversed, Q6 Vgs is positive. As a result, Q6 turns on to short gate and source of Q2 so that Q2 is off. Q2 body diode blocks negative voltage to system. However, CMSRC and ACDRV pins need R3 and R4 to limit the current due to the ESD diode of these pins when turned on. Q6 must have low Vgs threshold voltage and low Qgs gate charge so it turns on before Q2 turns on. R3 and R4 must have enough power rating for the power dissipation when the ESD diode is on. If Q1 is replaced by Schottky diode for reverse adapter voltage protection, no extra small MOSFET and resistors are needed.

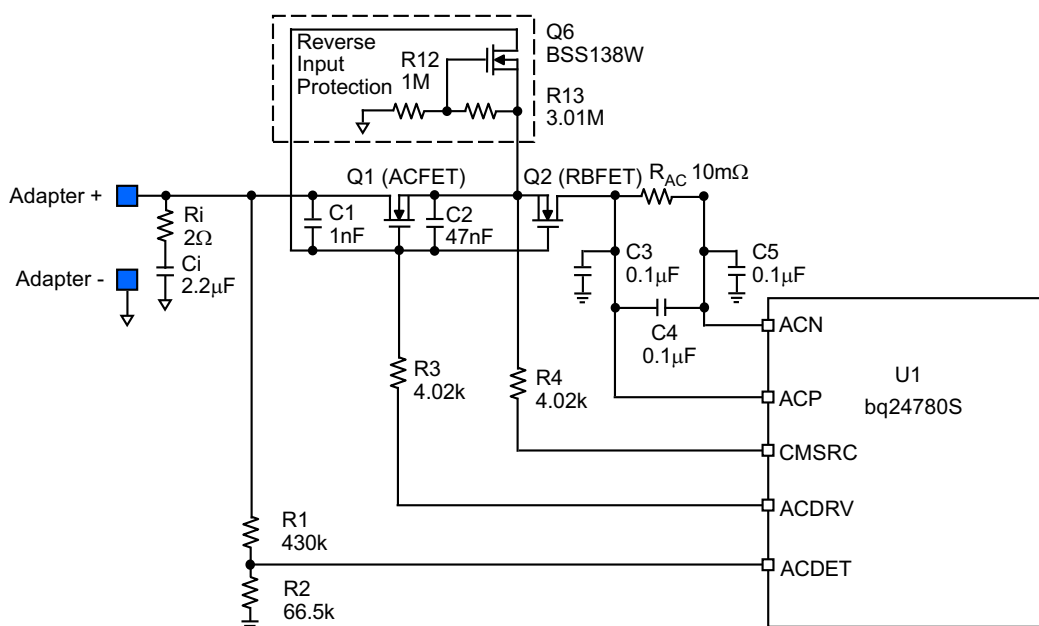

Figure 17. Reverse Input Voltage Protection Circuit

8.2.2.3 Reduce Battery Quiescent Current

When the adapter is not present, if VCC is powered with voltage higher than UVLO directly or indirectly (such as through a LDO or switching converter) from battery, the internal BATFET charge pump gives the BATFET pin 6-V higher voltage than the SRN pin to drive the n-channel BATFET. As a result, the battery has higher quiescent current. This is only necessary when the battery powers the system due to a high system current that goes through the MOSFET channel instead of the body diode to reduce conduction loss and extend the battery

working life. When the system is totally shutdown, it is not necessary to let the internal BATFET charge pump work. The host controller can turn off the switches in the battery pack to disconnect the battery from the system. Some packs may wake up again if the voltage on SRN pin stays above pack UVLO too long. By setting ChargeOption0() bit[1] to 1, host can enable current source inside charger IC to discharge the SRN pin quickly. As a result, the system is discharged down to zero to minimize the quiescent current.

8.2.2.4 Inductor Selection

The bq24780S has three selectable fixed switching frequency. Higher switching frequency allows the use of smaller inductor and capacitor values. Inductor saturation current should be higher than the charging current (I_{CHG}) plus half the ripple current (I_{RIPPLE}):

$$I_{SAT} \geq I_{CHG} + (1/2) I_{RIPPLE} \quad (6)$$

The inductor ripple current depends on input voltage (V_{IN}), duty cycle ($D = V_{OUT}/V_{IN}$), switching frequency (f_S) and inductance (L):

$$I_{RIPPLE} = \frac{V_{IN} \times D \times (1 - D)}{f_S \times L} \quad (7)$$

The maximum inductor ripple current happens with $D = 0.5$ or close to 0.5. For example, the battery charging voltage range is from 9V to 12.6V for 3-cell battery pack. For 20V adapter voltage, 10V battery voltage gives the maximum inductor ripple current. Another example is 4-cell battery, the battery voltage range is from 12V to 16.8V, and 12V battery voltage gives the maximum inductor ripple current.

Usually inductor ripple is designed in the range of (20-40%) maximum charging current as a trade-off between inductor size and efficiency for a practical design.

The bq24780S has charge under current protection (UCP) by monitoring charging current sensing resistor cycle-by-cycle. The typical cycle-by-cycle UCP threshold is 5mV falling edge corresponding to 0.5A falling edge for a 10mΩ charging current sensing resistor. When the average charging current is less than 125mA for a 10mΩ charging current sensing resistor, the low side MOSFET is off until BTST capacitor voltage needs to refresh the charge. As a result, the converter relies on low side MOSFET body diode for the inductor freewheeling current.

8.2.2.5 Input Capacitor

Input capacitor should have enough ripple current rating to absorb input switching ripple current. The worst case RMS ripple current is half of the charging current when duty cycle is 0.5. If the converter does not operate at 50% duty cycle, then the worst case capacitor RMS current occurs where the duty cycle is closest to 50% and can be estimated by [Equation 8](#):

$$I_{CIN} = I_{CHG} \times \sqrt{D \times (1 - D)} \quad (8)$$

Low ESR ceramic capacitor such as X7R or X5R is preferred for input decoupling capacitor and should be placed to the drain of the high side MOSFET and source of the low side MOSFET as close as possible. Voltage rating of the capacitor must be higher than normal input voltage level. 25V rating or higher capacitor is preferred for 19-20V input voltage. 10-20μF capacitance is suggested for typical of 3-4A charging current.

Ceramic capacitors show a dc-bias effect. This effect reduces the effective capacitance when a dc-bias voltage is applied across a ceramic capacitor, as on the input capacitor of a charger. The effect may lead to a significant capacitance drop, especially for high input voltages and small capacitor packages. See the manufacturer's data sheet about the performance with a dc bias voltage applied. It may be necessary to choose a higher voltage rating or nominal capacitance value in order to get the required value at the operating point.

8.2.2.6 Output Capacitor

Output capacitor also should have enough ripple current rating to absorb output switching ripple current. The output capacitor RMS current is given:

$$I_{COUT} = \frac{I_{RIPPLE}}{2 \times \sqrt{3}} \approx 0.29 \times I_{RIPPLE} \quad (9)$$

The bq24780S has internal loop compensator. To get good loop stability, the resonant frequency of the output inductor and output capacitor should be designed between 10 kHz and 20 kHz. The preferred ceramic capacitor is 25V X7R or X5R for output capacitor. 10-20 μ F capacitance is suggested for a typical of 3-4A charging current. Place the capacitors after charging current sensing resistor to get the best charge current regulation accuracy.

Ceramic capacitors show a dc-bias effect. This effect reduces the effective capacitance when a dc-bias voltage is applied across a ceramic capacitor, as on the output capacitor of a charger. The effect may lead to a significant capacitance drop, especially for high output voltages and small capacitor packages. See the manufacturer's data sheet about the performance with a dc bias voltage applied. It may be necessary to choose a higher voltage rating or nominal capacitance value in order to get the required value at the operating point.

8.2.2.7 Power MOSFETs Selection

Two external N-channel MOSFETs are used for a synchronous switching battery charger. The gate drivers are internally integrated into the IC with 6V of gate drive voltage. 30V or higher voltage rating MOSFETs are preferred for 19-20V input voltage.

Figure-of-merit (FOM) is usually used for selecting proper MOSFET based on a tradeoff between the conduction loss and switching loss. For the top side MOSFET, FOM is defined as the product of a MOSFET's on-resistance, $R_{DS(ON)}$, and the gate-to-drain charge, Q_{GD} . For the bottom side MOSFET, FOM is defined as the product of the MOSFET's on-resistance, $R_{DS(ON)}$, and the total gate charge, Q_G .

$$FOM_{top} = R_{DS(on)} \times Q_{GD}; FOM_{bottom} = R_{DS(on)} \times Q_G \quad (10)$$

The lower the FOM value, the lower the total power loss. Usually lower $R_{DS(ON)}$ has higher cost with the same package size.

The top-side MOSFET loss includes conduction loss and switching loss. It is a function of duty cycle ($D=V_{OUT}/V_{IN}$), charging current (I_{CHG}), MOSFET's on-resistance ($R_{DS(ON)}$), input voltage (V_{IN}), switching frequency (f_s), turn on time (t_{on}) and turn off time (t_{off}):

$$P_{top} = D \times I_{CHG}^2 \times R_{DS(on)} + \frac{1}{2} \times V_{IN} \times I_{CHG} \times (t_{on} + t_{off}) \times f_s \quad (11)$$

The first item represents the conduction loss. Usually MOSFET $R_{DS(ON)}$ increases by 50% with 100°C junction temperature rise. The second term represents the switching loss. The MOSFET turn-on and turn-off times are given by:

$$t_{on} = \frac{Q_{SW}}{I_{on}}, t_{off} = \frac{Q_{SW}}{I_{off}} \quad (12)$$

where Q_{SW} is the switching charge, I_{on} is the turn-on gate driving current and I_{off} is the turn-off gate driving current. If the switching charge is not given in MOSFET datasheet, it can be estimated by gate-to-drain charge (Q_{GD}) and gate-to-source charge (Q_{GS}):

$$Q_{SW} = Q_{GD} + \frac{1}{2} \times Q_{GS} \quad (13)$$

Gate driving current can be estimated by REGN voltage (V_{REGN}), MOSFET plateau voltage (V_{plt}), total turn-on gate resistance (R_{on}) and turn-off gate resistance (R_{off}) of the gate driver:

$$I_{on} = \frac{V_{REGN} - V_{plt}}{R_{on}}, I_{off} = \frac{V_{plt}}{R_{off}} \quad (14)$$

The conduction loss of the bottom-side MOSFET is calculated with the following equation when it operates in synchronous continuous conduction mode:

$$P_{bottom} = (1 - D) \times I_{CHG}^2 \times R_{DS(on)} \quad (15)$$

When charger operates in non-synchronous mode, the bottom-side MOSFET is off. As a result all the freewheeling current goes through the body-diode of the bottom-side MOSFET. The body diode power loss depends on its forward voltage drop (V_F), non-synchronous mode charging current (I_{NONSYN}), and duty cycle (D).

$$P_D = V_F \times I_{NONSYN} \times (1 - D) \quad (16)$$

The maximum charging current in non-synchronous mode can be up to 0.25A for a 10mΩ charging current sensing resistor or 0.5A if battery voltage is below 2.5V. The minimum duty cycle happens at lowest battery voltage. Choose the bottom-side MOSFET with either an internal Schottky or body diode capable of carrying the maximum non-synchronous mode charging current.

8.2.2.8 Input Filter Design

During adapter hot plug-in, the parasitic inductance and input capacitor from the adapter cable form a second order system. The voltage spike at VCC pin maybe beyond IC maximum voltage rating and damage IC. The input filter must be carefully designed and tested to prevent over voltage event on VCC pin.

There are several methods to damping or limit the over voltage spike during adapter hot plug-in. An electrolytic capacitor with high ESR as an input capacitor can damp the over voltage spike well below the IC maximum pin voltage rating. A high current capability TVS Zener diode can also limit the over voltage level to an IC safe level. However these two solutions may not have low cost or small size.

A cost effective and small size solution is shown in [Figure 18](#). The R1 and C1 are composed of a damping RC network to damp the hot plug-in oscillation. As a result the over voltage spike is limited to a safe level. D1 is used for reverse voltage protection for VCC pin. C2 is VCC pin decoupling capacitor and it should be place to VCC pin as close as possible. C2 value should be less than C1 value so R1 can dominant the equivalent ESR value to get enough damping effect. R2 is used to limit inrush current of D1 to prevent D1 getting damage when adapter hot plug-in. R2 and C2 should have 10us time constant to limit the dv/dt on VCC pin to reduce inrush current when adapter hot plug in. R1 has high inrush current. R1 package must be sized enough to handle inrush current power loss according to resistor manufacturer's data sheet. The filter components value always need to be verified with real application and minor adjustments may need to fit in the real application circuit.

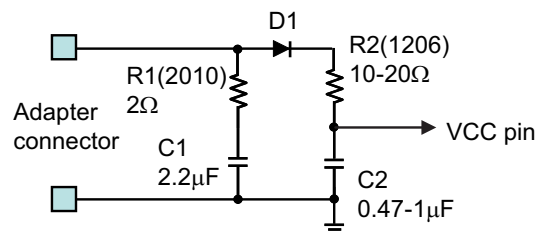
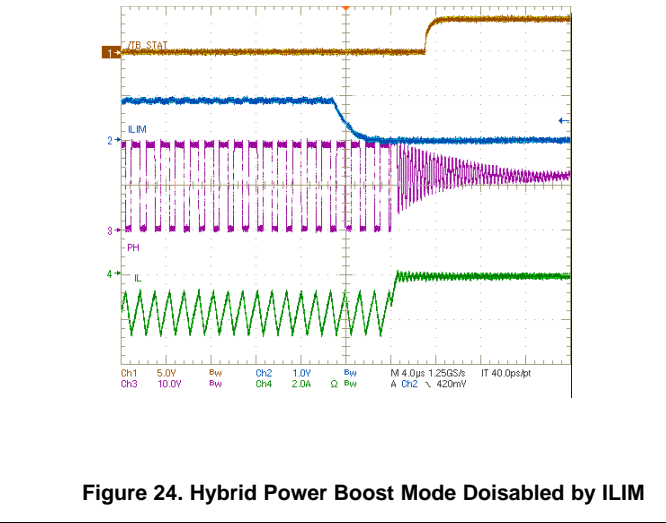
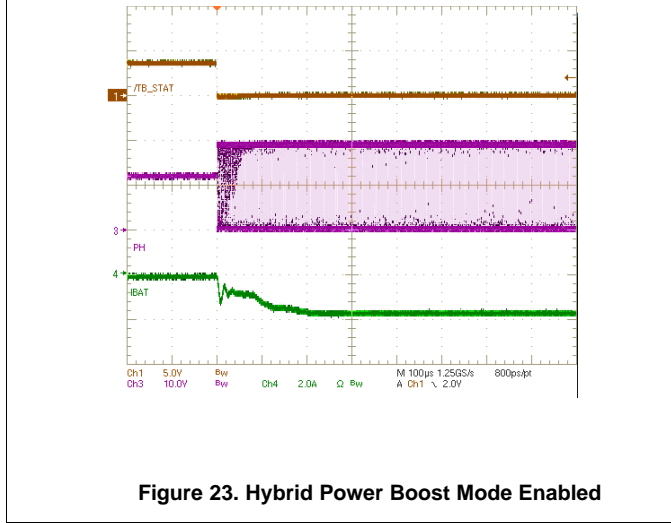
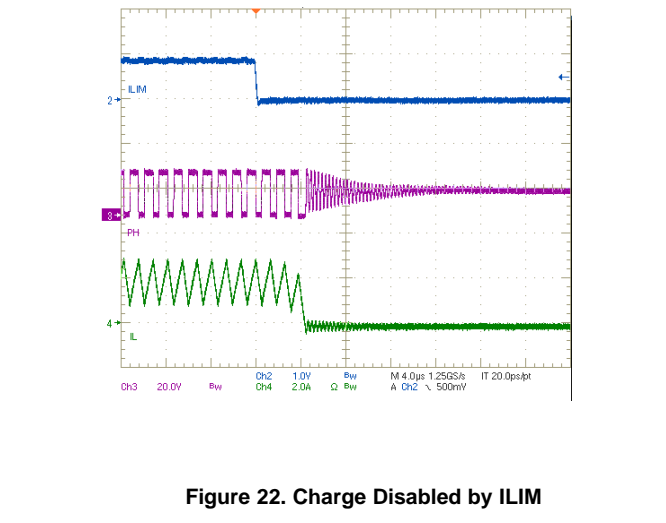
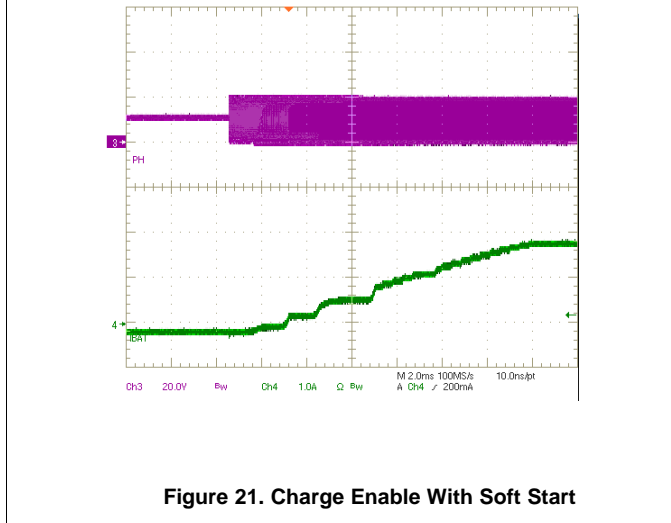
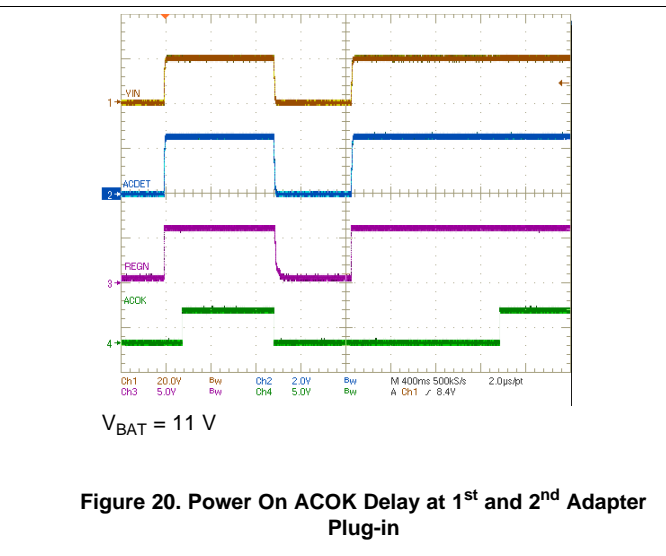
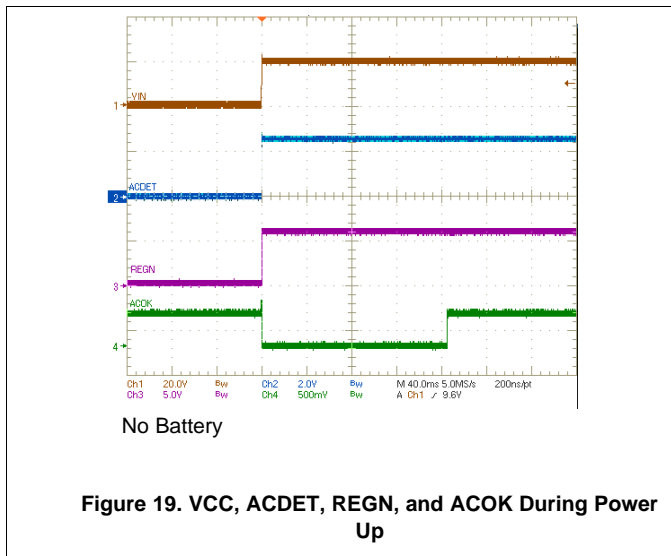

Figure 18. Input Filter

8.2.3 Application Curves



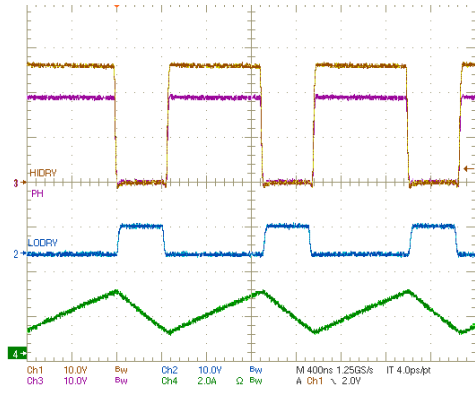

Figure 25. Converter in Continuous Conduction Mode (CCM) During Charging

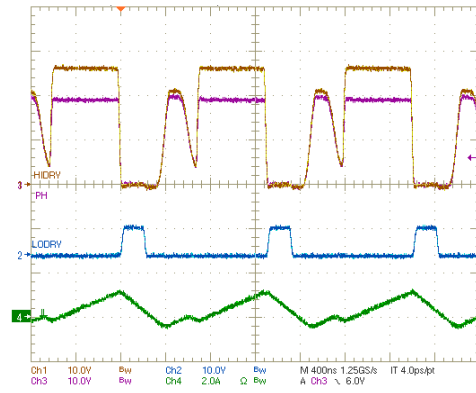

Figure 26. Converter in Discontinuous Conduction Mode (DCM) During Charging

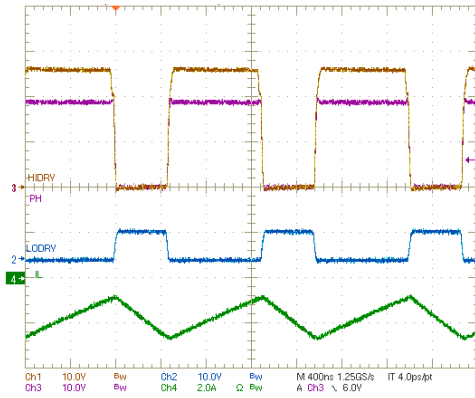
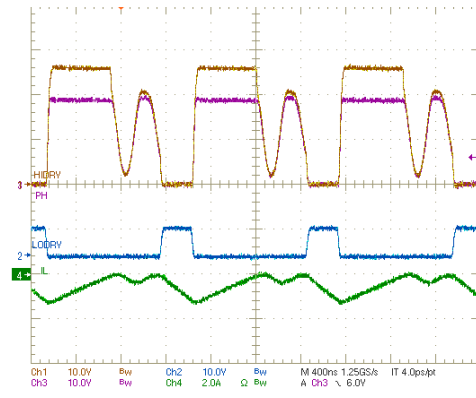
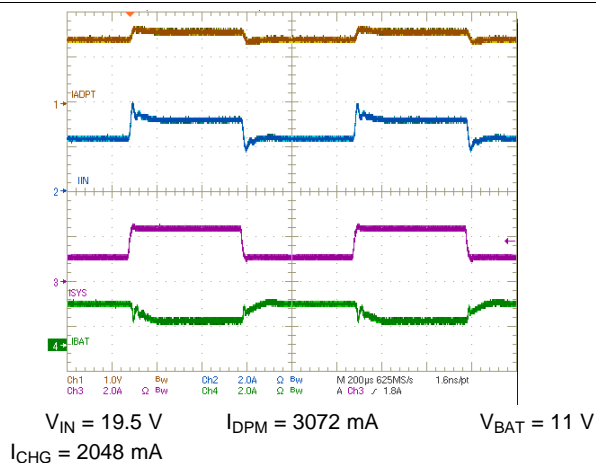

Figure 27. Converter in Continuous Conduction Mode During Hybrid Power Boost Mode



I_{DPM} 4096 mA I_{CHG} 2432 mA V_{BAT} 11 V

Figure 28. Converter in Discontinuous Conduction Mode During Hybrid Power Boost Mode



$V_{IN} = 19.5$ V $I_{DPM} = 3072$ mA $V_{BAT} = 11$ V
 $I_{CHG} = 2048$ mA

Figure 29. Input Current Regulation During System Load Transient

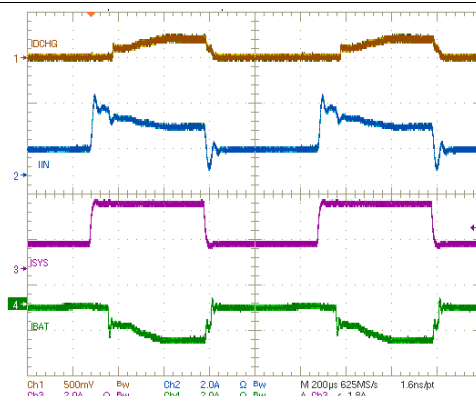

$V_{IN} = 19.5$ V $I_{DPM} = 2048$ mA $V_{BAT} = 11$ V

Figure 30. Hybrid Power Boost Mode With Charge Enable

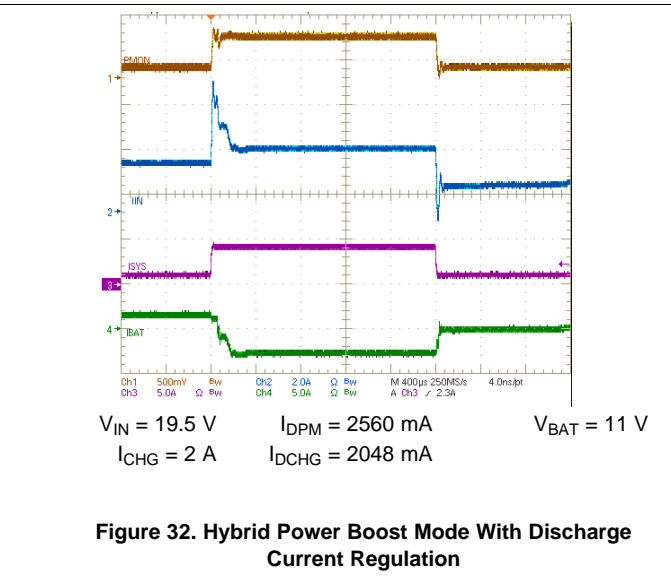
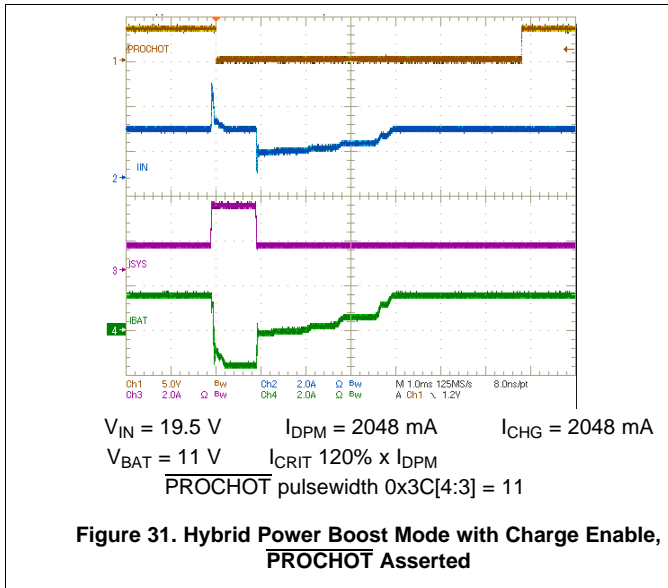

9 Power Supply Recommendations

When adapter is attached, and ACOK goes HIGH, the system is connected to adapter through ACFET/RBFET. An external resistor voltage divider attenuates the adapter voltage before it goes to ACDET. The adapter detect threshold should typically be programmed to a value greater than the maximum battery voltage, but lower than the IC maximum allowed input voltage (ACOV_P) and system maximum allowed voltage.

When adapter is removed, the system is connected to battery through BATFET. Typically the battery depletion threshold should be greater than the minimum system voltage so that the battery capacity can be fully utilized for maximum battery life.

10 Layout

10.1 Layout Guidelines

The switching node rise and fall times should be minimized for minimum switching loss. Proper layout of the components to minimize high frequency current path loop (see [Figure 33](#)) is important to prevent electrical and magnetic field radiation and high frequency resonant problems. Here is a PCB layout priority list for proper layout. Layout PCB according to this specific order is essential.

1. Place input capacitor as close as possible to switching MOSFET's supply and ground connections and use shortest copper trace connection. These parts should be placed on the same layer of PCB instead of on different layers and using vias to make this connection.
2. The IC should be placed close to the switching MOSFET's gate pins and keep the gate drive signal traces short for a clean MOSFET drive. The IC can be placed on the other side of the PCB of switching MOSFETs.
3. Place inductor input pin to switching MOSFET's output pin as close as possible. Minimize the copper area of this trace to lower electrical and magnetic field radiation but make the trace wide enough to carry the charging current. Do not use multiple layers in parallel for this connection. Minimize parasitic capacitance from this area to any other trace or plane.
4. The charging current sensing resistor should be placed right next to the inductor output. Route the sense leads connected across the sensing resistor back to the IC in same layer, close to each other (minimize loop area) and do not route the sense leads through a high-current path (see [Figure 34](#) for Kelvin connection for best current accuracy). Place decoupling capacitor on these traces next to the IC
5. Place output capacitor next to the sensing resistor output and ground
6. Output capacitor ground connections need to be tied to the same copper that connects to the input capacitor ground before connecting to system ground.
7. Use single ground connection to tie charger power ground to charger analog ground. Just beneath the IC use analog ground copper pour but avoid power pins to reduce inductive and capacitive noise coupling
8. Route analog ground separately from power ground. Connect analog ground and connect power ground separately. Connect analog ground and power ground together using power pad as the single ground connection point. Or using a 0Ω resistor to tie analog ground to power ground (power pad should tie to analog ground in this case if possible).
9. Decoupling capacitors should be placed next to the IC pins and make trace connection as short as possible
10. It is critical that the exposed power pad on the backside of the IC package be soldered to the PCB ground. Ensure that there are sufficient thermal vias directly under the IC, connecting to the ground plane on the other layers.
11. The via size and number should be enough for a given current path.

See the EVM design for the recommended component placement with trace and via locations. For the WQFN information, See [SCBA017](#) and [SLUA271](#).

10.2 Layout Examples

10.2.1 Layout Consideration of Current Path

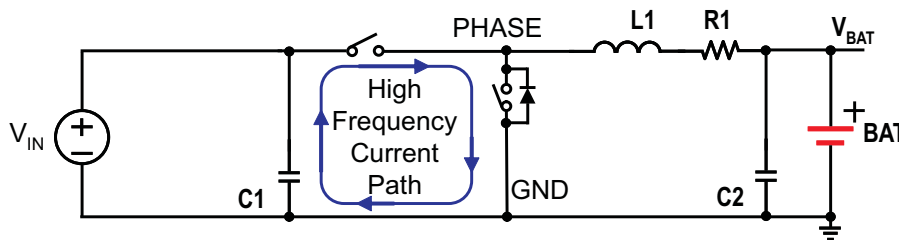

Figure 33. High Frequency Current Path

10.2.2 Layout Consideration of Short Circuit Protection

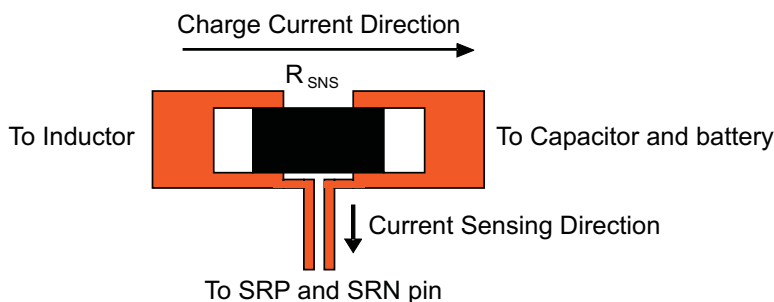
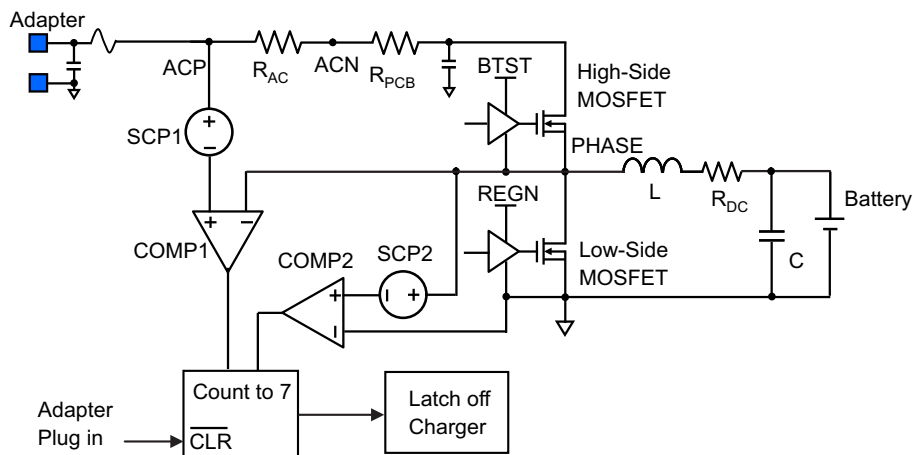

Figure 34. Sensing Resistor PCB Layout

10.2.3 Layout Consideration for Short Circuit Protection

The bq24780S has a unique short circuit protection feature. Its cycle-by-cycle current monitoring feature is achieved through monitoring the voltage drop across $R_{DS(on)}$ of the MOSFETs after a certain amount of blanking time. For a MOSFET short or inductor short circuit, the over current condition is sensed by two comparators, and two counters are triggered. After seven occurrences of a short circuit event, the charger will be latched off. To reset the charger from latch-off status, reconnect the adapter. Figure 35 shows the bq24780S short circuit protection block diagram.



Copyright © 2016, Texas Instruments Incorporated

Figure 35. Block Diagram of bq24780S Short Circuit Protection

Layout Examples (continued)

In normal operation, the low side MOSFET current is from source to drain which generates a negative voltage drop when it turns on, as a result the over current comparator can not be triggered. When the high side switch short circuit or inductor short circuit happens, the large current of low side MOSFET is from drain to source and can trigger low side switch over current comparator. The bq24780S senses the low side switch voltage drop through the PHASE pin and GND pin.

The high-side FET short is detected by monitoring the voltage drop between ACP and PHASE. As a result, it not only monitors the high side switch voltage drop, but also the adapter sensing resistor voltage drop and PCB trace voltage drop from ACN pin of R_{AC} to charger high side switch drain. Usually, there is a long trace between input sensing resistor and charger converting input, a careful layout will minimize the trace effect.

To prevent unintentional charger shut down in normal operation, MOSFET $R_{DS(on)}$ selection and PCB layout is very important. Figure 36 shows a improvement PCB layout example and its equivalent circuit. In this layout, the system current path and charger input current path is not separated, as a result, the system current causes voltage drop in the PCB copper and is sensed by the IC. The worst layout is when a system current pull point is after charger input; as a result all system current voltage drops are counted into over current protection comparator. The worst case for IC is when the total system current and charger input current sum equals the DPM current. When the system pulls more current, the charger IC tries to regulate the R_{AC} current as a constant current by reducing the charging current.

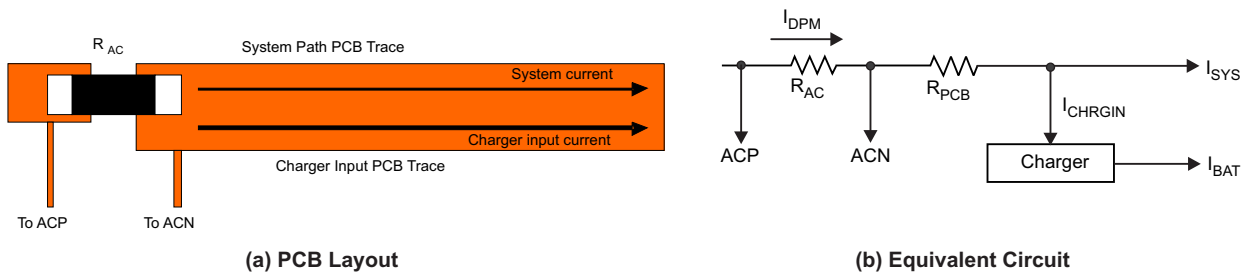

Figure 36. PCB Layout Example

Figure 37 shows the optimized PCB layout example. The system current path and charge input current path is separated, as a result the IC only senses charger input current caused PCB voltage drop and minimized the possibility of unintentional charger shut down in normal operation. This also makes PCB layout easier for high system current application.

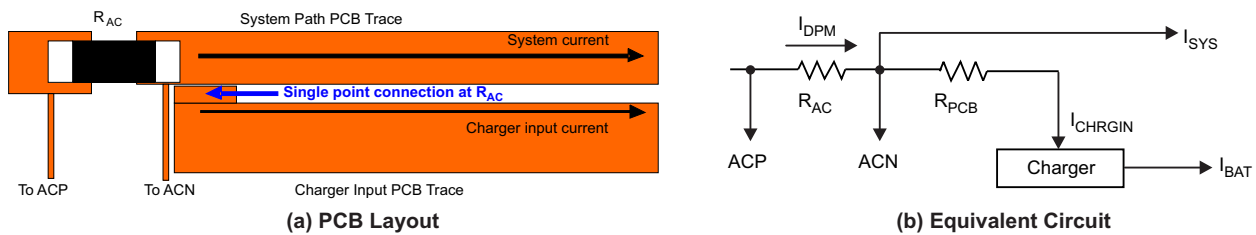

Figure 37. Optimized PCB Layout Example

The total voltage drop sensed by IC can be express as the following equation.

$$V_{top} = R_{AC} \times I_{DPM} + R_{PCB} \times (I_{CHRGIN} + (I_{DPM} - I_{CHRGIN}) \times k) + R_{DS(on)} \times I_{PEAK} \tag{17}$$

where the R_{AC} is the AC adapter current sensing resistance, I_{DPM} is the DPM current set point, R_{PCB} is the PCB trace equivalent resistance, I_{CHRGIN} is the charger input current, k is the PCB factor, $R_{DS(on)}$ is the high side MOSFET turn on resistance and I_{PEAK} is the peak current of inductor. Here the PCB factor k equals 0 means the best layout shown in Figure 37 where the PCB trace only goes through charger input current while k equals 1 means the worst layout shown in Figure 36 where the PCB trace goes through all the DPM current. The total voltage drop must below the high side short circuit protection threshold to prevent unintentional charger shut down in normal operation.

Layout Examples (continued)

The low side MOSFET short circuit voltage drop threshold can be adjusted via SMBus command. ChargeOption() bit[7] = 0, 1 set the low side threshold 135mV and 230mV respectively. The high side MOSFET short circuit voltage drop threshold can be adjusted via SMBus command. ChargeOption() bit[8] = 0, 1 disable the function and set the threshold 750mV respectively. For a fixed PCB layout, host should set proper short circuit protection threshold level to prevent unintentional charger shut down in normal operation.

11 Device and Documentation Support

11.1 Receiving Notification of Documentation Updates

To receive notification of documentation updates, navigate to the device product folder on ti.com. In the upper right corner, click on *Alert me* to register and receive a weekly digest of any product information that has changed. For change details, review the revision history included in any revised document.

11.2 Community Resources

The following links connect to TI community resources. Linked contents are provided "AS IS" by the respective contributors. They do not constitute TI specifications and do not necessarily reflect TI's views; see TI's [Terms of Use](#).

TI E2E™ Online Community *TI's Engineer-to-Engineer (E2E) Community*. Created to foster collaboration among engineers. At e2e.ti.com, you can ask questions, share knowledge, explore ideas and help solve problems with fellow engineers.

Design Support *TI's Design Support* Quickly find helpful E2E forums along with design support tools and contact information for technical support.

11.3 Trademarks

PowerPAD, E2E are trademarks of Texas Instruments.
Intel is a registered trademark of Intel Corporation.
All other trademarks are the property of their respective owners.

11.4 Electrostatic Discharge Caution



This integrated circuit can be damaged by ESD. Texas Instruments recommends that all integrated circuits be handled with appropriate precautions. Failure to observe proper handling and installation procedures can cause damage.

ESD damage can range from subtle performance degradation to complete device failure. Precision integrated circuits may be more susceptible to damage because very small parametric changes could cause the device not to meet its published specifications.

11.5 Glossary

[SLYZ022](#) — *TI Glossary*.

This glossary lists and explains terms, acronyms, and definitions.

12 Mechanical, Packaging, and Orderable Information

The following pages include mechanical packaging and orderable information. This information is the most current data available for the designated devices. This data is subject to change without notice and revision of this document. For browser-based versions of this data sheet, refer to the left-hand navigation.

PACKAGING INFORMATION

Orderable Device	Status (1)	Package Type	Package Drawing	Pins	Package Qty	Eco Plan (2)	Lead/Ball Finish (6)	MSL Peak Temp (3)	Op Temp (°C)	Device Marking (4/5)	Samples
BQ24780SRUYR	ACTIVE	WQFN	RUY	28	3000	Green (RoHS & no Sb/Br)	CU NIPDAU	Level-2-260C-1 YEAR	-40 to 85	BQ 24780S	Samples
BQ24780SRUYT	ACTIVE	WQFN	RUY	28	250	Green (RoHS & no Sb/Br)	CU NIPDAU	Level-2-260C-1 YEAR	-40 to 85	BQ 24780S	Samples

(1) The marketing status values are defined as follows:

ACTIVE: Product device recommended for new designs.

LIFEBUY: TI has announced that the device will be discontinued, and a lifetime-buy period is in effect.

NRND: Not recommended for new designs. Device is in production to support existing customers, but TI does not recommend using this part in a new design.

PREVIEW: Device has been announced but is not in production. Samples may or may not be available.

OBSELETE: TI has discontinued the production of the device.

(2) Eco Plan - The planned eco-friendly classification: Pb-Free (RoHS), Pb-Free (RoHS Exempt), or Green (RoHS & no Sb/Br) - please check <http://www.ti.com/productcontent> for the latest availability information and additional product content details.

TBD: The Pb-Free/Green conversion plan has not been defined.

Pb-Free (RoHS): TI's terms "Lead-Free" or "Pb-Free" mean semiconductor products that are compatible with the current RoHS requirements for all 6 substances, including the requirement that lead not exceed 0.1% by weight in homogeneous materials. Where designed to be soldered at high temperatures, TI Pb-Free products are suitable for use in specified lead-free processes.

Pb-Free (RoHS Exempt): This component has a RoHS exemption for either 1) lead-based flip-chip solder bumps used between the die and package, or 2) lead-based die adhesive used between the die and leadframe. The component is otherwise considered Pb-Free (RoHS compatible) as defined above.

Green (RoHS & no Sb/Br): TI defines "Green" to mean Pb-Free (RoHS compatible), and free of Bromine (Br) and Antimony (Sb) based flame retardants (Br or Sb do not exceed 0.1% by weight in homogeneous material)

(3) MSL, Peak Temp. - The Moisture Sensitivity Level rating according to the JEDEC industry standard classifications, and peak solder temperature.

(4) There may be additional marking, which relates to the logo, the lot trace code information, or the environmental category on the device.

(5) Multiple Device Markings will be inside parentheses. Only one Device Marking contained in parentheses and separated by a "~" will appear on a device. If a line is indented then it is a continuation of the previous line and the two combined represent the entire Device Marking for that device.

(6) Lead/Ball Finish - Orderable Devices may have multiple material finish options. Finish options are separated by a vertical ruled line. Lead/Ball Finish values may wrap to two lines if the finish value exceeds the maximum column width.

Important Information and Disclaimer: The information provided on this page represents TI's knowledge and belief as of the date that it is provided. TI bases its knowledge and belief on information provided by third parties, and makes no representation or warranty as to the accuracy of such information. Efforts are underway to better integrate information from third parties. TI has taken and continues to take reasonable steps to provide representative and accurate information but may not have conducted destructive testing or chemical analysis on incoming materials and chemicals. TI and TI suppliers consider certain information to be proprietary, and thus CAS numbers and other limited information may not be available for release.

In no event shall TI's liability arising out of such information exceed the total purchase price of the TI part(s) at issue in this document sold by TI to Customer on an annual basis.

TAPE AND REEL INFORMATION



QUADRANT ASSIGNMENTS FOR PIN 1 ORIENTATION IN TAPE



*All dimensions are nominal

Device	Package Type	Package Drawing	Pins	SPQ	Reel Diameter (mm)	Reel Width W1 (mm)	A0 (mm)	B0 (mm)	K0 (mm)	P1 (mm)	W (mm)	Pin1 Quadrant
BQ24780SRUYR	WQFN	RUY	28	3000	330.0	12.4	4.25	4.25	1.15	8.0	12.0	Q2
BQ24780SRUYT	WQFN	RUY	28	250	180.0	12.4	4.25	4.25	1.15	8.0	12.0	Q2

TAPE AND REEL BOX DIMENSIONS

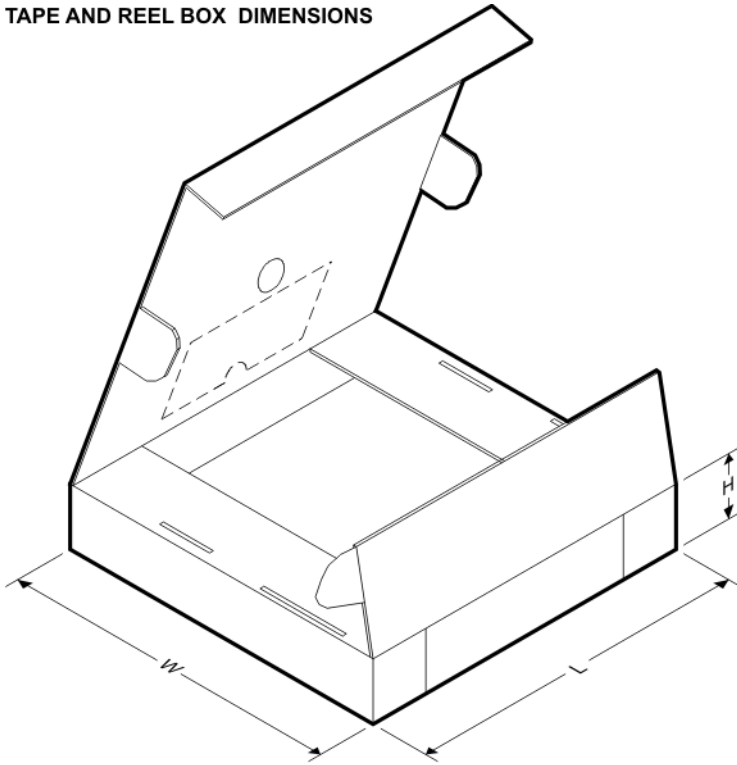

*All dimensions are nominal

Device	Package Type	Package Drawing	Pins	SPQ	Length (mm)	Width (mm)	Height (mm)
BQ24780SRUYR	WQFN	RUY	28	3000	367.0	367.0	35.0
BQ24780SRUYT	WQFN	RUY	28	250	210.0	185.0	35.0

RUY (S-PWQFN-N28)

PLASTIC QUAD FLATPACK NO-LEAD

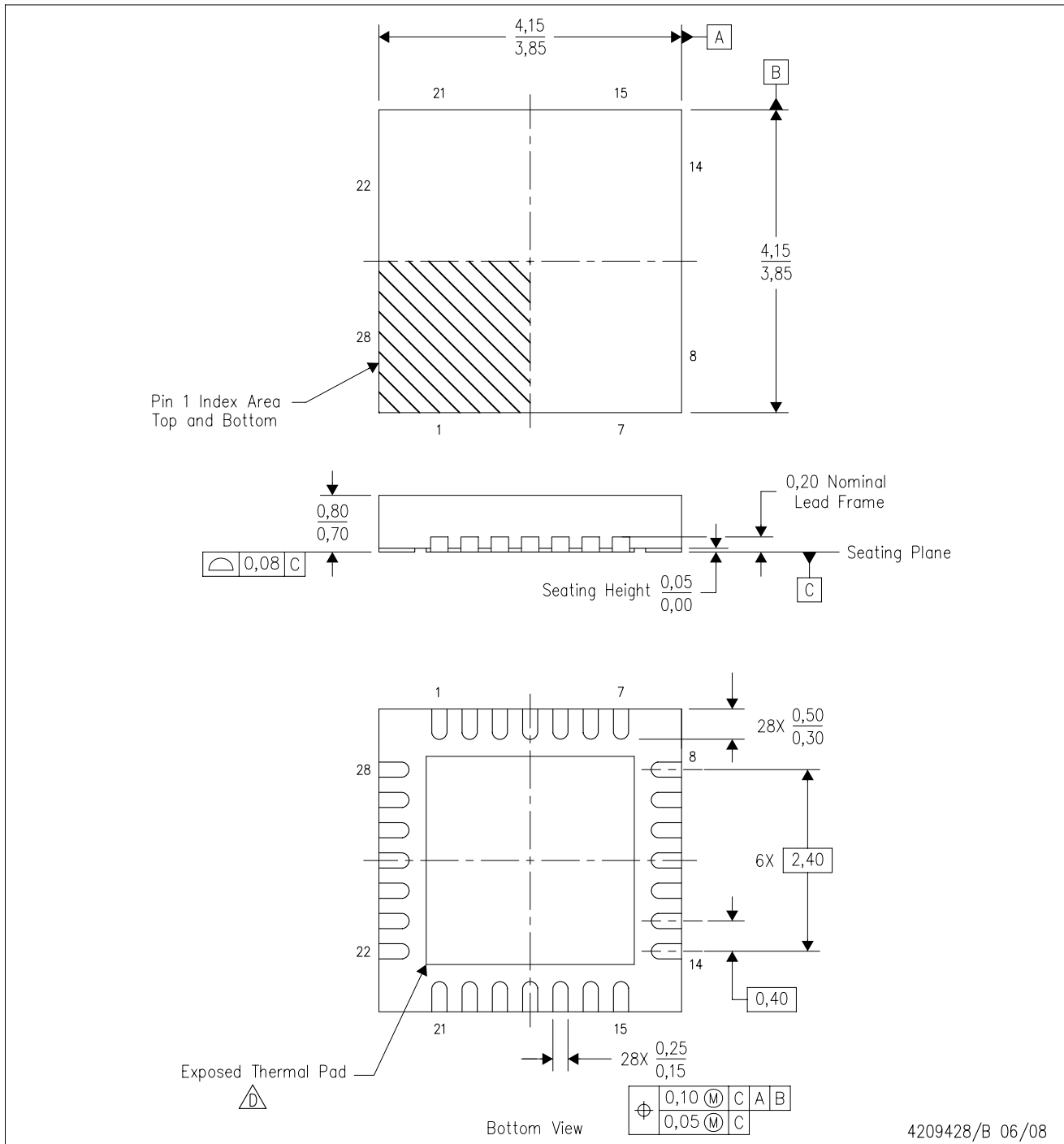

4209428/B 06/08

- NOTES:
- A. All linear dimensions are in millimeters. Dimensioning and tolerancing per ASME Y14.5M-1994.
 - B. This drawing is subject to change without notice.
 - C. QFN (Quad Flatpack No-Lead) package configuration.
 -  The package thermal pad must be soldered to the board for thermal and mechanical performance. See the Product Data Sheet for details regarding the exposed thermal pad dimensions.

THERMAL PAD MECHANICAL DATA

RUY (S-PWQFN-N28)

PLASTIC QUAD FLATPACK NO-LEAD

THERMAL INFORMATION

This package incorporates an exposed thermal pad that is designed to be attached directly to an external heatsink. The thermal pad must be soldered directly to the printed circuit board (PCB). After soldering, the PCB can be used as a heatsink. In addition, through the use of thermal vias, the thermal pad can be attached directly to the appropriate copper plane shown in the electrical schematic for the device, or alternatively, can be attached to a special heatsink structure designed into the PCB. This design optimizes the heat transfer from the integrated circuit (IC).

For information on the Quad Flatpack No-Lead (QFN) package and its advantages, refer to Application Report, QFN/SON PCB Attachment, Texas Instruments Literature No. SLUA271. This document is available at www.ti.com.

The exposed thermal pad dimensions for this package are shown in the following illustration.

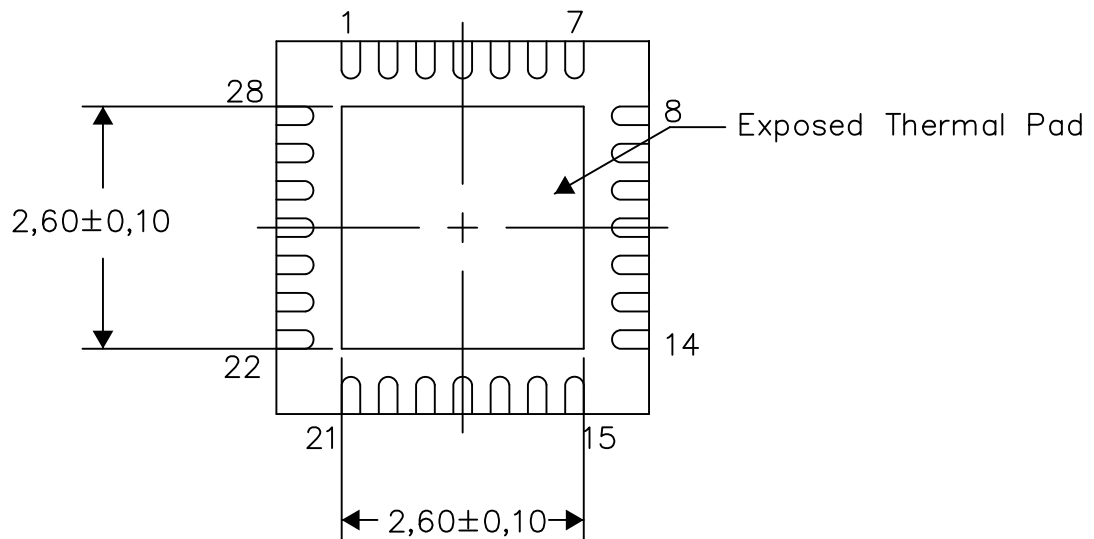

Bottom View

Exposed Thermal Pad Dimensions

4209490/F 07/15

NOTE: All linear dimensions are in millimeters

RUY (S-PWQFN-N28)

PLASTIC QUAD FLATPACK NO-LEAD

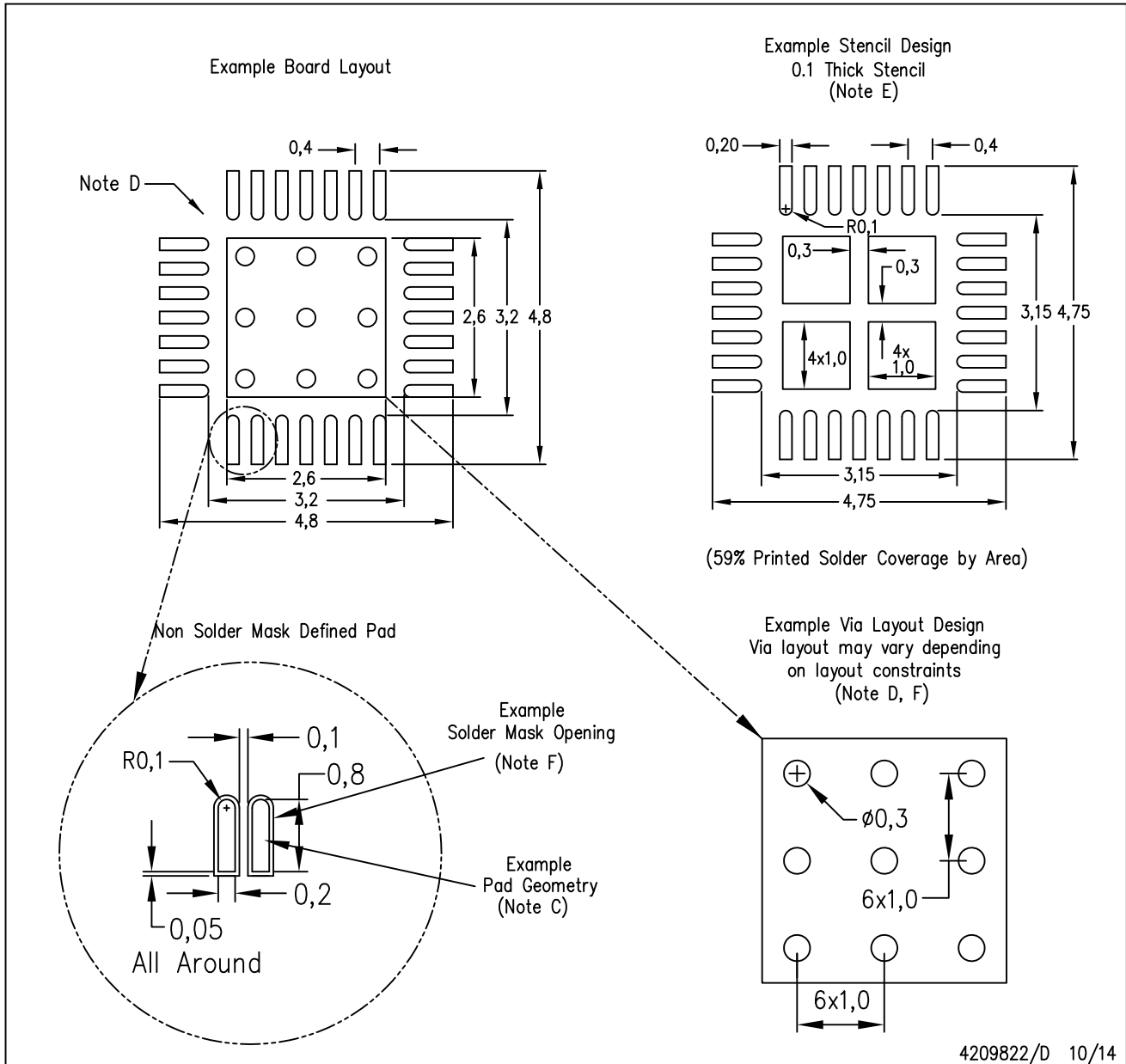

- NOTES:
- All linear dimensions are in millimeters.
 - This drawing is subject to change without notice.
 - Publication IPC-7351 is recommended for alternate designs.
 - This package is designed to be soldered to a thermal pad on the board. Refer to Application Note, Quad Flat-Pack Packages, Texas Instruments Literature No. SLUA271, and also the Product Data Sheets for specific thermal information, via requirements, and recommended board layout. These documents are available at www.ti.com <<http://www.ti.com>>.
 - Laser cutting apertures with trapezoidal walls and also rounding corners will offer better paste release. Customers should contact their board assembly site for stencil design recommendations. Refer to IPC 7525 for stencil design considerations.
 - Customers should contact their board fabrication site for recommended solder mask tolerances and via tenting recommendations for vias placed in the thermal pad.

IMPORTANT NOTICE

Texas Instruments Incorporated (TI) reserves the right to make corrections, enhancements, improvements and other changes to its semiconductor products and services per JESD46, latest issue, and to discontinue any product or service per JESD48, latest issue. Buyers should obtain the latest relevant information before placing orders and should verify that such information is current and complete.

TI's published terms of sale for semiconductor products (<http://www.ti.com/sc/docs/stdterms.htm>) apply to the sale of packaged integrated circuit products that TI has qualified and released to market. Additional terms may apply to the use or sale of other types of TI products and services.

Reproduction of significant portions of TI information in TI data sheets is permissible only if reproduction is without alteration and is accompanied by all associated warranties, conditions, limitations, and notices. TI is not responsible or liable for such reproduced documentation. Information of third parties may be subject to additional restrictions. Resale of TI products or services with statements different from or beyond the parameters stated by TI for that product or service voids all express and any implied warranties for the associated TI product or service and is an unfair and deceptive business practice. TI is not responsible or liable for any such statements.

Buyers and others who are developing systems that incorporate TI products (collectively, "Designers") understand and agree that Designers remain responsible for using their independent analysis, evaluation and judgment in designing their applications and that Designers have full and exclusive responsibility to assure the safety of Designers' applications and compliance of their applications (and of all TI products used in or for Designers' applications) with all applicable regulations, laws and other applicable requirements. Designer represents that, with respect to their applications, Designer has all the necessary expertise to create and implement safeguards that (1) anticipate dangerous consequences of failures, (2) monitor failures and their consequences, and (3) lessen the likelihood of failures that might cause harm and take appropriate actions. Designer agrees that prior to using or distributing any applications that include TI products, Designer will thoroughly test such applications and the functionality of such TI products as used in such applications.

TI's provision of technical, application or other design advice, quality characterization, reliability data or other services or information, including, but not limited to, reference designs and materials relating to evaluation modules, (collectively, "TI Resources") are intended to assist designers who are developing applications that incorporate TI products; by downloading, accessing or using TI Resources in any way, Designer (individually or, if Designer is acting on behalf of a company, Designer's company) agrees to use any particular TI Resource solely for this purpose and subject to the terms of this Notice.

TI's provision of TI Resources does not expand or otherwise alter TI's applicable published warranties or warranty disclaimers for TI products, and no additional obligations or liabilities arise from TI providing such TI Resources. TI reserves the right to make corrections, enhancements, improvements and other changes to its TI Resources. TI has not conducted any testing other than that specifically described in the published documentation for a particular TI Resource.

Designer is authorized to use, copy and modify any individual TI Resource only in connection with the development of applications that include the TI product(s) identified in such TI Resource. NO OTHER LICENSE, EXPRESS OR IMPLIED, BY ESTOPPEL OR OTHERWISE TO ANY OTHER TI INTELLECTUAL PROPERTY RIGHT, AND NO LICENSE TO ANY TECHNOLOGY OR INTELLECTUAL PROPERTY RIGHT OF TI OR ANY THIRD PARTY IS GRANTED HEREIN, including but not limited to any patent right, copyright, mask work right, or other intellectual property right relating to any combination, machine, or process in which TI products or services are used. Information regarding or referencing third-party products or services does not constitute a license to use such products or services, or a warranty or endorsement thereof. Use of TI Resources may require a license from a third party under the patents or other intellectual property of the third party, or a license from TI under the patents or other intellectual property of TI.

TI RESOURCES ARE PROVIDED "AS IS" AND WITH ALL FAULTS. TI DISCLAIMS ALL OTHER WARRANTIES OR REPRESENTATIONS, EXPRESS OR IMPLIED, REGARDING RESOURCES OR USE THEREOF, INCLUDING BUT NOT LIMITED TO ACCURACY OR COMPLETENESS, TITLE, ANY EPIDEMIC FAILURE WARRANTY AND ANY IMPLIED WARRANTIES OF MERCHANTABILITY, FITNESS FOR A PARTICULAR PURPOSE, AND NON-INFRINGEMENT OF ANY THIRD PARTY INTELLECTUAL PROPERTY RIGHTS. TI SHALL NOT BE LIABLE FOR AND SHALL NOT DEFEND OR INDEMNIFY DESIGNER AGAINST ANY CLAIM, INCLUDING BUT NOT LIMITED TO ANY INFRINGEMENT CLAIM THAT RELATES TO OR IS BASED ON ANY COMBINATION OF PRODUCTS EVEN IF DESCRIBED IN TI RESOURCES OR OTHERWISE. IN NO EVENT SHALL TI BE LIABLE FOR ANY ACTUAL, DIRECT, SPECIAL, COLLATERAL, INDIRECT, PUNITIVE, INCIDENTAL, CONSEQUENTIAL OR EXEMPLARY DAMAGES IN CONNECTION WITH OR ARISING OUT OF TI RESOURCES OR USE THEREOF, AND REGARDLESS OF WHETHER TI HAS BEEN ADVISED OF THE POSSIBILITY OF SUCH DAMAGES.

Unless TI has explicitly designated an individual product as meeting the requirements of a particular industry standard (e.g., ISO/TS 16949 and ISO 26262), TI is not responsible for any failure to meet such industry standard requirements.

Where TI specifically promotes products as facilitating functional safety or as compliant with industry functional safety standards, such products are intended to help enable customers to design and create their own applications that meet applicable functional safety standards and requirements. Using products in an application does not by itself establish any safety features in the application. Designers must ensure compliance with safety-related requirements and standards applicable to their applications. Designer may not use any TI products in life-critical medical equipment unless authorized officers of the parties have executed a special contract specifically governing such use. Life-critical medical equipment is medical equipment where failure of such equipment would cause serious bodily injury or death (e.g., life support, pacemakers, defibrillators, heart pumps, neurostimulators, and implantables). Such equipment includes, without limitation, all medical devices identified by the U.S. Food and Drug Administration as Class III devices and equivalent classifications outside the U.S.

TI may expressly designate certain products as completing a particular qualification (e.g., Q100, Military Grade, or Enhanced Product). Designers agree that it has the necessary expertise to select the product with the appropriate qualification designation for their applications and that proper product selection is at Designers' own risk. Designers are solely responsible for compliance with all legal and regulatory requirements in connection with such selection.

Designer will fully indemnify TI and its representatives against any damages, costs, losses, and/or liabilities arising out of Designer's non-compliance with the terms and provisions of this Notice.

Looking for pricing, stock, or lifecycle information?

Click below to explore more details on WIN SOURCE:

 [View BQ24780SRUYT](#) on WIN SOURCE

 [Texas Instruments](#) Information

Optimize Your Supply Chain with WIN SOURCE Solutions

-  Global Sourcing Solution
-  Obsolete Management
-  Cost Control Management
-  Shortage Management
-  Alternative Solution
-  Excess Inventory Management