



**THE DATASHEET OF  
ADF5904WCCPZ-RL7**



## FEATURES

**Integrated baluns for single-ended receiver (Rx) inputs and local oscillator (LO) input**  
**Rx channel gain: 22 dB**  
**Noise figure (NF): 10 dB**  
**P1dB: -10 dBm**  
**LO input range: -8 dBm to +5 dBm**  
**Rx to IF isolation: 30 dB**  
**RF signal bandwidth: 250 MHz**  
**Rx output impedance: 900  $\Omega$  differential**  
**LO input buffer: 24 GHz**  
**RF and LO S11 at 50  $\Omega$ : -5 dB**  
**Temperature sensor with analog output:  $\pm 5^\circ$**   
**Electrostatic discharge (ESD) performance**  
**Human body model (HBM): 2000 V**  
**Charged device model (CDM): 500 V**  
**Qualified for automotive applications**

## APPLICATIONS

**Automotive radars**  
**Industrial radars**  
**Microwave ( $\mu$ W) radar sensors**

## GENERAL DESCRIPTION

The [ADF5904](#) is a 4-channel, 24 GHz, receiver downconverter. Each channel contains a single-ended RF input with an on-chip balun followed by a differential low noise amplifier (LNA) and a downconverter mixer with differential output buffers. The RF LO path also has an on-chip balun.

Control of the on-chip registers is through a simple 3-wire interface.

The [ADF5904](#) comes in a compact 32-lead, 5 mm  $\times$  5 mm LFCSP package.

## FUNCTIONAL BLOCK DIAGRAM

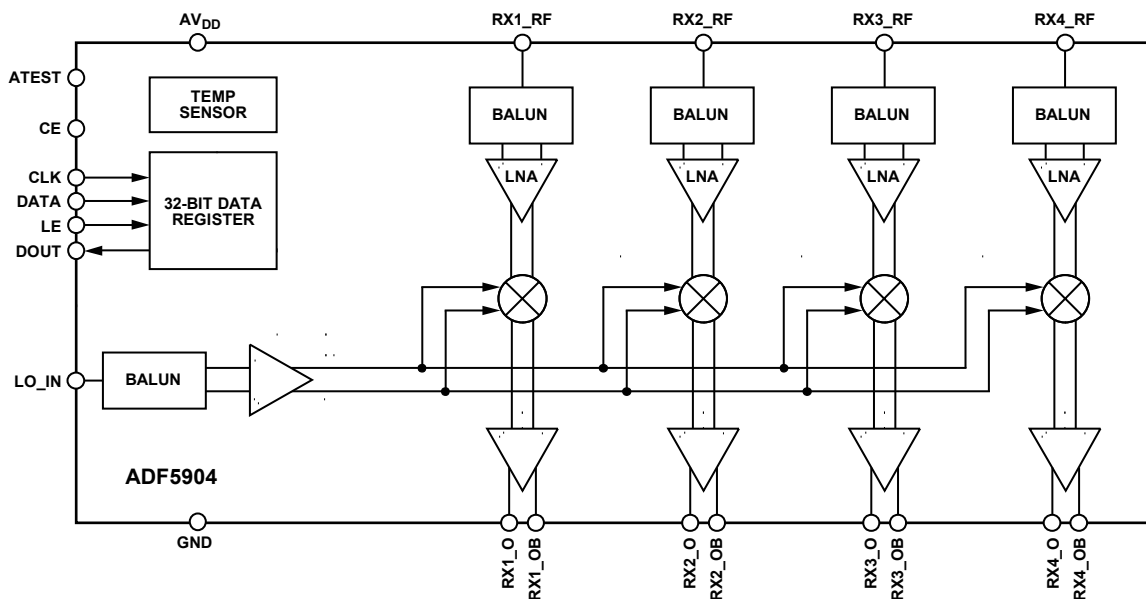

Figure 1.

12885-001

Rev. A

[Document Feedback](#)

Information furnished by Analog Devices is believed to be accurate and reliable. However, no responsibility is assumed by Analog Devices for its use, nor for any infringements of patents or other rights of third parties that may result from its use. Specifications subject to change without notice. No license is granted by implication or otherwise under any patent or patent rights of Analog Devices. Trademarks and registered trademarks are the property of their respective owners.

One Technology Way, P.O. Box 9106, Norwood, MA 02062-9106, U.S.A.  
 Tel: 781.329.4700 ©2015–2016 Analog Devices, Inc. All rights reserved.  
[Technical Support](#) [www.analog.com](http://www.analog.com)

**TABLE OF CONTENTS**

Features .....	1	Input Shift Register .....	9
Applications.....	1	Program Modes .....	9
General Description .....	1	Register Map .....	10
Functional Block Diagram .....	1	Register 0 .....	11
Revision History .....	2	Register 1 .....	12
Specifications.....	3	Register 2 .....	12
Timing Characteristics .....	4	Initialization Sequence .....	13
Absolute Maximum Ratings.....	5	Temperature Sensor .....	13
ESD Caution.....	5	Application Information.....	14
Pin Configuration and Function Descriptions.....	6	Application of the ADF5904 in FMCW Radar .....	14
Typical Performance Characteristics .....	7	Outline Dimensions .....	15
Theory of Operation .....	9	Ordering Guide .....	15
RF Path.....	9	Automotive Products.....	15
LO Path .....	9		

**REVISION HISTORY**

**2/16—Rev. 0 to Rev. A**

Changes to Features Section.....	1
Change to Parameter HBM, Table 3 .....	5
Change to Temperature Sensor Section.....	13
Changes to Ordering Guide .....	15

**3/15—Revision 0: Initial Version**

## SPECIFICATIONS

$AV_{DD} = 3.3\text{ V} \pm 5\%$ ,  $GND = 0\text{ V}$ , dBm referred to  $50\ \Omega$ ,  $T_A = T_{MAX}$  to  $T_{MIN}$ , unless otherwise noted. Operating temperature range is  $-40^\circ\text{C}$  to  $+105^\circ\text{C}$ .

**Table 1.**

Parameter	Symbol	Min	Typ	Max	Unit	Test Conditions/Comments
OPERATING CONDITIONS						
LO and RF Frequency Range		24		24.25	GHz	
LO INPUT						
Input Return Loss (S11)			-5		dB	
LO Input Level		-8	-5	+5	dBm	
BASEBAND OUTPUTS						
Voltage Conversion Gain			22		dB	Measured differentially Maximum capacitance = 10 pF
Demodulation Bandwidth			10		MHz	
Output DC Offset (Differential)			$\pm 20$		mV	Differential $900\ \Omega$ load
Output Common Mode			$AV_{DD} - 1.0$		V	
Output Swing			2		V peak	
Channel to Channel Phase Mismatch over Temperature			$\pm 5$		Degrees	
DYNAMIC PERFORMANCE, RF = 24.125 GHz						
Conversion Gain			22		dB	Terminated in $50\ \Omega$
Input P1dB			-10		dBm	
RF Input Return Loss			-5		dB	
Second-Order Input Intercept	IIP2		20		dBm	
Third-Order Input Intercept	IIP3		0		dBm	
LO to RF Isolation			30		dB	
RF to IF Isolation			30		dB	
Noise Figure			10		dB	
Noise Figure Under Blocking Conditions			15		dB	
LOGIC INPUTS						
Input Voltage						
High	$V_{IH}$	1.4			V	
Low	$V_{IL}$			0.6	V	
Input Current	$I_{INH}, I_{INL}$			$\pm 1$	$\mu\text{A}$	
Input Capacitance	$C_{IN}$			10	pF	
LOGIC OUTPUTS						
Output Voltage						
High	$V_{OH}$	$V_{DD} - 0.4$			V	$V_{DD}$ selected from the DOUT VSEL bit (Bit DB8, Register 0)
Low	$V_{OL}$			0.4	V	
Output Current						
High	$I_{OH}$			500	$\mu\text{A}$	
Low	$I_{OL}$			500	$\mu\text{A}$	
TEMPERATURE SENSOR						
Analog Accuracy			$\pm 5$		$^\circ\text{C}$	Following one-point calibration
Sensitivity			4.243		mV/ $^\circ\text{C}$	
POWER SUPPLIES						
$AV_{DD}$			170		mA	
Power-Down Current			100		$\mu\text{A}$	

**TIMING CHARACTERISTICS**

$V_{DD} = 3.3\text{ V} \pm 5\%$ ,  $GND = 0\text{ V}$ , dBm referred to  $50\ \Omega$ ,  $T_A = T_{MAX}$  to  $T_{MIN}$ , unless otherwise noted. Operating temperature range is  $-40^\circ\text{C}$  to  $+105^\circ\text{C}$ .

Table 2.

Parameter	Limit at $T_{MIN}$ to $T_{MAX}$	Unit	Description
$t_1$	20	ns min	LE setup time
$t_2$	10	ns min	DATA to CLK setup time
$t_3$	10	ns min	DATA to CLK hold time
$t_4$	25	ns min	CLK high duration
$t_5$	25	ns min	CLK low duration
$t_6$	10	ns min	CLK to LE setup time
$t_7$	20	ns min	LE pulse width
$t_8$	10	ns max	LE setup time to DOUT
$t_9$	15	ns max	CLK setup time to DOUT

**Timing Diagrams**

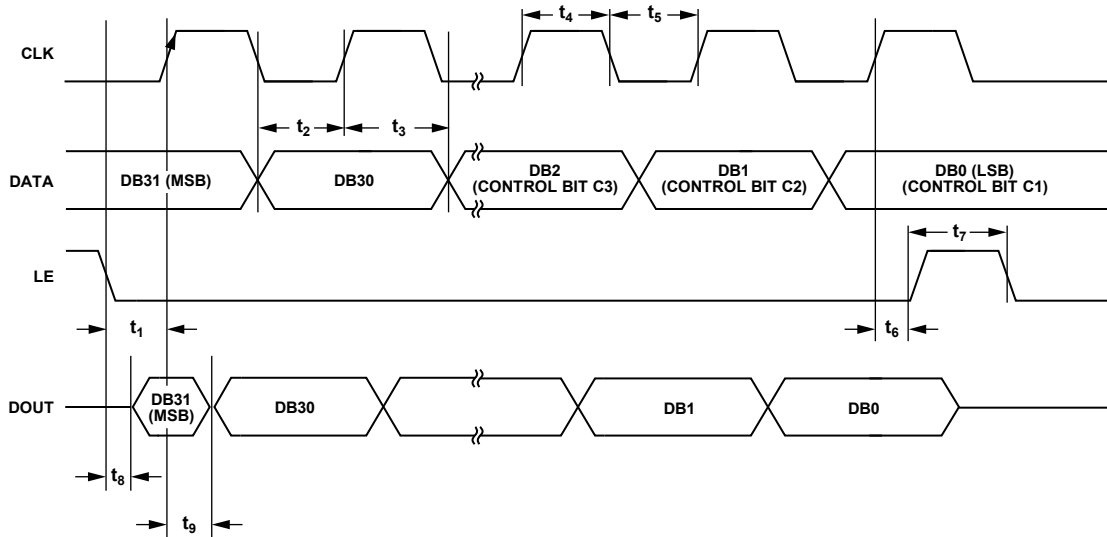

12885-002

Figure 2. Timing Diagram

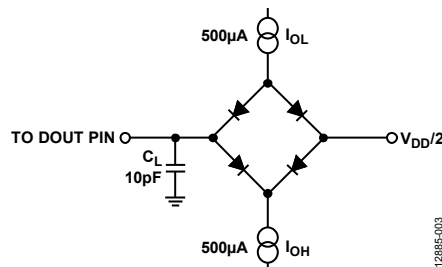

12885-003

Figure 3. Load Circuit for DOUT Timing,  $C_L = 10\text{ pF}$

## ABSOLUTE MAXIMUM RATINGS

$T_A = 25^\circ\text{C}$ , unless otherwise noted.

**Table 3.**

Parameter	Rating
$AV_{DD}$ to GND	-0.3 V to +3.9 V
Digital Input/Output Voltage to GND	-0.3 V to $AV_{DD} + 0.3$ V
Analog Input/Output Voltage to GND	-0.3 V to $AV_{DD} + 0.3$ V
RXX_RF, LO_IN to GND	-0.3 V to $AV_{DD} + 0.3$ V
Operating Temperature Range	-40°C to +105°C
Storage Temperature Range	-65°C to +125°C
Maximum Junction Temperature	150°C
$\theta_{JA}$ Thermal Impedance <sup>1</sup> (Pad Soldered)	40.83°C/W
Reflow Soldering	
Peak Temperature	260°C
Time at Peak Temperature	40 sec
Transistor Count	
CMOS	65,100
Bipolar	2280
ESD	
CDM	500 V
HBM	2000 V

<sup>1</sup> Two signal planes (that is, on the top and the bottom surfaces of the board), two buried planes, and nine vias.

Stresses at or above those listed under Absolute Maximum Ratings may cause permanent damage to the product. This is a stress rating only; functional operation of the product at these or any other conditions above those indicated in the operational section of this specification is not implied. Operation beyond the maximum operating conditions for extended periods may affect product reliability.

### ESD CAUTION



**ESD (electrostatic discharge) sensitive device.** Charged devices and circuit boards can discharge without detection. Although this product features patented or proprietary protection circuitry, damage may occur on devices subjected to high energy ESD. Therefore, proper ESD precautions should be taken to avoid performance degradation or loss of functionality.

## PIN CONFIGURATION AND FUNCTION DESCRIPTIONS

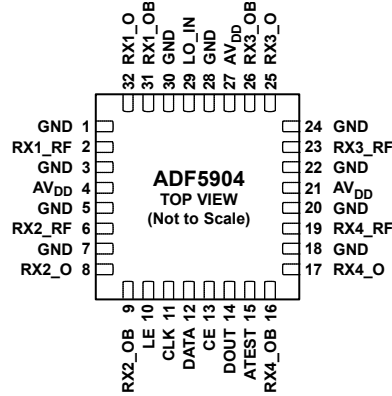

**NOTES**  
 1. THE LFCSP HAS AN EXPOSED PAD THAT MUST BE CONNECTED TO GND.

12885F-004

Figure 4. Pin Configuration

Table 4. Pin Function Descriptions

Pin No.	Mnemonic	Description
1, 3, 5, 7, 18, 20, 22, 24, 28, 30	GND	Ground Pins.
2	RX1_RF	Channel 1 RF Input.
4, 21, 27	AV <sub>DD</sub>	Analog Power Supply. The supply range is 3.3 V ± 5%. Place decoupling capacitors (0.1 μF, 1 nF, and 10 pF) to the ground plane as close as possible to this pin.
6	RX2_RF	Channel 2 RF Input.
8	RX2_O	Channel 2 Baseband Output.
9	RX2_OB	Channel 2 Complementary Baseband Output.
10	LE	Load Enable, CMOS Input. When LE goes high, data stored in the shift registers is loaded into one of the four latches; the control bits select the latch.
11	CLK	Serial Clock Input. This serial clock clocks in the serial data to the registers. Data latches into the 32-bit shift register on the CLK rising edge. This input is a high impedance CMOS input.
12	DATA	Serial Data Input. The serial data loads MSB first and the two LSBs are the control bits. This input is a high impedance CMOS input.
13	CE	Chip Enable. A logic low on this pin powers down the device.
14	DOUT	Serial Data Output.
15	ATEST	Analog Test Output
16	RX4_OB	Channel 4 Complementary Baseband Output.
17	RX4_O	Channel 4 Baseband Output.
19	RX4_RF	Channel 4 RF Input.
23	RX3_RF	Channel 3 RF Input.
25	RX3_O	Channel 3 Baseband Output.
26	RX3_OB	Channel 3 Complementary Baseband Output.
29	LO_IN	Local Oscillator Input.
31	RX1_OB	Channel 1 Complementary Baseband Output.
32	RX1_O	Channel 1 Baseband Output.
	EPAD	Exposed Pad. The LFCSP has an exposed pad that must connect to GND.

### TYPICAL PERFORMANCE CHARACTERISTICS

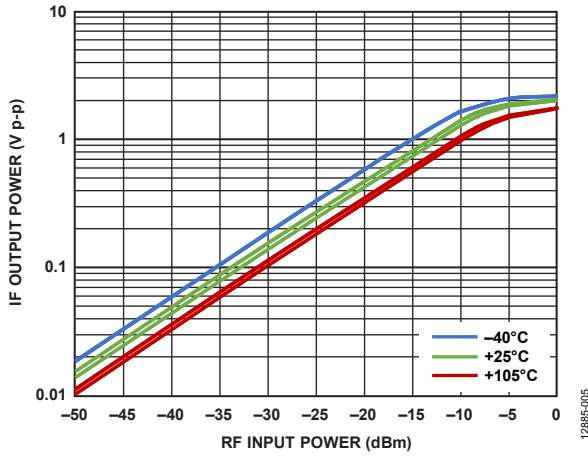

Figure 5. IF Output Power vs. RF Input Power, LO Frequency = 24 GHz at -5 dBm and IF Frequency = 100 kHz

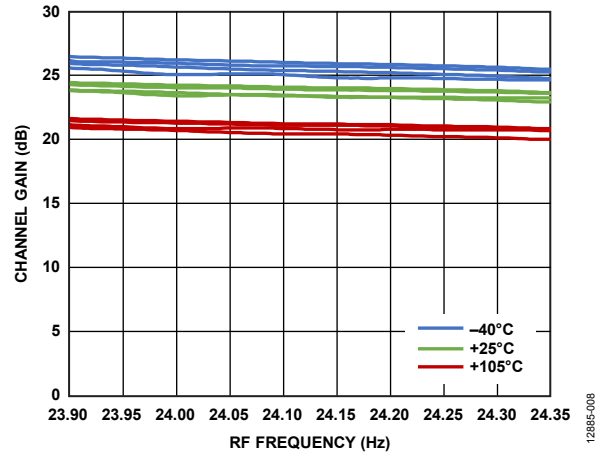

Figure 8. Channel Gain vs. RF Frequency, Rx Input = -50 dBm, LO Power = -5 dBm, and IF Frequency = 100 kHz

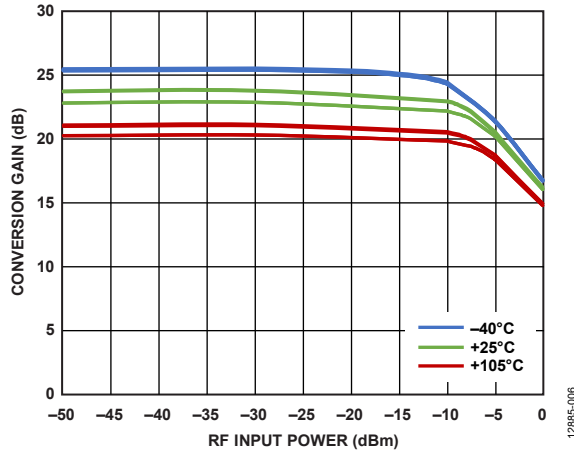

Figure 6. Conversion Gain vs. RF Input Power, LO Frequency = 24 GHz at -5 dBm, and IF Frequency = 100 kHz

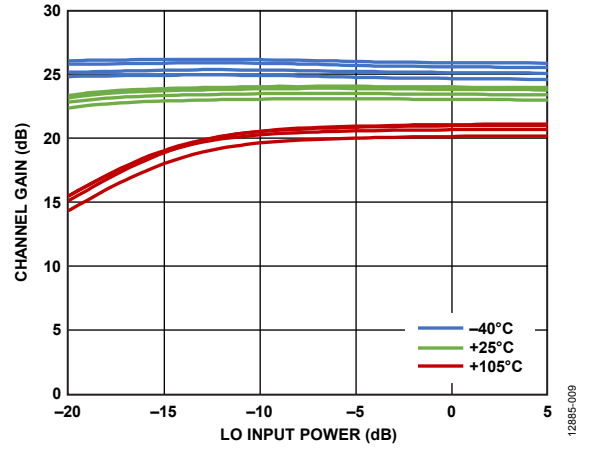

Figure 9. Channel Gain vs. LO Input Power, Rx Input = -50 dBm, LO Frequency = 24 GHz, and IF Frequency = 100 kHz

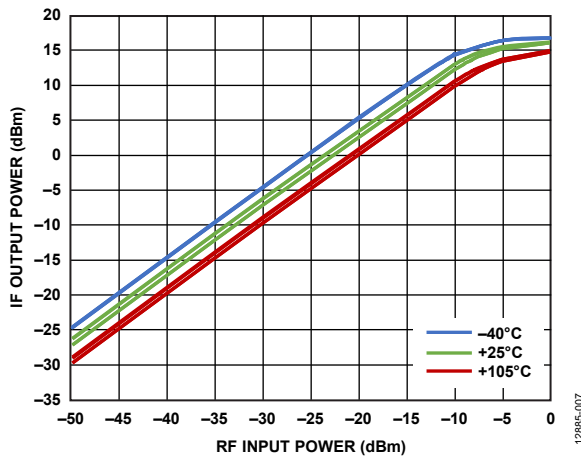

Figure 7. IF Output Power vs. RF Input Power, LO Frequency = 24 GHz at -5 dBm, and IF Frequency = 100 kHz

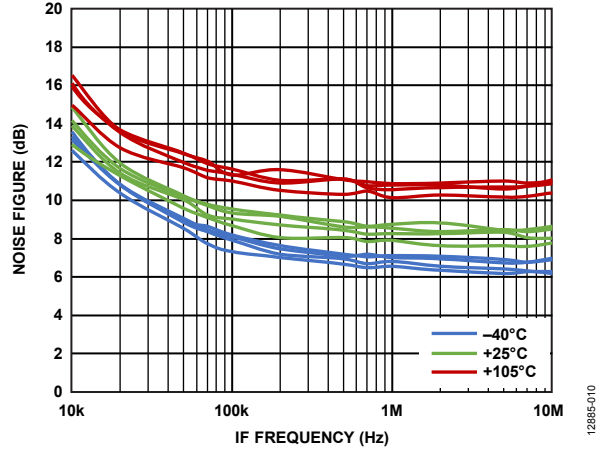

Figure 10. Noise Figure vs. IF Frequency, LO Frequency = 24.125 GHz at -5 dBm

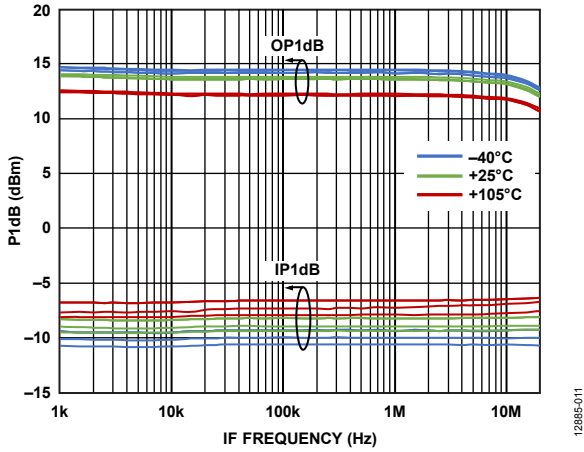

Figure 11. P1dB vs. IF Frequency, LO Frequency = 24 GHz at -5 dBm

12885-011

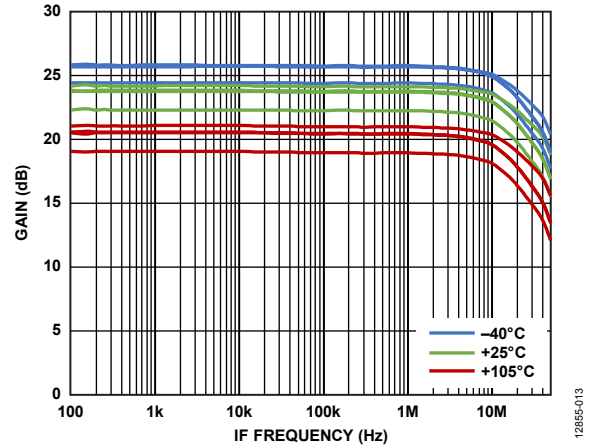

Figure 13. Gain vs. IF Frequency, Rx Power = -50 dBm and LO Frequency = 24 GHz at -5 dBm

12885-013

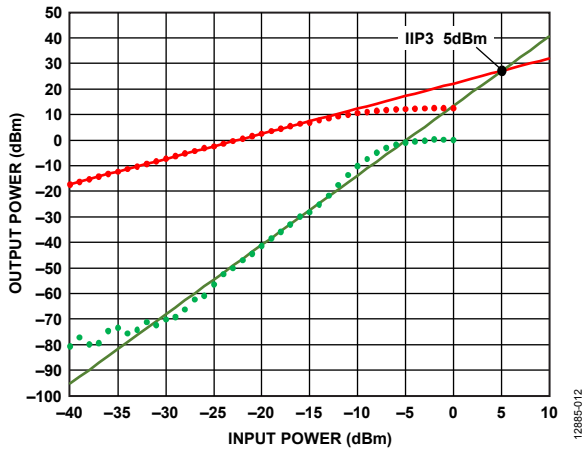

Figure 12. Output Power vs. Input Power, IIP3 LO Frequency = 24.125 GHz at -5 dBm, Rx Frequency = LO + 100 kHz and LO + 200 kHz

12885-012

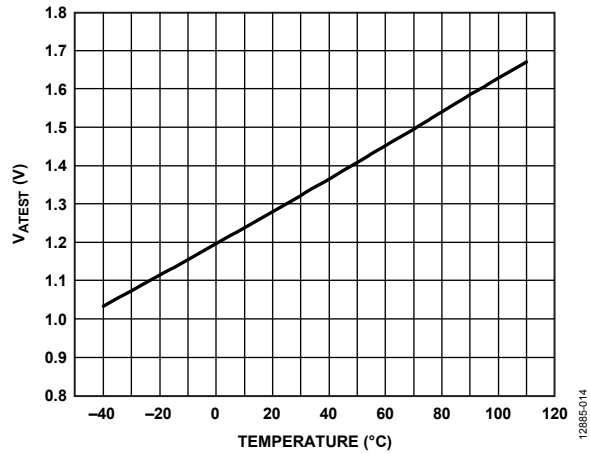

Figure 14. Temperature Sensor Voltage on ATEST

12885-014

# THEORY OF OPERATION

## RF PATH

The ADF5904 contains four identical 24 GHz downconverter channels. Each channel contains a balun that converts the single-ended input into a differential signal for the rest of the downconverter path (see Figure 15). This balun is followed by a LNA that feeds the downconverter mixer.

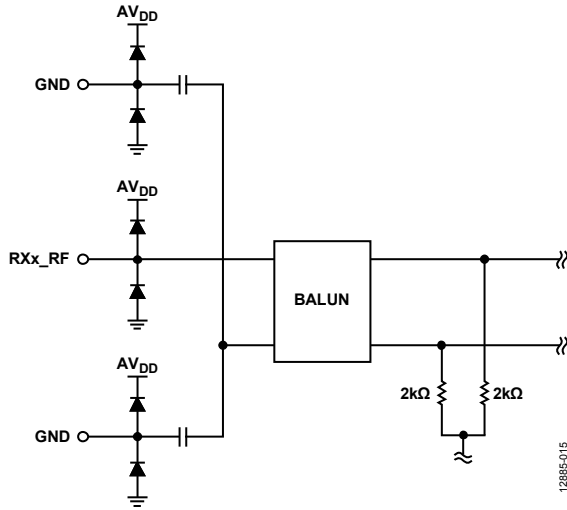

Figure 15. RF Input Stage

## LO PATH

The four downconverter channels share the same LO path. The LO path contains a balun that converts the single-ended input to a differential signal to drive the mixer (see Figure 16).

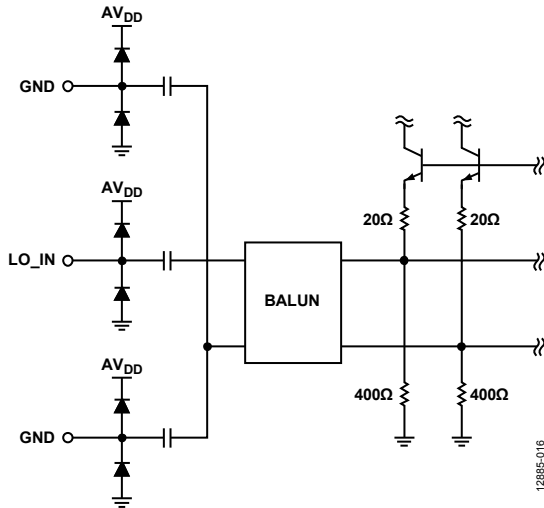

Figure 16. LO Input Stage

## INPUT SHIFT REGISTER

The ADF5904 digital section includes power-down bits and test modes to read back registers. Data is clocked into the 32-bit input shift register on each rising edge of CLK. The data is clocked in MSB first. Data is transferred from the input shift register to one of four latches on the rising edge of LE. The destination latch is determined by the state of the two control bits (C2 and C1) in the input shift register. These are the two LSBs (DB1 and DB0, respectively), as shown in Table 5. The truth table for these bits is shown in Table 5. Figure 18 to Figure 20 show a summary of how the latches are programmed.

## PROGRAM MODES

Table 5 and Figure 18 through Figure 20 show how to set up the program modes in the ADF5904.

Table 5. C2 and C1 Truth Table

Control Bits		Register
C2 (DB1)	C1 (DB0)	
0	0	R0
0	1	R1
1	0	R2
1	1	R3

REGISTER MAP

REGISTER 0 (R0)

RESERVED																PUP CH4	PUP CH3	PUP CH2	PUP CH1	PUP LO	LO PIN BIAS	DOUT VSEL	RESERVED						CONTROL BITS		
DB31	DB30	DB29	DB28	DB27	DB26	DB25	DB24	DB23	DB22	DB21	DB20	DB19	DB18	DB17	DB16	DB15	DB14	DB13	DB12	DB11	DB10	DB9	DB8	DB7	DB6	DB5	DB4	DB3	DB2	DB1	DB0
1	0	0	0	0	0	0	0	0	0	0	0	0	0	0	0	0	PC4	PC3	PC2	PC1	PLO	LPB	DIO	1	0	1	0	0	0	C2(0)	C1(0)

REGISTER 1 (R1)

CHANNEL SELECT		RESERVED																								CONTROL BITS					
DB31	DB30	DB29	DB28	DB27	DB26	DB25	DB24	DB23	DB22	DB21	DB20	DB19	DB18	DB17	DB16	DB15	DB14	DB13	DB12	DB11	DB10	DB9	DB8	DB7	DB6	DB5	DB4	DB3	DB2	DB1	DB0
CS2	CS1	CS0	0	0	0	0	0	0	0	0	0	0	0	0	0	0	0	0	1	0	1	0	0	1	0	0	1	1	0	C2(0)	C1(1)

REGISTER 2 (R2)

RESERVED																5-BIT CHANNEL TEST SELECT					RESERVED						CONTROL BITS					
DB31	DB30	DB29	DB28	DB27	DB26	DB25	DB24	DB23	DB22	DB21	DB20	DB19	DB18	DB17	DB16	DB15	DB14	DB13	DB12	DB11	DB10	DB9	DB8	DB7	DB6	DB5	DB4	DB3	DB2	DB1	DB0	
0	0	0	0	0	0	0	0	0	0	0	0	0	0	0	1	0	0	TC4	TC3	TC2	TC1	TC0	0	0	0	0	0	0	0	1	C2(1)	C1(0)

REGISTER 3 (R3)

RESERVED																										CONTROL BITS					
DB31	DB30	DB29	DB28	DB27	DB26	DB25	DB24	DB23	DB22	DB21	DB20	DB19	DB18	DB17	DB16	DB15	DB14	DB13	DB12	DB11	DB10	DB9	DB8	DB7	DB6	DB5	DB4	DB3	DB2	DB1	DB0
0	0	0	0	0	0	0	0	0	0	0	0	0	0	0	0	0	0	0	0	0	0	0	0	0	0	0	0	0	0	C2(1)	C1(1)

Figure 17. Latch Summary

12895-017

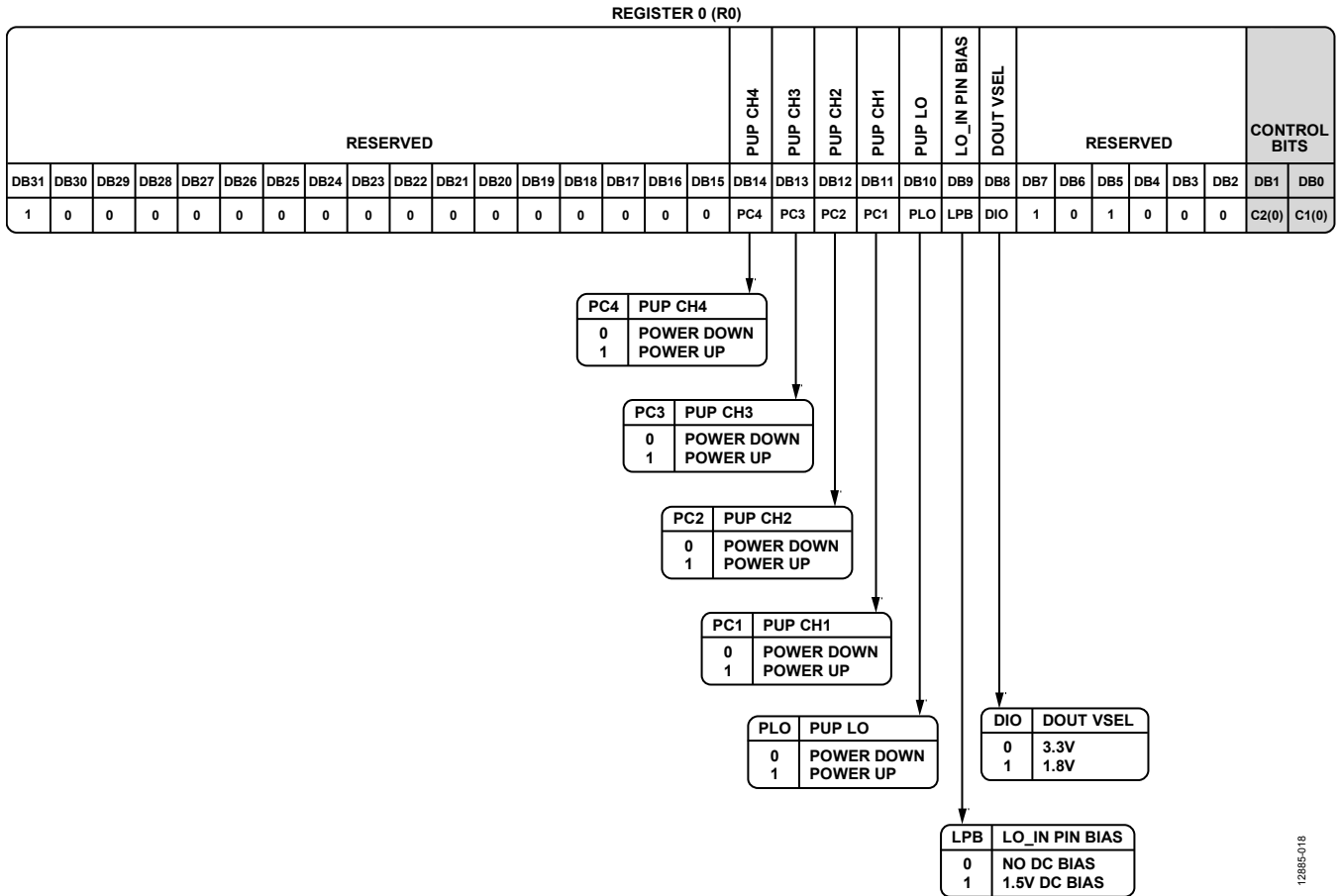

Figure 18. Register 0

12895-018

**REGISTER 0**

**Register 0 Control Bits**

With Bits[C2:C1] set to 00, Register R0 is programmed. Figure 18 shows the input data format for programming this register.

**DOUT VSEL**

DB8 controls the DOUT logic levels. Set this bit to 0 to set the DOUT logic level to 3.3 V, and set this bit to 1 to sets the DOUT logic level to 1.8 V.

**LO\_IN Pin Bias**

DB9 controls the dc bias voltage on the LO\_IN pin (Pin 29). Set this bit to 0 to set no dc bias on the LO\_IN pin, and set this bit to 1 to set the dc bias to 1.5 V. AC couple the LO signal to the LO\_IN pin.

**PUP LO**

DB10 provides the power-up bit for the LO block. Set this bit to 0 to power down the LO block, and set this bit to 1 to return the LO block to normal operation.

**PUP CH1**

DB11 provides the power-up bit for RF Receiver Channel 1. Setting this bit to 0 performs a power-down of Channel 1 blocks. Setting this bit to 1 returns Channel 1 blocks to normal operation.

**PUP CH2**

DB12 provides the power-up bit for RF Receiver Channel 2. Set this bit to 0 to power down the Channel 2 blocks, and set this bit to 1 to return the Channel 2 blocks to normal operation.

**PUP CH3**

DB13 provides the power-up bit for RF Receiver Channel 3. Set this bit to 0 to power down the Channel 3 blocks, and set this bit to 1 to return the Channel 3 blocks to normal operation.

**PUP CH4**

DB14 provides the power-up bit for RF Receiver Channel 4. Set this bit to 0 to power down the Channel 4 blocks, and set this bit to 1 to return the Channel 4 blocks to normal operation.

REGISTER 1 (R1)

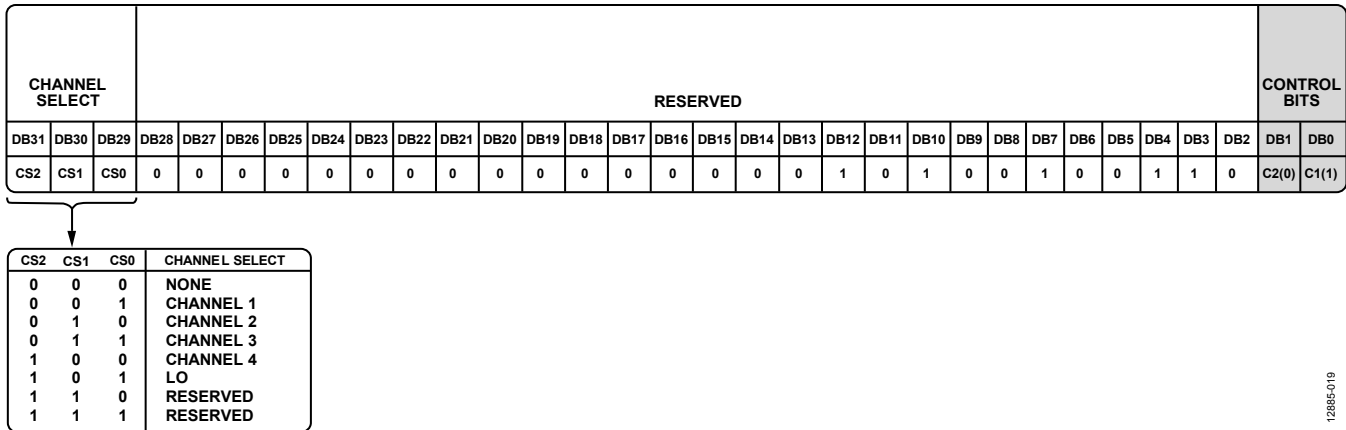

Figure 19. Register 1

REGISTER 2 (R2)

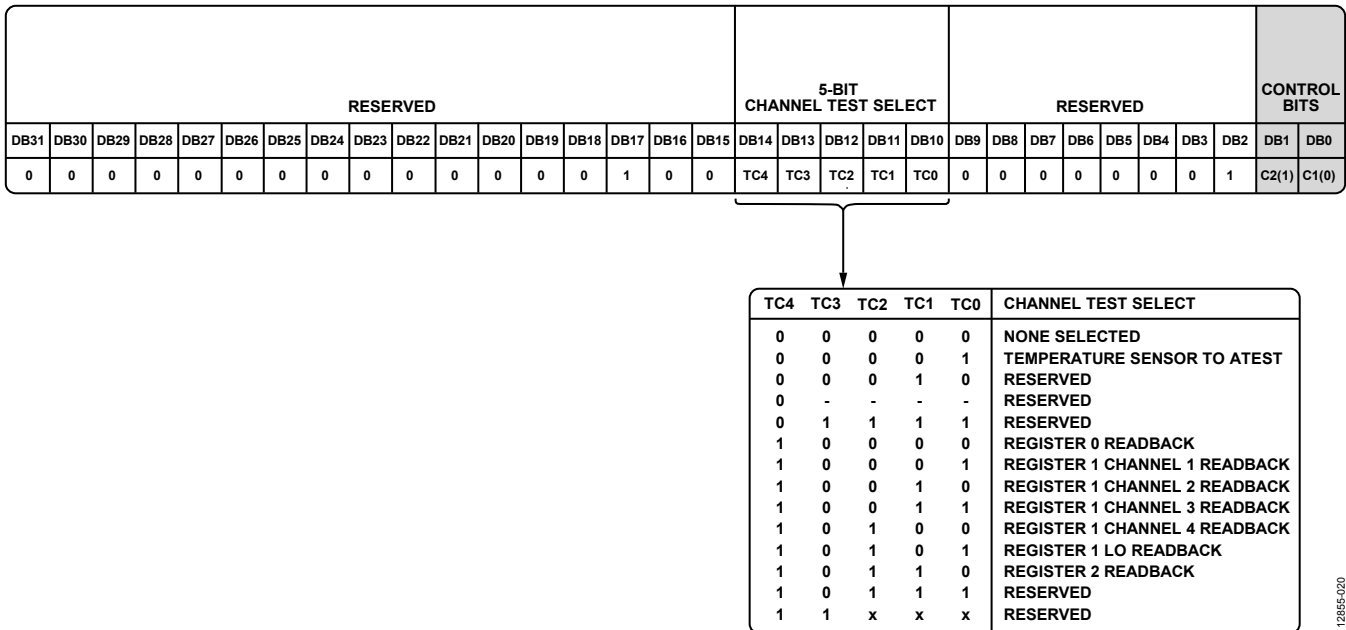

Figure 20. Register 2

**REGISTER 1**

**Register 1 Control Bits**

With Bits[C2:C1] set to 01, Register R1 is programmed. Register 1 contains the internal controls for the four RF channels and the LO path. During the initialization sequence, the default conditions are loaded. See Step 3 to Step 7 in Table 6.

**REGISTER 2**

**Register 2 Control Bits**

With Bits[C2:C1] set to 10, Register R2 is programmed. Figure 20 shows the input data format for programming this register.

**5-Bit Channel Test Select**

Bits[DB14:DB10] control the ADF5904 test modes. These bits allow access to the temperature sensor on the ATEST pin and the register readback on the DOUT pin. See Figure 20 for the truth table.

## INITIALIZATION SEQUENCE

After powering up the device, administer the initialization sequence in Table 6 to set the register with the code to configure the device.

**Table 6. Initialization Sequence**

Step	Register	Hex Code	Description
1	R3	0x00000003	Reserved
2	R2	0x00020406	Temperature sensor to ATEST
3	R1	0x20001499	Configure Channel 1
4	R1	0x40001499	Configure Channel 2
5	R1	0x60001499	Configure Channel 3
6	R1	0x80001499	Configure Channel 4
7	R1	0xA0000019	Configure LO
8	R0	0x80007CA0	Power up

## TEMPERATURE SENSOR

The on-chip temperature sensor of the [ADF5904](#) is accessed on the ATEST pin. The temperature sensor operates over the full operating temperature range of  $-40^{\circ}\text{C}$  to  $+105^{\circ}\text{C}$ . To improve accuracy, conduct a one-point calibration at room temperature and store the result in the external memory. Convert the ATEST voltage to temperature by using the following equation:

$$\text{Temperature } (^{\circ}\text{C}) = (V_{\text{ATEST}} - V_{\text{OFF}})/V_{\text{GAIN}}$$

where:

$V_{\text{ATEST}}$  is the voltage on the ATEST pin.

$V_{\text{OFF}}$  is the offset voltage and it is 1.212 V.

$V_{\text{GAIN}}$  is the voltage gain and it is  $4.072e^{-3}$ .

## APPLICATION INFORMATION

### APPLICATION OF THE ADF5904 IN FMCW RADAR

Figure 21 shows the application of the ADF5904 in a frequency modulated continuous wave (FMCW) radar system.

In the FMCW radar system, the ADF4159 generates the sawtooth or triangle ramps necessary for this type of radar to operate.

The ADF4159 controls the VTUNE pin on the transceiver (Tx) monolithic microwave integrated circuit (MMIC) and thus the frequency of the voltage controlled oscillator (VCO) and the Tx output signal on TXOUT1 or TXOUT2. The LO signal from the Tx MMIC is fed to the LO input on the ADF5904.

The ADF5904 downconverts the signal from the four receiver antennas to baseband with the LO signal from the Tx MMIC.

The downconverted baseband signals from the four receiver channels on the ADF5904 are fed to the ADAR7251 4-channel, continuous time (CT), sigma-delta ( $\Sigma$ - $\Delta$ ) analog-to-digital converter (ADC).

A digital signal processor (DSP) follows the ADC to handle the target information processing.

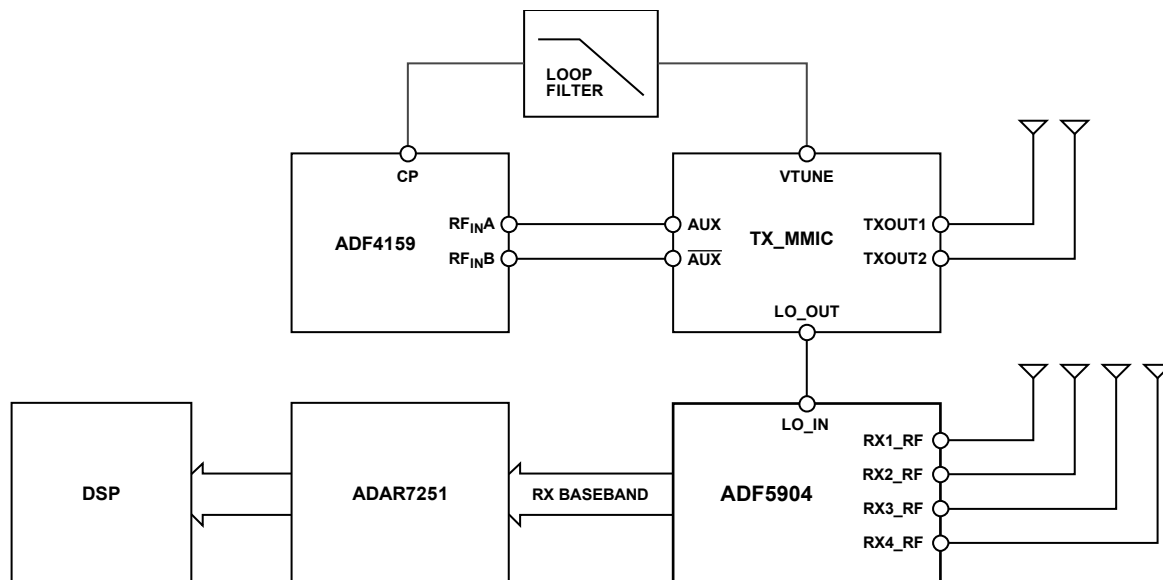
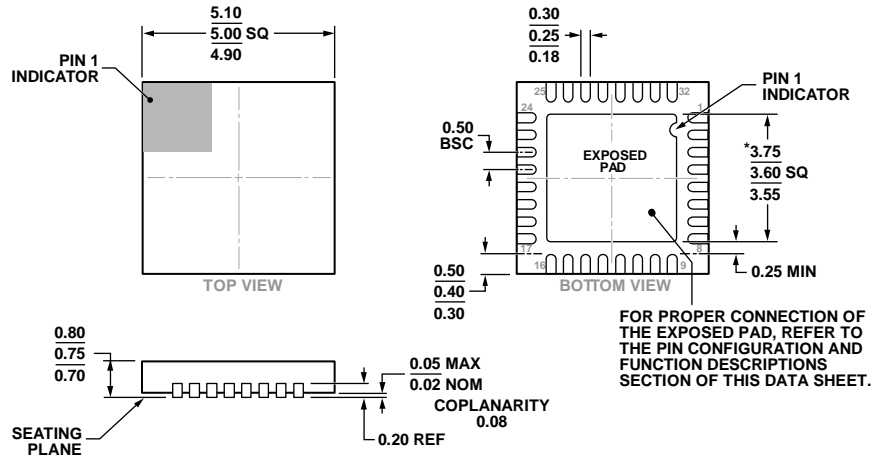

Figure 21. FMCW Radar with ADF5904

12885-021

### OUTLINE DIMENSIONS



\*COMPLIANT TO JEDEC STANDARDS MO-220-WHHD-5 WITH THE EXCEPTION OF THE EXPOSED PAD DIMENSION.

Figure 22. 32-Lead Lead Frame Chip Scale Package [LFCSP\_WQ]  
 5 mm × 5mm Body, Very Very Thin Quad  
 (CP-32-12)  
 Dimensions shown in millimeters

08-16-2010-B

### ORDERING GUIDE

Model <sup>1,2</sup>	Temperature Range	Package Description	Package Option
ADF5904WCCPZ	-40°C to +105°C	32-Lead Lead Frame Chip Scale Package [LFCSP_WQ]	CP-32-12
ADF5904WCCPZ-RL7	-40°C to +105°C	32-Lead Lead Frame Chip Scale Package [LFCSP_WQ]	CP-32-12
ADF5904ACPZ	-40°C to +105°C	32-Lead Lead Frame Chip Scale Package [LFCSP_WQ]	CP-32-12
ADF5904ACPZ-RL7	-40°C to +105°C	32-Lead Lead Frame Chip Scale Package [LFCSP_WQ]	CP-32-12
EV-ADF5904SD2Z		Evaluation Board	

<sup>1</sup> Z = RoHS Compliant Part.

<sup>2</sup> W = Qualified for Automotive Applications.

### AUTOMOTIVE PRODUCTS

The [ADF5904W](#) models are available with controlled manufacturing to support the quality and reliability requirements of automotive applications. Note that these automotive models may have specifications that differ from the commercial models; therefore, designers should review the Specifications section of this data sheet carefully. Only the automotive grade products shown are available for use in automotive applications. Contact your local Analog Devices account representative for specific product ordering information and to obtain the specific Automotive Reliability reports for these models.

## Looking for pricing, stock, or lifecycle information?

Click below to explore more details on WIN SOURCE:

- ⊖ [View ADF5904WCCPZ-RL7 on WIN SOURCE](#)
- ⊖ [Analog Devices Inc. Information](#)

## Optimize Your Supply Chain with WIN SOURCE Solutions

- ✓ Global Sourcing Solution
- ✓ Obsolete Management
- ✓ Cost Control Management
- ✓ Shortage Management
- ✓ Alternative Solution
- ✓ Excess Inventory Management