



**THE DATASHEET OF  
AD5535ABCZ**



### FEATURES

- High integration**  
32-channel, 14-bit DAC with integrated high voltage output amplifier
- Guaranteed monotonic**
- Housed in 15 mm × 15 mm CSP\_BGA package**
- Full-scale output voltage**  
Programmable from 50 V to 200 V via reference input
- 700 μA drive capability**
- Integrated silicon diode for temperature monitoring**
- DSP-/microcontroller-compatible serial interface**
- 1.2 MHz channel update rate**
- Asynchronous RESET facility**
- 10°C to +85°C temperature range**

### APPLICATIONS

- Optical micro-electromechanical systems (MEMS)
- Optical crosspoint switches
- Micropositioning applications using piezoelectric actuators
- Level setting in automotive test and measurement

### GENERAL DESCRIPTION

The AD5535 is a 32-channel, 14-bit DAC with an on-chip high voltage output amplifier. This device is targeted for optical micro-electromechanical systems. The output voltage range is programmable via the REF\_IN pin. The output range is 0 V to 50 V when REF\_IN = 1 V, and 0 V to 200 V when REF\_IN = 4 V. Each amplifier can source 700 μA, which is ideal for the deflection and control of optical MEMS mirrors.

The selected DAC register is written to via the 3-wire interface. The serial interface operates at clock rates of up to 30 MHz and is compatible with DSP and microcontroller interface standards.

The device is operated with AV<sub>CC</sub> = 4.75 V to 5.25 V, DV<sub>CC</sub> = 2.7 V to 5.25 V, V<sub>-</sub> = -4.75 V to -5.25 V, V<sub>+</sub> = 4.75 V to 5.25 V, and V<sub>PP</sub> = 210 V. REF\_IN is buffered internally on the AD5535 and should be driven from a stable reference source.

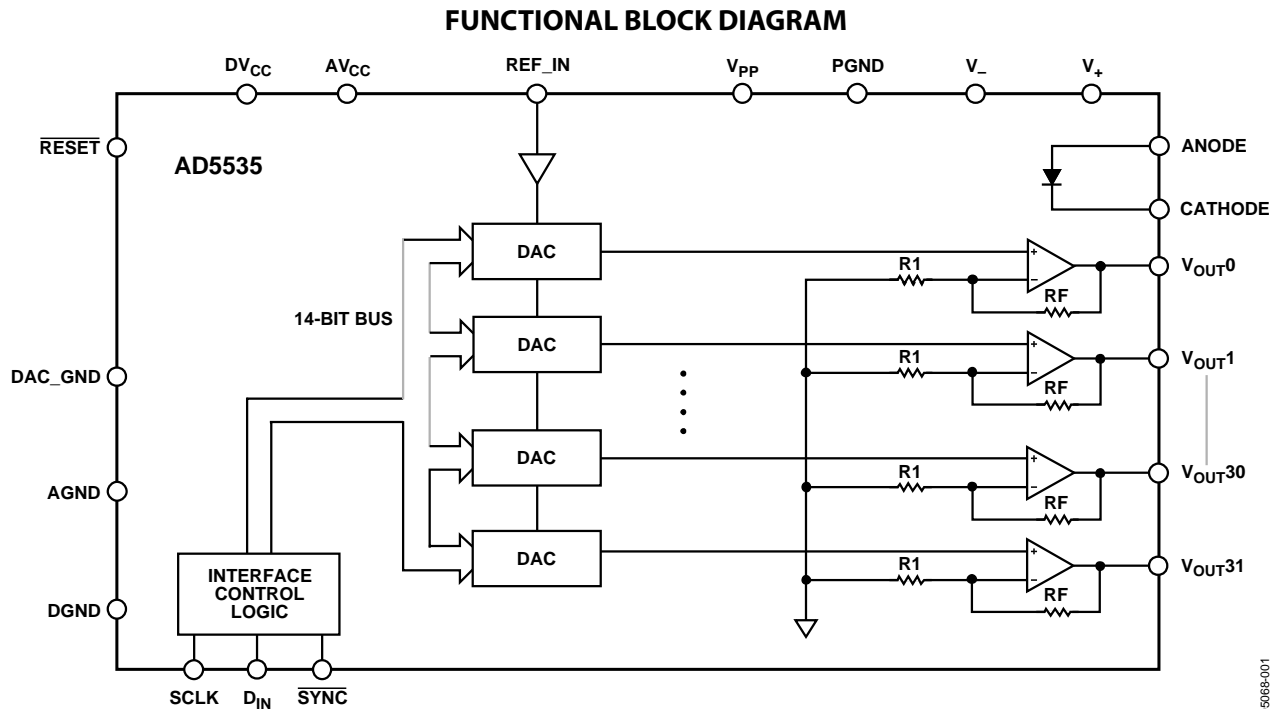

Figure 1.

09088-001

#### Rev. A

Information furnished by Analog Devices is believed to be accurate and reliable. However, no responsibility is assumed by Analog Devices for its use, nor for any infringements of patents or other rights of third parties that may result from its use. Specifications subject to change without notice. No license is granted by implication or otherwise under any patent or patent rights of Analog Devices. Trademarks and registered trademarks are the property of their respective owners.

## TABLE OF CONTENTS

Features .....	1	Reset Function .....	12
Applications.....	1	Serial Interface .....	12
General Description .....	1	Microprocessor Interfacing.....	12
Functional Block Diagram .....	1	Applications.....	14
Specifications.....	3	MEMS Mirror Control Application.....	14
Timing Characteristics .....	5	IPC-221-Compliant Board Layout.....	14
Absolute Maximum Ratings.....	6	Power Supply Sequencing and Decoupling Recommendations.....	15
ESD Caution.....	6	Guidelines for Printed Circuit Board Layout .....	15
Pin Configuration and Function Descriptions.....	7	Outline Dimensions .....	16
Typical Performance Characteristics .....	9	Ordering Guide .....	16
Terminology .....	11		
Functional Description .....	12		
DAC Section.....	12		

## REVISION HISTORY

### 8/05—Rev. 0 to Rev. A

Changes to Table 3.....	6
Changes to Ordering Guide .....	16

### 5/05—Revision 0: Initial Version

## SPECIFICATIONS

$V_{PP} = 210\text{ V}$ ,  $V_- = -5\text{ V}$ ,  $V_+ = +5\text{ V}$ ;  $AV_{CC} = 5.25\text{ V}$ ;  $DV_{CC} = 2.7\text{ V}$  to  $5.25\text{ V}$ ;  $PGND = AGND = DGND = DAC\_GND = 0\text{ V}$ ;  $REF\_IN = 4.096\text{ V}$ ; all outputs unloaded. All specifications  $T_{MIN}$  to  $T_{MAX}$ , unless otherwise noted.

**Table 1.**

Parameter <sup>1</sup>	A Grade <sup>2</sup>			Unit	Conditions/Comments
	Min	Typ	Max		
<b>DC PERFORMANCE<sup>3</sup></b>					
Resolution		14		Bits	Guaranteed monotonic
Integral Nonlinearity (INL)		$\pm 0.1$		% of FSR	
Differential Nonlinearity (DNL)	-1	$\pm 0.5$	+1	LSB	
Zero-Code Voltage		1	2.5	V	
Output Offset Error	-2		+2	V	
Offset Drift		0.02		mV/°C	
Voltage Gain	47.5	50	52.5	V/V	
Gain Temperature Coefficient		5		ppm/°C	
Channel-to-Channel Gain Match <sup>4</sup>	-5		+5	%	
Full-Scale Voltage Drift		3		ppm/°C	
<b>OUTPUT CHARACTERISTICS</b>					
Output Voltage Range <sup>3</sup>	2.5		$V_{PP} - 10$	V	
Output Impedance		50		$\Omega$	
Resistive Load <sup>4, 5</sup>	1			M $\Omega$	
Capacitive Load <sup>4</sup>			200	pF	
Short-Circuit Current		0.7		mA	
DC Crosstalk <sup>4</sup>			3	LSB	
DC Power Supply Rejection (PSRR), $V_{PP}$		70		dB	
<b>AC CHARACTERISTICS<sup>4</sup></b>					
Settling Time					No load 200 pF load No load 200 pF load No load 200 pF load Measured at 10 kHz 1 LSB change around major carry
$\frac{1}{4}$ to $\frac{3}{4}$ Scale Step		30		$\mu\text{s}$	
		65		$\mu\text{s}$	
1 LSB Step		10		$\mu\text{s}$	
		10		$\mu\text{s}$	
Slew Rate		10		V/ $\mu\text{s}$	
		3		V/ $\mu\text{s}$	
-3 dB Bandwidth	5			kHz	
Output Noise Spectral Density		4.5		$\mu\text{V}/\sqrt{\text{Hz}}$	
0.1 Hz to 10 Hz Output Noise Voltage		1		mV p-p	
Digital-to-Analog Glitch Impulse		10		nV-s	
Analog Crosstalk		13		$\mu\text{V}$ -s	
Digital Feedthrough		1		nV-s	
<b>VOLTAGE REFERENCE, REF_IN<sup>6</sup></b>					
Input Voltage Range <sup>4</sup>	1		4.096	V	AV <sub>CC</sub> must exceed REF_IN by 1.15 V min
Input Current			1.25	$\mu\text{A}$	
<b>TEMPERATURE MEASUREMENT DIODE<sup>4</sup></b>					
Peak Inverse Voltage, $P_{IV}$			5	V	Cathode to anode
Forward Diode Drop, $V_F$		0.65	0.8	V	$I_F = 100\ \mu\text{A}$ , anode to cathode
Forward Diode Current, $I_F$			100	$\mu\text{A}$	Anode to cathode
$V_F$ Temperature Coefficient, $T_C$		-2.20		mV/°C	Anode to cathode

# AD5535

Parameter <sup>1</sup>	A Grade <sup>2</sup>			Unit	Conditions/Comments
	Min	Typ	Max		
<b>DIGITAL INPUTS<sup>4</sup></b>					
Input Current		±5	±10	μA	
Input Low Voltage			0.8	V	
Input High Voltage	2.0			V	
Input Hysteresis (SCLK and SYNC Only)		200		mV	
Input Capacitance			10	pF	
<b>POWER SUPPLY VOLTAGES<sup>7</sup></b>					
V <sub>PP</sub>	(50 × REF_IN) + 10		225	V	
V <sub>-</sub>	-5.25		-4.75	V	
V <sub>+</sub>	4.75		5.25	V	
AV <sub>CC</sub>	4.75		5.25	V	
DV <sub>CC</sub>	2.7		5.25	V	
<b>POWER SUPPLY CURRENTS<sup>7</sup></b>					
I <sub>PP</sub>		75	100	μA/channel	
I <sub>-</sub>		2.3	3.5	mA	
I <sub>+</sub>		0.5	1	mA	
AI <sub>CC</sub>		15	18	mA	
DI <sub>CC</sub>		0.25	0.5	mA	
<b>POWER DISSIPATION<sup>7</sup></b>					
		594		mW	

<sup>1</sup> See the Terminology section.

<sup>2</sup> A Grade temperature range: -10°C to +85°C; typical = +25°C.

<sup>3</sup> Linear output voltage range: +7 V to V<sub>PP</sub> - 10 V.

<sup>4</sup> Guaranteed by design and characterization, not production tested.

<sup>5</sup> Ensure that T<sub>J</sub> max is not exceeded. See the Absolute Maximum Ratings section.

<sup>6</sup> Reference input determines output voltage range. Using a 4.096 V reference (REF198) gives an output voltage range of 2.50 V to 200 V. The output range is programmable via the reference input. The full-scale output range is programmable from 50 V to 200 V. The linear output voltage range is restricted from 7 V to V<sub>PP</sub> - 10 V.

<sup>7</sup> Outputs unloaded.

## TIMING CHARACTERISTICS

$V_{PP} = 210\text{ V}$ ,  $V_- = -5\text{ V}$ ,  $V_+ = +5\text{ V}$ ;  $AV_{CC} = 5.25\text{ V}$ ;  $DV_{CC} = 2.7\text{ V}$  to  $5.25\text{ V}$ ;  $AGND = DGND = DAC\_GND = 0\text{ V}$ ;  $REF\_IN = 4.096\text{ V}$ .  
All specifications  $T_{MIN}$  to  $T_{MAX}$ , unless otherwise noted.

Table 2.

Parameter <sup>1, 2, 3</sup>	A Grade	Unit	Conditions/Comments
$f_{UPDATE}$	1.2	MHz max	Channel Update Rate
$f_{CLKIN}$	30	MHz max	SCLK Frequency
$t_1$	13	ns min	SCLK High Pulse Width
$t_2$	13	ns min	SCLK Low Pulse Width
$t_3$	15	ns min	$\overline{SYNC}$ Falling Edge to SCLK Falling Edge Setup Time
$t_4$	50	ns min	$\overline{SYNC}$ Low Time
$t_5$	10	ns min	$\overline{SYNC}$ High Time
$t_6$	10	ns min	$D_{IN}$ Setup Time
$t_7$	5	ns min	$D_{IN}$ Hold Time
$t_8$	200	ns min	19 <sup>th</sup> SCLK Falling Edge to $\overline{SYNC}$ Falling Edge for Next Write
$t_9$	20	ns min	$\overline{RESET}$ Pulse Width

<sup>1</sup> See Figure 2.

<sup>2</sup> Guaranteed by design and characterization, not production tested.

<sup>3</sup> All input signals are specified with  $t_r = t_f = 5\text{ ns}$  (10% to 90% of  $DV_{CC}$ ) and timed from a voltage level of  $(V_{IL} + V_{IH})/2$ .

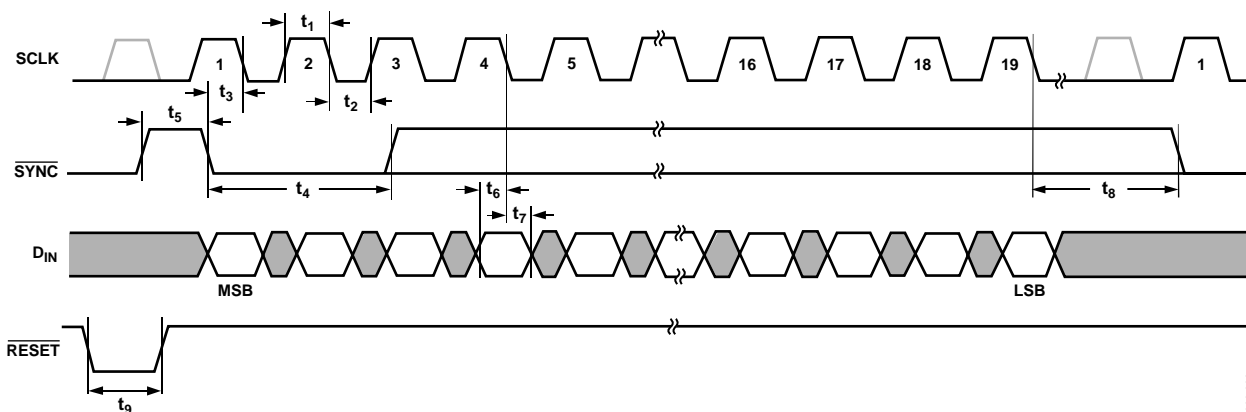

Figure 2. Serial Interface Timing Diagram

05068-012

## ABSOLUTE MAXIMUM RATINGS

$T_A = 25^\circ\text{C}$ , unless otherwise noted.

Table 3.

Parameter	Rating
$V_{PP}$ to AGND	0.3 V to 250 V
$V_-$ to AGND	+0.3 V to -6 V
$V_+$ to AGND	-0.3 V to +7 V
$AV_{CC}$ to AGND, DAC_GND	-0.3 V to +7 V
$DV_{CC}$ to DGND	-0.3 V to +7 V
Digital Inputs to DGND	-0.3 V to $DV_{CC} + 0.3$ V
REF_IN to AGND, DAC_GND	-0.3 V to $AV_{CC} + 0.3$ V
$V_{OUT}$ (0 to 31) to AGND	$V_-$ to $V_{PP}$
Anode/Cathode to AGND, DAC_GND	-0.3 V to +7 V
AGND to DGND	-0.3 V to +0.3 V
Operating Temperature Range	
Industrial	$-10^\circ\text{C}$ to $+85^\circ\text{C}$
Storage Temperature Range	$-65^\circ\text{C}$ to $+150^\circ\text{C}$
Junction Temperature ( $T_J$ max)	$150^\circ\text{C}$
124-Lead CSP_BGA Package, $\theta_{JA}$ Thermal Impedance	$40^\circ\text{C/W}$
Lead Temperature Soldering	
Vapor Phase (60 sec)	$215^\circ\text{C}$
Infrared (15 sec)	$220^\circ\text{C}$
Reflow Soldering (Pb-free)	
Peak Temperature	$260(0/-5)^\circ\text{C}$
Time at Peak Temperature	10 sec to 40 sec
ESD (Human Body Model)	450 V

Stresses above those listed under Absolute Maximum Ratings may cause permanent damage to the device. This is a stress rating only; functional operation of the device at these or any other conditions above those indicated in the operational section of this specification is not implied. Exposure to absolute maximum rating conditions for extended periods may affect device reliability.

Transient currents up to 100 mA do not cause SCR latch-up.

This device is an integrated high voltage circuit with an ESD rating of <2 kV, and it is ESD sensitive. Proper precautions should be taken for handling and assembly.

### ESD CAUTION

ESD (electrostatic discharge) sensitive device. Electrostatic charges as high as 4000 V readily accumulate on the human body and test equipment and can discharge without detection. Although this product features proprietary ESD protection circuitry, permanent damage may occur on devices subjected to high energy electrostatic discharges. Therefore, proper ESD precautions are recommended to avoid performance degradation or loss of functionality.



## PIN CONFIGURATION AND FUNCTION DESCRIPTIONS

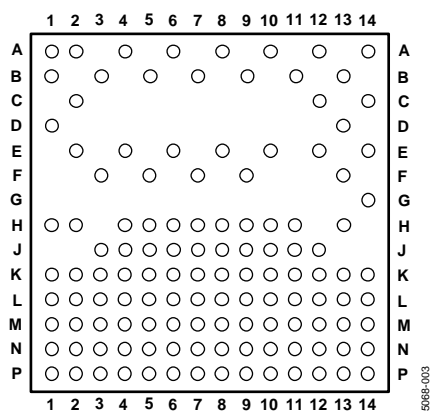

Figure 3. Pin Configuration

Table 4. 124-Lead CSP-BGA Ball Configuration

CSP_BGA No.	Ball Name	CSP_BGA No.	Ball Name	CSP_BGA No.	Ball Name	CSP_BGA No.	Ball Name
A1	NC	C14	V <sub>OUT29</sub>	H2	V <sub>PP</sub>	N2	PGND
A2	V <sub>OUT1</sub>	D1	V <sub>OUT2</sub>	H4 to H11	AGND	N3	CATHODE
A4	V <sub>OUT7</sub>	D13	V <sub>OUT23</sub>	H13	V <sub>OUT27</sub>	N4	ANODE
A6	V <sub>OUT11</sub>	E2	V <sub>OUT5</sub>	J3 to J12	AGND	N5 to N14	AGND
A8	V <sub>OUT16</sub>	E4	V <sub>OUT8</sub>	K1	V <sub>+</sub>	P1	NC
A10	V <sub>OUT20</sub>	E6	V <sub>OUT12</sub>	K2	V <sub>+</sub>	P2	REF_IN
A12	V <sub>OUT25</sub>	E8	V <sub>OUT15</sub>	K3 to K14	AGND	P3	DAC_GND
A14	NC	E10	V <sub>OUT19</sub>	L1	V <sub>-</sub>	P4	RESET
B1	V <sub>OUT0</sub>	E12	V <sub>OUT24</sub>	L2	V <sub>-</sub>	P5	DV <sub>CC</sub>
B3	V <sub>OUT4</sub>	E14	V <sub>OUT31</sub>	L3 to L13	AGND	P6	DGND
B5	V <sub>OUT9</sub>	F3	V <sub>OUT6</sub>	L14	DAC_GND	P7	TEST
B7	V <sub>OUT13</sub>	F5	V <sub>OUT10</sub>	M1	AGND	P8	D <sub>IN</sub>
B9	V <sub>OUT17</sub>	F7	V <sub>OUT14</sub>	M2	AGND	P9	SCLK
B11	V <sub>OUT21</sub>	F9	V <sub>OUT18</sub>	M3 to M12	AGND	P10	SYNC
B13	V <sub>OUT26</sub>	F13	V <sub>OUT30</sub>	M13	AV <sub>CC</sub>	P11 to P13	AGND
C2	V <sub>OUT3</sub>	G14	V <sub>OUT28</sub>	M14	AV <sub>CC</sub>	P14	NC
C12	V <sub>OUT22</sub>	H1	V <sub>PP</sub>	N1	PGND		

# AD5535

**Table 5. Pin Function Descriptions**

<b>Mnemonic</b>	<b>Description</b>
AGND	Analog GND Pins.
AV <sub>CC</sub>	Analog Supply Pins. Voltage range from 4.75 V to 5.25 V.
V <sub>PP</sub>	Output Amplifier High Voltage Supply. Voltage range from (REF_IN × 50) + 10 V to 225 V.
V <sub>+</sub>	V <sub>+</sub> Amplifier Supply Pins. Voltage range from 4.75 V to 5.25 V.
V <sub>-</sub>	V <sub>-</sub> Amplifier Supply Pins. Voltage range from -4.75 V to -5.25 V.
PGND	Output Amplifier Ground Reference Pins.
DGND	Digital GND Pins.
DV <sub>CC</sub>	Digital Supply Pins. Voltage range from 2.7 V to 5.25 V.
DAC_GND	Reference GND Supply for All DACs.
REF_IN	Reference Voltage for Channel 0 to Channel 31. Reference input range is 1 V to 4 V and can be used to program the full-scale output voltage from 50 V to 200 V.
V <sub>OUT0</sub> to V <sub>OUT31</sub>	Analog Output Voltages from the 32 Channels.
ANODE	Anode of Internal Diode for Diode Temperature Measurement.
CATHODE	Cathode of Internal Diode for Diode Temperature Measurement.
$\overline{\text{SYNC}}$	Active Low Input. This is the frame synchronization signal for the serial interface. While $\overline{\text{SYNC}}$ is low, data is transferred in upon the falling edge of SCLK.
SCLK <sup>1</sup>	Serial Clock Input. Data is clocked into the shift register upon the falling edge of SCLK. This operates at clock speeds of up to 30 MHz.
D <sub>IN</sub> <sup>1</sup>	Serial Data Input. Data must be valid upon the falling edge of SCLK.
TEST	Allows the same data to be simultaneously loaded to all channels of the AD5535. This pin is used for calibration purposes when loading zero scale and full scale to all channels. To invoke this feature, bring the TEST pin high. In normal operation, TEST should be tied low.
$\overline{\text{RESET}}$ <sup>1</sup>	Active Low Input. This pin can also be used to reset the complete device to its power-on reset conditions. Zero code is loaded to the DACs.
NC	No connect pins. The user should not connect any signals to these pins.

<sup>1</sup> Internal pull-up device on logic input; therefore, it can be left floating and defaults to a logic high condition.

# TYPICAL PERFORMANCE CHARACTERISTICS

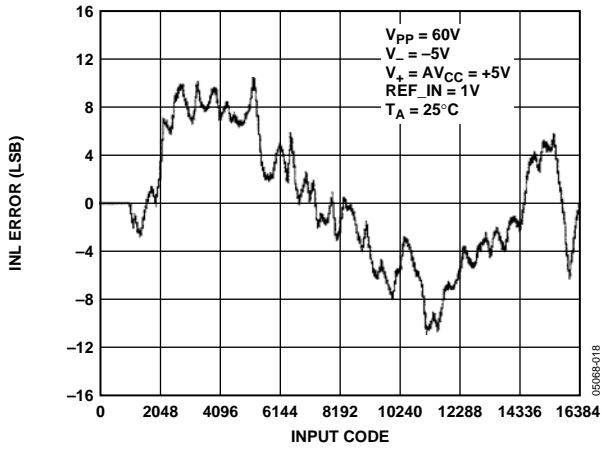

Figure 4. Integral Linearity with Full-Scale Range = 50 V

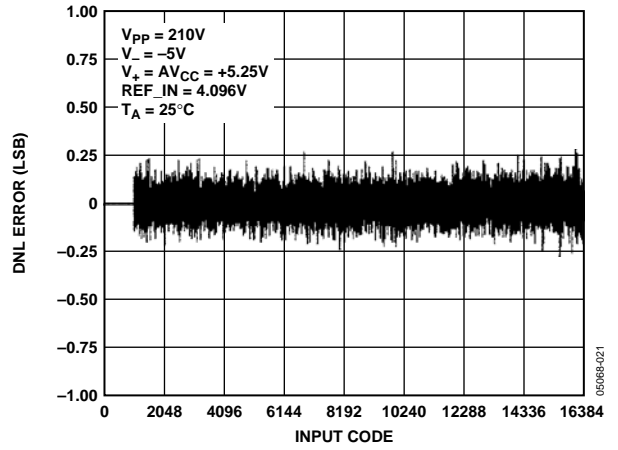

Figure 7. Differential Nonlinearity with Full-Scale Range = 200 V

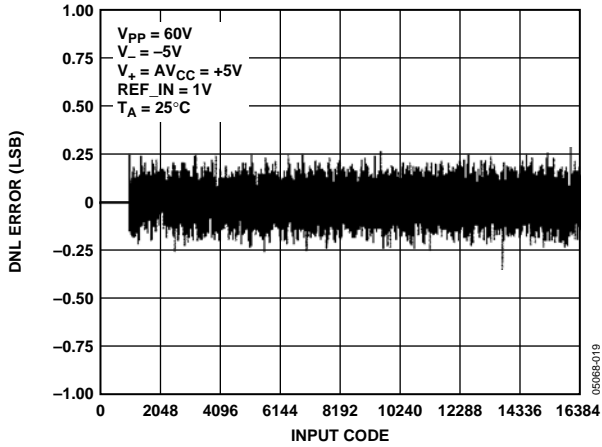

Figure 5. Differential Nonlinearity with Full-Scale Range = 50 V

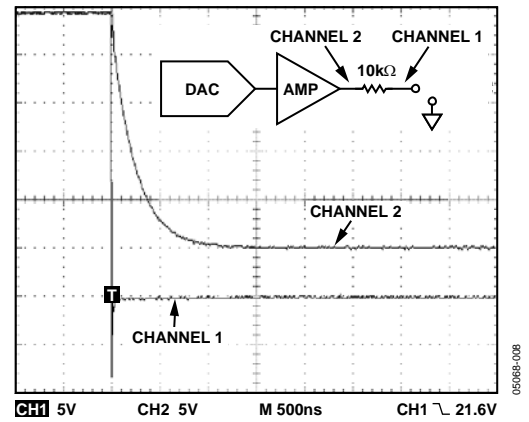

Figure 8. Short-Circuit Current Limit Timing

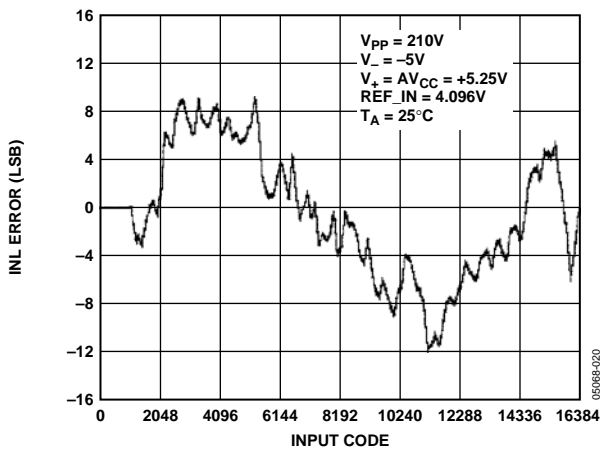

Figure 6. Integral Linearity with Full-Scale Range = 200 V

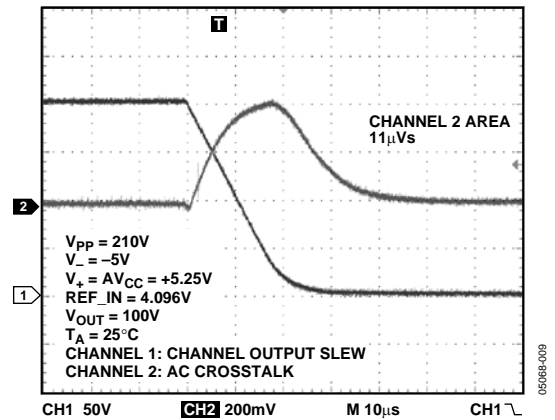

Figure 9. Worst-Case Adjacent Channel Crosstalk

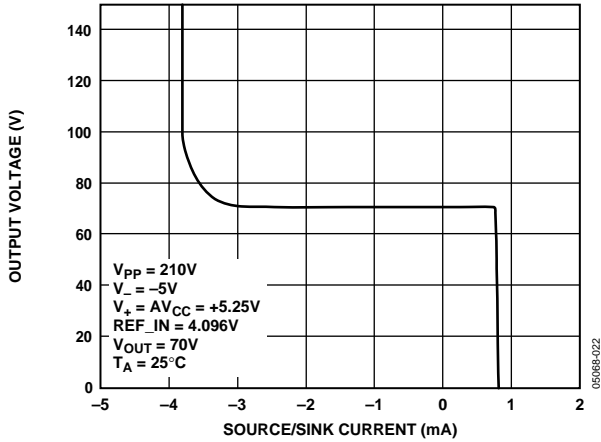

Figure 10. Output Amplifier Source and Sink Capability

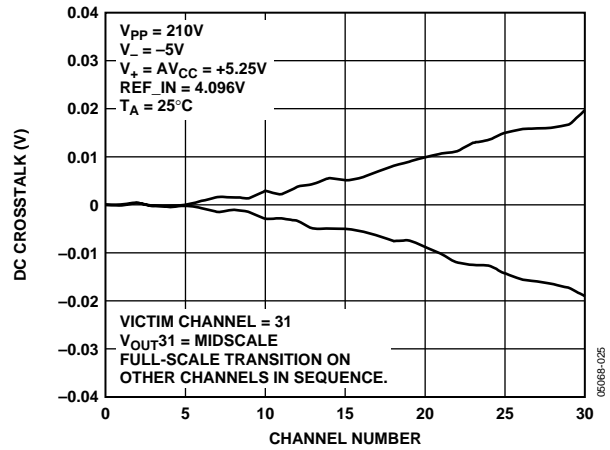

Figure 13. Cumulative DC Crosstalk Effects on a Single-Channel Output, Switching All Other Channels in Sequence

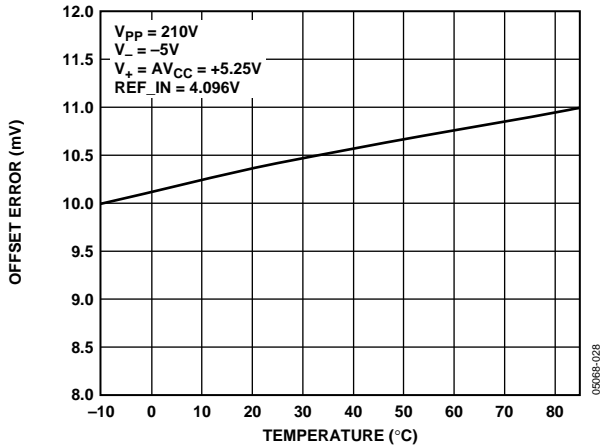

Figure 11. Offset Error vs. Temperature

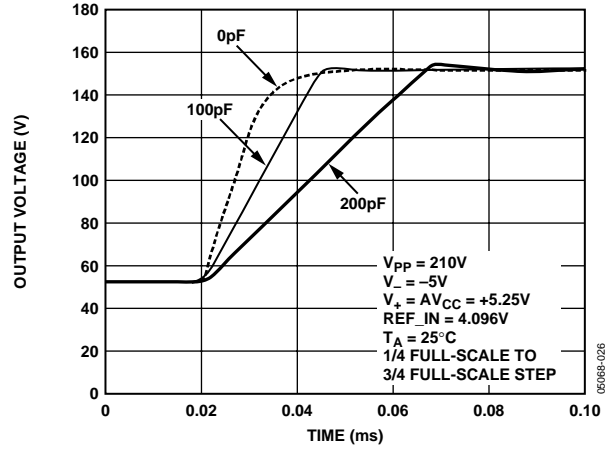

Figure 14. Settling Time vs. Capacitive Load

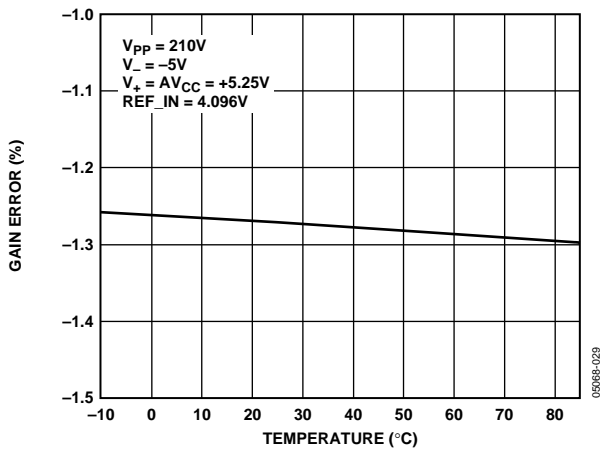

Figure 12. Gain Error vs. Temperature

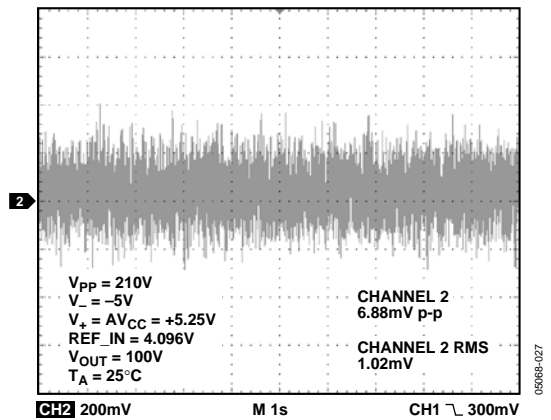

Figure 15. Wideband Noise

## TERMINOLOGY

### Integral Nonlinearity (INL)

A measure of the maximum deviation from a straight line passing through the endpoints of the DAC transfer function. It is expressed as a percentage of full-scale range.

### Differential Nonlinearity (DNL)

The difference between the measured change and the ideal 1 LSB change between any two adjacent codes. A specified DNL of  $\pm 1$  LSB maximum ensures monotonicity.

### Zero-Code Voltage

A measure of the output voltage present at the device output with all 0s loaded to the DAC. It includes the offset of the DAC and the output amplifier and is expressed in V.

### Offset Error

Calculated by taking two points in the linear region of the transfer function, drawing a line through these points, and extrapolating back to the y-axis. It is expressed in V.

### Voltage Gain

Calculated from the change in output voltage for a change in code, multiplied by 16,384, and divided by the REF\_IN voltage. This is calculated between two points in the linear section of the transfer function.

### Gain Error

A measure of the output error with all 1s loaded to the DAC, and the difference between the ideal and actual analog output range. Ideally, the output should be  $50 \times \text{REF\_IN}$ . It is expressed as a percentage of full-scale range.

### DC Power Supply Rejection Ratio (PSRR)

A measure of the change in analog output for a change in  $V_{PP}$  supply voltage. It is expressed in dB, and  $V_{PP}$  is varied  $\pm 5\%$ .

### DC Crosstalk

The dc change in the output level of one DAC at midscale in response to a full-scale code change (all 0s to all 1s and vice versa) and the output change of all other DACs. It is expressed in LSB.

### Output Voltage Settling Time

The time taken from when the last data bit is clocked into the DAC until the output has settled to within  $\pm 0.5$  LSB of its final value. Measured for a step change of  $\frac{1}{4}$  to  $\frac{3}{4}$  full scale.

### Digital-to-Analog Glitch Impulse

The area of the glitch injected into the analog output when the code in the DAC register changes state. It is specified as the area of the glitch in nV-s when the digital code is changed by 1 LSB at the major carry transition (011 . . . 11 to 100 . . . 00 or 100 . . . 00 to 011 . . . 11).

### Analog Crosstalk

The area of the glitch transferred to the output ( $V_{OUT}$ ) of one DAC due to a full-scale change in the output ( $V_{OUT}$ ) of another DAC. The area of the glitch is expressed in nV-s.

### Digital Feedthrough

A measure of the impulse injected into the analog outputs from the digital control inputs when the part is not being written to ( $\overline{\text{SYNC}}$  is high). It is specified in nV-s and measured with a worst-case change on the digital input pins, for example, from all 0s to all 1s and vice versa.

### Output Noise Spectral Density

A measure of internally generated random noise. Random noise is characterized as a spectral density (voltage per  $\sqrt{\text{Hz}}$ ). It is measured by loading all DACs to midscale and measuring noise at the output. It is measured in  $\text{nV}/\sqrt{\text{Hz}}$ .

## FUNCTIONAL DESCRIPTION

The AD5535 consists of a 32 channel, 14-bit DAC with 200 V high voltage amplifiers in a single 15 mm × 15 mm CSP\_BGA package. The output voltage range is programmable via the REF\_IN pin. The output range is 0 V to 50 V when REF\_IN = 1 V, and 0 V to 200 V when REF\_IN = 4 V. Communication to the device is through a serial interface operating at clock rates of up to 30 MHz, which is compatible with DSP and microcontroller interface standards. A 5-bit address and a 14-bit data-word are loaded into the AD5535 input register via the serial interface. The channel address is decoded, and the data-word is converted into an analog output voltage for this channel.

At power-on, all the DAC registers are loaded with 0s.

### DAC SECTION

The architecture of each DAC channel consists of a resistor string DAC, followed by an output buffer amplifier operating with a nominal gain of 50. The voltage at the REF\_IN pin provides the reference voltage for the corresponding DAC. The input coding to the DAC is straight binary, and the ideal DAC output voltage is given by

$$V_{OUT} = \frac{50 \times V_{REF\_IN} \times D}{2^{14}}$$

where  $D$  is the decimal equivalent (0 to 16,383) of the binary code, which is loaded to the DAC register.

The output buffer amplifier is specified to drive a load of 1 MΩ and 200 pF. The linear output voltage range for the output amplifier is from 7 V to  $V_{PP} - 10$  V. The amplifier output bandwidth is typically 5 kHz, and is capable of sourcing 700 μA and sinking 2.8 mA. Settling time for a ¼ to ¾ full-scale step change is typically 30 μs with no load and 65 μs with a 200 pF load.

### RESET FUNCTION

The reset function on the AD5535 can be used to reset all nodes on the device to their power-on reset condition. All the DACs are loaded with 0s, and all registers are cleared. The reset function is implemented by taking the  $\overline{\text{RESET}}$  pin low.

### SERIAL INTERFACE

The serial interface is controlled by three pins:

- $\overline{\text{SYNC}}$  is the frame synchronization pin for the serial interface.
- SCLK is the serial clock input. This pin operates at clock speeds of up to 30 MHz.
- $D_{IN}$  is the serial data input. Data must be valid upon the falling edge of SCLK.

To update a single DAC channel, a 19-bit data-word is written to the AD5535 input register.

### A4 to A0 Bits

These bits can address any one of the 32 channels. A4 is the MSB of the address; A0 is the LSB.

### DB13 to DB0 Bits

These bits are used to write a 14-bit word into the addressed DAC register.

Figure 2 is the timing diagram for a serial write to the AD5535. The serial interface works with both a continuous and a discontinuous serial clock. The first falling edge of  $\overline{\text{SYNC}}$  resets the serial clock counter to ensure that the correct number of bits are shifted into the serial shift register. Any further edges on  $\overline{\text{SYNC}}$  are ignored until the correct number of bits are shifted in. Once 19 bits have been shifted in, the SCLK is ignored. For another serial transfer to take place, the counter must be reset by the falling edge of  $\overline{\text{SYNC}}$ . The user must allow 200 ns (minimum) between successive writes.

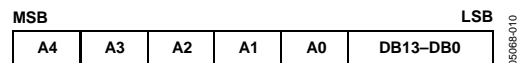

Figure 16. Serial Data Format

## MICROPROCESSOR INTERFACING

### AD5535-to-ADSP-21xx Interface

The ADSP-21xx family of DSPs is easily interfaced to the AD5535 without the need for extra logic. A data transfer is initiated by writing a word to the TX register after SPORT is enabled. In a write sequence, data is clocked out upon each rising edge of the DSP's serial clock and clocked into the AD5535 upon the falling edge of its SCLK. The easiest way to provide the 19-bit data-word required by the AD5535 is to transmit two 10-bit data-words from the ADSP-21xx. Ensure that the data is positioned correctly in the TX register so that the first 19 bits transmitted contain valid data.

Set up the SPORT control register as shown in Table 6.

Table 6.

Name	Value	Description
TFSW	1	Alternate framing
INVTFS	1	Active low frame signal
DTYPE	00	Right justify data
ISCLK	1	Internal serial clock
TFSR	1	Frame every word
ITFS	1	Internal framing signal
SLEN	1001	10-bit data-word

Figure 17 shows the connection diagram.

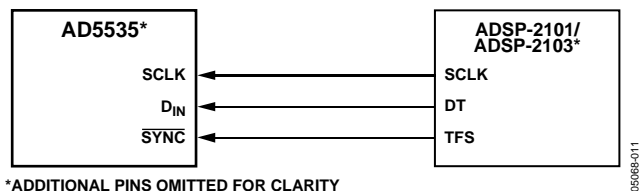

Figure 17. AD5535-to-ADSP-2101/ADSP-2103 Interface

### AD5535-to-MC68HC11 Interface

The serial peripheral interface (SPI) on the MC68HC11 is configured for master mode (MSTR = 1), clock polarity bit (CPOL) = 0, and clock phase bit (CPHA) = 1. The SPI is configured by writing to the SPI control register (SPCR)—see the *68HC11 User Manual*. SCK of the MC68HC11 drives the SCLK of the AD5535 and the MOSI output drives the serial data line (D<sub>IN</sub>) of the AD5535. The SYNC signal is derived from a port line (PC7). When data is being transmitted to the AD5535, the SYNC line is taken low (PC7).

Data appearing on the MOSI output is valid on the falling edge of SCK. The MC68HC11 transfers only eight bits of data during each serial transfer operation; therefore, three consecutive write operations are necessary to transmit 19 bits of data. Data is transmitted MSB first. It is important to left justify the data in the SPDR register so that the first 19 bits transmitted contain valid data. PC7 must be pulled low to start a transfer. It is taken high and pulled low again before any further write cycles can take place. See Figure 18.

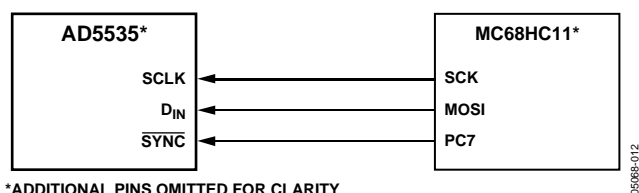

Figure 18. AD5535-to-MC68HC11 Interface

### AD5535-to-PIC16C6x/7x Interface

The PIC16C6x/7x synchronous serial port (SSP) is configured as an SPI master with the clock polarity bit = 0. This is done by writing to the synchronous serial port control register (SSPCON). See the *PIC16/17 Microcontroller User Manual*. In this example, I/O port RA1 is being used to pulse SYNC and enable the serial port of the AD5535. This microcontroller transfers only eight bits of data during each serial transfer operation; therefore, three consecutive write operations are necessary to transmit 19 bits of data. Data is transmitted MSB first. It is important to left justify the data in the SPDR register so that the first 19 bits transmitted contain valid data. RA1 must be pulled low to start a transfer. It must be brought high and pulled low again before any further write cycles can take place. Figure 19 shows the connection diagram.

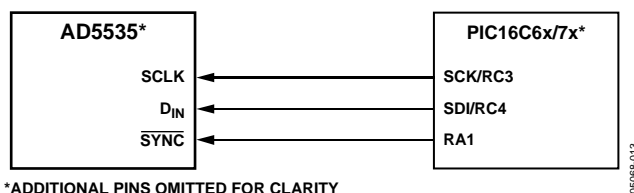

Figure 19. AD5535-to-PIC16C6x/7x Interface

### AD5535-to-8051 Interface

The AD5535 requires a clock synchronized to the serial data. The 8051 serial interface must therefore be operated in Mode 0. In this mode, serial data exits the 8051 through RxD, and a shift clock is output upon TxD. The SYNC signal is derived from a port line (P1.1). Figure 20 shows how the 8051 is connected to the AD5535. Because the AD5535 shifts data out upon the rising edge of the shift clock and latches data in upon the falling edge, the shift clock must be inverted. Note also that the AD5535 requires its data with the MSB first. Because the 8051 outputs the LSB first, the transmit routine must take this into account.

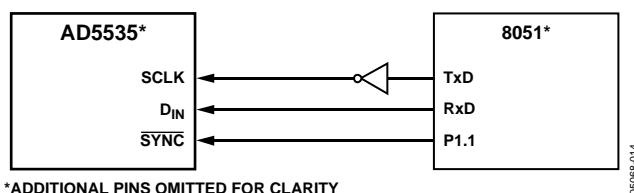

Figure 20. AD5535-to-8051 Interface

## APPLICATIONS

### MEMS MIRROR CONTROL APPLICATION

The AD5535 is targeted to all optical switching control systems based on MEMS technology. The AD5535 is a 32-channel, 14-bit DAC with integrated high voltage amplifiers. The output amplifiers are capable of generating an output range of 0 V to 200 V when using a 4 V reference. The full-scale output voltage is programmable from 50 V to 200 V using reference voltages from 1 V to 4 V. Each amplifier can output 700  $\mu$ A and directly drives the control actuators, which determine the position of MEMS mirrors in optical switch applications.

The AD5535 is generally used in a closed-loop feedback system, as shown in Figure 21, with a high resolution ADC and DSP. The exact position of each mirror is measured using capacitive sensors. The sensor outputs are multiplexed using an ADG739 4:1 multiplexer to an 8-channel, 14-bit ADC (AD7856). An alternative solution is to multiplex using a 32-to-1 multiplexer (ADG732) into a single-channel ADC (AD7671). The control loop is driven by an ADSP-21065L, a 32-bit SHARC<sup>®</sup> DSP with an SPI-compatible SPORT interface. With 14-bit monotonic behavior and 0 V to 200 V output range, coupled with its fast serial interface, the AD5535 is ideally suited for controlling a cluster of MEMS-based mirrors.

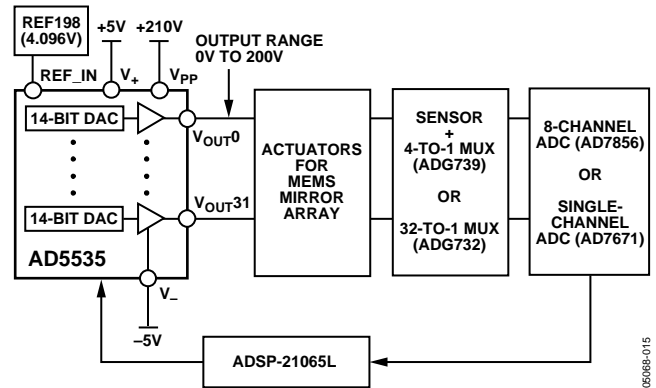

Figure 21. AD5535 in a MEMS-Based Optical Switch

### IPC-221-COMPLIANT BOARD LAYOUT

The diagram in Figure 22 is a typical 2-layer printed circuit board layout for the AD5535 that complies with the specifications outlined in IPC-221. No signals should be connected to the four corner balls labeled as original no connects. Balls labeled as additional no connects should be connected to AGND.

The routing shown in Figure 22 shows the feasibility of connecting to the high voltage balls while complying with the spacing requirements of IPC-221. Figure 22 also shows the physical distances that are available.

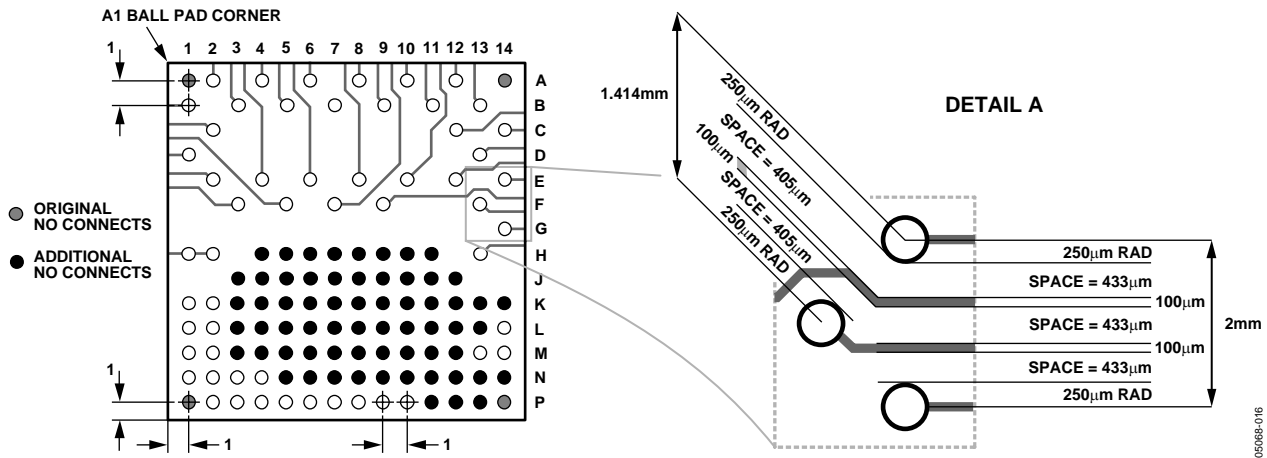

Figure 22. Layout Guidelines to Comply with IPC-221

## POWER SUPPLY SEQUENCING AND DECOUPLING RECOMMENDATIONS

The diagram in Figure 23 shows the recommended decoupling and power supply protection for the AD5535. On the AD5535, it is recommended to tie all grounds together as close to the device as possible. If the number of supplies must be reduced, all supplies should be brought back separately and a provision should be made on the board via a link option to drive the  $AV_{CC}$  and  $V_+$  from the same supply. All power supplies should be adequately decoupled with 10  $\mu\text{F}$  tantalum and 0.1  $\mu\text{F}$  ceramic capacitors. Note that the capacitors on the  $V_{PP}$  supply must be rated at greater than 210 V. To overcome issues associated with power supply sequencing when using high voltage supplies, the use of protection diodes as indicated in Figure 23 is recommended.

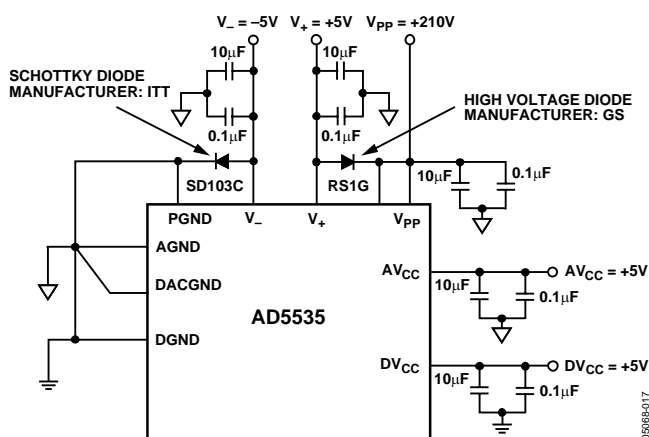

Figure 23. Recommended Power Supply Sequencing and Decoupling

## GUIDELINES FOR PRINTED CIRCUIT BOARD LAYOUT

Printed circuit boards should be designed such that the analog and digital sections are separated and confined to designated analog and digital sections of the board. This facilitates the use of ground planes that can be separated easily. A minimum etch technique is generally found to be the best for ground planes because it optimizes shielding of sensitive signal lines. Digital and analog ground planes should be joined only in one place, at the AGND and DGND pins of the high resolution converter. Data and address buses on the board should be buffered or latched to isolate the high frequency bus of the processor from the bus of the high resolution converters. These act as a faraday shield and increase the signal-to-noise performance of the converters by reducing the amount of high frequency digital coupling. Avoid running digital lines under the device because they couple noise onto the die. The ground plane should be allowed to run under the IC to avoid noise coupling.

Use as large a trace as possible for the supply lines of the device to provide low impedance paths and reduce the effects of glitches on the power supply line. Components, such as clocks with fast-switching signals, should be shielded with digital ground to avoid radiating noise to other sections of the board. Clock signals should never be run near the analog inputs of the device. Avoid crossovers of digital and analog signals. Traces for analog inputs should be kept as wide and short as possible and should be shielded with analog ground if possible. Traces on opposite sides of a 2-layer printed circuit board should run at right angles to each other to reduce the effects of feedthrough through the board.

A microstrip technique is by far the best, but it is not always possible to use with a double-sided board. In this technique, the component side of the board is dedicated to ground planes, and signals are placed on the solder side. Multilayer printed circuit boards with dedicated ground, power, and tracking layers offer the optimum solution in terms of obtaining analog performance, but at increased manufacturing costs.

Good decoupling is vitally important when using high resolution converters. All analog supplies should be decoupled with 10  $\mu\text{F}$  tantalum in parallel with 0.1  $\mu\text{F}$  ceramic capacitors to analog ground. To achieve the best from the decoupling components, these should be placed as close to the device as possible, ideally right up against the IC or the IC socket. The main aim of a bypassing element is to maximize the charge stored in the bypass loop while simultaneously minimizing the inductance of this loop. Inductance in the loop acts as an impedance to high frequency transients and results in power supply spiking. By keeping the decoupling as close to the device as possible, the loop area is kept as small as possible, thereby reducing the possibility of power supply spikes. Digital supplies of high resolution converters should be decoupled with 10  $\mu\text{F}$  tantalum and 0.1  $\mu\text{F}$  ceramic to the digital ground plane. The amplifiers'  $V_{DD}$  and  $V_{SS}$  supplies should be decoupled with 10  $\mu\text{F}$  and 0.1  $\mu\text{F}$  to AGND.

All logic chips should be decoupled with 0.1  $\mu\text{F}$  to digital ground to decouple high frequency effects associated with digital circuitry.

## OUTLINE DIMENSIONS

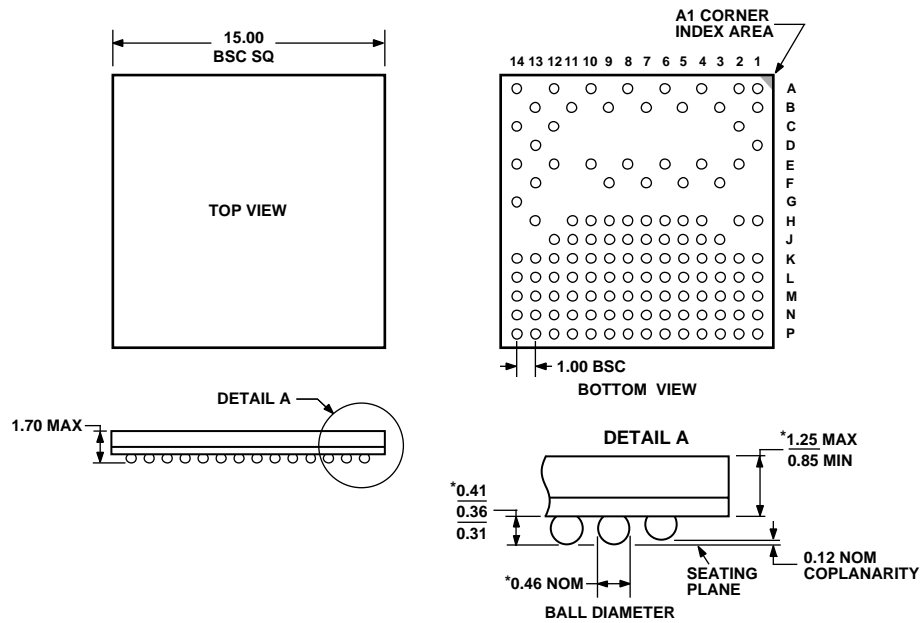

\*COMPLIANT WITH JEDEC STANDARDS MO-192-AAE-1  
WITH EXCEPTION TO DIMENSIONS INDICATED BY AN ASTERISK.  
NOMINAL BALL SIZE IS REDUCED FROM 0.60mm TO 0.46mm.  
Figure 24. 124-Lead Chip Scale Package Ball Grid Array [CSP\_BGA]  
(BC-124-2)  
Dimensions shown in millimeters

## ORDERING GUIDE

Model	Function	Output Voltage Span	Temperature Range	Package Description	Package Option
AD5535ABC	32 DACs	0 V to 200 V maximum	-10°C to +85°C	124-Lead CSP_BGA	BC-124-2
AD5535ABCZ <sup>1</sup>	32 DACs	0 V to 200 V maximum	-10°C to +85°C	124-Lead CSP_BGA	BC-124-2
EVAL-AD5535EB				Evaluation Board	

<sup>1</sup> Z = Pb-free part.

## Looking for pricing, stock, or lifecycle information?

Click below to explore more details on WIN SOURCE:

 [View AD5535ABCZ on WIN SOURCE](#)

 [Analog Devices Inc. Information](#)

## Optimize Your Supply Chain with WIN SOURCE Solutions

-  Global Sourcing Solution
-  Obsolete Management
-  Cost Control Management
-  Shortage Management
-  Alternative Solution
-  Excess Inventory Management