



**THE DATASHEET OF  
AT49F8192AT-70TC**



## Features

- Single Voltage Operation
  - 5V Read
  - 5V Programming
- Fast Read Access Time - 70 ns
- Internal Erase/Program Control
- Sector Architecture
  - One 8K Words (16K bytes) Boot Block with Programming Lockout
  - Two 4K Words (8K bytes) Parameter Blocks
  - One 496K Words (992K bytes) Main Memory Array Block
- Fast Sector Erase Time - 10 seconds
- Byte-by-byte or Word-by-word Programming - 10  $\mu$ s Typical
- Hardware Data Protection
- DATA Polling For End Of Program Detection
- Low Power Dissipation
  - 50 mA Active Current
  - 300  $\mu$ A CMOS Standby Current
- Typical 10,000 Write Cycles

## Description

The AT49F008A(T) and AT49F8192A(T) are 5-volt, 8-megabit Flash memories organized as 1,048,576 words of 8 bits each or 512K words of 16 bits each. Manufactured with Atmel's advanced nonvolatile CMOS technology, the devices offer access times to 70 ns with power dissipation of just 275 mW. When deselected, the CMOS standby current is less than 300  $\mu$ A.

The device contains a user-enabled "boot block" protection feature. Two versions of the feature are available: the AT49F008A/8192A locates the boot block at lowest order addresses ("bottom boot"); the AT49F008AT/8192AT locates it at highest order addresses ("top boot").

To allow for simple in-system reprogrammability, the AT49F008A(T)/8192A(T) does not require high input voltages for programming. Reading data out of the device is similar to reading from an EPROM; it has standard  $\overline{CE}$ ,  $\overline{OE}$ , and  $\overline{WE}$  inputs to avoid bus contention. Reprogramming the AT49F008A(T)/8192A(T) is performed by first erasing a block of data and then programming on a byte-by-byte or word-by-word basis.

*(continued)*

## Pin Configurations

| Pin Name          | Function   |
|-------------------|--|
| A0 - A18          | Addresses  |
| $\overline{CE}$   | Chip Enable  |
| $\overline{OE}$   | Output Enable  |
| $\overline{WE}$   | Write Enable   |
| RESET             | Reset  |
| RDY/BUSY          | Ready/Busy Output  |
| I/O0 - I/O14      | Data Inputs/Outputs  |
| I/O15 (A-1)       | I/O15 (Data Input/Output, Word Mode)<br>A-1 (LSB Address Input, Byte Mode) |
| $\overline{BYTE}$ | Selects Byte or Word Mode  |
| NC                | No Connect   |



**8-megabit  
(1M x 8/  
512K x 16)  
Flash Memory**

**AT49F008A  
AT49F008AT  
AT49F8192A  
AT49F8192AT**

Rev. 1199D-08/99





AT49F8192A(T) TSOP Top View

Type 1

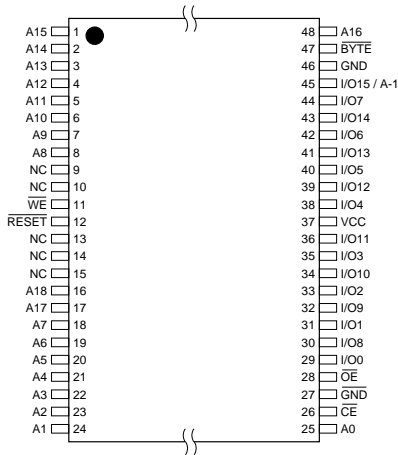

AT49F8192A(T) SOIC (SOP) Top View

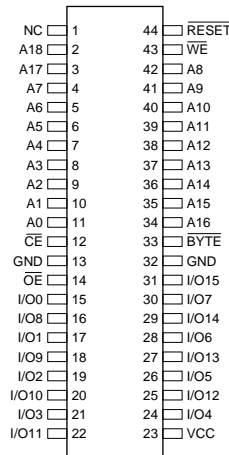

AT49F008A(T) TSOP Top View

Type 1

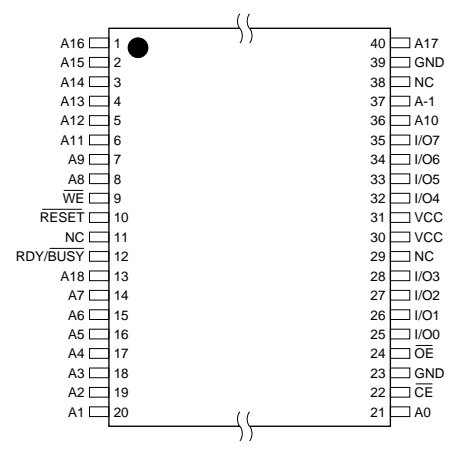

AT49F8192A(T)  
CBGA Top View (Ball Down)

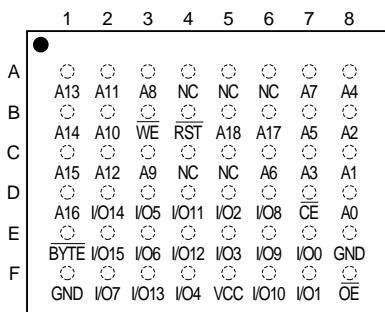

AT49F008A(T) Standard Pin Definition  
CBGA Top View (Ball Down)

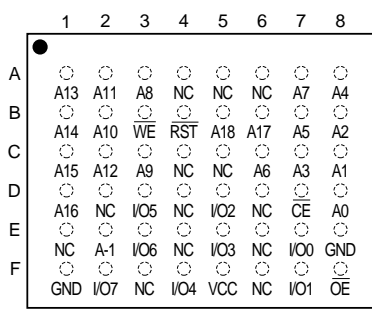

AT49F008A(T) Alternate Pin Definition  
CBGA Top View (Ball Down)

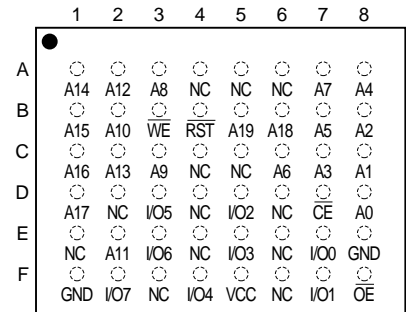

Note: "•" denotes a white dot marked on the package.

The device is erased by executing the erase command sequence; the device internally controls the erase operation. The memory is divided into four blocks for erase operations. There are two 4K word parameter block sections, the boot block, and the main memory array block. The typical number of program and erase cycles is in excess of 10,000 cycles.

The optional 8K word boot block section includes a reprogramming lock out feature to provide data integrity. This feature is enabled by a command sequence. Once the boot block programming lockout feature is enabled, the data in the boot block cannot be changed when input levels of 3.6

volts or less are used. The boot sector is designed to contain user secure code.

For the AT49F8192A(T), the  $\overline{\text{BYTE}}$  pin controls whether the device data I/O pins operate in the byte or word configuration. If the  $\overline{\text{BYTE}}$  pin is set at a logic "1" or left open, the device is in word configuration, I/O0 - I/O15 are active and controlled by  $\overline{\text{CE}}$  and  $\overline{\text{OE}}$ .

If the  $\overline{\text{BYTE}}$  pin is set at logic "0", the device is in byte configuration, and only data I/O pins I/O0 - I/O7 are active and controlled by  $\overline{\text{CE}}$  and  $\overline{\text{OE}}$ . The data I/O pins I/O8 - I/O14 are tri-stated and the I/O15 pin is used as an input for the LSB (A-1) address function.

## AT49F008A(T) Block Diagram

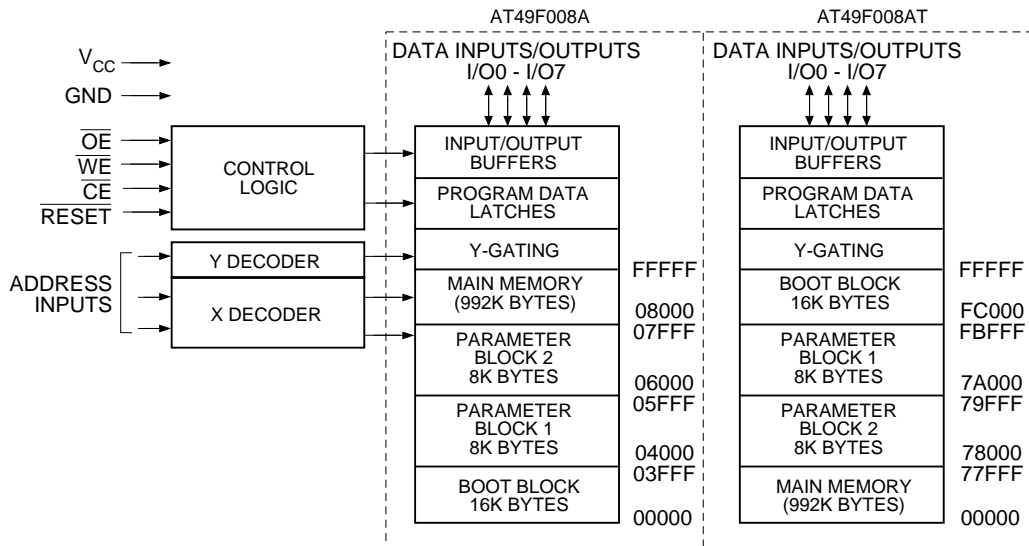

## AT49F8192A(T) Block Diagram

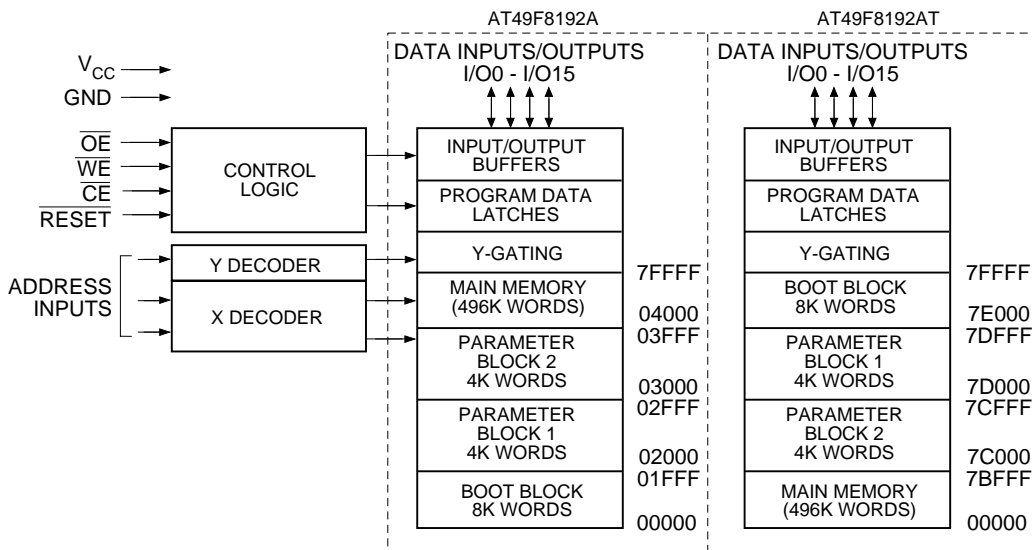

## Device Operation

**READ:** The AT49F008A(T)/8192A(T) is accessed like an EPROM. When  $\overline{CE}$  and  $\overline{OE}$  are low and  $\overline{WE}$  is high, the data stored at the memory location determined by the address pins is asserted on the outputs. The outputs are put in the high impedance state whenever  $\overline{CE}$  or  $\overline{OE}$  is high. This dual-line control gives designers flexibility in preventing bus contention.

**COMMAND SEQUENCES:** When the device is first powered on it will be reset to the read or standby mode depending upon the state of the control line inputs. In order to perform other device functions, a series of command sequences are entered into the device. The command

sequences are shown in the Command Definitions table (I/O8 - I/O15 are don't care inputs for the command codes). The command sequences are written by applying a low pulse on the  $\overline{WE}$  or  $\overline{CE}$  input with  $\overline{CE}$  or  $\overline{WE}$  low (respectively) and  $\overline{OE}$  high. The address is latched on the falling edge of  $\overline{CE}$  or  $\overline{WE}$ , whichever occurs last. The data is latched by the first rising edge of  $\overline{CE}$  or  $\overline{WE}$ . Standard microprocessor write timings are used. The address locations used in the command sequences are not affected by entering the command sequences.

**RESET:** A RESET input pin is provided to ease some system applications. When RESET is at a logic high level, the

device is in its standard operating mode. A low level on the  $\overline{\text{RESET}}$  input halts the present device operation and puts the outputs of the device in a high impedance state. When a high level is reasserted on the  $\overline{\text{RESET}}$  pin, the device returns to the Read or Standby mode, depending upon the state of the control inputs. By applying a  $12\text{V} \pm 0.5\text{V}$  input signal to the  $\overline{\text{RESET}}$  pin the boot block array can be reprogrammed even if the boot block program lockout feature has been enabled (see Boot Block Programming Lockout Override section).

**ERASURE:** Before a byte or word can be reprogrammed, it must be erased. The erased state of memory bits is a logical “1”. The entire device can be erased by using the Chip Erase command or individual sectors can be erased by using the Sector Erase commands.

**CHIP ERASE:** The entire device can be erased at one time by using the 6-byte chip erase software code. After the chip erase has been initiated, the device will internally time the erase operation so that no external clocks are required. The maximum time to erase the chip is  $t_{\text{EC}}$ .

If the boot block lockout has been enabled, the Chip Erase will not erase the data in the boot block; it will erase the main memory block and the parameter blocks only. After the chip erase, the device will return to the read or standby mode.

**SECTOR ERASE:** As an alternative to a full chip erase, the device is organized into four sectors that can be individually erased. There are two 4K word parameter block sections, one boot block, and the main memory array block. The Sector Erase command is a six bus cycle operation. The sector address is latched on the falling  $\overline{\text{WE}}$  edge of the sixth cycle while the 30H data input command is latched at the rising edge of  $\overline{\text{WE}}$ . The sector erase starts after the rising edge of  $\overline{\text{WE}}$  of the sixth cycle. The erase operation is internally controlled; it will automatically time to completion. Whenever the main memory block is erased and reprogrammed, the two parameter blocks should be erased and reprogrammed before the main memory block is erased again. Whenever a parameter block is erased and reprogrammed, the other parameter block should be erased and reprogrammed before the first parameter block is erased again. Whenever the boot block is erased and reprogrammed, the main memory block and the parameter blocks should be erased and reprogrammed before the boot block is erased again.

**BYTE/WORD PROGRAMMING:** Once a memory block is erased, it is programmed (to a logical “0”) on a byte-by-byte or word-by-word basis. Programming is accomplished via the internal device command register and is a 4 bus cycle operation. The device will automatically generate the required internal program pulses.

Any commands written to the chip during the embedded programming cycle will be ignored. If a hardware reset hap-

pens during programming, the data at the location being programmed will be corrupted. Please note that a data “0” cannot be programmed back to a “1”; only erase operations can convert “0”s to “1”s. Programming is completed after the specified  $t_{\text{BP}}$  cycle time. The  $\overline{\text{DATA}}$  polling feature may also be used to indicate the end of a program cycle.

**BOOT BLOCK PROGRAMMING LOCKOUT:** The device has one designated block that has a programming lockout feature. This feature prevents programming of data in the designated block once the feature has been enabled. The size of the block is 8K words. This block, referred to as the boot block, can contain secure code that is used to bring up the system. Enabling the lockout feature will allow the boot code to stay in the device while data in the rest of the device is updated. This feature does not have to be activated; the boot block’s usage as a write protected region is optional to the user. The address range of the boot block is 00000H to 03FFFH for the AT49F008A; FC000H to FFFFFH for the AT49F008AT; 00000H to 01FFFH for the AT49F8192A; and 7E000H to 7FFFFH for the AT49F8192AT.

Once the feature is enabled, the data in the boot block can no longer be erased or programmed when input levels of 5.5V or less are used. Data in the main memory block can still be changed through the regular programming method. To activate the lockout feature, a series of six program commands to specific addresses with specific data must be performed. Please refer to the Command Definitions table.

**BOOT BLOCK LOCKOUT DETECTION:** A software method is available to determine if programming of the boot block section is locked out. When the device is in the software product identification mode (see Software Product Identification Entry and Exit sections) a read from the following address location will show if programming the boot block is locked out—00002H for the AT49F008A and AT49F8192A; FC002H for the AT49F008AT; and 7E002H for the AT49F8192AT. If the data on I/O0 is low, the boot block can be programmed; if the data on I/O0 is high, the program lockout feature has been enabled and the block cannot be programmed. The software product identification exit code should be used to return to standard operation.

**BOOT BLOCK PROGRAMMING LOCKOUT OVERRIDE:** The user can override the boot block programming lockout by taking the  $\overline{\text{RESET}}$  pin to 12 volts during the entire chip erase, sector erase or word programming operation. When the  $\overline{\text{RESET}}$  pin is brought back to TTL levels the boot block programming lockout feature is again active.

**PRODUCT IDENTIFICATION:** The product identification mode identifies the device and manufacturer as Atmel. It may be accessed by hardware or software operation. The hardware operation mode can be used by an external programmer to identify the correct programming algorithm for the Atmel product.

For details, see Operating Modes (for hardware operation) or Software Product Identification. The manufacturer and device code is the same for both modes.

**DATA POLLING:** The AT49F008A(T)/8192A(T) features DATA polling to indicate the end of a program cycle. During a program cycle an attempted read of the last byte loaded will result in the complement of the loaded data on I/O7. Once the program cycle has been completed, true data is valid on all outputs and the next cycle may begin. During a chip or sector erase operation, an attempt to read the device will give a "0" on I/O7. Once the program or erase cycle has completed, true data will be read from the device. DATA polling may begin at any time during the program cycle.

**TOGGLE BIT:** In addition to DATA polling the AT49F008A(T)/8192A(T) provides another method for determining the end of a program or erase cycle. During a program or erase operation, successive attempts to read data from the device will result in I/O6 toggling between one and zero. Once the program cycle has completed, I/O6 will stop toggling and valid data will be read. Examining the toggle bit may begin at any time during a program cycle.

**READY/BUSY:** For the AT49F008A(T), pin 12 is an open drain READY/BUSY output pin which provides another

method of detecting the end of a program or erase operation. RDY/BUSY is actively pulled low during the internal program and erase cycles and it is released at the completion of the cycle. The open drain connection allows for OR-tying of several devices to the same RDY/BUSY line.

**HARDWARE DATA PROTECTION:** Hardware features protect against inadvertent programs to the AT49F008A(T)/8192A(T) in the following ways: (a)  $V_{CC}$  sense: if  $V_{CC}$  is below 3.8V (typical), the program function is inhibited. (b)  $V_{CC}$  power on delay: once  $V_{CC}$  has reached the  $V_{CC}$  sense level, the device will automatically time out 10 ms (typical) before programming. (c) Program inhibit: holding any one of OE low, CE high or WE high inhibits program cycles. (d) Noise filter: pulses of less than 15 ns (typical) on the WE or CE inputs will not initiate a program cycle.

**AT49F008A(T) ALTERNATE PIN DEFINITION:** Two AT49F008A(T) BGA pin definitions are shown. The standard pin definition allows use of the JEDEC standard programming algorithm. If the alternate pin definition is used, the programming algorithm must be modified as shown in the Command Definition for Alternate Pin Definition Table on page 7.



## Command Definition in Hex<sup>(1)</sup>

| Command Sequence                  | Bus Cycles | 1st Bus Cycle |                  | 2nd Bus Cycle |      | 3rd Bus Cycle |      | 4th Bus Cycle |                 | 5th Bus Cycle |      | 6th Bus Cycle     |      |
|-----------------------------------|------------|---------------|------------------|---------------|------|---------------|------|---------------|-----------------|---------------|------|-------------------|------|
|                                   |            | Addr          | Data             | Addr          | Data | Addr          | Data | Addr          | Data            | Addr          | Data | Addr              | Data |
| Read                              | 1          | Addr          | D <sub>OUT</sub> |               |      |               |      |               |                 |               |      |                   |      |
| Chip Erase                        | 6          | 5555          | AA               | 2AAA          | 55   | 5555          | 80   | 5555          | AA              | 2AAA          | 55   | 5555              | 10   |
| Sector Erase                      | 6          | 5555          | AA               | 2AAA          | 55   | 5555          | 80   | 5555          | AA              | 2AAA          | 55   | SA <sup>(4)</sup> | 30   |
| Byte/Word Program                 | 4          | 5555          | AA               | 2AAA          | 55   | 5555          | A0   | Addr          | D <sub>IN</sub> |               |      |                   |      |
| Boot Block Lockout <sup>(2)</sup> | 6          | 5555          | AA               | 2AAA          | 55   | 5555          | 80   | 5555          | AA              | 2AAA          | 55   | 5555              | 40   |
| Product ID Entry                  | 3          | 5555          | AA               | 2AAA          | 55   | 5555          | 90   |               |                 |               |      |                   |      |
| Product ID Exit <sup>(3)</sup>    | 3          | 5555          | AA               | 2AAA          | 55   | 5555          | F0   |               |                 |               |      |                   |      |
| Product ID Exit <sup>(3)</sup>    | 1          | xxxx          | F0               |               |      |               |      |               |                 |               |      |                   |      |

- Notes:
- The DATA FORMAT in each bus cycle is as follows: I/O15 - I/O8 (Don't Care); I/O7 - I/O0 (Hex)  
The ADDRESS FORMAT in each bus cycle is as follows: A15 - A0 (Hex), A-1, and A15 - A18 (Don't Care)
  - The boot sector has the address range 00000H to 03FFFH for the AT49F008A; FC000H to FFFFFH for the AT49F008AT; 00000H to 01FFFH for the AT49F8192A; and 7E000H to 7FFFFH for the AT49F8192AT.
  - Either one of the Product ID Exit commands can be used.
  - SA = sector addresses: (A0 - A18)  
For the AT49F008A/8192A  
SA = 01XXX for BOOT BLOCK  
SA = 02XXX for PARAMETER BLOCK 1  
SA = 03XXX for PARAMETER BLOCK 2  
SA = 7FXXX for MAIN MEMORY ARRAY  
  
For the AT49F008AT/8192AT  
SA = 7FXXX for BOOT BLOCK  
SA = 7DXXX for PARAMETER BLOCK 1  
SA = 7CXXX for PARAMETER BLOCK 2  
SA = 7BXXX for MAIN MEMORY ARRAY

## Absolute Maximum Ratings\*

|   |                                 |
|---|---------------------------------|
| Temperature Under Bias .....  | -55°C to +125°C                 |
| Storage Temperature .....   | -65°C to +150°C                 |
| All Input Voltages<br>(including NC Pins)<br>with Respect to Ground ..... | -0.6V to +6.25V                 |
| All Output Voltages<br>with Respect to Ground .....                       | -0.6V to V <sub>CC</sub> + 0.6V |
| Voltage on $\overline{\text{RESET}}$<br>with Respect to Ground .....      | -0.6V to +13.5V                 |

\*NOTICE: Stresses beyond those listed under "Absolute Maximum Ratings" may cause permanent damage to the device. This is a stress rating only and functional operation of the device at these or any other conditions beyond those indicated in the operational sections of this specification is not implied. Exposure to absolute maximum rating conditions for extended periods may affect device reliability.

## Command Definition (in Hex) for Alternate Pin Definition of AT49F008A(T)<sup>(1)</sup>

| Command Sequence                  | Bus Cycles | 1st Bus Cycle |                  | 2nd Bus Cycle |      | 3rd Bus Cycle |      | 4th Bus Cycle |                 | 5th Bus Cycle |      | 6th Bus Cycle     |      |
|-----------------------------------|------------|---------------|------------------|---------------|------|---------------|------|---------------|-----------------|---------------|------|-------------------|------|
|                                   |            | Addr          | Data             | Addr          | Data | Addr          | Data | Addr          | Data            | Addr          | Data | Addr              | Data |
| Read                              | 1          | Addr          | D <sub>OUT</sub> |               |      |               |      |               |                 |               |      |                   |      |
| Chip Erase                        | 6          | A555          | AA               | 5AAA          | 55   | A555          | 80   | A555          | AA              | 5AAA          | 55   | A555              | 10   |
| Sector Erase                      | 6          | A555          | AA               | 5AAA          | 55   | A555          | 80   | A555          | AA              | 5AAA          | 55   | SA <sup>(4)</sup> | 30   |
| Byte/Word Program                 | 4          | A555          | AA               | 5AAA          | 55   | A555          | A0   | Addr          | D <sub>IN</sub> |               |      |                   |      |
| Boot Block Lockout <sup>(2)</sup> | 6          | A555          | AA               | 5AAA          | 55   | A555          | 80   | A555          | AA              | 5AAA          | 55   | A555              | 40   |
| Product ID Entry                  | 3          | A555          | AA               | 5AAA          | 55   | A555          | 90   |               |                 |               |      |                   |      |
| Product ID Exit <sup>(3)</sup>    | 3          | A555          | AA               | 5AAA          | 55   | A555          | F0   |               |                 |               |      |                   |      |
| Product ID Exit <sup>(3)</sup>    | 1          | xxxx          | F0               |               |      |               |      |               |                 |               |      |                   |      |

- Notes:
- The DATA FORMAT in each bus cycle is as follows: I/O15 - I/O8 (Don't Care); I/O7 - I/O0 (Hex)  
The ADDRESS FORMAT in each bus cycle is as follows: A15 - A0 (Hex), A-1, and A15 - A18 (Don't Care)
  - The boot sector has the address range 00000H to 03FFFH for the AT49F008A; FC000H to FFFFFH for the AT49F008AT; 00000H to 01FFFH for the AT49F8192A; and 7E000H to 7FFFFH for the AT49F8192AT.
  - Either one of the Product ID Exit commands can be used.
  - SA = sector addresses: (A0 - A18)  
For the AT49F008A/8192A  
SA = 02XXX for BOOT BLOCK  
SA = 04XXX for PARAMETER BLOCK 1  
SA = 06XXX for PARAMETER BLOCK 2  
SA = FEXXX for MAIN MEMORY ARRAY  
  
For the AT49F008AT/8192AT  
SA = FEXXX for BOOT BLOCK  
SA = FAXXX for PARAMETER BLOCK 1  
SA = 78XXX for PARAMETER BLOCK 2  
SA = 76XXX for MAIN MEMORY ARRAY

## Absolute Maximum Ratings\*

|  |                                 |
|--|---------------------------------|
| Temperature Under Bias.....  | -55°C to +125°C                 |
| Storage Temperature.....   | -65°C to +150°C                 |
| All Input Voltages<br>(including NC Pins)<br>with Respect to Ground..... | -0.6V to +6.25V                 |
| All Output Voltages<br>with Respect to Ground.....                       | -0.6V to V <sub>CC</sub> + 0.6V |
| Voltage on $\overline{\text{RESET}}$<br>with Respect to Ground.....      | -0.6V to +13.5V                 |

\*NOTICE: Stresses beyond those listed under "Absolute Maximum Ratings" may cause permanent damage to the device. This is a stress rating only and functional operation of the device at these or any other conditions beyond those indicated in the operational sections of this specification is not implied. Exposure to absolute maximum rating conditions for extended periods may affect device reliability.



## DC and AC Operating Range

|                              |      | AT49F008A(T)/8192A(T)-70 | AT49F008A(T)/8192A(T)-90 | AT49F008A(T)/8192A(T)-120 |
|------------------------------|------|--------------------------|--------------------------|---------------------------|
| Operating Temperature (Case) | Com. | 0°C - 70°C               | 0°C - 70°C               | 0°C - 70°C                |
|                              | Ind. | -40°C - 85°C             | -40°C - 85°C             | -40°C - 85°C              |
| V <sub>CC</sub> Power Supply |      | 5V ± 10%                 | 5V ± 10%                 | 5V ± 10%                  |

## Operating Modes

| Mode                         | $\overline{CE}$ | $\overline{OE}$  | $\overline{WE}$ | $\overline{RESET}$ | Ai   | I/O                              |
|------------------------------|-----------------|------------------|-----------------|--------------------|--|----------------------------------|
| Read                         | V <sub>IL</sub> | V <sub>IL</sub>  | V <sub>IH</sub> | V <sub>IH</sub>    | Ai   | D <sub>OUT</sub>                 |
| Program/Erase <sup>(2)</sup> | V <sub>IL</sub> | V <sub>IH</sub>  | V <sub>IL</sub> | V <sub>IH</sub>    | Ai   | D <sub>IN</sub>                  |
| Standby/Program Inhibit      | V <sub>IH</sub> | X <sup>(1)</sup> | X               | V <sub>IH</sub>    | X  | High Z                           |
| Program Inhibit              | X               | X                | V <sub>IH</sub> | V <sub>IH</sub>    |  |                                  |
| Program Inhibit              | X               | V <sub>IL</sub>  | X               | V <sub>IH</sub>    |  |                                  |
| Output Disable               | X               | V <sub>IH</sub>  | X               | V <sub>IH</sub>    |  | High Z                           |
| Reset                        | X               | X                | X               | V <sub>IL</sub>    | X  | High Z                           |
| Product Identification       |                 |                  |                 |                    |  |                                  |
| Hardware                     | V <sub>IL</sub> | V <sub>IL</sub>  | V <sub>IH</sub> | V <sub>IH</sub>    | A1 - A18 = V <sub>IL</sub> , A9 = V <sub>IH</sub> , <sup>(3)</sup><br>A0 = V <sub>IL</sub> | Manufacturer Code <sup>(4)</sup> |
|                              |                 |                  |                 |                    | A1 - A18 = V <sub>IL</sub> , A9 = V <sub>IH</sub> , <sup>(3)</sup><br>A0 = V <sub>IH</sub> | Device Code <sup>(4)</sup>       |
| Software <sup>(5)</sup>      |                 |                  |                 | V <sub>IH</sub>    | A0 = V <sub>IL</sub> , A1 - A18 = V <sub>IL</sub>  | Manufacturer Code <sup>(4)</sup> |
|                              |                 |                  |                 |                    | A0 = V <sub>IH</sub> , A1 - A18 = V <sub>IL</sub>  | Device Code <sup>(4)</sup>       |

- Notes:
- X can be V<sub>IL</sub> or V<sub>IH</sub>.
  - Refer to AC Programming Waveforms.
  - V<sub>H</sub> = 12.0V ± 0.5V.
  - Manufacturer Code: 1FH  
Device Code: 22H (AT49F008A), A0H (AT49F8192A), 21H (AT49F008AT), A3H (AT49F8192AT).
  - See details under Software Product Identification Entry/Exit.

## DC Characteristics

| Symbol                         | Parameter                            | Condition  | Min | Max  | Units |
|--------------------------------|--------------------------------------|--|-----|------|-------|
| I <sub>LI</sub>                | Input Load Current                   | V <sub>IN</sub> = 0V to V <sub>CC</sub>            |     | 10   | μA    |
| I <sub>LO</sub>                | Output Leakage Current               | V <sub>I/O</sub> = 0V to V <sub>CC</sub>           |     | 10   | μA    |
| I <sub>SB1</sub>               | V <sub>CC</sub> Standby Current CMOS | $\overline{CE} = V_{CC} - 0.3V$ to V <sub>CC</sub> |     | 300  | μA    |
| I <sub>SB2</sub>               | V <sub>CC</sub> Standby Current TTL  | $\overline{CE} = 2.0V$ to V <sub>CC</sub>          |     | 3    | mA    |
| I <sub>CC</sub> <sup>(1)</sup> | V <sub>CC</sub> Active Current       | f = 5 MHz; I <sub>OUT</sub> = 0 mA                 |     | 50   | mA    |
| V <sub>IL</sub>                | Input Low Voltage                    |  |     | 0.8  | V     |
| V <sub>IH</sub>                | Input High Voltage                   |  | 2.0 |      | V     |
| V <sub>OL</sub>                | Output Low Voltage                   | I <sub>OL</sub> = 2.1 mA                           |     | 0.45 | V     |
| V <sub>OH</sub>                | Output High Voltage                  | I <sub>OH</sub> = -400 μA                          | 2.4 |      | V     |

- Note: 1. In the erase mode, I<sub>CC</sub> is 90 mA.

## AC Read Characteristics

| Symbol            | Parameter   | AT49F008A(T)/8192A(T)-70 |     | AT49F008A(T)/8192A(T)-90 |     | AT49F008A(T)/8192A(T)-120 |     | Units |
|-------------------|---|--------------------------|-----|--------------------------|-----|---------------------------|-----|-------|
|                   |   | Min                      | Max | Min                      | Max | Min                       | Max |       |
| $t_{ACC}$         | Address to Output Delay   |                          | 70  |                          | 90  |                           | 120 | ns    |
| $t_{CE}^{(1)}$    | $\overline{CE}$ to Output Delay   |                          | 70  |                          | 90  |                           | 120 | ns    |
| $t_{OE}^{(2)}$    | $\overline{OE}$ to Output Delay   | 0                        | 30  | 0                        | 40  | 0                         | 50  | ns    |
| $t_{DF}^{(3)(4)}$ | $\overline{CE}$ or $\overline{OE}$ to Output Float                                      | 0                        | 25  | 0                        | 25  | 0                         | 30  | ns    |
| $t_{OH}$          | Output Hold from $\overline{OE}$ , $\overline{CE}$ or Address, whichever occurred first | 0                        |     | 0                        |     | 0                         |     | ns    |
| $t_{RO}$          | $\overline{RESET}$ to Output Delay  |                          | 800 |                          | 800 |                           | 800 | ns    |

## AC Read Waveforms<sup>(1)(2)(3)(4)</sup>

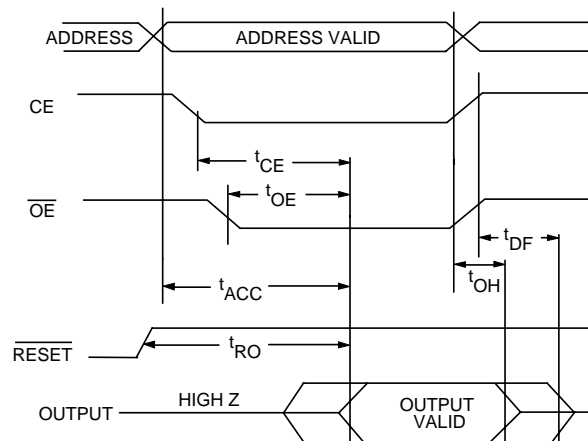

- Notes:
- $\overline{CE}$  may be delayed up to  $t_{ACC} - t_{CE}$  after the address transition without impact on  $t_{ACC}$ .
  - $\overline{OE}$  may be delayed up to  $t_{CE} - t_{OE}$  after the falling edge of  $\overline{CE}$  without impact on  $t_{CE}$  or by  $t_{ACC} - t_{OE}$  after an address change without impact on  $t_{ACC}$ .
  - $t_{DF}$  is specified from  $\overline{OE}$  or  $\overline{CE}$  whichever occurs first ( $C_L = 5$  pF).
  - This parameter is characterized and is not 100% tested.

## Input Test Waveforms and Measurement Level

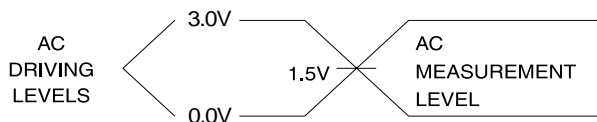

$t_R, t_F < 5$  ns

## Pin Capacitance

$f = 1$  MHz,  $T = 25^\circ\text{C}^{(1)}$

|           | Typ | Max | Units | Conditions     |
|-----------|-----|-----|-------|----------------|
| $C_{IN}$  | 4   | 6   | pF    | $V_{IN} = 0V$  |
| $C_{OUT}$ | 8   | 12  | pF    | $V_{OUT} = 0V$ |

Note: 1. This parameter is characterized and is not 100% tested.

## Output Test Load

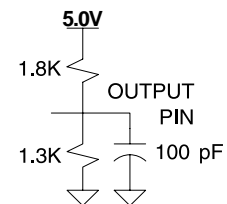

## AC Word Load Characteristics

| Symbol            | Parameter  | Min | Max | Units |
|-------------------|--|-----|-----|-------|
| $t_{AS}, t_{OES}$ | Address, $\overline{OE}$ Set-up Time                     | 10  |     | ns    |
| $t_{AH}$          | Address Hold Time  | 100 |     | ns    |
| $t_{CS}$          | Chip Select Set-up Time                                  | 0   |     | ns    |
| $t_{CH}$          | Chip Select Hold Time                                    | 0   |     | ns    |
| $t_{WP}$          | Write Pulse Width ( $\overline{WE}$ or $\overline{CE}$ ) | 100 |     | ns    |
| $t_{DS}$          | Data Set-up Time   | 100 |     | ns    |
| $t_{DH}, t_{OEH}$ | Data, $\overline{OE}$ Hold Time                          | 10  |     | ns    |
| $t_{WPH}$         | Write Pulse Width High                                   | 50  |     | ns    |

### AC Byte/Word Load Waveforms WE Controlled

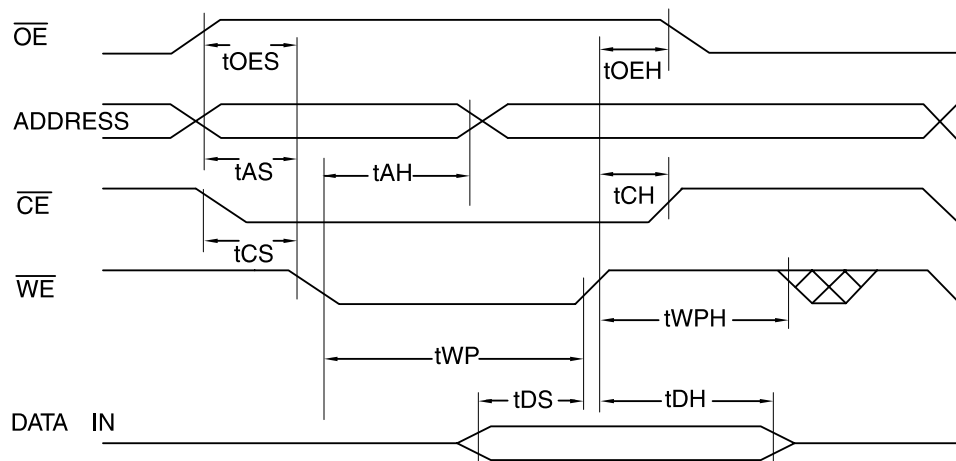

### $\overline{CE}$ Controlled

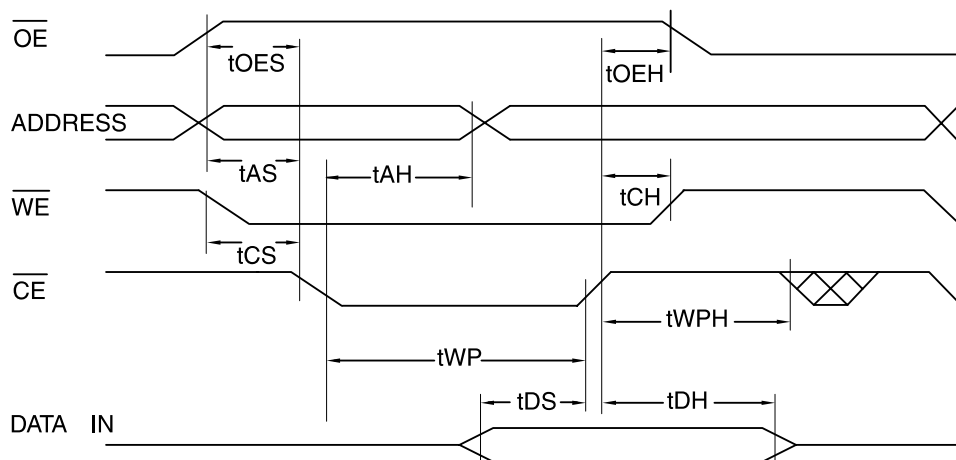

## Program Cycle Characteristics

| Symbol    | Parameter                  | Min | Typ | Max | Units   |
|-----------|----------------------------|-----|-----|-----|---------|
| $t_{BP}$  | Byte/Word Programming Time |     | 10  | 50  | $\mu$ s |
| $t_{AS}$  | Address Set-up Time        | 0   |     |     | ns      |
| $t_{AH}$  | Address Hold Time          | 100 |     |     | ns      |
| $t_{DS}$  | Data Set-up Time           | 100 |     |     | ns      |
| $t_{DH}$  | Data Hold Time             | 0   |     |     | ns      |
| $t_{WP}$  | Write Pulse Width          | 100 |     |     | ns      |
| $t_{WPH}$ | Write Pulse Width High     | 50  |     |     | ns      |
| $t_{EC}$  | Erase Cycle Time           |     |     | 10  | seconds |

## Program Cycle Waveforms

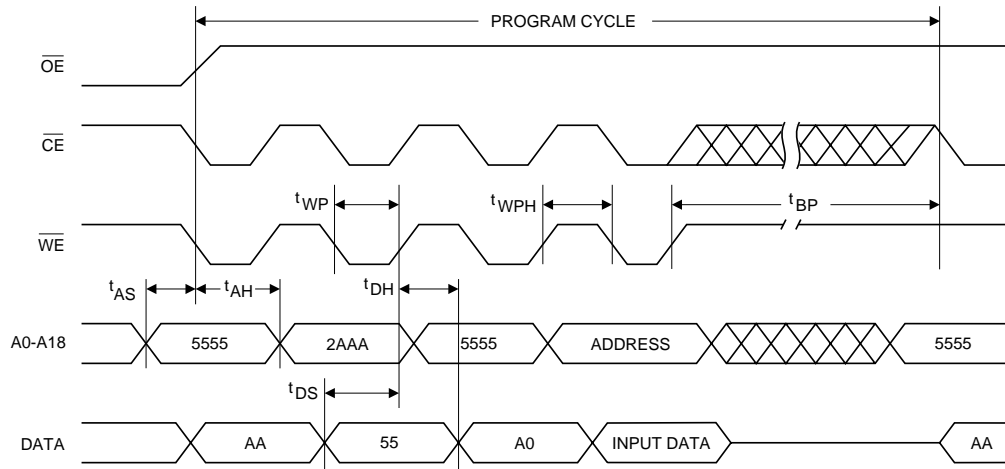

## Sector or Chip Erase Cycle Waveforms

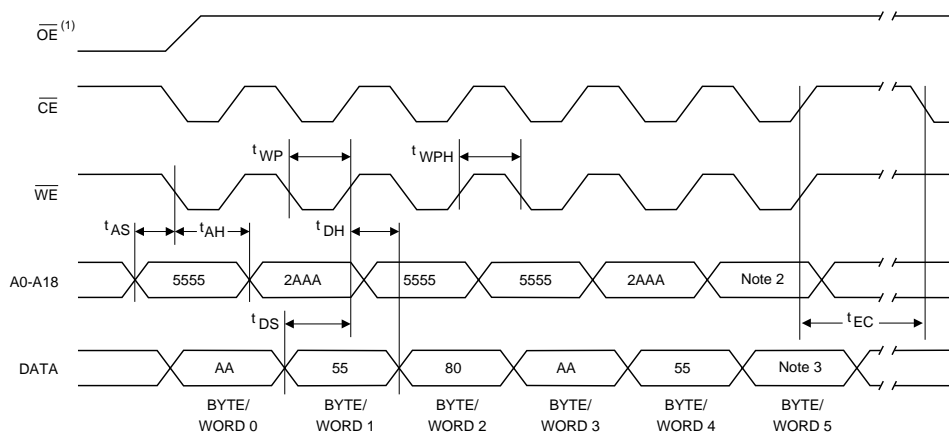

- Notes:
- $\overline{OE}$  must be high only when  $\overline{WE}$  and  $\overline{CE}$  are both low.
  - For chip erase, the address should be 5555. For sector erase, the address depends on what sector is to be erased. (See note 4 under command definitions.)
  - For chip erase, the data should be 10H, and for sector erase, the data should be 30H.

## Data Polling Characteristics<sup>(1)</sup>

| Symbol     | Parameter                                      | Min | Typ | Max | Units |
|------------|--|-----|-----|-----|-------|
| $t_{DH}$   | Data Hold Time                                 | 10  |     |     | ns    |
| $t_{OE H}$ | $\overline{OE}$ Hold Time                      | 10  |     |     | ns    |
| $t_{OE}$   | $\overline{OE}$ to Output Delay <sup>(2)</sup> |     |     |     | ns    |
| $t_{WR}$   | Write Recovery Time                            | 0   |     |     | ns    |

- Notes: 1. These parameters are characterized and not 100% tested.  
2. See  $t_{OE}$  spec in AC Read Characteristics.

## Data Polling Waveforms

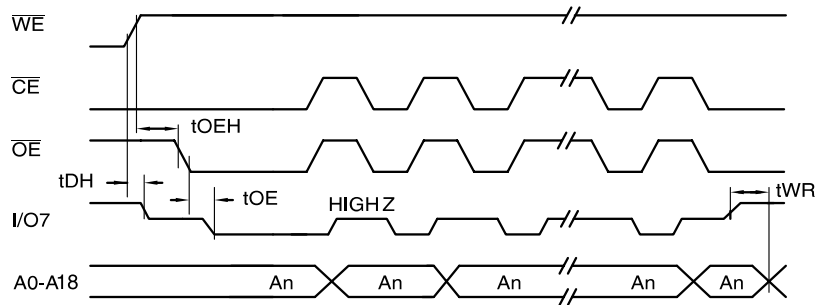

## Toggle Bit Characteristics<sup>(1)</sup>

| Symbol     | Parameter                                      | Min | Typ | Max | Units |
|------------|--|-----|-----|-----|-------|
| $t_{DH}$   | Data Hold Time                                 | 10  |     |     | ns    |
| $t_{OE H}$ | $\overline{OE}$ Hold Time                      | 10  |     |     | ns    |
| $t_{OE}$   | $\overline{OE}$ to Output Delay <sup>(2)</sup> |     |     |     | ns    |
| $t_{OEHP}$ | $\overline{OE}$ High Pulse                     | 150 |     |     | ns    |
| $t_{WR}$   | Write Recovery Time                            | 0   |     |     | ns    |

- Notes: 1. These parameters are characterized and not 100% tested.  
2. See  $t_{OE}$  spec in AC Read Characteristics.

## Toggle Bit Waveforms<sup>(1)(2)(3)</sup>

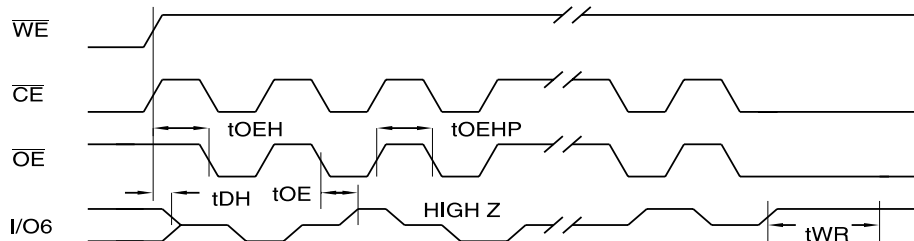

- Notes: 1. Toggling either  $\overline{OE}$  or  $\overline{CE}$  or both  $\overline{OE}$  and  $\overline{CE}$  will operate toggle bit. The  $t_{OEHP}$  specification must be met by the toggling input(s).  
2. Beginning and ending state of I/O6 will vary.  
3. Any address location may be used but the address should not vary.

## Software Product Identification Entry<sup>(1)</sup>

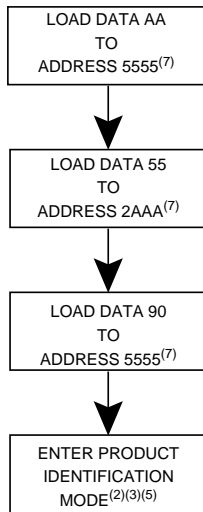

## Boot Block Lockout Enable Algorithm<sup>(1)</sup>

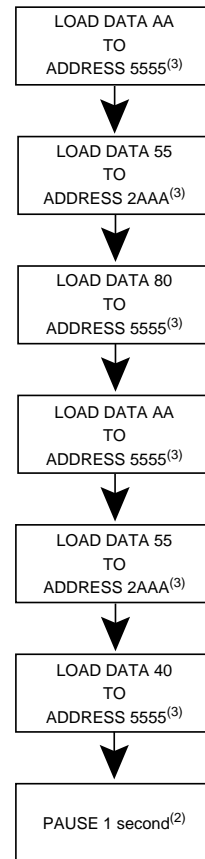

## Software Product Identification Exit<sup>(1)(6)</sup>

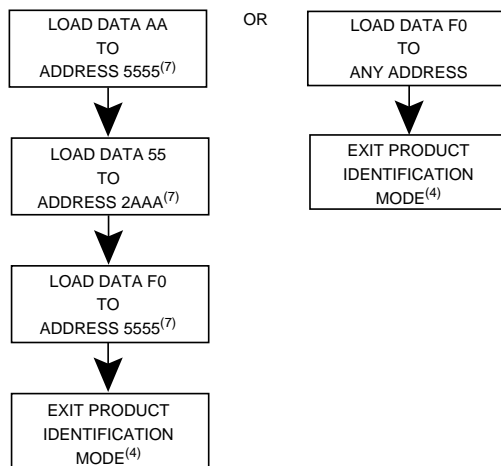

- Notes:
1. Data Format: I/O15 - I/O8 (Don't Care); I/O7 - I/O0 (Hex)  
Address Format: A15 - A0 (Hex), A-1, and A15 - A18 (Don't Care).
  2. Boot block lockout feature enabled.
  3. If the alternate pin definition is used, 5555 should be replaced with A555, 2AAA should be replaced with 5AAA.

- Notes:
1. Data Format: I/O15 - I/O8 (Don't Care); I/O7 - I/O0 (Hex)  
Address Format: A15 - A0 (Hex), A-1, and A15 - A18 (Don't Care).
  2. A1 - A18 = VIL.  
Manufacture Code is read for A0 = VIL;  
Device Code is read for A0 = VIH.
  3. The device does not remain in identification mode if powered down.
  4. The device returns to standard operation mode.
  5. Manufacturer Code: 1FH  
Device Code: 22H (AT49F008A), A0H (AT49F8192A), 21H (AT49F008AT), A3H (AT49F8192AT)
  6. Either one of the Product ID Exit commands can be used.
  7. If the alternate pin definition is used, 5555 should be replaced with A555, 2AAA should be replaced with 5AAA.



## AT49F008A(T) Ordering Information

| t <sub>ACC</sub><br>(ns) | I <sub>CC</sub> (mA) |         | Ordering Code   | Package | Operation Range              |
|--------------------------|----------------------|---------|-----------------|---------|------------------------------|
|                          | Active               | Standby |                 |         |                              |
| 70                       | 50                   | 0.3     | AT49F008A-70TC  | 40T     | Commercial<br>(0° to 70°C)   |
|                          |                      |         | AT49F008A-70CC  | 48C1    |                              |
|                          |                      |         | AT49F008A-70TI  | 40T     | Industrial<br>(-40° to 85°C) |
|                          |                      |         | AT49F008A-70CI  | 48C1    |                              |
| 90                       | 50                   | 0.3     | AT49F008A-90TC  | 40T     | Commercial<br>(0° to 70°C)   |
|                          |                      |         | AT49F008A-90CC  | 48C1    |                              |
|                          |                      |         | AT49F008A-90TI  | 40T     | Industrial<br>(-40° to 85°C) |
|                          |                      |         | AT49F008A-90CI  | 48C1    |                              |
| 120                      | 50                   | 0.3     | AT49F008A-12TC  | 40T     | Commercial<br>(0° to 70°C)   |
|                          |                      |         | AT49F008A-12CC  | 48C1    |                              |
|                          |                      |         | AT49F008A-12TI  | 40T     | Industrial<br>(-40° to 85°C) |
|                          |                      |         | AT49F008A-12CI  | 48C1    |                              |
| 70                       | 50                   | 0.3     | AT49F008AT-70TC | 40T     | Commercial<br>(0° to 70°C)   |
|                          |                      |         | AT49F008AT-70CC | 48C1    |                              |
|                          |                      |         | AT49F008AT-70TI | 40T     | Industrial<br>(-40° to 85°C) |
|                          |                      |         | AT49F008AT-70CI | 48C1    |                              |
| 90                       | 50                   | 0.3     | AT49F008AT-90TC | 40T     | Commercial<br>(0° to 70°C)   |
|                          |                      |         | AT49F008AT-90CC | 48C1    |                              |
|                          |                      |         | AT49F008AT-90TI | 40T     | Industrial<br>(-40° to 85°C) |
|                          |                      |         | AT49F008AT-90CI | 48C1    |                              |
| 120                      | 50                   | 0.3     | AT49F008AT-12TC | 40T     | Commercial<br>(0° to 70°C)   |
|                          |                      |         | AT49F008AT-12CC | 48C1    |                              |
|                          |                      |         | AT49F008AT-12TI | 40T     | Industrial<br>(-40° to 85°C) |
|                          |                      |         | AT49F008AT-12CI | 48C1    |                              |

| Package Type |  |
|--------------|--|
| <b>40T</b>   | 40-Lead, Plastic Thin Small Outline Package (TSOP) |
| <b>48C1</b>  | 48-Ball, Chip-Size Ball Grid Array Package (CBGA)  |

## AT49F8192A(T) Ordering Information

| t <sub>ACC</sub><br>(ns) | I <sub>CC</sub> (mA) |         | Ordering Code  | Package            | Operation Range              |
|--------------------------|----------------------|---------|--|--------------------|------------------------------|
|                          | Active               | Standby |  |                    |                              |
| 70                       | 50                   | 0.3     | AT49F8192A-70TC<br>AT49F8192A-70CC<br>AT49F8192A-70RC    | 48T<br>48C1<br>44R | Commercial<br>(0° to 70°C)   |
|                          |                      |         | AT49F8192A-70TI<br>AT49F8192A-70CI<br>AT49F8192A-70RI    | 48T<br>48C1<br>44R | Industrial<br>(-40° to 85°C) |
| 90                       | 50                   | 0.3     | AT49F8192A-90TC<br>AT49F8192A-90CC<br>AT49F8192A-90RC    | 48T<br>48C1<br>44R | Commercial<br>(0° to 70°C)   |
|                          |                      |         | AT49F8192A-90TI<br>AT49F8192A-90CI<br>AT49F8192A-90RI    | 48T<br>48C1<br>44R | Industrial<br>(-40° to 85°C) |
| 120                      | 50                   | 0.3     | AT49F8192A-12TC<br>AT49F8192A-12CC<br>AT49F8192A-12RC    | 48T<br>48C1<br>44R | Commercial<br>(0° to 70°C)   |
|                          |                      |         | AT49F8192A-12TI<br>AT49F8192A-12CI<br>AT49F8192A-12RI    | 48T<br>48C1<br>44R | Industrial<br>(-40° to 85°C) |
| 70                       | 50                   | 0.3     | AT49F8192AT-70TC<br>AT49F8192AT-70CC<br>AT49F8192AT-70RC | 48T<br>48C1<br>44R | Commercial<br>(0° to 70°C)   |
|                          |                      |         | AT49F8192AT-70TI<br>AT49F8192AT-70CI<br>AT49F8192AT-70RI | 48T<br>48C1<br>44R | Industrial<br>(-40° to 85°C) |
| 90                       | 50                   | 0.3     | AT49F8192AT-90TC<br>AT49F8192AT-90CC<br>AT49F8192AT-90RC | 48T<br>48C1<br>44R | Commercial<br>(0° to 70°C)   |
|                          |                      |         | AT49F8192AT-90TI<br>AT49F8192AT-90CI<br>AT49F8192AT-90RI | 48T<br>48C1<br>44R | Industrial<br>(-40° to 85°C) |
| 120                      | 50                   | 0.3     | AT49F8192AT-12TC<br>AT49F8192AT-12CC<br>AT49F8192AT-12RC | 48T<br>48C1<br>44R | Commercial<br>(0° to 70°C)   |
|                          |                      |         | AT49F8192AT-12TI<br>AT49F8192AT-12CI<br>AT49F8192AT-12RI | 48T<br>48C1<br>44R | Industrial<br>(-40° to 85°C) |

| Package Type |  |
|--------------|--|
| <b>48T</b>   | 48-Lead, Plastic Thin Small Outline Package (TSOP)                   |
| <b>48C1</b>  | 48-Ball, Chip-Size Ball Grid Array Package (CBGA)                    |
| <b>44R</b>   | 44-lead, 0.525" Wide, Plastic Gull Wing Small Outline Package (SOIC) |

## Packaging Information

**40T**, 40-Lead, Plastic Thin Small Outline Package (TSOP)  
 Dimensions in Inches and (Millimeters)\*

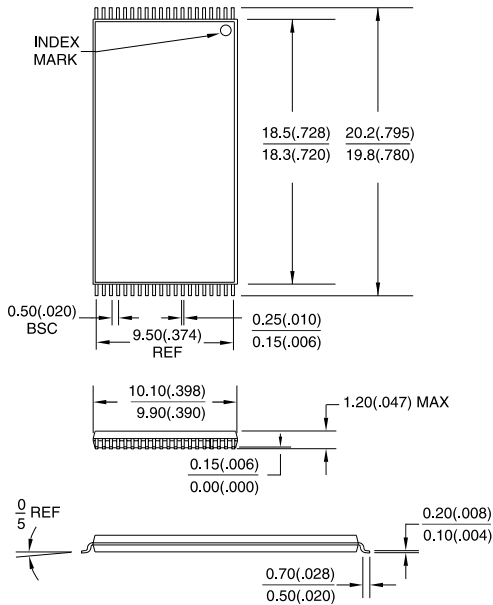

\*Controlling dimension: millimeters

**48T**, 48-Lead, Plastic Thin Small Outline Package (TSOP)  
 Dimensions in Millimeters and (Inches)\*  
 JEDEC OUTLINE MO-142 D

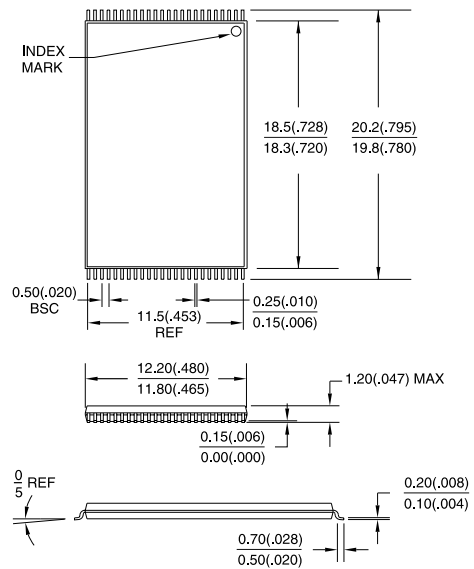

\*Controlling dimension: millimeters

**48C1**, 48-Ball, Chip-Size Ball Grid Array Package (CBGA)  
 Dimensions in Millimeters

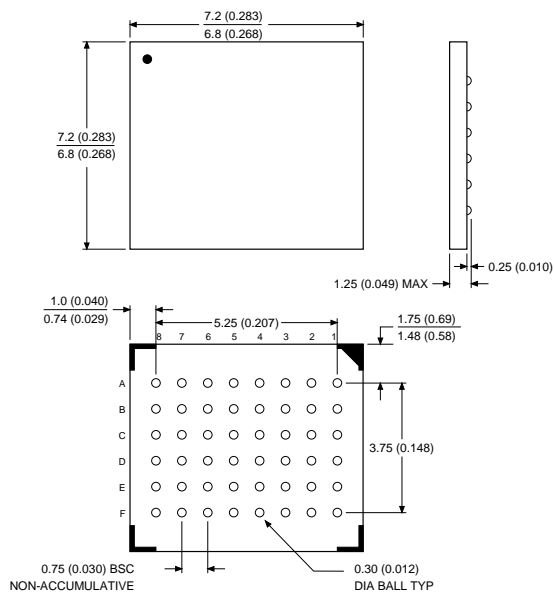

**44R**, 44-lead, 0.525" Wide, Plastic Gull Wing Small Outline Package (SOIC)  
 Dimensions in Inches and (Millimeters)

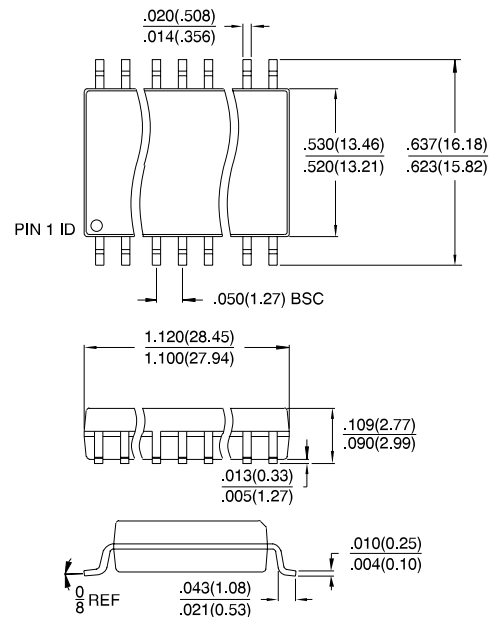



## Atmel Headquarters

### **Corporate Headquarters**

2325 Orchard Parkway  
San Jose, CA 95131  
TEL (408) 441-0311  
FAX (408) 487-2600

### **Europe**

Atmel U.K., Ltd.  
Coliseum Business Centre  
Riverside Way  
Camberley, Surrey GU15 3YL  
England  
TEL (44) 1276-686-677  
FAX (44) 1276-686-697

### **Asia**

Atmel Asia, Ltd.  
Room 1219  
Chinachem Golden Plaza  
77 Mody Road Tsimhatsui  
East Kowloon  
Hong Kong  
TEL (852) 2721-9778  
FAX (852) 2722-1369

### **Japan**

Atmel Japan K.K.  
9F, Tonetsu Shinkawa Bldg.  
1-24-8 Shinkawa  
Chuo-ku, Tokyo 104-0033  
Japan  
TEL (81) 3-3523-3551  
FAX (81) 3-3523-7581

## Atmel Operations

### **Atmel Colorado Springs**

1150 E. Cheyenne Mtn. Blvd.  
Colorado Springs, CO 80906  
TEL (719) 576-3300  
FAX (719) 540-1759

### **Atmel Rousset**

Zone Industrielle  
13106 Rousset Cedex  
France  
TEL (33) 4-4253-6000  
FAX (33) 4-4253-6001

---

### ***Fax-on-Demand***

North America:  
1-(800) 292-8635  
International:  
1-(408) 441-0732

### ***e-mail***

literature@atmel.com

### ***Web Site***

<http://www.atmel.com>

### ***BBS***

1-(408) 436-4309

#### © Atmel Corporation 1999.

Atmel Corporation makes no warranty for the use of its products, other than those expressly contained in the Company's standard warranty which is detailed in Atmel's Terms and Conditions located on the Company's web site. The Company assumes no responsibility for any errors which may appear in this document, reserves the right to change devices or specifications detailed herein at any time without notice, and does not make any commitment to update the information contained herein. No licenses to patents or other intellectual property of Atmel are granted by the Company in connection with the sale of Atmel products, expressly or by implication. Atmel's products are not authorized for use as critical components in life support devices or systems.

Marks bearing ® and/or ™ are registered trademarks and trademarks of Atmel Corporation.

Terms and product names in this document may be trademarks of others.



Printed on recycled paper.

1199D-08/99/xM

## Looking for pricing, stock, or lifecycle information?

Click below to explore more details on WIN SOURCE:

- ⊖ [View AT49F8192AT-70TC on WIN SOURCE](#)
- ⊖ [Atmel Information](#)

## Optimize Your Supply Chain with WIN SOURCE Solutions

- ✓ Global Sourcing Solution
- ✓ Obsolete Management
- ✓ Cost Control Management
- ✓ Shortage Management
- ✓ Alternative Solution
- ✓ Excess Inventory Management