



**THE DATASHEET OF
CC2564BYFVR**



CC256x Dual-Mode Bluetooth® Controller

CC2560A NRND; CC2564 NRND

1 Device Overview

1.1 Features

- TI's Single-Chip *Bluetooth* Solution With *Bluetooth* Basic Rate (BR), Enhanced Data Rate (EDR), and Low Energy (LE) Support; Available in Two Variants:
 - Dual-Mode *Bluetooth* CC2564 Controller
 - *Bluetooth* CC2560 Controller
- CC2564 *Bluetooth* 4.1 Controller Subsystem Qualified (QDID 58852); Compliant up to the HCI Layer
- Highly Optimized for Low-Cost Designs:
 - Single-Ended 50-Ω RF Interface
 - Package Footprint: 76 Terminals, 0.6-mm Pitch, 8-mm x 8-mm mrQFN
- BR/EDR Features Include:
 - Up to 7 Active Devices
 - Scatternet: Up to 3 Piconets Simultaneously, 1 as Master and 2 as Slaves
 - Up to 2 SCO Links on the Same Piconet
 - Support for All Voice Air-Coding – Continuously Variable Slope Delta (CVSD), A-Law, μ -Law, and Transparent (Uncoded)
 - CC2560B/CC2564B Devices Provide an Assisted Mode for HFP 1.6 Wideband Speech (WBS) Profile or A2DP Profile to Reduce Host Processing and Power
 - Support of Multiple *Bluetooth* Profiles With Enhanced QoS
- LE Features Include:
 - Support of Up to 10 (CC2564B) Connections
 - Multiple Sniff Instances Tightly Coupled to Achieve Minimum Power Consumption
 - Independent Buffering for LE Allows Large Numbers of Multiple Connections Without Affecting BR/EDR Performance.
 - Built-In Coexistence and Prioritization Handling for BR/EDR and LE
- Best-in-Class *Bluetooth* (RF) Performance
 - (TX Power, RX Sensitivity, Blocking)
 - Class 1 TX Power Up to +10 dBm
 - –95 dbm Typical RX Sensitivity
 - Internal Temperature Detection and Compensation to Ensure Minimal Variation in RF Performance Over Temperature, No External Calibration Required
 - Improved Adaptive Frequency Hopping (AFH) Algorithm With Minimum Adaptation Time
 - Provides Longer Range, Including 2x Range Over Other LE-Only Solutions
- Advanced Power Management for Extended Battery Life and Ease of Design
 - On-Chip Power Management, Including Direct Connection to Battery
 - Low Power Consumption for Active, Standby, and Scan *Bluetooth* Modes
 - Shutdown and Sleep Modes to Minimize Power Consumption
- Physical Interfaces:
 - UART Interface With Support for Maximum *Bluetooth* Data Rates
 - UART Transport Layer (H4) With Maximum Rate of 4 Mbps
 - Three-Wire UART Transport Layer (H5) With Maximum Rate of 4 Mbps (CC2560B and CC2564B Only)
 - Fully Programmable Digital PCM-I2S Codec Interface
- Flexibility for Easy Stack Integration and Validation Into Various Microcontrollers, Such as MSP430™ and ARM® Cortex®-M3 and Cortex®-M4 MCUs
- CC256x *Bluetooth* Hardware Evaluation Tool: PC-Based Application to Evaluate RF Performance of the Device and Configure Service Pack
- Device Pin-to-Pin Compatible With Previous Devices or Modules

1.2 Applications

- Mobile Accessories
- Sports and Fitness Applications
- Wireless Audio Solutions
- Remote Controls
- Toys
- Test and Measurement
- Industrial: Cable Replacement
- Wireless Sensors
- Automotive Aftermarket
- Point of Service (POS)
- Wellness and Health



1.3 Description

The TI CC256x device is a complete *Bluetooth* BR/EDR/LE HCI solution that reduces design effort and enables fast time to market. Based on TI's seventh-generation *Bluetooth* core, the CC256x device provides a product-proven solution that is *Bluetooth* 4.1 compliant. When coupled with a microcontroller unit (MCU), this HCI device offers best-in-class RF performance with a range of about 2X compared to other *Bluetooth* LE-only solutions. Furthermore, TI's power-management hardware and software algorithms provide significant power savings in all commonly used *Bluetooth* BR/EDR/LE modes of operation.

The TI Dual-Mode *Bluetooth* Stack software is certified and provided royalty free for TI's MSP430 and ARM Cortex-M3 and Cortex-M4 MCUs. Other MPUs can be supported through TI's third party. iPod® (MFi) protocol is supported by add-on software packages. For more information, see [TI Dual-Mode Bluetooth Stack](#). Some of the profiles supported include the following:

- Serial port profile (SPP)
- Advanced audio distribution profile (A2DP)
- Audio/video remote control profile (AVRCP)
- Handsfree profile (HFP)
- Human interface device (HID)
- Generic attribute profile (GATT)
- Several *Bluetooth* LE profiles and services

In addition to software, this solution consists of multiple reference designs with a low BOM cost, including a new *Bluetooth* audio sink reference design for customers to create a variety of applications for low-end, low-power audio solutions.

Device Information⁽¹⁾

PART NUMBER	PACKAGE	BODY SIZE
CC2560A (NRND) ⁽²⁾	RVM (76)	8.0 mm × 8.0 mm × 0.6 mm
CC2560B	RVM (76)	8.0 mm × 8.0 mm × 0.6 mm
CC2564 (NRND) ⁽²⁾	RVM (76)	8.0 mm × 8.0 mm × 0.6 mm
CC2564B	RVM (76)	8.0 mm × 8.0 mm × 0.6 mm

(1) For more information on these devices, see [Section 9.2, Packaging and Ordering](#).

(2) NRND = Not recommended for new designs

1.4 Functional Block Diagram

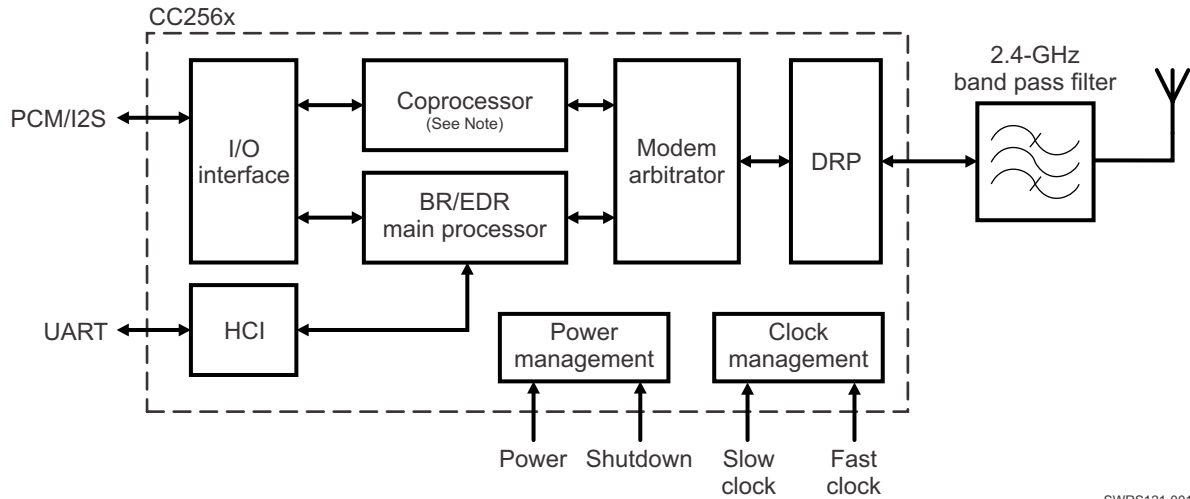

SWRS121-001

Note: The following technologies and assisted modes cannot be used simultaneously with the coprocessor: *Bluetooth* LE, ANT, assisted HFP 1.6 (WBS), and assisted A2DP. One and only one technology or assisted mode can be used at a time.

Figure 1-1. Functional Block Diagram

Table of Contents

1	Device Overview	1	6.3	Clock Inputs	21
1.1	Features	1	6.4	Functional Blocks.....	24
1.2	Applications.....	1	6.5	<i>Bluetooth</i> BR/EDR Features	34
1.3	Description.....	2	6.6	<i>Bluetooth</i> LE Description.....	35
1.4	Functional Block Diagram	3	6.7	<i>Bluetooth</i> Transport Layers	36
2	Revision History	4	6.8	Changes from CC2560A and CC2564 to CC2560B and CC2564B Devices	36
3	Device Comparison	5	7	Applications, Implementation, and Layout	37
4	Terminal Configuration and Functions	6	7.1	Reference Design Schematics and BOM for Power and Radio Connections	37
4.1	Pin Attributes	7	8	Device and Documentation Support	38
4.2	Connections for Unused Signals	8	8.1	Device Support	38
5	Specifications	9	8.2	Documentation Support	38
5.1	Absolute Maximum Ratings	9	8.3	Related Links.....	38
5.2	ESD Ratings.....	9	8.4	Community Resources	39
5.3	Power-On Hours.....	9	8.5	Trademarks.....	39
5.4	Recommended Operating Conditions	9	8.6	Electrostatic Discharge Caution.....	39
5.5	Power Consumption Summary.....	10	8.7	Glossary	39
5.6	Electrical Characteristics	11	9	Mechanical, Packaging, and Orderable Information	40
5.7	Timing and Switching Characteristics	12	9.1	mrQFN Mechanical Data.....	40
6	Detailed Description	21	9.2	Packaging and Ordering	42
6.1	Overview	21			
6.2	Functional Block Diagram.....	21			

2 Revision History

Changes from Revision D (January 2014) to Revision E	Page
• Changed organizational flow of document in compliance with Data Sheet Council standard	1
• Changed document title	1
• Changed Section 1.1, Features	1
• Changed Section 1.3, Description	2
• Changed Device Information table	2
• Added Section 5.2, ESD Ratings	9
• Changed values for continuous transmission for GFSK and EDR in Section 5.5.1, Static Current Consumption	10
• Deleted idle mode in Section 5.5.1, Static Current Consumption	10
• Changed values for average current in Section 5.5.2.2, Current Consumption for Different LE Scenarios	11
• Added supported crystal frequency in Section 6.3.2.3, Fast Clock Using External Crystal	24
• Changed Section 6.4.4, Assisted Modes (CC2560B and CC2564B Devices)	30
• Added dual channel support in Table 6-5	32
• Added 4, 8, and 12 block lengths in Table 6-7	32
• Added 4 subband support in Table 6-8	32
• Added SNR support in Table 6-9	32
• Added Assisted A2DP sink range of 2–54 in Table 6-10	32
• Changed Section 6.5, Bluetooth BR/EDR Description	34
• Changed Section 6.6, Bluetooth LE Description	35
• Changed Figure 7-1	37
• Changed description of 0.1- μ F and 1.0- μ F capacitors and of reference designators C31 and U5 and in Table 7-1 ..	37
• Changed A1 corner orientation in Figure 9-3	43

3 Device Comparison

Table 3-1 lists the features of the CC256x device variants.

Table 3-1. CC256x Family Members

DEVICE	DESCRIPTION	TECHNOLOGY SUPPORTED			ASSISTED MODES SUPPORTED ⁽¹⁾	
		BR/EDR	LE	ANT	HFP 1.6 (WBS)	A2DP
CC2560A (NRND) ⁽²⁾	Bluetooth 4.0 (with EDR)	√				
CC2564 (NRND) ⁽²⁾⁽³⁾	Bluetooth 4.0 + BLE	√	√			
	Bluetooth 4.0 + ANT	√		√		
CC2560B	Bluetooth 4.1 (with EDR)	√			√	√
CC2564B ⁽³⁾	Bluetooth 4.1 + BLE	√	√		√	√
	Bluetooth 4.1 + ANT	√		√	√	√

(1) The assisted modes (HFP 1.6 and A2DP) are not supported simultaneously. Furthermore, the assisted modes are not supported simultaneously with BLE or ANT.

(2) NRND = Not recommended for new designs

(3) Does not support simultaneous operation of LE and ANT

4 Terminal Configuration and Functions

Figure 4-1 shows the bottom view of the pin attributes.

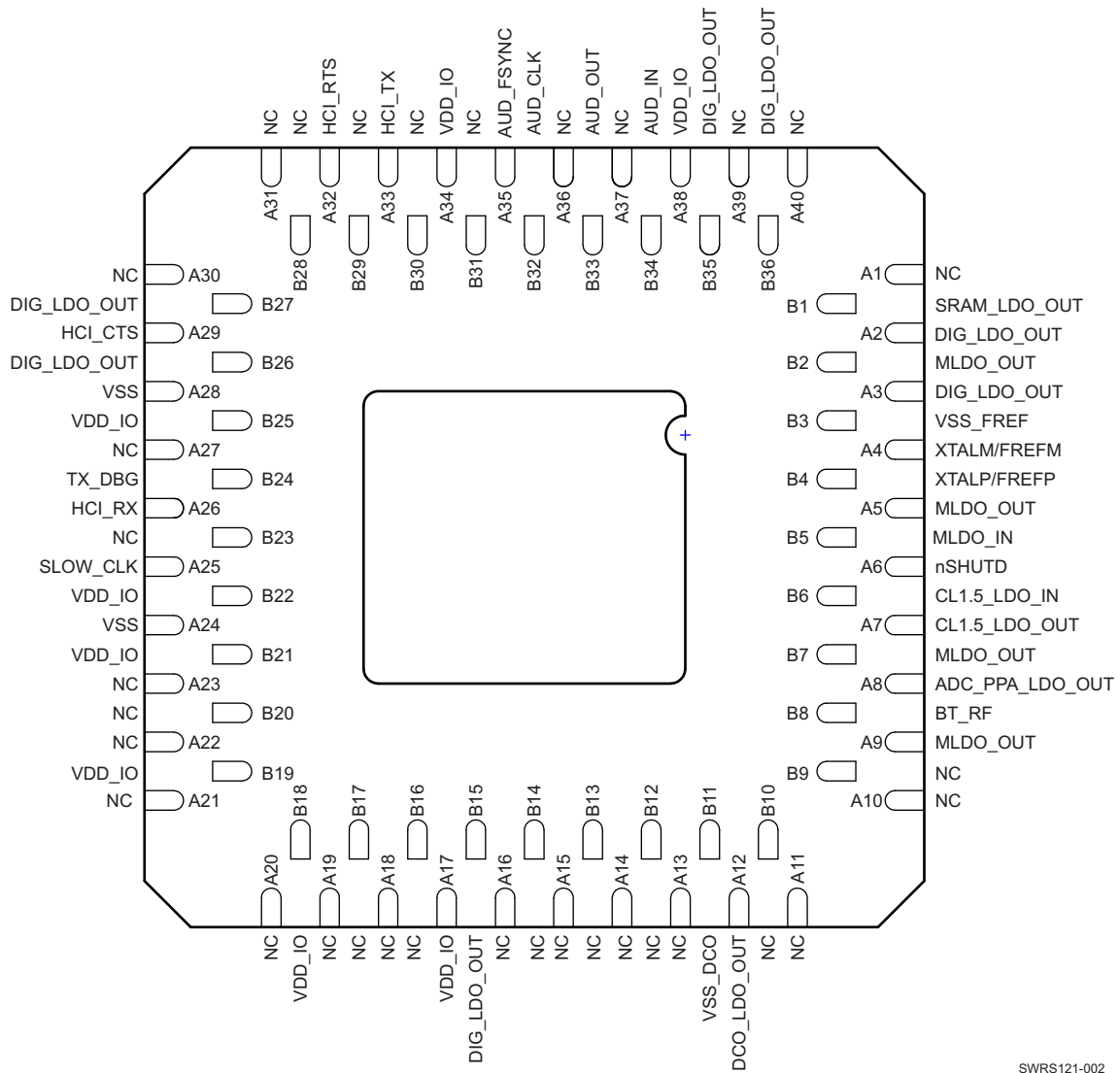

Figure 4-1. Pin Diagram (Bottom View)

SWRS121-002

4.1 Pin Attributes

Table 4-1 describes the pin attributes.

Table 4-1. Pin Attributes

NAME	NO.	PULL AT RESET	DEF. DIR. ⁽¹⁾	I/O Type ⁽²⁾	DESCRIPTION	
I/O Signals						
HCI_RX	A26	PU	I	8 mA	HCI universal asynchronous receiver/transmitter (UART) data receive	
HCI_TX	A33	PU	O	8 mA	HCI UART data transmit	
HCI_RTS	A32	PU	O	8 mA	HCI UART request-to-send The host is allowed to send data when HCI_RTS is low.	
HCI_CTS	A29	PU	I	8 mA	HCI UART clear-to-send The CC256x device is allowed to send data when HCI_CTS is low.	
AUD_FSYNC	A35	PD	I/O	4 mA	pulse-code modulation (PCM) frame-sync signal	Fail-safe
AUD_CLK	B32	PD	I/O	HY, 4 mA	PCM clock	Fail-safe
AUD_IN	B34	PD	I	4 mA	PCM data input	Fail-safe
AUD_OUT	B33	PD	O	4 mA	PCM data output	Fail-safe
TX_DBG	B24	PU	O	2 mA	TI internal debug messages. TI recommends leaving an internal test point.	
Clock Signals						
SLOW_CLK	A25		I		32.768-kHz clock in	Fail-safe
XTALP/FREFP	B4		I		Fast clock in analog (sine wave) Output terminal of fast-clock crystal	Fail-safe
XTALM/FREFM	A4		I		Fast clock in digital (square wave) Input terminal of fast-clock crystal	Fail-safe
Analog Signals						
BT_RF	B8		I/O		Bluetooth RF I/O	
nSHUTD	A6	PD	I		Shutdown input (active low)	
Power and Ground Signals						
VDD_IO	A17, A34, A38, B18, B19, B21, B22, B25		I		I/O power supply (1.8-V nominal)	
MLDO_IN	B5		I		Main LDO input Connect directly to battery	
MLDO_OUT	A5, A9, B2, B7		I/O		Main LDO output (1.8-V nominal)	
CL1.5_LDO_IN	B6		I		Power amplifier (PA) LDO input Connect directly to battery	
CL1.5_LDO_OUT	A7		O		PA LDO output	
DIG_LDO_OUT	A2, A3, B15, B26, B27, B35, B36		O		Digital LDO output QFN pin B26 or B27 must be shorted to other DIG_LDO_OUT pins on the PCB.	
SRAM_LDO_OUT	B1		O		SRAM LDO output	
DCO_LDO_OUT	A12		O		DCO LDO output	
ADC_PPA_LDO_OUT	A8		O		ADC/PPA LDO output	

(1) I = input; O = output; I/O = bidirectional

(2) I/O Type: Digital I/O cells. HY = input hysteresis, current = typical output current

Table 4-1. Pin Attributes (continued)

NAME	NO.	PULL AT RESET	DEF. DIR. ⁽¹⁾	I/O Type ⁽²⁾	DESCRIPTION
VSS	A24, A28		I		Ground
VSS_DCO	B11		I		DCO ground
VSS_FREF	B3		I		Fast clock ground

4.2 Connections for Unused Signals

Table 4-2 lists the connections for unused signals.

Table 4-2. Connections for Unused Signals

FUNCTION	PIN NUMBER	DESCRIPTION
NC	A1	Not connected
NC	A10	Not connected
NC	A11	Not connected
NC	A14	Not connected
NC	A18	Not connected
NC	A19	Not connected
NC	A20	Not connected
NC	A21	Not connected
NC	A22	Not connected
NC	A23	Not connected
NC	A27	Not connected
NC	A30	Not connected
NC	A31	Not connected
NC	A40	Not connected
NC	B9	Not connected
NC	B10	Not connected
NC	B16	Not connected
NC	B17	Not connected
NC	B20	Not connected
NC	B23	Not connected
NC	A13	TI internal use
NC	A15	TI internal use
NC	A16	TI internal use
NC	A36	TI internal use
NC	A37	TI internal use
NC	A39	TI internal use
NC	B12	TI internal use
NC	B13	TI internal use
NC	B14	TI internal use
NC	B29	TI internal use
NC	B30	TI internal use
NC	B31	TI internal use
NC	B28	TI internal use

5 Specifications

Unless otherwise indicated, all measurements are taken at the device pins of the TI test evaluation board (EVB). All specifications are over process, voltage, and temperature, unless otherwise indicated.

5.1 Absolute Maximum Ratings⁽¹⁾

Over operating free-air temperature range (unless otherwise indicated). All parameters are measured as follows: VDD_IN = 3.6 V and VDD_IO = 1.8 V (unless otherwise indicated).

PARAMETERS		MIN	MAX	UNIT
Supply voltage range	VDD_IN	-0.5	4.8	V ⁽¹⁾
	VDDIO_1.8V	-0.5	2.145	V
Input voltage to analog pins ⁽²⁾		-0.5	2.1	V
Input voltage to all other pins		-0.5	VDD_IO + 0.5	V
Bluetooth RF inputs			10	dBm
Operating ambient temperature range, T _A ⁽³⁾		-40	85	°C
Storage temperature range, T _{stg}		-55	125	°C

- (1) Stresses beyond those listed under absolute maximum ratings may cause permanent damage to the device. These are stress ratings only and functional operation of the device at these or any other conditions beyond those indicated under recommended operating conditions is not implied. Exposure to absolute-maximum-rated conditions for extended periods may affect device reliability.
- (1) Maximum allowed depends on accumulated time at that voltage: VDD_IN is defined in [Section 7.1, Reference Design for Power and Radio Connections](#).
- (2) Analog pins: BT_RF, XTALP, and XTALM
- (3) The reference design supports a temperature range of -20°C to 70°C because of the operating conditions of the crystal.

5.2 ESD Ratings

		VALUE	UNIT
V _(ESD) electrostatic discharge	Human-body model (HBM), per ANSI/ESDA/JEDEC JS-001 ⁽¹⁾	±500	V
	Charged device model (CDM), per JEDEC specification JESD22- ±YYY V C101 ⁽²⁾	±250	

- (1) JEDEC document JEP155 states that 500-V HBM allows safe manufacturing with a standard ESD control process.
- (2) JEDEC document JEP157 states that 250-V CDM allows safe manufacturing with a standard ESD control process.

5.3 Power-On Hours

DEVICE	CONDITIONS	POWER-ON HOURS
CC256x	Duty cycle = 25% active and 75% sleep T _{ambient} = 70°C	15,400 (7 Years)

5.4 Recommended Operating Conditions

RATING	CONDITION	SYM	MIN	MAX	UNIT
Power supply voltage		VDD_IN	2.2	4.8	V
I/O power supply voltage		VDD_IO	1.62	1.92	V
High-level input voltage	Default	V _{IH}	0.65 x VDD_IO	VDD_IO	V
Low-level input voltage	Default	V _{IL}	0	0.35 x VDD_IO	V
I/O input rise and all times, 10% to 90% — asynchronous mode		t _r and t _f	1	10	ns
I/O input rise and fall times, 10% to 90% — synchronous mode (PCM)			1	2.5	ns
Voltage dips on VDD_IN (V _{BAT}) duration = 577 μs to 2.31 ms, period = 4.6 ms				400	mV
Maximum ambient operating temperature ^{(1) (2)}			-40	85	°C

- (1) The device can be reliably operated for 7 years at T_{ambient} of 85°C, assuming 25% active mode and 75% sleep mode (15,400 cumulative active power-on hours).
- (2) A crystal-based solution is limited by the temperature range required for the crystal to meet 20 ppm.

5.5 Power Consumption Summary

5.5.1 Static Current Consumption

OPERATIONAL MODE	MIN	TYP	MAX	UNIT
Shutdown mode ⁽¹⁾		1	7	μA
Deep sleep mode ⁽²⁾		40	105	μA
Total I/O current consumption in active mode			1	mA
Continuous transmission—GFSK ⁽³⁾			107	mA
Continuous transmission—EDR ⁽⁴⁾⁽⁵⁾			112.5	mA

(1) $V_{BAT} + V_{IO} + V_{SHUTDOWN}$

(2) $V_{BAT} + V_{IO}$

(3) At maximum output power (10 dBm)

(4) At maximum output power (8 dBm)

(5) Both $\pi/4$ DQPSK and 8DPSK

5.5.2 Dynamic Current Consumption

5.5.2.1 Current Consumption for Different Bluetooth BR/EDR Scenarios

Conditions: VDD_IN = 3.6 V, 25°C, 26-MHz XTAL, nominal unit, 10-dBm output power

OPERATIONAL MODE	MASTER AND SLAVE	AVERAGE CURRENT	UNIT
Synchronous connection oriented (SCO) link HV3	Master and slave	13.7	mA
Extended SCO (eSCO) link EV3 64 kbps, no retransmission	Master and slave	13.2	mA
eSCO link 2-EV3 64 kbps, no retransmission	Master and slave	10	mA
GFSK full throughput: TX = DH1, RX = DH5	Master and slave	40.5	mA
EDR full throughput: TX = 2-DH1, RX = 2-DH5	Master and slave	41.2	mA
EDR full throughput: TX = 3-DH1, RX = 3-DH5	Master and slave	41.2	mA
Sniff, four attempt, 1.28 seconds	Master and slave	145	μA
Page or inquiry scan 1.28 seconds, 11.25 ms	Master and slave	320	μA
Page (1.28 seconds) and inquiry (2.56 seconds) scans, 11.25 ms	Master and slave	445	μA
A2DP source	Master	13.9	mA
A2DP sink	Master	15.2	mA
Assisted A2DP source	Master	16.9	mA
Assisted A2DP sink	Master	18.1	mA
Assisted WBS EV3; retransmit effort = 2; maximum latency = 8 ms	Master and slave	17.5 and 18.5	mA
Assisted WBS 2EV3; retransmit effort = 2; maximum latency = 12 ms	Master and slave	11.9 and 13	mA

5.5.2.2 Current Consumption for Different LE Scenarios

Conditions: VDD_IN = 3.6 V, 25°C, 26-MHz fast clock, nominal unit, 10-dBm output power

MODE		DESCRIPTION	AVERAGE CURRENT	UNIT
Advertising, nonconnectable		Advertising in all three channels 1.28-seconds advertising interval 15 bytes advertise data	114	μA
Advertising, discoverable		Advertising in all three channels 1.28-seconds advertising interval 15 bytes advertise data	138	μA
Scanning		Listening to a single frequency per window 1.28-seconds scan interval 11.25-ms scan window	324	μA
Connected	Master role	500-ms connection interval	169	μA
	Slave role	0-ms slave connection latency Empty TX and RX LL packets	199	

5.6 Electrical Characteristics

RATING		CONDITION	MIN	MAX	UNIT	
High-level output voltage, V _{OH}		At 2, 4, 8 mA	0.8 x VDD_IO	VDD_IO	V	
		At 0.1 mA	VDD_IO – 0.2	VDD_IO		
Low-level output voltage, V _{OL}		At 2, 4, 8 mA	0	0.2 x VDD_IO	V	
		At 0.1 mA	0	0.2		
I/O input impedance		Resistance	1		MΩ	
		Capacitance		5	pF	
Output rise and fall times, 10% to 90% (digital pins)		C _L = 20 pF		10	ns	
I/O pull currents	PCM-I2S bus, TX_DBG	PU	typ = 6.5	3.5	9.7	μA
		PD	typ = 27	9.5	55	
	All others	PU	typ = 100	50	300	
		PD	typ = 100	50	360	

5.7 Timing and Switching Characteristics

5.7.1 Device Power Supply

The CC256x power-management hardware and software algorithms provide significant power savings, which is a critical parameter in an MCU-based system.

The power-management module is optimized for drawing extremely low currents.

5.7.1.1 Power Sources

The CC256x device requires two power sources:

- VDD_IN: main power supply for the device
- VDD_IO: power source for the 1.8-V I/O ring

The HCI module includes several on-chip voltage regulators for increased noise immunity and can be connected directly to the battery.

5.7.1.2 Device Power-Up and Power-Down Sequencing

The device includes the following power-up requirements (see [Figure 5-1](#)):

- nSHUTD must be low. VDD_IN and VDD_IO are don't-care when nSHUTD is low. However, signals are not allowed on the I/O pins if I/O power is not supplied, because the I/Os are not fail-safe. Exceptions are SLOW_CLK_IN and AUD_xxx, which are fail-safe and can tolerate external voltages with no VDD_IO and VDD_IN.
- VDD_IO and VDD_IN must be stable before releasing nSHUTD.
- The fast clock must be stable within 20 ms of nSHUTD going high.
- The slow clock must be stable within 2 ms of nSHUTD going high.

The device indicates that the power-up sequence is complete by asserting RTS low, which occurs up to 100 ms after nSHUTD goes high. If RTS does not go low, the device is not powered up. In this case, ensure that the sequence and requirements are met.

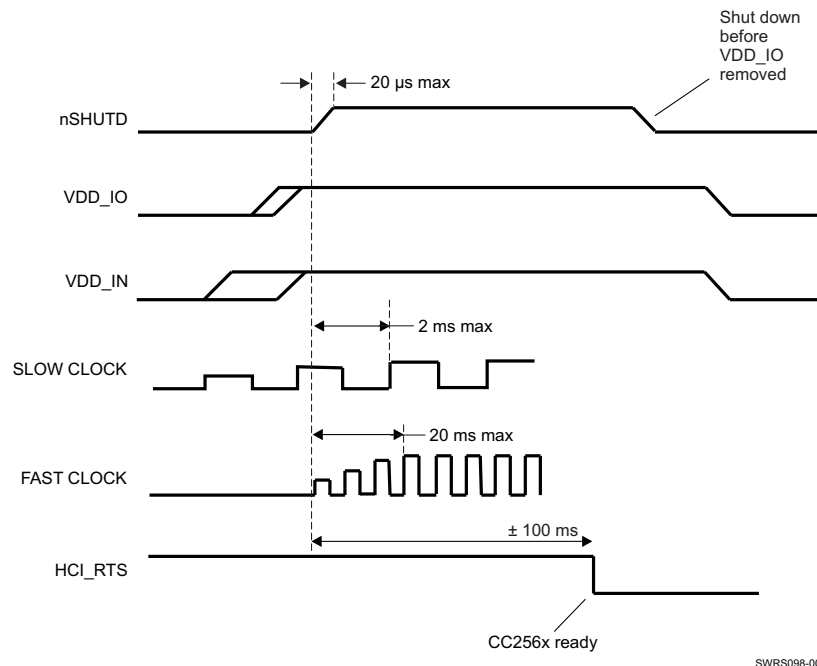

Figure 5-1. Power-Up and Power-Down Sequence

5.7.1.3 Power Supplies and Shutdown – Static States

The nSHUTD signal puts the device in ultra-low power mode and performs an internal reset to the device. The rise time for nSHUTD must not exceed 20 μ s; nSHUTD must be low for a minimum of 5 ms.

To prevent conflicts with external signals, all I/O pins are set to the high-impedance (Hi-Z) state during shutdown and power up of the device. The internal pull resistors are enabled on each I/O pin, as described in [Section 4.1, Pin Attributes](#). [Table 5-1](#) describes the static operation states.

Table 5-1. Power Modes

	VDD_IN ⁽¹⁾	VDD_IO ⁽¹⁾	nSHUTD ⁽¹⁾	PM_MODE	COMMENTS
1	None	None	Asserted	Shut down	I/O state is undefined. No I/O voltages are allowed on nonfail-safe pins.
2	None	None	Deasserted	Not allowed	I/O state is undefined. No I/O voltages are allowed on nonfail-safe pins.
3	None	Present	Asserted	Shut down	I/Os are defined as 3-state with internal pullup or pulldown enabled.
4	None	Present	Deasserted	Not allowed	I/O state is undefined. No I/O voltages are allowed on nonfail-safe pins.
5	Present	None	Asserted	Shut down	I/O state is undefined.
6	Present	None	Deasserted	Not allowed	I/O state is undefined. No I/O voltages are allowed on nonfail-safe pins.
7	Present	Present	Asserted	Shut down	I/Os are defined as 3-state with internal pullup or pulldown enabled.
8	Present	Present	Deasserted	Active	See Section 5.7.1.4, I/O States in Various Power Modes

(1) The terms *None* or *Asserted* can imply any of the following conditions: directly pulled to ground or driven low, pulled to ground through a pulldown resistor, or left NC or floating (high-impedance output stage).

5.7.1.4 I/O States in Various Power Modes

CAUTION

Some device I/Os are not fail-safe (see [Section 4.1, Pin Attributes](#)). Fail-safe means that the pins do not draw current from an external voltage applied to the pin when I/O power is not supplied to the device. External voltages are not allowed on these I/O pins when the I/O supply voltage is not supplied because of possible damage to the device.

[Table 5-2](#) lists the I/O states in various power modes.

Table 5-2. I/O States in Various Power Modes

I/O NAME	SHUT DOWN ⁽¹⁾		DEFAULT ACTIVE ⁽¹⁾		DEEP SLEEP ⁽¹⁾	
	I/O State	Pull	I/O State	Pull	I/O State	Pull
HCI_RX	Z	PU	I	PU	I	PU
HCI_TX	Z	PU	O-H		O	
HCI_RTS	Z	PU	O-H		O	
HCI_CTS	Z	PU	I	PU	I	PU
AUD_CLK	Z	PD	I	PD	I	PD
AUD_FSYNC	Z	PD	I	PD	I	PD
AUD_IN	Z	PD	I	PD	I	PD
AUD_OUT	Z	PD	Z	PD	Z	PD
TX_DBG	Z	PU	O			

(1) I = input, O = output, Z = Hi-Z, — = no pull, PU = pullup, PD = pulldown, H = high, L = low

5.7.1.5 nSHUTD Requirements

PARAMETER	SYM	MIN	MAX	UNIT
Operation mode level ⁽¹⁾	V _{IH}	1.42	1.98	V
Shutdown mode level ⁽¹⁾	V _{IL}	0	0.4	V
Minimum time for nSHUT_DOWN low to reset the device		5		ms
Rise and fall times	t _r and t _f		20	μs

(1) An internal pulldown retains shut-down mode when no external signal is applied to this pin.

5.7.2 Clock Specifications

5.7.2.1 Slow Clock Requirements

An external source must supply the slow clock and connect to the SLOW_CLK_IN pin (for example, the host or external crystal oscillator). The source must be a digital signal in the range of 0 to 1.8 V. The accuracy of the slow clock frequency must be 32.768 kHz ±250 ppm for *Bluetooth* use (as specified in the *Bluetooth* specification). The external slow clock must be stable within 64 slow-clock cycles (2 ms) following the release of nSHUTD.

CHARACTERISTICS	CONDITION	SYM	MIN	TYP	MAX	UNIT
Input slow clock frequency			32768			Hz
Input slow clock accuracy (Initial + temp + aging)	<i>Bluetooth</i>		±250			ppm
	ANT		±50			
Input transition time t _r and t _f (10% to 90%)		t _r and t _f	200			ns
Frequency input duty cycle			15%	50%	85%	
Slow clock input voltage limits	Square wave, DC-coupled	V _{IH}	0.65 × VDD_IO		VDD_IO	V peak
		V _{IL}	0		0.35 × VDD_IO	V peak
Input impedance			1			MΩ
Input capacitance			5			pF

5.7.2.2 External Fast Clock Crystal Requirements and Operation

CHARACTERISTICS	CONDITION	SYM	MIN	TYP	MAX	UNIT
Supported crystal frequencies		f _{in}	26, 38.4			MHz
Frequency accuracy (Initial + temperature + aging)			±20			ppm
Crystal oscillator negative resistance	26 MHz, external capacitance = 8 pF I _{osc} = 0.5 mA		650	940		Ω
	26 MHz, external capacitance = 20 pF I _{osc} = 2.2 mA		490	710		

5.7.2.3 Fast Clock Source Requirements (–40°C to +85°C)

CHARACTERISTICS	CONDITION	SYM	MIN	TYP	MAX	UNIT
Supported frequencies		F _{REF}	26, 38.4			MHz
Reference frequency accuracy	Initial + temp + aging		±20			ppm
Fast clock input voltage limits	Square wave, DC-coupled	V _{IL}	–0.2		0.37	V
		V _{IH}	1.0		2.1	V
	Sine wave, AC-coupled		0.4		1.6	V _{p-p}
	Sine wave, DC-coupled		0.4		1.6	V _{p-p}
	Sine wave input limits, DC-coupled		0.0		1.6	V

CHARACTERISTICS	CONDITION	SYM	MIN	TYP	MAX	UNIT
Fast clock input rise time (as % of clock period)	Square wave, DC-coupled				10%	
Duty cycle			35%	50%	65%	
Phase noise for 26 MHz	@ offset = 1 kHz				-123.4	dBc/Hz
	@ offset = 10 kHz				-133.4	
	@ offset = 100 kHz				-138.4	

5.7.3 Peripherals

5.7.3.1 UART

Figure 5-2 shows the UART timing diagram.

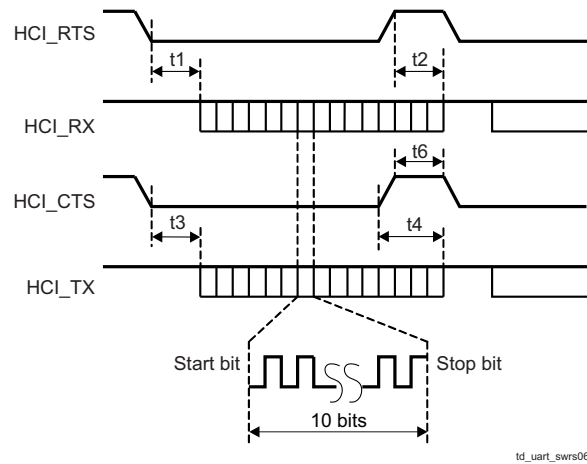

Figure 5-2. UART Timing

Table 5-3 lists the UART timing characteristics.

Table 5-3. UART Timing Characteristics

SYMBOL	CHARACTERISTICS	CONDITION	MIN	TYP	MAX	UNIT
	Baud rate		37.5		4000	kbps
	Baud rate accuracy per byte	Receive and transmit	-2.5%		1.5%	
	Baud rate accuracy per bit	Receive and transmit	-12.5%		12.5%	
t3	CTS low to TX_DATA on		0	2		μs
t4	CTS high to TX_DATA off	Hardware flow control			1	byte
t6	CTS-high pulse width		1			bit
t1	RTS low to RX_DATA on		0	2		μs
t2	RTS high to RX_DATA off	Interrupt set to 1/4 FIFO			16	byte

Figure 5-3 shows the UART data frame.

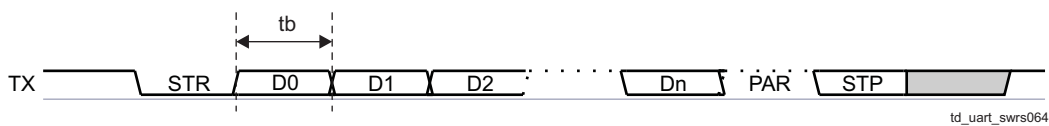

Figure 5-3. Data Frame

Table 5-4 describes the symbols used in Figure 5-3.

Table 5-4. Data Frame Key

SYMBOL	DESCRIPTION
STR	Start bit
D0...Dn	Data bits (LSB first)
PAR	Parity bit (optional)
STP	Stop bit

5.7.3.2 PCM

Figure 5-4 shows the interface timing for the PCM.

**Figure 5-4. PCM Interface Timing**

Table 5-5 lists the associated PCM master parameters.

Table 5-5. PCM Master

Symbol	PARAMETER	CONDITION	MIN	MAX	UNIT
T_{clk}	Cycle time		244.14 (4.096 MHz)	15625 (64 kHz)	ns
T_w	High or low pulse width		50% of T_{clk} min		ns
t_{is}	AUD_IN setup time		25		ns
t_{ih}	AUD_IN hold time		0		ns
t_{op}	AUD_OUT propagation time	40-pF load	0	10	ns
t_{op}	FSYNC_OUT propagation time	40-pF load	0	10	ns

Table 5-6 lists the associated PCM slave parameters.

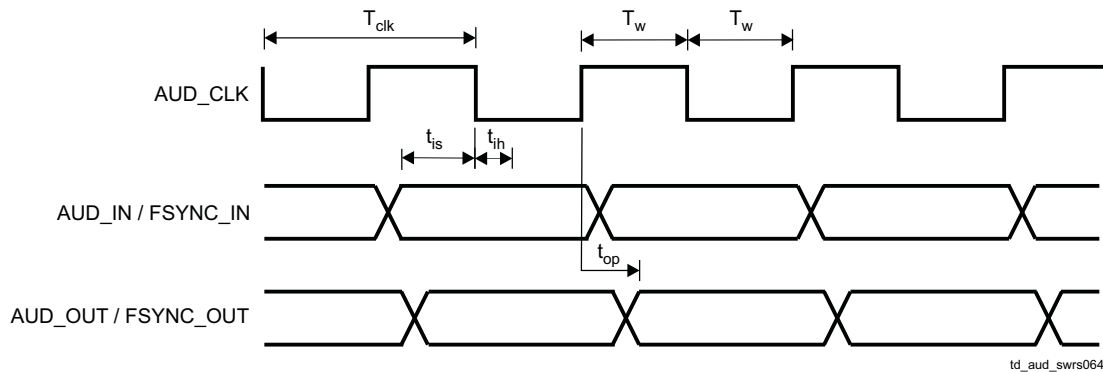
Table 5-6. PCM Slave

SYMBOL	PARAMETER	CONDITION	MIN	MAX	UNIT
T_{clk}	Cycle time		66.67 (15 MHz)		ns
T_w	High or low pulse width		40% of T_{clk}		ns
T_{is}	AUD_IN setup time		8		ns
T_{ih}	AUD_IN hold time		0		ns
t_{is}	AUD_FSYNC setup time		8		ns
t_{ih}	AUD_FSYNC hold time		0		ns
t_{op}	AUD_OUT propagation time	40-pF load	0	21	ns

5.7.4 RF Performance

5.7.4.1 Bluetooth BR/EDR RF Performance

All parameters in this section that are fast-clock dependent are verified using a 26-MHz XTAL under a temperature range from –20°C to 70°C and an RF load of 50 Ω at the BT_RF port.

5.7.4.1.1 Bluetooth Receiver—In-Band Signals

CHARACTERISTICS	CONDITION		MIN	TYP	MAX	BLUETOOTH SPECIFICATION	UNIT
Operation frequency range			2402		2480		MHz
Channel spacing				1			MHz
Input impedance				50			Ω
Sensitivity, dirty TX on ⁽¹⁾	GFSK, BER = 0.1%		–91.5	–95		–70	dBm
	Pi/4-DQPSK, BER = 0.01%		–90.5	–94.5		–70	
	8DPSK, BER = 0.01%		–81	–87.5		–70	
BER error floor at sensitivity + 10dB, dirty TX off	Pi/4-DQPSK		1E–6	1E–7		1E–5	
	8DPSK		1E–6			1E–5	
Maximum usable input power	GFSK, BER = 0.1%		–5			–20	dBm
	Pi/4-DQPSK, BER = 0.1%		–10				
	8DPSK, BER = 0.1%		–10				
Intermodulation characteristics	Level of interferers (for n = 3, 4, and 5)		–36	–30		–39	dBm
C/I performance ⁽²⁾ Image = –1 MHz	GFSK, co-channel			8	10	11	dB
	EDR, co-channel	Pi/4-DQPSK		9.5	11	13	
		8DPSK		16.5	20	21	
	GFSK, adjacent ±1 MHz			–10	–5	0	
	EDR, adjacent ±1 MHz, (image)	Pi/4-DQPSK		–10	–5	0	
		8DPSK		–5	–1	5	
	GFSK, adjacent +2 MHz			–38	–35	–30	
	EDR, adjacent, +2 MHz	Pi/4-DQPSK		–38	–35	–30	
		8DPSK		–38	–30	–25	
	GFSK, adjacent –2 MHz			–28	–20	–20	
	EDR, adjacent –2 MHz	Pi/4-DQPSK		–28	–20	–20	
		8DPSK		–22	–13	–13	
	GFSK, adjacent ≥ ±3 MHz			–45	–43	–40	
	EDR, adjacent ≥ ±3 MHz	Pi/4-DQPSK		–45	–43	–40	
		8DPSK		–44	–36	–33	
RF return loss				–10			dB
RX mode LO leakage	Frf = (received RF – 0.6 MHz)			–63	–58		dBm

(1) Sensitivity degradation up to 3 dB may occur for minimum and typical values where the *Bluetooth* frequency is a harmonic of the fast clock.

(2) Numbers show ratio of desired signal to interfering signal. Smaller numbers indicate better C/I performance.

5.7.4.1.2 Bluetooth Receiver—General Blocking

CHARACTERISTICS	CONDITION	MIN	TYP	UNIT
Blocking performance over full range, according to <i>Bluetooth</i> specification ⁽¹⁾	30 to 2000 MHz		–6	dBm
	2000 to 2399 MHz		–6	
	2484 to 3000 MHz		–6	
	3 to 12.75 GHz		–6	

(1) Exceptions are taken out of the total 24 allowed in the *Bluetooth* specification.

5.7.4.1.3 Bluetooth Transmitter—GFSK

CHARACTERISTICS	MIN	TYP	MAX	BLUETOOTH SPECIFICATION	UNIT
Maximum RF output power ⁽¹⁾	10	12			dBm
Power variation over <i>Bluetooth</i> band	-1		1		dB
Gain control range		30			dB
Power control step	2	5	8	2 to 8	
Adjacent channel power M-N = 2		-45	-39	≤ -20	dBm
Adjacent channel power M-N > 2		-50	-42	≤ -40	

(1) To modify maximum output power, use an HCI VS command.

5.7.4.1.4 Bluetooth Transmitter—EDR

CHARACTERISTICS		MIN	TYP	MAX	BLUETOOTH SPECIFICATION	UNIT
Maximum RF output power ⁽¹⁾	Pi/4-DQPSK	6	8			dBm
	8DPSK	6	8			
Relative power		-2		1	-4 to +1	dB
Power variation over <i>Bluetooth</i> band		-1		1		dB
Gain control range			30			dB
Power control step		2	5	8	2 to 8	dB
Adjacent channel power M-N = 1			-36	-30	≤ -26	dBc
Adjacent channel power M-N = 2 ⁽²⁾			-30	-23	≤ -20	dBm
Adjacent channel power M-N > 2 ⁽²⁾			-42	-40	≤ -40	dBm

(1) To modify maximum output power, use an HCI VS command.

(2) Assumes 3-dB insertion loss from *Bluetooth* RF ball to antenna

5.7.4.1.5 Bluetooth Modulation—GFSK

CHARACTERISTICS	CONDITION		SYM	MIN	TYP	MAX	BLUETOOTH SPECIFICATION	UNIT
-20 dB bandwidth	GFSK				925	995	≤ 1000	kHz
Modulation characteristics	Δf1avg	Mod data = 4 1 s, 4 0 s: 111100001111...	F1 avg	150	165	170	140 to 175	kHz
	Δf2max ≥ limit for at least 99.9% of all Δf2max	Mod data = 1010101...	F2 max	115	130		> 115	kHz
	Δf2avg, Δf1avg				85%	88%		> 80%
Absolute carrier frequency drift	DH1			-25		25	< ±25	kHz
	DH3 and DH5			-35		35	< ±40	
Drift rate						15	< 20	kHz/ 50 μs
Initial carrier frequency tolerance	f0 – fTX			-75		+75	< ±75	kHz

5.7.4.1.6 Bluetooth Modulation—EDR

CHARACTERISTICS	CONDITION	MIN	TYP	MAX	BLUETOOTH SPECIFICATION	UNIT
Carrier frequency stability				±5	≤ 10	kHz
Initial carrier frequency tolerance				±75	±75	kHz
RMS DEVM ⁽¹⁾	Pi/4-DQPSK		6%	15%	20%	
	8DPSK		6%	13%	13%	
99% DEVM ⁽¹⁾	Pi/4-DQPSK			30%	30%	
	8DPSK			20%	20%	
Peak DEVM ⁽¹⁾	Pi/4-DQPSK		14%	30%	35%	
	8DPSK		16%	25%	25%	

(1) Max performance refers to maximum TX power.

5.7.4.1.7 Bluetooth Transmitter—Out-of-Band and Spurious Emissions

CHARACTERISTICS	CONDITION	TYP	MAX	UNIT
Second harmonic ⁽¹⁾	Measured at maximum output power	-14	-2	dBm
Third harmonic ⁽¹⁾		-10	-6	dBm
Fourth harmonics ⁽¹⁾		-19	-11	dBm

(1) Meets FCC and ETSI requirements with external filter shown in [Figure 7-1](#)

5.7.4.2 Bluetooth LE RF Performance

All parameters in this section that are fast-clock dependent are verified using a 26-MHz XTAL under a temperature range from -20°C to 70°C and an RF load of 50 Ω at the BT_RF port.

5.7.4.2.1 BLE Receiver—In-Band Signals

CHARACTERISTIC	CONDITION	MIN	TYP	MAX	BLE SPECIFICATION	UNIT
Operation frequency range		2402		2480		MHz
Channel spacing			2			MHz
Input impedance			50			Ω
Sensitivity, dirty TX on ⁽¹⁾	PER = 30.8%; dirty TX on	-93	-96		≤ -70	dBm
Maximum usable input power	GMSK, PER = 30.8%	-5			≥ -10	dBm
Intermodulation characteristics	Level of interferers (for n = 3, 4, 5)	-36	-30		≥ -50	dBm
C/I performance ⁽²⁾ Image = -1 MHz	GMSK, co-channel		8	12	≤ 21	dB
	GMSK, adjacent ±1 MHz		-5	0	≤ 15	
	GMSK, adjacent +2 MHz		-45	-38	≤ -17	
	GMSK, adjacent -2 MHz		-22	-15	≤ -15	
	GMSK, adjacent ≥ ±3 MHz		-47	-40	≤ -27	
RX mode LO leakage	Fr = (received RF - 0.6 MHz)		-63	-58		dBm

(1) Sensitivity degradation up to 3 dB may occur where the BLE frequency is a harmonic of the fast clock.

(2) Numbers show wanted signal-to-interfering signal ratio. Smaller numbers indicate better C/I performance.

5.7.4.2.2 BLE Receiver—General Blocking

CHARACTERISTICS	CONDITION	MIN	TYP	BLE SPECIFICATION	UNIT
Blocking performance over full range, according to BLE specification ⁽¹⁾	30 to 2000 MHz		-15	≥ -30	dBm
	2000 to 2399 MHz		-15	≥ -35	
	2484 to 3000 MHz		-15	≥ -35	
	3 to 12.75 GHz		-15	≥ -30	

(1) Exceptions are taken out of the total 10 allowed in the BLE specification.

5.7.4.2.3 BLE Transmitter

CHARACTERISTICS	MIN	TYP	MAX	BLE SPECIFICATION	UNIT
Maximum RF output power ⁽¹⁾	10	12 ⁽²⁾		≤ 10	dBm
Power variation over BLE band	-1		1		dB
Adjacent channel power M-N = 2		-45	-39	≤ -20	dBm
Adjacent channel power M-N > 2		-50	-42	≤ -30	

(1) To modify maximum output power, use an HCI VS command.

(2) To achieve the BLE specification of 10-dBm maximum, an insertion loss of > 2 dB is assumed between the RF ball and the antenna. Otherwise, use an HCI VS command to modify the output power.

5.7.4.2.4 BLE Modulation

CHARACTERISTICS	CONDITION		SYM	MIN	TYP	MAX	BLE SPEC.	UNIT
Modulation characteristics	Δf1avg	Mod data = 4 1s, 4 0 s: 1111000011110000...	Δf1 avg	240	250	260	225 to 275	kHz
	Δf2max ≥ limit for at least 99.9% of all Δf2max	Mod data = 1010101...	Δf2 max	185	210		≥ 185	
	Δf2avg, Δf1avg				0.85	0.9		
Absolute carrier frequency drift				-25		25	≤ ±50	kHz
Drift rate						15	≤ 20	kHz/50 ms
Initial carrier frequency tolerance				-75		75	≤ ±100	kHz

5.7.4.2.5 BLE Transceiver, Out-Of-Band and Spurious Emissions

See [Section 5.7.4.1.7, Bluetooth Transmitter, Out-of-Band and Spurious Emissions](#).

6 Detailed Description

6.1 Overview

The CC256x architecture comprises a DRP™ and a point-to-multipoint baseband core. The architecture is based on a single-processor ARM7TDMI[®] core. The device includes several on-chip peripherals to enable easy communication with a host system and the *Bluetooth* BR/EDR/LE core.

6.2 Functional Block Diagram

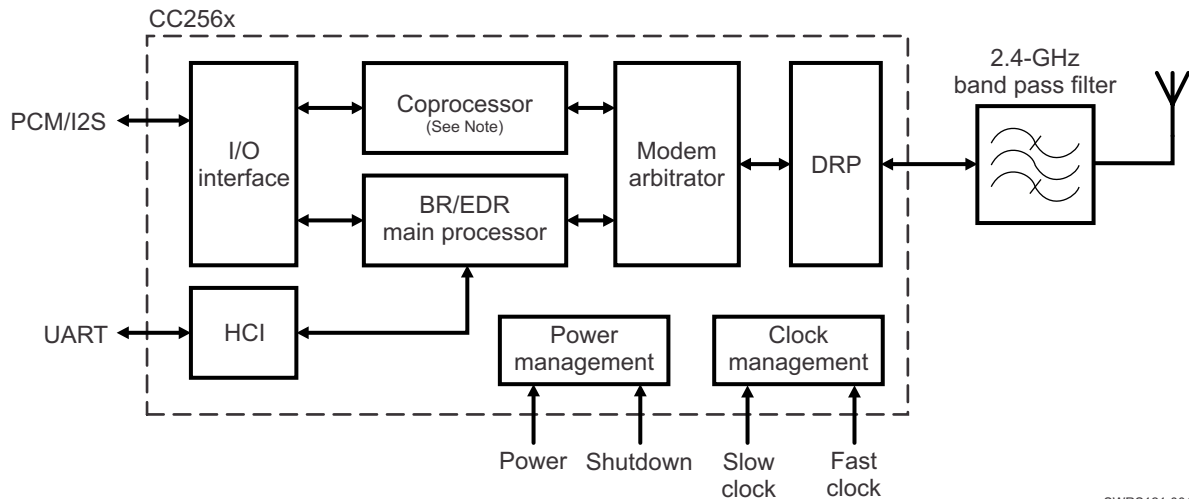

SWRS121-001

Note: The following technologies and assisted modes cannot be used simultaneously with the coprocessor: *Bluetooth* LE, ANT, assisted HFP 1.6 (WBS), and assisted A2DP. One and only one technology or assisted mode can be used at a time.

Figure 6-1. CC256x Functional Block Diagram

6.3 Clock Inputs

This section describes the available clock inputs. For specifications, see [Section 5.7.2, Clock Specifications](#).

6.3.1 Slow Clock

An external source must supply the slow clock and connect to the SLOW_CLK_IN pin (for example, the host or external crystal oscillator). The source must be a digital signal in the range of 0 to 1.8 V. The accuracy of the slow clock frequency must be 32.768 kHz \pm 250 ppm for *Bluetooth* use (as specified in the *Bluetooth* specification). The external slow clock must be stable within 64 slow-clock cycles (2 ms) following the release of nSHUTD.

6.3.2 Fast Clock Using External Clock Source

An external clock source is fed to an internal pulse-shaping cell to provide the fast-clock signal for the device. The device incorporates an internal, automatic clock-scheme detection mechanism that automatically detects the fast-clock scheme used and configures the F_{REF} cell accordingly. This mechanism ensures that the electrical characteristics (loading) of the fast-clock input remain static regardless of the scheme used and eliminates any power-consumption penalty-versus-scheme used.

The frequency variation of the fast-clock source must not exceed \pm 20 ppm (as defined by the *Bluetooth* specification).

The external clock can be AC- or DC-coupled, sine or square wave.

6.3.2.1 External F_{REF} DC-Coupled

Figure 6-2 and Figure 6-3 show the clock configuration when using a square wave, DC-coupled external source for the fast clock input.

NOTE

A shunt capacitor with a range of 10 nF must be added on the oscillator output to reject high harmonics and shape the signal to be close to a sinusoidal waveform.

TI recommends using only a dedicated LDO to feed the oscillator. Do not use the same VIO for the oscillator and the CC256x device.

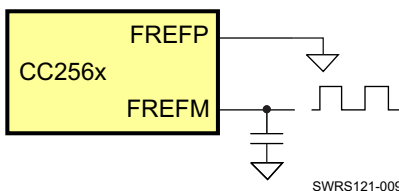

Figure 6-2. Clock Configuration (Square Wave, DC-Coupled)

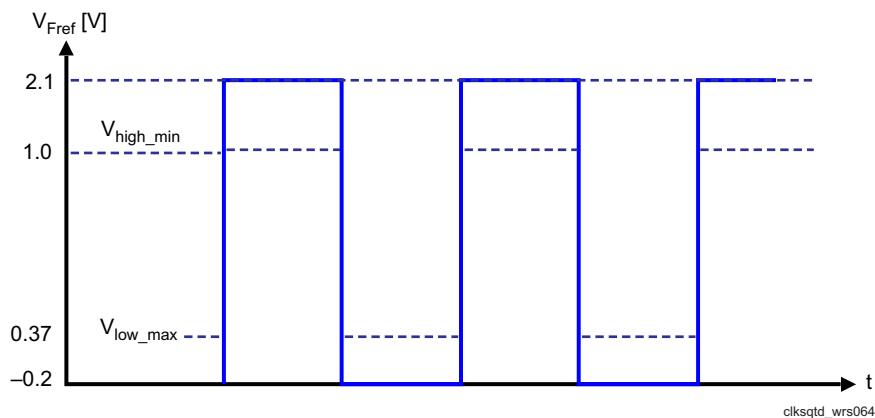

Figure 6-3. External Fast Clock (Square Wave, DC-Coupled)

Figure 6-4 and Figure 6-5 show the clock configuration when using a sine wave, DC-coupled external source for the fast clock input.

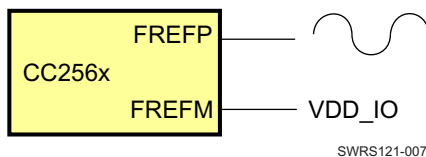

Figure 6-4. Clock Configuration (Sine Wave, DC-Coupled)

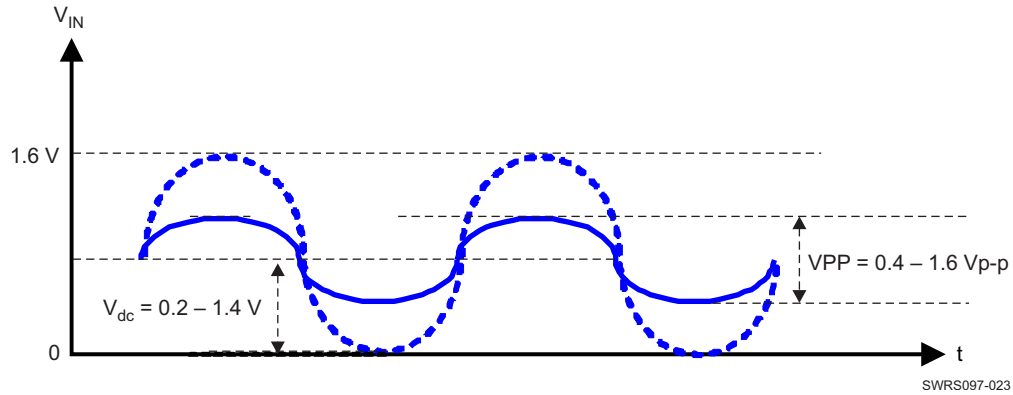

Figure 6-5. External Fast Clock (Sine Wave, DC-Coupled)

6.3.2.2 External F_{REF} Sine Wave, AC-Coupled

Figure 6-6 and Figure 6-7 show the configuration when using a sine wave, AC-coupled external source for the fast-clock input.

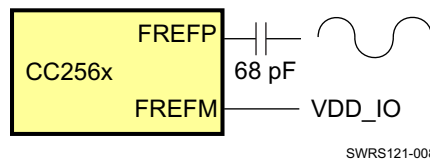

Figure 6-6. Clock Configuration (Sine Wave, AC-Coupled)

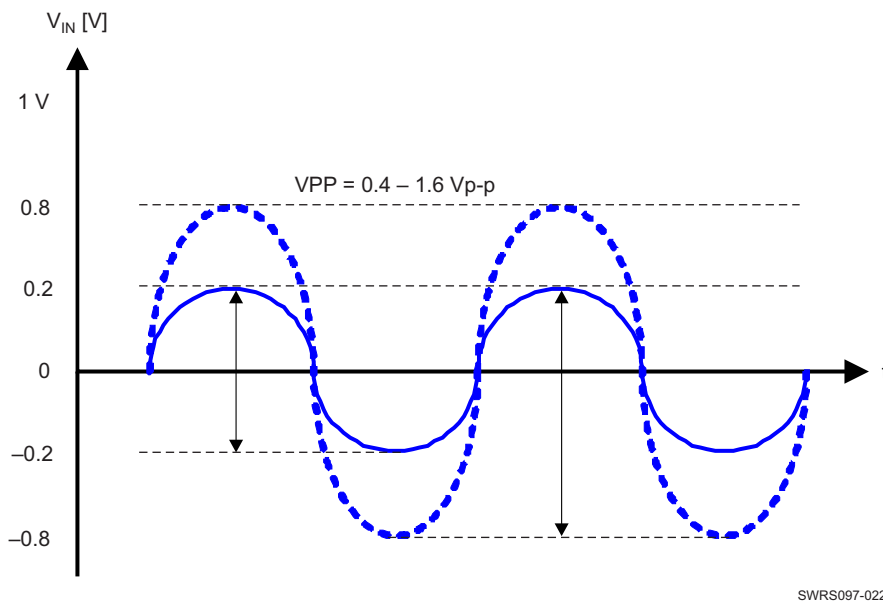

Figure 6-7. External Fast Clock (Sine Wave, AC-Coupled)

In cases where the input amplitude is greater than 1.6 V_{p-p}, the amplitude can be reduced to within limits. Using a small series capacitor forms a voltage divider with the internal input capacitance of approximately 2 pF to provide the required amplitude at the device input.

6.3.2.3 Fast Clock Using External Crystal

The CC256x device incorporates an internal crystal oscillator buffer to support a crystal-based fast-clock scheme. The supported crystal frequencies are 26 and 38.4 MHz.

The frequency accuracy of the fast clock source must not exceed ± 20 ppm (including the accuracy of the capacitors, as specified in the *Bluetooth* specification).

Figure 6-8 shows the recommended fast-clock circuitry.

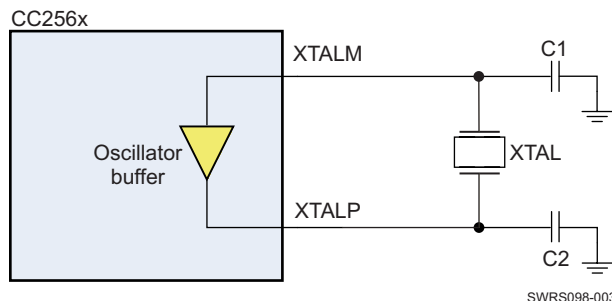

Figure 6-8. Fast-Clock Crystal Circuit

Table 6-1 lists component values for the fast-clock crystal circuit.

Table 6-1. Fast-Clock Crystal Circuit Component Values

FREQ (MHz)	C1 (pF) ⁽¹⁾	C2 (pF) ⁽¹⁾
26	12	12

(1) To achieve the required accuracy, values for C1 and C2 must be taken from the crystal manufacturer's data sheet and layout considerations.

6.4 Functional Blocks

6.4.1 RF

The device is the third generation of TI *Bluetooth* single-chip devices using DRP architecture. Modifications and new features added to the DRP further improve radio performance.

Figure 6-9 shows the DRP block diagram.

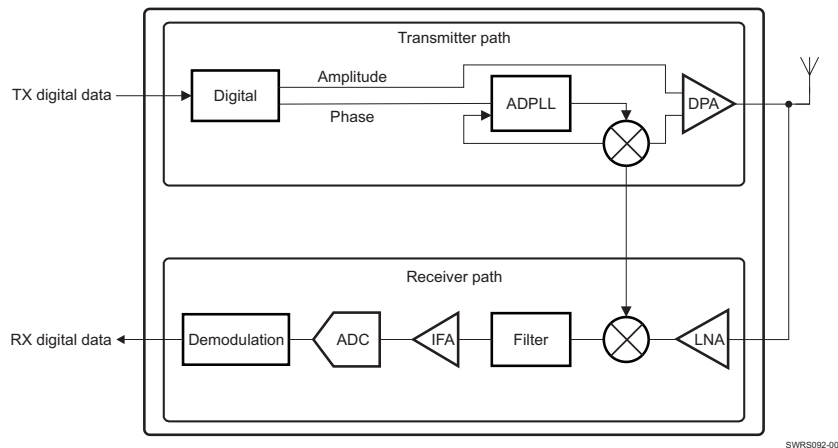

Figure 6-9. DRP Block Diagram

6.4.1.1 Receiver

The receiver uses near-zero-IF architecture to convert the RF signal to baseband data. The signal received from the external antenna is input to a single-ended low-noise amplifier (LNA) and passed to a mixer that downconverts the signal to IF, followed by a filter and amplifier. The signal is then quantized by a sigma-delta analog-to-digital converter (ADC) and further processed to reduce the interference level.

The demodulator digitally downconverts the signal to zero-IF and recovers the data stream using an adaptive-decision mechanism. The demodulator includes EDR processing with:

- State-of-the-art performance
- A maximum-likelihood sequence estimator (MLSE) to improve the performance of basic-rate GFSK sensitivity
- Adaptive equalization to enhance EDR modulation

New features include:

- LNA input range narrowed to increase blocking performance
- Active spur cancellation to increase robustness to spurs

6.4.1.2 Transmitter

The transmitter is an all-digital, sigma-delta phase-locked loop (ADPLL) based with a digitally controlled oscillator (DCO) at 2.4 GHz as the RF frequency clock. The transmitter directly modulates the digital PLL. The power amplifier is also digitally controlled. The transmitter uses the polar-modulation technique. While the phase-modulated control word is fed to the ADPLL, the amplitude-modulated controlled word is fed to the class-E amplifier to generate a *Bluetooth* standard-compliant RF signal.

New features include:

- Improved TX output power
- LMS algorithm to improve the differential error vector magnitude (DEVm)

6.4.2 Host Controller Interface

The CC256x device incorporates one UART module dedicated to the HCI transport layer. The HCI interface transports commands, events, and ACL between the device and the host using HCI data packets.

All members of the CC256x family support the H4 protocol (4-wire UART) with hardware flow control. The CC2560B and CC2564B devices also support the H5 protocol (3-wire UART) with software flow control. The CC256x device automatically detects the protocol when it receives the first command.

The maximum baud rate of the UART module is 4 Mbps; however, the default baud rate after power up is set to 115.2 kbps. The baud rate can thereafter be changed with a VS command. The device responds with a command complete event (still at 115.2 kbps), after which the baud rate change occurs.

The UART module includes the following features:

- Receiver detection of break, idle, framing, FIFO overflow, and parity error conditions
- Transmitter underflow detection
- CTS and RTS hardware flow control (H4 protocol)
- XON and XOFF software flow control (H5 protocol)

Table 6-2 lists the UART module default settings.

Table 6-2. UART Module Default Settings

PARAMETER	VALUE
Bit rate	115.2 kbps
Data length	8 bits

Table 6-2. UART Module Default Settings (continued)

PARAMETER	VALUE
Stop bit	1
Parity	None

6.4.2.1 4-Wire UART Interface—H4 Protocol

The H4 UART Interface includes four signals:

- TX
- RX
- CTS
- RTS

Flow control between the host and the CC256x device is bitwise by hardware.

Figure 6-10 shows the H4 UART interface.

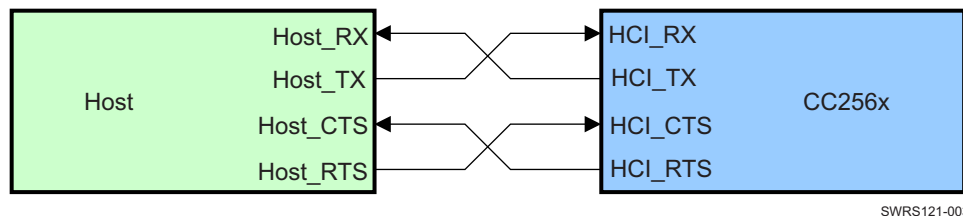
**Figure 6-10. H4 UART Interface**

When the UART RX buffer of the device passes the flow control threshold, it sets the HCI_RTS signal high to stop transmission from the host.

When the HCI_CTS signal is set high, the device stops transmission on the interface. If HCI_CTS is set high while transmitting a byte, the device finishes transmitting the byte and stops the transmission.

The H4 protocol device includes a mechanism that handles the transition between active mode and sleep mode. The protocol occurs through the CTS and RTS UART lines and is known as the enhanced HCI low level (eHCILL) power-management protocol.

For more information on the H4 UART protocol, see *Volume 4 Host Controller Interface, Part A UART Transport Layer of the Bluetooth Core Specifications* (www.bluetooth.org/en-us/specification/adoptedspecifications).

6.4.2.2 3-Wire UART Interface—H5 Protocol (CC2560B and CC2564B Devices)

The H5 UART interface consists of three signals (see Figure 6-11):

- TX
- RX
- GND

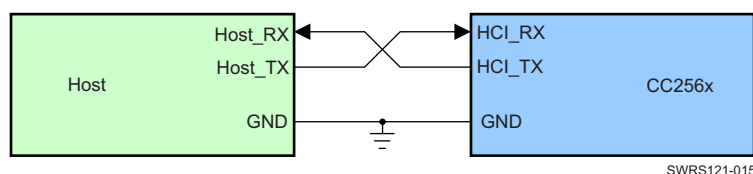
**Figure 6-11. H5 UART Interface**

The H5 protocol supports the following features:

- Software flow control (XON/XOFF)

- Power management using the software messages:
 - WAKEUP
 - WOKEN
 - SLEEP
- CRC data integrity check

For more information on the H5 UART protocol, see *Volume 4 Host Controller Interface, Part D Three-Wire UART Transport Layer of the Bluetooth Core Specifications* (www.bluetooth.org/en-us/specification/adoptedspecifications).

6.4.3 Digital Codec Interface

The codec interface is a fully programmable port to support seamless interfacing with different PCM and I2S codec devices. The interface includes the following features:

- Two voice channels
- Master and slave modes
- All voice coding schemes defined by the *Bluetooth* specification: linear, A-Law, and μ -Law
- Long and short frames
- Different data sizes, order, and positions
- High flexibility to support a variety of codecs
- Bus sharing: Data_Out is in Hi-Z state when the interface is not transmitting voice data.

6.4.3.1 Hardware Interface

The interface includes four signals:

- Clock: configurable direction (input or output)
- Frame_Sync and Word_Sync: configurable direction (input or output)
- Data_In: input
- Data_Out: output or 3-state

The CC256x device can be the master of the interface when generating the Clock and Frame_Sync signals or the slave when receiving these two signals.

For slave mode, clock input frequencies of up to 15 MHz are supported. At clock rates above 12 MHz, the maximum data burst size is 32 bits.

For master mode, the device can generate any clock frequency between 64 kHz and 4.096 MHz.

6.4.3.2 I2S

When the codec interface is configured to support the I2S protocol, these settings are recommended:

- Bidirectional, full-duplex interface
- Two time slots per frame: time slot-0 for the left channel audio data; and time slot-1 for the right channel audio data
- Each time slot is configurable up to 40 serial clock cycles long, and the frame is configurable up to 80 serial clock cycles long.

6.4.3.3 Data Format

The data format is fully configurable:

- The data length can be from 8 to 320 bits in 1-bit increments when working with 2 channels, or up to 640 bits when working with 1 channel. The data length can be set independently for each channel.
- The data position within a frame is also configurable within 1 clock (bit) resolution and can be set independently (relative to the edge of the Frame_Sync signal) for each channel.

- The Data_In and Data_Out bit order can be configured independently. For example; Data_In can start with the most significant bit (MSB); Data_Out can start with the least significant bit (LSB). Each channel is separately configurable. The inverse bit order (that is, LSB first) is supported only for sample sizes up to 24 bits.
- Data_In and Data_Out are not required to be the same length.
- The Data_Out line is configured to Hi-Z output between data words. Data_Out can also be set for permanent Hi-Z, regardless of the data output. This configuration allows the device to be a bus slave in a multislave PCM environment. At power up, Data_Out is configured as Hi-Z.

6.4.3.4 Frame Idle Period

The codec interface handles frame idle periods, in which the clock pauses and becomes 0 at the end of the frame, after all data are transferred.

The device supports frame idle periods both as master and slave of the codec bus.

When the device is the master of the interface, the frame idle period is configurable. There are two configurable parameters:

- Clk_Idle_Start: indicates the number of clock cycles from the beginning of the frame to the beginning of the idle period. After Clk_Idle_Start clock cycles, the clock becomes 0.
- Clk_Idle_End: indicates the time from the beginning of the frame to the end of the idle period. The time is given in multiples of clock periods.

The delta between Clk_Idle_Start and Clk_Idle_End is the clock idle period.

For example, for clock rate = 1 MHz, frame sync period = 10 kHz, Clk_Idle_Start = 60, Clk_Idle_End = 90.

Between both Frame_Sync signals there are 70 clock cycles (instead of 100). The clock idle period starts 60 clock cycles after the beginning of the frame and lasts $90 - 60 = 30$ clock cycles. Thus, the idle period ends $100 - 90 = 10$ clock cycles before the end of the frame. The data transmission must end before the beginning of the idle period.

Figure 6-12 shows the frame idle timing.

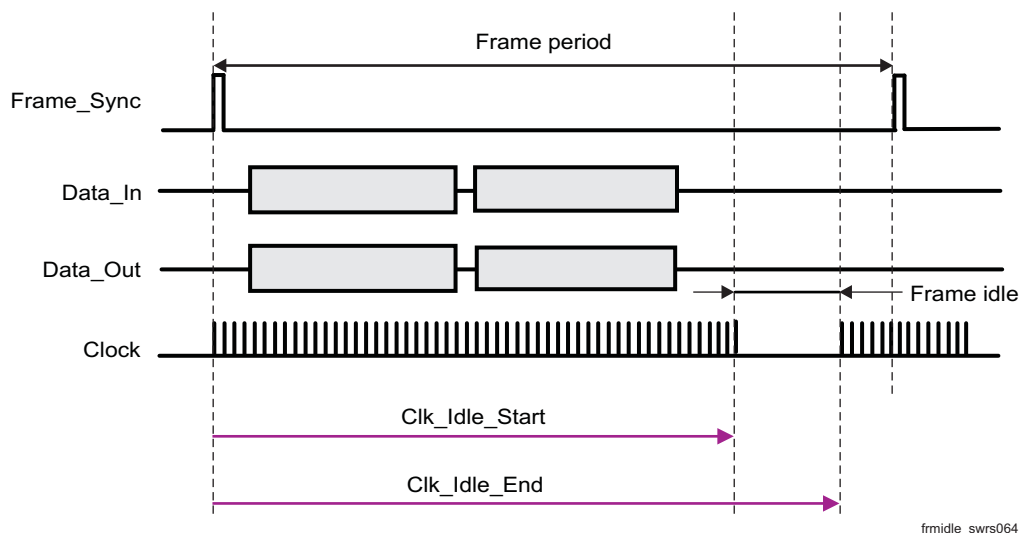

Figure 6-12. Frame Idle Period

6.4.3.5 Clock-Edge Operation

The codec interface of the device can work on the rising or the falling edge of the clock and can sample the Frame_Sync signal and the data at inversed polarity.

Figure 6-13 shows the operation of a falling-edge-clock type of codec. The codec is the master of the bus. The Frame_Sync signal is updated (by the codec) on the falling edge of the clock and is therefore sampled (by the device) on the next rising clock. The data from the codec is sampled (by the device) on the falling edge of the clock.

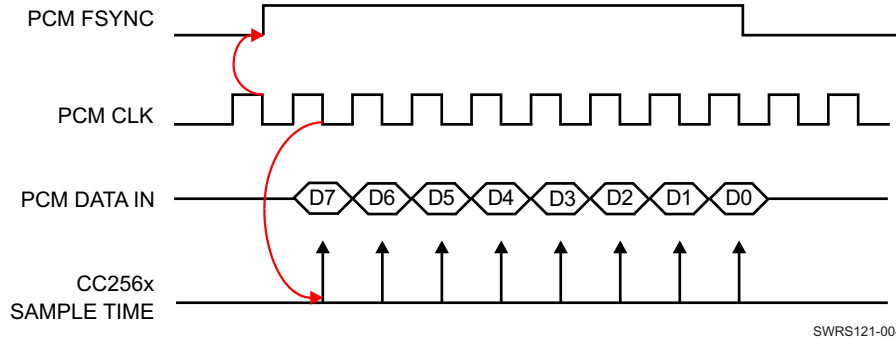

Figure 6-13. Negative Clock Edge Operation

6.4.3.6 Two-Channel Bus Example

Figure 6-14 shows a 2-channel bus in which the two channels have different word sizes and arbitrary positions in the bus frame. (FT stands for frame timer.)

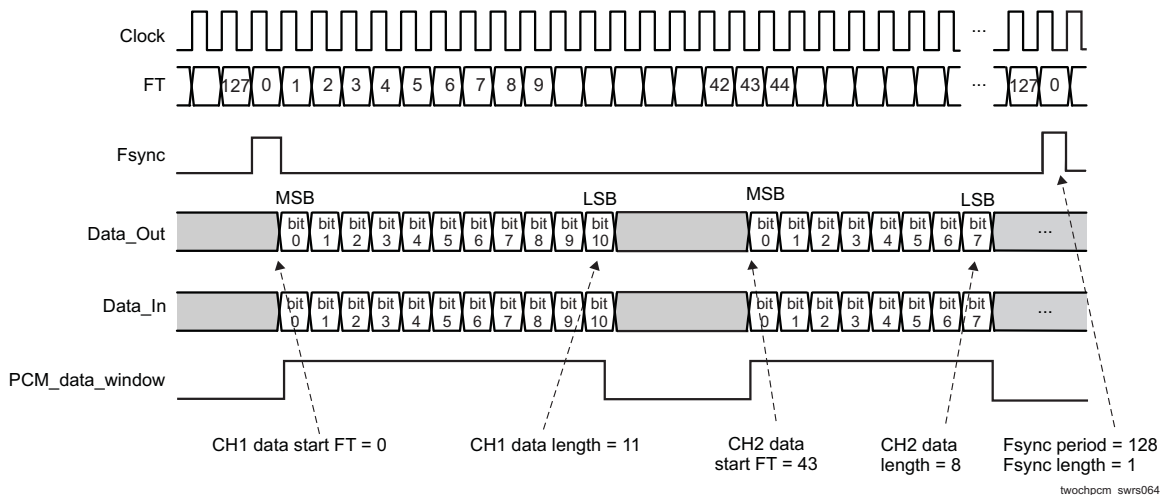

Figure 6-14. 2-Channel Bus Timing

6.4.3.7 Improved Algorithm For Lost Packets

The device features an improved algorithm to improve voice quality when received voice data packets are lost. There are two options:

- Repeat the last sample: possible only for sample sizes up to 24 bits. For sample sizes larger than 24 bits, the last byte is repeated.
- Repeat a configurable sample of 8 to 24 bits (depending on the real sample size) to simulate silence (or anything else) in the bus. The configured sample is written in a specific register for each channel.

The choice between those two options is configurable separately for each channel.

6.4.3.8 Bluetooth and Codec Clock Mismatch Handling

In *Bluetooth* RX, the device receives RF voice packets and writes them to the codec interface. If the device receives data faster than the codec interface output allows, an overflow occurs. In this case, the *Bluetooth* RX has two possible modes of behavior:

- Allow overflow: if overflow is allowed, the *Bluetooth* RX continues receiving data and overwrites any data not yet sent to the codec.
- Do not allow overflow: if overflow is not allowed, RF voice packets received when the buffer is full are discarded.

6.4.4 Assisted Modes (CC2560B and CC2564B Devices)

The CC256x device contains an embedded coprocessor that can be used for multiple purposes (see [Figure 1-1](#)). The CC2564 and CC2564B devices use the coprocessor to perform the LE or ANT functionality. The CC256x device uses the coprocessor to execute the assisted HFP 1.6 (WBS) or assisted A2DP functions. Only one of these functions can be executed at a time because they all use the same resources (that is, the coprocessor; see [Table 3-1](#) for the modes of operation supported by each device).

This section describes the assisted HFP 1.6 (WBS) and assisted A2DP modes of operation in the CC256x device. These modes of operation minimize host processing and power by taking advantage of the device coprocessor to perform the voice and audio SBC processing required in HFP 1.6 (WBS) and A2DP profiles. This section also compares the architecture of the assisted modes with the common implementation of the HFP 1.6 and A2DP profiles.

The assisted HFP 1.6 (WBS) and assisted A2DP modes of operation comply fully with the HFP 1.6 and A2DP *Bluetooth* specifications. For more information on these profiles, see the corresponding *Bluetooth* Profile Specification (www.bluetooth.org/en-us/specification/adopted-specifications).

6.4.4.1 Assisted HFP 1.6 (WBS)

The *HFP 1.6 Profile Specification* adds the requirement for WBS support. The WBS feature allows twice the voice quality versus legacy voice coding schemes at the same air bandwidth (64 kbps). This feature is achieved using a voice sampling rate of 16 kHz, a modified subband coding (mSBC) scheme, and a packet loss concealment (PLC) algorithm. The mSBC scheme is a modified version of the mandatory audio coding scheme used in the A2DP profile with the parameters listed in [Table 6-3](#).

Table 6-3. mSBC Parameters

PARAMETER	VALUE
Channel mode	Mono
Sampling rate	16 kHz
Allocation method	Loudness
Subbands	8
Block length	15
Bitpool	26

The assisted HFP 1.6 mode of operation implements this WBS feature on the embedded CC256x coprocessor. That is, the mSBC voice coding scheme and the PLC algorithm are executed in the CC256x coprocessor rather than in the host, thus minimizing host processing and power. One WBS connection at a time is supported and WBS and NBS connections cannot be used simultaneously in this mode of operation. [Figure 6-15](#) shows the architecture comparison between the common implementation of the HFP 1.6 profile and the assisted HFP 1.6 solution.

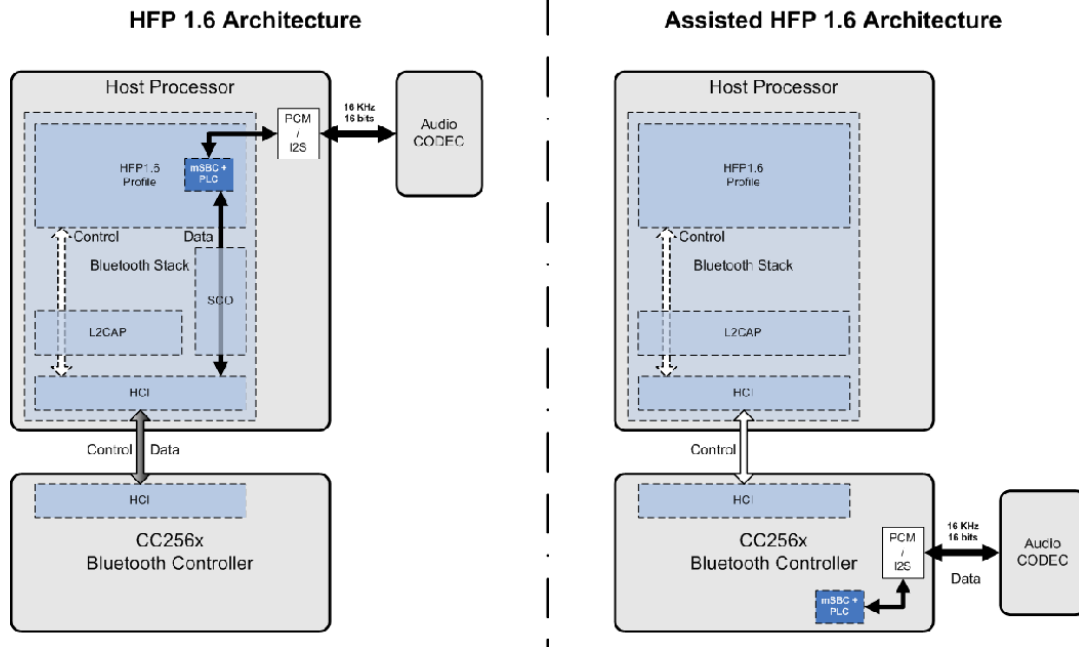

Figure 6-15. HFP 1.6 Architecture Versus Assisted HFP 1.6 Architecture

For detailed information on the HFP 1.6 profile, see the *Hands-Free Profile 1.6 Specification* (www.bluetooth.org/en-us/specification/adopted-specifications).

6.4.4.2 Assisted A2DP

The advanced audio distribution profile (A2DP) enables wireless transmission of high-quality mono or stereo audio between two devices. A2DP defines two roles:

- A2DP source is the transmitter of the audio stream.
- A2DP sink is the receiver of the audio stream.

A typical use case streams music from a tablet, phone, or PC (the A2DP source) to headphones or speakers (the A2DP sink). This section describes the architecture of these roles and compares them with the corresponding assisted-A2DP architecture. To use the air bandwidth efficiently, the audio data must be compressed in a proper format. The A2DP mandates support of the SBC scheme. Other audio coding algorithms can be used; however, both *Bluetooth* devices must support the same coding scheme. SBC is the only coding scheme spread out in all A2DP *Bluetooth* devices, and thus the only coding scheme supported in the assisted A2DP modes. Table 6-4 lists the recommended parameters for the SBC scheme in the assisted A2DP modes.

Table 6-4. Recommended Parameters for the SBC Scheme in Assisted A2DP Modes

SBC ENCODER SETTINGS ⁽¹⁾	MID QUALITY				HIGH QUALITY			
	MONO		JOINT STEREO		MONO		JOINT STEREO	
Sampling frequency (kHz)	44.1	48	44.1	48	44.1	48	44.1	48
Bitpool value	19	18	35	33	31	29	53	51
Resulting frame length (bytes)	46	44	83	79	70	66	119	115
Resulting bit rate (Kbps)	127	132	229	237	193	198	328	345

(1) Other settings: Block length = 16; allocation method = loudness; subbands = 8.

The SBC scheme supports a wide variety of configurations to adjust the audio quality. [Table 6-5](#) through [Table 6-12](#) list the supported SBC capabilities in the assisted A2DP modes.

Table 6-5. Channel Modes

CHANNEL MODE	STATUS
Mono	Supported
Dual channel	Supported
Stereo	Supported
Joint stereo	Supported

Table 6-6. Sampling Frequency

SAMPLING FREQUENCY (kHz)	STATUS
16	Supported
44.1	Supported
48	Supported

Table 6-7. Block Length

BLOCK LENGTH	STATUS
4	Supported
8	Supported
12	Supported
16	Supported

Table 6-8. Subbands

SUBBANDS	STATUS
4	Supported
8	Supported

Table 6-9. Allocation Method

ALLOCATION METHOD	STATUS
SNR	Supported
Loudness	Supported

Table 6-10. Bitpool Values

BITPOOL RANGE	STATUS
Assisted A2DP sink: 2–54	Supported
Assisted A2DP source: 2–57	Supported

Table 6-11. L2CAP MTU Size

L2CAP MTU SIZE (BYTES)	STATUS
Assisted A2DP sink: 260–800	Supported
Assisted A2DP source: 260–1021	Supported

Table 6-12. Miscellaneous Parameters

ITEM	VALUE	STATUS
A2DP content protection	Protected	Not supported
AVDTP service	Basic type	Supported

Table 6-12. Miscellaneous Parameters (continued)

ITEM	VALUE	STATUS
L2CAP mode	Basic mode	Supported
L2CAP flush	Nonflushable	Supported

For detailed information on the A2DP profile, see the A2DP Profile Specification at [Adopted Bluetooth Core Specifications](#).

6.4.4.2.1 Assisted A2DP Sink

The A2DP sink role is the receiver of the audio stream in an A2DP *Bluetooth* connection. In this role, the A2DP layer and its underlying layers are responsible for link management and data decoding. To handle these tasks, two logic transports are defined:

- Control and signaling logic transport
- Data packet logic transport

The assisted A2DP takes advantage of this modularity to handle the data packet logic transport in the CC256x device by implementing a light L2CAP layer (L-L2CAP) and light AVDTP layer (L-AVDTP) to defragment the packets. Then the assisted A2DP performs the SBC decoding on-chip to deliver raw audio data through the CC256x PCM–I2S interface. [Figure 6-16](#) shows the comparison between a common A2DP sink architecture and the assisted A2DP sink architecture.

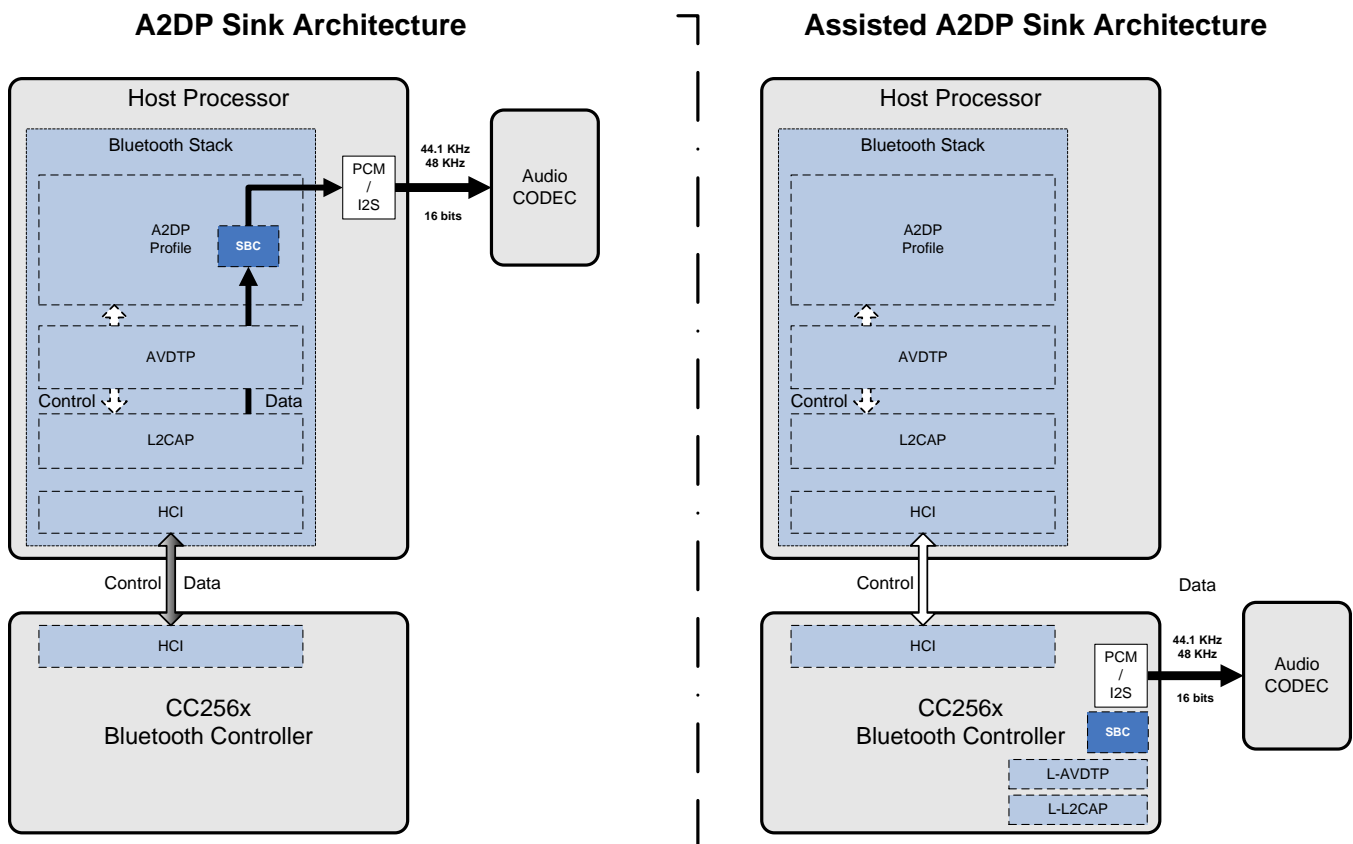

Figure 6-16. A2DP Sink Architecture Versus Assisted A2DP Sink Architecture

For more information on the A2DP sink role, see the *A2DP Profile Specification* at [Adopted Bluetooth Core Specifications](#).

6.4.4.2.2 Assisted A2DP Source

The role of the A2DP source is to transmit the audio stream in an A2DP *Bluetooth* connection. In this role, the A2DP layer and its underlying layers are responsible for link management and data encoding. To handle these tasks, two logic transports are defined:

- Control and signaling logic transport
- Data packet logic transport

The assisted A2DP takes advantage of this modularity to handle the data packet logic transport in the CC256x device. First, the assisted A2DP encodes the raw data from the CC256x PCM–I2S interface using an on-chip SBC encoder. The assisted A2DP then implements an L-L2CAP layer and an L-AVDTP layer to fragment and packetize the encoded audio data. [Figure 6-17](#) shows the comparison between a common A2DP source architecture and the assisted A2DP source architecture.

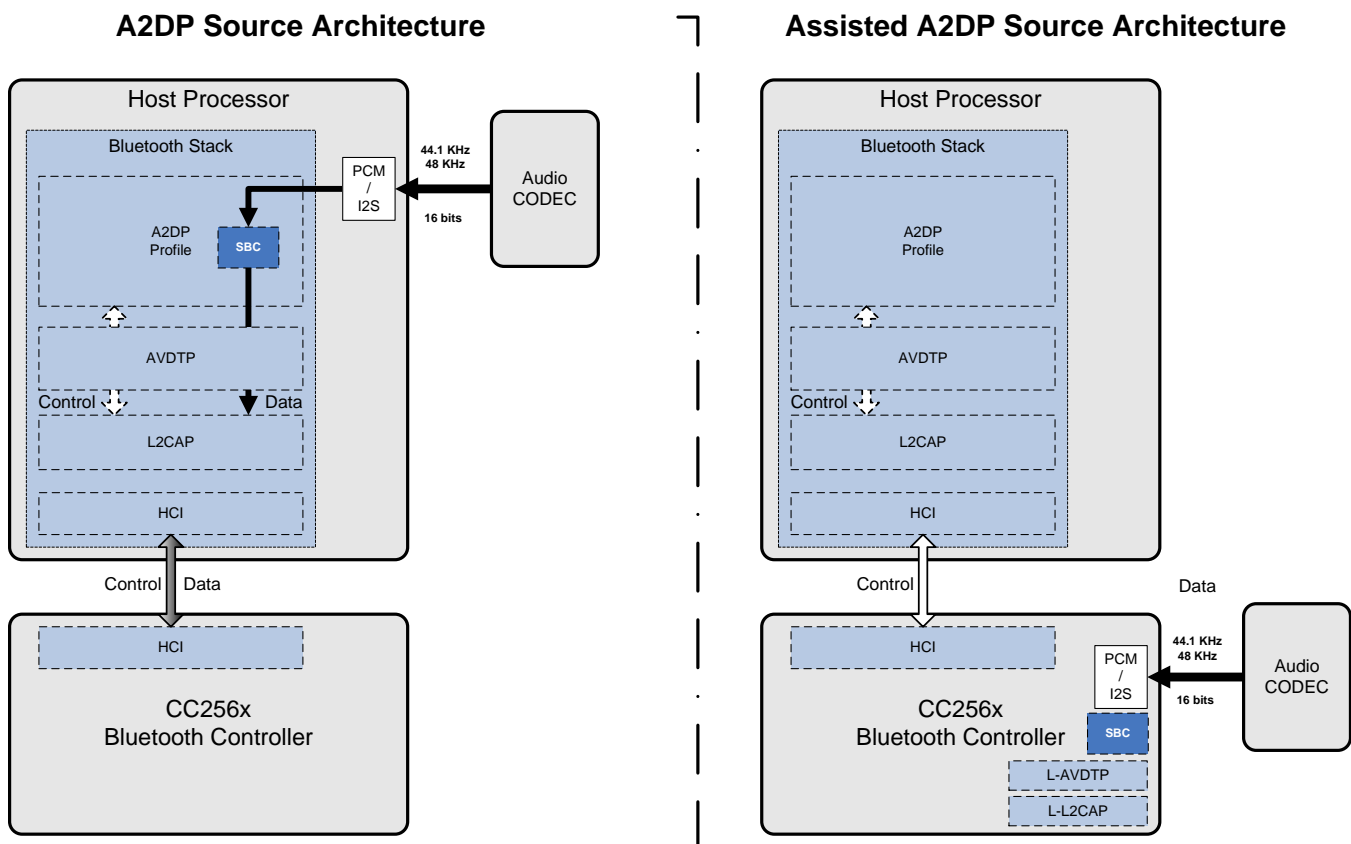

Figure 6-17. A2DP Source Architecture Versus Assisted A2DP Source Architecture

For more information on the A2DP source role, see the A2DP Profile Specification at [Adopted Bluetooth Core Specifications](#).

6.5 Bluetooth BR/EDR Features

The CC2564B/CC2560B devices fully comply with the *Bluetooth* 4.0 specification up to the HCI level. The CC2560B/CC2564B devices are compliant with the *Bluetooth* 4.1 specification up to the HCI layer (for family members and technology supported, see [Table 3-1](#)):

- Up to seven active devices
- Scatternet: Up to 3 piconets simultaneously, 1 as master and 2 as slaves
- Up to two synchronous connection oriented (SCO) links on the same piconet

- Very fast AFH algorithm for asynchronous connection-oriented link (ACL) and extended SCO (eSCO) link
- Supports typical 12-dBm TX power without an external power amplifier (PA), thus improving *Bluetooth* link robustness
- Digital radio processor (DRP™) single-ended 50-Ω I/O for easy RF interfacing
- Internal temperature detection and compensation to ensure minimal variation in RF performance over temperature
- Includes a 128-bit hardware encryption accelerator as defined by the *Bluetooth* specifications
- Flexible pulse-code modulation (PCM) and inter-IC sound (I2S) digital codec interface:
 - Full flexibility of data format (linear, A-Law, μ-Law)
 - Data width
 - Data order
 - Sampling
 - Slot positioning
 - Master and slave modes
 - High clock rates up to 15 MHz for slave mode (or 4.096 MHz for master mode)
- Support for all voice air-coding
 - CVSD
 - A-Law
 - μ-Law
 - Transparent (uncoded)
- The CC2560B and CC2564B devices provide an assisted mode for the HFP 1.6 (wide-band speech [WBS]) profile or A2DP profile to reduce host processing and power.

6.6 *Bluetooth* LE Description

The CC2564B device fully complies with the *Bluetooth* 4.0 specification up to the HCI level. The CC2564B device is *Bluetooth* 4.1 specification compliant up to the HCI layer (for the family members and technology supported, see [Table 3-1](#)):

- Solution optimized for proximity and sports use cases
- Supports up to 10 (CC2564B) simultaneous connections
- Multiple sniff instances that are tightly coupled to achieve minimum power consumption
- Independent buffering for LE, allowing large numbers of multiple connections without affecting BR/EDR performance
- Built-in coexistence and prioritization handling

NOTE

ANT and the assisted modes (HFP 1.6 and A2DP) are not available when BLE is enabled.

6.7 Bluetooth Transport Layers

Figure 6-18 shows the *Bluetooth* transport layers.

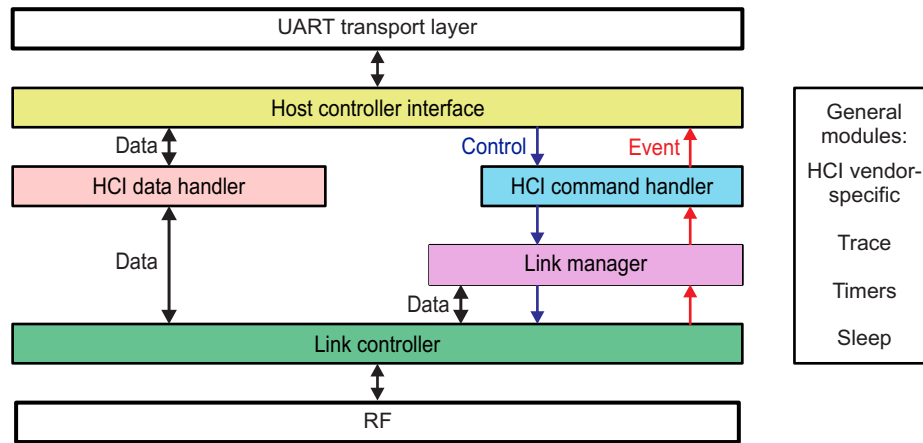

SWRS121-016

Figure 6-18. Bluetooth Transport Layers

6.8 Changes from CC2560A and CC2564 to CC2560B and CC2564B Devices

The CC2560B and CC2564B devices include the following changes from the CC2560A and CC2564 devices:

- From a hardware perspective, both devices are pin compatible. From a software perspective, each device requires a different service pack. When operating with the two devices using the supported *Bluetooth* stack, the devices are integrated seamlessly and use remains identical for each device.
- Assisted mode for the HFP 1.6 (WBS) profile or the A2DP profile to enable more advanced features without using host processing or power
- Support for the H5 protocol in the UART transport layer using 2-wire UART
- Enable 10 *Bluetooth* LE connections

7 Applications, Implementation, and Layout

Information in the following Applications section is not part of the TI component specification, and TI does not warrant its accuracy or completeness. TI's customers are responsible for determining suitability of components for their purposes. Customers should validate and test their design implementation to confirm system functionality.

7.1 Reference Design Schematics and BOM for Power and Radio Connections

Figure 7-1 shows the reference schematics for the CC256x device. Consult TI for complete schematics and PCB layout guidelines.

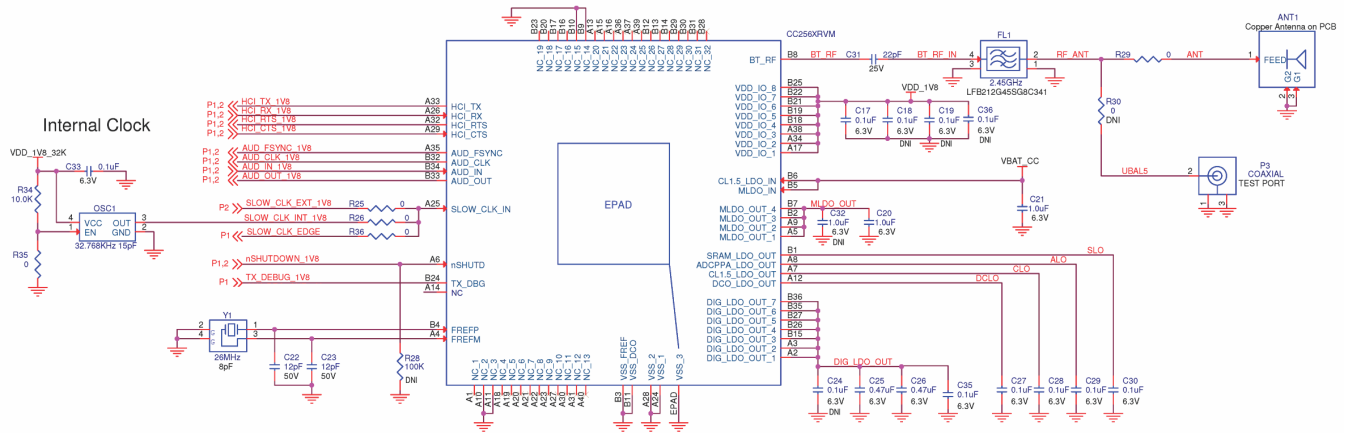

Figure 7-1. Reference Schematics

Table 7-1 lists the BOM for the CC256x device.

Table 7-1. Bill of Materials

QTY	REF. DES.	VALUE	DESCRIPTION	MFR	MFR PART NUMBER	ALT. PART	NOTES
1	ANT1	NA	ANT_IIFA_CC2420_32mil_MIR	NA	IIFA_CC2420	Chip antenna	Copper antenna on PCB
6	Capacitor	0.1 μ F	Capacitor, Ceramic; 0.1- μ F 6.3-V 10% X7R 0402	Kemet	C0402C104K9RACTU		
2	Capacitor	1.0 μ F	Capacitor, Ceramic; 1.0- μ F 6.3-V 10% X5R 0402	Taiyo Yuden	JMK105BJ105KV-F		
2	Capacitor	12 pF	Capacitor, Ceramic; 12 pF 6.3-V X5R 10% 0402	Murata Electronics	GRM1555C1H120JZ01D		
2	Capacitor	0.47 μ F	Capacitor, Ceramic; 47- μ F 6.3-V X5R \pm 10% 0402	Taiyo Yuden	JMK105BJ474KV-F		
1	FL1	2.45 GHz	Filter, Ceramic Bandpass, 2.45-GHz SMD	Murata Electronics	LFB212G45SG8C341	DEA162450 BT_1260B3 (TDK)	Place brown marking up
1	OSC1	32.768 kHz 15 pF	Oscillator; 32.768-kHz 15-pF 1.5-V 3.3-V SMD	Abracorn Corporation	ASH7K-32.768KHZ-T		Optional
1	U5	CC2560BRVM, CC2564BRVM	CC256x Dual-Mode Bluetooth Controller	Texas Instruments	CC256xRVM		
1	Y1	26 MHz	Crystal, 26 MHz	NDK	NX2016SA	TZ1325D (Tai-Saw TST)	
1	C31	22 pF	Capacitor, Ceramic; 22-PF 25-V 5% NP0 0201	Murata Electronics North America	GRM0335C1E220JD01D (EXS00A-CS06025)		

8 Device and Documentation Support

8.1 Device Support

8.1.1 Development Support

The following products support development of the CC256x device:

- [TI dual-mode Bluetooth stack on MSP430 MCUs](#)
- [TI dual-mode Bluetooth stack on TM4C MCUs](#)
- [TI dual-mode Bluetooth stack on STM32F4 MCUs](#)
- [CC256x Bluetooth Hardware Evaluation Tool](#)

For a complete listing of development-support tools, see the TI [CC256x wiki](#). For information on pricing and availability, contact the nearest TI field sales office or authorized distributor.

8.1.2 Device Nomenclature

To designate the stages in the product development cycle, TI assigns prefixes to the part numbers. These prefixes represent evolutionary stages of product development from engineering prototypes through fully qualified production devices.

- X Experimental, preproduction, sample or prototype device. Device may not meet all product qualification conditions and may not fully comply with TI specifications. Experimental/Prototype devices are shipped against the following disclaimer: "This product is still in development and is intended for internal evaluation purposes." Notwithstanding any provision to the contrary, TI makes no warranty expressed, implied, or statutory, including any implied warranty of merchantability of fitness for a specific purpose, of this device.
- null Device is qualified and released to production. TI's standard warranty applies to production devices.

8.2 Documentation Support

The following documents support the CC256x device:

- [Dual-Mode Bluetooth CC2564 Evaluation Board User Guide \(SWRU450\)](#)
- [Dual-Mode Bluetooth CC2564 Evaluation Board Quick Start Guide \(SWRU441\)](#)
- [CC256XQFN PCB Guidelines \(SWRU420\)](#)
- [QFN/SON PCB Attachment Application Report \(SLUA271\)](#)
- [CC256x Hardware Design Checklist \(SWRR124\)](#)
- [DN035 Antenna Quick Guide \(SWRA351\)](#)
- [AN058 Antenna Selection Guide \(SWRA161\)](#)
- [Using TI Technology to Simplify Bluetooth Pairing Via NFC \(SLAA512\)](#)
- [Surface Mount Assembly of Amkor's Dual Row MicroLeadFrame \(MLF\) Packages](#)

8.3 Related Links

[Table 8-1](#) lists quick access links. Categories include technical documents, support and community resources, tools and software, and quick access to sample or buy.

Table 8-1. Related Links

PARTS	PRODUCT FOLDER	SAMPLE & BUY	TECHNICAL DOCUMENTS	TOOLS & SOFTWARE	SUPPORT & COMMUNITY
CC2560A (NRND) ⁽¹⁾	Click here	Click here	Click here	Click here	Click here
CC2560B	Click here	Click here	Click here	Click here	Click here
CC2564 (NRND) ⁽¹⁾	Click here	Click here	Click here	Click here	Click here
CC2564B	Click here	Click here	Click here	Click here	Click here

(1) NRND = Not recommended for new designs

8.4 Community Resources

The following links connect to TI community resources. Linked contents are provided "AS IS" by the respective contributors. They do not constitute TI specifications and do not necessarily reflect TI's views; see TI's [Terms of Use](#).

TI E2E™ Online Community *TI's Engineer-to-Engineer (E2E) Community*. Created to foster collaboration among engineers. At e2e.ti.com, you can ask questions, share knowledge, explore ideas and help solve problems with fellow engineers.

TI Embedded Processors Wiki *Texas Instruments Embedded Processors Wiki*. Established to help developers get started with Embedded Processors from Texas Instruments and to foster innovation and growth of general knowledge about the hardware and software surrounding these devices.

8.5 Trademarks

MSP430, DRP, E2E are trademarks of Texas Instruments.
Cortex, ARM7TDMIE are registered trademarks of ARM Limited.
ARM is a registered trademark of ARM Physical IP, Inc.
iPod is a registered trademark of Apple, Inc.
Dual-Mode Bluetooth are registered trademarks of Bluetooth SIG, Inc.
All other trademarks are the property of their respective owners.

8.6 Electrostatic Discharge Caution



This integrated circuit can be damaged by ESD. Texas Instruments recommends that all integrated circuits be handled with appropriate precautions. Failure to observe proper handling and installation procedures can cause damage.

ESD damage can range from subtle performance degradation to complete device failure. Precision integrated circuits may be more susceptible to damage because very small parametric changes could cause the device not to meet its published specifications.

8.7 Glossary

TI Glossary This glossary lists and explains terms, acronyms, and definitions.

RVM (S-PVQFN-N76)

PLASTIC QUAD FLATPACK NO-LEAD

THERMAL INFORMATION

This package incorporates an exposed thermal pad that is designed to be attached directly to an external heatsink. The thermal pad must be soldered directly to the printed circuit board (PCB). After soldering, the PCB can be used as a heatsink. In addition, through the use of thermal vias, the thermal pad can be attached directly to the appropriate copper plane shown in the electrical schematic for the device, or alternatively, can be attached to a special heatsink structure designed into the PCB. This design optimizes the heat transfer from the integrated circuit (IC).

For information on the Quad Flatpack No-Lead (QFN) package and its advantages, refer to Application Report, QFN/SON PCB Attachment, Texas Instruments Literature No. SLUA271. This document is available at www.ti.com.

The exposed thermal pad dimensions for this package are shown in the following illustration.

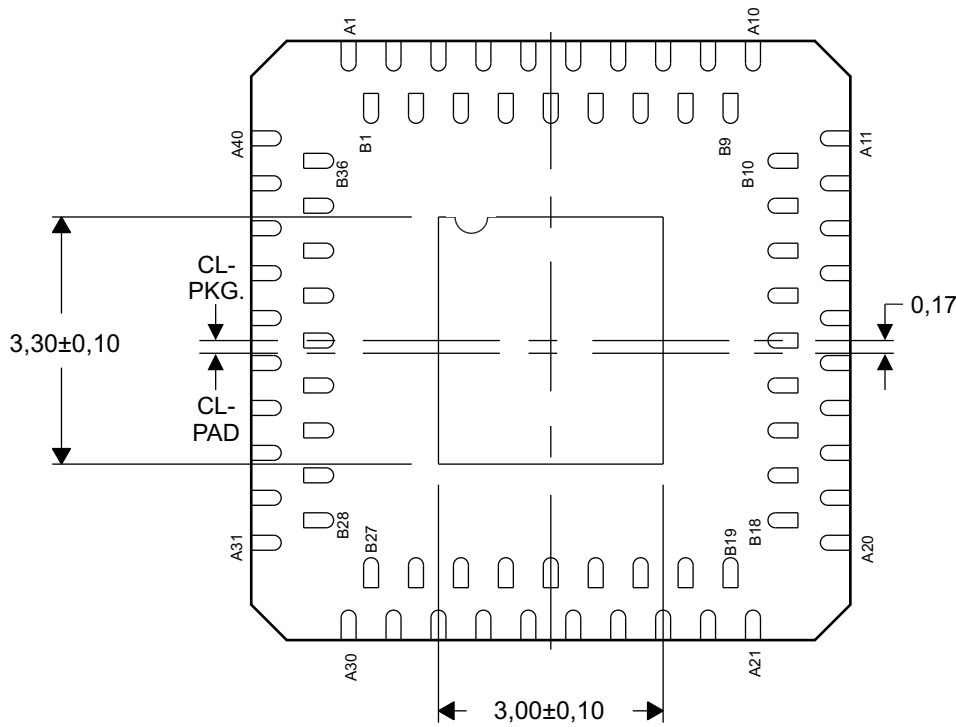

Bottom View

Exposed Thermal Pad Dimensions

4212066/B 12/11

NOTE: All linear dimensions are in millimeters

SWRS115-018

9.2 Packaging and Ordering

9.2.1 Package and Ordering Information

The mrQFN packaging is 76 pins and a 0.6-mm pitch.

For detailed information, see [Section 9.1](#), *mrQFN Mechanical Data*.

[Table 9-1](#) lists the package and order information for the device family members.

Table 9-1. Package and Order Information

DEVICE	PACKAGE SUFFIX	PIECES/REEL
CC2560ARVMT (NRND) ⁽¹⁾	RVM	250
CC2560ARVMR (NRND) ⁽¹⁾	RVM	2500
CC2564RVMT (NRND) ⁽¹⁾	RVM	250
CC2564RVMR (NRND) ⁽¹⁾	RVM	2500
CC2560BRVMT	RVM	250
CC2560BRVMR	RVM	2500
CC2564BRVMT	RVM	250
CC2564BRVMR	RVM	2500

(1) NRND = Not recommended for new designs

[Figure 9-1](#) shows the markings for the CC256x family.

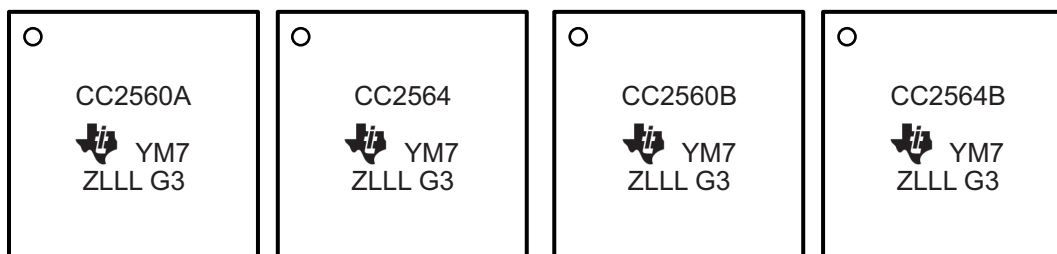

- Y = Last digit of the year
- M = Month in hex number, 1-C for Jan-Dec
- 7 = Primary site code for ANM
- Z = Secondary site code for ANM
- LLL = Assembly lot code
- = Pin 1 indicator

SWRS121-010

Figure 9-1. Chip Markings

9.2.2 Empty Tape Portion

Figure 9-2 shows the empty portion of the carrier tape.

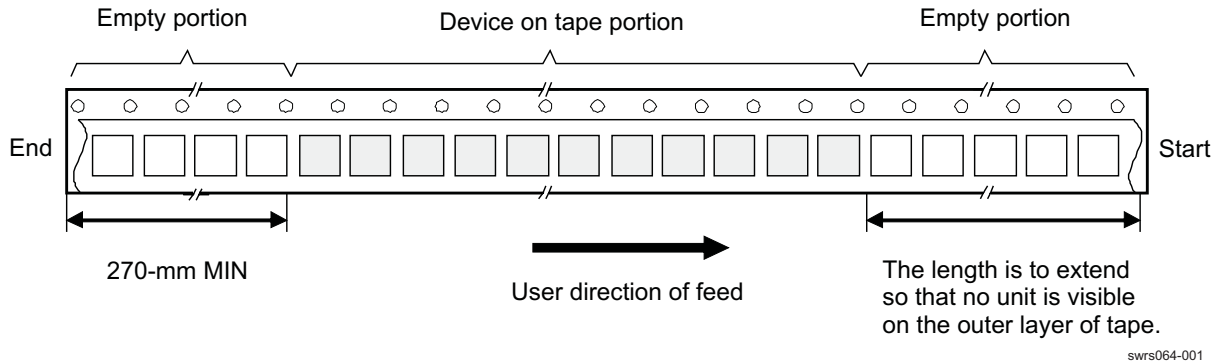

Figure 9-2. Carrier Tape and Pockets

9.2.3 Device Quantity and Direction

When pulling out the tape, the A1 corner is on the left side (see Figure 9-3).

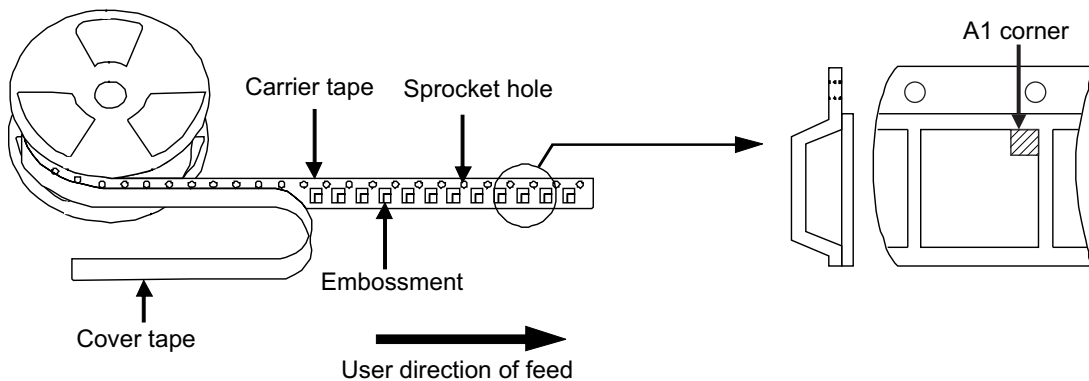

Figure 9-3. Direction of Device

9.2.4 Insertion of Device

Figure 9-4 shows the insertion of the device.

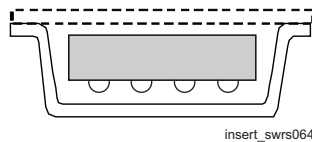

Figure 9-4. Insertion of Device

9.2.5 Tape Specification

The dimensions of the tape are:

- Tape width: 16 mm
- Cover tape: The cover tape does not cover the index hole and does not shift to outside from the carrier tape.
- Tape structure: The carrier tape is made of plastic. The device is put in the embossed area of the carrier tape and covered by the cover tape, which is made of plastic.

- ESD countermeasure: The plastic material used in the carrier tape and the cover tape is static dissipative.

9.2.6 Reel Specification

Figure 9-5 shows the reel specifications:

- 330-mm reel, 16-mm width tape
- Reel material: Polystyrene (static dissipative/antistatic)

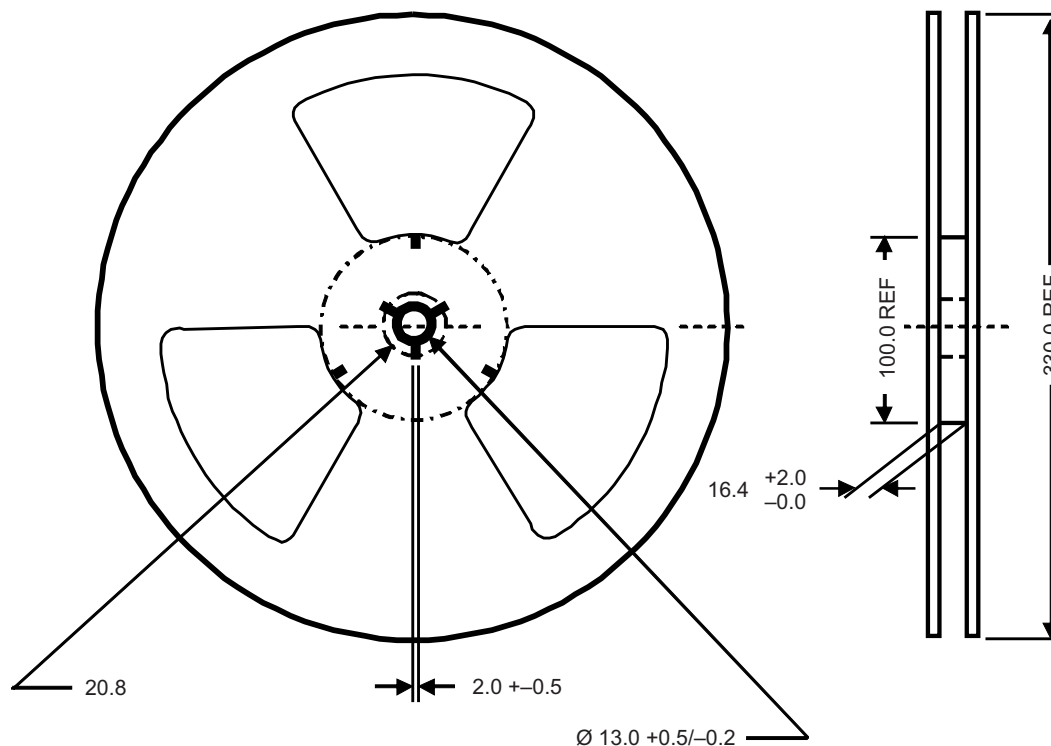

SWRS121-006

Figure 9-5. Reel Dimensions (mm)

9.2.7 Packing Method

The end of the leader tape is secured by drafting tape. The reel is packed in a moisture barrier bag fastened by heat-sealing (see Figure 9-6).

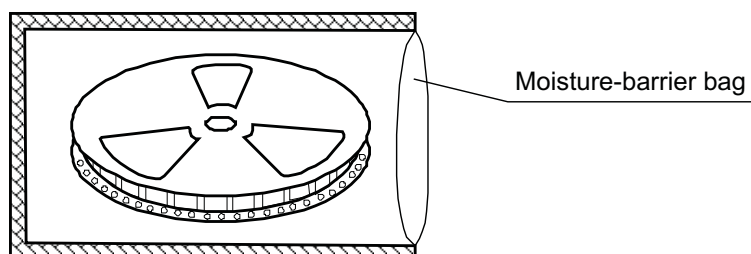

reelpk_swrs064

Figure 9-6. Reel Packing Method

CAUTION

This integrated circuit can be damaged by ESD. Texas Instruments recommends that all integrated circuits be handled with appropriate precautions. Failure to observe proper handling and installation procedures can cause damage. ESD damage can range from subtle performance degradation to complete device failure. Precision integrated circuits may be more susceptible to damage because very small parametric changes could cause devices not to meet their published specifications.

9.2.8 Packing Specification

9.2.8.1 Reel Box

Each moisture-barrier bag is packed into a reel box, as shown in [Figure 9-7](#).

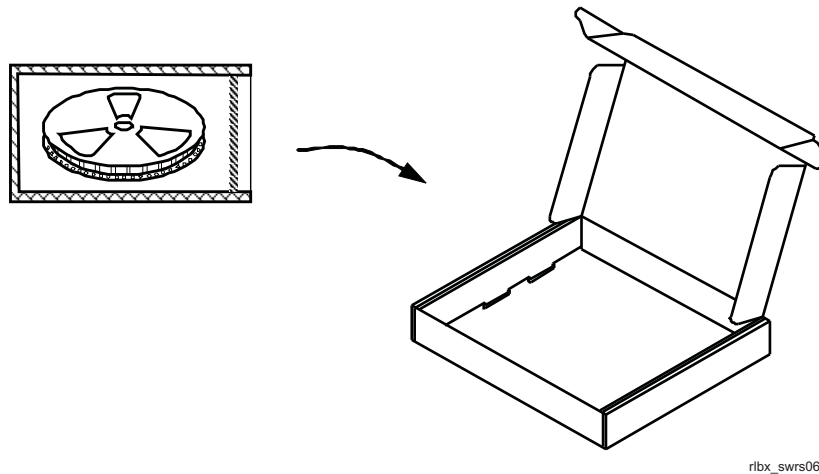

rlbx_swrs064

Figure 9-7. Reel Box (Carton)

9.2.8.2 Reel Box Material

The reel box is made from corrugated fiberboard.

9.2.8.3 Shipping Box

If the shipping box has excess space, filler (such as cushion) is added.

[Figure 9-8](#) shows a typical shipping box.

NOTE

The size of the shipping box may vary depending on the number of reel boxes packed.

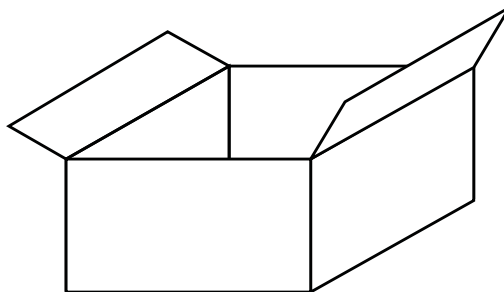

box_swrs064

Figure 9-8. Shipping Box (Carton)

9.2.8.4 Shipping Box Material

The shipping box is made from corrugated fiberboard.

PACKAGING INFORMATION

Orderable Device	Status (1)	Package Type	Package Drawing	Pins	Package Qty	Eco Plan (2)	Lead/Ball Finish (6)	MSL Peak Temp (3)	Op Temp (°C)	Device Marking (4/5)	Samples
CC2560ARVMR	NRND	VQFNP-MR	RVM	76	2500	Green (RoHS & no Sb/Br)	CU SN	Level-3-260C-168 HR	-40 to 85	CC2560A	
CC2560ARVMT	NRND	VQFNP-MR	RVM	76	250	Green (RoHS & no Sb/Br)	CU SN	Level-3-260C-168 HR	-40 to 85	CC2560A	
CC2560BRVMR	ACTIVE	VQFNP-MR	RVM	76	2500	Green (RoHS & no Sb/Br)	CU SN	Level-3-260C-168 HR	-40 to 85	CC2560B	Samples
CC2560BRVMT	ACTIVE	VQFNP-MR	RVM	76	250	Green (RoHS & no Sb/Br)	CU SN	Level-3-260C-168 HR	-40 to 85	CC2560B	Samples
CC2560BYFVR	ACTIVE	DSBGA	YFV	54	2500	Green (RoHS & no Sb/Br)	SNAGCU	Level-1-260C-UNLIM	-40 to 85	CC2560B	Samples
CC2560BYFVT	ACTIVE	DSBGA	YFV	54	250	Green (RoHS & no Sb/Br)	SNAGCU	Level-1-260C-UNLIM	-40 to 85	CC2560B	Samples
CC2564BRVMR	ACTIVE	VQFNP-MR	RVM	76	2500	Green (RoHS & no Sb/Br)	CU SN Call TI	Level-3-260C-168 HR	-40 to 85	CC2564B	Samples
CC2564BRVMT	ACTIVE	VQFNP-MR	RVM	76	250	Green (RoHS & no Sb/Br)	CU SN	Level-3-260C-168 HR	-40 to 85	CC2564B	Samples
CC2564NSRVMR	NRND	VQFNP-MR	RVM	76	2500	Green (RoHS & no Sb/Br)	CU SN	Level-3-260C-168 HR	-40 to 85	CC2564	
CC2564NSRVMT	NRND	VQFNP-MR	RVM	76	250	Green (RoHS & no Sb/Br)	CU SN	Level-3-260C-168 HR	-40 to 85	CC2564	
CC2564RVMR	NRND	VQFNP-MR	RVM	76	2500	Green (RoHS & no Sb/Br)	CU SN	Level-3-260C-168 HR	-40 to 85	CC2564	
CC2564RVMT	NRND	VQFNP-MR	RVM	76	250	Green (RoHS & no Sb/Br)	CU SN	Level-3-260C-168 HR	-40 to 85	CC2564	

(1) The marketing status values are defined as follows:

ACTIVE: Product device recommended for new designs.

LIFEBUY: TI has announced that the device will be discontinued, and a lifetime-buy period is in effect.

NRND: Not recommended for new designs. Device is in production to support existing customers, but TI does not recommend using this part in a new design.

PREVIEW: Device has been announced but is not in production. Samples may or may not be available.

OBSOLETE: TI has discontinued the production of the device.

(2) **RoHS:** TI defines "RoHS" to mean semiconductor products that are compliant with the current EU RoHS requirements for all 10 RoHS substances, including the requirement that RoHS substance do not exceed 0.1% by weight in homogeneous materials. Where designed to be soldered at high temperatures, "RoHS" products are suitable for use in specified lead-free processes. TI may reference these types of products as "Pb-Free".

RoHS Exempt: TI defines "RoHS Exempt" to mean products that contain lead but are compliant with EU RoHS pursuant to a specific EU RoHS exemption.

Green: TI defines "Green" to mean the content of Chlorine (Cl) and Bromine (Br) based flame retardants meet JS709B low halogen requirements of ≤ 1000 ppm threshold. Antimony trioxide based flame retardants must also meet the ≤ 1000 ppm threshold requirement.

(3) MSL, Peak Temp. - The Moisture Sensitivity Level rating according to the JEDEC industry standard classifications, and peak solder temperature.

(4) There may be additional marking, which relates to the logo, the lot trace code information, or the environmental category on the device.

(5) Multiple Device Markings will be inside parentheses. Only one Device Marking contained in parentheses and separated by a "~" will appear on a device. If a line is indented then it is a continuation of the previous line and the two combined represent the entire Device Marking for that device.

(6) Lead/Ball Finish - Orderable Devices may have multiple material finish options. Finish options are separated by a vertical ruled line. Lead/Ball Finish values may wrap to two lines if the finish value exceeds the maximum column width.

Important Information and Disclaimer: The information provided on this page represents TI's knowledge and belief as of the date that it is provided. TI bases its knowledge and belief on information provided by third parties, and makes no representation or warranty as to the accuracy of such information. Efforts are underway to better integrate information from third parties. TI has taken and continues to take reasonable steps to provide representative and accurate information but may not have conducted destructive testing or chemical analysis on incoming materials and chemicals. TI and TI suppliers consider certain information to be proprietary, and thus CAS numbers and other limited information may not be available for release.

In no event shall TI's liability arising out of such information exceed the total purchase price of the TI part(s) at issue in this document sold by TI to Customer on an annual basis.

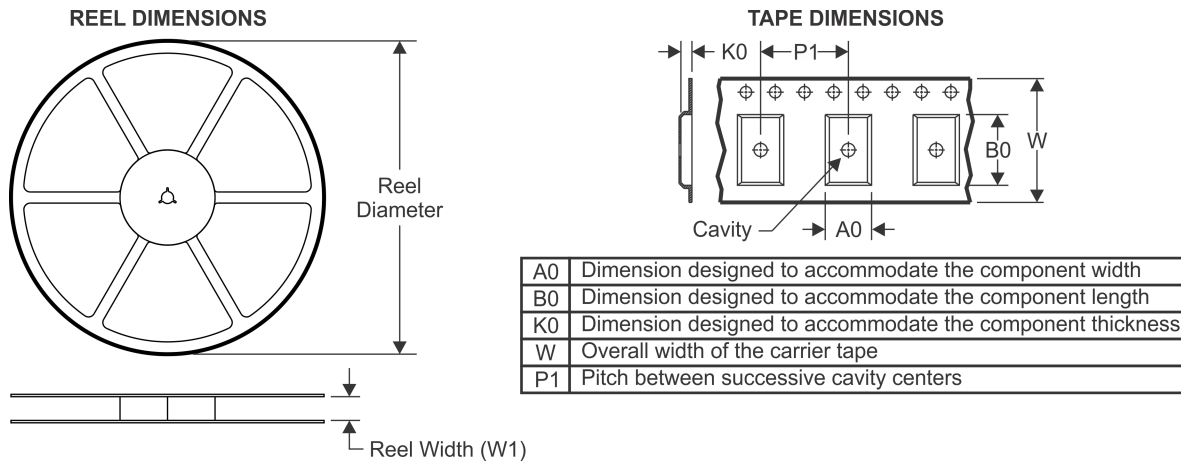
TAPE AND REEL INFORMATION

QUADRANT ASSIGNMENTS FOR PIN 1 ORIENTATION IN TAPE

*All dimensions are nominal

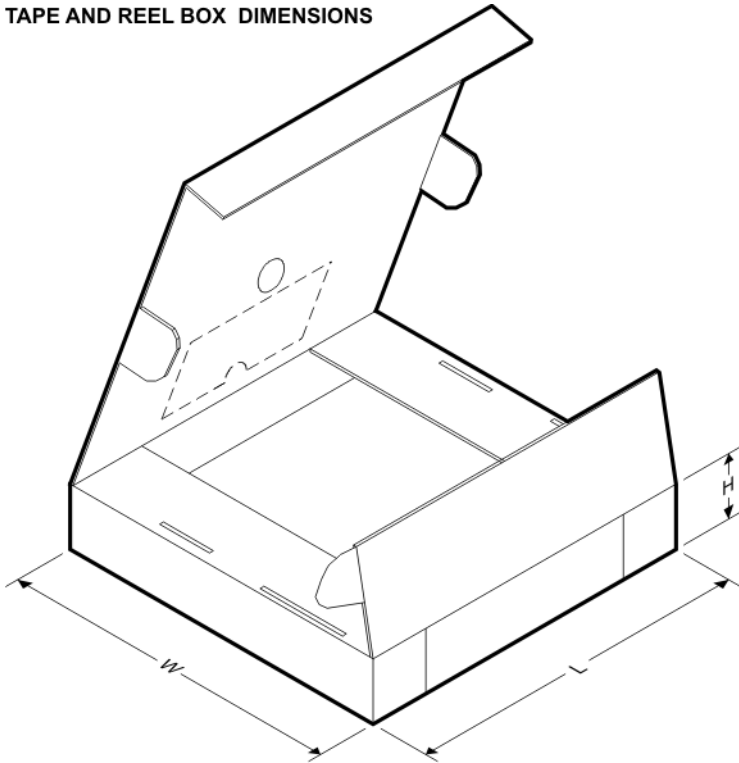
Device	Package Type	Package Drawing	Pins	SPQ	Reel Diameter (mm)	Reel Width W1 (mm)	A0 (mm)	B0 (mm)	K0 (mm)	P1 (mm)	W (mm)	Pin1 Quadrant
CC2560ARVMR	VQFN-MR	RVM	76	2500	330.0	16.4	8.35	8.35	1.7	12.0	16.0	Q2
CC2560ARVMT	VQFN-MR	RVM	76	250	180.0	16.4	8.35	8.35	1.7	12.0	16.0	Q2
CC2560BRVMR	VQFN-MR	RVM	76	2500	330.0	16.4	8.35	8.35	1.7	12.0	16.0	Q2
CC2560BYFVR	DSBGA	YFV	54	2500	330.0	12.4	3.1	3.43	0.7	4.0	12.0	Q1
CC2564BRVMR	VQFN-MR	RVM	76	2500	330.0	16.4	8.35	8.35	1.7	12.0	16.0	Q2
CC2564BRVMT	VQFN-MR	RVM	76	250	180.0	16.4	8.35	8.35	1.7	12.0	16.0	Q2
CC2564RVMR	VQFN-MR	RVM	76	2500	330.0	16.4	8.35	8.35	1.7	12.0	16.0	Q2
CC2564RVMT	VQFN-MR	RVM	76	250	180.0	16.4	8.35	8.35	1.7	12.0	16.0	Q2

TAPE AND REEL BOX DIMENSIONS

*All dimensions are nominal

Device	Package Type	Package Drawing	Pins	SPQ	Length (mm)	Width (mm)	Height (mm)
CC2560ARVMR	VQFNP-MR	RVM	76	2500	350.0	350.0	43.0
CC2560ARVMT	VQFNP-MR	RVM	76	250	213.0	191.0	55.0
CC2560BRVMR	VQFNP-MR	RVM	76	2500	350.0	350.0	43.0
CC2560BYFVR	DSBGA	YFV	54	2500	367.0	367.0	35.0
CC2564BRVMR	VQFNP-MR	RVM	76	2500	350.0	350.0	43.0
CC2564BRVMT	VQFNP-MR	RVM	76	250	213.0	191.0	55.0
CC2564RVMR	VQFNP-MR	RVM	76	2500	350.0	350.0	43.0
CC2564RVMT	VQFNP-MR	RVM	76	250	213.0	191.0	55.0

YFV (R-XBGA-N54)

DIE-SIZE BALL GRID ARRAY (WCSP)

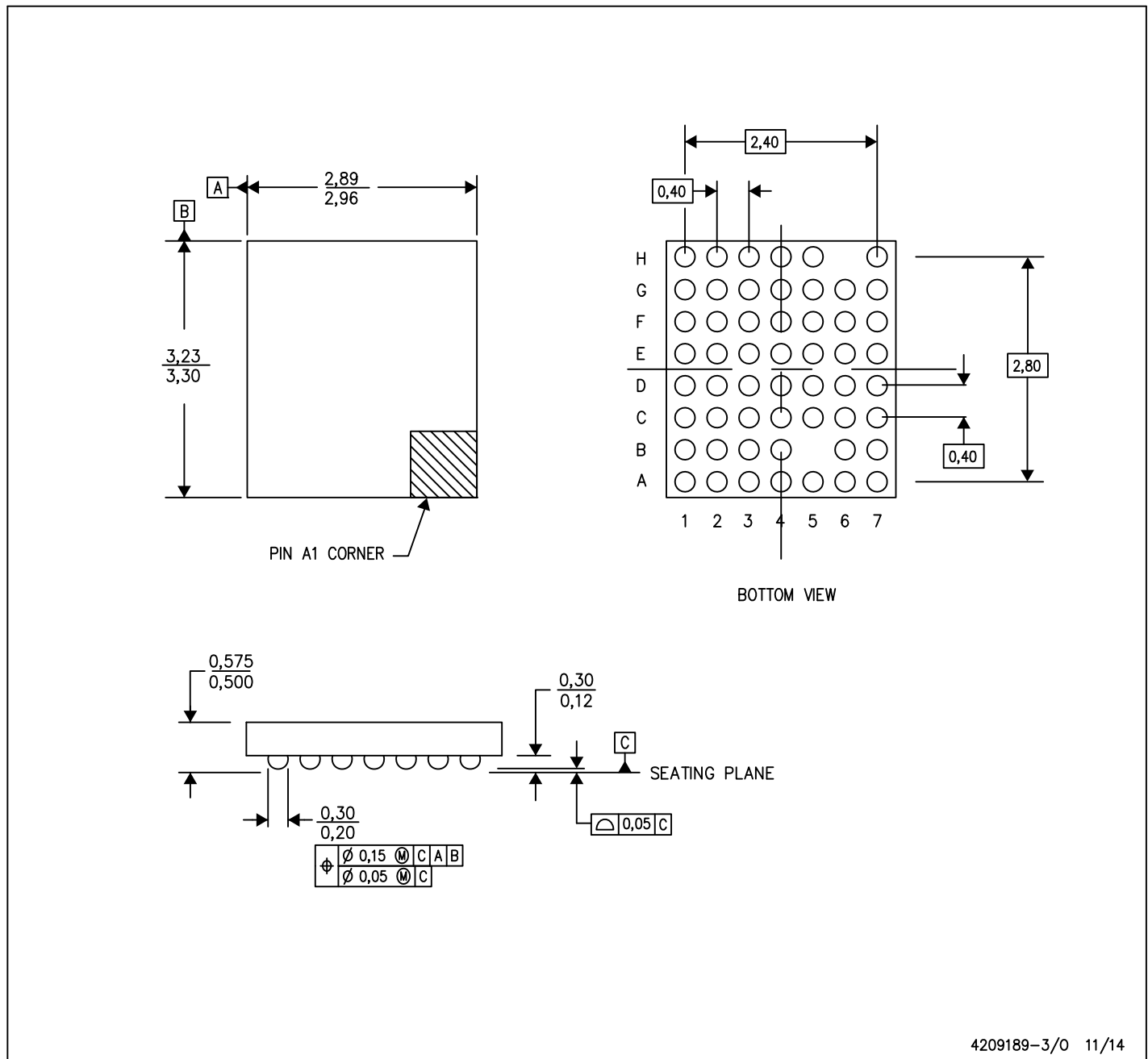

- NOTES:
- A. All linear dimensions are in millimeters. Dimensioning and tolerancing per ASME Y14.5M-1994.
 - B. This drawing is subject to change without notice.
 - C. NanoFree™ package configuration.
 - D. This package contains Pb-free balls.

NanoFree is a trademark of Texas Instruments.

RVM (S-PVQFN-N76)

PLASTIC QUAD FLATPACK NO-LEAD

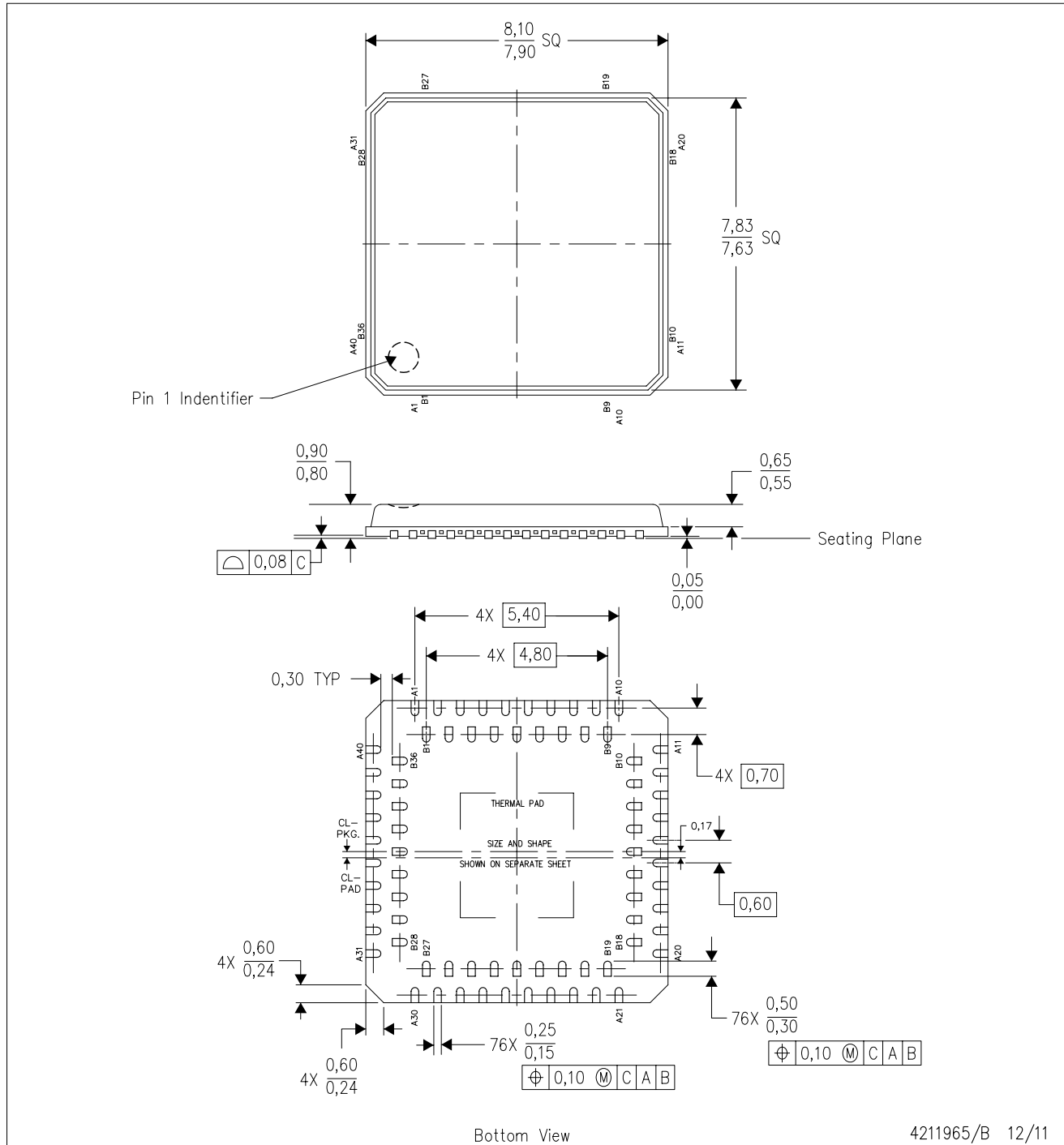

- NOTES:
- All linear dimensions are in millimeters. Dimensioning and tolerancing per ASME Y14.5-1994.
 - This drawing is subject to change without notice.
 - QFN (Quad Flatpack No-Lead) Package configuration.
 - The package thermal pad must be soldered to the board for thermal and mechanical performance.
 - See the additional figure in the Product Data Sheet for details regarding the exposed thermal pad features and dimensions.

IMPORTANT NOTICE AND DISCLAIMER

TI PROVIDES TECHNICAL AND RELIABILITY DATA (INCLUDING DATASHEETS), DESIGN RESOURCES (INCLUDING REFERENCE DESIGNS), APPLICATION OR OTHER DESIGN ADVICE, WEB TOOLS, SAFETY INFORMATION, AND OTHER RESOURCES "AS IS" AND WITH ALL FAULTS, AND DISCLAIMS ALL WARRANTIES, EXPRESS AND IMPLIED, INCLUDING WITHOUT LIMITATION ANY IMPLIED WARRANTIES OF MERCHANTABILITY, FITNESS FOR A PARTICULAR PURPOSE OR NON-INFRINGEMENT OF THIRD PARTY INTELLECTUAL PROPERTY RIGHTS.

These resources are intended for skilled developers designing with TI products. You are solely responsible for (1) selecting the appropriate TI products for your application, (2) designing, validating and testing your application, and (3) ensuring your application meets applicable standards, and any other safety, security, or other requirements. These resources are subject to change without notice. TI grants you permission to use these resources only for development of an application that uses the TI products described in the resource. Other reproduction and display of these resources is prohibited. No license is granted to any other TI intellectual property right or to any third party intellectual property right. TI disclaims responsibility for, and you will fully indemnify TI and its representatives against, any claims, damages, costs, losses, and liabilities arising out of your use of these resources.

TI's products are provided subject to TI's Terms of Sale (www.ti.com/legal/termsofsale.html) or other applicable terms available either on ti.com or provided in conjunction with such TI products. TI's provision of these resources does not expand or otherwise alter TI's applicable warranties or warranty disclaimers for TI products.

Mailing Address: Texas Instruments, Post Office Box 655303, Dallas, Texas 75265
Copyright © 2019, Texas Instruments Incorporated

Looking for pricing, stock, or lifecycle information?

Click below to explore more details on WIN SOURCE:

 [View CC2564BYFVR on WIN SOURCE](#)

 [Texas Instruments](#) Information

Optimize Your Supply Chain with WIN SOURCE Solutions

-  Global Sourcing Solution
-  Obsolete Management
-  Cost Control Management
-  Shortage Management
-  Alternative Solution
-  Excess Inventory Management