



**THE DATASHEET OF
HMC903LP3ETR**



FEATURES

- Low noise figure: 1.7 dB typical at 6 GHz to 16 GHz**
- High gain: 18.5 dB typical at 6 GHz to 16 GHz**
- Output power for 1 dB compression (P1dB): 14.5 dBm typical at 6 GHz to 16 GHz**
- Single-supply voltage: 3.5 V at 80 mA typical**
- Output third-order intercept (IP3): 25 dBm typical**
- 50 Ω matched input/output**
- Self biased with optional bias control for I_{DQ} reduction**
- 16-lead, 3 mm \times 3 mm, LFCSP package**

APPLICATIONS

- Point to point radios**
- Point to multipoint radios**
- Military and space**
- Test instrumentation**

GENERAL DESCRIPTION

The **HMC903LP3E** is a self biased, gallium arsenide (GaAs), monolithic microwave integrated circuit (MMIC), pseudomorphic (pHEMT), low noise amplifier (LNA) with an option bias control for I_{DQ} reduction. It is housed in a 16-lead, 3 mm \times 3 mm, LFCSP package. The **HMC903LP3E** amplifier operates from 6 GHz to 17 GHz, providing 18.5 dB of small signal gain and 1.7 dB noise figure in the 6 GHz to 16 GHz band, and an output IP3 of 25 dBm full band 6 GHz to 17 GHz, while requiring only 80 mA from a 3.5 V supply.

FUNCTIONAL BLOCK DIAGRAM

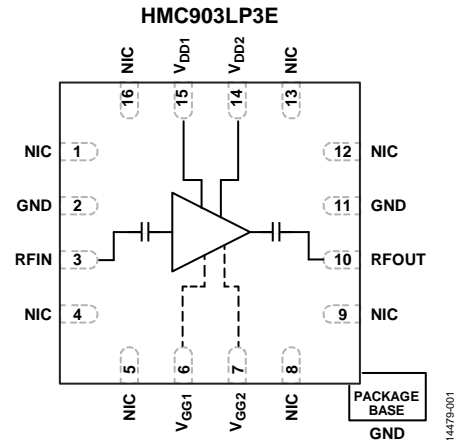

Figure 1.

The P1dB output power of 14.5 dBm enables the LNA to function as a local oscillator (LO) driver for balanced, I/Q or image reject mixers. The **HMC903LP3E** also features an input and an output that are dc blocked and internally matched to 50 Ω , making it ideal for high capacity microwave radios and video satellite (VSAT) applications.

TABLE OF CONTENTS

Features 1
 Applications 1
 Functional Block Diagram 1
 General Description 1
 Revision History 2
 Specifications 3
 6 GHz to 16 GHz Frequency Range 3
 16 GHz to 17 GHz Frequency Range 3
 Absolute Maximum Ratings 4
 Thermal Resistance 4
 ESD Caution 4

Pin Configuration and Function Descriptions 5
 Interface Schematics 5
 Typical Performance Characteristics 6
 Theory of Operation 9
 Applications Information 10
 Recommended Bias Sequence During Power Up 10
 Recommended Bias Sequence During Power Down 10
 Evaluation PCB 11
 Typical Application Circuits 12
 Outline Dimensions 13
 Ordering Guide 13

REVISION HISTORY

7/2017—Rev. F to Rev. G
 Changed HMC903 to HMC903LP3E Throughout
 Changes to Figure 1 1
 Changes to RF Input Parameter, Table 3 4

This Hittite Microwave product data sheet has been reformatted to the styles and standards of Analog Devices, Inc.

1/2017—v06.0816 (HMC903LP3E) to Rev. F
 Updated Format Universal
 Changes to Features Section, Figure 1, and General Description Section 1

Add Thermal Resistance Section and Table 5; Renumbered Sequentially 4
 Changes to Figure 2 and Table 5 5
 Added Theory of Operation Section 9
 Added Applications Information Section 10
 Updated Outline Dimensions 13
 Added Ordering Guide 13

SPECIFICATIONS

$T_A = 25^\circ\text{C}$, $V_{DD1} = V_{DD2} = 3.5\text{ V}$, $I_{DQ} = 80\text{ mA}$ ($V_{GG1} = V_{GG2} = \text{open}$ for normal, self biased operation), unless otherwise noted.

6 GHz TO 16 GHz FREQUENCY RANGE

Table 1.

Parameter	Min	Typ	Max	Unit
GAIN	16.5	18.5		dB
Gain Variation over Temperature		0.012		dB/ $^\circ\text{C}$
NOISE FIGURE ¹		1.7	2.2	dB
RETURN LOSS				
Input		12		dB
Output		12		dB
OUTPUT POWER				
For 1 dB Compression (P1dB) ¹	13	14.5		dBm
Saturated (P_{SAT}) ¹		16.5		dBm
OUTPUT THIRD-ORDER INTERCEPT (IP3)	22	25		dBm
SUPPLY CURRENT (I_{DQ})		80	110	mA

¹ Board loss removed from gain, power, and noise figure measurements.

16 GHz TO 17 GHz FREQUENCY RANGE

Table 2.

Parameter	Min	Typ	Max	Unit
GAIN	15	18		dB
Gain Variation over Temperature		0.012		dB/ $^\circ\text{C}$
NOISE FIGURE ¹		2.2	2.5	dB
RETURN LOSS				
Input		11		dB
Output		14		dB
OUTPUT POWER				
For 1 dB Compression (P1dB) ¹	12	13		dBm
Saturated (P_{SAT}) ¹		16.5		dBm
OUTPUT THIRD-ORDER INTERCEPT (IP3)	22	25		dBm
SUPPLY CURRENT (I_{DQ})		80	110	mA

¹ Board loss removed from gain, power, and noise figure measurements.

ABSOLUTE MAXIMUM RATINGS

Table 3.

Parameter	Rating
Drain Bias Voltage	4.5 V
RF Input Power	20 dBm
Gate Bias Voltage	
V_{GG1}	-0.8 V to +0.2 V
V_{GG2}	-0.8 V to +0.2 V
Continuous Power Dissipation, P_{DISS} ($T_A = 85^\circ\text{C}$, Derate 6.9 mW/ $^\circ\text{C}$ Above 85°C)	0.45 W
Channel Temperature	150 $^\circ\text{C}$
Maximum Peak Reflow Temperature	260 $^\circ\text{C}$
Storage Temperature	-65 $^\circ\text{C}$ to +85 $^\circ\text{C}$
Operating Temperature	-40 $^\circ\text{C}$ to +85 $^\circ\text{C}$
ESD Sensitivity (Human Body Model)	Class 0, Passed 150 V

Stresses at or above those listed under Absolute Maximum Ratings may cause permanent damage to the product. This is a stress rating only; functional operation of the product at these or any other conditions above those indicated in the operational section of this specification is not implied. Operation beyond the maximum operating conditions for extended periods may affect product reliability.

THERMAL RESISTANCE

Thermal performance is directly linked to printed circuit board (PCB) design and operating environment. Careful attention to PCB thermal design is required.

Table 4. Thermal Resistance

Package Type ¹	θ_{JC}	Unit
HCP-16-1	144.8	$^\circ\text{C}/\text{W}$

¹Thermal impedance simulated values are based on JEDEC 2s2p thermal test board. See JEDEC JESD51.

ESD CAUTION



ESD (electrostatic discharge) sensitive device.

Charged devices and circuit boards can discharge without detection. Although this product features patented or proprietary protection circuitry, damage may occur on devices subjected to high energy ESD. Therefore, proper ESD precautions should be taken to avoid performance degradation or loss of functionality.

PIN CONFIGURATION AND FUNCTION DESCRIPTIONS

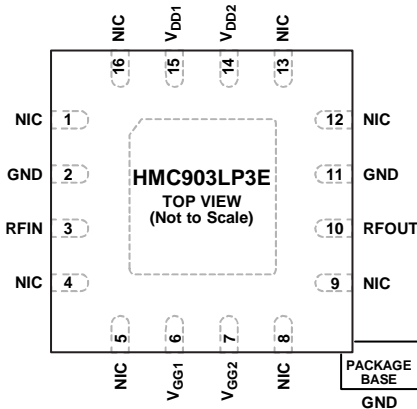

NOTES
 1. NIC = NOT INTERNALLY CONNECTED.
 2. EXPOSED PAD. THE PACKAGE BOTTOM HAS AN EXPOSED METAL GROUND PADDLE THAT MUST CONNECT TO RF/DC GROUND.

14479-002

Figure 2. Pin Configuration

Table 5. Pin Function Descriptions

Pin No.	Mnemonic	Description
1, 4, 5, 8, 9, 12, 13, 16	NIC	Not Internally Connected. However, all data shown was measured with these pins connected to RF/dc ground externally.
2, 11	GND	Ground. Connect these pins to RF/dc ground. See Figure 3 for the interface schematic.
3	RFIN	RF Input. This pin is ac-coupled and matched to 50 Ω. See Figure 4 for the interface schematic.
6, 7	V _{GG1} , V _{GG2}	Optional Gate Controls for the Amplifier. If left open, the amplifier runs self biased at the standard current. Applying a negative voltage reduces the drain current. External capacitors are required (see Figure 24). See Figure 5 for the interface schematic.
10	RFOUT	RF Output. This pin is ac-coupled and matched to 50 Ω. See Figure 6 for the interface schematic.
14, 15	V _{DD1} , V _{DD2}	Power Supply Voltages for the Amplifier. See assembly for the required external components (see Figure 23 and Figure 24). See Figure 7 for the interface schematic.
	EPAD	Exposed Pad. The package bottom has an exposed metal ground paddle that must connect to RF/dc ground.

INTERFACE SCHEMATICS



Figure 3. GND Interface Schematic

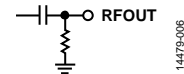

Figure 6. RFOUT Interface Schematic

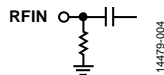

Figure 4. RFIN Interface Schematic

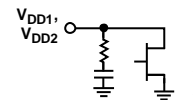

Figure 7. V_{DD1} and V_{DD2} Interface Schematic

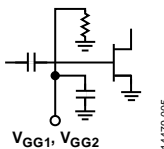

Figure 5. V_{GG1} and V_{GG2} Interface Schematic

TYPICAL PERFORMANCE CHARACTERISTICS

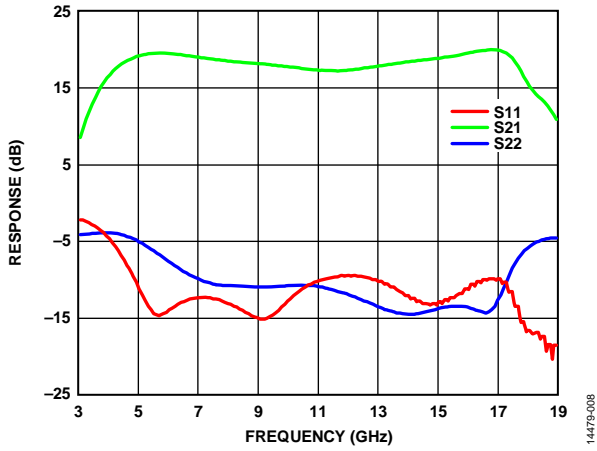

Figure 8. Broadband Gain and Return Loss (Board Loss Removed from Gain, Power, and Noise Figure Measurements) vs. Frequency

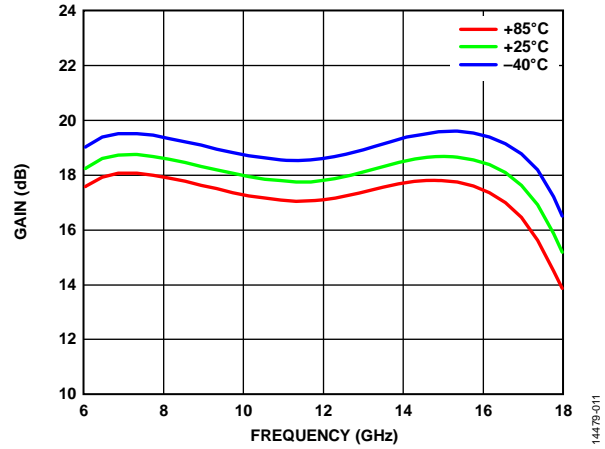

Figure 11. Gain vs. Frequency for Various Temperatures (Board Loss Removed from Gain, Power, and Noise Figure Measurements)

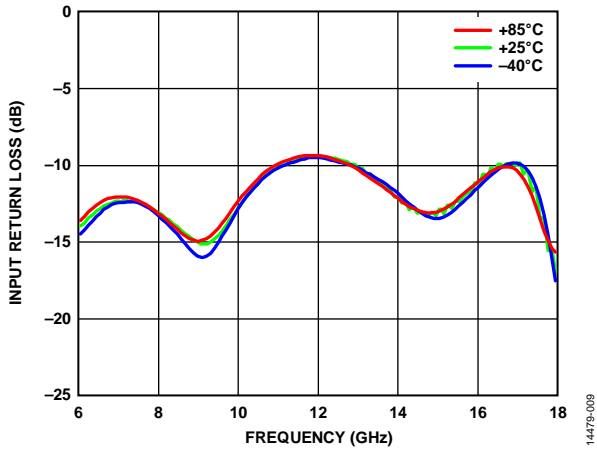

Figure 9. Input Return Loss vs. Frequency for Various Temperatures

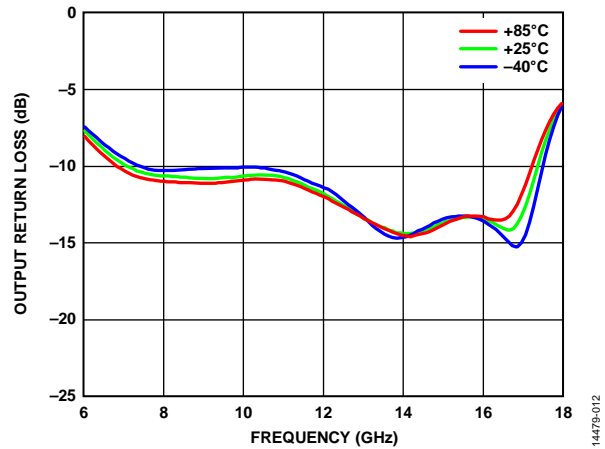

Figure 12. Output Return Loss vs. Frequency for Various Temperatures

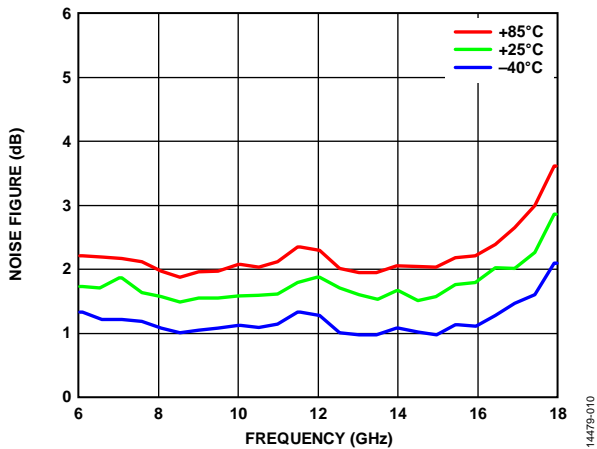

Figure 10. Noise Figure vs. Frequency for Various Temperatures (Board Loss Removed from Gain, Power, and Noise Figure Measurements)

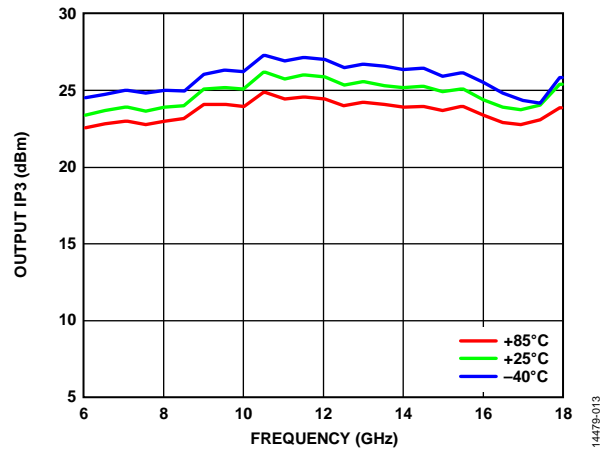

Figure 13. Output Third-Order Intercept (IP3) vs. Frequency for Various Temperatures

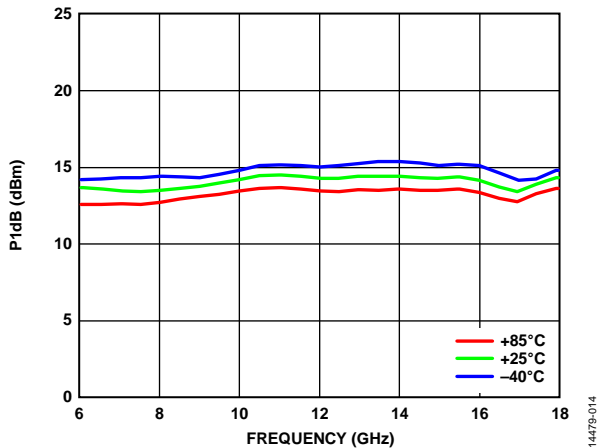

Figure 14. Output Power for 1 dB Compression (P_{1dB}) vs. Frequency for Various Temperatures (Board Loss Removed from Gain, Power, and Noise Figure Measurements)

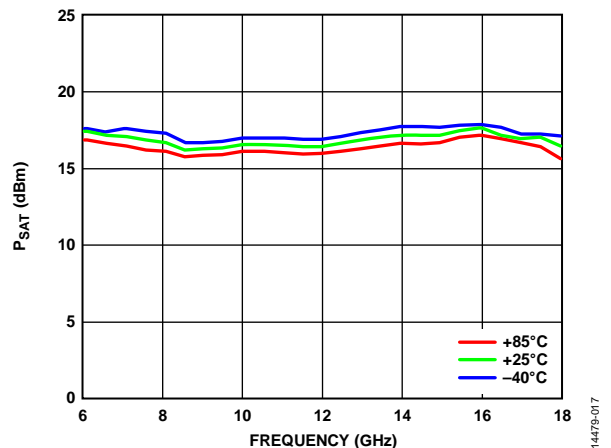

Figure 17. Saturated Output Power (P_{SAT}) vs. Frequency for Various Temperatures (Board Loss Removed from Gain, Power, and Noise Figure Measurements)

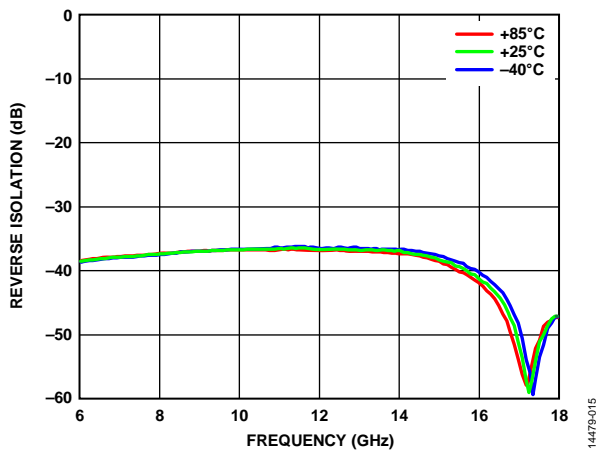

Figure 15. Reverse Isolation vs. Frequency for Various Temperatures

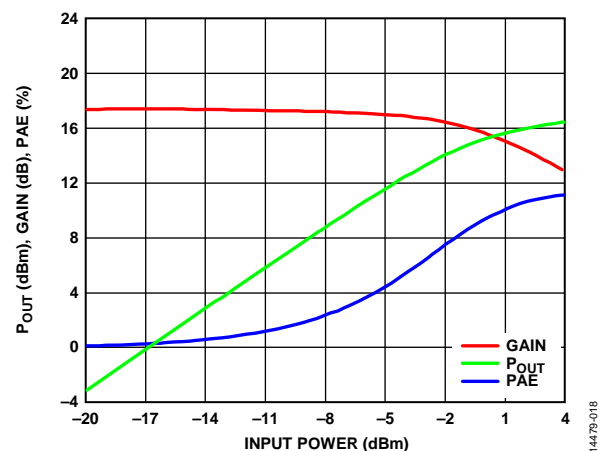

Figure 18. Output Power (P_{OUT}), Gain, and Power Added Efficiency (PAE) vs. Input Power (Board Loss Removed from Gain, Power, and Noise Figure Measurements)

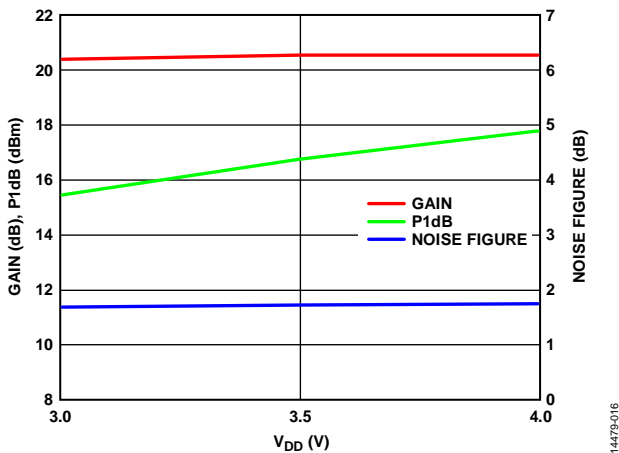

Figure 16. Gain, Output Power for 1 dB Compression (P_{1dB}), and Noise Figure vs. Supply Voltage (V_{DD}) at 12 GHz (Board Loss Removed from Gain, Power, and Noise Figure Measurements)

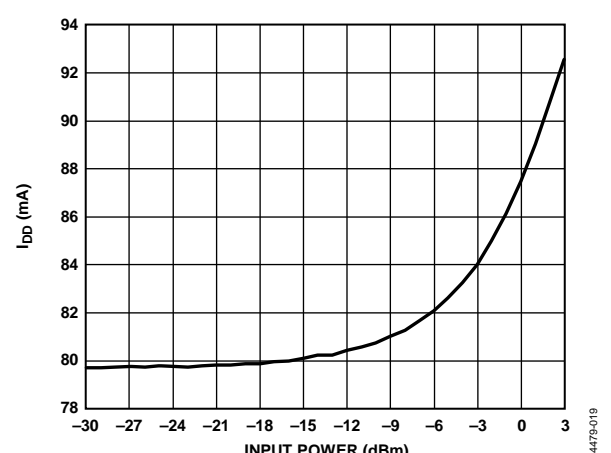
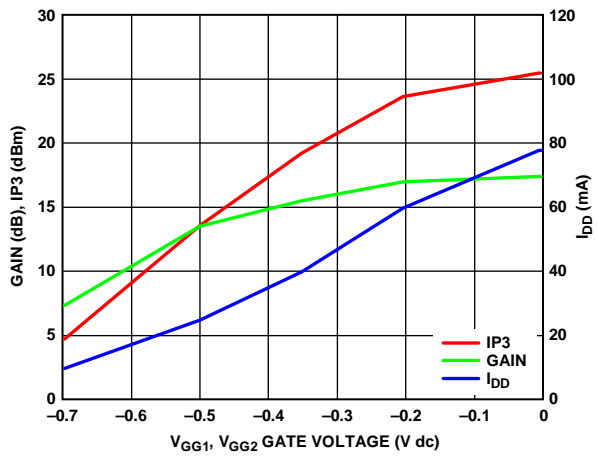

Figure 19. Supply Current (I_{DD}) vs. Input Power (Board Loss Removed from Gain Measurement and Data Taken at $V_{DD1} = V_{DD2} = 3\text{ V}$)



14479-020

Figure 20. Gain, Output Third-Order Intercept (IP3), and Supply Current (I_{DD}) vs. V_{GG1}, V_{GG2} Gate Voltage

THEORY OF OPERATION

The [HMC903LP3E](#) is a gallium arsenide (GaAs), monolithic microwave integrated circuit (MMIC), pseudomorphic (pHEMT), low noise amplifier. The [HMC903LP3E](#) amplifier uses two gain stages in series, and the basic schematic of the amplifier is shown in Figure 21, which forms a low noise amplifier operating from 6 GHz to 17 GHz with excellent noise figure performance.

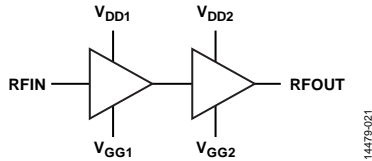

Figure 21. Basic Schematic of the Amplifier

The [HMC903LP3E](#) has single-ended input and output ports whose impedances are nominally equal to $50\ \Omega$ over the 6 GHz to 17 GHz frequency range. Consequently, it can directly insert into a $50\ \Omega$ system with no required impedance matching circuitry, which also means that multiple [HMC903LP3E](#) amplifiers can be cascaded back to back without the need for external matching circuitry.

The input and output impedances are sufficiently stable vs. variations in temperature and supply voltage that no impedance matching compensation is required.

Note that it is critical to supply very low inductance ground connections to the GND pins and to the package base exposed pad to ensure stable operation. To achieve optimal performance from the [HMC903LP3E](#) and to prevent damage to the device, do not exceed the absolute maximum ratings.

APPLICATIONS INFORMATION

Figure 22 shows the basic connections for operating the [HMC903LP3E](#). Both the RFIN and RFOUT ports have on-chip dc block capacitors that eliminate the need for external ac coupling capacitors.

The [HMC903LP3E](#) has V_{GG1} and V_{GG2} optional gate bias pins. When these pins are left open, the amplifier runs in self biased operation with a typical $I_{DQ} = 80$ mA, when $V_{DD1}/V_{DD2} = 3.5$ V. When using the V_{GG1} and V_{GG2} gate bias pins, follow the recommended bias sequencing so that the amplifier is not damaged.

RECOMMENDED BIAS SEQUENCE DURING POWER UP

The recommended bias sequence to power up the [HMC903LP3E](#) is as follows:

1. Connect to GND.
2. Set V_{GG1} and V_{GG2} to -2 V.
3. Set V_{DD1} and V_{DD2} to 3.5 V.
4. Increase V_{GG1} and V_{GG2} to achieve a typical $I_{DQ} = 80$ mA.
5. Apply the RF signal.

RECOMMENDED BIAS SEQUENCE DURING POWER DOWN

The recommended bias sequence to power down the [HMC903LP3E](#) is as follows:

1. Turn off the RF signal.
2. Decrease V_{GG1} and V_{GG2} to -2 V to achieve a typical $I_{DQ} = 0$ mA.
3. Decrease V_{DD1} and V_{DD2} to 0 V.
4. Increase V_{GG1} and V_{GG2} to 0 V.

Unless otherwise noted, all measurements and data shown were taken using the typical application circuit (see Figure 23), with the evaluation board (see Figure 22) and biased per the conditions in this section. The V_{DD1} and V_{DD2} pins are connected together, similarly the V_{GG1} and V_{GG2} pins are also connected together. The bias conditions shown in this section are the operating points recommended to optimize the overall performance. Operation using other bias conditions may provide performance that differs from what is shown in this data sheet.

Decreasing the V_{DD1} and V_{DD2} levels has negligible effect on the gain and noise figure performance; however, they reduce the P1dB. This behavior is shown in Figure 8 thru Figure 20. For applications where the P1dB requirement is not stringent, the [HMC903LP3E](#) can be down biased to reduce power consumption.

EVALUATION PCB

The circuit board used in this application must use RF circuit design techniques. Signal lines must have 50 Ω impedance, and the package ground leads and exposed paddle must be connected directly to the ground plane similar to that shown in Figure 22.

Use a sufficient number of via holes to connect the top and bottom ground planes. Mount the evaluation PCB to an appropriate heat sink. The evaluation PCB shown is available from Analog Devices, Inc., upon request.

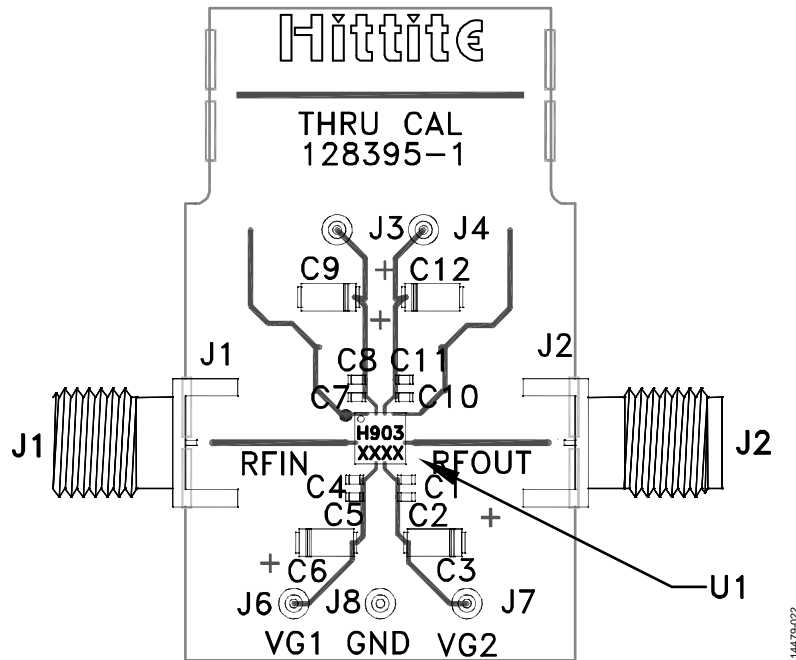
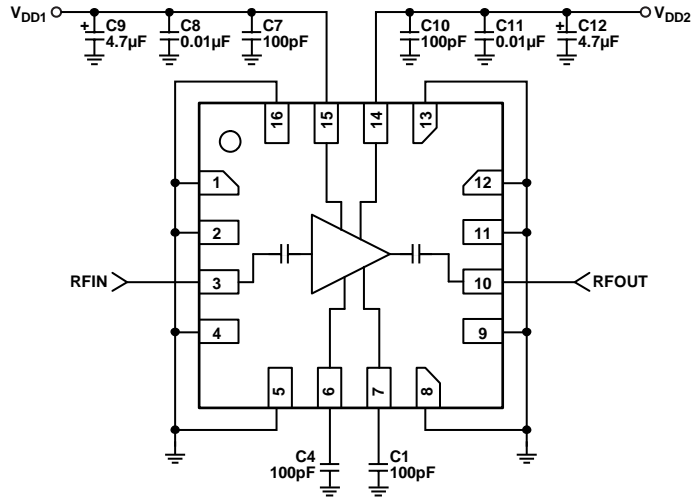

Figure 22. Evaluation PCB (128395-1)

Table 6. List of Materials for the Evaluation PCB

Component	Description
J1, J2	SMA connectors
J3, J4, J6 to J8	DC pins
C1, C4, C7, C10	100 pF capacitors, 0402 package
C2, C5, C8, C11	0.01 μF capacitors, 0402 package
C3, C6, C9, C12	4.7 μF tantalum capacitors
U1	HMC903LP3E amplifier
PCB	128395-1 evaluation PCB; circuit board material: Rogers 4350 or Arlon 25FR

TYPICAL APPLICATION CIRCUITS



14479-023

Figure 23. Standard (Self Biased) Operation Typical Application Circuit

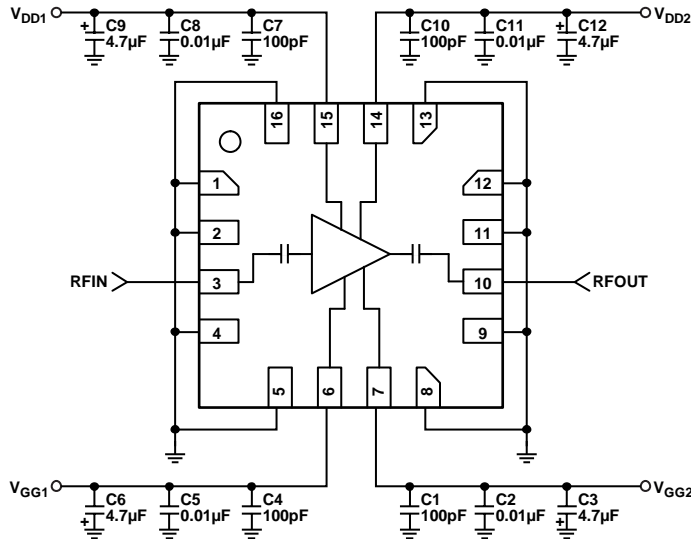

14479-024

Figure 24. Gate Control, Reduced Current Operation Typical Application Circuit

OUTLINE DIMENSIONS

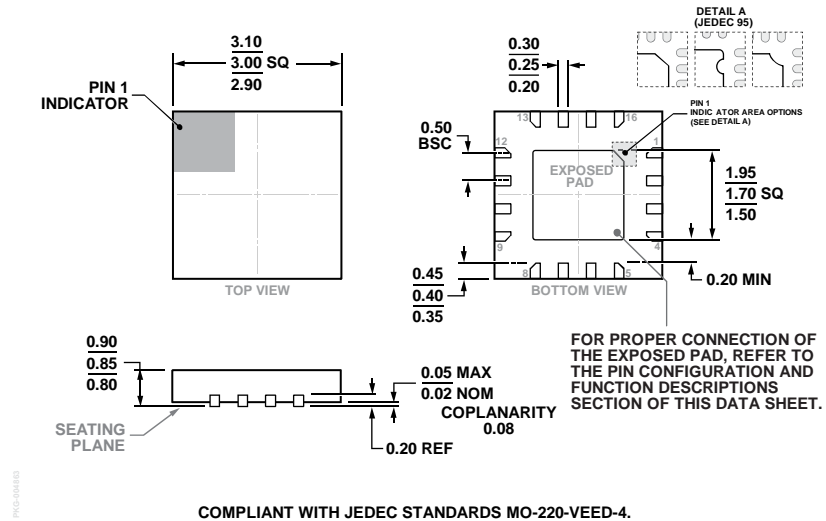

COMPLIANT WITH JEDEC STANDARDS MO-220-VEED-4.

Figure 25. 16-Lead Lead Frame Chip Scale Package [LFCSP]
 3 mm × 3 mm Body and 0.85 mm Package Height
 (HCP-16-1)
 Dimensions shown in millimeters

ORDERING GUIDE

Model ¹	Temperature Range	Lead Finish	Package Description	Package Option	Branding ²
HMC903LP3E	-40°C to +85°C	100% Matte Sn	16-Lead LFCSP	HCP-16-1	903 XXXX
HMC903LP3ETR	-40°C to +85°C	100% Matte Sn	16-Lead LFCSP	HCP-16-1	903 XXXX
129798-HMC903LP3E			Evaluation Board		

¹ The HMC903LP3E is a RoHS Compliant Part.
² The four digital lot number for the HMC903LP3E is XXXX.

Looking for pricing, stock, or lifecycle information?

Click below to explore more details on WIN SOURCE:

-  [View HMC903LP3ETR on WIN SOURCE](#)
-  [Analog Devices Inc. Information](#)

Optimize Your Supply Chain with WIN SOURCE Solutions

-  Global Sourcing Solution
-  Obsolete Management
-  Cost Control Management
-  Shortage Management
-  Alternative Solution
-  Excess Inventory Management