



**THE DATASHEET OF
TSS-53LNB3+**



**THE BIG DEAL**

- Wideband: 0.5-5 GHz
- Built-in Bypass switching
- Low Noise figure: 1.5 dB typ. at 2.0 GHz
- High Gain: 18.4 dB typ. at 2 GHz
- Ultra Flat Gain: 0.7 dB from 0.7 to 2.1 GHz
- P1dB: +15.1 dBm typ. at 2.0 GHz
- Minimal matching components
- Specified over full band operation

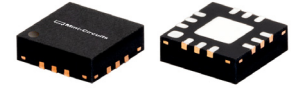

Generic photo used for illustration purposes only

CASE STYLE: DQ1225

+RoHS Compliant

The +Suffix identifies RoHS Compliance. See our web site for RoHS Compliance methodologies and qualifications

APPLICATIONS

- Wireless Base Station Systems
- Test and Measurement Systems
- Multi-Band Receivers

PRODUCT OVERVIEW

Mini-Circuits TSS-53LNB3+ is a low-noise amplifier offering industry-leading performance over its full frequency range from 500 MHz to 5 GHz. It contains internal switching, allowing the user control of the amplifier to handle both high and low signal levels by bypassing the LNA in the presence of large signals. The TSS-53LNB3+ utilizes E-PHEMT technology to achieve excellent noise figure performance in a unique cascade configuration enabling the combination of very wide band performance and flat gain. This model comes in a tiny, 3 x 3mm, 12-lead MCLP package.

KEY FEATURES

Feature	Advantages
Ultra-wideband: 500 MHz – 5 GHz	Ideal for a wide range of receiver applications including military, commercial wireless, and instrumentation.
Very flat gain	Ideal for broadband or multi-band applications. Just one, cost-efficient model required for multiple frequency usage.
Minimal external matching components required. 15 dB return loss typ.	Minimizes the need for external matching networks, simplifying circuit designs, and enabling the amplifier to operate over multiple bands in a single application circuit.
Internal bypass switch feature	Unique design handles low to high signal levels with minimal noise distortion.
Built-in DC blocking cap at RF-Out port & separate pads for RF-Out & Vdd	Simplifies biasing eliminates need for Bias-Tee at output.
Compact size: 3 x 3 x 0.9 mm	Saves space in dense system layouts. Low inductance, repeatable transitions, and excellent thermal contact.

**WIDEBAND**

Low Noise Bypass Amplifier **TSS-53LNB3+**

Mini-Circuits

ELECTRICAL SPECIFICATIONS¹ AT 25°C, Z_O=50Ω AND V_{DD}=3V, UNLESS OTHERWISE NOTED

Parameter	Condition (GHz)	Amplifier-ON			Amplifier-Bypass	Units
		Min.	Typ.	Max.	Typ.	
Frequency Range		0.5		5.0		GHz
Noise Figure	0.5		1.3		—	dB
	1.0		1.3		—	
	2.0		1.5		—	
	3.0		1.6		—	
	4.0		1.7		—	
Gain	0.5	—	19.5	—	-0.8	dB
	1.0	—	19.3	—	-0.8	
	2.0	16.5	18.4	20.2	-1.1	
	3.0	—	17.2	—	-1.3	
	4.0	—	16.1	—	-1.6	
Gain Flatness	0.5		±0.7		±0.2	dB
	1.0		±0.7		±0.2	
	2.0		±0.7		±0.2	
	3.0		±0.7		±0.2	
	4.0		±0.7		±0.2	
Input Return Loss	0.5	—	16.6		24.3	dB
	1.0	—	16.6		19.0	
	2.0	—	12.4		13.4	
	3.0	—	9.8		12.5	
	4.0	—	10.1		10.6	
Output Return Loss	0.5		18.5		24.1	dB
	1.0		18.3		17.7	
	2.0		18.8		13.2	
	3.0		12.9		13.5	
	4.0		10.2		11.5	
Output Power @1dB compression AMP-ON ² Input Power @1dB compression AMP-Bypass ²	0.5		13.6		28	dBm
	1.0		14.8		—	
	2.0		14.9		29	
	3.0		14.7		—	
	4.0		14.7		—	
Output IP3	0.5		25.2		28.7	dBm
	1.0		24.5		20.7	
	2.0		24.8		26.6	
	3.0		23.6		28.3	
	4.0		23.8		29.2	
Device Operating Voltage (Vdd)		2.7	3	3.3	3	V
Device Operating Current (Id)			42		2	mA
Enable Voltage (Ve)			3		0	V
Enable Control Current (Ie)			2.0		0	mA
DC Current (Id) Variation Vs. Temperature ³			-19		—	µA/°C
DC Current (Id) Variation Vs. Voltage			0.008		—	mA/mV
Thermal Resistance, junction-to-ground lead			60		—	°C/W

1. Measured on Mini-Circuits Characterization test board TB-780+. See Characterization Test Circuit (Fig. 1)

2. Current increases at P1dB

3. (Current at 85°C - Current at -45°C)/130





WIDEBAND

Low Noise Bypass Amplifier TSS-53LNB3+

Mini-Circuits

MAXIMUM RATINGS⁴

Parameter	Ratings
Operating Temperature (ground lead)	-40°C to 85°C
Storage Temperature	-65°C to 150°C
Total Power Dissipation	0.7 W
Input Power	8 dBm (continuous), 19 dBm (5 min max.)
Amplifier-ON	8 dBm (continuous), 19 dBm (5 min max.)
Amplifier Bypass	16 dBm (continuous), 29 dBm (5 min max.)
DC Voltage Vdd	7.0 V
DC Voltage Enable	7.0 V
Max. Voltage on pad 8	15 V

CONTROL VOLTAGE (V_E) FIG. 1

	Min.	Typ.	Max.	Units
Amplifier-ON	2.7	3.0	3.3	V
Amplifier-Bypass	0	—	0.5	V

5. Permanent damage may occur if any of these limits are exceeded.
Electrical maximum ratings are not intended for continuous normal operation.

SWITCHING SPECIFICATIONS (RISE/FALL TIME)

Parameter	Min.	Typ.	Max.	Units
Amplifier ON to Bypass	OFF TIME (50% Control to 10% RF)	—	55*	—
	FALL TIME (90 to 10% RF)	—	34	—
Amplifier Bypass to ON	ON TIME (50% Control to 90% RF)	—	960*	—
	RISE TIME (10% to 90% RF)	—	240	—
Control Voltage Leakage	—	65	—	mV

* Measured with ±25nS uncertainty

SIMPLIFIED SCHEMATIC AND BONDING PAD DESCRIPTION

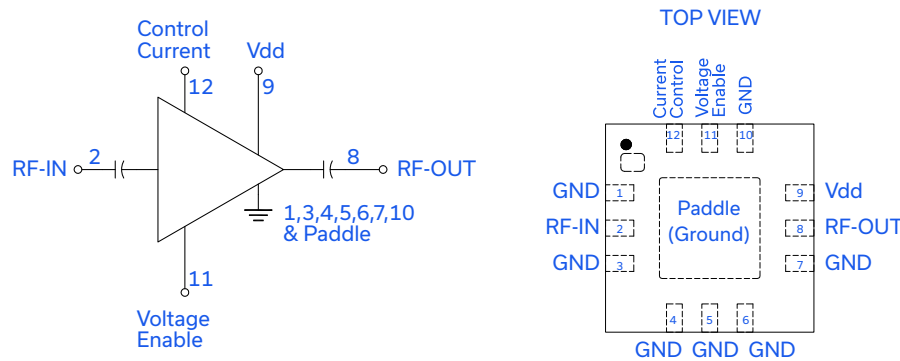

Function	Pad Number	Description (See Figure 2)
RF-IN	2	RF-Input pad. Connect to Ground Via L1. Add a DC blocking cap in series of appropriate value if required.
RF-OUT	8	RF-Output pad. No external DC blocking cap required.
Current Control	12	Control Current pad, voltage level on this pad sets the I _{dd} . Connect to pad 11 via 3.92 kΩ resistor.
Voltage Enable	11	Voltage Enable Pad. Voltage level on this pad determines Amplifier is ON or bypassed.
Vdd	9	Supply Voltage Pad. Connect to Vdd via L2.
Ground	1,3,4,5,6,7,10 & Paddle	Connect to ground. Use via holes as shown in "Suggested Layout for PCB Design" to reduce ground path inductance for best performance.





WIDEBAND

Low Noise Bypass Amplifier **TSS-53LNB3+**

CHARACTERIZATION TEST CIRCUIT

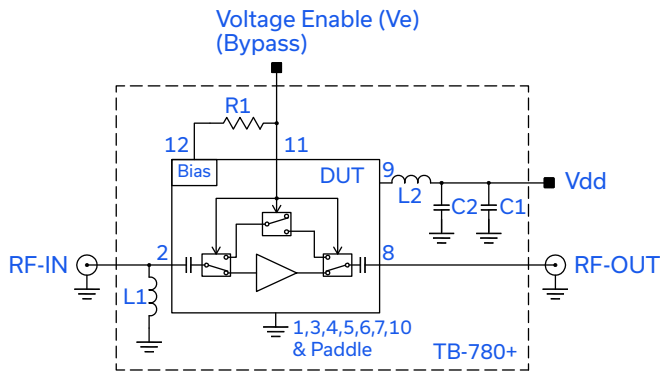

Component	Size	Value	Units
L1	0402	47	nH
L2	0402	56	nH
C1	0402	0.1	μ F
C2	0402	10	pF
R1	0402	3.92	K Ω

Fig 1. Block diagram of Test Circuit used for characterization. (DUT soldered on Mini-Circuits Characterization test board TB-780+)

Gain, Return loss, Output power at 1dB compression (P1 dB), output IP3 (OIP3) and noise figure measured using Agilent's N5242A PNA-X microwave network analyzer.

Conditions:

1. Gain and Return loss: Pin= -25dBm
2. Output IP3 (OIP3): Two tones, spaced 1 MHz apart, 0 dBm/tone at output.
3. Switching Time: Pin=-25 dBm at 500 MHz. Venable=3V at 10 kHz. Vd=3V.

RECOMMENDED APPLICATION CIRCUIT

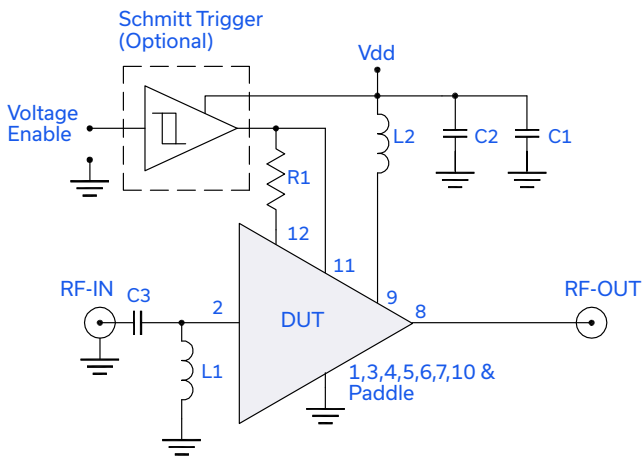

Component	Size	Value	Units
L1	0402	47	nH
L2	0402	56	nH
R1	0402	3.92	k Ω
C1	0402	0.1	μ F
C2	0402	10	pF
C3	0402	1000	pF
Schmitt Trigger	SN74LVC2G17DCKR Texas Instruments		—

Fig 2. Recommended Application Circuit.

PRODUCT MARKING



Marking may contain other features or characters for internal lot control





WIDEBAND

Low Noise Bypass Amplifier TSS-53LNB3+

Mini-Circuits

ADDITIONAL DETAILED TECHNICAL INFORMATION IS AVAILABLE ON OUR DASH BOARD. TO ACCESS [CLICK HERE](#)

Performance Data	Data Table Swept Graphs S-Parameter (S2P Files) Data Set (.zip file)
Case Style	DQ1225 Plastic package, exposed paddle lead finish: Matte-Tin
Tape & Reel Standard quantities available on reel	F66 7" reels with 20, 50, 100, 200, 500, 1K, or 2K devices
Suggested Layout for PCB Design	PL-421
Evaluation Board	TB-779+
Environmental Ratings	ENV12

ESD RATING

Human Body Model (HBM): Class 1A (250 to <500V) in accordance with ANSI/ESD STM 5.1 - 2001

Machine Model (MM): Class M1 (pass 50V) in accordance with ANSI/ESD STM5.2-1999

MSL RATING

Moisture Sensitivity: MSL1 in accordance with IPC/JEDEC J-STD-020D

MSL FLOW CHART

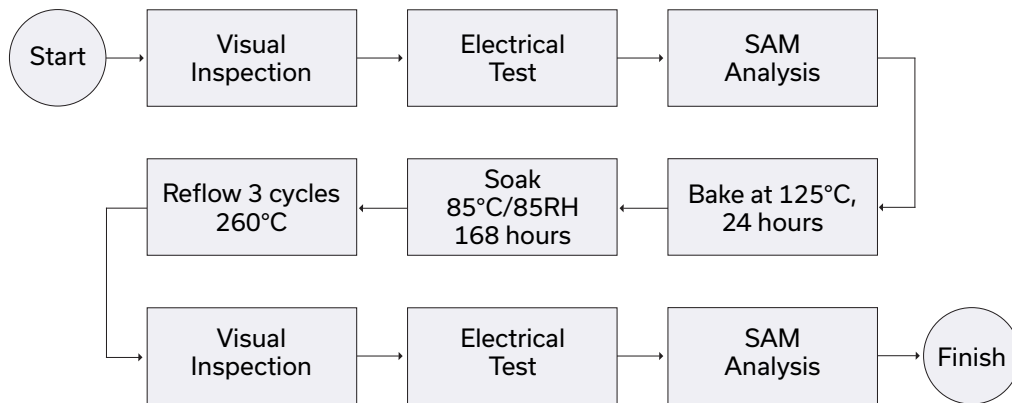



- NOTES**
- A. Performance and quality attributes and conditions not expressly stated in this specification document are intended to be excluded and do not form a part of this specification document.
 - B. Electrical specifications and performance data contained in this specification document are based on Mini-Circuit's applicable established test performance criteria and measurement instructions.
 - C. The parts covered by this specification document are subject to Mini-Circuits standard limited warranty and terms and conditions (collectively, "Standard Terms"); Purchasers of this part are entitled to the rights and benefits contained therein. For a full statement of the standard. Terms and the exclusive rights and remedies thereunder, please visit Mini-Circuits' website at www.minicircuits.com/MCLStore/terms.jsp



Looking for pricing, stock, or lifecycle information?

Click below to explore more details on WIN SOURCE:

-  [View TSS-53LNB3+ on WIN SOURCE](#)
-  [Mini-Circuits Information](#)

Optimize Your Supply Chain with WIN SOURCE Solutions

-  Global Sourcing Solution
-  Obsolete Management
-  Cost Control Management
-  Shortage Management
-  Alternative Solution
-  Excess Inventory Management