



**THE DATASHEET OF  
CY2CC9100XI**



# 1:10 Clock Fanout Buffer

## Features

- Low voltage operation
- Full range support:
  - 3.3 V
  - 2.5 V
  - 1.8 V
- Over voltage tolerant input hot swappable
- 1:10 Fanout
- Drives either a 50-Ohm or 75-Ohm load
- Low input capacitance
- Low output skew
- Low propagation delay
- Typical ( $t_{pd}$  less than 4 ns)
- High speed operation:
  - 200 MHz at 1.8 V
  - 650 MHz at 2.5 V and 3.3 V

- Industrial temperature range
- Available in SSOP package

## Functional Description

The Cypress series of network circuits are produced using advanced 0.35 micron CMOS technology, achieving the industry's fastest logic and buffers.

The Cypress CY2CC910 fanout buffer features one input and 10 outputs. It is ideal for conversion from and to 3.3 V, 2.5 V, and 1.8 V.

Designed for Data Communications clock management applications, the large fanout from a single input reduces loading on the input clock.

For a complete list of related documentation, [click here](#).

## Logic Block Diagram

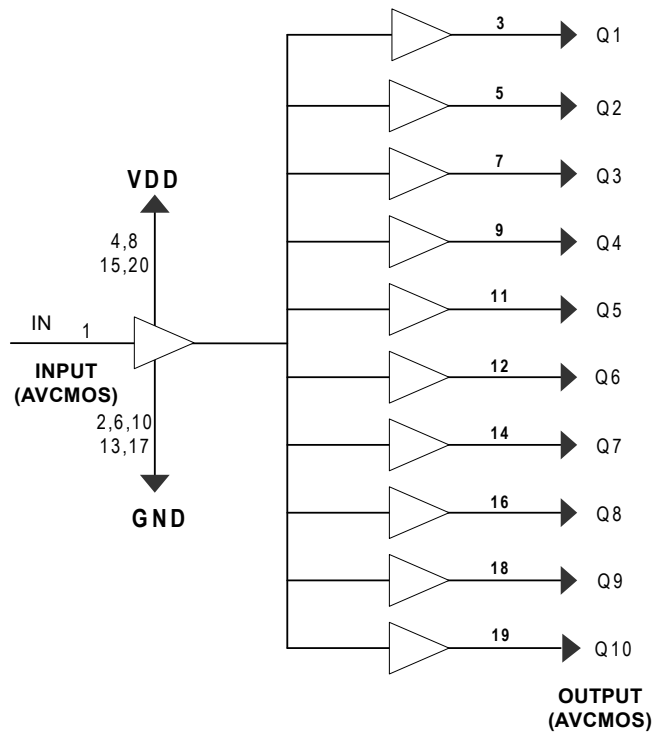

## Contents

|  |          |  |           |
|--|----------|--|-----------|
| <b>Pin Configuration</b> .....             | <b>3</b> | <b>Parameter Measurement Information:</b>            |           |
| <b>Pin Description</b> .....               | <b>3</b> | <b>VDD at 8 V</b> .....                              | <b>9</b>  |
| <b>Maximum Ratings</b> .....               | <b>4</b> | <b>Ordering Information</b> .....                    | <b>10</b> |
| <b>DC Electrical Characteristics</b> ..... | <b>4</b> | Ordering Code Definitions .....                      | 10        |
| <b>DC Electrical Characteristics</b> ..... | <b>4</b> | <b>Package Diagram</b> .....                         | <b>11</b> |
| <b>DC Electrical Characteristics</b> ..... | <b>5</b> | <b>Acronyms</b> .....                                | <b>12</b> |
| <b>Capacitance</b> .....                   | <b>5</b> | <b>Document Conventions</b> .....                    | <b>12</b> |
| <b>Thermal Resistance</b> .....            | <b>5</b> | Units of Measure .....                               | 12        |
| <b>Power Supply Characteristics</b> .....  | <b>5</b> | <b>Document History Page</b> .....                   | <b>13</b> |
| <b>High Frequency Parametrics</b> .....    | <b>6</b> | <b>Sales, Solutions, and Legal Information</b> ..... | <b>14</b> |
| <b>AC Switching Characteristics</b> .....  | <b>7</b> | Worldwide Sales and Design Support .....             | 14        |
| <b>AC Switching Characteristics</b> .....  | <b>7</b> | Products .....                                       | 14        |
| <b>AC Switching Characteristics</b> .....  | <b>7</b> | PSoC® Solutions .....                                | 14        |
| <b>Parameter Measurement Information:</b>  |          | Cypress Developer Community .....                    | 14        |
| <b>VDD at 3.3 V to 2.5 V</b> .....         | <b>8</b> | Technical Support .....                              | 14        |

## Pin Configuration

Figure 1. 20-pin SOIP/SSOP pinout

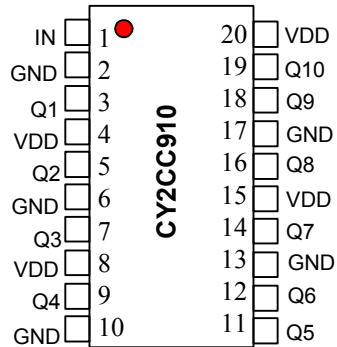

20 pin SOIC/SSOP

## Pin Description

| Pin Number                         | Pin Name                                | Description  |
|------------------------------------|---|--------------|
| 1                                  | IN                                      | Input        |
| 2, 6, 10, 13, 17                   | GND                                     | Ground       |
| 4, 8, 15, 20                       | V <sub>DD</sub>                         | Power Supply |
| 3, 5, 7, 9, 11, 12, 14, 16, 18, 19 | Q1, Q2, Q3, Q4, Q5, Q6, Q7, Q8, Q9, Q10 | Output       |

## Maximum Ratings

Exceeding maximum ratings<sup>[1]</sup> may shorten the useful life of the device. User guidelines are not tested.

Storage temperature: ..... -65° C to +150° C  
 Ambient temperature: ..... -40° C to +85° C  
 Supply voltage to ground potential

$V_{CC}$  ..... -0.5 V to 4.6 V  
 Input ..... -0.5 V to 5.8 V  
 Supply voltage to ground potential  
 (Outputs only) ..... -0.5 V to  $V_{DD} + 1$  V  
 DC output voltage ..... -0.5 V to  $V_{DD} + 1$  V  
 Power dissipation ..... 0.75 W

## DC Electrical Characteristics

At 3.3 V (See Figure 2)

| Parameter | Description              | Conditions  | Min | Typ  | Max  | Unit          |
|-----------|--------------------------|---|-----|------|------|---------------|
| $V_{OH}$  | Output high voltage      | $V_{DD} = \text{Min}, V_{IN} = V_{IH}$ or $V_{IL}$<br>$I_{OH} = -12$ mA | 2.3 | –    | –    | V             |
| $V_{OL}$  | Output low voltage       | $V_{DD} = \text{Min}, V_{IN} = V_{IH}$ or $V_{IL}$<br>$I_{OL} = 12$ mA  | –   | –    | 0.5  | V             |
| $V_{IH}$  | Input high voltage       | Guaranteed Logic High Level   | 2   | –    | 5.8  | V             |
| $V_{IL}$  | Input low voltage        | Guaranteed Logic Low Level  | –   | –    | 0.8  | V             |
| $I_{IH}$  | Input high current       | $V_{DD} = \text{Max}$<br>$V_{IN} = 2.7$ V                               | –   | –    | 1    | $\mu\text{A}$ |
| $I_{IL}$  | Input low current        | $V_{DD} = \text{Max}$<br>$V_{IN} = 0.5$ V                               | –   | –    | -1   | $\mu\text{A}$ |
| $I_I$     | Input high current       | $V_{DD} = \text{Max}, V_{IN} = V_{DD}(\text{Max})$                      | –   | –    | 20   | $\mu\text{A}$ |
| $V_{IK}$  | Clamp diode voltage      | $V_{DD} = \text{Min}, I_{IN} = -18$ mA                                  | –   | -0.7 | -1.2 | V             |
| $I_{OK}$  | Continuous clamp current | $V_{DD} = \text{Max}, V_{OUT} = \text{GND}$                             | –   | –    | -50  | mA            |
| $O_{OFF}$ | Power-down disable       | $V_{DD} = \text{GND}, V_{OUT} = < 4.5$ V                                | –   | –    | 100  | $\mu\text{A}$ |
| $V_H$     | Input hysteresis         |   | –   | 80   | –    | mV            |

## DC Electrical Characteristics

At 2.5 V (See Figure 2)

| Parameter | Description              | Conditions   | Min | Typ  | Max  | Unit          |
|-----------|--------------------------|--|-----|------|------|---------------|
| $V_{OH}$  | Output high voltage      | $V_{DD} = \text{Min}, V_{IN} = V_{IH}$ or $V_{IL}$<br>$I_{OH} = -7$ mA | 1.8 | –    | –    | V             |
|           |                          | $I_{OH} = 12$ mA   | 1.6 | –    | –    | V             |
| $V_{OL}$  | Output low voltage       | $V_{DD} = \text{Min}, V_{IN} = V_{IH}$ or $V_{IL}$<br>$I_{OL} = 12$ mA |     | –    | 0.65 | V             |
| $V_{IH}$  | Input high voltage       | Guaranteed Logic High Level  | 1.6 | –    | 5.0  | V             |
| $V_{IL}$  | Input low voltage        | Guaranteed Logic Low Level   | –   | –    | 0.8  | V             |
| $I_{IH}$  | Input high current       | $V_{DD} = \text{Max}$<br>$V_{IN} = 2.4$ V                              | –   | –    | 1    | $\mu\text{A}$ |
| $I_{IL}$  | Input low current        | $V_{DD} = \text{Max}$<br>$V_{IN} = 0.5$ V                              | –   | –    | -1   | $\mu\text{A}$ |
| $I_I$     | Input high current       | $V_{DD} = \text{Max}, V_{IN} = V_{DD}(\text{Max})$                     | –   | –    | 20   | $\mu\text{A}$ |
| $V_{IK}$  | Clamp diode voltage      | $V_{DD} = \text{Min}, I_{IN} = -18$ mA                                 | –   | -0.7 | -1.2 | V             |
| $I_{OK}$  | Continuous clamp current | $V_{DD} = \text{Max}, V_{OUT} = \text{GND}$                            | –   | –    | -50  | mA            |
| $O_{OFF}$ | Power down disable       | $V_{DD} = \text{GND}, V_{OUT} = < 4.5$ V                               | –   | –    | 100  | $\mu\text{A}$ |
| $V_H$     | Input hysteresis         |  | –   | 80   | –    | mV            |

### Note

1. Stresses greater than those listed under absolute maximum ratings may cause permanent damage to the device. This is intended to be a stress rating only and functional operation of the device at these or any other conditions above those indicated in the operation sections of this specification is not implied. Exposure to absolute maximum rating conditions for extended periods may affect reliability.

## DC Electrical Characteristics

At 1.8 V (See [Figure 6](#))

| Parameter       | Description         | Test Condition <sup>[2]</sup> | Min                          | Max                          | Unit |
|-----------------|---------------------|-------------------------------|------------------------------|------------------------------|------|
| V <sub>DD</sub> | Supply voltage      |                               | 1.71                         | 1.89                         | V    |
| V <sub>IH</sub> | Input high voltage  |                               | 0.65 × V <sub>DD</sub> [1.1] | 4.3                          | V    |
| V <sub>IL</sub> | Input low voltage   |                               | -0.3                         | 0.35 × V <sub>DD</sub> [0.6] | V    |
| V <sub>OH</sub> | Output high voltage | I <sub>OH</sub> = -2 mA       | V <sub>DD</sub> - 0.45 [1.2] | -                            | V    |
| V <sub>OL</sub> | Output low voltage  | I <sub>OH</sub> = 2 mA        | -                            | 0.45                         | V    |

## Capacitance

| Parameter <sup>[3]</sup> | Description        | Test Conditions        | Typ | Max | Unit |
|--------------------------|--------------------|------------------------|-----|-----|------|
| C <sub>IN</sub>          | Input capacitance  | V <sub>IN</sub> = 0 V  | 2.5 | -   | pF   |
| C <sub>OUT</sub>         | Output capacitance | V <sub>OUT</sub> = 0 V | 6.5 | -   | pF   |

## Thermal Resistance

| Parameter <sup>[3]</sup> | Description                              | Test Conditions   | 20-pin SSOP | Unit |
|--------------------------|--|---|-------------|------|
| θ <sub>JA</sub>          | Thermal resistance (junction to ambient) | Test conditions follow standard test methods and procedures for measuring thermal impedance, in accordance with EIA/JESD51. | 79          | °C/W |
| θ <sub>JC</sub>          | Thermal resistance (junction to case)    |   | 35          | °C/W |

## Power Supply Characteristics

(See [Figure 2](#))

| Parameter        | Description  | Test Conditions  | Min | Typ | Max  | Unit       |
|------------------|--|--|-----|-----|------|------------|
| ΔI <sub>CC</sub> | Delta I <sub>CC</sub> Quiescent Power Supply Current | (I <sub>DD</sub> @ V <sub>DD</sub> = Max and V <sub>IN</sub> = V <sub>DD</sub> ) - (I <sub>DD</sub> @ V <sub>DD</sub> = Max and V <sub>IN</sub> = V <sub>DD</sub> - 0.6 V 6 V) | -   | -   | 50   | μA         |
| I <sub>CCD</sub> | Dynamic power supply current                         | V <sub>DD</sub> = Max<br>Input toggling 50% Duty Cycle,<br>Outputs Open  | -   | -   | 0.63 | mA/<br>MHz |
| I <sub>C</sub>   | Total power supply current                           | V <sub>DD</sub> = Max<br>Input toggling 50% Duty Cycle,<br>Outputs Open, f <sub>L</sub> = 40 MHz   | -   | -   | 25   | mA         |

### Notes

2. Test load conditions: 500-Ohm to ground with approximately 6-pF total loading and 200-MHz maximum frequency.
3. These parameters are guaranteed by design and are not tested.

## High Frequency Parametrics

| Parameter          | Description                           | Test Conditions  | Min                          | Typ | Max | Unit       |
|--------------------|---------------------------------------|--|------------------------------|-----|-----|------------|
| $D_J$              | Jitter, Deterministic                 | 50% duty cycle<br>$t_W(50-50)$<br>The "point to point load circuit"<br>  Output Jitter – Input Jitter                    | See <a href="#">Figure 4</a> | –   | –   | 20<br>ps   |
| $F_{max}$<br>3.3 V | Maximum frequency<br>$V_{DD} = 3.3$ V | 50% duty cycle<br>$t_W(50-50)$<br>Standard Load Circuit.   | See <a href="#">Figure 2</a> | –   | –   | 160<br>MHz |
|                    |                                       | 50% duty cycle<br>$t_W(50-50)$<br>The "point to point load circuit"  | See <a href="#">Figure 4</a> | –   | –   | 650        |
| $F_{max}$<br>2.5 V | Maximum frequency<br>$V_{DD} = 2.5$ V | The "point-to-point load circuit"<br>$V_{IN} = 2.4$ V/0.0 V<br>$V_{OUT} = 1.7$ V/0.7 V                                   | See <a href="#">Figure 4</a> | –   | –   | 200<br>MHz |
| $F_{max}$<br>1.8 V | Maximum frequency<br>$V_{DD} = 1.8$ V | The "6-pF load circuit"<br>$V_{IN} = 1.7$ V/0.0 V<br>$V_{OUT} = 1.2$ V/0.4 V   | See <a href="#">Figure 6</a> | –   | –   | 200<br>MHz |
| $F_{max(20)}$      | Maximum frequency<br>$V_{DD} = 3.3$ V | 20% duty cycle<br>$t_W(20-80)$<br>The "point to point load circuit"<br>$V_{IN} = 3.0$ V/0.0 V<br>$V_{OUT} = 2.3$ V/0.4 V | See <a href="#">Figure 5</a> | –   | –   | 250<br>MHz |
| $t_W$<br>3.3 V     | Minimum pulse<br>$V_{DD} = 3.3$ V     | The "point-to-point load circuit"<br>$V_{IN} = 3.0$ V/0.0 V<br>F = 100 MHz<br>$V_{OUT} = 2.0$ V/0.8 V                    | See <a href="#">Figure 4</a> | 1   | –   | –<br>ns    |
| $t_W$<br>2.5 V     | Minimum pulse<br>$V_{DD} = 2.5$ V     | The "point-to-point load circuit"<br>$V_{IN} = 2.4$ V/0.0 V<br>F = 100 MHz<br>$V_{OUT} = 1.7$ V/0.7 V                    | See <a href="#">Figure 4</a> | 1   | –   | –<br>ns    |
| $t_W$<br>1.8 V     | Minimum pulse<br>$V_{DD} = 1.8$ V     | The "6-pF load circuit"<br>$V_{IN} = 1.7$ V/0.0 V<br>$V_{OUT} = 1.2$ V/0.4 V   | See <a href="#">Figure 6</a> | 1   | –   | –<br>ns    |

## AC Switching Characteristics

At 3.3 V ( $V_{DD} = 3.3 \text{ V} \pm 5\%$ , Temperature =  $-40 \text{ }^\circ\text{C}$  to  $+85 \text{ }^\circ\text{C}$ )

| Parameter   | Description  |                               | Min | Typ | Max | Unit |
|-------------|--|-------------------------------|-----|-----|-----|------|
| $t_{PLH}$   | Propagation delay – Low to High  | See <a href="#">Figure 3</a>  | 1.5 | 2.7 | 3.5 | ns   |
| $t_{PHL}$   | Propagation delay – High to Low  |                               | 1.5 | 2.7 | 3.5 | ns   |
| $t_R$       | Output rise time   |                               | –   | 0.8 | –   | V/ns |
| $t_F$       | Output fall time   |                               | –   | 0.8 | –   | V/ns |
| $t_{SK(0)}$ | Output Skew: Skew between outputs of the same package (in phase).  | See <a href="#">Figure 10</a> | –   | –   | 0.2 | ns   |
| $t_{SK(p)}$ | Pulse Skew: Skew between opposite transitions of the same output ( $t_{PHL} - t_{PLH}$ ).                                | See <a href="#">Figure 9</a>  | –   | –   | 0.2 | ns   |
| $t_{SK(t)}$ | Package Skew: Skew between outputs of different packages at the same power supply voltage, temperature and package type. | See <a href="#">Figure 11</a> | –   | –   | 0.4 | ns   |

## AC Switching Characteristics

At 2.5 V ( $V_{DD} = 2.5 \text{ V} \pm 5\%$ , Temperature =  $-40 \text{ }^\circ\text{C}$  to  $+85 \text{ }^\circ\text{C}$ )

| Parameter   | Description  |                               | Min | Typ | Max | Unit |
|-------------|--|-------------------------------|-----|-----|-----|------|
| $t_{PLH}$   | Propagation delay – Low to High  | See <a href="#">Figure 3</a>  | 1.5 | 2.7 | 3.5 | ns   |
| $t_{PHL}$   | Propagation delay – High to Low  |                               | 1.5 | 2.7 | 3.5 | ns   |
| $t_R$       | Output rise time   |                               | –   | 0.8 | –   | V/ns |
| $t_F$       | Output fall time   |                               | –   | 0.8 | –   | V/ns |
| $t_{SK(0)}$ | Output Skew: Skew between outputs of the same package (in phase).  | See <a href="#">Figure 10</a> | –   | –   | 0.2 | ns   |
| $t_{SK(p)}$ | Pulse Skew: Skew between opposite transitions of the same output ( $t_{PHL} - t_{PLH}$ ).                                | See <a href="#">Figure 9</a>  | –   | –   | 0.2 | ns   |
| $t_{SK(t)}$ | Package Skew: Skew between outputs of different packages at the same power supply voltage, temperature and package type. | See <a href="#">Figure 11</a> | –   | –   | 0.4 | ns   |

## AC Switching Characteristics

At 1.8 V ( $V_{DD} = 1.8 \text{ V} \pm 5\%$ , Temperature =  $-40 \text{ }^\circ\text{C}$  to  $+85 \text{ }^\circ\text{C}$ )

| Parameter   | Description  |                               | Min | Typ | Max | Unit |
|-------------|--|-------------------------------|-----|-----|-----|------|
| $t_{PLH}$   | Propagation delay – Low to High  | See <a href="#">Figure 7</a>  | 1.5 | 2.7 | 3.5 | ns   |
| $t_{PHL}$   | Propagation delay – High to Low  |                               | 1.5 | 2.7 | 3.5 | ns   |
| $t_R$       | Output rise time 20%–80%   |                               | 0.2 | –   | 1.5 | ns   |
| $t_F$       | Output fall time 20%–80%   |                               | 0.2 | –   | 1.5 | ns   |
| $t_{SK(0)}$ | Output Skew: Skew between outputs of the same package (in phase).  | See <a href="#">Figure 10</a> | –   | –   | 0.2 | ns   |
| $t_{SK(p)}$ | Pulse Skew: Skew between opposite transitions of the same output ( $t_{PHL} - t_{PLH}$ ).                                | See <a href="#">Figure 9</a>  | –   | –   | 0.2 | ns   |
| $t_{SK(t)}$ | Package Skew: Skew between outputs of different packages at the same power supply voltage, temperature and package type. | See <a href="#">Figure 11</a> | –   | –   | 0.4 | ns   |

**Parameter Measurement Information:  $V_{DD}$  at 3.3 V to 2.5 V**

**Figure 2. Load Circuit** [4, 5, 6]

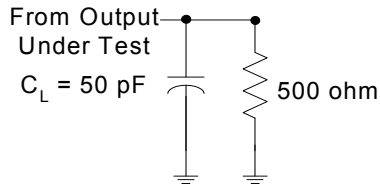

**Figure 3. Voltage Waveforms Propagation Delay Times** [7]

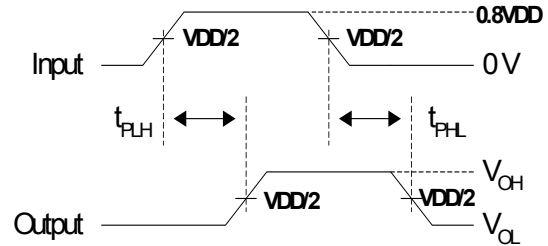

**Figure 4. Point to Point Load Circuit** [4, 5, 6]

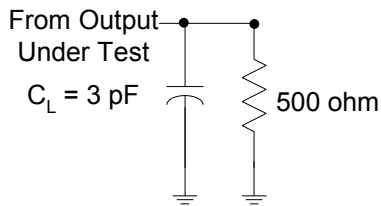

**Figure 5. Voltage Waveforms – Pulse Duration** [5]

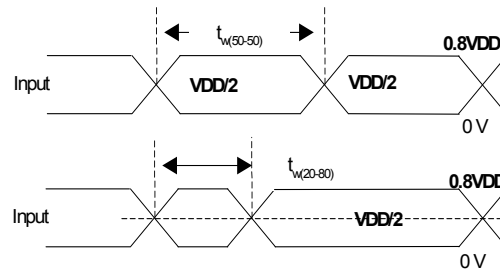

**Notes**

4.  $C_L$  includes probe and jig capacitance.
5. All input pulses are supplied by generators having the following characteristics: PRR < 100 MHz,  $Z_0 = 50\Omega$ ,  $t_r < 2.5 \text{ ns}$ ,  $t_f < 2.5 \text{ ns}$ .
6. The outputs are measured one at a time with one transition per measurement.
7.  $T_{PLH}$  and  $T_{PHL}$  are the same as  $t_{pd}$ .

**Parameter Measurement Information: V<sub>DD</sub> at 8 V**

**Figure 6. Load Circuit** [8, 9, 10]

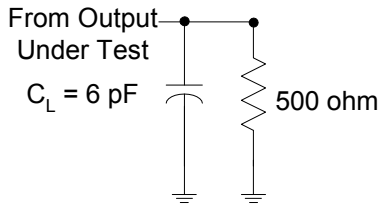

**Figure 7. Voltage Waveforms Propagation**

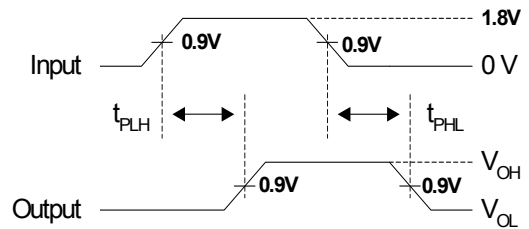

**Figure 8. Voltage Waveforms – Pulse Duration** [9]

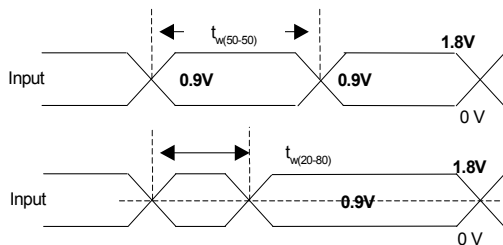

**Figure 9. Pulse Skew - tsk<sub>(p)</sub>**

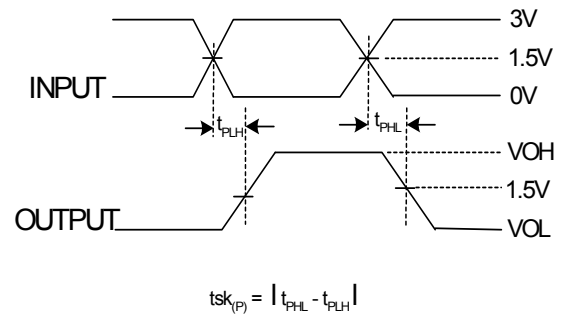

**Figure 10. Output Skew - tsk<sub>(o)</sub>**

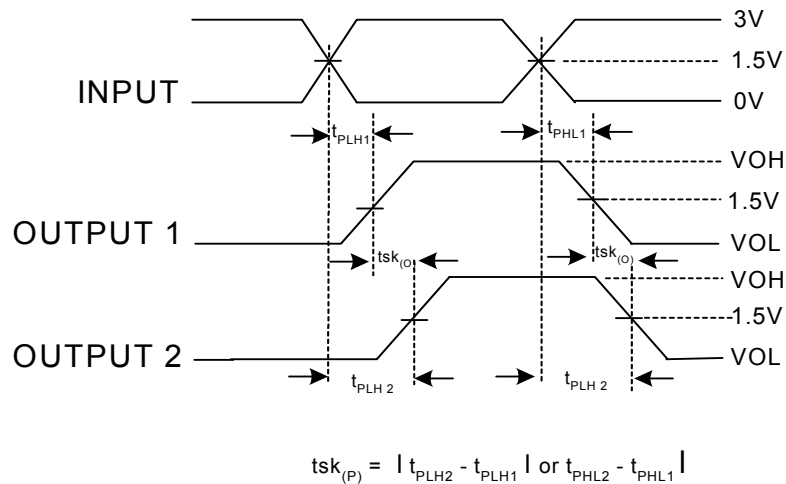

**Notes**

- 8. C<sub>L</sub> includes probe and jig capacitance.
- 9. All input pulses are supplied by generators having the following characteristics: PRR < 100 MHz, Z<sub>0</sub> = 50Ω, t<sub>R</sub> < 2.5 ns, t<sub>F</sub> < 2.5 ns.
- 10. The outputs are measured one at a time with one transition per measurement.



Package Diagram

Figure 12. 20-pin SSOP (210 Mils) O20.21 Package Outline, 51-85077

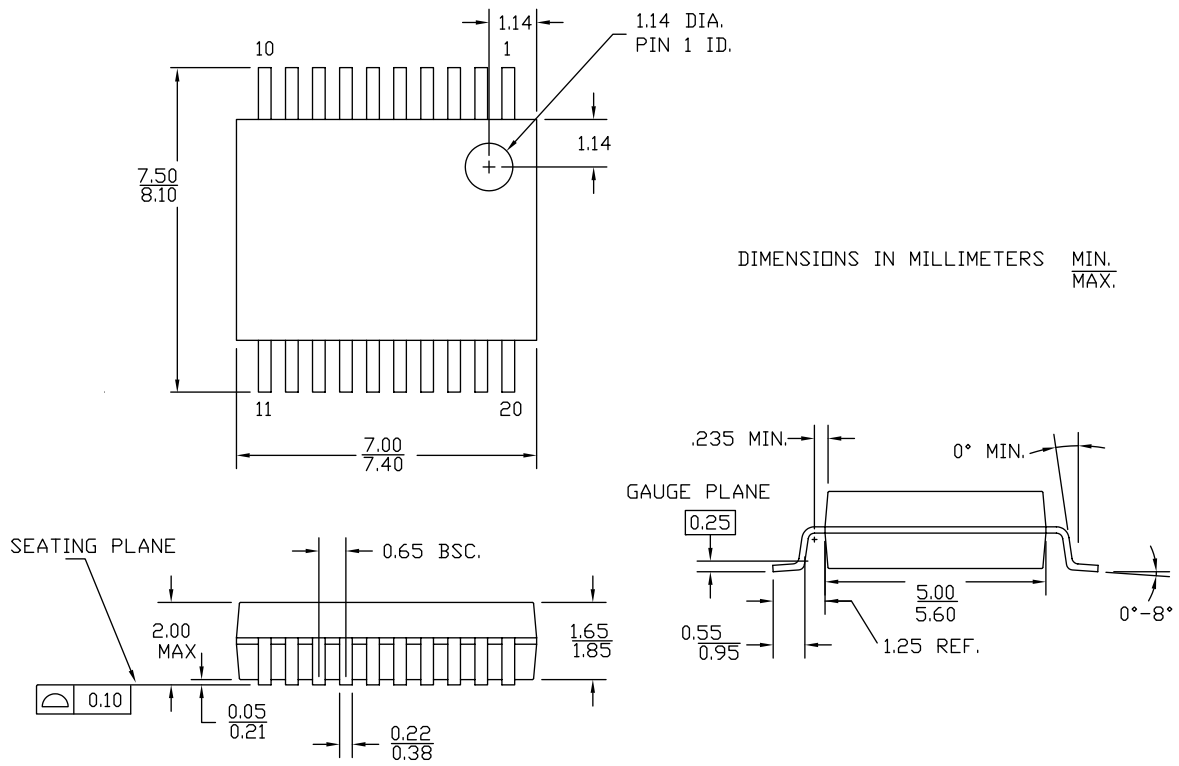

51-85077 \*F

## Acronyms

| Acronym | Description                             |
|---------|---|
| CMOS    | complementary metal oxide semiconductor |
| DJ      | deterministic jitter                    |
| SSOP    | shrunk small outline package            |

## Document Conventions

### Units of Measure

| Symbol | Unit of Measure |
|--------|-----------------|
| °C     | degree Celsius  |
| MHZ    | megahertz       |
| uA     | microamperes    |
| mA     | milliamperes    |
| ms     | milliseconds    |
| ns     | nanoseconds     |
| %      | percent         |
| pF     | picofarads      |
| ps     | picoseconds     |
| V      | volt            |

## Document History Page

| Document Title: CY2CC910, 1:10 Clock Fanout Buffer<br>Document No: 38-07348 |         |                 |                 |  |
|---|---------|-----------------|-----------------|--|
| Rev.  | ECN No. | Orig. of Change | Submission Date | Description of Change  |
| **  | 114318  | TSM             | 05/10/02        | New data sheet   |
| *A  | 119148  | RGL             | 10/07/02        | Added 5.8 as the Max value for $V_{IH}$ in the DC Electrical Characteristics @3.3 V table.<br>Changed the Max value of $V_{IH}$ from 5.8 to 5.0 in the DC Electrical Characteristics @2.5 V table.<br>Changed the value of $V_{IH}$ from $V_{DD}+0.3$ [2.25] to 4.3 in the DC Electrical Characteristics @1.8 V table.   |
| *B  | 404287  | RGL             | See ECN         | Added Lead-free devices for SSOP   |
| *C  | 2595534 | CXQ / PYRS      | 10/23/08        | Added "Status" column to Ordering Information table<br>Updated Package Diagram 51-85024<br>Updated to new template.  |
| *D  | 2896073 | CXQ             | 03/19/10        | Removed SOIC packages related information in all instances across the document.<br>Updated <a href="#">Ordering Information</a> :<br>Removed obsolete parts from ordering information table and added CY2CC910OXI-1, CY2CC910OXI-1T.<br>Updated <a href="#">Package Diagram</a> .  |
| *E  | 3056154 | CXQ             | 10/08/2010      | Updated <a href="#">Ordering Information</a> :<br>Removed CY2CC910OXI-1, CY2CC910OXI-1T, CY2CC910OXC, and CY2CC910OXCT parts.<br>Removed the Note "Devices with part numbers ending with -1 are identical to devices without the -1 suffix. There are no differences in specification." and its reference.   |
| *F  | 3411742 | PURU            | 10/18/2011      | Added <a href="#">Contents</a> .<br>Updated <a href="#">Functional Description</a> :<br>Removed "Cypress employs the unique AVCMOS type outputs VOI (Variable Output Impedance) that dynamically adjust for variable impedance matching, eliminate the need for series damping resistors, and reduce overall noise."<br>Removed "Variable Output Impedance Control (VOI)".<br>Updated <a href="#">Ordering Information</a><br>Updated <a href="#">Package Diagram</a> .<br>Added <a href="#">Acronyms</a> and <a href="#">Units of Measure</a> . |
| *G  | 4575136 | TAVA            | 11/20/2014      | Updated <a href="#">Functional Description</a> :<br>Added "For a complete list of related resources, <a href="#">click here</a> ." at the end.<br>Updated to new template.<br>Completing Sunset Review.  |
| *H  | 4586288 | TAVA            | 12/03/2014      | Updated <a href="#">Functional Description</a> :<br>Replaced "resources" with "documentation".   |
| *I  | 5272946 | PSR             | 05/16/2016      | Added <a href="#">Thermal Resistance</a> .<br>Updated <a href="#">Package Diagram</a> :<br>spec 51-85077 – Changed revision from *E to *F.<br>Updated to new template.   |
| *J  | 5726314 | PSR             | 05/11/2017      | Updated <a href="#">DC Electrical Characteristics</a> (At 3.3 V):<br>Removed typical values of $V_{OH}$ and $V_{OL}$ parameters.<br>Updated to new template.   |

## Sales, Solutions, and Legal Information

### Worldwide Sales and Design Support

Cypress maintains a worldwide network of offices, solution centers, manufacturer's representatives, and distributors. To find the office closest to you, visit us at [Cypress Locations](#).

#### Products

|                               |  |
|-------------------------------|--|
| ARM® Cortex® Microcontrollers | <a href="http://cypress.com/arm">cypress.com/arm</a>               |
| Automotive                    | <a href="http://cypress.com/automotive">cypress.com/automotive</a> |
| Clocks & Buffers              | <a href="http://cypress.com/clocks">cypress.com/clocks</a>         |
| Interface                     | <a href="http://cypress.com/interface">cypress.com/interface</a>   |
| Internet of Things            | <a href="http://cypress.com/iot">cypress.com/iot</a>               |
| Memory                        | <a href="http://cypress.com/memory">cypress.com/memory</a>         |
| Microcontrollers              | <a href="http://cypress.com/mcu">cypress.com/mcu</a>               |
| PSoC                          | <a href="http://cypress.com/psoc">cypress.com/psoc</a>             |
| Power Management ICs          | <a href="http://cypress.com/pmic">cypress.com/pmic</a>             |
| Touch Sensing                 | <a href="http://cypress.com/touch">cypress.com/touch</a>           |
| USB Controllers               | <a href="http://cypress.com/usb">cypress.com/usb</a>               |
| Wireless Connectivity         | <a href="http://cypress.com/wireless">cypress.com/wireless</a>     |

#### PSoC® Solutions

[PSoC 1](#) | [PSoC 3](#) | [PSoC 4](#) | [PSoC 5LP](#)

#### Cypress Developer Community

[Forums](#) | [WICED IOT Forums](#) | [Projects](#) | [Video](#) | [Blogs](#) | [Training](#) | [Components](#)

#### Technical Support

[cypress.com/support](http://cypress.com/support)



© Cypress Semiconductor Corporation, 2002–2017. This document is the property of Cypress Semiconductor Corporation and its subsidiaries, including Spansion LLC ("Cypress"). This document, including any software or firmware included or referenced in this document ("Software"), is owned by Cypress under the intellectual property laws and treaties of the United States and other countries worldwide. Cypress reserves all rights under such laws and treaties and does not, except as specifically stated in this paragraph, grant any license under its patents, copyrights, trademarks, or other intellectual property rights. If the Software is not accompanied by a license agreement and you do not otherwise have a written agreement with Cypress governing the use of the Software, then Cypress hereby grants you a personal, non-exclusive, nontransferable license (without the right to sublicense) (1) under its copyright rights in the Software (a) for Software provided in source code form, to modify and reproduce the Software solely for use with Cypress hardware products, only internally within your organization, and (b) to distribute the Software in binary code form externally to end users (either directly or indirectly through resellers and distributors), solely for use on Cypress hardware product units, and (2) under those claims of Cypress's patents that are infringed by the Software (as provided by Cypress, unmodified) to make, use, distribute, and import the Software solely for use with Cypress hardware products. Any other use, reproduction, modification, translation, or compilation of the Software is prohibited.

TO THE EXTENT PERMITTED BY APPLICABLE LAW, CYPRESS MAKES NO WARRANTY OF ANY KIND, EXPRESS OR IMPLIED, WITH REGARD TO THIS DOCUMENT OR ANY SOFTWARE OR ACCOMPANYING HARDWARE, INCLUDING, BUT NOT LIMITED TO, THE IMPLIED WARRANTIES OF MERCHANTABILITY AND FITNESS FOR A PARTICULAR PURPOSE. To the extent permitted by applicable law, Cypress reserves the right to make changes to this document without further notice. Cypress does not assume any liability arising out of the application or use of any product or circuit described in this document. Any information provided in this document, including any sample design information or programming code, is provided only for reference purposes. It is the responsibility of the user of this document to properly design, program, and test the functionality and safety of any application made of this information and any resulting product. Cypress products are not designed, intended, or authorized for use as critical components in systems designed or intended for the operation of weapons, weapons systems, nuclear installations, life-support devices or systems, other medical devices or systems (including resuscitation equipment and surgical implants), pollution control or hazardous substances management, or other uses where the failure of the device or system could cause personal injury, death, or property damage ("Unintended Uses"). A critical component is any component of a device or system whose failure to perform can be reasonably expected to cause the failure of the device or system, or to affect its safety or effectiveness. Cypress is not liable, in whole or in part, and you shall and hereby do release Cypress from any claim, damage, or other liability arising from or related to all Unintended Uses of Cypress products. You shall indemnify and hold Cypress harmless from and against all claims, costs, damages, and other liabilities, including claims for personal injury or death, arising from or related to any Unintended Uses of Cypress products.

Cypress, the Cypress logo, Spansion, the Spansion logo, and combinations thereof, WICED, PSoC, CapSense, EZ-USB, F-RAM, and Traveo are trademarks or registered trademarks of Cypress in the United States and other countries. For a more complete list of Cypress trademarks, visit [cypress.com](http://cypress.com). Other names and brands may be claimed as property of their respective owners.

## Looking for pricing, stock, or lifecycle information?

Click below to explore more details on WIN SOURCE:

-  [View CY2CC9100XI on WIN SOURCE](#)
-  [Cypress Semiconductor Corp](#) Information

## Optimize Your Supply Chain with WIN SOURCE Solutions

-  Global Sourcing Solution
-  Obsolete Management
-  Cost Control Management
-  Shortage Management
-  Alternative Solution
-  Excess Inventory Management