



**THE DATASHEET OF  
AVA-183A+**





WIDEBAND, MICROWAVE

# Monolithic Amplifier

## AVA-183A+

50Ω 5 to 18 GHz

### THE BIG DEAL

- Surface Mount Amplifier up to 18 GHz
- Integrated DC blocks, Bias-Tee & Microwave bypass capacitor
- Superior Value
- Suitable for low phase noise applications
- Gain, 13.8 dB typ. & Flatness, ±1.2 dB
- Output Power, up to +19.0 dBm typ.
- Excellent isolation, 36 dB typ. at 12 GHz
- Single Positive Supply Voltage, +5V
- Unconditionally Stable
- Aqueous washable; 3mm x 3mm SMT package

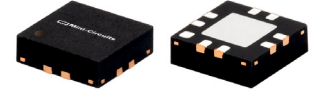

Generic photo used for illustration purposes only

CASE STYLE: DQ849

**+RoHS Compliant**

The +Suffix identifies RoHS Compliance. See our website for methodologies and qualifications

### APPLICATIONS

- Military EW and Radar
- DBS
- Wideband Isolation amplifier
- Microwave point-to-point radios
- Satellite systems

### PRODUCT OVERVIEW

The AVA-183A+ is a surface mount, microwave amplifier fabricated using InGaAs PHEMT technology and is a fully integrated gain block up to 18 GHz. It is packaged in Mini-Circuits industry standard 3x3 mm MCLP package, which provides excellent RF and thermal performance. The AVA-183A+ integrates the entire matching network with the majority of the bias circuit inside the package, reducing the need for complicated external circuits. This approach makes the AVA-183A+ extremely flexible and enables simple, straightforward use.

### KEY FEATURES

Feature	Advantages
Wideband, 5 to 18 GHz	Broad frequency range supports a wide array of applications from microwave radio and radar , to military communications and countermeasures.
Excellent Gain Flatness	Typical ±1.2 dB gain flatness across the entire frequency range minimizes the need for external equalizer networks making it a great fit for instrumentation and EW applications.
High Isolation	With reverse isolation of 31-42 dB (17-23 dB directivity), the AVA-183A+ is an excellent choice for buffering broadband circuits. It is an ideal LO driver amplifier and provides designers system flexibility and margin when integrating cascaded RF components.
Single +5V Supply	No hassle associated with amplifiers using dual supply; such as power supply sequencing. Integrated output bias-tee, simplifies layout & reduces cost.
Manufacturability	MSL1 and ESD Class1A (HBM) ratings minimize special handling on production lines.
Low additive phase noise, typically -151 dBc/Hz @10 KHz offset	Ideal for low phase noise synthesizer applications





**ELECTRICAL SPECIFICATIONS<sup>(1)</sup> AT 25°C, Z<sub>0</sub>=50Ω, (REFER TO CHARACTERIZATION CIRCUIT, FIG.1)**

Parameter	Condition (GHz)	Min.	Typ.	Max.	Units
Frequency Range		5.0		18.0	GHz
DC Voltage (V <sub>D1</sub> , V <sub>D2</sub> )			5.0		V
DC Current (I <sub>D1</sub> +I <sub>D2</sub> )		104	131	166	mA
Gain	5.0	—	12.9	—	dB
	8.0	12.0	14.7	—	
	10.0	12.0	14.0	—	
	12.0	—	13.4	—	
	14.0	—	13.1	—	
	16.0	—	13.6	—	
Input Return Loss	5.0		10.4		dB
	8.0		17.0		
	10.0		11.0		
	12.0		11.0		
	14.0		11.0		
	16.0		11.0		
Output Return Loss	5.0		8.0		dB
	8.0		18.0		
	10.0		14.0		
	12.0		11.0		
	14.0		10.6		
	16.0		11.2		
Output IP3 <sup>(2)</sup>	5.0		32.2		dBm
	8.0		29.0		
	10.0		27.7		
	12.0		26.3		
	14.0		25.1		
	16.0		24.3		
Output Power @ 1 dB compression	5.0	—	17.6		dBm
	8.0	—	18.0		
	10.0	16.0	19.0		
	12.0	—	19.0		
	14.0	—	19.9		
	16.0	—	19.6		
Noise Figure	5.0		7.4		dB
	8.0		4.3		
	10.0		4.5		
	12.0		4.8		
	14.0		5.1		
	16.0		5.1		
Additive Phase Noise 5.0 GHz, 10KHz offset	5.0		6.0		dBc/Hz
	8.0		-151		
	10.0		-151		
	12.0		-151		
	14.0		-151		
	16.0		-151		
Directivity (Isolation-Gain)	12		23.1		dB
DC Current Variation vs. Temperature <sup>(3)</sup>			0.046		mA/°C
Thermal Resistance			61		°C/W

**MAXIMUM RATINGS<sup>(4)</sup>**

Parameter	Ratings
Operating Temperature <sup>(5)</sup>	-40°C to 85°C
Storage Temperature	-55°C to 100°C
Channel Temperature	150°C
DC Voltage (Pad 7,8)	+5.5 V
DC Voltage (Pads 2, 5)	+10 V
Power Dissipation	980 mW
DC Current (Pad 7+8)	180 mA
Input Power (CW)	+20 dBm

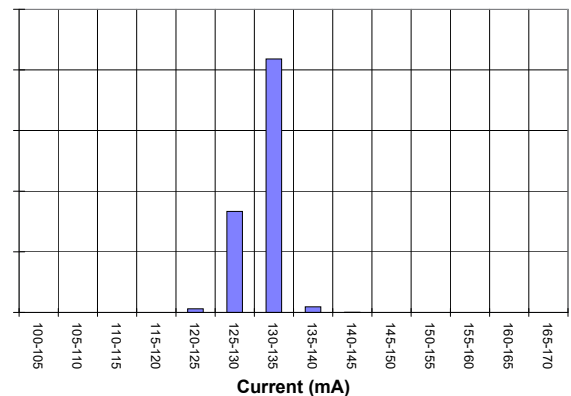

(1) Measured on Mini-Circuits Characterization test fixture TB-547-2+ See Characterization Test Circuit (Fig. 1)  
 (2) At Pout=9dBm/tone  
 (3) (Current at 85°C - Current at -45°C)/130  
 (4) Permanent damage may occur if any of these limits are exceeded. These maximum ratings are not intended for continuous normal operation.  
 (5) Defined with reference to ground pad temperature.



### INTERMODULATION AND IP3 VS. FREQUENCY AND OUTPUT POWER

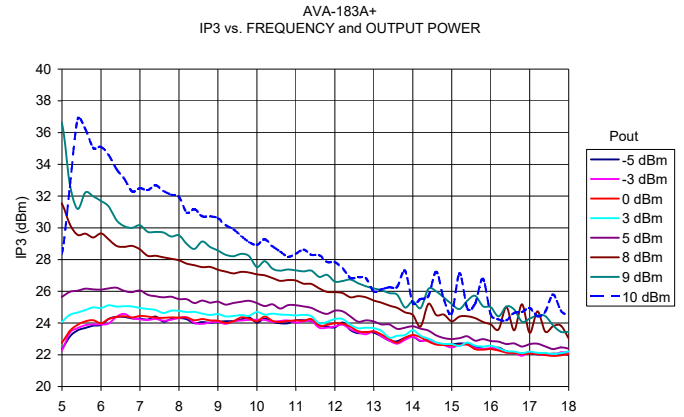
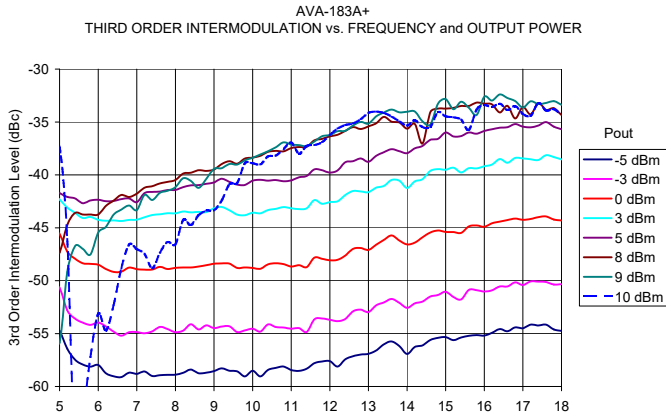

### SIMPLIFIED SCHEMATIC AND PAD DESCRIPTION

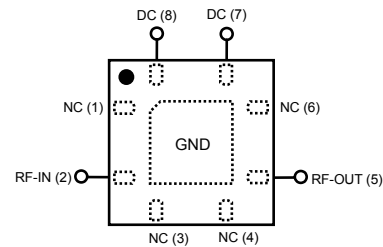
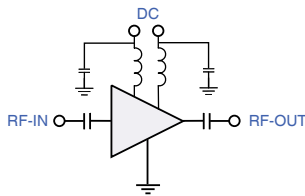

Function	Pad Number	Description (See Application Circuit, Fig. 2)
RF-IN	2	RF input pad
RF-OUT	5	RF output pad
DC	8( $V_{D1}$ ), 7( $V_{D2}$ )	DC power supply
GND	paddle in center of bottom	Connected to ground
NOT USED	1,3,4,6	No internal connection; recommended use: per PCB Layout PL-328



### CHARACTERIZATION TEST CIRCUIT

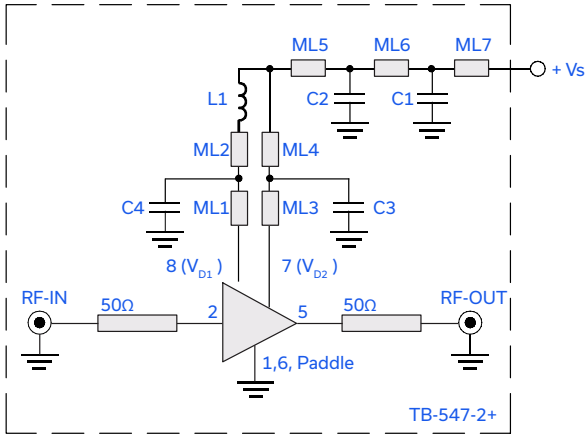

Fig 1. Block Diagram of Test Circuit used for characterization. (DUT soldered on Mini-Circuits Characterization Test Board TB-547-2+) Gain, Output power at 1dB compression (P1dB), Noise Figure, Output IP3 (OIP3) are measured using Agilent's N5242A PNA-X microwave network analyzer.

Conditions:

1. Gain: Pin=-25 dBm
2. Output IP3 (OIP3): Two tones, spaced 1 MHz apart, 9 dBm/tone at output.
3. Vs adjusted for 5.0V at device (VD1 and VD2), compensating loss of bias lines.

C1=5.6pF, 0402 (NPO)  
 C2=18pF, 0402 (NPO)  
 C3=0.001μF, 0402 (NPO)  
 C4=0.1 μF, 0402 (X7R)  
 L1=3.3nH, 0805 (wire wound)

ML1-ML7 are short microstrip lines  
 Refer to 98-PL-328

### RECOMMENDED APPLICATION CIRCUIT

(refer to evaluation board for PCB Layout and component values)

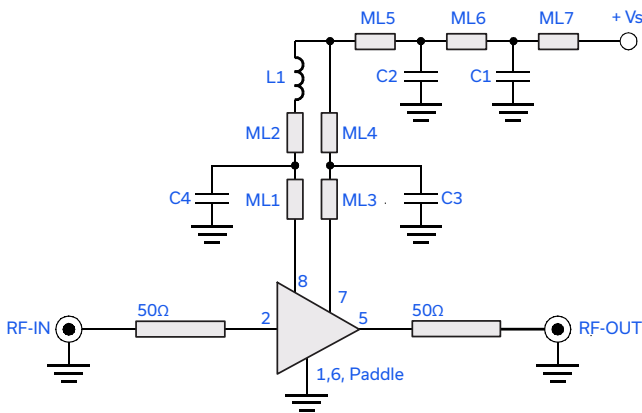
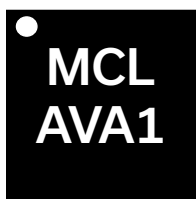

Fig 2. Recommended Application Circuit

C1=5.6pF, 0402 (NPO)  
 C2=18pF, 0402 (NPO)  
 C3=0.001μF, 0402 (NPO)  
 C4=0.1 μF, 0402 (X7R)  
 L1=3.3nH, 0805 (wire wound)

ML1-ML7 are short microstrip lines  
 Refer to 98-PL-328

### PRODUCT MARKING



- ← black body
- ← model family designation

Marking may contain other features or characters for internal lot control



ADDITIONAL DETAILED TECHNICAL INFORMATION IS AVAILABLE ON OUR DASH BOARD. TO ACCESS [CLICK HERE](#)

Performance Data	Data Table Swept Graphs S-Parameter (S2P Files) Data Set (.zip file)
Case Style	DQ849 Plastic package, exposed paddle, lead finish: Matte-tin
Tape & Reel Standard quantities available on reel	F104 7" reels with 20, 50, 100, 200, 500, 1000 or 2000 devices
Suggested Layout for PCB Design	PL-328
Evaluation Board	TB-547-2+
Environmental Ratings	ENV08T1

### ESD RATING

Human Body Model (HBM): 1A (250 to <500V) in accordance with ANSI/ESD STM 5.1 - 2001

Machine Model (MM): M1 (25V) in accordance with ANSI/ESD STM5.2-1999

### MSL RATING

Moisture Sensitivity: MSL1 in accordance with IPC/JEDEC J-STD-020D

### MSL TEST FLOW CHART

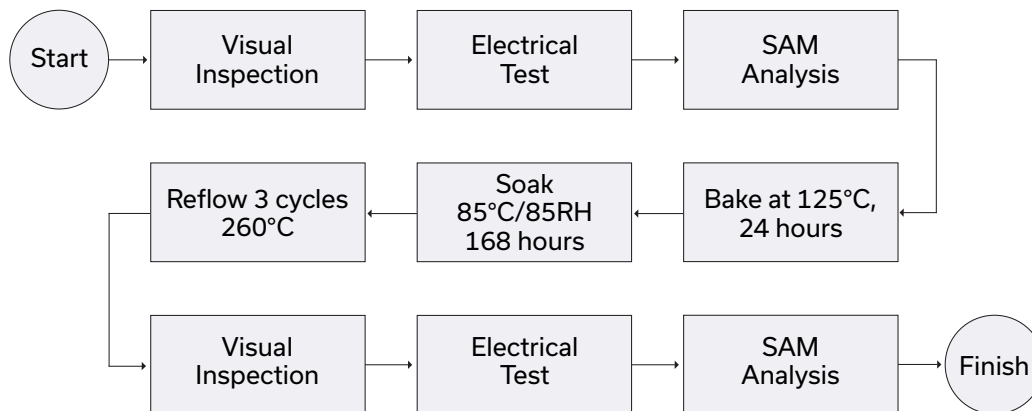

- NOTES**
- A. Performance and quality attributes and conditions not expressly stated in this specification document are intended to be excluded and do not form a part of this specification document.
  - B. Electrical specifications and performance data contained in this specification document are based on Mini-Circuit's applicable established test performance criteria and measurement instructions.
  - C. The parts covered by this specification document are subject to Mini-Circuits standard limited warranty and terms and conditions (collectively, "Standard Terms"); Purchasers of this part are entitled to the rights and benefits contained therein. For a full statement of the standard. Terms and the exclusive rights and remedies thereunder, please visit Mini-Circuits' website at [www.minicircuits.com/MCLStore/terms.jsp](http://www.minicircuits.com/MCLStore/terms.jsp)

## Looking for pricing, stock, or lifecycle information?

Click below to explore more details on WIN SOURCE:

 [View AVA-183A+](#) on WIN SOURCE

 [Mini-Circuits](#) Information

## Optimize Your Supply Chain with WIN SOURCE Solutions

-  Global Sourcing Solution
-  Obsolete Management
-  Cost Control Management
-  Shortage Management
-  Alternative Solution
-  Excess Inventory Management