



**THE DATASHEET OF
ADUC7032BSTZ-88**



FEATURES

High precision analog-to-digital converters (ADCs)

Dual channel, simultaneous sampling, 16-bit Σ - Δ ADCs

Third independent ADC for temperature sensing

Programmable ADC throughput from 1 Hz to 8 kHz

On-chip 5 ppm/ $^{\circ}$ C voltage reference

Current channel

Fully differential, buffered input

Programmable gain: 1 to 512

ADC input range: -200 mV to $+300$ mV

Digital comparators, with current accumulator feature

Voltage channel

Buffered, on-chip attenuator for 12 V battery inputs

Temperature channel

External and on-chip temperature sensor options

Microcontroller

ARM7TDMI core, 16-/32-bit RISC architecture

20.48 MHz PLL with programmable divider

PLL input source

On-chip precision oscillator

On-chip low power oscillator

External (32.768 kHz) watch crystal

JTAG port supports code download and debug

Memory

96 kB Flash/EE memory, 6 kB SRAM

10k-cycle Flash/EE endurance, 20-year Flash/EE retention

In-circuit download via JTAG and LIN

64 \times 16-bit result FIFO for current and voltage ADC

On-chip peripherals

LIN 1.3- and 2.0-compatible (slave) support via UART with hardware synchronization

Flexible wake-up I/O pin, master/slave SPI serial I/O

9-pin GPIO port, 2 \times general-purpose timers

Wake-up and watchdog timers

Power supply monitor, on-chip power-on reset

Power

Operates directly from 12 V battery supply

Current consumption

Normal mode: 10 mA at 10 MHz

Low power monitor mode: 175 μ A

Package and temperature range

48-lead, 7 mm \times 7 mm LQFP

Fully specified for -40° C to $+105^{\circ}$ C operation

APPLICATIONS

Battery sensing/management for automotive systems

FUNCTIONAL BLOCK DIAGRAM

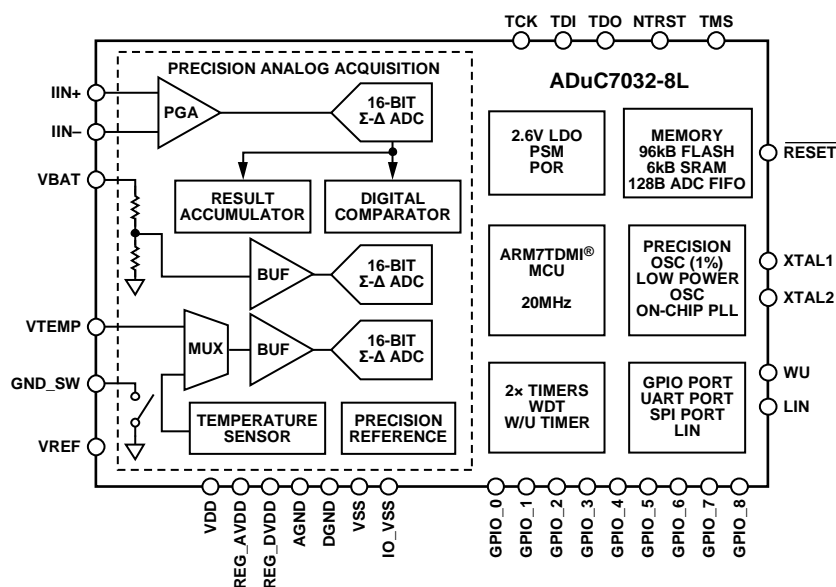

Figure 1.

Rev. A

Information furnished by Analog Devices is believed to be accurate and reliable. However, no responsibility is assumed by Analog Devices for its use, nor for any infringements of patents or other rights of third parties that may result from its use. Specifications subject to change without notice. No license is granted by implication or otherwise under any patent or patent rights of Analog Devices. Trademarks and registered trademarks are the property of their respective owners.

TABLE OF CONTENTS

Features	1	Interrupt System	67
Applications	1	Timers	69
Functional Block Diagram	1	Synchronization of Timers Across Asynchronous Clock Domains	70
Revision History	3	Programming the Timers	71
Specifications	4	Timer0—Lifetime Timer	71
Electrical Specifications	4	Timer1	73
Timing Specifications	9	Timer2—Wake-Up Timer	75
Absolute Maximum Ratings	15	Timer3—Watchdog Timer	77
ESD Caution	15	General-Purpose I/O	79
Pin Configuration and Function Descriptions	16	High Voltage Peripheral Control Interface	89
Terminology	19	WU (Wake-Up) Pin	95
Theory of Operation	20	Handling Interrupts from the High Voltage Peripheral Control Interface	96
Overview of the ARM7TDMI® Core	20	Low Voltage Flag (LVF)	96
Memory Organization	22	High Voltage Diagnostics	96
Reset	24	UART Serial Interface	97
Flash/EE Memory and the ADuC7032-8L	25	Baud Rate Generation	97
Flash/EE Control Interface	25	UART Register Definitions	97
Flash/EE Memory Security	28	Serial Peripheral Interface	101
Flash/EE Memory Reliability	31	MISO (Master In, Slave Out Data I/O Pin)	101
Code Execution Time from SRAM and Flash/EE	31	MOSI (Master Out, Slave In Pin)	101
ADuC7032-8L Kernel	32	SCLK (Serial Clock I/O Pin)	101
Memory Mapped Registers	34	Chip Select (\overline{SS}) Input Pin	101
Complete MMR Listing	35	SPI Registers Definitions	101
16-Bit, Sigma-Delta Analog-to-Digital Converters	39	LIN (Local Interconnect Network) Interface	104
Current Channel ADC (I-ADC)	39	LIN MMR Description	104
Voltage Channel ADC (V-ADC)	40	LIN Hardware Interface	108
Temperature Channel ADC (T-ADC)	40	ADuC7032-8L On-Chip Diagnostics	112
ADC Ground Switch	41	ADC Diagnostics	112
ADC Noise Performance Tables	42	High Voltage I/O Diagnostics	112
ADC MMR Interface	43	Part Identification	113
ADC Power Modes of Operation	54	ADuC7032-8L Example Schematic	116
ADC Diagnostics	59	Outline Dimensions	117
Power Supply Support Circuits	60	Ordering Guide	117
ADuC7032-8L System Clocks	61		
ADuC7032-8L Low Power Clock Calibration	65		
Processor Reference Peripherals	67		

REVISION HISTORY**11/10—Rev. 0 to Rev. A**

Changed ± 4.68 mV to ± 9.375 mV, Table 32	42
Changes to Timers Section	69
Added Synchronization of Timers Across Asynchronous Clock Domains Section	70
Added Figure 32 and Figure 33; Renumbered Sequentially	70
Added Programming the Timers Section, Halting Timer2 Section, Starting Timer2 Section, and Example Code Section	71
Updated Outline Dimensions	117
Changes to Ordering Guide	117

8/07—Revision 0: Initial Version

SPECIFICATIONS

ELECTRICAL SPECIFICATIONS

VDD = 3.5 V to 18 V, VREF = 1.2 V internal reference; $f_{CORE} = 10.24$ MHz, driven from external 32.768 kHz watch crystal or on-chip precision oscillator. All specifications $T_A = -40^{\circ}\text{C}$ to $+105^{\circ}\text{C}$, unless otherwise noted.

Table 1.

Parameter	Test Conditions/Comments	Min	Typ	Max	Unit
ADC SPECIFICATIONS					
Conversion Rate ¹					
	Chop off, ADC normal operating mode	4		8000	Hz
	Chop on, ADC normal operating mode	4		2600	Hz
	Chop on, ADC low power mode	1		650	Hz
Current Channel					
No Missing Codes ¹	Valid for all ADC update rates and ADC modes	16			Bits
Integral Nonlinearity ^{1,2}			±10	±60	ppm of FSR
Offset Error ^{1,2,3,4,5}	Chop off, 1 LSB = (36.6/gain) μV , after initial offset calibration	-10	±3	+10	LSB
Offset Error ^{2,3,4,6}	Chop off, 1 LSB = (36.6/gain) μV	-15		+35	LSB
Offset Error ^{1,3,6}	Chop on	-2	±0.5	+2	μV
Offset Error ^{1,3}	Chop on, low power mode or low power plus mode, MCU powered down	0	-200	-650	nV
Offset Error ^{1,3}	Chop on, normal mode, CD = 1	0	-1.5	-5	μV
Offset Error Drift ⁶	Chop off, valid for ADC gains of 4 to 64, normal mode		0.03		LSB/ $^{\circ}\text{C}$
Offset Error Drift ⁶	Chop off, valid for ADC gains of 128 to 512, normal mode		30		nV/ $^{\circ}\text{C}$
Offset Error Drift ⁶	Chop on		10		nV/ $^{\circ}\text{C}$
Total Gain Error ^{1,3,7,8,9}	Normal mode	-0.5	±0.1	+0.5	%
Total Gain Error ^{1,3,7,9,10}	Low power mode	-4	±0.2	+4	%
Total Gain Error ^{1,3,7,9}	Low power plus mode, using precision VREF	-1	±0.2	+1	%
Gain Drift			3		ppm/ $^{\circ}\text{C}$
PGA Gain Mismatch Error			±0.1		%
Output Noise ^{1,11}	4 Hz update rate, gain = 512, chop enabled		60	90	nV rms
	10 Hz update rate, gain = 512, chop enabled		100	150	nV rms
	1 kHz update rate, gain = 512		0.6	0.9	μV rms
	1 kHz update rate, gain = 32		0.8	1.2	μV rms
	1 kHz update rate, gain = 4		2.0	2.8	μV rms
	8 kHz update rate, gain = 32		2.5	3.5	μV rms
	8 kHz update rate, gain = 4		14	21	μV rms
	ADC low power mode, $f_{ADC} = 10$ Hz, gain = 128		1.25	1.9	μV rms
	ADC low power mode, $f_{ADC} = 1$ Hz, gain = 128		0.35	0.5	μV rms
	ADC low power plus mode, $f_{ADC} = 1$ Hz, gain = 512		0.1	0.15	μV rms
Voltage Channel ¹²					
No Missing Codes ¹	Valid at all ADC update rates	16			Bits
Integral Nonlinearity ¹			±10	±60	ppm of FSR
Offset Error ^{1,3,5}	Chop off, 1 LSB = 439.5 μV	-10	±1	+10	LSB
Offset Error ^{1,3}	Chop on		0.3	1	LSB
Offset Error Drift	Chop off		0.03		LSB/ $^{\circ}\text{C}$
Total Gain Error ^{1,3,7,13,14}	Includes resistor mismatch	-0.25	±0.06	+0.25	%
Total Gain Error ^{1,3,7,13,14}	Temperature range = -25°C to $+65^{\circ}\text{C}$	-0.15	±0.03	+0.15	%
Gain Drift	Includes resistor mismatch drift		3		ppm/ $^{\circ}\text{C}$
Output Noise ^{1,15}	4 Hz update rate		60	90	μV rms
	10 Hz update rate		60	90	μV rms
	1 kHz update rate		180	270	μV rms
	8 kHz update rate		1600	2400	μV rms

Parameter	Test Conditions/Comments	Min	Typ	Max	Unit
Temperature Channel					
No Missing Codes ¹	Valid at all ADC update rates	16			Bits
Integral Nonlinearity ¹			±10	±60	ppm of FSR
Offset Error ^{1,3,5,16,17,18}	Chop off, 1 LSB = 19.84 μV	-10	±3	+10	LSB
Offset Error ^{1,3}	Chop on	-5	1	+5	LSB
Offset Error Drift			0.03		LSB/°C
Total Gain Error ^{1,3,14,17,18}		-0.25	±0.06	+0.25	%
Gain Drift			3		ppm/°C
Output Noise ¹	1 kHz update rate		7.5	11.25	μV rms
ADC SPECIFICATIONS, ANALOG INPUT	Internal VREF = 1.2 V				
Current Channel					
Absolute Input Voltage Range	Applies to both IIN+ and IIN-	-200		+300	mV
Input Voltage Range ^{19,20}	Gain = 1 ²¹		±1.2		V
	Gain = 2 ²¹		±600		mV
	Gain = 4 ²¹		±300		mV
	Gain = 8		±150		mV
	Gain = 16		±75		mV
	Gain = 32		±37.5		mV
	Gain = 64		±18.75		mV
	Gain = 128		±9.375		mV
	Gain = 256		±4.68		mV
	Gain = 512		±2.3		mV
Input Leakage Current ¹		-3		+3	nA
Input Offset Current ^{1,22}			0.5	1.5	nA
Voltage Channel					
Absolute Input Voltage Range		4		18	V
Input Voltage Range			0 to 28.8		V
VBAT Input Current	VBAT = 18 V	3	5.5	8	μA
Temperature Channel					
Absolute Input Voltage Range		100		1300	mV
Input Voltage Range			0 to VREF		V
VTEMP Input Current ¹			2.5	100	nA
VOLTAGE REFERENCE					
ADC Precision Reference			1.2		V
Internal VREF			0.5		ms
Power-Up Time ¹					
Initial Accuracy ¹	Measured at T _A = 35°C	-0.15		+0.15	%
Internal VREF Temperature Coefficient ^{1,23}		-20	±5	+20	ppm/°C
Long-Term Stability ²⁴			100		ppm/ 1000 hr
External Reference Input Range ²⁵		0.1		1.3	V
VREF Divide-by-2 Initial Error ¹			0.1	0.3	%
ADC Low Power Reference					
Internal VREF			1.2		V
Initial Accuracy	Measured at T _A = 35°C	-5		+5	%
Initial Accuracy ¹⁰	Using ADCREF, measured at T _A = 35°C		0.1		%
Temperature Coefficient ^{1,23}		-300		+300	ppm/°C
RESISTIVE ATTENUATOR					
Divider Ratio			24		
Resistor Mismatch Drift			3		ppm/°C
ADC GROUND SWITCH					
Resistance	Direct path to ground		10		Ω
	20 kΩ resistor selected	10	20	30	kΩ
Input Current				6	mA

ADuC7032-8L

Parameter	Test Conditions/Comments	Min	Typ	Max	Unit
TEMPERATURE SENSOR ^{1, 26} Accuracy	MCU in power-down or standby mode; temperature range = -40°C to -30°C MCU in power-down or standby mode; temperature range = -30°C to -16°C MCU in power-down or standby mode; temperature range = -16°C to +40°C MCU in power-down or standby mode; temperature range = +40°C to +70°C MCU in power-down or standby mode; temperature range = +70°C to +85°C MCU in power-down or standby mode; temperature range = +85°C to +105°C	-4 -3 -2 -4 -8 -12		+4 +3 +2 +4 +8 +12	°C °C °C °C °C °C
POWER-ON RESET (POR) POR Trip Level POR Hysteresis Reset Timeout from POR	Refers to voltage at VDD pin	2.85	3.0 300 20	3.15	V mV ms
LOW VOLTAGE FLAG (LVF) LVF Level	Refers to voltage at VDD pin	1.9	2.1	2.3	V
POWER SUPPLY MONITOR (PSM) PSM Trip Level	Refers to voltage at VDD pin		6.0		V
WATCHDOG TIMER (WDT) Timeout Period ¹ Timeout Step Size	32.768 kHz clock, 256 prescale	0.008	7.8	512	sec ms
FLASH/EE MEMORY ¹ Endurance ²⁷ Data Retention ²⁸		10,000 20			Cycles Years
DIGITAL INPUTS Input Leakage Current Input Pull-Up Current Input Capacitance Input Leakage Current Input Pull-Down Current	All digital inputs except NTRST Input (high) = REG_DVDD Input (low) = 0 V NTRST only: input (low) = 0 V NTRST only: input (high) = REG_DVDD	-10 -80 -10 30	±1 -20 10 ±1 55	+10 -10 +10 100	µA µA pF µA µA
LOGIC INPUTS ¹ Input Low Voltage (VINL) Input High Voltage (VINH)	All logic inputs			0.4 2.0	V V
CRYSTAL OSCILLATOR ¹ Logic Inputs, XTAL1 Only Input Low Voltage (VINL) Input High Voltage (VINH) XTAL1 Capacitance XTAL2 Capacitance		1.7	12 12	0.8	V V pF pF
ON-CHIP OSCILLATORS Low Power Oscillator Accuracy ²⁹ Precision Oscillator Accuracy	Includes drift data from 1000 hr life test Includes drift data from 1000 hr life test	-3 -1	131.072 131.072	+3 +1	kHz % kHz %
MCU CLOCK RATE	Eight programmable core clock selections within this range (binary divisions 1, 2, 4, 8, . . .64, 128)	0.160	10.24	20.48	MHz
MCU START-UP TIME At Power-On After Reset Event From MCU Power-Down Oscillator Running Wake-Up from Interrupt Wake-Up from LIN Crystal Powered Down Wake-Up from Interrupt Internal PLL Lock Time	Includes kernel power-on execution time Includes kernel power-on execution time		25 5 2 2 500 1		ms ms ms ms ms ms

Parameter	Test Conditions/Comments	Min	Typ	Max	Unit
LIN I/O GENERAL					
Baud Rate		1000		20,000	Bits/sec
VDD	Supply voltage range at which the LIN interface is functional	7		18	V
Input Capacitance			5.5		pF
LIN Comparator Response Time ¹	Using 22 Ω resistor		38	90	μs
I _{LIN_DOM_MAX}	Current limit for driver when LIN bus is in dominant state; VBAT = VBAT(MAX)	40		200	mA
I _{LIN_PAS_REC}	Driver off; 7.0 V < V _{BUS} < 18 V; VDD = V _{LIN} – 0.7 V	–20		+20	μA
I _{LIN_PAS_DOM} ¹	Input leakage V _{LIN} = 0 V	–1			mA
I _{LIN_NO_GND} ³⁰	Control unit disconnected from ground, GND = VDD; 0 V < V _{LIN} < 18 V; VBAT = 12 V	–1		+1	mA
V _{LIN_DOM} ¹	LIN receiver dominant state, VDD > 7.0 V			0.4 VDD	V
V _{LIN_REC} ¹	LIN receiver recessive state, VDD > 7.0 V	0.6 VDD			V
V _{LIN_CNT} ¹	LIN receiver center voltage, VDD > 7.0 V	0.475 VDD	0.5 VDD	0.525 VDD	V
V _{HYS} ¹	LIN receiver hysteresis voltage			0.175 VDD	V
V _{LIN_DOM_DRV_LOSUP} ¹	LIN dominant output voltage; VDD = 7.0 V				
R _L 500 Ω				1.2	V
R _L 1000 Ω		0.6			V
V _{LIN_DOM_DRV_HISUP} ¹	LIN dominant output voltage; VDD = 18 V				
R _L 500 Ω				2	V
R _L 1000 Ω		0.8			V
V _{LIN_RECESSIVE}	LIN recessive output voltage	0.8 VDD			V
VBAT Shift ³⁰		0		0.1 VDD	V
GND Shift ³⁰		0		0.1 VDD	V
R _{SLAVE}	Slave termination resistance	20	29	47	kΩ
V _{SERIAL_DIODE} ³⁰	Voltage drop at the serial diode, D _{Ser_Int}	0.4	0.7	1	V
Transmit Propagation Delay ¹	V _{DDMIN} = 7 V			4	μs
	Bus load conditions (C _{BUS} R _{BUS}): 1 nF 1 kΩ; 6.8 nF 660 Ω; 10 nF 500 Ω				
Symmetry of Transmit					
Propagation Delay ¹	V _{DDMIN} = 7 V	–2		+2	μs
Receive Propagation Delay ¹	V _{DDMIN} = 7 V			6	μs
Symmetry of Receive					
Propagation Delay ¹	V _{DDMIN} = 7 V	–2		+2	μs
LIN v.1.3 SPECIFICATION					
	Bus load conditions (C _{BUS} R _{BUS}): 1 nF 1 kΩ; 6.8 nF 660 Ω; 10 nF 500 Ω				
$\left \frac{dV}{dt} \right _1$	Slew rate Dominant and recessive edges, VBAT = 18 V	1	2	3	V/μs
$\left \frac{dV}{dt} \right _1$	Slew rate Dominant and recessive edges, VBAT = 7 V	0.5		3	V/μs
t _{SYM} ¹	Symmetry of rising and falling edge, VBAT = 18 V	–5		+5	μs
	Symmetry of rising and falling edge, VBAT = 7 V	–4		+4	μs
LIN 2.0 SPECIFICATION					
	Bus load conditions (C _{BUS} R _{BUS}): 1 nF 1 kΩ; 6.8 nF 660 Ω; 10 nF 500 Ω				
D1	Duty Cycle 1 T _{HREC(MAX)} = 0.744 × VBAT, T _{HDOM(MAX)} = 0.581 × VBAT, V _{SUP} = 7.0 V...18 V; t _{BIT} = 50 μs, D1 = t _{BUS_REC(MIN)} /(2 × t _{BIT})	0.396			
D2	Duty Cycle 2 T _{HREC(MIN)} = 0.284 × VBAT, T _{HDOM(MIN)} = 0.422 × VBAT, V _{SUP} = 7.0 V...18 V; t _{BIT} = 50 μs, D2 = t _{BUS_REC(MAX)} /(2 × t _{BIT})			0.581	

ADuC7032-8L

Parameter	Test Conditions/Comments	Min	Typ	Max	Unit
PACKAGE THERMAL SPECIFICATIONS					
Thermal Shutdown ³¹	48-lead LQFP, stacked die Top die Bottom die	140	150	160	°C
Thermal Impedance (θ_{JA}) ³²			50		°C/W
				25	
POWER REQUIREMENTS					
Power Supply Voltages					
VDD (Battery Supply)		3.5		18	V
REG_DVDD, REG_AVDD ³³		2.5	2.6	2.7	V
Power Consumption					
I _{DD} (MCU Normal Mode) ³⁴	MCU clock rate = 10.24 MHz, ADC off		10	20	mA
	MCU clock rate = 20.48 MHz, ADC off		20	30	mA
I _{DD} (MCU Powered Down) ¹	ADC low power mode, measured over an ambient temperature range of -10°C to +40°C (continuous ADC conversion)		300	400	μA
	ADC low power mode, measured over an ambient temperature range of -40°C to +85°C (continuous ADC conversion)		300	500	μA
	ADC low power plus mode, measured over an ambient temperature range of -10°C to +40°C (continuous ADC conversion)		520	700	μA
	Average current, measured with wake-up and watchdog timer clocked from low power oscillator (-40°C to +85°C)		120	300	μA
	Average current, measured with wake-up and watchdog timer clocked from low power oscillator over an ambient temperature range of -10°C to +40°C		120	175	μA
I _{DD} (Current ADC)			1.7		mA
I _{DD} (Voltage/Temperature ADC)	Per ADC		0.5		mA
I _{DD} (Precision Oscillator)			400		μA

¹ Not guaranteed by production test, but by design and/or characterization data at production release.

² Valid for current ADC gain setting of PGA = 4 to 64.

³ These numbers include temperature drift.

⁴ Tested at gain range = 4; self-offset calibration removes this error.

⁵ Measured with an internal short after an initial offset calibration.

⁶ Measured with an internal short.

⁷ Includes internal reference temperature drift.

⁸ Factory calibrated at gain = 1.

⁹ System calibration at specific gain range removes the error at this gain range at that temperature.

¹⁰ Valid when used in conjunction with the ADCREF (the low power mode reference error) MMR.

¹¹ Typical noise in low power modes is measured with chop enabled.

¹² Voltage channel specifications include resistive attenuator input stage.

¹³ Includes an initial system calibration.

¹⁴ System calibration removes this error at that temperature.

¹⁵ RMS noise is referred to voltage attenuator input. For example, at $f_{ADC} = 1$ kHz, typical rms noise at the ADC input is 7.5 μV, which, when scaled by the attenuator (24), yields these input referred noise figures.

¹⁶ ADC self-offset calibration removes this error.

¹⁷ Valid after an initial self-calibration.

¹⁸ Factory calibrated for the internal temperature sensor during final production test.

¹⁹ In ADC low power mode, the input range is fixed at ±9.375 mV. In ADC low power plus mode, the input range is fixed at ±2.34375 mV.

²⁰ It is possible to extend the ADC input range by up to 10% by modifying the factory set value of the gain calibration register or using system calibration. This approach can also be used to reduce the ADC input range (LSB size).

²¹ Limited by minimum/maximum absolute input voltage range.

²² Valid for a differential input less than 10 mV.

²³ Measured using box method.

²⁴ The long-term stability specification is noncumulative. The drift in subsequent 1000 hour periods is significantly lower than in the first 1000 hour period.

²⁵ References of up to REG_AVDD can be accommodated by enabling an internal divide-by-2.

²⁶ Die temperature.

²⁷ Endurance is qualified to 10,000 cycles, as per JEDEC Std. 22 Method A117, and measured at -40°C, +25°C, and +125°C. Typical endurance at 25°C is 170,000 cycles.

²⁸ Retention lifetime equivalent at junction temperature (T_J) = 85°C, as per JEDEC Std. 22 Method A117. Retention lifetime derates with junction temperature.

²⁹ Low power oscillator can be calibrated against either the precision oscillator or the external 32.768 kHz crystal in user code.

³⁰ These numbers are not production tested but are supported by LIN compliance testing.

³¹ The MCU core is not shut down, but an interrupt is generated, if enabled.

³² Thermal impedance can be used to calculate the thermal gradient from ambient to die temperature.

³³ Internal regulated supply available at REG_DVDD ($I_{SOURCE} = 5$ mA) and REG_AVDD ($I_{SOURCE} = 1$ mA).

³⁴ Typical additional supply current consumed during Flash/EE memory program and erase cycles is 7 mA and 5 mA, respectively.

TIMING SPECIFICATIONS

SPI Timing Specifications

Table 2. SPI Master Mode Timing (PHASE Mode = 1)

Parameter	Description	Min	Typ	Max	Unit
t_{SL}	SCLK low pulse width ¹		$(SPIDIV + 1) \times t_{HCLK}$		ns
t_{SH}	SCLK high pulse width ¹		$(SPIDIV + 1) \times t_{HCLK}$		ns
t_{DAV}	Data output valid after SCLK edge ²			$(2 \times t_{UCLK}) + (2 \times t_{HCLK})$	ns
t_{DSU}	Data input setup time before SCLK edge	0			ns
t_{DHD}	Data input hold time after SCLK edge ²	$3 \times t_{UCLK}$			ns
t_{DF}	Data output fall time		3.5		ns
t_{DR}	Data output rise time		3.5		ns
t_{SR}	SCLK rise time		3.5		ns
t_{SF}	SCLK fall time		3.5		ns

¹ t_{HCLK} depends on the clock divider or CD bits in PLLCON MMR. $t_{HCLK} = t_{UCLK}/2^{CD}$.

² $t_{UCLK} = 48.8$ ns. It corresponds to the 20.48 MHz internal clock from the PLL before the clock divider.

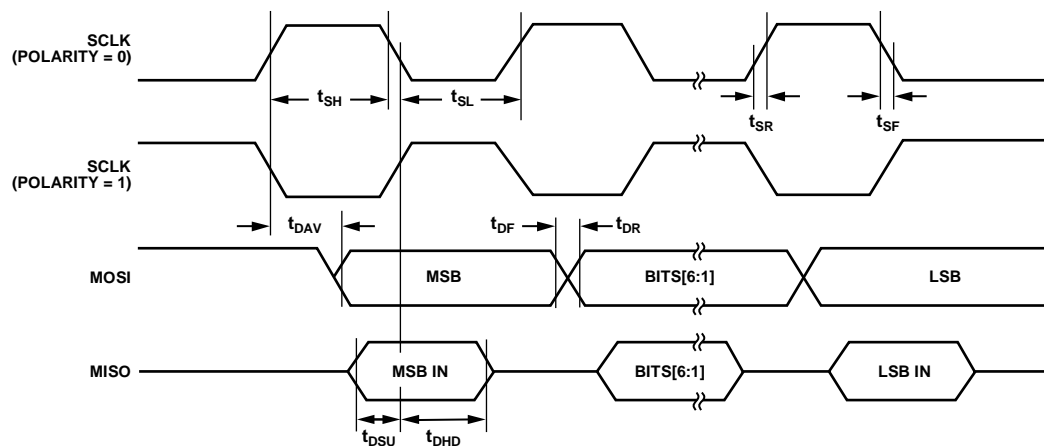

Figure 2. SPI Master Mode Timing (PHASE Mode = 1)

05896-002

ADuC7032-8L

Table 3. SPI Master Mode Timing (PHASE Mode = 0)

Parameter	Description	Min	Typ	Max	Unit
t_{SL}	SCLK low pulse width ¹		$(SPIDIV + 1) \times t_{HCLK}$		ns
t_{SH}	SCLK high pulse width ¹		$(SPIDIV + 1) \times t_{HCLK}$		ns
t_{DAV}	Data output valid after SCLK edge ²			$(2 \times t_{UCLK}) + (2 \times t_{HCLK})$	ns
t_{DOSU}	Data output setup time before SCLK edge		$\frac{1}{2} t_{SL}$		ns
t_{DSU}	Data input setup time before SCLK edge	0			ns
t_{DHD}	Data input hold time after SCLK edge ²	$3 \times t_{UCLK}$			ns
t_{DF}	Data output fall time		3.5		ns
t_{DR}	Data output rise time		3.5		ns
t_{SR}	SCLK rise time		3.5		ns
t_{SF}	SCLK fall time		3.5		ns

¹ t_{HCLK} depends on the clock divider or CD bits in PLLCON MMR. $t_{HCLK} = t_{UCLK}/2^{CD}$.

² $t_{UCLK} = 48.8$ ns. It corresponds to the 20.48 MHz internal clock from the PLL before the clock divider.

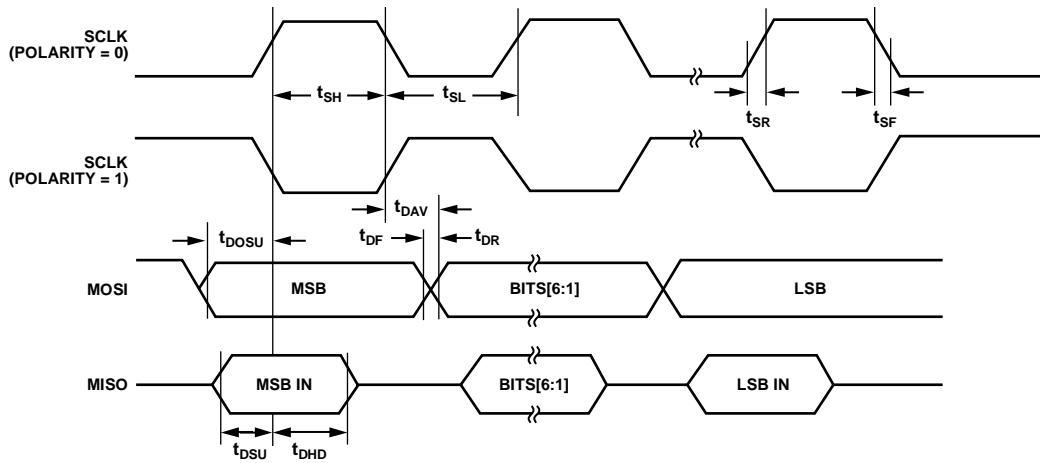

Figure 3. SPI Master Mode Timing (PHASE Mode = 0)

05986-003

Table 4. SPI Slave Mode Timing (PHASE Mode = 1)

Parameter	Description	Min	Typ	Max	Unit
$t_{\overline{SS}}$	\overline{SS} to SCLK edge		$\frac{1}{2} t_{SL}$		ns
t_{SL}	SCLK low pulse width ¹		$(SPIDIV + 1) \times t_{HCLK}$		ns
t_{SH}	SCLK high pulse width ¹		$(SPIDIV + 1) \times t_{HCLK}$		ns
t_{DAV}	Data output valid after SCLK edge ²			$(3 \times t_{UCLK}) + (2 \times t_{HCLK})$	ns
t_{DSU}	Data input setup time before SCLK edge	0			ns
t_{DHD}	Data input hold time after SCLK edge ²	$4 \times t_{UCLK}$			ns
t_{DF}	Data output fall time		3.5		ns
t_{DR}	Data output rise time		3.5		ns
t_{SR}	SCLK rise time		3.5		ns
t_{SF}	SCLK fall time		3.5		ns
t_{SFS}	\overline{SS} high after SCLK edge		$\frac{1}{2} t_{SL}$		ns

¹ t_{HCLK} depends on the clock divider or CD bits in PLLCON MMR. $t_{HCLK} = t_{UCLK}/2^{CD}$.

² $t_{UCLK} = 48.8$ ns. It corresponds to the 20.48 MHz internal clock from the PLL before the clock divider.

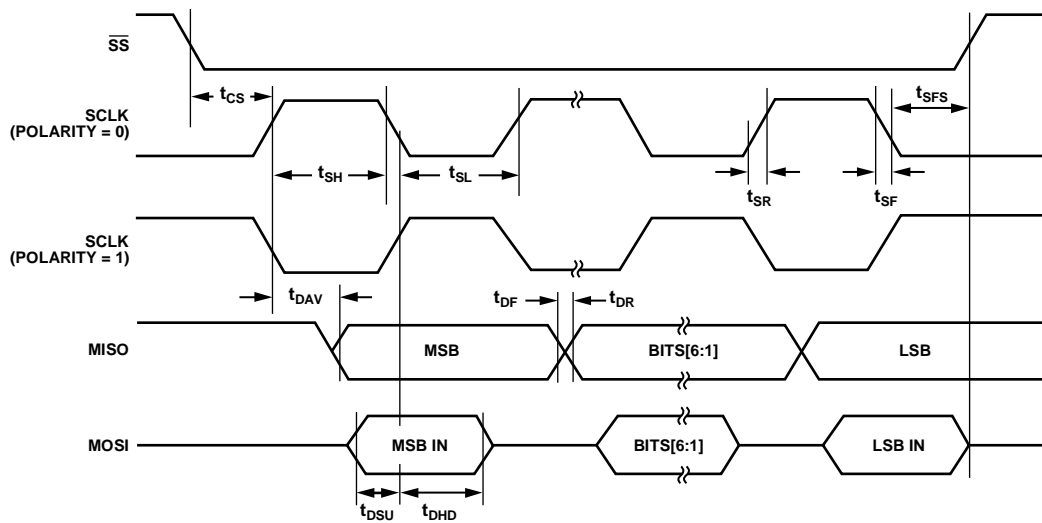

Figure 4. SPI Slave Mode Timing (PHASE Mode = 1)

0558B-004

ADuC7032-8L

Table 5. SPI Slave Mode Timing (PHASE Mode = 0)

Parameter	Description	Min	Typ	Max	Unit
$t_{\overline{SS}}$	\overline{SS} to SCLK edge		$\frac{1}{2} t_{SL}$		ns
t_{SL}	SCLK low pulse width ¹		$(SPIDIV + 1) \times t_{HCLK}$		ns
t_{SH}	SCLK high pulse width ¹		$(SPIDIV + 1) \times t_{HCLK}$		ns
t_{DAV}	Data output valid after SCLK edge ²			$(3 \times t_{UCLK}) + (2 \times t_{HCLK})$	ns
t_{DSU}	Data input setup time before SCLK edge	0			ns
t_{DHD}	Data input hold time after SCLK edge ²	$4 \times t_{UCLK}$			ns
t_{DF}	Data output fall time		3.5		ns
t_{DR}	Data output rise time		3.5		ns
t_{SR}	SCLK rise time		3.5		ns
t_{SF}	SCLK fall time		3.5		ns
t_{DOCS}	Data output valid after \overline{SS} edge ²			$(3 \times t_{UCLK}) + (2 \times t_{HCLK})$	ns
t_{SFS}	\overline{SS} high after SCLK edge		$\frac{1}{2} t_{SL}$		ns

¹ t_{HCLK} depends on the clock divider or CD bits in PLLCON MMR. $t_{HCLK} = t_{UCLK}/2^{CD}$.

² $t_{UCLK} = 48.8$ ns. It corresponds to the 20.48 MHz internal clock from the PLL before the clock divider.

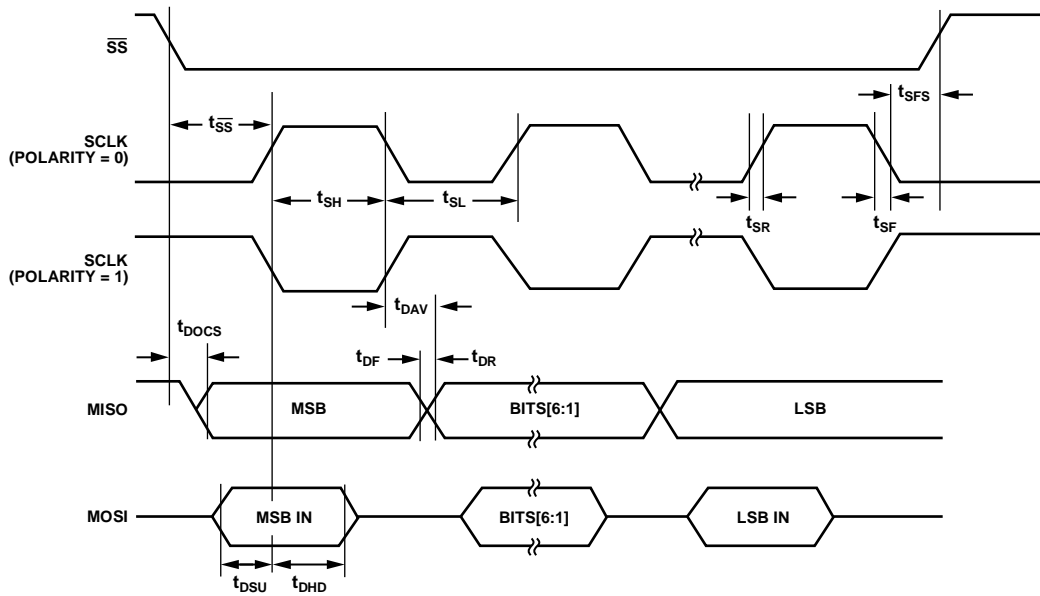

Figure 5. SPI Slave Mode Timing (PHASE Mode = 0)

05986-005

LIN Timing Specifications

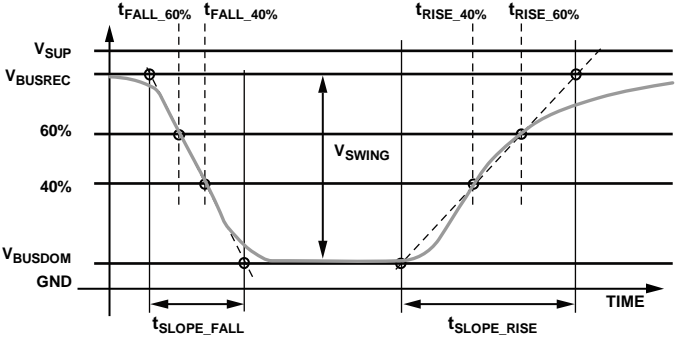
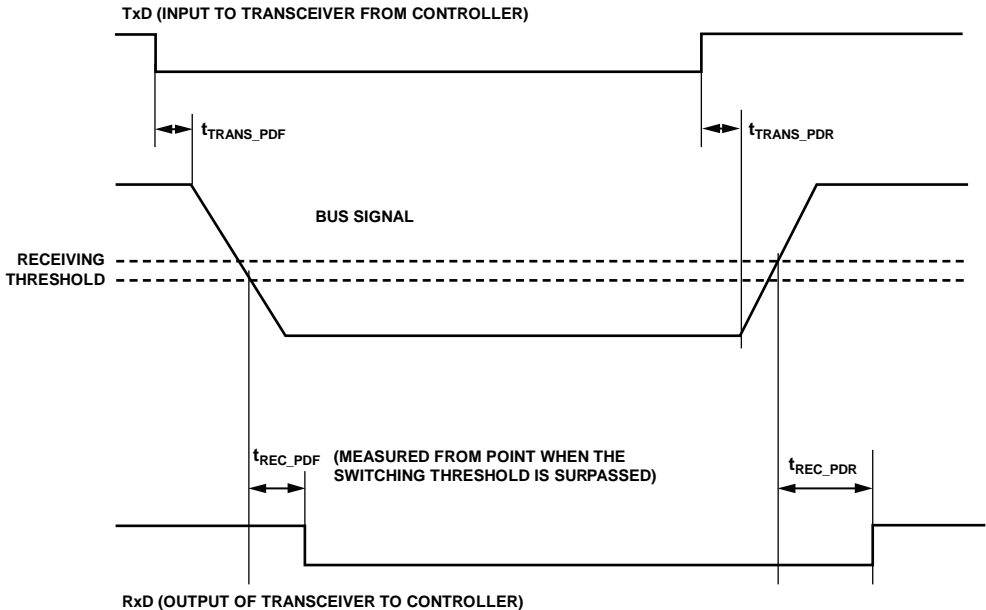

Figure 6. LIN v.1.3 Timing Specifications

05986C-006

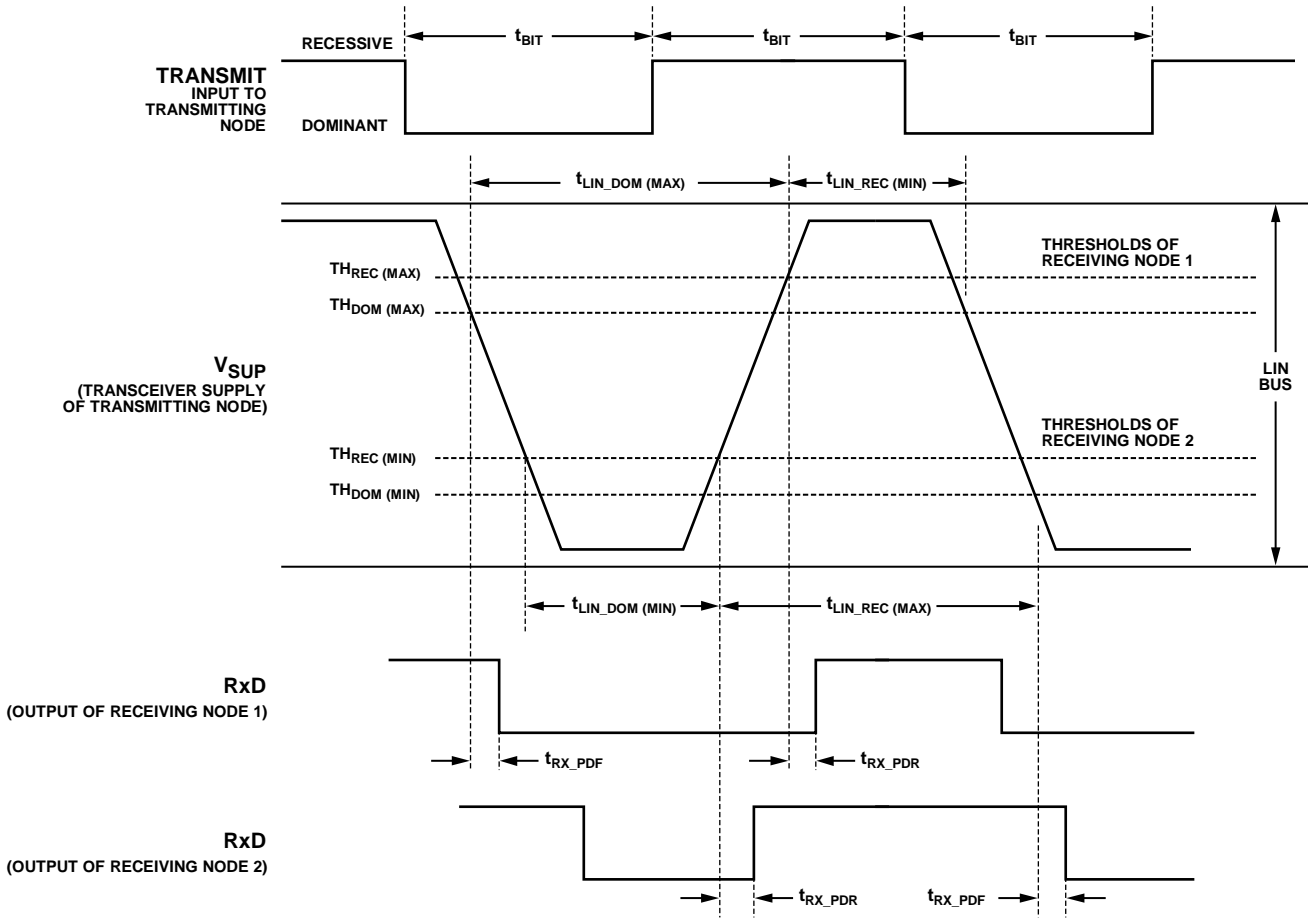

Figure 7. LIN 2.0 Timing Specifications

05986-007

ABSOLUTE MAXIMUM RATINGS

$T_A = -40^{\circ}\text{C}$ to $+105^{\circ}\text{C}$, unless otherwise noted.

Table 6.

Parameter	Rating
AGND to DGND to VSS to IO_VSS	-0.3 V to +0.3 V
VBAT to AGND	-22 V to +40 V
VDD to VSS	-0.3 V to +33 V
VDD to VSS for 1 sec	-0.3 V to +40 V
LIN to IO_VSS	-16 V to +40 V
WU to IO_VSS	-3 V to +33 V
WU Continuous Current	50 mA
High Voltage I/O Pins Short-Circuit Current	100 mA
Digital I/O Voltage to DGND	-0.3 V to REG_DVDD + 0.3 V
VREF to AGND	-0.3 V to REG_AVDD + 0.3 V
ADC Inputs to AGND	-0.3 V to REG_AVDD + 0.3 V
Storage Temperature	130°C
Junction Temperature (Transient)	150°C
Junction Temperature (Continuous)	130°C
Lead Temperature	
Soldering Reflow (15 sec)	260°C

Stresses above those listed under Absolute Maximum Ratings may cause permanent damage to the device. This is a stress rating only; functional operation of the device at these or any other conditions above those indicated in the operational section of this specification is not implied. Exposure to absolute maximum rating conditions for extended periods may affect device reliability.

ESD CAUTION



ESD (electrostatic discharge) sensitive device.

Charged devices and circuit boards can discharge without detection. Although this product features patented or proprietary protection circuitry, damage may occur on devices subjected to high energy ESD. Therefore, proper ESD precautions should be taken to avoid performance degradation or loss of functionality.

PIN CONFIGURATION AND FUNCTION DESCRIPTIONS

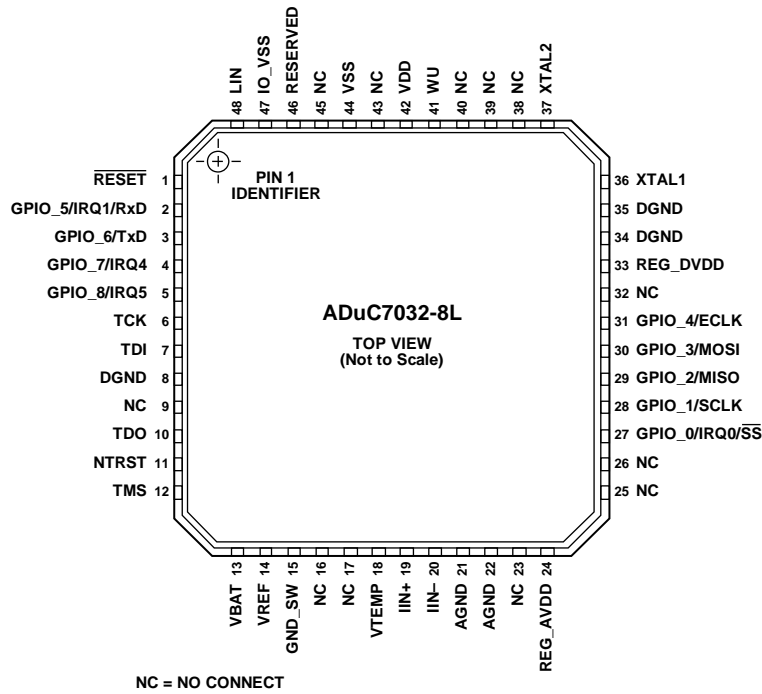

Figure 8. Pin Configuration

Table 7. Pin Function Descriptions

Pin No.	Mnemonic	Type ¹	Description
1	RESET	I	Reset Input Pin, Active Low. This pin has an internal, weak, pull-up resistor to REG_DVDD. When not in use, this pin remains unconnected. For added security and robustness, it is recommended that this pin be strapped, via a resistor, to REG_DVDD.
2	GPIO_5/IRQ1/RxD	I/O	General-Purpose Digital Input/Output 5, External Interrupt Request 1, or Receive Data. By default and after power-on reset, this pin is configured as an input. The pin has an internal, weak, pull-up resistor and, when not in use, it can be left unconnected. This multifunction pin can be configured in one of three states, namely General-Purpose Digital I/O 5. External Interrupt Request 1, active high. Receive data for UART serial port. This pin can also be used as a clock input to Timer1.
3	GPIO_6/TxD	I/O	General-Purpose Digital Input/Output 6 or Transmit Data. By default and after power-on reset, this pin is configured as an input. The pin has an internal, weak, pull-up resistor and, when not in use, it can be left unconnected. This multifunction pin can be configured in one of two states, namely General-Purpose Digital I/O 6. Transmit data for UART serial port.
4	GPIO_7/IRQ4	I/O	General-Purpose Digital Input/Output 7 or External Interrupt Request 4. By default and after power-on reset, this pin is configured as an input. The pin has an internal, weak, pull-up resistor and, when not in use, it can be left unconnected. This multifunction pin can be configured in one of two states, namely General-Purpose Digital I/O 7. External Interrupt Request 4, active high.
5	GPIO_8/IRQ5	I/O	General-Purpose Digital Input/Output 8 or External Interrupt Request 5. By default and after power-on reset, this pin is configured as an input. The pin has an internal, weak, pull-up resistor and, when not in use, it can be left unconnected. This multifunction pin can be configured in one of two states, namely General-Purpose Digital I/O 8. External Interrupt Request 5, active high. This pin can also be used as a clock input to Timer1.

Pin No.	Mnemonic	Type ¹	Description
6	TCK	I	JTAG Test Clock. This clock input pin is one of the standard 5-pin JTAG debug ports on the part. It is an input pin only, and it has an internal, weak, pull-up resistor. When not in use, this pin remains unconnected.
7	TDI	I	JTAG Test Data Input. This data input pin is one of the standard 5-pin JTAG debug ports on the part. It is an input pin only, and it has an internal, weak, pull-up resistor. When not in use, this pin remains unconnected.
8, 34, 35	DGND	S	Ground Reference for On-Chip Digital Circuits.
9, 16, 17, 23, 25, 26, 32, 38, 39, 40, 43, 45	NC		No Connect. This pin is not connected internally but is reserved for possible future use. Therefore, this pin should not be connected externally. NC pins can be grounded, if required.
10	TDO	O	JTAG Test Data Output. This data output pin is one of the standard 5-pin JTAG debug ports on the part. It is an output pin only. At power-on, this output is disabled and pulled high via an internal, weak, pull-up resistor. When not in use, this pin remains unconnected.
11	NTRST	I	JTAG Test Reset. This reset input pin is one of the standard 5-pin JTAG debug ports on the part. It is an input pin only, and it has an internal, weak, pull-down resistor. When not in use, this pin remains unconnected. It is also monitored by the on-chip kernel to enable LIN boot load mode.
12	TMS	I	JTAG Test Mode Select. This mode select input pin is one of the standard 5-pin JTAG debug ports on the part. It is an input pin only, and it has an internal, weak, pull-up resistor. When not in use, this pin remains unconnected.
13	VBAT	I	Battery Voltage Input to Resistor Divider.
14	VREF	I	External Reference Input Terminal. If this input is not used, connect it directly to the AGND system ground.
15	GND_SW	S	Switch to Internal Analog Ground Reference. Negative input for external temperature channel and external reference. If this input is not used, connect it directly to the AGND system ground.
18	VTEMP	I	External Pin for NTC/PTC Temperature Measurement.
19	IIN+	I	Positive Differential Input for Current Channel.
20	IIN-	I	Negative Differential Input for Current Channel.
21, 22	AGND	S	Ground Reference for On-Chip Precision Analog Circuits.
24	REG_AVDD	S	Nominal 2.6 V Output from On-Chip Regulator.
27	GPIO_0/IRQ0/ \overline{SS}	I/O	General-Purpose Digital I/O 0, External Interrupt Request 0, or SPI Interface. By default and after power-on reset, this pin is configured as an input. The pin has an internal, weak, pull-up resistor and, when not in use, it remains unconnected. This multifunction pin can be configured in one of three states, namely General-Purpose Digital I/O 0. External Interrupt Request 0, active high. SPI interface, slave select input.
28	GPIO_1/SCLK	I/O	General-Purpose Digital I/O 1 or SPI Interface. By default and after power-on reset, this pin is configured as an input. The pin has an internal, weak, pull-up resistor and, when not in use, it remains unconnected. This multifunction pin can be configured in one of two states, namely General-Purpose Digital I/O 1. SPI interface, serial clock input.
29	GPIO_2/MISO	I/O	General-Purpose Digital I/O 2 or SPI Interface. By default and after power-on reset, this pin is configured as an input. The pin has an internal, weak, pull-up resistor and, when not in use, it remains unconnected. This multifunction pin can be configured in one of two states, namely General-Purpose Digital I/O 2. SPI interface, master input/slave output pin.
30	GPIO_3/MOSI	I/O	General-Purpose Digital I/O 3 or SPI Interface. By default and after power-on reset, this pin is configured as an input. The pin has an internal, weak, pull-up resistor and, when not in use, it remains unconnected. This multifunction pin can be configured in one of two states, namely General-Purpose Digital I/O 3. SPI interface, master output/slave input pin.
31	GPIO_4/ECLK	I/O	General-Purpose Digital I/O 4 or Clock Output. By default and after power-on reset, this pin is configured as an input. The pin has an internal, weak, pull-up resistor and, when not in use, it remains unconnected. This programmable digital I/O pin can also be configured to output a 2.56 MHz clock.
33	REG_DVDD	S	Nominal 2.6 V Output from the On-Chip Regulator.

ADuC7032-8L

Pin No.	Mnemonic	Type ¹	Description
36	XTAL1	O	Crystal Oscillator Output. If an external crystal is not in use, this pin remains unconnected.
37	XTAL2	I	Crystal Oscillator Input. If an external crystal is not in use, connect this pin to the DGND system ground.
41	WU	O	High Voltage Wake-Up Transmit Pin. When not in use, this pin remains unconnected.
42	VDD	S	Battery Power Supply to On-Chip Regulator.
44	VSS	S	Ground Reference for the Internal Voltage Regulators.
46	RESERVED		Reserved for High Voltage Output Only Functionality. This pin should be connected externally to the IO_VSS ground reference.
47	IO_VSS	S	Ground Reference for High Voltage Input/Output Pins.
48	LIN	I/O	LIN Serial Interface Input/Output Pin.

¹ I = input, O = output, S = supply.

TERMINOLOGY

Conversion Rate

The conversion rate specifies the rate at which an output result is available from the ADC, once the ADC has settled.

The Σ - Δ conversion techniques used on this part mean that while the ADC front-end signal is oversampled at a relatively high sample rate, a subsequent digital filter is employed to decimate the output to give a valid 16-bit data conversion result at output rates from 1 Hz to 8 kHz.

Note that when software switches from one input to another (on the same ADC), the digital filter must first be cleared and then allowed to average a new result. Depending on the configuration of the ADC and the type of filter, this can take multiple conversion cycles.

Integral Nonlinearity (INL)

Integral nonlinearity is the maximum deviation of any code from a straight line passing through the endpoints of the transfer function. The endpoints of the transfer function are zero scale, a point 0.5 LSB below the first code transition; and full scale, a point 0.5 LSB above the last code transition (111 . . . 110 to 111 . . . 111). The error is expressed as a percentage of full scale.

No Missing Codes

No missing codes is a measure of the differential nonlinearity of the ADC. The error is expressed in bits and specifies the number of codes (ADC results) as 2^N bits, where N = no missing codes, guaranteed to occur through the full ADC input range.

Offset Error

Offset error is the deviation of the first code transition ADC input voltage from the ideal first code transition.

Offset Error Drift

Offset error drift is the variation in absolute offset error with respect to temperature. This error is expressed as LSBs per °C.

Gain Error

Gain error is a measure of the span error of the ADC. It is a measure of the difference between the measured span and the ideal span between any two points in the transfer function.

Output Noise

Output noise is the standard deviation (or $1 \times \Sigma$) of ADC output codes distribution collected when the ADC input voltage is at a dc voltage. It is expressed as micro root mean square (μ rms).

The output or rms noise can be used to calculate the effective resolution of the ADC, as defined by the following equation:

$$\text{Effective Resolution} = \log_2(\text{Full-Scale Range}/\text{rms Noise}) \text{ bits}$$

The peak-to-peak noise is defined as the deviation of codes that fall within $6.6 \times \Sigma$ of the distribution of ADC output codes collected when the ADC input voltage is at dc. The peak-to-peak noise is, therefore, calculated as $6.6 \times$ the rms noise.

The peak-to-peak noise can be used to calculate the ADC (noise free, code) resolution for which there is no code flicker within a 6.6 sigma limit, as defined by the following equation:

$$\text{Noise Free Code Resolution} = \log_2(\text{Full-Scale Range}/\text{Peak-to-Peak Noise}) \text{ bits}$$

Table 8. Data Sheet Acronyms

Acronym	Definition
ADC	analog-to-digital converter
ARM	advanced RISC machine
ECU	electronic control unit
JTAG	joint test action group
LDO	low dropout
LIN	local interconnect network
LSB	least significant byte/bit
LVF	low voltage flag
MAC	multiplication accumulation
MCU	microcontroller
MMR	memory mapped register
MSB	most significant byte/bit
PID	protected identifier
PLL	phase-locked loop
POR	power-on reset
PSM	power supply monitor
rms	root mean square

THEORY OF OPERATION

The ADuC7032-8L is a complete system solution for battery monitoring in 12 V automotive applications. The device integrates all of the required features to precisely and intelligently monitor, process, and diagnose 12 V battery parameters, including battery current, voltage, and temperature, over a wide range of operating conditions.

Minimizing external system components, the device is powered directly from the 12 V battery. An on-chip, low dropout (LDO) regulator generates the supply voltage for the three integrated 16-bit ADCs. The ADCs precisely measure battery current, voltage, and temperature, which can be used to characterize the state of health and charge of a car battery.

A Flash/EE memory-based ARM7™ microcontroller (MCU) is also integrated on-chip and is used both to preprocess the acquired battery variables and to manage communications from the ADuC7032-8L to the main electronic control unit (ECU) via a local interconnect network (LIN) interface, which is integrated on-chip.

Both the MCU and the ADC subsystem can be individually configured to operate in normal or flexible power saving modes of operation.

In its normal operating mode, the MCU is clocked indirectly from an on-chip oscillator via the phase-locked loop (PLL) at a maximum clock rate of 20.48 MHz. In its power-saving operating modes, the MCU can be totally powered down, waking up only in response to an ADC conversion result ready, digital comparators, the wake-up timer, a power-on reset (POR), or an external serial communication event.

The ADC can be configured to operate in a normal (full-power) mode of operation, interrupting the MCU after various sample conversion events. The current channel features two low power modes: low power and low power plus, generating conversion results to a lower performance specification.

On-chip factory firmware supports in-circuit Flash/EE memory reprogramming via the LIN or JTAG serial interface ports, and nonintrusive emulation is supported via the JTAG interface. These features are incorporated into a low cost QuickStart™ Plus development system supporting the ADuC7032-8L.

The ADuC7032-8L operates directly from the 12 V battery supply and is fully specified over a temperature range of -40°C to +105°C. The ADuC7032-8L is functional, with degraded performance, at temperatures from 105°C to 125°C.

OVERVIEW OF THE ARM7TDMI® CORE

The ARM7 core is a 32-bit reduced instruction set computer (RISC), developed by ARM Ltd. The ARM7TDMI is a von Neumann-based architecture, which means that it uses a single 32-bit bus for instruction and data. The length of the data can be 8, 16, or 32 bits; and the length of the instruction word is either 16 bits or 32 bits, depending on the mode in which the core is operating.

The ARM7TDMI is an ARM7 core with four additional features, as listed in Table 9.

Table 9. ARM7TDMI Features

Feature	Description
T	Support for the Thumb® (16-bit) instruction set
D	Support for debug
M	Enhanced multiplier
I	Includes the EmbeddedICE™ module to support embedded system debugging

Thumb Mode (T)

An ARM® instruction is 32 bits long. The ARM7TDMI processor supports the Thumb instruction set, which has been compressed into 16 bits. Faster code execution from 16-bit memory and greater code density can be achieved by using the Thumb instruction set, which makes the ARM7TDMI core particularly suited for embedded applications.

However, Thumb mode has three limitations.

- Relative to ARM, Thumb code usually requires more instructions to perform that same task. Therefore, in most applications ARM code is best used for maximizing the performance of time-critical code.
- The Thumb instruction set does not include some instructions that are needed for exception handling. Therefore, ARM code may be required for exception handling.
- When an interrupt occurs, the core vectors to the interrupt location in memory and executes the code present at this address. It is required that the first command be in ARM code.

Multiplier (M)

The ARM7TDMI instruction set includes an enhanced multiplier, with four extra instructions that perform 32-bit × 32-bit multiplication with a 64-bit result and 32-bit × 32-bit multiplication-accumulation (MAC) with a 64-bit result.

EmbeddedICE (I)

The EmbeddedICE module provides integrated on-chip debug support for the ARM7TDMI. The EmbeddedICE module contains the breakpoint and watchpoint registers, which allow nonintrusive user code debugging. These registers are controlled through the JTAG test port.

When a breakpoint or watchpoint is encountered, the processor halts and enters debug state. Once in a debug state, the processor registers may be interrogated, as well as the Flash/EE, the SRAM, and the memory mapped registers.

ARM7 Exceptions

The ARM7 supports five types of exceptions, with a privileged processing mode associated with each type. The five types of exceptions follow:

- Normal interrupt or IRQ. It is provided to service general-purpose interrupt handling of internal and external events.
- Fast interrupt or FIQ. It is provided to service data transfer or a communication channel with low latency. FIQ has priority over IRQ.
- Memory abort (prefetch and data).
- Attempted execution of an undefined instruction.
- Software interrupt (SWI) instruction. It can be used to make a call to an operating system.

Typically, the programmer defines interrupts as IRQ; but for higher priority interrupts, the programmer can define interrupts as being of the FIQ type.

The priority of the above exceptions and vector addresses are shown in Table 10.

Table 10. Exception Priority

Priority	Exception	Vector Address
1	Hardware reset	0x00
2	Memory abort (data)	0x10
3	FIQ	0x1C
4	IRQ	0x18
5	Memory abort (prefetch)	0x0C
6	Software interrupt ¹	0x04
6	Undefined instruction ¹	0x04

¹ A software interrupt and an undefined instruction exception have the same priority and are mutually exclusive.

The exceptions in Table 10 are located from Address 0x00 to Address 0x1C, with a reserved location at 0x14. This location is required to be written with either 0x27011970 or the checksum of Page 0, excluding Location 0x14. If this is not done, user code is not executed, and LIN download mode is entered.

ARM Registers

The ARM7TDMI has 16 standard registers. R0 to R12 are used for data manipulation, R13 is the stack pointer, R14 is the link register, and R15 is the program counter that indicates the instruction currently being executed. The link register contains the address from which the user has branched, if the branch and link command was used, or the command during which an exception occurred.

The stack pointer (R13) contains the current location of the stack. Typically, on an ARM7TDMI, the stack starts at the top of the available RAM area and descends, using the area as required. A separate stack is defined for each exception. The size of each stack is user configurable and is dependent on the target application. On the ADuC7032-8L, the stack begins at 0x000417FC and descends.

When programming using a high level language such as C, it is necessary to ensure that the stack does not overflow. This is dependent on the performance of the compiler that is used.

When an exception occurs, some of the standard registers are replaced with registers specific to the exception mode. All exception modes have replacement banked registers for the stack pointer (R13) and the link register (R14), as represented in Figure 9. The FIQ mode has more registers (R8 to R12), supporting faster interrupt processing. With the increased number of noncritical registers, the interrupt can be processed without the need to save or restore these registers, reducing the response time of the interrupt handling process.

More information relative to the programmer's model and the ARM7TDMI core architecture can be found in ARM7TDMI technical and ARM architecture manuals available directly from ARM Ltd.

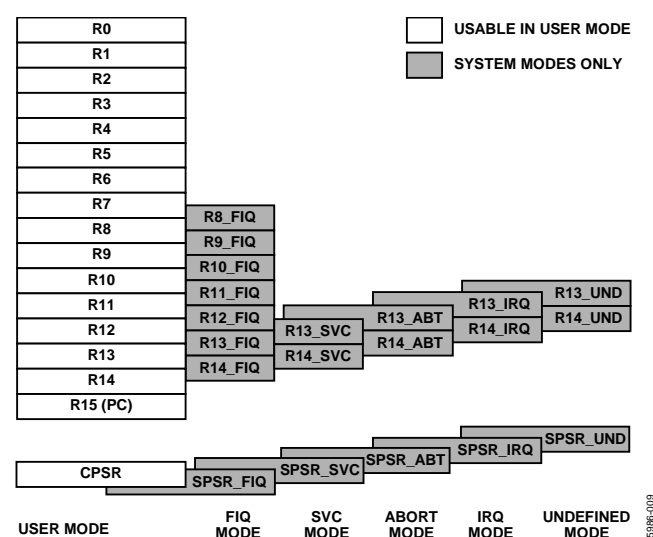

Figure 9. Register Organization

ADuC7032-8L

Interrupt Latency

- The worst-case latency for an FIQ consists of the following:
- The longest time the request can take to pass through the synchronizer
- Plus the time for the longest instruction to complete (the longest instruction is an LDM that loads all the registers, including the PC)
- Plus the time for the data abort entry
- Plus the time for FIQ entry

At the end of this time, the ARM7TDMI executes the instruction at 0x1C (FIQ interrupt vector address). The maximum total time is 50 processor cycles, or just over 2.44 μ s in a system using a continuous 20.48 MHz processor clock. The maximum IRQ latency calculation is similar, but it must allow for the fact that FIQ has higher priority and could delay entry into the IRQ handling routine for an arbitrary length of time. This time can be reduced to 42 cycles if the LDM command is not used; some compilers have an option to compile without using this command. Another option is to run the part in Thumb mode, where the time is reduced to 22 cycles.

The minimum latency for FIQ or IRQ interrupts is five cycles. It consists of the shortest time the request can take through the synchronizer, plus the time to enter the exception mode.

Note that the ARM7TDMI initially (first instruction) runs in ARM (32-bit) mode when an exception occurs. The user can immediately switch from ARM mode to Thumb mode, if required (for example, when executing interrupt service routines).

MEMORY ORGANIZATION

The ARM7 (a von Neumann architecture) MCU core sees memory as a linear array of 2^{32} byte locations. As shown in Figure 10, the ADuC7032-8L maps this memory into four distinct user areas, namely

- A remappable memory area
- An SRAM area
- A Flash/EE area
- A memory mapped register (MMR) area

The first 96 kB of this memory space is used as an area into which the on-chip Flash/EE or SRAM can be remapped. A second 4 kB area at the top of the memory map is used to locate the memory mapped registers (MMR), through which all on-chip peripherals are configured and monitored. The remaining two areas of memory are constituted as 6 kB of SRAM and 96 kB of on-chip Flash/EE memory. There are 94 kB of on-chip Flash/EE memory available to the user, and the remaining 2 kB are reserved for the on-chip kernel. These areas are described in more detail in the sections that follow.

Any access, either read or write, to an area not defined in the memory map results in a data abort exception.

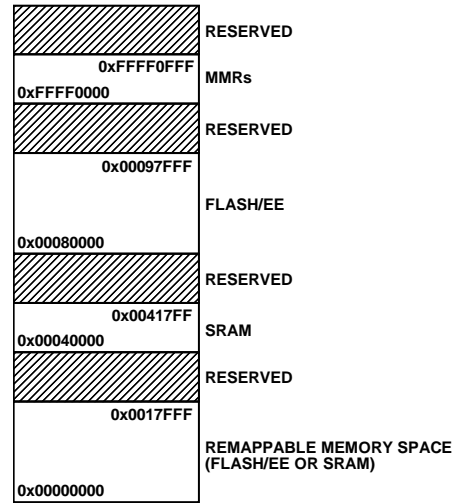

Figure 10. ADuC7032-8L Memory Map

Memory Format

The ADuC7032-8L memory organization is configured in little endian format: the least significant byte is located in the lowest byte address, and the most significant byte is located in the highest byte address.

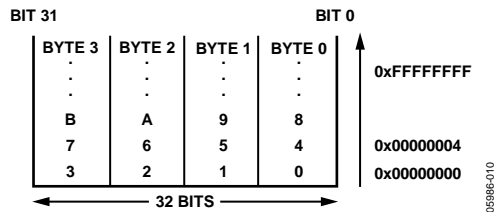

Figure 11. Little Endian Format

SRAM

The ADuC7032-8L features 6 kB of SRAM available to the user, organized as 1536 bits \times 32 bits, that is, 1536 words, that are located at 0x00040000. RAM space can be used as data memory and as a volatile program space.

ARM code can run directly from SRAM at full clock speed, given that the SRAM array is configured as a 32-bit wide memory array.

SRAM is read/write in 8-, 16-, and 32-bit segments.

Remap

The ARM exception vectors are all situated at the bottom of the memory array, from Address 0x00000000 to Address 0x00000020.

By default, after a reset, the Flash/EE memory is logically mapped to Address 0x00000000.

It is possible to logically remap the SRAM to Address 0x00000000 by setting Bit 0 of the SYSMAP0 MMR, which is located at 0xFFFF0220. To revert Flash/EE to Address 0x00000000, Bit 0 of SYSMAP0 is cleared.

It may be desirable to remap RAM to Address 0x00000000 to optimize the interrupt latency of the ADuC7032-8L, as code can be run in full 32-bit ARM mode and at the maximum core speed. It should be noted that when an exception occurs, the core defaults to ARM mode.

Remap Operation

When a reset occurs on the ADuC7032-8L, execution starts automatically in the factory-programmed internal configuration code. This so-called kernel is hidden and cannot be accessed by user code.

SYSMAP0 Register

Name: SYSMAP0

Address: 0xFFFF0220

Default Value: Updated by the kernel

Access: Read/write

Function: This 8-bit register allows user code to remap either RAM or Flash/EE space into the bottom of the ARM memory space, starting at Address 0x00000000.

Table 11. SYSMAP0 MMR Bit Designations

Bit	Description
7 to 1	Reserved. These bits are reserved and should be written as 0 by user code.
0	Remap Bit. Set by the user to remap the SRAM to 0x00000000. Cleared automatically after reset to remap the Flash/EE memory to 0x00000000.

If the ADuC7032-8L is in normal mode, it executes the power-on configuration routine of the kernel and then jumps to the reset vector, Address 0x00000000, to execute the user reset exception routine.

Because the Flash/EE is mirrored at the bottom of the memory array at reset, the reset routine must always be written in Flash/EE.

Precautions must be taken to execute the remap command from the absolute Flash/EE address, and not from the mirrored, remapped segment of memory, because this segment may be replaced by the SRAM. If a remap operation is executed while operating code from the mirrored location, prefetch/data aborts may occur; or the user may observe abnormal program operation.

This operation is reversible. The Flash/EE can be remapped to Address 0x00000000 by clearing Bit 0 of the SYSMAP0 MMR. Precautions must again be taken to execute the remap function from outside the mirrored area.

Any kind of reset logically remaps the Flash/EE memory to the bottom of the memory array.

ADuC7032-8L

RESET

There are four kinds of reset: external reset, power-on reset, watchdog reset, and software reset. The RSTSTA register indicates the source of the last reset and can be written by user code to initiate a software reset event. The bits in this register can be cleared to 0 by writing to the RSTCLR MMR at 0xFFFF0234.

The bit designations in RSTCLR mirror those of RSTSTA. These registers can be used during a reset exception service routine to identify the source of the reset. The implications of all four kinds of reset event are listed in Table 12.

Table 12. Device Reset Implications

Impact/Reset	Reset External Pins to Default State	Kernel Executed	Reset All External MMRs (Excluding RSTSTA)	Reset All High Voltage Indirect Registers	Peripherals Reset	RAM Valid ¹	RSTSTA (Status After Reset Event)
POR ¹	Yes	Yes	Yes	Yes	Yes	Yes/No ²	RSTSTA[0] = 1
Watchdog Reset	Yes	Yes	Yes	Yes	Yes	Yes	RSTSTA[1] = 1
Software Reset	Yes	Yes	Yes	Yes	Yes	Yes	RSTSTA[2] = 1
External Reset Pin	Yes	Yes	Yes	Yes	Yes	Yes	RSTSTA[3] = 1

¹RAM is valid except in the case of a reset following a LIN download.

²The impact of RAM is dependent on the contents of HVSTA[6] if LVF is enabled. When LVF is enabled using (HVCFG0[2]), RAM has not been corrupted by the POR reset mechanism if the LVF Status Bit HVSTA[6] = 1. See the Low Voltage Flag (LVF) section for more information.

RSTCLR Register

Name: RSTCLR

Address: 0xFFFF0234

Default Value: 0x00

Access: Write only

Function: This 8-bit write-only register clears the corresponding bit in RSTSTA.

RSTSTA Register

Name: RSTSTA

Address: 0xFFFF0230

Default Value: 0x01

Access: Read/write

Function: This 8-bit register indicates the source of the last reset event and can be written by user code to initiate a software reset.

Table 13. RSTCLR/RSTSTA MMR Bit Designations

Bit	Description
7 to 4	Not Used. These bits are not used and always read as 0.
3	External Reset. Set to 1 automatically when an external reset occurs. Cleared by setting the corresponding bit in RSTCLR.
2	Software Reset. ¹ Set to 1 by user code to generate a software reset. Cleared by setting the corresponding bit in RSTCLR.
1	Watchdog Timeout. Set to 1 automatically when a watchdog timeout occurs. Cleared by setting the corresponding bit in RSTCLR.
0	Power-On Reset. Set automatically when a power-on reset occurs. Cleared by setting the corresponding bit in RSTCLR.

¹ If the software reset bit in RSTSTA is set, any write to RSTCLR that does not clear this bit generates a software reset.

FLASH/EE MEMORY AND THE ADUC7032-8L

The ADuC7032-8L incorporates Flash/EE memory technology on-chip to provide the user with nonvolatile, in-circuit reprogrammable memory space.

Like EEPROM, Flash memory can be programmed in-system at the byte level, although it must first be erased, the erase being performed in page blocks. Thus, Flash memory is often and more correctly referred to as Flash/EE memory.

Overall, Flash/EE memory represents a step closer to the ideal memory device that includes nonvolatility, in-circuit programmability, high density, and low cost. Incorporated in the ADuC7032-8L, Flash/EE memory technology allows the user to update program code space in-circuit, without the need to replace one-time programmable (OTP) devices at remote operating nodes.

Flash/EE Memory

The total 96 kB of Flash/EE memory is organized as 48 kB × 16 bits. Of the 96 kB, 94 kB is user space, and 2 kB is reserved for boot loader/kernel space. The page size of this Flash/EE memory is 512 bytes. Typically, it takes the Flash/EE controller 20 ms to erase a page, and 50 μs to write a 16-bit word. These Flash/EE timings are independent of the MCU core clock.

There is 94 kB of Flash/EE memory available to the user as code and nonvolatile data memory. There is no distinction between data and program, because ARM code shares the same space. The real width of the Flash/EE memory is 16 bits, which means that in ARM mode (32-bit instruction), two accesses to the Flash/EE are necessary for each instruction fetch. When operating at speeds less than 20.48 MHz, the Flash/EE memory controller can transparently fetch the second 16-bit halfword (part of the 32-bit ARM operation code) within a single core clock period. Therefore, for speeds less than 20.48 MHz (that is, CD > 0), it is recommended that ARM mode be used. For 20.48 MHz operation (that is, CD = 0), it is recommended that Thumb mode be used.

The Flash/EE memory is physically located at Address 0x80000. Upon a hard reset, it is logically mapped to 0x00000000. The factory default contents of all Flash/EE memory locations is 0xFF. Flash/EE can be read in 8-, 16-, and 32-bit segments and written in segments of 16 bits. The Flash/EE is rated for 10,000 endurance cycles. This rating is based on the number of times that each individual halfword (16-bit location) is cycled, that is, erased and programmed. A redundancy scheme can be implemented in software to ensure greater than 10,000 cycles of endurance.

The user can also write data variables to the Flash/EE memory during run-time code execution, for example, for storing diagnostic battery parameter data.

It is possible to write to a single 16-bit location only twice between erases; that is, it is possible to walk bytes, not bits. If a location is written to more than twice, the contents of the Flash/EE page may be corrupted.

The 94 kB of Flash/EE memory can be programmed in-circuit, using a serial download mode via the LIN interface or the integrated JTAG port.

Serial Downloading (In-Circuit Programming)

The ADuC7032-8L facilitates code download via the LIN pin.

JTAG Access

The ADuC7032-8L features an on-chip JTAG debug port to facilitate code download and debug.

FLASH/EE CONTROL INTERFACE

The access to and control of the Flash/EE memory on the ADuC7032-8L is managed by an on-chip memory controller. The controller manages the Flash/EE memory as two separate blocks (Block 0 and Block 1).

Block 0 consists of the 32 kB Flash/EE memory mapped from 0x00090000 to 0x00097FFF (including the 2 kB kernel space that is reserved at the top of this block).

Block 1 consists of the 6 kB Flash/EE memory mapped from 0x00080000 to 0x0008FFFF.

Note that the MCU core can continue to execute code from one memory block while an active erase or program cycle is being carried out on the other block. If a command operates on the same block as the code currently executing, the core is halted until the command is completed. This also applies to code execution.

User code, LIN, and JTAG programming use the Flash/EE control interface, which consists of the following MMRs:

- FEExSTA (x = 0 or 1): read-only register that reflects the status of the Flash/EE memory control interface
- FEExMOD (x = 0 or 1): sets the operating mode of the Flash/EE memory control interface
- FEExCON (x = 0 or 1): 8-bit command register; the commands are interpreted as described in Table 14.
- FEExDAT (x = 0 or 1): 16-bit data register
- FEExADR (x = 0 or 1): 16-bit address register
- FEExSIG (x = 0 or 1): holds the 24-bit code signature as a result of the signature command being initiated

ADuC7032-8L

- FEE_xHID (x = 0 or 1) is a protection MMR that controls read- and write-protection of the Flash/EE memory code space. If previously configured via the FEE_xPRO register, FEE_xHID may require a software key to enable access.
- FEE_xPRO (x = 0 or 1) is a buffer of the FEE_xHID register, which is used to store the FEE_xHID value so it is automatically downloaded to the FEE_xHID registers on subsequent reset and power-on events.

Note that user software must ensure that the Flash/EE controller has completed any erase or write cycle before the PLL is powered down. If the PLL is powered down before an erase or write cycle has completed, the Flash/EE page or byte may be corrupted. The following sections describe in detail the bit designations of each of the Flash/EE control MMRs.

FEE0CON and FEE1CON Registers

Name: FEE0CON and FEE1CON

Address: 0xFFFF0E08 and 0xFFFF0E88

Default Value (Both Registers): 0x07

Access: Read/write

Function: These 8-bit registers are written by user code to control the operating modes of the Flash/EE memory controllers for Block 0 (32 kB) and Block 1 (64 kB).

Table 14. Command Codes in FEE0CON and FEE1CON

Code	Command	Description ¹
0x00 ²	Reserved	Reserved. This command should not be written by user code.
0x01 ²	Single read	Load FEE _x DAT with the 16-bit data indexed by FEE _x ADR.
0x02 ²	Single write	Write FEE _x DAT at the address pointed by FEE _x ADR. This operation takes 50 μs.
0x03 ²	Erase-write	Erase the page indexed by FEE _x ADR and write FEE _x DAT at the location pointed by FEE _x ADR. This operation takes 20 ms.
0x04 ²	Single verify	Compare the contents of the location pointed by FEE _x ADR to the data in FEE _x DAT. The result of the comparison is returned in FEE _x STA Bit 1.
0x05 ²	Single erase	Erase the page indexed by FEE _x ADR.
0x06 ²	Mass erase	Erase Block 0 (30 kB) or Block 1 (64 kB) of user space. The 2 kB kernel is protected. This operation takes 1.2 sec. To prevent accidental execution, a command sequence is required to execute this instruction. This sequence is described in the Command Sequence for Executing a Mass Erase section.
0x07		Default command.
0x08	Reserved	Reserved. This command should not be written by user code.
0x09	Reserved	Reserved. This command should not be written by user code.
0x0A	Reserved	Reserved. This command should not be written by user code.
0x0B	Signature	FEE0CON. This command results in a 24-bit LFSR-based signature being generated and loaded into FEE0SIG. If FEE0ADR is less than 0x97800, this command results in a 24-bit LFSR-based signature of the user code space from the page specified in FEE0ADR upwards, including the kernel, security bits, and Flash/EE key. If FEE0ADR is greater than 0x97800, the kernel and manufacturing data are signed. FEE1CON. This command results in a 24-bit LFSR-based signature being generated, beginning at FEE1ADR and ending at the end of the 64 kB block, and loaded into FEE1SIG. The last page of this block is not included in the sign generation.
0x0C	Protect	This command can be run only once. The value of FEE _x PRO is saved and can be removed only with a mass erase (0x06) or with the software protection key.
0x0D	Reserved	Reserved. This command should not be written by user code.
0x0E	Reserved	Reserved. This command should not be written by user code.
0x0F	Ping	No operation, interrupt generated.

¹ x in the register names designates 0 or 1 for Flash/EE Block 0 or Flash/EE Block 1.

² The FEE_xCON always reads 0x07 immediately after execution of any of these commands.

Command Sequence for Executing a Mass Erase

Because of the significance of the mass erase command, a specific code sequence must be executed to initiate this operation.

1. Set Bit 3 in FEE_xMOD.
2. Write 0xFFC3 in FEE_xADR.
3. Write 0x3CFF in FEE_xDAT.
4. Run the mass erase command 0x06 in FEE_xCON.

To run the mass-erase command via FEE0CON, write protection on the lower 64 kB must be disabled; that is, FEE1HID and FEE1PRO are set to 0xFFFFFFFF. This is accomplished by first removing the protection or by erasing the lower 64 kB first.

Command Sequence Example

The command sequence for executing a mass erase is illustrated in the following example:

```
Int a = FEExSTA;           // Ensure FEExSTA is cleared
FEExMOD = 0x08;
FEExADR = 0xFFC3;
FEExDAT = 0x3CFF;
FEExCON = 0x06;           // Mass-Erase command
while (FEExSTA & 0x04){} // Wait for command to finish
```

FEE0STA and FEE1STA Registers

Name: FEE0STA and FEE1STA

Address: 0xFFFF0E00 and 0xFFFF0E80

Default Value (Both Registers): 0x20

Access: Read only

Function: These 8-bit read-only registers can be read by user code and reflect the current status of the Flash/EE memory controllers.

Table 15. FEE0STA and FEE1STA MMR Bit Designations

Bit	Description ¹
15 to 4	Not Used. These bits are not used and are always read as 0.
3	Flash Interrupt Status Bit. Set automatically when an interrupt occurs, that is, when a command is complete and the Flash/EE interrupt enable bit in the FEE _x MOD register is set. Cleared automatically when the FEE _x STA register is read by user code.
2	Flash/EE Controller Busy. Set automatically when the Flash/EE controller is busy. Cleared automatically when the controller is not busy.
1	Command Fail. Set automatically when a command written to FEE _x CON completes unsuccessfully. Cleared automatically when the FEE _x STA register is read by user code.
0	Command Successful. Set automatically by MCU when a command is completed successfully. Cleared automatically when the FEE _x STA register is read by user code.

¹ x is 0 or 1 to designate Flash/EE Block 0 or Flash/EE Block 1.

FEE0ADR and FEE1ADR Registers

Name: FEE0ADR and FEE1ADR

Address: 0xFFFF0E10 and 0xFFFF0E90

Default Value: Nonzero (FEE0ADR), 0x0000 (FEE1ADR)

Access: Read/write

Function: This 16-bit register dictates the address acted upon by any Flash/EE command executed via FEE_xCON.

FEE0DAT and FEE1DAT Registers

Name: FEE0DAT and FEE1DAT

Address: 0xFFFF0E0C and 0xFFFF0E8C

Default Value (Both Registers): 0x0000

Access: Read/write

Function: This 16-bit register contains the data either read from or to be written to the Flash/EE memory controllers.

ADuC7032-8L

FEE0MOD and FEE1MOD Registers

Name: FEE0MOD and FEE1MOD

Address: 0xFFFF0E04 and 0xFFFF0E84

Default Value (Both Registers): 0x00

Access: Read/write

Function: These registers are written by user code to configure the mode of operation of the Flash/EE memory controllers.

Table 16. FEE0MOD and FEE1MOD MMR Bit Designations

Bit	Description ¹
15 to 7	Not Used. These bits are reserved for future functionality and should be written as 0 by user code.
6 to 5	Flash/EE Security Lock Bits. These bits must be written as [6:5] = 10 to complete the Flash security protect sequence.
4	Flash/EE Controller Command Complete Interrupt Enable. Set to 1 by user code to enable the Flash/EE controller to generate an interrupt upon completion of a Flash/EE command. Cleared to disable the generation of a Flash/EE interrupt upon completion of a Flash/EE command.
3	Flash/EE Erase/Write Enable. Set by user code to enable the Flash/EE erase and write access via FEExCON. Cleared by user code to disable the Flash/EE erase and write access via FEExCON.
2	Reserved. Should be written as 0.
1	Flash/EE Controller Abort Enable. Set to 1 by user code to enable the Flash/EE controller abort functionality.
0	Reserved. Should be written as 0.

¹ x is 0 or 1 to designate Flash/EE Block 0 or Flash/EE Block 1.

FLASH/EE MEMORY SECURITY

The 94 kB of Flash/EE memory available to the user can be read-protected and write-protected using the FEE0HID and FEE1HID registers.

In Block 0, the FEE0HID MMR protects the 30 kB of Flash/EE memory. Bit 0 to Bit 28 of this register protect Page 0 to Page 57 from writing. Each bit protects two pages, that is, 1 kB. Bit 29 to Bit 30 protect Page 58 and Page 59, respectively; that is, each bit write-protects a single page of 512 bytes. The MSB of this register (Bit 31) protects Block 0 from being read through JTAG.

The FEE0PRO register mirrors the bit definitions of the FEE0HID MMR. The FEE0PRO MMR allows user code to lock the protection or security configuration of the Flash/EE memory so that the protection configuration is automatically loaded on subsequent power-on or reset events.

This flexibility allows the user to set and test protection settings temporarily using the FEE0HID MMR and subsequently lock the required protection configuration (using FEE0PRO) when shipping protection systems into the field.

In Block 1 (64 kB), the FEE1HID MMR protects the 64 kB of Flash/EE memory. Bit 0 to Bit 29 of this register protect Page 0 to Page 119 from writing. Each bit protects four pages, that is, 2 kB. Bit 30 protects Page 120 to Page 127; that is, Bit 30 write-protects eight pages of 512 bytes. The MSB of this register (Bit 31) protects Flash/EE Block 1 from being read through JTAG.

As with Block 0, the FEE1PRO register mirrors the bit definitions of the FEE1HID MMR. The FEE1PRO MMR allows user code to lock the protection or security configuration of the Flash/EE memory so that the protection configuration is automatically loaded on subsequent power-on or reset events.

Block 0, Flash/EE Memory Protection Registers**Name:** FEE0HID and FEE0PRO**Address:** 0xFFFF0E20 (for FEE0HID) and 0xFFFF0E1C (for FEE0PRO)**Default Value (Both Registers):** 0xFFFFFFFF (for FEE0HID) and 0x00000000 (for FEE0PRO)**Access:** Read/write**Function:** These registers are written by user code to configure the protection of the Flash/EE memory.**Table 17. FEE0HID and FEE0PRO MMR Bit Designations**

Bit	Description
31	Read Protection Bit. Cleared by the user to protect the 32 kB Flash/EE block code via JTAG read access. Set by the user to allow reading of the 32 kB Flash/EE block code via JTAG read access.
30	Write-Protection Bit. Set by user code to unprotect Page 59. Cleared by user code to write-protect Page 59.
29	Write-Protection Bit. Set by user code to unprotect Page 58. Cleared by user code to write-protect Page 58.
28 to 0	Write-Protection Bits. When set by user code, these bits unprotect Page 0 to Page 57 of the 30 kB Flash/EE code memory. Each bit write-protects two pages, and each page consists of 512 bytes. When cleared by user code, these bits write-protect Page 0 to Page 57 of the 30 kB Flash/EE code memory. Each bit write-protects two pages, and each page consists of 512 bytes.

Block 1, Flash/EE Memory Protection Registers**Name:** FEE1HID and FEE1PRO**Address:** 0xFFFF0EA0 (for FEE1HID) and 0xFFFF0E9C (for FEE1PRO)**Default Value (Both Registers):** 0xFFFFFFFF (for FEE1HID) and 0x00000000 (for FEE1PRO)**Access:** Read/write**Function:** These registers are written by user code to configure the protection of the Flash/EE memory.**Table 18. FEE1HID and FEE1PRO MMR Bit Designations**

Bit	Description
31	Read-Protection Bit. Cleared by the user to protect the 64 kB Flash/EE block code via JTAG read access. Set by the user to allow reading of the 64 kB Flash/EE block code via JTAG read access.
30	Write-Protection Bit. When set by user code, this bit protects Page 120 to Page 127 of the 64 kB Flash/EE code memory. This bit write-protects eight pages, and each page consists of 512 bytes. When cleared by user code, this bit write-protects Page 120 to Page 127 of the 64 kB Flash/EE code memory. This bit write-protects eight pages, and each page consists of 512 bytes.
29 to 0	Write-Protection Bits. When set by user code, these bits unprotect Page 0 to Page 119 of the 64 kB Flash/EE code memory. Each bit write-protects four pages, and each page consists of 512 bytes. When cleared by user code, these bits write-protect Page 0 to Page 119 of the 64 kB Flash/EE code memory. Each bit write-protects two pages, and each page consists of 512 bytes.

In summary, there are three levels of memory protection:

- Temporary protection can be set and removed by writing directly into the FEE_xHID MMR. This register is volatile; therefore, protection is in place only while the part remains powered on. Protection is not reloaded after a power cycle.
- Keyed permanent protection can be set via FEE_xPRO, which is used to lock the protection configuration. The software key used at the start of the required FEE_xPRO write sequence is saved once and must subsequently be used for any subsequent access to the FEE_xHID or FEE_xPRO MMRs. A mass erase sets the key back to 0xFFFF but also erases the entire user code space.
- Permanent protection can be set via FEE_xPRO, similarly to keyed permanent protection. The only difference is that the software key used is 0xDEADDEAD. Once the FEE_xPRO write sequence is saved, only a mass erase sets the key back to 0xFFFFFFFF. This mass erase also erases the entire user code space.

Sequence Example

The sequence to write the key and set permanent protection is illustrated in the following example, which protects writing Page 4 and Page 5 of the Flash/EE:

```
FEExPRO = 0xFFFFFFFFB;      // Protect Page 4 and Page 5
FEExADR = 0x66BB;          // 32-bit key value Bits[31:16]
FEExDAT = 0xAA55;          // 32-bit key value Bits[15:0]
FEExMOD = 0x0048;         // Lock security sequence
FEExCON = 0x0C;           // Write key command
while (FEExSTA & 0x04){} // Wait for command to finish
```

Sequence to Write the Key and Set Permanent Protection

1. Write in FEE_xPRO corresponding to the pages to be protected.
2. Write the new (user-defined) 32-bit key in FEE_xADR Bits[31:16] and FEE_xDAT Bits[15:0].
3. Write 1,0 in FEE_xMOD Bits[6:5] and set FEE_xMOD Bit 3.
4. Run the write key command 0x0C in FEE_xCON.

FLASH/EE MEMORY RELIABILITY

The Flash/EE memory array on the part is fully qualified for two key Flash/EE memory characteristics: Flash/EE memory cycling endurance and Flash/EE memory data retention.

Endurance quantifies the ability of the Flash/EE memory to be cycled through many program, read, and erase cycles. A single endurance cycle is composed of four independent, sequential events, defined as follows:

1. Initial page erase sequence
2. Read/verify sequence
3. Byte program sequence
4. Second read/verify sequence

In reliability qualification, every halfword (16-bits wide) location of the three pages (top, middle, and bottom) in the Flash/EE memory is cycled 10,000 times from 0x0000 to 0xFFFF. As shown in Table 1, the Flash/EE memory endurance qualification of the parts is carried out in accordance with JEDEC Retention Lifetime Specification A117. The results allow the specification of a minimum endurance figure over supply and temperature of 10,000 cycles.

Retention quantifies the ability of the Flash/EE memory to retain its programmed data over time. Again, the parts are qualified in accordance with the formal JEDEC Retention Lifetime Specification A117 at a specific junction temperature ($T_J = 85^\circ\text{C}$). As part of this qualification procedure, the Flash/EE memory is cycled to its specified endurance limit, described previously, before data retention is characterized. This means that the Flash/EE memory is guaranteed to retain its data for its fully specified retention lifetime every time the Flash/EE memory is reprogrammed. Also, note that retention lifetime, based on an activation energy of 0.6 eV, derates with T_J , as shown in Figure 12.

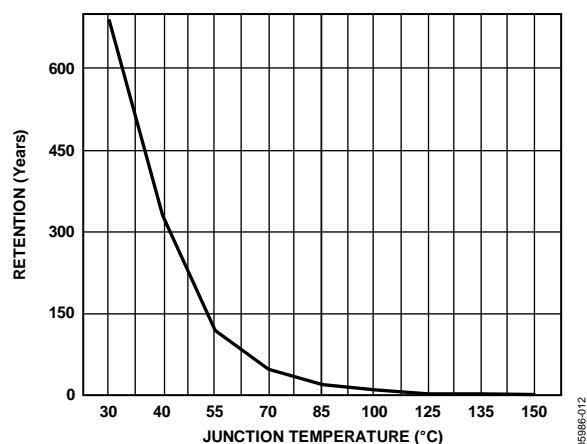

Figure 12. Flash/EE Memory Data Retention

CODE EXECUTION TIME FROM SRAM AND FLASH/EE

This section describes SRAM and Flash/EE memory access times during execution for applications where execution time is critical.

Execution from SRAM

Fetching instructions from SRAM takes one clock cycle. However, if the instruction involves reading or writing data to memory, one or two extra cycles must be added. If the data is in SRAM, one extra cycle is needed. If the data is in Flash/EE, two extra cycles are needed to get the 32-bit data from Flash/EE.

A control flow instruction (for example, a branch instruction) takes one cycle to fetch and two cycles to fill the pipeline with the new instructions.

Execution from Flash/EE

In Thumb mode, where instructions are 16 bits, one cycle is needed to fetch any instruction.

In ARM mode, with $CD = 0$, two cycles are needed to fetch the 32-bit instructions. With $CD > 0$, no extra cycles are required for the fetch because the Flash/EE memory continues to be clocked at full speed. In addition, some dead time is needed before accessing data for any value of CD bits.

Timing is identical in both modes when executing instructions that involve using the Flash/EE for data memory. If the instruction to be executed is a control flow instruction, an extra cycle is needed to decode the new address of the program counter, and then four cycles are needed to fill the pipeline if $CD = 0$.

A data processing instruction involving only the core register does not require any extra clock cycles. Data transfer instructions are more complex and are summarized in Table 19.

Table 19. Typical Execution Cycles in ARM/Thumb Mode

Instruction	Fetch Cycle	Dead Time	Data Access
LD	2/1	1	2
LDH	2/1	1	1
LDM/POP	2/1	N	$2 \times N$
STR	2/1	1	$2 \times 50 \mu\text{s}$
STRH	2/1	1	$50 \mu\text{s}$
STM/PUSH	2/1	N	$2 \times N \times 50 \mu\text{s}$

With $1 < N \leq 16$, N is the number of registers to load or store in the multiple load/store instruction.

By default, Flash/EE code execution is suspended during any Flash/EE erase or write cycle. A page (512 bytes) erase cycle takes 20 ms, and a write (16 bits) word command takes $50 \mu\text{s}$. However, the Flash/EE memory controller allows erase/write cycles to be aborted if the ARM core receives an enabled interrupt during the current Flash/EE erase/write cycle. The ARM7 can, therefore, immediately service the interrupt and then return to repeat the Flash/EE command. The abort operation typically takes 10 clock cycles. If the abort operation is not feasible, it is possible to run Flash/EE memory programming code and the relevant interrupt routines from SRAM, allowing the core to service the interrupt immediately.

ADuC7032-8L

ADUC7032-8L KERNEL

The ADuC7032-8L features an on-chip kernel resident in the top 2 kB of the Flash/EE code space. After any reset event, this kernel copies the factory-calibrated data from the manufacturing data space into the various on-chip peripherals. The peripherals calibrated by the kernel are

- PSM (power supply monitor)
- Precision oscillator
- Low power oscillator
- REG_AVDD/REG_DVDD
- Low power voltage reference
- Normal mode voltage reference
- Current ADC (offset and gain)
- Voltage ADC (offset and gain)
- Temperature ADC (offset and gain)

User MMRs that can be modified by the kernel and differ from their POR default values are

- R0 to R15
- GP0CON/GP2CON
- SYSCHK
- ADCMDE/ADC0CON
- FEE0ADR/FEE0CON/FEE0SIG
- HVDAT/HVCON
- HVCFG0/HVCFG1
- T3LD

The ADuC7032-8L also features an on-chip LIN downloader.

Figure 13 is a flow chart showing the execution of the kernel. The current revision of the kernel can be derived from SYSSER1, as described in Table 96.

For the duration of kernel execution, the watchdog timer is active with a timeout period of 30 ms, which ensures that the ADuC7032-8L is reset if an error occurs in the kernel. The watchdog timer is disabled once the kernel code is exited.

Normal kernel execution time, excluding LIN download, is approximately 5 ms. It is possible to enter and leave LIN download mode only via a reset.

SRAM is not modified during normal kernel execution. SRAM is modified during LIN download kernel execution.

Note that, even with NTRST = 0, user code is not executed unless Address 0x14 contains either 0x27011970 or the checksum of Page 0, excluding Address 0x14. If Address 0x14 does not contain this information, user code is not executed and LIN download mode is entered.

With NTRST = 1, user code is always executed.

During kernel execution, JTAG access is disabled.

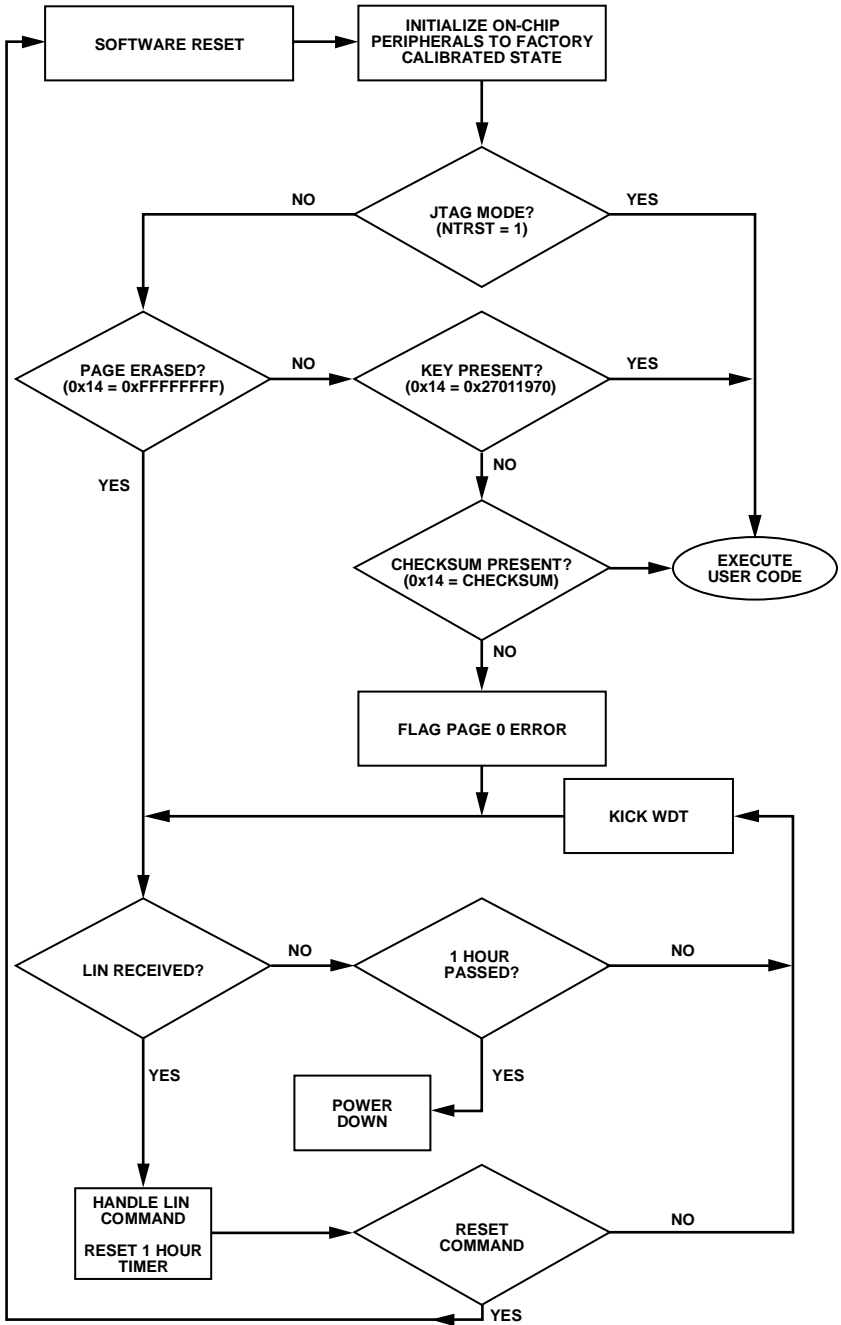

06986-013

Figure 13. ADuC7032-8L Kernel Flow Chart

ADuC7032-8L

MEMORY MAPPED REGISTERS

The memory mapped register (MMR) space is mapped into the top 4 kB of the MCU memory space and accessed by indirect addressing, load, and store commands through the ARM7 banked registers. An outline of the memory mapped register bank of the ADuC7032-8L is shown in Figure 14.

The MMR space provides an interface between the CPU and all on-chip peripherals. All registers except the ARM7 core registers (described in the ARM Registers section) reside in the MMR area.

As seen in the Complete MMR Listing section (Table 20 to Table 30), the MMR data widths vary from one byte (eight bits) to four bytes (32 bits). The ARM7 core can access any of the MMRs (single-byte or multiple-byte width registers) with a 32-bit read or write access.

The resultant read, for example, is aligned per the little endian format described in the Memory Format section. However, errors result if the ARM7 core tries to access 4-byte (32-bit) MMRs with a 16-bit access. In the case of a (16-bit) write access to a 32-bit MMR, the (upper) 16 most significant bits are written as 0s. More obviously, in the case of a 16-bit read access to a 32-bit MMR, only 16 of the MMR bits can be read.

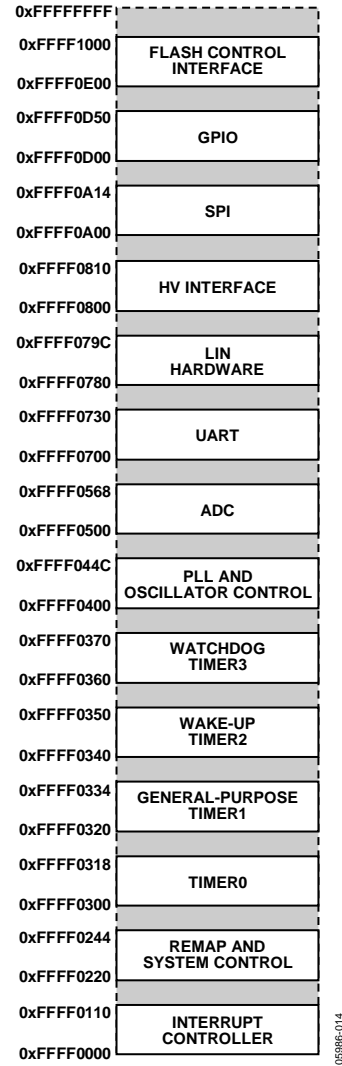

Figure 14. Top Level MMR Map

COMPLETE MMR LISTING**Table 20. IRQ Address Base = 0xFFFF0000**

Address	Name	Byte	Access Type	Default Value	Description
0x0000	IRQSTA	4	R	0x00000000	Active IRQ Source.
0x0004	IRQSIG ¹	4	R		Current State of All IRQ Sources (Enabled and Disabled).
0x0008	IRQEN	4	RW	0x00000000	Enabled IRQ Sources.
0x000C	IRQCLR	4	W		MMR Used to Disable IRQ Sources.
0x0010	SWICFG	4	W		Software Interrupt Configuration MMR.
0x0100	FIQSTA	4	R	0x00000000	Active IRQ Source.
0x0104	FIQSIG ¹	4	R		Current State of All IRQ Sources (Enabled and Disabled).
0x0108	FIQEN	4	RW	0x00000000	Enabled IRQ Sources.
0x010C	FIQCLR	4	W		MMR Used to Disable IRQ Sources.

¹ Depends on the level on the GP0, GP5, GP7, and GP8 external interrupt pins.

Table 21. System Control Address Base = 0xFFFF0200

Address	Name	Byte	Access Type	Default Value	Description
0x0220	SYMAP0	1	RW		REMAP Control Register.
0x0230	RSTSTA	1	RW	0x01	Reset Status MMR.
0x0234	RSTCLR	1	W		RSTSTA Clear MMR.
0x0238	SYSSER0 ¹	4	RW		SYSTEM Serial Number 0.
0x023C	SYSSER1 ¹	4	RW		SYSTEM Serial Number 1.
0x0240	SYSCHK ¹	4	RW		Kernel Checksum.

¹ Updated by kernel.

Table 22. Timer Address Base = 0xFFFF0300

Address	Name	Byte	Access Type	Default Value	Description
0x0300	TOLD	2	RW	0x0000	Timer0 Load Register.
0x0304	TOVAL0	2	R	0x0000	Timer0 Value Register 0.
0x0308	TOVAL1	4	R	0x00000000	Timer0 Value Register 1.
0x030C	TOCON	4	RW	0x00000000	Timer0 Control MMR.
0x0310	TOCLR1	1	W		Timer0 Interrupt Clear Register.
0x0314	TOCAP	2	RW	0x0000	Timer0 Capture Register.
0x0320	T1LD	4	RW	0x00000000	Timer1 Load Register.
0x0324	T1VAL	4	R	0xFFFFFFFF	Timer1 Value Register.
0x0328	T1CON	4	RW	0x01000000	Timer1 Control MMR.
0x032C	T1CLR1	1	W	0xFF	Timer1 Interrupt Clear Register.
0x0330	T1CAP	4	RW	0x00000000	Timer1 Capture Register.
0x0340	T2LD	4	RW	0x00000000	Timer2 Load Register.
0x0344	T2VAL	4	R	0xFFFFFFFF	Timer2 Value Register.
0x0348	T2CON	2	RW	0x0000	Timer2 Control MMR.
0x034C	T2CLR1	1	W		Timer2 Interrupt Clear Register.
0x0360	T3LD ¹	2	RW		Timer3 Load Register.
0x0364	T3VAL ¹	2	R		Timer3 Value Register.
0x0368	T3CON ¹	2	RW		Timer3 Control MMR.
0x036C	T3CLR1	1	W		Timer3 Interrupt Clear Register.

¹ Updated by kernel.

ADuC7032-8L

Table 23. PLL Base Address = 0xFFFF0400

Address	Name	Byte	Access Type	Default Value	Description
0x0400	PLLSTA	4	R		PLL Status MMR.
0x0404	POWKEY0	4	W		POWCON Prewrite Key.
0x0408	POWCON	1	RW	0x79	Power Control and Core Speed Control Register.
0x040C	POWKEY1	4	W		POWCON Postwrite Key.
0x0410	PLLKEY0	4	W		PLLCON Prewrite Key.
0x0414	PLLCON	1	RW	0x00	PLL Clock Source Selection MMR.
0x0418	PLLKEY1	4	W		PLLCON Postwrite Key.
0x042C	OSC0TRM	1	RW	0xX8	Low Power Oscillator Trim Bits MMR.
0x0440	OSC0CON	1	RW	0x00	Low Power Oscillator Calibration Control MMR.
0x0444	OSC0STA	1	R	0x00	Low Power Oscillator Calibration Status MMR.
0x0448	OSC0VAL0	2	R	0x0000	Low Power Oscillator Calibration Counter 0 MMR.
0x044C	OSC0VAL1	2	R	0x0000	Low Power Oscillator Calibration Counter 1 MMR.

Table 24. ADC Base Address = 0xFFFF0500

Address	Name	Byte	Access Type	Default Value	Description
0x0500	ADCSTA	2	R	0x0000	ADC Status MMR.
0x0504	ADCMSKI	1	RW	0x00	ADC Interrupt Source Enable MMR.
0x0508	ADCMDE	1	RW	0x00	ADC Mode Register.
0x050C	ADC0CON	2	RW	0x0002	Current ADC Control MMR.
0x0510	ADC1CON	2	RW	0x0000	Voltage ADC Control MMR.
0x0514	ADC2CON	2	RW	0x0000	Temperature ADC Control MMR.
0x0518	ADCFLT	2	RW	0x0007	ADC Filter Control MMR.
0x051C	ADCCFG	1	RW	0x00	ADC Configuration MMR.
0x0520	ADC0DAT	2	R	0x0000	Current ADC Result MMR.
0x0524	ADC1DAT	2	R	0x0000	Voltage ADC Result MMR.
0x0528	ADC2DAT	2	R	0x0000	Temperature ADC Result MMR.
0x052C	ADCFIFO	4	R		Current/Voltage Result FIFO.
0x0530	ADC0OF ¹	2	RW		Current ADC Offset MMR.
0x0534	ADC1OF ¹	2	RW		Voltage ADC Offset MMR.
0x0538	ADC2OF ¹	2	RW		Temperature ADC Offset MMR.
0x053C	ADC0GN ¹	2	RW		Current ADC Gain MMR.
0x0540	ADC1GN ¹	2	RW		Voltage ADC Gain MMR.
0x0544	ADC2GN ¹	2	RW		Temperature ADC Gain MMR.
0x0548	ADC0RCL	2	RW	0x0001	Current ADC Result Count Limit.
0x054C	ADC0RCV	2	R	0x0000	Current ADC Result Count Value.
0x0550	ADC0TH	2	RW	0x0000	Current ADC Result Threshold.
0x0554	ADC0TCL	1	RW	0x01	Current ADC Result Threshold Count Limit.
0x0558	ADC0THV	1	R	0x00	Current ADC Result Threshold Count Limit Value.
0x055C	ADC0ACC	4	R	0x00000000	Current ADC Result Accumulator.
0x0560	ADC0ATH	4	RW	0x00000000	Current ADC Result Accumulator Threshold.
0x057C	ADCREF ¹	2	RW		Low Power Mode Voltage Reference Scaling Factor.

¹ Updated by kernel.

Table 25. UART Base Address = 0xFFFF0700

Address	Name	Byte	Access Type	Default Value	Description
0x0700	COMTX	1	W	0x00	UART Transmit Register.
	COMRX	1	R		UART Receive Register.
	COMDIV0	1	RW		UART Standard Baud Rate Generator Divisor Value 0.
0x0704	COMIEN0	1	RW	0x00	UART Interrupt Enable MMR 0.
	COMDIV1	1	RW		UART Standard Baud Rate Generator Divisor Value 1.
0x0708	COMIID0	1	R	0x01	UART Interrupt Identification 0.
0x070C	COMCON0	1	RW	0x00	UART Control Register 0.
0x0710	COMCON1	1	RW	0x00	UART Control Register 1.
0x0714	COMSTA0	1	R	0x60	UART Status Register 0.
0x072C	COMDIV2	2	RW	0x0000	UART Fractional Divider MMR.

Table 26. LIN Hardware Sync Base Address = 0xFFFF0780

Address	Name	Byte	Access Type	Default Value	Description
0x0780	LHSSTA	1	R	0x00	LHS Status MMR.
0x0784	LHSCON0	2	RW	0x0000	LHS Control MMR 0.
0x0788	LHSVAL0	2	RW	0x0000	LHS Timer0 MMR.
0x078C	LHSCON1	1	RW	0x32	LHS Control MMR 1.
0x0790	LHSVAL1	1.5	RW	0x0000	LHS Timer1 MMR.

Table 27. High Voltage Interface Base Address = 0xFFFF0800

Address	Name	Byte	Access Type	Default Value	Description
0x0804	HVCON ¹	1	RW		High Voltage Interface Control MMR.
0x080C	HVDAT ¹	2	RW		High Voltage Interface Data MMR.

¹ Updated by kernel.

Table 28. SPI Base Address = 0xFFFF0A00

Address	Name	Byte	Access Type	Default Value	Description
0x0A00	SPISTA	1	R	0x00	SPI Status MMR.
0x0A04	SPIRX	1	R	0x00	SPI Receive MMR.
0x0A08	SPITX	1	W	0x00	SPI Transmit MMR.
0x0A0C	SPIDIV	1	RW	0x1B	SPI Baud Rate Select MMR.
0x0A10	SPICON	2	RW	0x0000	SPI Control MMR.

Table 29. GPIO Base Address = 0xFFFF0D00

Address	Name	Byte	Access Type	Default Value	Description
0x0D00	GP0CON	4	RW	0x11100000	GPIO Port 0 Control MMR.
0x0D04	GP1CON	4	RW	0x10000000	GPIO Port 1 Control MMR.
0x0D08	GP2CON	4	RW	0x01000000	GPIO Port 2 Control MMR.
0x0D20	GP0DAT ¹	4	RW	0x000000XX	GPIO Port 0 Data Control MMR.
0x0D24	GP0SET ¹	4	W		GPIO Port 0 Data Set MMR.
0x0D28	GP0CLR ¹	4	W		GPIO Port 0 Data Clear MMR.
0x0D30	GP1DAT ¹	4	RW	0x000000XX	GPIO Port 1 Data Control MMR.
0x0D34	GP1SET ¹	4	W		GPIO Port 1 Data Set MMR.
0x0D38	GP1CLR ¹	4	W		GPIO Port 1 Data Clear MMR.
0x0D40	GP2DAT ¹	4	RW	0x000000XX	GPIO Port 2 Data Control MMR.
0x0D44	GP2SET ¹	4	W		GPIO Port 2 Data Set MMR.
0x0D48	GP2CLR ¹	4	W		GPIO Port 2 Data Clear MMR.

¹ Depends on the level on the external GPIO pins.

ADuC7032-8L

Table 30. Flash/EE Base Address = 0xFFFF0300

Address	Name	Byte	Access Type	Default Value	Description
0x0E00	FEE0STA	1	R	0x20	Flash/EE Status MMR.
0x0E04	FEE0MOD	2	RW	0x00	Flash/EE Control MMR.
0x0E08	FEE0CON	1	RW	0x07	Flash/EE Control MMR.
0x0E0C	FEE0DAT	2	RW	0x0000	Flash/EE Data MMR.
0x0E10	FEE0ADR	2	RW		Flash/EE Address MMR.
0x0E18	FEE0SIG	3	R	0xFFFFFFFF	Flash/EE LFSR MMR.
0x0E1C	FEE0PRO	4	RW	0x00000000	Flash/EE Protection MMR.
0x0E20	FEE0HID	4	RW	0xFFFFFFFF	Flash/EE Protection MMR.
0x0E80	FEE1STA	1	R	0x20	Flash/EE Status MMR.
0x0E84	FEE1MOD	2	RW	0x00	Flash/EE Control MMR.
0x0E88	FEE1CON	1	RW	0x07	Flash/EE Control MMR.
0x0E8C	FEE1DAT	2	RW	0x0000	Flash/EE Data MMR.
0x0E90	FEE1ADR	2	RW	0x0000	Flash/EE Address MMR.
0x0E98	FEE1SIG	3	R	0xFFFFFFFF	Flash/EE LFSR MMR.
0x0E9C	FEE1PRO	4	RW	0x00000000	Flash/EE Protection MMR.
0x0EA0	FEE1HID	4	RW	0xFFFFFFFF	Flash/EE Protection MMR.

16-BIT, SIGMA-DELTA ANALOG-TO-DIGITAL CONVERTERS

The ADuC7032-8L incorporates three independent $\Sigma\text{-}\Delta$ analog-to-digital converters (ADCs), namely, the current channel ADC (I-ADC), the voltage channel ADC (V-ADC), and the temperature channel ADC (T-ADC). These precision measurement channels integrate on-chip buffering; programmable gain amplifiers; 16-bit, $\Sigma\text{-}\Delta$ modulators; and digital filtering and are intended for the precision measurement of current, voltage, and temperature variables in 12 V automotive battery systems.

CURRENT CHANNEL ADC (I-ADC)

This ADC is intended to convert battery current sensed through an external 100 $\mu\Omega$ shunt resistor. On-chip programmable gain means that the I-ADC can be configured to accommodate battery current levels from ± 1 A to ± 1500 A.

As shown in Figure 15, the I-ADC employs a $\Sigma\text{-}\Delta$ conversion technique to realize 16 bits of no missing codes performance.

The modulator converts the sampled input signal into a digital pulse train, whose duty cycle contains the digital information.

A modified Sinc3 programmable low-pass filter is then employed to decimate the modulator output data stream to give a valid 16-bit data conversion result at programmable output rates from 4 Hz to 8 kHz in normal mode and 1 Hz to 2 kHz in low power mode.

The I-ADC also incorporates counter, comparator, and accumulator logic. This allows the I-ADC result to generate an interrupt after a predefined number of conversions has elapsed or if the I-ADC result exceeds a programmable threshold value. A fast ADC overrange feature is also supported. Once enabled, a 32-bit accumulator automatically sums the 16-bit I-ADC results.

The time to a first valid (fully settled) result on the current channel is three ADC conversion cycles with chop mode turned off and two ADC conversion cycles with chop mode turned on.

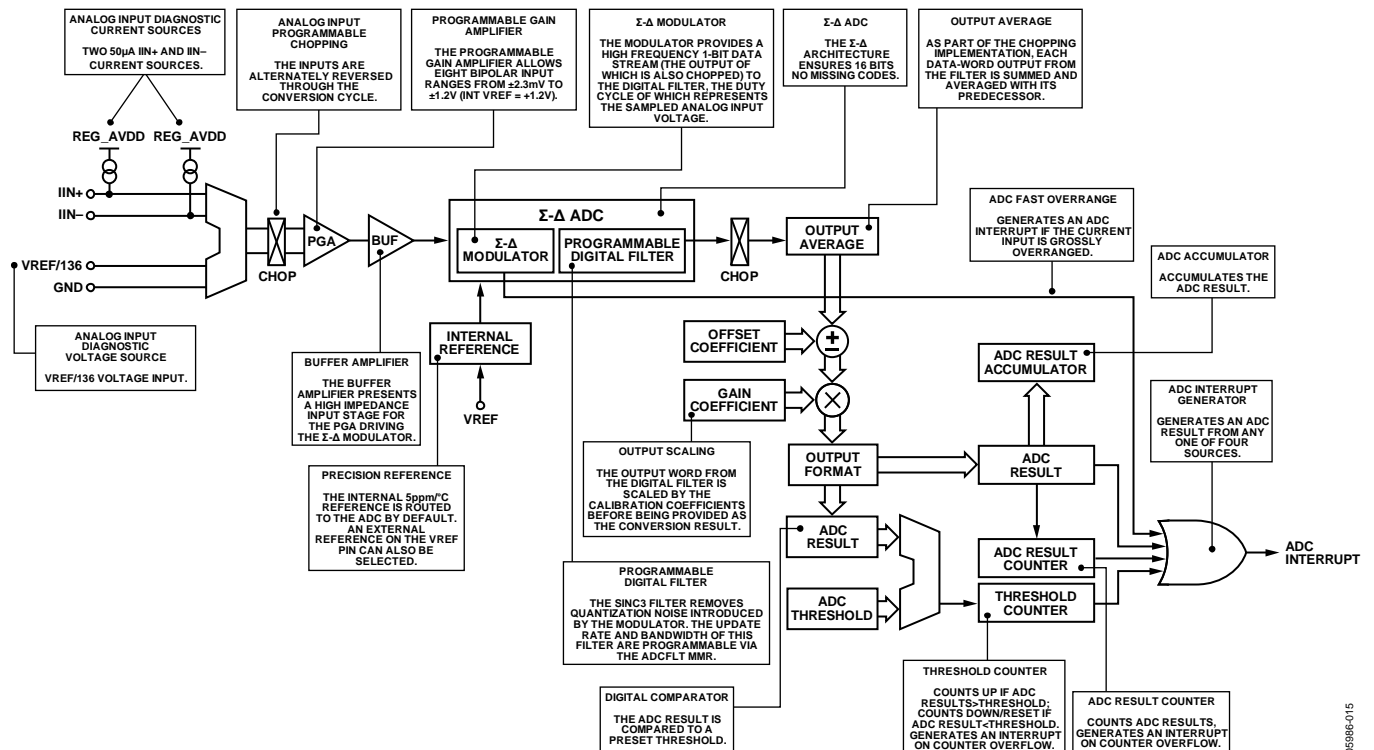

Figure 15. Current ADC, Top Level Overview

ADuC7032-8L

VOLTAGE CHANNEL ADC (V-ADC)

The V-ADC is intended to convert battery voltage. As with the current channel ADC, described in the Current Channel ADC (I-ADC) section, this ADC employs an identical Σ - Δ conversion technique, including a modified Sinc3 low-pass filter to give a valid 16-bit data conversion result at programmable output rates from 4 Hz to 8 kHz. An external RC filter network is not required because this is implemented internally in the voltage channel.

The external battery voltage (VBAT) is routed to the ADC input via an on-chip high voltage, resistive attenuator. This must be enabled/disabled via HVCFG1[7].

The time to a first valid (fully settled) result on the voltage channel is three ADC conversion cycles with chop mode turned off, and two ADC conversion cycles with chop mode turned on.

This ADC is again buffered, but, unlike the current channel, it has a fixed VBAT input range of 0 V to 28.8 V (assuming an internal 1.2 V reference). A top level overview of this ADC signal chain is shown in Figure 16.

TEMPERATURE CHANNEL ADC (T-ADC)

The T-ADC is designed to convert battery temperature. The battery temperature can be derived via the on-chip temperature sensor or an external temperature sensor input.

The time to a first valid (fully settled) result after an input channel switch on the temperature channel is three ADC conversion cycles with chop mode turned off and two ADC conversion cycles with chop mode turned on.

As with the current and voltage channel ADCs, this ADC uses an identical Σ - Δ conversion technique, including a modified Sinc3 low-pass filter to give a valid 16-bit data conversion result at programmable output rates from 4 Hz to 8 kHz.

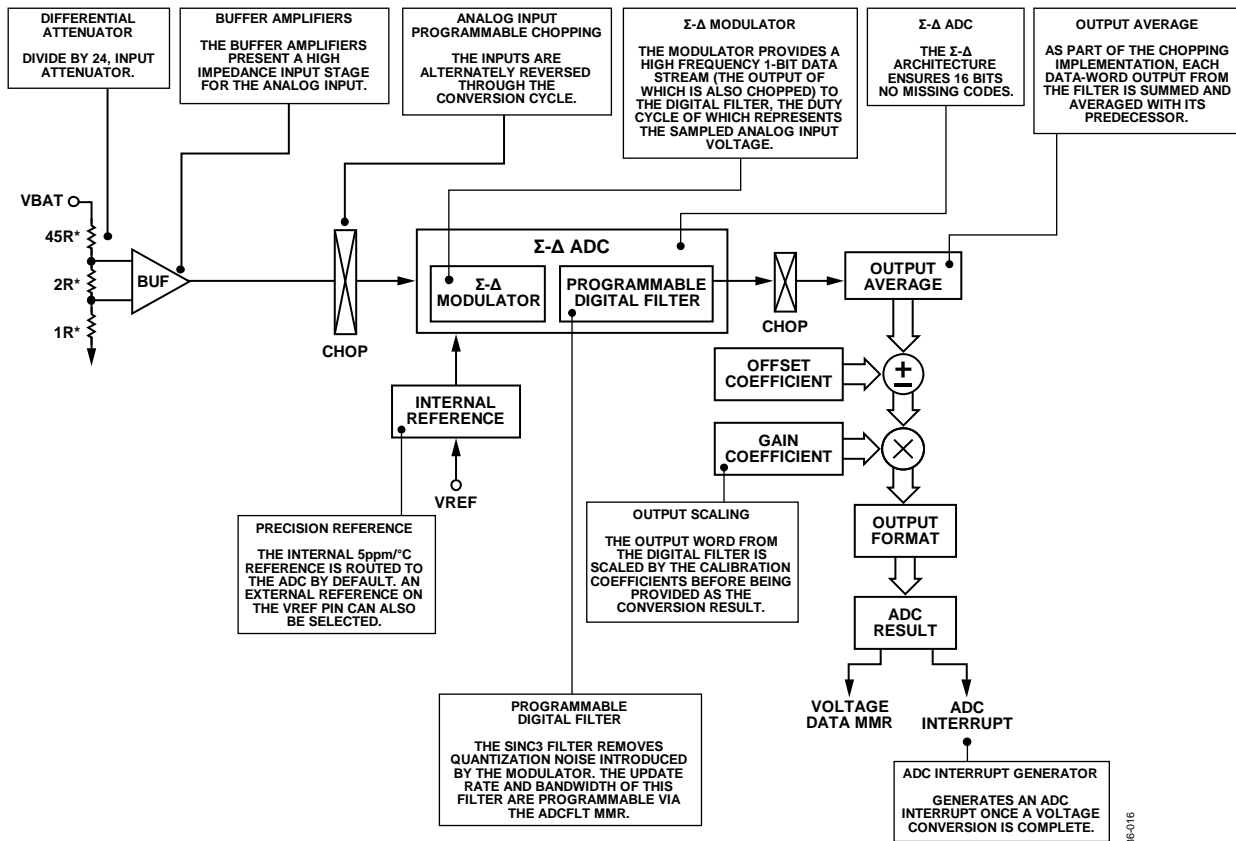

Figure 16. Voltage ADC, Top Level Overview

ADC GROUND SWITCH

The ADuC7032-8L features an integrated ground switch pin, GND_SW, located on Pin 15. This switch allows the user to dynamically disconnect ground from external devices. It allows either a direct connection to ground or a connection to ground via a 20 kΩ resistor. This additional resistor can be used to reduce the number of external components required for an NTC circuit.

The ground switch feature can be used for reducing power consumption on application-specific boards.

An example application is shown in Figure 17. This diagram shows an external NTC used in two modes. One mode uses the internal 20 kΩ resistor, and the second mode shows a direct connection to ground via the GND_SW. ADCCFG[7] controls the connection of the ground switch to ground, and ADCMDE[6] controls the GND_SW resistance.

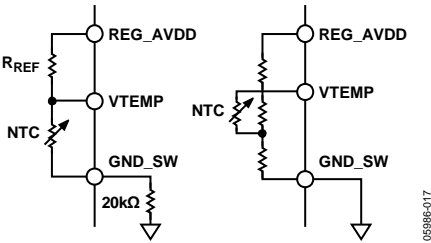

Figure 17. Example of External Temperature Sensor Circuits

The possible bit combinations are shown in Table 31.

Table 31. GND_SW Configuration

ADCCFG[7]	ADCMDE[6]	GND_SW
0	0	Floating.
0	1	Floating.
1	0	Direct connection to ground.
1	1	Connected to ground via a 20 kΩ resistor.

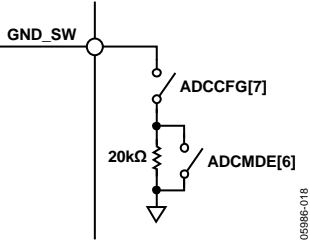

Figure 18. Internal Ground Switch Configuration

ADuC7032-8L

ADC NOISE PERFORMANCE TABLES

Table 32, Table 33, and Table 34 show the output rms noise in microvolts (μV) for some typical output update rates on the I-, V-, and T-ADCs. The numbers are typical and are generated at a differential input voltage of 0 V. The output rms noise is specified as the standard deviation (or one sigma) of the distribution of ADC output codes collected when the ADC input voltage is at a dc voltage. It is expressed as microvolts rms ($\mu\text{V rms}$).

Table 32. Current Channel ADC, Normal Power Mode, Typical Output RMS Noise (μV)

ADCFLT	Data Update Rate	ADC Input Range									
		$\pm 2.3\text{ mV}$ (512)	$\pm 4.6\text{ mV}$ (256)	$\pm 9.375\text{ mV}$ (128)	$\pm 18.75\text{ mV}$ (64)	$\pm 37.5\text{ mV}$ (32)	$\pm 75\text{ mV}$ (16)	$\pm 150\text{ mV}$ (8)	$\pm 300\text{ mV}$ (4 ¹)	$\pm 600\text{ mV}$ (2 ¹)	$\pm 1.2\text{ V}$ (1 ¹)
0xBF1D	4 Hz	0.040 μV	0.040 μV	0.043 μV	0.087 μV	0.087 μV	0.175 μV	0.35 μV	0.7 μV	2.8 μV	2.8 μV
0x961F	10 Hz	0.060 μV	0.060 μV	0.060 μV	0.087 μV	0.087 μV	0.175 μV	0.35 μV	0.7 μV	2.8 μV	2.8 μV
0x007F	50 Hz	0.142 μV	0.142 μV	0.144 μV	0.145 μV	0.170 μV	0.305 μV	0.380 μV	0.7 μV	2.8 μV	2.8 μV
0x0007	1 kHz	0.620 μV	0.620 μV	0.625 μV	0.625 μV	0.770 μV	1.310 μV	1.650 μV	2.520 μV	7.600 μV	7.600 μV
0x0000	8 kHz	2.000 μV	2.000 μV	2.000 μV	2.000 μV	2.650 μV	4.960 μV	8.020 μV	15.0 μV	55.0 μV	55.0 μV

¹ The maximum absolute input voltage allowed is -200 mV to $+300\text{ mV}$ relative to ground.

Table 33. Voltage Channel ADC, Typical Output RMS Noise (Referred to ADC Voltage Attenuator Input) (μV)

ADCFLT	Data Update Rate	0 V to 28.8 V—ADC Input Range
0xBF1D	4 Hz	65 μV
0x961F	10 Hz	65 μV
0x0007	1 kHz	180 μV
0x0000	8 kHz	1600 μV

Table 34. Temperature Channel ADC, Typical Output RMS Noise (μV)

ADCFLT	Data Update Rate	0 V to 1.2 V—ADC Input Range
0xBF1D	4 Hz	2.8 μV
0x961F	10 Hz	2.8 μV
0x0007	1 kHz	7.5 μV
0x0000	8 kHz	55 μV

ADC MMR INTERFACE

The ADC is controlled and configured via a number of MMRs that are described in detail on the following pages.

All bits defined in the top eight MSBs (Bit 8 to Bit 15) of the ADCSTA MMR (see Table 35) are used as flags only and do not generate interrupts. All bits defined in the lower eight LSBs (Bit 0 to Bit 7) of this MMR are logic OR'ed to produce a single ADC interrupt to the MCU core.

In response to an ADC interrupt, user code should interrogate the ADCSTA MMR to determine the source of the interrupt.

Each ADC interrupt source can be individually masked via the ADCMSKI MMR, as described in the ADC Interrupt Source Enable Register section.

ADC Status Register

Name: ADCSTA

Address: 0xFFFFF0500

Default Value: 0x0000

Access: Read only

Function: This register holds general status information related to the mode of operation or current status of the ADuC7032-8L ADCs.

All ADC result-ready bits are cleared by a read of the ADC0DAT MMR. If the current channel ADC is not enabled, all ADC result-ready bits are cleared by a read of the ADC1DAT or ADC2DAT MMRs.

To ensure that I-ADC, V-ADC, and T-ADC conversion data is synchronous, user code should first read the ADC2DAT/ADC1DAT MMRs and then the ADC0DAT MMR. New ADC conversion results are not written to the ADCxDAT MMRs unless the respective ADC result-ready bits are first cleared. The only exception to this rule is data conversion result updates when the ARM core is powered down. In this mode, ADCxDAT registers always contain the most recent ADC conversion results, even though the ready bits have not been cleared.

Table 35. ADCSTA MMR Bit Designations

Bit	Description
15	ADC Calibration Status. Set automatically in hardware to indicate that an ADC calibration cycle has been completed. Cleared after ADCMDE is written to.
14	ADC Temperature Conversion Error. Set automatically in hardware to indicate that a temperature conversion overrange or underrange has occurred. The conversion result is clamped to negative full scale (underrange error) or positive full scale (overrange error) in this case. Cleared when a valid (in-range) temperature conversion result is written to the ADC2DAT register.
13	ADC Voltage Conversion Error. Set automatically in hardware to indicate that a voltage conversion overrange or underrange has occurred. The conversion result is clamped to negative full scale (underrange error) or positive full scale (overrange error) in this case. Cleared when a valid (in-range) voltage conversion result is written to the ADC1DAT register.
12	ADC Current Conversion Error. Set automatically in hardware to indicate that a current conversion overrange or underrange has occurred. The conversion result is clamped to negative full scale (underrange error) or positive full scale (overrange error) in this case. Cleared when a valid (in-range) current conversion result is written to the ADC0DAT register.
11	Not Used. Reserved for future functionality and should not be monitored by user code.
10	Not Used. Reserved for future functionality and should not be monitored by user code.
9	ADC FIFO Error Flag. Set to 1 automatically to indicate that the FIFO has overflowed. This bit does not cause an interrupt but is latched high and can be cleared only by disabling the FIFO or reconfiguring the ADC. Reads 0 if the FIFO is disabled or if the FIFO has not overflowed.
8	ADC FIFO Empty Flag. Set to 1 automatically to indicate the ADC FIFO is empty. It is a flag bit only and cannot generate an interrupt. Reads 0 if the ADC FIFO is disabled.
7	ADC FIFO Full Flag. Set to 1 automatically to indicate the ADC FIFO is full. Any subsequent I-ADC and V-ADC conversion results cause an overflow and corrupt the ADC FIFO. Cleared by disabling the FIFO or reconfiguring the ADC.
6	Accumulator Comparator Threshold Exceeded. Indicates that the absolute value of the current channel accumulator has exceeded the programmed threshold. Cleared by disabling the accumulator comparator function in ADCCFG[6:5] or by reconfiguring the ADC.
5	Not Used. Reserved for future functionality and should not be monitored by user code.

ADuC7032-8L

Bit	Description
4	<p>Current Channel ADC Comparator Threshold.</p> <p>Valid only if the current channel ADC comparator is enabled via the ADCCFG MMR.</p> <p>Set by hardware if the absolute value of the I-ADC conversion result exceeds the value written in the ADC0TH MMR. If the ADC threshold counter is used (ADCOTCL), this bit is set only when the specified number of I-ADC conversions equals the value in the ADC0THV MMR.</p>
3	<p>Current Channel ADC Overrange Bit.</p> <p>If the overrange detect function is enabled via the ADCCFG MMR, this bit is set by hardware if the I-ADC input is grossly (>30% approximately) overranged. This bit is updated every 125 μs.</p> <p>When set, this bit can only be cleared by software when ADCCFG[2] is cleared to disable the function or the ADC gain is changed via the ADC0CON MMR.</p>
2	<p>Temperature Conversion Result-Ready Bit.</p> <p>If the temperature channel ADC is enabled, this bit is set by hardware as soon as a valid temperature conversion result is written in the temperature data register (ADC2DAT MMR).</p> <p>Cleared by reading either ADC2DAT or ADC0DAT.</p>
1	<p>Voltage Conversion Result-Ready Bit.</p> <p>If the voltage channel ADC is enabled, this bit is set by hardware as soon as a valid voltage conversion result is written in the voltage data register (ADC1DAT MMR).</p> <p>Cleared by reading either ADC1DAT or ADC0DAT.</p>
0	<p>Current Conversion Result-Ready Bit.</p> <p>If the current channel ADC is enabled, this bit is set by hardware as soon as a valid current conversion result is written in the current data register (ADC0DAT MMR).</p> <p>Cleared by reading ADC0DAT.</p>

ADC Interrupt Source Enable Register

Name: ADCMSKI

Address: 0xFFFF0504

Default Value: 0x00

Access: Read/write

Function: This register allows the ADC interrupt sources to be enabled individually. The bit positions in this register are the same as the lower eight bits in the ADCSTA MMR. If a bit is set by user code to 1, the respective interrupt is enabled. By default, all bits are set to 0, meaning that all ADC interrupt sources are disabled.

ADC Mode Register**Name:** ADCMDE**Address:** 0xFFFF0508**Default Value:** 0x00**Access:** Read/write**Function:** The ADC Mode MMR is an 8-bit register that configures the mode of operation of the ADC subsystem.**Table 36. ADCMDE MMR Bit Designations**

Bit	Description
7	Not Used. This bit is reserved for future functionality and must be written as 0 by user code.
6	20 k Ω Resistor Select. Set to 1 to select the 20 k Ω resistor, as shown in Figure 18. Set to 0 to select the direct path to ground, as shown in Figure 18 (default).
5	Low Power Mode Reference Select. Set to 1 to enable the precision voltage reference in ADC low power mode. This increases current consumption. Set to 0 to enable the low power voltage reference in ADC low power mode (default).
4 to 3	ADC Power Mode Configuration. 00 = ADC normal mode. If enabled, the ADC operates with normal current consumption yielding optimum electrical performance. 01 = ADC low power mode. If enabled, the I-ADC operates with reduced current consumption. This limitation in current consumption is achieved (at the expense of ADC noise performance) by fixing the gain to 128 and using the on-chip low power (131 kHz) oscillator to drive the ADC circuits directly. 10 = ADC low power plus mode. If enabled, the I-ADC again operates with reduced current consumption. In this mode, the gain is fixed to 512, and the current consumed is 200 μ A (approximately) more than ADC low power mode, shown previously. The additional current consumed also ensures ADC noise performance is better than that achieved in ADC low power mode. 11 = not defined.
2 to 0	ADC Operation Mode Configuration. 000 = ADC power-down mode. All ADC circuits (including internal reference) are powered-down. 001 = ADC continuous conversion mode. In this mode, any enabled ADC continuously converts. 010 = ADC single conversion mode. In this mode, any enabled ADC performs a single conversion. The ADC enters idle mode once the single-shot conversion is complete. A single conversion takes two to three ADC clock cycles, depending on the chop mode. 011 = ADC idle mode. In this mode, the ADC is fully powered on but is held in r. 100 = ADC self-offset calibration. In this mode, an offset calibration is performed on any enabled ADC using an internally generated 0 V. The calibration is carried out at the user-programmed ADC settings; therefore, as with a normal single ADC conversion, it takes two to three ADC conversion cycles before a fully settled calibration result is ready. The calibration result is automatically written to the ADCxOF MMR of the respective ADC. The ADC returns to idle mode and the calibration- and conversion-ready status bits are set at the end of an offset calibration cycle. 101 = ADC self-gain calibration. In this mode, a gain calibration against an internal reference voltage is performed on all enabled ADCs. A gain calibration is a two-stage process that takes twice the time of an offset calibration. The calibration result is automatically written to the ADCxGN MMR of the respective ADC. The ADC returns to idle mode, and the calibration- and conversion-ready status bits are set at the end of a gain-calibration cycle. An ADC self-gain calibration should only be carried out on the current channel ADC, while preprogrammed, factory calibration coefficients (downloaded automatically from internal Flash) should be used for voltage temperature measurements. If an external NTC is used, an ADC self-calibration should be done on the temperature channel. 110 = ADC system zero-scale calibration. In this mode, a zero-scale calibration is performed on enabled ADC channels against an external zero-scale voltage driven at the ADC input pins. The calibration is carried out at the user programmed ADC settings; therefore, as with a normal single ADC conversion, it takes three ADC conversion cycles before a fully settled calibration result is ready. 111 = ADC system full-scale calibration.

ADuC7032-8L

Current Channel ADC Control Register

Name: ADC0CON

Address: 0xFFFF050C

Default Value: 0x00002

Access: Read/write

Function: The current channel ADC control MMR is a 16-bit register that is used to configure the I-ADC. Note that if the current ADC is reconfigured via ADC0CON, the voltage and temperature ADCs are also reset.

Table 37. ADC0CON MMR Bit Designations

Bit	Description
15	Current Channel ADC Enable. Set to 1 by user code to enable the I-ADC. Cleared to 0 to power down the I-ADC and reset the respective ADC ready bit in the ADCSTA MMR to 0.
14 to 13	Current Source Enable. 00 = current sources off. 01 = enable 50 μ A current source on IIN+. 10 = enable 50 μ A current source on IIN-. 11 = enable 50 μ A current source on both IIN- and IIN+.
12 to 10	Not Used. Reserved for future functionality and should be written as 0.
9	Current Channel ADC Output Coding. Set to 1 by user code to configure I-ADC output coding as unipolar. Cleared to 0 by user code to configure I-ADC output coding as twos complement.
8	Not Used. Reserved for future functionality and should be written as 0.
7 to 6	Current Channel ADC Input Select. 00 = IIN+, IIN-. 01 = IIN-, IIN-. Diagnostic, internal short configuration. 10 = ADC reference/136, 0 V. Diagnostic, test voltage for gain settings \leq 128. 11 = not defined.
5 to 4	Current Channel ADC Reference Select. 00 = internal, 1.2 V precision reference selected. In ADC low power mode, the voltage reference selection is controlled by ADCMDE[5]. 01 = external reference inputs (VREF, GND_SW) selected. 10 = external reference inputs divided by 2 ((VREF, GND_SW)/2) selected allows an external reference up to REG_AVDD. 11 = (REG_AVDD, AGND)/2 selected.
3 to 0	Current Channel ADC Gain Select. (Note that nominal I-ADC full-scale input voltage = VREF/GAIN.) 0000 = I-ADC gain = 1. 0001 = I-ADC gain = 2. 0010 = I-ADC gain = 4. 0011 = I-ADC gain = 8. 0100 = I-ADC gain = 16. 0101 = I-ADC gain = 32. 0110 = I-ADC gain = 64. 0111 = I-ADC gain = 128. 1000 = I-ADC gain = 256. 1001 = I-ADC gain = 512. 1xxx = I-ADC gain is undefined.

Voltage Channel ADC Control Register**Name:** ADC1CON**Address:** 0xFFFFF0510**Default Value:** 0x0000**Access:** Read/write

Function: The voltage channel ADC control MMR is a 16-bit register that is used to configure the V-ADC. Note that when enabling/disabling the voltage ADC, the voltage attenuator must also be enabled/disabled via HVCFG1[7].

Table 38. ADC1CON MMR Bit Designations

Bit	Description
15	Voltage Channel ADC Enable . Set to 1 by user code to enable the V-ADC. When enabling/disabling the voltage ADC, the voltage attenuator must also be enabled/disabled via HVCFG1[7]. Cleared to 0 to power down the V-ADC.
14 to 10	Not Used. Reserved for future functionality and should not be modified by user code.
9	Voltage Channel ADC Output Coding. Set to 1 by user code to configure V-ADC output coding as unipolar. Cleared to 0 by user code to configure V-ADC output coding as twos complement.
8	Not Used. This bit is reserved for future functionality and should be written as 0 by user code.
7 to 6	Voltage Channel ADC Input Select. 00 = VBAT/24, AGND; VBAT attenuator selected. 01 = not defined. 10 = not defined. 11 = internal short; shorted input.
5 to 4	Voltage Channel ADC Reference Select. 00 = internal, 1.2 V precision reference selected. 01 = external reference inputs (VREF, GND_SW) selected. 10 = external reference inputs divided by 2 ((VREF, GND_SW)/2) selected. This allows an external reference up to REG_AVDD. 11 = (REG_AVDD, AGND) divided by 2 selected.
3 to 0	Not Used. Reserved for future functionality and should be written as 0 by user code.

Temperature Channel ADC Control Register**Name:** ADC2CON**Address:** 0xFFFFF0514**Default Value:** 0x0000**Access:** Read/write

Function: The temperature channel ADC control MMR is a 16-bit register that is used to configure the T-ADC.

Table 39. ADC2CON MMR Bit Designations

Bit	Description
15	Temperature Channel ADC Enable. Set to 1 by user code to enable the T-ADC. Cleared to 0 to power down the T-ADC.
14 to 13	VTEMP Current Source Enable. 00 = current sources off. 01 = enable 50 μ A current source on VTEMP. 10 = enable 50 μ A current source on GND_SW. 11 = enable 50 μ A current source on both VTEMP and GND_SW. Note that these current sources have a tolerance of $\pm 30\%$.
12 to 10	Not Used. Reserved for future functionality and should not be modified by user code.
9	Temperature Channel ADC Output Coding. Set to 1 by user code to configure T-ADC output coding as unipolar. Cleared to 0 by user code to configure T-ADC output coding as twos complement.
8	Not Used. Reserved for future functionality and should be written as 0 by user code.

ADuC7032-8L

Bit	Description
7 to 6	Temperature Channel ADC Input Select. 00 = internal temperature sensor. The temperature channel is calibrated to read 0x0000 at 0 K. The temperature gradient is then 16 codes per degree Celsius in twos complement or 32 codes in unipolar mode. This is applicable only to the internal temperature sensor. 01 = external (VTEMP, GND_SW). 10 = shorted input (GND_SW, GND_SW). 11 = I-ADC reference selected in ADC0CON/136.
5 to 4	Temperature Channel ADC Reference Select. 00 = internal, 1.2 V precision reference selected. 01 = external reference inputs (VREF, GND_SW) selected. 10 = external reference inputs divided by 2 ((VREF, GND_SW)/2) selected; this allows an external reference up to REG_AVDD. 11 = (REG_AVDD, GND_SW) divided by 2 selected; used for external temperature sensor measurements.
3 to 0	Not Used. Reserved for future functionality and should be written as 0 by user code.

ADC Filter Register**Name:** ADCFLT**Address:** 0xFFFF0518**Default Value:** 0x0007**Access:** Read/write**Function:** The ADC filter MMR is a 16-bit register that controls the speed and resolution of the on-chip ADCs.**Note:** If ADCFLT is modified, the current, voltage, and temperature ADCs are reset. An additional time of 60 μ s per enabled ADC is required before the first ADC result is available.**Table 40. ADCFLT MMR Bit Designations**

Bit	Description
15	Chop Enable. Set by user to enable system chopping of all active ADCs. When this bit is set, the ADC has very low offset errors and drift, but the ADC output rate is reduced by a factor of 3 if AF = 0 (see Sinc3 decimation factor bits, Bit 6 to Bit 0). If AF \neq 0, then the ADC output update rate is the same with chop on or off. When chop is enabled, the settling time is two output periods.
14	Running Average. Set by user to enable a running average-by-2 function, reducing ADC noise. This function is automatically enabled when chopping is active. It is an optional feature when chopping is inactive and, if enabled (when chopping is inactive), it does not reduce ADC output rate but increases the settling time by one conversion period. Cleared by user to disable the running average function.
13 to 8	Averaging Factor (AF). The value written to these bits is used to implement a programmable first-order Sinc3 post filter. The averaging factor can further reduce ADC noise at the expense of output rate, as described in the Sinc3 decimation factor bits (Bit 6 to Bit 0).
7	Sinc3 Modify. Set by user to modify the standard Sinc3 frequency response to increase the filter stop-band rejection by 5 dB approximate. This is achieved by inserting a second notch (NOTCH2) at $f_{\text{NOTCH2}} = 1.333 \times f_{\text{NOTCH}}$ where f_{NOTCH} is the location of the first notch in the response.
6 to 0	Sinc3 Decimation Factor (SF). The value (SF) written in these bits controls the oversampling (decimation factor) of the Sinc3 filter. The output rate from the Sinc3 filter is given by $f_{\text{ADC}} = (512,000/([SF+1] \times 64))$ Hz when the chop bit (Bit 15) = 0 and AF = 0 (AF = averaging factor). ^{1,2}

¹ This is valid for all SF values \leq 125. For SF = 126, f_{ADC} is forced to 60 Hz. For SF = 127, f_{ADC} is forced to 50 Hz.² For information on calculating the f_{ADC} for SF (other than 126 and 127) and AF values, see Table 41.

Note that due to limitations on the digital filter internal datapath, there are some limitations on the combinations of SF (Sinc3 decimation factor) and AF (averaging factor) that can be used to generate a required ADC output rate. This restriction limits the minimum ADC update to 4 Hz in normal power mode or to 1 Hz in low power mode. If all three ADCs are enabled, then the minimum value of SF written by user code must be 1.

In low power mode and low power plus mode, the ADC is driven directly by the low power oscillator, or 131 kHz, and not 512 kHz. All f_{ADC} calculations should be divided by 4 (approximate).

For optimal ADC performance, SF should be increased before AF is used.

ADuC7032-8L

Table 41. ADC Conversion Rates and Settling Times

Chop Enabled	Running Average	Averaging Factor	f_{ADC}	Time Settling ¹
No	No	No	$\frac{512,000}{[SF + 1] \times 64}$	$\frac{3}{f_{ADC}}$
No	No	Yes	$\frac{512,000}{[SF + 1] \times 64 \times [3 + AF]}$	$\frac{4}{f_{ADC}}$
No	Yes	No	$\frac{512,000}{[SF + 1] \times 64}$	$\frac{1}{f_{ADC}}$
No	Yes	Yes	$\frac{512,000}{[SF + 1] \times 64 \times [3 + AF]}$	$\frac{2}{f_{ADC}}$
Yes	N/A	N/A	$\frac{512,000}{[SF + 1] \times 64 \times [3 + AF] + 3}$	$\frac{2}{f_{ADC}}$

¹ An additional time of 60 μ s per enabled ADC is required before the first ADC result is available.

Table 42. Allowable Combinations of SF and AF

SF/AF Range	0	1 to 7	8 to 63
≤ 31	Yes	Yes	Yes
32 to 63	Yes	Yes	No
64 to 127	Yes	No	No

ADC Configuration Register**Name:** ADCCFG**Address:** 0xFFFF051C**Default Value:** 0x00**Access:** Read/write**Function:** The 8-bit ADC configuration MMR controls extended functionality related to the on-chip ADCs.**Table 43. ADCCFG MMR Bit Designations**

Bit	Description
7	<p>Analog Ground Switch Enable.</p> <p>Set to 1 by user software to connect the external GND_SW pin (Pin 15) to an internal analog ground reference point. This bit can be used to connect and disconnect external circuits and components to ground under program control and thereby minimize dc current consumption when the external circuit or component is not being used. This bit is used in conjunction with ADCMDE[6] to select a 20 kΩ resistor to ground.</p>
6 to 5	<p>Current Channel (32-Bit) Accumulator Enable.</p> <p>00 = accumulator disabled and reset to 0. The accumulator must be disabled for a full ADC conversion, (ADCSTA[0] set twice) before the accumulator can be re-enabled to ensure the accumulator is reset.</p> <p>01 = accumulator active.</p> <p>Positive current values are added to the accumulator total. The accumulator can overflow if allowed to run for >65,535 conversions.</p> <p>Negative current values are subtracted from the accumulator total. The accumulator is clamped to a minimum value of 0.</p> <p>10 = accumulator active.</p> <p>Positive current values are added to the accumulator total. The accumulator can overflow if allowed to run for >65,535 conversions.</p> <p>The absolute values of negative current are subtracted from the accumulator total. In this mode, the accumulator continues to accumulate negatively, below 0.</p> <p>11 = accumulator and accumulator comparator enabled. This mode is the same as Mode 10 but with the accumulator comparator enabled.</p>
4 to 3	<p>Current Channel ADC Comparator Enable.</p> <p>00 = comparator disabled.</p> <p>01 = comparator active, interrupt asserted if absolute value of I-ADC conversion result $\geq \text{ADC0TH}$.</p> <p>10 = comparator-count mode active, interrupt asserted if the absolute value of an I-ADC conversion result $\geq \text{ADC0TH}$ for number of ADC0TCL conversions; conversion value $< \text{ADC0TH}$ resets the threshold counter value (ADC0THV) to 0.</p> <p>11 = comparator-count mode active, interrupt asserted if absolute value of an I-ADC conversion result $\geq \text{ADC0TH}$ for number of ADC0TCL conversions; conversion value $< \text{ADC0TH}$ decrements the threshold counter value (ADC0THV) towards 0.</p>
2	<p>Current Channel ADC Overrange Enable.</p> <p>Set by user to enable a coarse comparator on the current channel ADC. If the current reading is grossly (>30% approximate) overranged for the active gain setting, then the overrange bit in the ADCSTA MMR is set. For the flag to be set, the current must be outside this range for >125 μs. This feature should not be used in ADC low power mode.</p>
1	<p>ADC FIFO Enable.</p> <p>Set to 1 by user code to enable ADC FIFO on current and voltage ADC channels. The FIFO function allows up to 32 current and voltage ADC results to be stored in an on-chip FIFO. The current status of the FIFO is reflected by three bits in the ADCSTA register. If more than 32 results are stored in the FIFO, the contents of the FIFO may be corrupted.</p>
0	<p>Current Channel ADC, Result Counter Enable.</p> <p>Set by user to enable the result count mode. In this mode, an I-ADC interrupt is generated only when ADC0RCV = ADC0RCL. This allows the I-ADC to continuously monitor current but interrupt the MCU core only after a defined number of conversions. Note that unless the ADC FIFO is enabled (ADCCNG[1] = 1), only the last conversion value is available (intermediate I-ADC conversion results are not stored) when the ADC counter interrupt occurs. The voltage and temperature ADCs also continue to convert if enabled, but again, only the last conversion result is available (intermediate V-ADC and T-ADC conversion results are not stored) when the ADC counter interrupt occurs.</p>

Current Channel ADC Data Register

Name: ADC0DAT

Address: 0xFFFF0520

Default Value: 0x0000

Access: Read only

Function: This current channel ADC data MMR holds the 16-bit conversion result from the I-ADC. The ADC does not update this MMR if the ADC conversion result-ready bit (ADCSTA[0]) is set. A read of this MMR by the MCU clears all asserted ready flags (ADCSTA[2:0]).

Voltage Channel Data Register

Name: ADC1DAT

Address: 0xFFFF0524

Default Value: 0x0000

Access: Read only

Function: This V-ADC data MMR holds the 16-bit conversion result from the V-ADC. The ADC does not update this MMR if the voltage conversion result-ready bit (ADCSTA[1]) is set. If I-ADC is not active, a read of this MMR by the MCU clears all asserted ready flags (ADCSTA[2:1]).

Temperature Channel ADC Data Register

Name: ADC2DAT

Address: 0xFFFF0528

Default Value: 0x0000

Access: Read only

Function: This T-ADC data MMR holds the 16-bit conversion result from the T-ADC. The ADC does not update this MMR if the temperature conversion result-ready bit (ADCSTA[2]) is set. A read of this MMR clears ADCSTA[2].

ADC FIFO Register

Name: ADCFIFO

Address: 0xFFFF052C

Default Value: 0x0000

Access: Read only

Function: This 32-bit, read-only register returns the value of the I-ADC and V-ADC conversion result held in the FIFO location currently pointed to by the FIFO read pointer. The low 16 bits [15:0] of this 32-bit word are the I-ADC result, and the high 16 bits [31:16] are the V-ADC result. The FIFO function is enabled via the ADCCFG[1] bit, and three flags available in the ADCSTA register allow user code to monitor and read the FIFO contents.

Current Channel ADC Offset Calibration Register

Name: ADC0OF

Address: 0xFFFF0530

Default Value: Part-specific, factory programmed

Access: Read/write

Function: This ADC offset MMR holds a 16-bit offset calibration coefficient for the I-ADC. The register is configured at power-on with a factory default value. However, this register is automatically overwritten if an offset calibration of the I-ADC is initiated by the user via bits in the ADCMDE MMR. User code can write to this calibration register only if the ADC is in idle mode. An ADC must be enabled and in idle mode before being written to any offset or gain register. The ADC must be in idle mode for at least 23 μ s.

Voltage Channel ADC Offset Calibration Register

Name: ADC1OF

Address: 0xFFFF0534

Default Value: Part-specific, factory programmed

Access: Read/write

Function: This V-ADC offset MMR holds a 16-bit offset calibration coefficient for the voltage channel. The register is configured at power-on with a factory default value. However, this register is automatically overwritten if an offset calibration of the voltage channel is initiated by the user via bits in the ADCMDE MMR. User code can write to this calibration register only if the ADC is in idle mode. An ADC must be enabled and in idle mode before being written to any offset or gain register. The ADC must be in idle mode for at least 23 μ s.

Temperature Channel ADC Offset Calibration Register

Name: ADC2OF

Address: 0xFFFF0538

Default Value: Part-specific, factory programmed

Access: Read/write

Function: This T-ADC offset MMR holds a 16-bit offset calibration coefficient for the temperature channel. The register is configured at power-on with a factory default value. However, this register is automatically overwritten if an offset calibration of the temperature channel is initiated by the user via bits in the ADCMDE MMR. User code can write to this calibration register only if the ADC is in idle mode. An ADC must be enabled and in idle mode before writing to any offset or gain register. The ADC must be in idle mode for at least 23 μ s.

Current Channel ADC Gain Calibration Register**Name:** ADC0GN**Address:** 0xFFFF053C**Default Value:** Part-specific, factory programmed**Access:** Read/write

Function: This I-ADC gain MMR holds a 16-bit gain calibration coefficient for scaling the I-ADC conversion result. The register is configured at power-on with a factory default value. However, this register is automatically overwritten if a gain calibration of the I-ADC is initiated by the user via bits in the ADCMDE MMR. User code can write to this calibration register only if the ADC is in idle mode. An ADC must be enabled and in idle mode before being written to any offset or gain register. The ADC must be in idle mode for at least 23 μ s.

Voltage Channel ADC Gain Calibration Register**Name:** ADC1GN**Address:** 0xFFFF0540**Default Value:** Part-specific, factory programmed**Access:** Read/write

Function: This gain MMR holds a 16-bit gain calibration coefficient for scaling a voltage channel conversion result. The register is configured at power-on with a factory default value. However, this register is automatically overwritten if a gain calibration of the voltage channel is initiated by the user via bits in the ADCMDE MMR. User code can write to this calibration register only if the ADC is in idle mode. An ADC must be enabled and in idle mode before being written to any offset or gain register. The ADC must be in idle mode for at least 23 μ s.

Temperature Channel ADC Gain Calibration Register**Name:** ADC2GN**Address:** 0xFFFF0544**Default Value:** Part-specific, factory programmed**Access:** Read/write

Function: This T-ADC gain MMR holds a 16-bit gain calibration coefficient for scaling a temperature channel conversion result. The register is configured at power-on with a factory default value. However, this register is automatically overwritten if a gain calibration of the temperature channel is initiated by the user via bits in the ADCMDE MMR. User code can write to this calibration register only if the ADC is in idle mode. An ADC must be enabled and in idle mode before being written to any offset or gain register. The ADC must be in idle mode for at least 23 μ s.

Current Channel ADC Result Counter Limit Register**Name:** ADC0RCL**Address:** 0xFFFF0548**Default Value:** 0x0001**Access:** Read/write

Function: This 16-bit MMR sets the number of conversions required before an ADC interrupt is generated. By default, this register is set to 0x0001. The ADC counter function must be enabled via the ADC result counter enable bit in the ADCCFG MMR.

Current Channel ADC Result Counter Value Register**Name:** ADC0RCV**Address:** 0xFFFF054C**Default Value:** 0x0000**Access:** Read only

Function: This 16-bit, read-only MMR holds the current number of I-ADC conversion results. It is used in conjunction with ADC0RCL to mask I-ADC interrupts, generating a lower interrupt rate. Once ADC0RCV = ADC0RCL, the value in ADC0RCV resets to 0 and recommences counting. It can also be used in conjunction with the accumulator (ADC0ACC) to allow an average current calculation to be undertaken. The result counter is enabled via ADCCFG[0]. This MMR is also reset to 0 when the I-ADC is reconfigured, that is, when the ADC0CON or ADCMDE are written.

Current Channel ADC Threshold Register**Name:** ADC0TH**Address:** 0xFFFF0550**Default Value:** 0x0000**Access:** Read/write

Function: This 16-bit MMR sets the threshold against which the absolute value of the I-ADC conversion result is compared. In unipolar mode, ADC0TH[15:0] are compared; and in twos complement mode, ADC0TH[14:0] are compared.

Current Channel ADC Threshold Count Limit Register**Name:** ADC0TCL**Address:** 0xFFFF0554**Default Value:** 0x01**Access:** Read/write

Function: This 8-bit MMR determines how many cumulative (values below the threshold decrement or reset the count to 0) I-ADC conversion result readings above ADC0TH must occur before the I-ADC comparator threshold bit is set in the ADCSTA MMR, generating an ADC interrupt. The I-ADC comparator threshold bit is asserted as soon as the ADC0THV = ADC0TCL.

Current Channel ADC Threshold Count Register

Name: ADC0THV

Address: 0xFFFF0558

Default Value: 0x00

Access: Read only

Function: This 8-bit MMR is incremented every time the absolute value of an I-ADC conversion result $|I| \geq \text{ADC0TH}$. This register is decremented or reset to 0 every time the absolute value of an I-ADC conversion result $|I| < \text{ADC0TH}$. The configuration of this function is enabled via the current channel ADC comparator bits in the ADCCFG MMR.

Current Channel ADC Accumulator Register

Name: ADC0ACC

Address: 0xFFFF055C

Default Value: 0x00000000

Access: Read only

Function: This 32-bit MMR holds the current channel accumulator value. The I-ADC ready bit in the ADCSTA MMR should be used to determine when it is safe to read this MMR. The MMR value is reset to 0 by disabling the accumulator in the ADCCFG MMR or reconfiguring the current channel ADC.

Current Channel ADC Accumulator Threshold Register

Name: ADC0ATH

Address: 0xFFFF0560

Default Value: 0x00000000

Access: Read/write

Function: This 32-bit MMR sets the threshold against which the accumulated value of the I-ADC results is compared. In unipolar mode, ADC0ATH [15:0] are compared and in twos complement mode, ADC0ATH[14:0] are compared.

Low Power Voltage Reference Scaling Factor Register

Name: ADCREF

Address: 0xFFFF057C

Default Value: Part-specific, factory programmed

Access: Read/write

Function: This MMR allows user code to correct for the initial error of the LPM reference. Value 0x8000 corresponds to no error when compared to the normal mode reference. If the LPM voltage reference is 1% below 1.200 V, the value of ADCREF is approximately 0x7EB9. If the LPM voltage reference is 1% above 1.200 V, the value of ADCREF is approximately 0x8147.

This register corrects the effective value of the LPM reference at the temperature at which the reference is measured during the Analog Devices, Inc., production flow, which is 35°C. There is no change to the temperature coefficient of the LPM reference when using the ADCREF MMR.

This register should not be used if the precision reference is being used in low power mode (if ADCMDE[5] is set).

ADC POWER MODES OF OPERATION

The ADCs can be configured into various reduced or full power modes of operation by configuring ADCMDE[4:3] as appropriate. The ARM7 MCU can itself also be configured in low power modes of operation (POWCON[5:3]). The core power modes are independently controlled and are not related to the ADC power modes described in this section. The ADC power modes of operation are described in more detail in the following paragraphs.

Every I-ADC result can also be compared to a preset threshold level (ADC0TH), as configured via ADCCFG[4:3]. An MCU interrupt is generated if the absolute (sign-independent) value of the ADC result is greater than the preprogrammed comparator threshold level. An extended function of this comparator function allows user code to configure a threshold counter (ADC0THV) that monitors the number of I-ADC results that have occurred above or below the preset threshold level. Again, an ADC interrupt is generated once the threshold counter reaches a preset value (ADC0TCL).

Finally, a 32-bit accumulator (ADC0ACC) function can be configured (ADCCFG[6:5]) allowing the I-ADC to add (or subtract) multiple I-ADC sample results. User code can read the accumulated value directly (via ADC0ACC) without any further software processing.

ADC Startup Procedure

Before beginning the conversion process, the following procedure should be followed:

1. Configure the I-ADC to low power mode (ADC0CON = 0x8007; ADCMDE = 0x09).
2. Delay for 200 μ s.
3. Switch the I-ADC into idle mode (ADCMDE = 0x03), leaving ADC0CON unchanged. If the voltage or temperature channels are to be used, they should be enabled at this time.
4. Delay for 1 ms.
5. Switch ADCMDE to the desired mode, for example, ADCMDE = 0x1.

ADC Normal Power Mode

In normal mode, the current and voltage/temperature channels are fully enabled. The ADC modulator clock is 512 kHz and enables the ADCs to provide regular conversion results at a rate of between 4 Hz and 8 kHz (see Table 40 for the ADCFLT MMR bit designations). Both channels are under full control of the MCU and can be reconfigured at any time. The default ADC update rate for all channels in this mode is 1.0 kHz.

It is worth emphasizing that the I-ADC, V-ADC, and T-ADC channels can be configured to initiate periodic, normal power mode, high accuracy, single conversion cycles before returning to ADC full power-down mode. This flexibility is facilitated under full MCU control via the ADCMDE MMR and ensures that continuous periodic monitoring of battery current, voltage, and temperature settings is feasible, while ensuring the average dc current consumption is minimized.

In ADC normal mode, the PLL must not be powered down.

ADC Low Power Mode

In ADC low power mode, the I-ADC is enabled in a reduced power and reduced accuracy configuration. The ADC modulator clock is driven directly from the on-chip 131 kHz low power oscillator, which allows the ADC to be configured at update rates as low as 1 Hz (ADCFLT). The gain of the ADC in this mode is fixed at 128.

All of the ADC peripheral functions (result counter, digital comparator, and accumulator) described previously in normal power mode can still be enabled in low power mode.

Typically, in low power mode, only the I-ADC is configured to run at a low update rate, continuously monitoring battery current. The MCU is in power-down mode and is powered up only when the I-ADC interrupts the MCU. This happens after the I-ADC detects a current conversion or an accumulated current value that has risen beyond a preprogrammed threshold, setpoint, or a set number of conversions.

It is also possible to select either the ADC normal mode voltage reference or the ADC low power mode voltage reference via ADCMDE[5].

ADC Low Power Plus Mode

In low power plus mode, the I-ADC channel is enabled in a mode almost identical to low power mode (ADCMDE[4:3]). However, in this mode, the I-ADC gain is fixed at 512, and the ADC consumes an additional 200 μ A (approximate) to yield improved noise performance relative to the low power mode setting.

Again, all of the ADC peripheral functions (result counter, digital comparator, and accumulator) described in the ADC Normal Power Mode section can still be enabled in low power plus mode.

As in low power mode, only the I-ADC is configured to run at a low update rate, continuously monitoring battery current. The MCU is in power-down mode and powers up only when the I-ADC interrupts the MCU. This happens after the I-ADC detects a current conversion result, or an accumulated current value has risen beyond a preprogrammed threshold or setpoint.

It is also possible to select either the ADC precision voltage reference or the ADC low power mode voltage reference via ADCMDE[5].

ADC Sinc3 Digital Filter Response

The overall frequency response on all of the ADuC7032-8L ADCs is dominated by the low-pass filter response of the on-chip Sinc3 digital filters. The Sinc3 filters are used to decimate the ADC Σ - Δ modulator output data bit stream to generate a valid 16-bit data result. The digital filter response is identical for all ADCs and is configured via the 16-bit ADC filter (ADCFLT) register that determines the overall throughput rate of the ADCs. The noise resolution of the ADCs is determined by the programmed ADC throughput rate. In the case of the current channel ADC, the noise resolution is determined by throughput rate and selected gain.

The overall frequency response and the ADC throughput is dominated by the configuration of the Sinc3 filter decimation factor (SF) bits (ADCFLT[6:0]) and the averaging factor (AF) bits (ADCFLT[13:8]). Due to limitations on the digital filter internal datapath, there are some limitations on the allowable combinations of SF (Sinc3 decimation factor) and AF (averaging factor) that can be used to generate a required ADC output rate. This restriction limits the minimum ADC update to 4 Hz in normal power mode or 1 Hz in low power mode. The calculation of the ADC throughput rate is detailed in Table 40, the ADCFLT MMR bit designations table, with some examples in Table 41. The restrictions on allowable combinations of AF and SF values are outlined in Table 42.

ADuC7032-8L

By default, the ADCFLT = 0x0007 configures the ADCs for a throughput of 1.0 kHz with all other filtering options (chop, running average, averaging factor, and Sinc3 modify) disabled. A typical filter response based on this default configuration is shown in Figure 19.

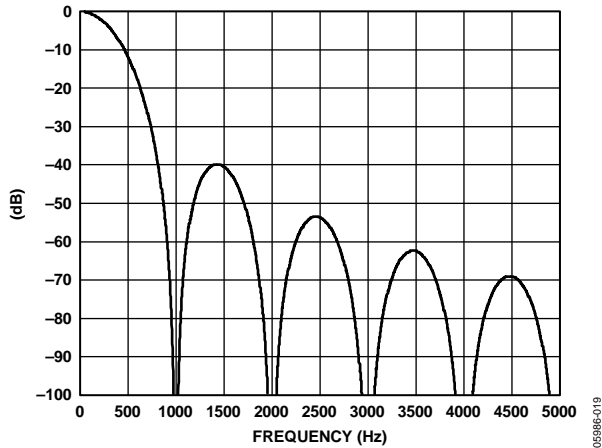

Figure 19. Typical Digital Filter Response at $f_{ADC} = 1.0$ kHz (ADCFLT = 0x0007)

An additional Sinc3 modify bit (ADCFLT[7]) is also available in the ADCFLT register. This bit is set by user code to modify the standard Sinc3 frequency response, increasing the filter stopband rejection by 5 dB approximate. This is achieved by inserting a second notch (NOTCH2) at $f_{NOTCH2} = 1.333 \times f_{NOTCH}$ where f_{NOTCH} is the location of the first notch in the response. There is a slight increase in ADC noise if this bit is active. Figure 20 shows the modified 1 kHz filter response when the Sinc3 modify bit is active. The new notch is clearly visible at 1.33 kHz, as is the improvement in stopband rejection when compared to the standard 1 kHz response shown in Figure 19.

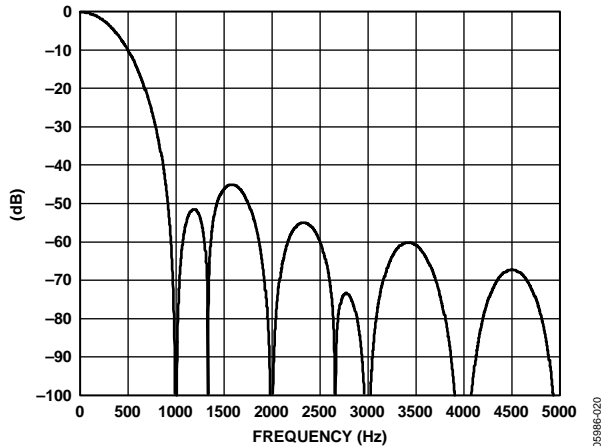

Figure 20. Modified Sinc3 Digital Filter Response at $f_{ADC} = 1.0$ kHz (ADCFLT = 0x0087)

In ADC normal power mode, the maximum ADC throughput rate is 8 kHz, which is configured by setting the SF and AF bits in the ADCFLT MMR to 0, with all other filtering options disabled. This results in 0x0000 written to ADCFLT. A typical 8 kHz filter response, based on these settings, is shown in Figure 21.

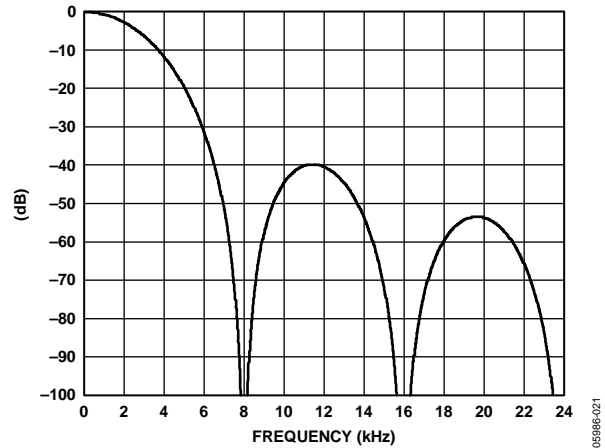

Figure 21. Typical Digital Filter Response at $f_{ADC} = 8$ kHz, (ADCFLT = 0x0000)

A modified version of the 8 kHz filter response can be configured by setting the running average bit (ADCFLT[14]). This has the effect of introducing an additional running average-by-2 filter on all ADC output samples. This further reduces the ADC output noise, and while maintaining an 8 kHz ADC throughput rate, the ADC settling time is increased by one full conversion period. The modified frequency response for this configuration is shown in Figure 22.

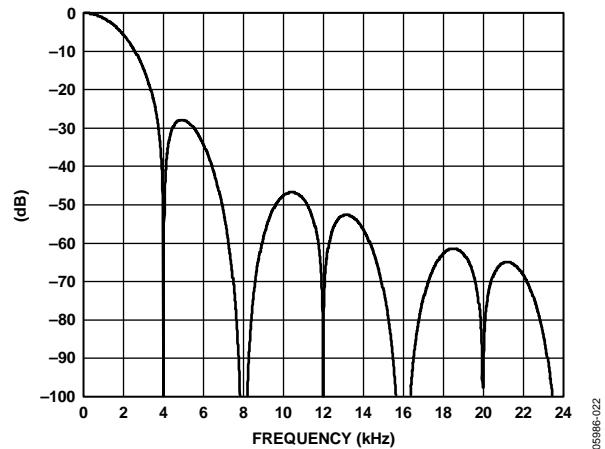

Figure 22. Typical Digital Filter Response at $f_{ADC} = 8$ kHz, (ADCFLT = 0x4000)

At very low throughput rates, the chop bit in the ADCFLT register can be enabled to minimize offset errors and, more importantly, temperature drift in the ADC dc errors. With CHOP enabled, there are again two primary variables (Sinc3 decimation factor and averaging factor) available to allow the user to select an optimum filter response, trading off filter bandwidth against ADC noise.

For example, with the chop bit ADCFLT[15] set to 1, increasing the SF value (ADCFLT[6:0]) to 0x1F (31 decimal) and selecting an AF value (ADCFLT[13:8]) of 0x16 (22 decimal) results in an ADC throughput of 10 Hz. The frequency response in this case is shown in Figure 23.

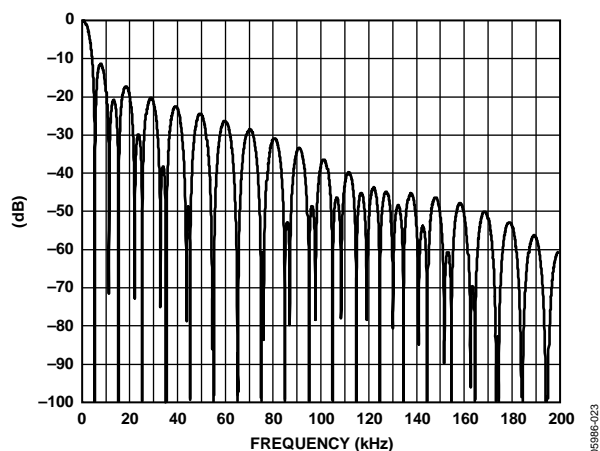

Figure 23. Typical Digital Filter Response at $f_{ADC} = 10$ Hz (ADCFLT = 0x961F)

Changing SF to 0x1D and setting AF to 0x3F, again with the chop bit enabled, configures the ADC into its minimum throughput rate in normal mode of 4 Hz. The digital filter frequency response with this configuration is shown in Figure 24.

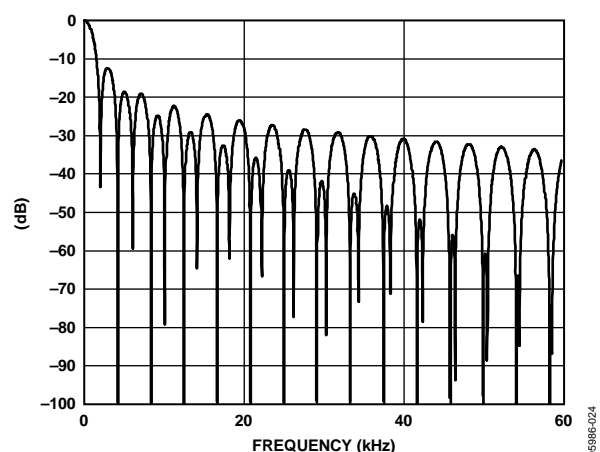

Figure 24. Typical Digital Filter Response at $f_{ADC} = 4$ Hz (ADCFLT = 0xBF1D)

In ADC low power mode, the ADC Σ - Δ modulator clock is no longer driven at 512 kHz but is driven directly from the on-chip low power (131 kHz) oscillator. Subsequently, for the same ADCFLT configurations in normal mode, all filter values should be scaled by a factor of approximately 4. This means that it is possible to configure the ADC for 1 Hz throughput in low power mode. The filter frequency response for this configuration is shown in Figure 25.

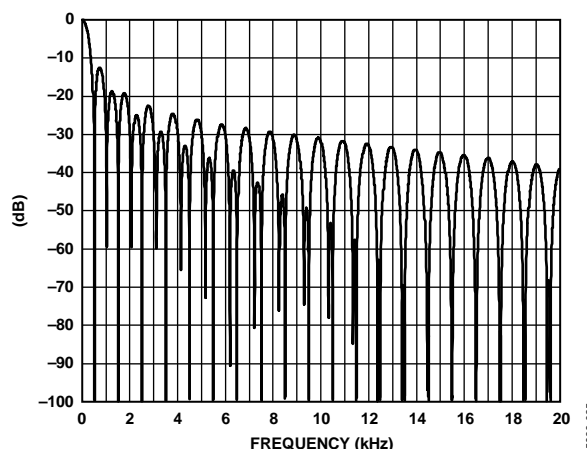

Figure 25. Typical Digital Filter Response at $f_{ADC} = 1$ Hz (ADCFLT = 0xBD1F)

In general, it is possible to program different values of SF and AF in the ADCFLT register and achieve the same ADC update rate. In practical terms, the trade-off with any value of ADCFLT is frequency response vs. ADC noise. For optimum filter response and ADC noise when using combinations of SF and AF, first choose an SF in the range of 16 to 40 (decimal) or 0x10 to 0x28. Then increase the AF value to achieve the required ADC throughput.

Table 44 shows some common ADCFLT configurations.

Table 44. Common ADCFLT Configurations

ADC Mode	SF	AF	Other Configuration	ADCFLT	f_{ADC}	t_{SETTLE}
Normal	0x1D	0x3F	Chop on	0xBF1D	4 Hz	0.5 sec
	0x1F	0x16	Chop on	0x961F	10 Hz	0.2 sec
	0x07	0x00	None	0x0007	1 kHz	3 ms
	0x07	0x00	Sinc3 modify	0x0087	1 kHz	3 ms
	0x03	0x00	Running average	0x4003	2 kHz	2 ms
	0x00	0x00	Running average	0x4000	8 kHz	0.5 ms
Low Power	0x10	0x03	Chop on	0x8310	20 Hz	100 ms
	0x10	0x09	Chop on	0x8910	10 Hz	200 ms
	0x1F	0x3D	Chop on	0xBD1F	1 Hz	2 sec

ADC Calibration

As described in detail in the top level diagrams (Figure 15 and Figure 16), the signal flow through all ADC channels can be described in simple terms.

1. An input voltage is applied through an input buffer (and PGA in the case of the I-ADC) to the Σ - Δ modulator.
2. The modulator output is applied to a programmable digital decimation filter.
3. The filter output result is then averaged if chopping is used.
4. An offset value (ADCxOF) is subtracted from the result.
5. This result is scaled by a gain value (ADCxGN).
6. Finally, the result is formatted as twos complement/offset binary, rounded to 16 bits, or clamped to \pm full scale.

Each ADC has a specific offset and gain correction or calibration coefficient associated with it that is stored in MMR-based offset and gain registers (ADCxOF and ADCxGN). The offset and gain registers can be used to remove offset and gain errors arising within the part, as well as system-level offset and gain errors external to the part.

These registers are configured at power-on with a factory-programmed calibration value. These factory calibration values vary from part to part, reflecting the manufacturing variability of internal ADC circuits. However, these registers can also be overwritten by user code (only if the ADC is in idle mode) and are automatically overwritten if an offset or gain calibration cycle is initiated by the user via the mode bits in the ADCMDE[2:0] MMR. Two types of automatic calibration are available to the user.

Self- (Offset or Gain) Calibration

The ADC generates its calibration coefficient based on an internally generated 0 V in the case of self-offset calibration, and full-scale voltage in the case of self-gain calibration. It should be emphasized that ADC self-calibrations correct for offset and gain errors within the ADC. Self-calibrations cannot compensate for other external errors in the system, for example, shunt-resistor tolerance/drift, external offset voltages, and so on.

System (Offset or Gain) Calibration

The ADC generates its calibration coefficient based on an externally generated zero-scale voltage in the case of system-offset calibration and full-scale voltage in the case of system-gain calibration, which are applied to the external ADC input for the duration of the calibration cycle.

The duration of an offset calibration is one single conversion cycle ($3/f_{\text{ADC}}$ chop off, $2/f_{\text{ADC}}$ chop on) before returning the ADC to idle mode. A gain calibration is a two-stage process that, subsequently, takes twice as long as an offset calibration cycle. Once a calibration cycle is initiated, any ongoing ADC conversion is immediately halted, the calibration is carried out automatically at an ADC update rate programmed into ADCFLT, and the ADC is always returned to idle after any calibration cycle. It is strongly recommended that ADC calibration be initiated at as low an ADC update rate as possible (high SF value in ADCFLT) to minimize the impact of ADC noise during calibration.

Note that in self-calibration mode, ADC0GN must first contain the values for $\text{PGA} = 1$ before a calibration scheme is started.

Using the Offset and Gain Calibration Registers

If the chop bit (ADCFLT[15]) is enabled, internal ADC offset errors are minimized, and an offset calibration may not be required. If chopping is disabled however, an initial offset calibration is required and may need to be repeated, particularly after a large change in temperature.

A gain calibration, particularly in the context of the I-ADC (with internal PGA) may need to be carried out at all relevant system gain ranges, depending on system accuracy requirements. If it is not possible to apply an external full-scale current on all gain ranges, it is possible to apply a lower current and scale the result produced by the calibration. For example, apply a 50% current and then divide the ADC0GN value produced by 2 and write this value back into ADC0GN. Note that there is a lower limit to the input signal that can be applied for a system calibration because the ADC0GN register is only 16 bits. The input span (the difference between the system zero-scale value and the system full-scale value) should be greater than 40% of the nominal full-scale input range, that is, $>40\%$ of $V_{\text{REF}}/\text{GAIN}$.

The on-chip Flash/EE memory can be used to store multiple calibration coefficients that can be copied by user code directly into the relevant calibration registers, as appropriate, based on system configuration. In general, the simplest way to use the calibration registers is to let the ADC calculate the values required as part of the ADC automatic calibration modes.

A factory or end-of-line calibration for the I-ADC is a two-step procedure.

1. Apply 0 A current.

Configure the ADC in the required PGA setting and so on, and write to ADCMDE[2:0] to perform a system zero-scale calibration. This writes a new offset calibration value into ADC0OF.

2. Apply a full-scale current for the selected PGA setting.

Write to ADCMDE to perform a system full-scale calibration. This writes a new gain calibration value into ADC0GN.

Understanding the Offset and Gain Calibration Registers

The output of the average block in the ADC signal flow (described previously after the digital filter and before the offset and gain scaling can be considered to be a fractional number with a span, for a \pm full-scale input of approximately ± 0.75 . The span is less than ± 1.0 because there is attenuation in the modulator to accommodate some overrange capacity on the input signal. The exact value of the attenuation varies slightly from part to part because of manufacturing tolerances.

The offset coefficient is read from the ADC0OF calibration register. This value is a 16-bit twos complement number. The range of this number, in terms of the signal chain, is effectively ± 1.0 . The value of 1 LSB of the ADC0OF register is not, therefore, the same as 1 LSB of ADC0DAT.

A positive value of ADC0OF indicates that the offset is subtracted from the output of the filter, and a negative value of ADC0OF indicates that the offset is added to the output of the filter. The nominal value of this register is 0x0000, indicating zero offset is to be removed. The actual offset of the ADC may vary slightly from part to part and at different PGA gains. The offset within the ADC is minimized if chop mode is active (ADCFLT[15] = 1).

The gain coefficient is a unitless scaling factor. The 16-bit value in this register is divided by 16,384 and then multiplied by the offset-corrected value. The nominal value of this register equals 0x5555, which corresponds to a multiplication factor of 1.3333. This scales the nominal ± 0.75 signal to produce a full-scale output signal of ± 1.0 , which is checked for overflow/underflow and converted to twos complement or unipolar mode, as appropriate, before being output to the data register.

The actual gain, and the required scaling coefficient for zero gain error, vary slightly from part to part, and at different PGA settings and in normal/low power mode. The value downloaded into ADC0GN at power-on/reset represents the scaling factor for a PGA gain = 1. There is some level of gain error if this value is used at different PGA settings. User code can overwrite the calibration coefficients or run ADC calibrations to correct the gain error at the PGA setting in use.

In summary, the simplified ADC transfer function can be described as

$$ADCOUT = \left[\frac{VIN \times PGA}{VREF} - ADCOF \right] \times \frac{ADCGN}{ADCGNNOM}$$

This equation is valid for both the voltage and temperature channel ADCs.

For the current channel ADC

$$ADCOUT = \left[\frac{VIN \times PGA}{VREF} - K \times ADCOF \right] \times \frac{ADCGN}{ADCGNNOM}$$

where K is dependent on the PGA gain setting and ADC mode.

Normal Mode

For PGA gains of 1, 4, 8, 16, 32, and 64, the K factor is 1. For PGA gains of 2 and 128, the K factor is 2. For a PGA gain of 256, the K factor is 4. For a PGA gain of 512, the K factor is 8.

Low Power Mode

The PGA gain is set to 128, and the K factor is 32.

Low Power Plus Mode

The K factor is 8.

In low power and low power plus mode, the K factor doubles if (REG_AVDD)/2 is used as the reference.

ADC DIAGNOSTICS

The ADuC7032-8L features diagnostic capability on all three ADCs.

Current ADC Diagnostics

The ADuC7032-8L features the capability to detect open-circuit conditions on the application board. This is accomplished using the two current sources on IIN+ and IIN-, which is controlled via ADC0CON[14:13].

Note that these current sources have a tolerance of $\pm 30\%$. A PGA gain equal to or greater than 2 (ADC0CON[3:0] \geq 0001) must be used when current sources are enabled.

Temperature ADC Diagnostics

The ADuC7032-8L features the capability to detect open-circuit conditions on the temperature channel inputs. This is accomplished using the two current sources on VTEMP and GND_SW, which is controlled via ADC2CON[14:13].

Note that the current sources have a tolerance of $\pm 30\%$.

POWER SUPPLY SUPPORT CIRCUITS

The ADuC7032-8L incorporates an on-chip, low dropout (LDO) regulator that is driven directly from the battery voltage to generate a 2.6 V internal supply. This 2.6 V supply is then used as the supply voltage for the ARM7 MCU and peripherals, including the precision analog circuits on-chip.

Power-on reset (POR), power supply monitor (PSM), and low voltage flag (LVF) functions are also integrated to ensure safe operation of the MCU, as well as continuous monitoring of the battery power supply.

The POR circuit is designed to handle all battery ramp rates and guarantee full functional operation of the Flash/EE memory-based MCU during power-on and power-down cycles.

As shown in Figure 26, once the supply voltage (VDD) reaches a minimum operating voltage of 3 V, a POR signal keeps the ARM core in reset for 20 ms. This ensures that the regulated power supply voltage (REG_DVDD) supplied to the ARM core and associated peripherals is above the minimum operational voltage to guarantee full functionality. A POR flag is set in the RSTSTA MMR to indicate a POR reset event has occurred.

The ADuC7032-8L also features a power supply monitor (PSM) function. Once enabled via HVCFG0[3], the PSM continuously monitors the voltage at the VDD pin. If this voltage drops below 6.0 V typical, the PSM flag is automatically asserted and can, if the high voltage IRQ is enabled via IRQ/FIQEN[16], generate a system interrupt. An example of this operation is shown in Figure 26.

At voltages below the POR level, an additional low voltage flag can be enabled (HVCFG0[2]). It can be used to indicate that the contents of the SRAM are still valid after a reset event. The operation of the low voltage flag is shown in Figure 26. Once enabled, the status of this bit can be monitored via HVMON[3]. If this bit is set, the SRAM contents are valid. If this bit is cleared, the SRAM contents may have been corrupted.

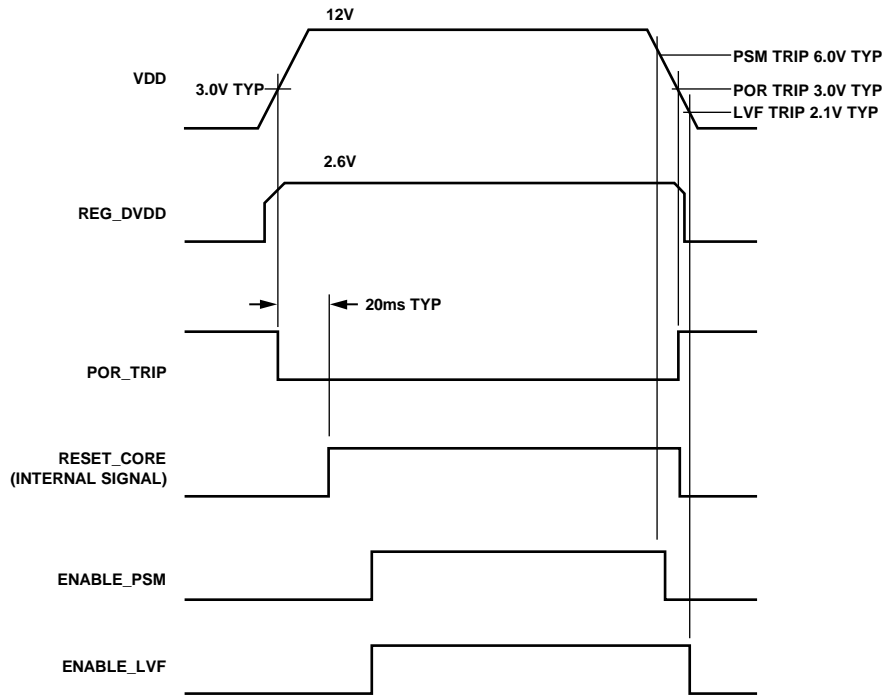

Figure 26. Typical Power-On Cycle

06989c-026

ADuC7032-8L SYSTEM CLOCKS

The ADuC7032-8L integrates a highly flexible clocking system that can be clocked from one of three sources: an integrated on-chip precision oscillator, an integrated on-chip low power oscillator, or an external watch crystal. These three options are shown in Figure 27.

Each of the internal oscillators is divided by four to generate a clock frequency of 32.768 kHz. The PLL locks onto a multiple (625) of 32.768 kHz, supplied by either of the internal oscillators or the external crystal, providing a stable 20.48 MHz clock for the system. The core can operate at this frequency or at binary submultiples of it, allowing power saving if peak performance is not required.

By default, the PLL is driven by the low power oscillator, which generates a 20.48 MHz clock source. The ARM7TDMI core is

driven by a CD divided clock derived from the output of the PLL. By default, the CD divider is configured to divide the PLL output by two, which generates a core clock of 10.24 MHz. The divide factor can be modified to generate a binary weighted divider factor from 1 to 128, which can be altered dynamically by user code.

The ADC is driven by the output of the PLL, divided to give an ADC clock source of 512 kHz. In low-power mode, the ADC clock source is switched from the standard 512 kHz to the low power 131 kHz oscillator.

It should also be noted that the low power oscillator drives both the watchdog and core wake-up timers through a divide-by-4 circuit. A detailed block diagram of the ADuC7032-8L clocking system is shown in Figure 27.

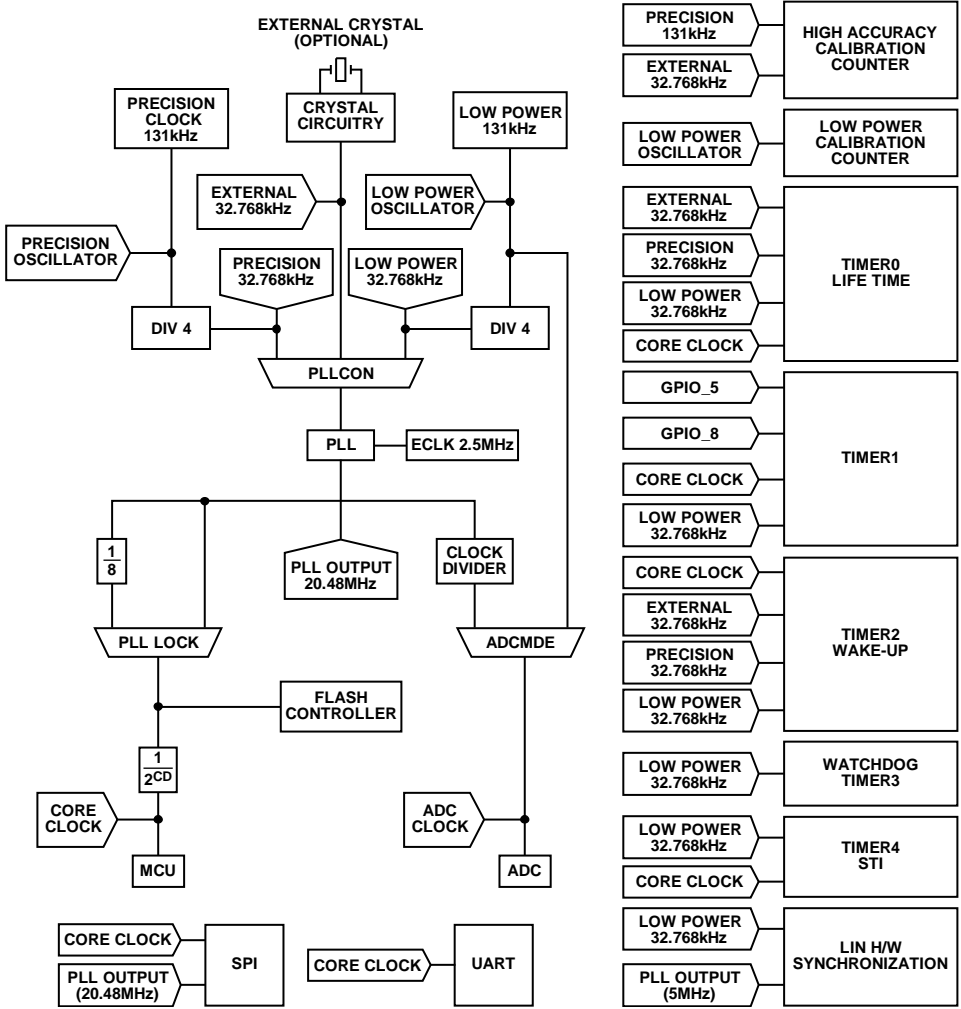

Figure 27. ADuC7032-8L System Clock Generation

ADuC7032-8L

The operating mode, clocking mode, and programmable clock divider are controlled via two MMRs, PLLCON and POWCON; and the status of the PLL is indicated by PLLSTA. PLLCON controls the operating mode of the clock system, and POWCON controls the core clock frequency and the power-down mode. PLLSTA indicates the presence of an oscillator on the XTAL1 pin, the PLL lock status, and the PLL interrupt.

It is recommended that, before the ADuC7032-8L is powered down, the clock source for the PLL be switched to the low power 131 kHz oscillator to reduce wake-up time. The low power oscillator is always active.

When the ADuC7032-8L wakes up from power-down, the MCU core begins executing code once the PLL begins oscillating. This occurs before the PLL has locked to a frequency of 20.48 MHz. To ensure the Flash/EE memory controller is executing with a valid clock, the controller is driven with a PLL output divided by eight clock source while the PLL is locking.

Writing to the POWCON and the PLLCON MMRs

An example of writing to both the POWCON and PLLCON MMRs follows:

```
POWKEY0 = 0x01; // POWCON KEY
POWCON = 0x00; // Full power-down
POWKEY1 = 0xF4; // POWCON KEY
iA1 × iA2; // dummy cycle to clear the pipe line, where iA1 and iA2 are defined as longs
// and are not 0
PLLKEY0 = 0xAA; // PLLCON KEY
PLLCON = 0x0; // Switch to low power oscillator
PLLKEY1 = 0x55; // PLLCON KEY
iA1 × iA2; // dummy cycle to prevent Flash/EE access during clock change
```

PLLSTA Register

Name: PLLSTA

Address: 0xFFFF0400

Default Value: 0x02

Access: Read only

Function: This 32-bit register allows user code to monitor the lock state of the PLL and the status of the external crystal.

Table 45. PLLSTA MMR Bit Designations

Bit	Description
31 to 3	Reserved. Should be written as 0s.
2	XTAL Clock, Read Only. This is a live representation of the current logic level on XTAL1. This allows the user to check if an external clock source is present. If present, this bit alternates high and low at a frequency of 32.768 kHz.
1	PLL Lock Status Bit, Read Only. Set when the PLL is locked and outputting 20.48 MHz. Clear when the PLL is not locked and outputting an F core/8 clock source.
0	PLL Interrupt. Set if the PLL lock status bit signal goes low. Cleared by writing 1 to this bit.

Once the PLL locks, the PLL output is switched from the PLL output divided by eight to the locked PLL output.

If user code requires an accurate PLL output, user code must poll the lock bit (PLLSTA[1]) after wake-up and before resuming normal code execution.

The PLL is locked and executing user code within 2 ms if the PLL is clocked from an active clock source (for example, a low power 131 kHz oscillator) after waking up.

- PLLCON: protected MMR with two 32-bit keys: PLLKEY0, a prewrite key; and PLLKEY1, a postwrite key.
- PLLKEY0 = 0x000000AA
- PLLKEY1 = 0x00000055
- POWCON: protected MMR with two 32-bit keys: POWKEY0, a prewrite key; and POWKEY1, a postwrite key.
- POWKEY0 = 0x00000001
- POWKEY1 = 0x000000F4

PLLCON Prewrite Key PLLKEY0**Name:** PLLKEY0**Address:** 0xFFFF0410**Access:** Write only**Key:** 0x000000AA

Function: PLLCON is a keyed register that requires a 32-bit key value to be written before and after PLLCON. PLLKEY0 is the prewrite key.

PLLCON Postwrite Key PLLKEY1**Name:** PLLKEY1**Address:** 0xFFFF0418**Access:** Write only**Key:** 0x00000055

Function: PLLCON is a keyed register that requires a 32-bit key value to be written before and after PLLCON. PLLKEY1 is the postwrite key.

PLLCON Register**Name:** PLLCON**Address:** 0xFFFF0414**Default Value:** 0x00**Access:** Read/write

Function: This 8-bit register allows user code to dynamically select the PLL source clock from three different oscillator sources.

Table 46. PLLCON MMR Bit Designations

Bit	Description
31 to 3	Reserved. These bits should be written as 0 by user code.
2	Not Used. Must be written as 0 by user software.
1 to 0	PLL Clock Source. ¹ 00 = low power 131 kHz oscillator. 01 = precision 131 kHz oscillator. 10 = external 32.768 kHz crystal. 11 = reserved.

¹ If user code switches MCU clock sources, a dummy MCU cycle should be included after the clock switch is written to PLLCON.

ADuC7032-8L

POWCON Prewrite Key POWKEY0

Name: POWKEY0

Address: 0xFFFFF0404

Access: Write only

Key: 0x00000001

Function: POWCON is a keyed register that requires a 32-bit key value to be written before and after POWCON. POWKEY0 is the prewrite key.

POWCON Postwrite Key POWKEY1

Name: POWKEY1

Address: 0xFFFFF040C

Access: Write only

Key: 0x000000F4

Function: POWCON is a keyed register that requires a 32-bit key value to be written before and after POWCON. POWKEY1 is the postwrite key.

POWCON Register

Name: POWCON

Address: 0xFFFFF0408

Default Value: 0x079

Access: Read/write

Function: This 8-bit register allows user code to dynamically enter various low power modes and modify the CD divider that controls the speed of the ARM7TDMI core.

Table 47. POWCON MMR Bit Designations

Bit	Description
31 to 8	Reserved.
7	Precision 131 kHz Input Enable. Cleared by the user to power down the precision 131 kHz input enable. Set by the user to enable the precision 131 kHz input enable. The precision 131 kHz oscillator must also be enabled via HVCFG0[6]. Setting this bit increases current consumption by approximately 50 μ A and should be disabled when not in use.
6	XTAL Power-Down. Cleared by the user to power down the external crystal circuitry. Set by the user to enable the external crystal circuitry.
5	PLL Power-Down. ¹ This bit is cleared to 0 to power-down the PLL. The PLL cannot be powered down if either the core or peripherals are enabled. Bit 3, Bit 4, and Bit 5 must be cleared simultaneously. Set by default, and set by hardware on a wake-up event.
4	Peripherals Power-Down. ² Cleared to power-down the peripherals. The peripherals cannot be powered down if the core is enabled: Bit 3 and Bit 4 must be cleared simultaneously. LIN can still respond to wake-up events even if this bit is cleared. The wake-up timer (Timer2) can remain active if driven from a low power oscillator, even if this bit is cleared. Set by default, and/or by hardware, on a wake-up event.
3	Core Power-Down. ³ Cleared to power-down the ARM core. Set by default, and set by hardware on a wake-up event.
2 to 0	CD Core Clock Divider Bits. 000 = 20.48 MHz, 48.83 ns 001 = 10.24 MHz, 97.66 ns 010 = 5.12 MHz, 195.31 ns 011 = 2.56 MHz, 390.63 ns 100 = 1.28 MHz, 781.25 ns 101 = 640 kHz, 1.56 μ s 110 = 320 kHz, 3.125 μ s 111 = 160 kHz, 6.25 μ s

¹ Timer peripherals are powered down if driven from the PLL output clock. Timers driven from an active clock source stay in normal power mode.

² The peripherals that are powered down by this bit are as follows: SRAM, Flash/EE memory, and GPIO interfaces; and SPI and UART serial ports.

³ If user code powers down the MCU, a dummy MCU cycle should be included after the power-down command is written to POWCON.

ADUC7032-8L LOW POWER CLOCK CALIBRATION

The low power 131 kHz oscillator can be calibrated using either the precision 131 kHz oscillator or an external 32.768 kHz watch crystal. Two dedicated calibration counters and an oscillator trim register are used to implement this feature.

One counter, nine bits wide, is clocked by either the precision oscillator or the external watch crystal. The second counter, 10 bits wide, is clocked by the low power oscillator, either directly at 131 kHz or via a divide-by-4 block generating 32.768 kHz. The source for each calibration counter should be of the same frequency. The trim register (OSC0TRM) is an 8-bit wide register, the lower four bits of which are user-accessible trim bits. Increasing the value in OSC0TRM decreases the frequency of the low power oscillator; decreasing the value increases the frequency. Based on a nominal frequency of 131 kHz, the typical trim range is 127 kHz to 135 kHz.

The clock calibration mode is configured and controlled by the following MMRs:

- OSC0CON: control bits for calibration
- OSC0STA: calibration status register
- OSC0VAL0: 9-bit counter, Counter 0
- OSC0VAL1: 10-bit counter, Counter 1
- OSC0TRM: oscillator trim register

An example calibration routine is shown in Figure 28. User code configures and enables the calibration sequence via OSC0CON. When the precision oscillator calibration counter, OSC0VAL0, reaches 0x1FF, both counters are disabled.

User code then reads back the value of the low power oscillator calibration counter. There are three possible scenarios.

- OSC0VAL0 = OSC0VAL1: No further action is required.
- OSC0VAL0 > OSC0VAL1: The low power oscillator is running slow. OSC0TRM must be decreased.
- OSC0VAL0 < OSC0VAL1: The low power oscillator is running fast. OSC0TRM must be increased.

When the OSC0TRM has been changed, the routine should be rerun and the new frequency checked.

Using the internal precision 131 kHz oscillator, it takes approximately 4 ms to execute the calibration routine. If the external 32.768 kHz crystal is used, the time increases to 16 ms.

Note that prior to the clock calibration routine being started, it is required that the user switch to either the precision 131 kHz oscillator or the external 32.768 kHz watch crystal as the PLL clock source. If this is not done, the PLL may lose lock each time OSC0TRM is modified. This increases the length of time it takes to calibrate the low power oscillator.

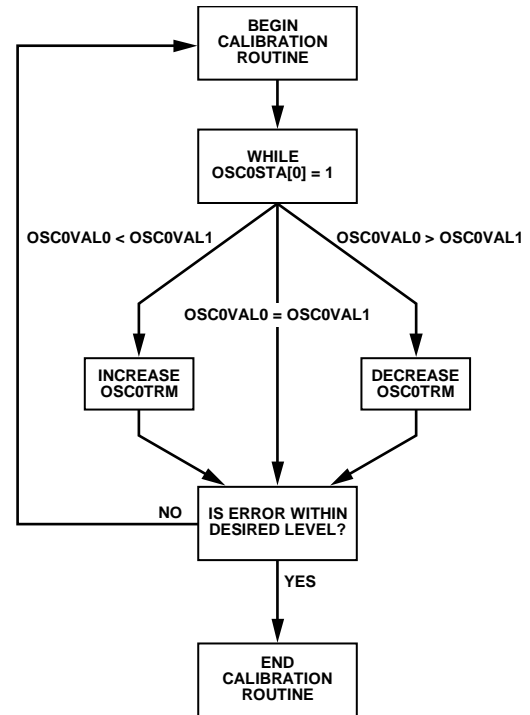

Figure 28. Example OSC0TRM Calibration Routine

05986-028

ADuC7032-8L

OSC0TRM Register

Name: OSC0TRM

Address: 0xFFFF042C

Default Value: 0xX8

Access: Read/write

Function: This 8-bit register controls the low power oscillator trim.

Table 48. OSC0TRM MMR Bit Designations

Bit	Description
7 to 4	Reserved. Should be written as 0s.
3 to 0	User Trim Bits.

OSC0CON Register

Name: OSC0CON

Address: 0xFFFF0440

Default Value: 0x00

Access: Read/write

Function: This 8-bit register controls the low power oscillator calibration routine.

Table 49. OSC0CON MMR Bit Designations

Bit	Description
7 to 5	Reserved. Should be written as 0s.
4	Calibration Source. Set to select external 32.768 kHz crystal. Cleared to select internal precision 131 kHz oscillator.
3	Calibration Reset. Set to reset the calibration counters and disable the calibration logic.
2	Set to clear OSCVAL1.
1	Set to clear OSCVAL0.
0	Calibration Enable. Set to begin calibration. Cleared to abort calibration.

OSC0STA Register

Name: OSC0STA

Address: 0xFFFF0444

Default Value: 0x00

Access: Read only

Function: This 8-bit register reflects the status of the low power oscillator calibration routine.

Table 50. OSC0STA MMR Bit Designations

Bit	Description
31 to 4	Reserved.
3 to 2	Current State of Calibration. 00 = calibration idle, device disabled or completed. 01 = counter enable state. 10 = counting. 11 = finished, return to idle.
1	Calibration Enable. Set to begin calibration. Cleared to abort calibration.
0	Set if calibration is in progress. Cleared if calibration is complete.

OSCOVAL0 Register

Name: OSCOVAL0

Address: 0xFFFF0448

Default Value: 0x0000

Access: Read only

Function: This 9-bit counter is clocked from either the 131 kHz precision oscillator or the 32.768 kHz external crystal.

OSCOVAL1 Register

Name: OSCOVAL1

Address: 0xFFFF044C

Default Value: 0x0000

Access: Read only

Function: This 10-bit counter is clocked from the low power, 131 kHz oscillator.

PROCESSOR REFERENCE PERIPHERALS

INTERRUPT SYSTEM

There are 16 interrupt sources on the ADuC7032-8L that are controlled by the interrupt controller. Most interrupts are generated from the on-chip peripherals such as the ADC, UART, and so on. The ARM7TDMI CPU core recognizes interrupts as only one of two types: a normal interrupt request (IRQ) and a fast interrupt request (FIQ). All the interrupts can be masked separately.

The control and configuration of the interrupt system are managed through nine interrupt-related registers, four dedicated to IRQ and four dedicated to FIQ. An additional MMR is used to select the programmed interrupt source. The bits in each IRQ and FIQ register represent the same interrupt source, as shown in Table 51.

IRQSTA/FIQSTA should be saved immediately upon entering the interrupt service routine (ISR) to ensure that all valid interrupt sources are serviced.

The interrupt generation route through the ARM7TDMI core is shown in Figure 29.

Consider the example of Timer0, which is configured to generate a timeout every 1 ms. After the first 1 ms timeout, FIQSIG/IRQSIG[2] is set and can be cleared only by writing to T0CLR1.

If Timer0 is not enabled in either IRQEN or FIQEN, FIQSTA/IRQSTA[2] is not set and an interrupt does not occur.

If Timer0 is enabled in either IRQEN or FIQEN, then FIQSTA/IRQSTA[2] is set and either an FIQ or an IRQ interrupt occurs.

Note that the IRQ and FIQ interrupt bit definitions in the CPSR control interrupt recognition by the ARM core only, not by the peripherals. For example, if Timer2 is configured to generate an IRQ via IRQEN, the IRQ interrupt bit is set (disabled) in the CPSR, and the ADuC7032-8L is powered down. When an interrupt occurs, the peripherals power up, but the ARM core remains powered down. This is equivalent to POWCON = 0x71. The ARM core can be powered up only by a reset event if this occurs.

Table 51. IRQ/FIQ MMRs Bit Designations

Bit	Description	Comments
0	All interrupts OR'ed (FIQ only).	
1	SWI is not used in IRQEN/CLR and FIQEN/CLR.	
2	Timer0.	See the Timer0—Lifetime Timer section.
3	Timer1.	See the Timer1 section.
4	Timer2 or Wake-Up Timer.	See the Timer2—Wake-Up Timer section.
5	Timer3 or Watchdog Timer.	See the Timer3—Watchdog Timer section.
6	Reserved. Should be written as 0.	
7	LIN Hardware.	See the LIN (Local Interconnect Network) Interface section
8	Flash/EE Interrupt.	See the Flash/EE Control Interface section.
9	PLL Lock.	See the ADUC7032-8L System Clocks section.
10	ADC.	See the 16-Bit, Sigma-Delta Analog-to-Digital Converters section.
11	UART.	See the UART Serial Interface section.
12	SPI Master.	See the Serial Peripheral Interface section.
13	XIRQ0 (GPIO IRQ 0).	See the General-Purpose I/O section.
14	XIRQ1 (GPIO IRQ 1).	See the General-Purpose I/O section.
15	Reserved. Should be written as 0.	
16	IRQ3. High voltage IRQ.	High voltage interrupt; see the High Voltage Peripheral Control Interface section
17	SPI Slave.	
18	XIRQ4 (GPIO IRQ 4).	See the General-Purpose I/O section.
19	XIRQ5 (GPIO IRQ 5).	See the General-Purpose I/O section.

IRQ

The IRQ is the exception signal to enter the IRQ mode of the processor. It is used to service general-purpose interrupt handling of internal and external events.

There are four 32-bit registers dedicated to IRQ.

IRQSIG

Reflects the status of the different IRQ sources. If a peripheral generates an IRQ signal, the corresponding bit in the IRQSIG is set; otherwise, it is cleared. The IRQSIG bits are cleared when the interrupt in the particular peripheral is cleared. All IRQ sources can be masked in the IRQEN MMR. IRQSIG is read only and can be used to poll interrupt sources.

IRQEN

Provides the value of the current enable mask. When the bit is set to 1, the source request is enabled to create an IRQ exception. When the bit is set to 0, the source request is disabled or masked and does not create an IRQ exception.

IRQCLR

A write-only register that allows clearing the IRQEN register to mask an interrupt source. Each bit set to 1 clears the corresponding bit in the IRQEN register without affecting the remaining bits. The pair of registers, IRQEN and IRQCLR, allow independent manipulation of the enable mask without requiring an automatic read-modify-write.

IRQSTA

A read-only register that provides the current enabled IRQ source status (effectively a Logic AND of the IRQSIG and IRQEN bits). When the bit is set to 1, that source generates an active IRQ request to the ARM7TDMI core. There is no priority encoder or interrupt vector generation. This function is implemented in software in a common interrupt handler routine. All 32 bits are logically OR'ed to create a single IRQ signal to the ARM7TDMI core.

FIQ

The fast interrupt request (FIQ) is the exception signal to enter the FIQ mode of the processor. It is provided to service data transfer or communication channel tasks with low latency. The FIQ interface is identical to the IRQ interface, providing the second level interrupt (highest priority). Four 32-bit registers are dedicated to FIQ, FIQSIG, FIQEN, FIQCLR, and FIQSTA.

Bit 31 to Bit 1 of FIQSTA are logically OR'ed to create the FIQ signal to the core and to Bit 0 of both the FIQ and IRQ registers (FIQ source).

The logic for FIQEN and FIQCLR does not allow an interrupt source to be enabled in both IRQ and FIQ masks. A bit set to 1 in FIQEN, as a side effect, clears the same bit in IRQEN.

A bit set to 1 in IRQEN, as a side effect, clears the same bit in FIQEN. An interrupt source can be disabled in both IRQEN and FIQEN masks.

Programmed Interrupts

Because the programmed interrupts are nonmaskable, they are controlled by another register, SWICFG, which writes into both IRQSTA and IRQSIG registers and/or FIQSTA and FIQSIG registers at the same time.

The 32-bit register dedicated to software interrupt is SWICFG, described in Table 52. This MMR allows the control of programmed source interrupt.

Table 52. SWICFG MMR Bit Designations

Bit	Description
31 to 3	Reserved.
2	Programmed Interrupt FIQ. Setting/clearing this bit corresponds to setting/clearing Bit 1 of FIQSTA and FIQSIG.
1	Programmed Interrupt IRQ. Setting/clearing this bit corresponds to setting/clearing Bit 1 of IRQSTA and IRQSIG.
0	Reserved.

Note that to be detected by the interrupt controller and to be detected by the user in the IRQSTA and FIQSTA registers, any interrupt signal must be active for at least the minimum interrupt latency time.

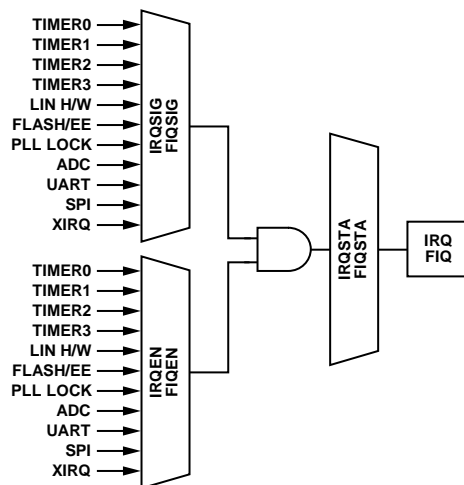

Figure 29. Interrupt Structure

05986-029

TIMERS

The ADuC7032-8L features four general-purpose timers/counters.

- Timer0, or lifetime timer
- Timer1
- Timer2 or wake-up timer
- Timer3 or watchdog timer

The four timers in their normal mode of operation can be in either free running mode or periodic mode.

Timers are started by writing data to the control register of the corresponding timer (TxCON). The counting mode and speed depend on the configuration chosen in TxCON.

In normal mode, an IRQ is generated each time the value of the counter reaches 0 when counting down, or each time the counter value reaches full scale when counting up. An IRQ can be cleared by writing any value to clear the register of that particular timer (TxCLRI).

The three timers in their normal mode of operation can be either free-running or periodic.

In free-running mode, starting with the value in the TxLD register, the counter decrements/increments from the maximum/minimum value until zero/full scale and starts again at the maximum/minimum value. This means that, in free-running mode, TxVAL is not reloaded when the relevant interrupt bit is set but the count simply rolls over as the counter underflows or overflows.

In periodic mode, the counter decrements/increments from the value in the load register (TxLD MMR) until zero/full scale starts again from this value. This means when the relevant interrupt bit is set, TxVAL is reloaded with TxLD and counting starts again from this value.

Loading the TxLD register with zero is not recommended. The value of a counter can be read at any time by accessing its value register (TxVAL).

In addition, Timer0 and Timer1 each has a capture register (T0CAP and T1CAP, respectively) that can hold the value captured by an enabled IRQ event. The IRQ events are described in Table 53.

Table 53. Timer Event Capture

Bit	Description	Comments
0	Timer0.	See the Timer0—Lifetime Timer section.
1	Timer1.	See the Timer1 section.
2	Timer2 or Wake-Up Timer.	See the Timer2—Wake-Up Timer section.
3	Timer3 or Watchdog Timer.	See the Timer3—Watchdog Timer section.
4	Reserved.	Should be written as 0.
5	LIN Hardware.	See the LIN (Local Interconnect Network) Interface section.
6	Flash/EE Interrupt.	See the Flash/EE Control Interface section.
7	PLL Lock.	See the ADuC7032-8L System Clocks section.
8	ADC.	See the 16-Bit, Sigma-Delta Analog-to-Digital Converters section.
9	UART.	See the UART Serial Interface section.
10	SPI Master.	See the Serial Peripheral Interface section.
11	XIRQ0 (GPIO IRQ 0).	See the General-Purpose I/O section.
12	XIRQ1 (GPIO IRQ 1).	See the General-Purpose I/O section.
13	Reserved.	Should be written as 0.
14	IRQ3 High Voltage IRQ.	See the High Voltage Peripheral Control Interface section.
15	SPI Slave.	
16	XIRQ4 (GPIO IRQ 4).	See the General-Purpose I/O section.
17	XIRQ5 (GPIO IRQ 5).	See the General-Purpose I/O section.

SYNCHRONIZATION OF TIMERS ACROSS ASYNCHRONOUS CLOCK DOMAINS

The block diagram in Figure 30 shows the interface between user timer MMRs and the core timer blocks. User code can access all timer MMRs directly, including TxLD, TxVAL, TxCON, and TxCLR. Data must then transfer from these MMRs to the core timers (T0, T1, T2, T3, and T4) within the timer subsystem. These core timers are buffered from the user MMR interface by the synchronization (SYNC) block.

The principal of the SYNC block is to provide a method that ensures that data and other required control signals can cross asynchronous clock domains correctly. An example of asynchronous clock domains is the MCU running on the 10 MHz core clock, and Timer2 running on the low power oscillator of 32 kHz.

As shown in Figure 30, the MMR logic and core timer logic reside in separate and asynchronous clock domains. Any data coming from the MMR core clock domain and being passed to the internal timer domain must be synchronized to the internal timer clock domain to ensure it is latched correctly into the core timer clock domain. This is achieved by using two flip-flops, as shown in Figure 31, to not only synchronize, but also to double buffer the data and thereby ensure data integrity in the timer clock domain.

As a result of the synchronization block, while timer control data is latched almost immediately (with the fast, core clock) in the MMR clock domain, this data in turn does not reach the core timer logic for at least two periods of the selected internal timer domain clock.

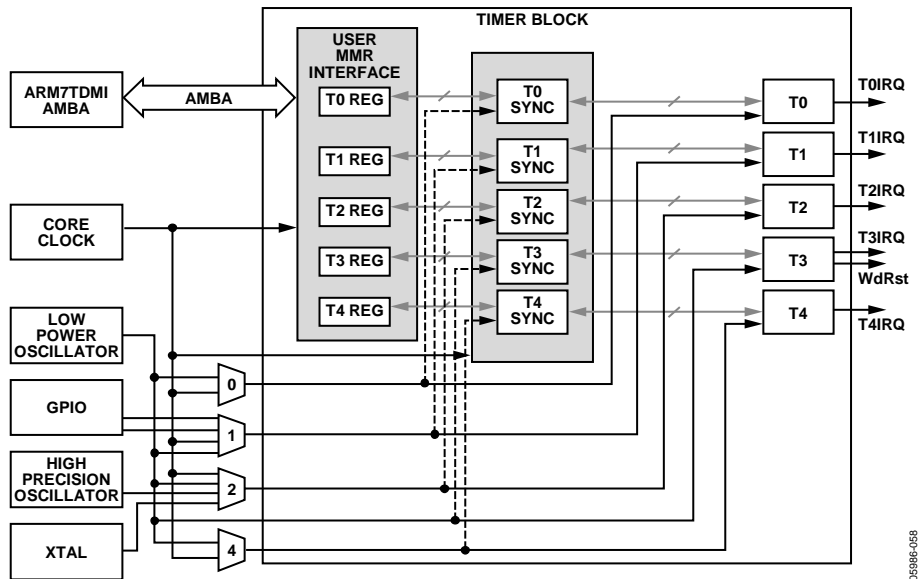

Figure 30. Timer Block Diagram

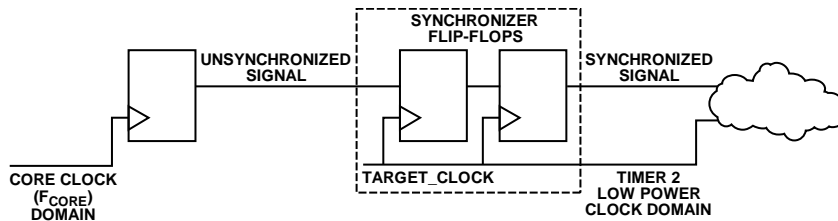

Figure 31. Synchronizer for Signals Crossing Clock Domains

PROGRAMMING THE TIMERS

Understanding synchronization across timer domains also requires that the user code carefully program the timers when stopping or starting them. The recommended code controls the timer block when stopping and starting the timers and when using different clock domains. This can be critical, especially if timers are enabled to generate an IRQ or FIQ exception; Timer2 is used as an example.

Halting Timer2

When halting Timer2, it is recommended that the IRQEN bit for Timer2 be masked (using IRQCLR). This prevents unwanted IRQs from generating an interrupt in the MCU before the T2CON control bits have been latched in the Timer2 internal logic.

```
IRQCLR = WAKEUP_TIMER_BIT;    //Masking interrupts
T2CON=0x00;                   //Halting the timer
```

Starting Timer2

When starting Timer2, it is recommended to first load Timer2 with the required TxLD value. Next, start the timer by setting the T2CON bits as required. This enables the timer, but only when the T2CON bits have been latched internally in the Timer2 clock domain. Therefore, it is advised that a delay of more than three clock periods (that is, 100 μ s for a 32 kHz timer clock source) be inserted to allow both the T2LD value and the T2CON value to be latched through the synchronization logic and reach the Timer2 domain.

After the delay, it is recommended that any (inadvertent) Timer2 interrupts are now cleared using T2CLR = 0x00. Finally, the Timer2 system interrupt can be unmasked by setting the appropriate bit in the IRQEN MMR. An example of this code is as follows, with the assumption that Timer2 is halted:

Example Code

```
T2LD = 0x1;                   //Reload Timer
T2CON = 0x02CF;               //Enable T2-Low
Power Osc, 32768 prescaler
Delay(100us);                 //Include Delay to
ensure T2CON bits take effect
T2CLR = 0;                    //*ClearTimerIrq
IRQEN = WAKEUP_TIMER_BIT;     //Unmask Timer2
```

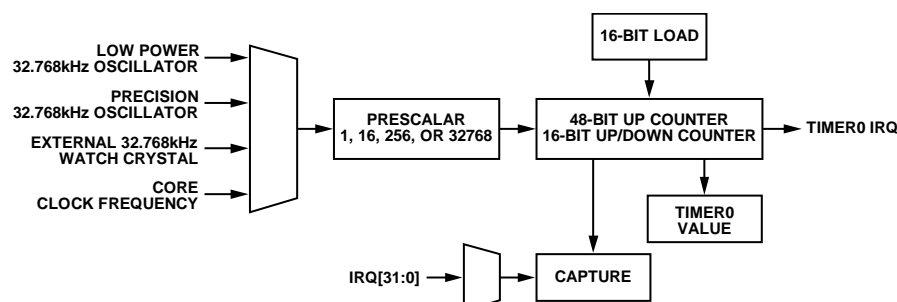

Figure 32. Timer0 Block Diagram

TIMER0—LIFETIME TIMER

Timer0 is a general-purpose 48-bit count-up, or a 16-bit count-up/count-down timer with a programmable prescaler. Timer0 can be clocked from either the core clock, the low power 32.768 kHz oscillator, the precision 32.768 kHz oscillator, or an external 32.768 kHz crystal with a prescaler of 1, 16, 256, or 32,768. This gives a minimum resolution of 48.83 ns when the core is operating at 20.48 MHz, and with a prescaler of 1.

In 48-bit mode, Timer0 counts up from zero. The current counter value can be read from T0VAL0 and T0VAL1.

In 16-bit mode, Timer0 can count up or count down. A 16-bit value can be written to T0LD that is loaded into the counter. The current counter value can be read from T0VAL0. Timer0 has a capture register (T0CAP) that can be triggered by a selected IRQ source initial assertion. Once triggered, the current timer value is copied to T0CAP, and the timer keeps running. This feature can be used to determine the assertion of an event with more accuracy than by servicing an interrupt alone.

Timer0 reloads the value from T0LD either when Timer0 overflows, or immediately when T0CLR is written.

The Timer0 interface consists of the following six MMRs:

- T0LD: 16-bit register that holds the 16-bit value that is loaded into the counter. Available only in 16-bit mode
- T0CAP: 16-bit register that holds the 16-bit value captured by an enabled IRQ event. Available only in 16-bit mode.
- T0VAL0 and T0VAL1: 16-bit and 32-bit registers that hold the 16 least significant bits (LSBs) and 32 most significant bits (MSBs), respectively. T0VAL0 and T0VAL1 are read only. In 16-bit mode, 16-bit T0VAL0 is used. In 48-bit mode, both the 16-bit T0VAL0 and 32-bit T0VAL1 are used.
- T0CLR: 8-bit register. Writing any value to this register clears the interrupt. Available only in 16-bit mode.
- T0CON: configuration MMR described in Table 54.

ADuC7032-8L

Timer0 Value Register

Name: T0VAL0/T0VAL1

Address: 0xFFFF0304, 0xFFFF0308

Default Value: 0x0000, 0x00000000

Access: Read only

Function: These are 16-bit and 32-bit registers that hold the 16 least significant bits and 32 most significant bits, respectively. T0VAL0 and T0VAL1 are read only. In 16-bit mode, 16-bit T0VAL0 is used. In 48-bit mode, both 16-bit T0VAL0 and 32-bit T0VAL1 are used.

Timer0 Capture Register

Name: T0CAP

Address: 0xFFFF0314

Default Value: 0x0000

Access: Read/write

Function: This 16-bit register holds the 16-bit value captured by an enabled IRQ event. It is available only in 16-bit mode.

Timer0 Control Register

Name: T0CON

Address: 0xFFFF030C

Default Value: 0x00000000

Access: Read/write

Function: This 32-bit MMR configures the mode of operation of Timer0.

Timer0 Load Register

Name: T0LD

Address: 0xFFFF0300

Default Value: 0x0000

Access: Write once only

Function: This 16-bit register holds the 16-bit value that is loaded into the counter. It is available only in 16-bit mode.

Timer0 Clear Register

Name: T0CLR1

Address: 0xFFFF0310

Access: Write only

Function: This 8-bit, write-only MMR is written (with any value) by user code to refresh (reload) Timer0.

Table 54. T0CON MMR Bit Designations

Bit	Description
31 to 18	Reserved. This bit is reserved and should be written as 0 by user code.
17	Event Select Bit. Set by the user to enable time capture of an event. Cleared by the user to disable time capture of an event.
16 to 12	Event Select Range, 0 to 31. The events are described in Table 53.
11	Reserved. This bit is reserved and should be written as 0 by user code.
10 to 9	Clock Select. 00 = core clock (default). 01 = low power 32.768 kHz oscillator. 10 = external 32.768 kHz watch crystal. 11 = precision 32.768 kHz oscillator.
8	Count Up. Available only in 16-bit mode. Set by user for Timer0 to count up. Cleared by user for Timer0 to count down (default).
7	Timer0 Enable Bit. Set by user to enable Timer0. Cleared by user to disable Timer0 (default).
6	Timer0 Mode. Set by user to operate in periodic mode. Cleared by user to operate in free running mode (default).
5	Reserved. This bit is reserved and should be written as 0 by user code.
4	Timer0 Mode of Operation. 0 = 16-bit operation (default). 1 = 48-bit operation.
3 to 0	Prescaler. 0000 = source clock/1 (default). 0100 = source clock/16. 1000 = source clock/256. 1111 = source clock/32,768.

TIMER1

Timer1 is a 32-bit general-purpose timer, count-down or count-up, with a programmable prescaler. The prescaler source can be the low power 32.768 kHz oscillator, the core clock, or one of two external GPIOs. This source can be scaled by a factor of 1, 16, 256, or 32,768. This gives a minimum resolution of 48.83 ns when operating at CD zero; the core is operating at 20.48 MHz, and with a prescaler of 1 (ignoring external GPIO).

The counter can be formatted as a standard 32-bit value or as hours:minutes:seconds:hundreths.

Timer1 has a capture register (T1CAP) that can be triggered by a selected IRQ source initial assertion. Once triggered, the current timer value is copied to T1CAP and the timer keeps running. This feature can be used to determine the assertion of an event with increased accuracy.

The Timer1 interface consists of five MMRs.

- T1LD, T1VAL, and T1CAP are 32-bit registers that hold 32-bit unsigned integers. T1VAL and T1CAP are read only.
- T1CLRI is an 8-bit register. Writing any value to this register clears the Timer1 interrupt.
- T1CON is the configuration MMR described in Table 55.

Timer1 features a postscalar. This allows the user to count between 1 and 256 the number of Timer1 timeouts. To activate the postscalar, the user sets Bit 23 and writes the desired number to count into Bit 24 to Bit 31 of T1CON. Once that number of timeouts has been reached, Timer1 generates an interrupt if T1CON[18] is set.

Note that if the part is in a low power mode and Timer1 is clocked from the GPIO or low power oscillator source, Timer1 continues to operate.

Timer1 reloads the value from T1LD either when Timer1 overflows or immediately when T1CLRI is written.

Timer1 Load Register

Name: T1LD

Address: 0xFFFF0320

Default Value: 0x00000

Access: Write only

Function: This 32-bit register holds the 32-bit value that is loaded into the counter.

Timer1 Clear Register

Name: T1CLRI

Address: 0xFFFF032C

Access: Write only

Function: This 32-bit, write-only MMR is written (with any value) by user code to clear the interrupt.

Timer1 Value Register

Name: T1VAL

Address: 0xFFFF0324

Default Value: 0xFFFFFFFF

Access: Read only

Function: This 32-bit register holds the current value of Timer1.

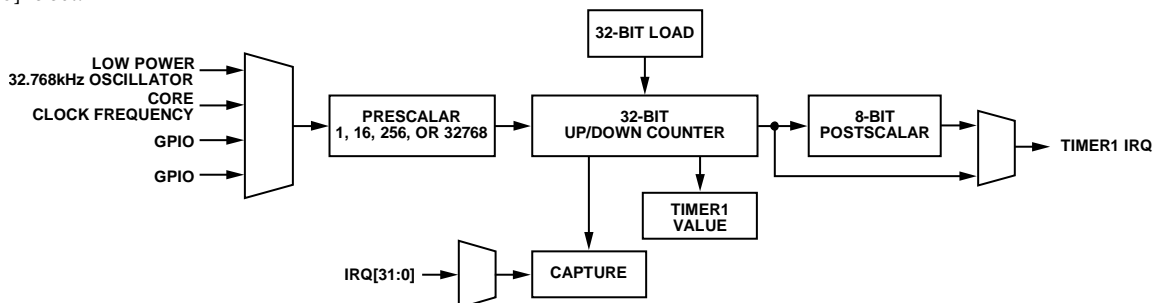

Figure 33. Timer1 Block Diagram

05986-C01

ADuC7032-8L

Timer1 Capture Register

Name: T1CAP

Address: 0xFFFF0330

Default Value: 0x00000000

Access: Read/write

Function: This 32-bit register holds the 32-bit value captured by an enabled IRQ event.

Timer1 Control Register

Name: T1CON

Address: 0xFFFF0328

Default Value: 0x01000000

Access: Read/write

Function: This 32-bit MMR configures the mode of operation of Timer1.

Table 55. T1CON MMR Bit Designations

Bit	Description
31 to 24	Timer1 8-Bit Postscalar. By writing to these 8 bits, a value is loaded into the postscalar. Writing 0 to these bits is interpreted as a 1. By reading these 8 bits, the current value of the counter is loaded.
23	Timer1 Enable Postscalar. Set to enable Timer1 postscalar. If enabled, an interrupt is generated after T1CON[31:24] periods, as defined by T1LD. Cleared to disable Timer1 postscalar.
22 to 20	Reserved. This bit is reserved and should be written as 0 by user code.
19	Postscalar Compare Flag. Set if the number of Timer1 overflows is equal to the number written to the postscalar.
18	Timer1 Interrupt Source. Set to select interrupt generation from postscalar counter. Cleared to select interrupt generation direct from Timer1.
17	Event Select Bit. Set by user to enable time capture of an event. Cleared by user to disable time capture of an event.
16 to 12	Event Select Range, 0 to 31. The events are described in Table 53.
11 to 9	Clock Select. 000 = core clock (default). 001 = low power 32.768 kHz oscillator. 010 = GPIO_8. 011 = GPIO_5.
8	Count Up. Set by user for Timer1 to count up. Cleared by user for Timer1 to count down (default).
7	Timer1 Enable Bit. Set by user to enable Timer1. Cleared by user to disable Timer1 (default).
6	Timer1 Mode. Set by user to operate in periodic mode. Cleared by user to operate in free-running mode (default).
5 to 4	Format. 00 = binary (default). 01 = reserved. 10 = hours:minutes:seconds:hundredths—23 hours to 0 hour. 11 = hours:minutes:seconds:hundredths—255 hours to 0 hour.
3 to 0	Prescaler. 0000 = source clock/1 (default). 0100 = source clock/16. 1000 = source clock/256. 1111 = source clock/32,768.

TIMER2—WAKE-UP TIMER

Timer2 is a 32-bit wake-up timer, count-down or count-up, with a programmable prescaler. The prescaler is clocked directly from one of four clock sources, namely, the core clock (default selection), the low power 32.768 kHz oscillator, the external 32.768 kHz watch crystal, or the precision 32.768 kHz oscillator. The selected clock source can be scaled by a factor of 1, 16, 256, or 32,768. The wake-up timer continues to run when the core clock is disabled. This gives a minimum resolution of 48.83 ns when operating at CD zero; the core is operating at 20.48 MHz, and with a prescaler of 1. Capture of the current timer value is enabled if the Timer2 interrupt is enabled via IRQEN[4].

The counter can be formatted as plain 32-bit value or as hours:minutes:seconds:hundreths.

Timer2 reloads the value from T2LD either when TIMER2 overflows, or immediately when T2CLRI is written.

The Timer2 interface consists of four MMRs.

- T2LD and T2VAL: 32-bit registers that hold 32-bit unsigned integers. T2VAL is read only.
- T2CLRI: 8-bit register. Writing any value to this register clears the Timer2 interrupt.
- T2CON: configuration MMR described in Table 56.

Timer2 Load Register

Name: T2LD

Address: 0xFFFF0340

Default Value: 0x00000000

Access: Read/write

Function: This 32-bit register holds the 32-bit value loaded into the counter.

Timer2 Clear Register

Name: T2CLRI

Address: 0xFFFF034C

Access: Write only

Function: This 8-bit, write-only MMR is written (with any value) by user code to clear the interrupt.

Timer2 Value Register

Name: T2VAL

Address: 0xFFFF0344

Default Value: 0xFFFFFFFF

Access: Read only

Function: This 32-bit register holds the current value of Timer2.

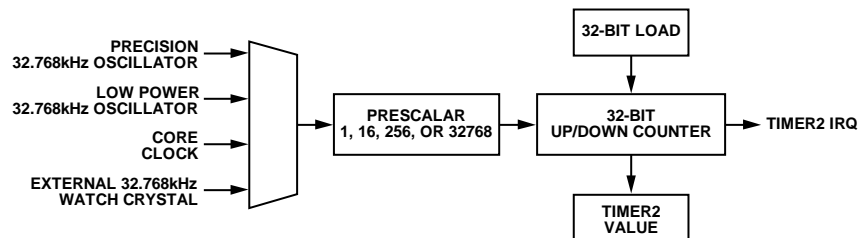

Figure 34. Timer2 Block Diagram

ADuC7032-8L

Timer2 Control Register

Name: T2CON

Address: 0xFFFF0348

Default Value: 0x0000

Access: Read/write

Function: This 32-bit MMR configures the mode of operation of Timer2.

Table 56. T2CON MMR Bit Designations

Bit	Description
31 to 11	Reserved.
10 to 9	Clock Source Select. 00 = core clock (default). 01 = low power 32.768 kHz oscillator. 10 = external 32.768 kHz watch crystal. 11 = precision 32.768 kHz oscillator.
8	Count Up. Set by user for Timer2 to count up. Cleared by user for Timer2 to count down (default).
7	Timer2 Enable Bit. Set by user to enable Timer2. Cleared by user to disable Timer2 (default).
6	Timer2 Mode. Set by user to operate in periodic mode. Cleared by user to operate in free running mode (default).
5 to 4	Format. 00 = binary (default). 01 = reserved. 10 = hours:minutes:seconds:hundredths—23 hours to 0 hour. 11 = hours:minutes:seconds:hundredths—255 hours to 0 hour.
3 to 0	Prescaler. 0000 = source clock/1 (default). 0100 = source clock/16. 1000 = source clock/256 (should be used in conjunction with Timer2 Format 10 and Timer2 Format 11). 1111 = source clock/32,768.

TIMER3—WATCHDOG TIMER

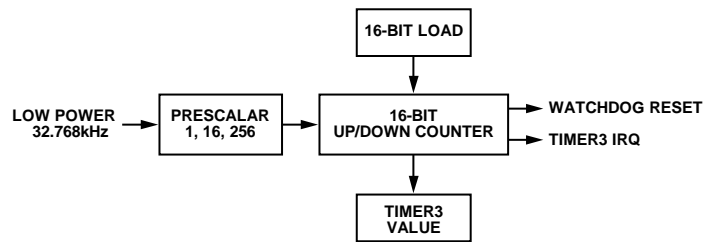

Figure 35. Timer3 Block Diagram

Timer3 has two modes of operation: normal mode and watchdog mode. The watchdog timer is used to recover from an illegal software state. Once enabled, it requires periodic servicing to prevent it from forcing a reset of the processor.

Timer3 reloads the value from T3LD either when TIMER3 overflows, or immediately when T3CLRI is written.

Normal Mode

Timer3 in normal mode is identical to Timer0 in 16-bit mode of operation, except for the clock source. The clock source is the low power 32.768 kHz oscillator and can be scaled by a factor of 1, 16, or 256. Timer3 also features a capture facility that allows the capture of the current timer value if the Timer2 interrupt is enabled via IRQEN[5].

Watchdog Mode

Watchdog mode is entered by setting T3CON[5]. Timer3 decrements from the timeout value present in the T3LD register until the value reaches 0. The maximum timeout is 512 seconds, using the maximum prescaler of 1/256 and full scale in T3LD.

User software should not configure a timeout period of less than 30 ms. This is to avoid any conflict with Flash/EE memory page erase cycles, which require 20 ms to complete a single page erase cycle.

If T3VAL reaches 0, a reset or an interrupt occurs, depending on T3CON[1]. To avoid a reset or an interrupt event, any value must be written to T3CLRI before T3VAL reaches 0. This reloads the counter with T3LD and begins a new timeout period.

When watchdog mode is entered, T3LD and T3CON are write-protected. These two registers cannot be modified until any reset event resets the watchdog timer.

Timer3 is automatically halted during JTAG debug access and recommences counting only when JTAG relinquishes control of the ARM7 core. By default, Timer3 continues to count during power-down. This can be disabled by setting Bit 0 in T3CON. It is recommended that the default value be used, that is, that the watchdog timer continue to count during power-down.

Timer3 Interface

The Timer3 interface consists of four MMRs.

- T3CON is the configuration MMR described in Table 57.
- T3LD and T3VAL are 16-bit registers (Bit 0 to Bit 15) that hold 16-bit unsigned integers. T3VAL is read only.
- T3CLRI is an 8-bit register. Writing any value to this register clears the Timer3 interrupt in normal mode or resets a new timeout period in watchdog mode.

Timer3 Load Register

Name: T3LD

Address: 0xFFFF0360

Default Value: 0x0040

Access: Read/write

Function: This 16-bit MMR holds the Timer3 reload value.

Timer3 Value Register

Name: T3VAL

Address: 0xFFFF0364

Default Value: 0x0040

Access: Read only

Function: This 16-bit, read-only MMR holds the current Timer3 count value.

Timer3 Clear Register

Name: T3CLRI

Address: 0xFFFF036C

Access: Write only

Function: This 8-bit, write-only MMR is written (with any value) by user code to refresh (reload) Timer3 in watchdog mode to prevent a watchdog timer reset event. This register must be written with a specific value (generated by user code, based on a polynomial equation) to refresh the watchdog timer and prevent a watchdog reset. In normal mode, writing any value to this MMR clears the interrupt.

ADuC7032-8L

Timer3 Control Register

Name: T3CON

Address: 0xFFFF0368

Default Value: 0x0000

Access: Read/write once only

Function: This 16-bit MMR configures the mode of operation of Timer3, as shown in Table 57.

Table 57. T3CON MMR Bit Designations

Bit	Description
15 to 9	Reserved. These bits are reserved and should be written as 0 by user code.
8	Count Up/Count Down Enable. Set by user code to configure Timer3 to count up. Cleared by user code to configure Timer3 to count down.
7	Timer3 Enable. Set by user code to enable Timer3. Cleared by user code to disable Timer3.
6	Timer3 Operating Mode. Set by user code to configure Timer3 to operate in periodic mode. Cleared by user to configure Timer3 to operate in free-running mode.
5	Watchdog Timer Mode Enable. Set by user code to enable watchdog mode. Cleared by user code to disable watchdog mode.
4	Reserved. This bit is reserved and should be written as 0 by user code.
3 to 2	Timer3 Clock (32.768 kHz) Prescaler. 00 = source clock/1 (default). 01 = source clock/16. 10 = source clock/256. 11 = reserved.
1	Watchdog Timer IRQ Enable. Set by user code to produce an IRQ instead of a reset when the watchdog reaches 0. Cleared by user code to disable the IRQ option.
0	PD_OFF. Set by user code to stop Timer3 when the peripherals are powered down via Bit 4 in the POWCON MMR. Cleared by user code to enable Timer3 when the peripherals are powered down via Bit 4 in the POWCON MMR.

GENERAL-PURPOSE I/O

The ADuC7032-8L features nine general-purpose bidirectional I/O pins (GPIO). In general, many of the GPIO pins have multiple functions that can be configured by user code. By default, the GPIO pins are configured in GPIO mode. All GPIO pins have an internal pull-up resistor, their sink capability is 0.8 mA, and they can source 0.1 mA.

The nine GPIOs are grouped into three ports: Port0, Port1, and Port2. Port0 is five bits wide. Port1 and Port2 are both two bits wide. The GPIO assignment within each port is shown in Table 58.

A typical GPIO structure is shown in Figure 36.

External interrupts are present on GPIO_0, GPIO_5, GPIO_7, and GPIO_8. These interrupts are level triggered and are active high. These interrupts are not latched; therefore, the interrupts source must be present until either IRQSTA or FIQSTA is interrogated.

The interrupt source must be active for at least one CD-divided core clock to guarantee recognition.

All port pins are configured and controlled by four sets (one set for each port) of four port-specific MMRs.

- GPxCON: Portx control register
- GPxDAT: Portx configuration and data register
- GPxSET: Portx data set
- GPxCLR: Portx data clear

where x corresponds to the port number (0, 1, or 2).

During normal operation, user code can control the function and state of the external GPIO pins via these general-purpose registers. All GPIO pins retain their external high or low during power-down (POWCON) mode.

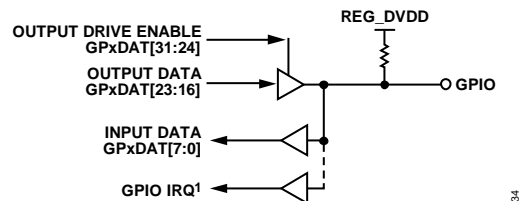

¹ONLY AVAILABLE ON GPIO_0, GPIO_5, GPIO_7, AND GPIO_8.

Figure 36. ADuC7032-8L GPIO

05986-034

ADuC7032-8L

Table 58. External GPIO Pin to Internal Port Signal Assignments

Port	GPIO Pin	Port Signal	Functionality (Defined by GPxCON)
Port0	GPIO_0	P0.0	General-Purpose I/O.
		IRQ0	External Interrupt Request 0.
		SS	Slave Select I/O for SPI.
	GPIO_1	P0.1 SCLK	General-Purpose I/O. Serial Clock I/O for SPI.
	GPIO_2	P0.2 MISO	General-Purpose I/O. Master Input, Slave Output for SPI.
Port1	GPIO_3	P0.3 MOSI	General-Purpose I/O. Master Output, Slave Input for SPI.
		GPIO_4	P0.4 ECLK P0.5 ¹ P0.6 ¹
	GPIO_5	P1.0 IRQ1 RxD	General-Purpose I/O. External Interrupt Request 1. Pin for UART.
		GPIO_6	P1.1 TxD
Port2	GPIO_7	P2.0 IRQ4 LIN Output Pin	General-Purpose I/O. External Interrupt Request 4. Used to read directly from LIN pin for conformance testing.
		GPIO_8	P2.1 IRQ5 LIN High Voltage Input Pin
	GPIO_11 ²	P2.4 ² LINRX	General-Purpose I/O. LIN Input Signal.
	GPIO_12 ²	P2.5 ² LINTX	General-Purpose I/O. LIN Output Signal.
	GPIO_13 ¹	P2.6 ¹	Reserved.

¹ These signals are internal signals only and do not appear on an external pin. These pins are used along with HVCON as the 2-wire interface to the high voltage interface circuits.

² These pins/signals are internal signals only and do not appear on external pins. Both signals are used to provide external pin diagnostic write (GPIO_12) and readback (GPIO_11) capability.

GPIO Port0 Control Register**Name:** GP0CON**Address:** 0xFFFF0D00**Default Value:** 0x11100000**Access:** Read/write**Function:** This 32-bit MMR selects the pin function for each Port0 pin.**Table 59. GP0CON MMR Bit Designations**

Bit	Description
31 to 29	Reserved. These bits are reserved and should be written as 0 by user code.
28	Reserved. This bit is reserved and should be written as 1 by user code.
27 to 25	Reserved. These bits are reserved and should be written as 0 by user code.
24	Internal P0.6 Enable Bit. This bit must be set to 1 by user software to enable the high voltage serial interface before using the HVCON and HVDAT registered high voltage interface.
23 to 21	Reserved. These bits are reserved and should be written as 0 by user code.
20	Internal P0.5 Enable Bit. This bit must be set to 1 by user software to enable the high voltage serial interface before using the HVCON and HVDAT registered high voltage interface.
19 to 17	Reserved. These bits are reserved and should be written as 0 by user code.
16	GPIO_4 Function Select Bit. Cleared to 0 by user code to configure the GPIO_4 pin as a general-purpose I/O (GPIO) pin. Set to 1 by user code to configure the GPIO_4 pin as ECLK, enabling a 2.56 MHz clock output on this pin.
15 to 13	Reserved. These bits are reserved and should be written as 0 by user code.
12	GPIO_3 Function Select Bit. Cleared to 0 by user code to configure the GPIO_3 pin as a general-purpose I/O (GPIO) pin. Set to 1 by user code to configure the GPIO_2 pin as MOSI (master output, slave input) data for the SPI port.
11 to 9	Reserved. These bits are reserved and should be written as 0 by user code.
8	GPIO_2 Function Select Bit. Cleared to 0 by user code to configure the GPIO_2 pin as a general-purpose I/O (GPIO) pin. Set to 1 by user code to configure the GPIO_3 pin as MISO (master input, slave output) data for the SPI port.
7 to 5	Reserved. These bits are reserved and should be written as 0 by user code.
4	GPIO_1 Function Select Bit. Cleared to 0 by user code to configure the GPIO_1 pin as a general-purpose I/O (GPIO) pin. Set to 1 by user code to configure the GPIO_1 pin as SCLK, serial clock I/O for the SPI port.
3 to 1	Reserved. These bits are reserved and should be written as 0 by user code.
0	GPIO_0 Function Select Bit. Cleared to 0 by user code to configure the GPIO_0 pin as a general-purpose I/O (GPIO) pin. Set to 1 by user code to configure the GPIO_0 pin as an SS (slave select) I/O for the SPI port.

ADuC7032-8L

GPIO Port1 Control Register

Name: GP1CON

Address: 0xFFFF0D04

Default Value: 0x10000000

Access: Read/write

Function: This 32-bit MMR selects the pin function for each Port1 pin.

Table 60. GP1CON MMR Bit Designations

Bit	Description
31 to 5	Reserved. These bits are reserved and should be written as 0 by user code.
4	GPIO_6 Function Select Bit. Cleared to 0 by user code to configure the GPIO_6 pin as a general-purpose I/O (GPIO) pin. Set to 1 by user code to configure the GPIO_6 pin as TxD, transmit data for UART serial port.
3 to 1	Reserved. These bits are reserved and should be written as 0 by user code.
0	GPIO_5 Function Select Bit. Cleared to 0 by user code to configure the GPIO_5 pin as a general-purpose I/O (GPIO) pin. Set to 1 by user code to configure the GPIO_5 pin as RxD, receive data for UART serial port.

GPIO Port2 Control Register

Name: GP2CON

Address: 0xFFFF0D08

Default Value: 0x01000000

Access: Read/write

Function: This 32-bit MMR selects the pin function for each Port2 pin.

Table 61. GP2CON MMR Bit Designations

Bit	Description
31 to 21	Reserved. These bits are reserved and should be written as 0 by user code.
20	GPIO_12 Function Select Bit. Cleared to 0 by user code to route the LIN transmit data to an internal general-purpose I/O (GPIO_12) pad that can then be written via the GP2DAT MMR. Set to 1 by user code to route the UART TxD (transmit data) to the LIN data pin. This configuration is used in LIN mode.
19 to 17	Reserved. These bits are reserved and should be written as 0 by user code.
16	GPIO_11 Function Select Bit. Cleared to 0 by user code to internally disable the LIN input data path. In this configuration, GPIO_11 is used to support diagnostic readback on all external high voltage I/O pins (see HVCFG1[2:0]). Set to 1 by user code to route input data from the LIN interface to both the LIN hardware timing/synchronization logic and to the UART RxD (receive data). This mode must be configured by user code when using LIN.
15 to 5	Reserved. These bits are reserved and should be written as 0 by user code.
4	GPIO_8 Function Select Bit. Cleared to 0 by user code to internally disable the LIN input data path. In this configuration, GPIO_11 is used to support diagnostic readback on all external high voltage I/O pins (see HVCFG1[2:0]). Set to 1 by user code to route input data from the LIN interface to both the LIN hardware timing/synchronization logic and the UART RxD (receive data). This mode must be configured by user code when using LIN.
3 to 1	Reserved. These bits are reserved and should be written as 0 by user code.
0	GPIO_7 Function Select Bit. Cleared to 0 by user code to configure the GPIO_7 pin as a general-purpose I/O (GPIO) pin. Set to 1 by user code to route data driven into the GPIO_7 pin through the on-chip LIN transceiver to be output at the LIN pin. This mode can be used to drive the LIN transceiver interface as a standalone component without any interaction from MCU or UART.

GPIO Port0 Data Register**Name:** GP0DAT**Address:** 0xFFFFF0D20**Default Value:** 0x000000XX**Access:** Read/write

Function: This 32-bit MMR configures the direction of the GPIO pins assigned to Port0 (see Table 58). This register also sets the output value for GPIO pins configured as outputs and reads the status of GPIO pins configured as inputs.

Table 62. GP0DAT MMR Bit Designations

Bit	Description
31 to 29	Reserved. These bits are reserved and should be written as 0 by user code.
28	Port0.4 Direction Select Bit. Cleared to 0 by user code to configure the GPIO pin assigned to P0.4 as an input. Set to 1 by user code to configure the GPIO pin assigned to P0.4 as an output.
27	Port0.3 Direction Select Bit. Cleared to 0 by user code to configure the GPIO pin assigned to P0.3 as an input. Set to 1 by user code to configure the GPIO pin assigned to P0.3 as an output.
26	Port0.2 Direction Select Bit. Cleared to 0 by user code to configure the GPIO pin assigned to P0.2 as an input. Set to 1 by user code to configure the GPIO pin assigned to P0.2 as an output.
25	Port0.1 Direction Select Bit. Cleared to 0 by user code to configure the GPIO pin assigned to P0.1 as an input. Set to 1 by user code to configure the GPIO pin assigned to P0.1 as an output.
24	Port0.0 Direction Select Bit. Cleared to 0 by user code to configure the GPIO pin assigned to P0.0 as an input. Set to 1 by user code to configure the GPIO pin assigned to P0.0 as an output.
23 to 21	Reserved. These bits are reserved and should be written as 0 by user code.
20	Port0.4 Data Output. The value written to this bit appears directly on the GPIO pin assigned to P0.4.
19	Port0.3 Data Output. The value written to this bit appears directly on the GPIO pin assigned to P0.3.
18	Port0.2 Data Output. The value written to this bit appears directly on the GPIO pin assigned to P0.2.
17	Port0.1 Data Output. The value written to this bit appears directly on the GPIO pin assigned to P0.1.
16	Port0.0 Data Output. The value written to this bit appears directly on the GPIO pin assigned to P0.0.
15 to 5	Reserved. These bits are reserved and should be written as 0 by user code.
4	Port0.4 Data Input. This bit is a read-only bit that reflects the current status of the GPIO pin assigned to P0.4. User code should write 0 to this bit.
3	Port0.3 Data Input. This bit is a read-only bit that reflects the current status of the GPIO pin assigned to P0.3. User code should write 0 to this bit.
2	Port0.2 Data Input. This bit is a read-only bit that reflects the current status of the GPIO pin assigned to P0.2. User code should write 0 to this bit.
1	Port0.1 Data Input. This bit is a read-only bit that reflects the current status of the GPIO pin assigned to P0.1. User code should write 0 to this bit.
0	Port0.0 Data Input. This bit is a read-only bit that reflects the current status of the GPIO pin assigned to P0.0. User code should write 0 to this bit.

ADuC7032-8L

GPIO Port1 Data Register

Name: GP1DAT

Address: 0xFFFF0D30

Default Value: 0x000000XX

Access: Read/write

Function: This 32-bit MMR configures the direction of the GPIO pins assigned to Port1 (see Table 58). This register also sets the output value for GPIO pins configured as outputs and reads the status of GPIO pins configured as inputs.

Table 63. GP1DAT MMR Bit Designations

Bit	Description
31 to 26	Reserved. These bits are reserved and should be written as 0 by user code.
25	Port1.1 Direction Select Bit. Cleared to 0 by user code to configure the GPIO pin assigned to P1.1 as an input. Set to 1 by user code to configure the GPIO pin assigned to P1.1 as an output.
24	Port1.0 Direction Select Bit. Cleared to 0 by user code to configure the GPIO pin assigned to P1.0 as an input. Set to 1 by user code to configure the GPIO pin assigned to P1.0 as an output.
23 to 18	Reserved. These bits are reserved and should be written as 0 by user code.
17	Port1.1 Data Output. The value written to this bit appears directly on the GPIO pin assigned to P1.1.
16	Port1.0 Data Output. The value written to this bit appears directly on the GPIO pin assigned to P1.0.
15 to 2	Reserved. These bits are reserved and should be written as 0 by user code.
1	Port1.1 Data Input. This bit is a read-only bit that reflects the current status of the GPIO pin assigned to P1.1. User code should write 0 to this bit.
0	Port1.0 Data Input. This bit is a read-only bit that reflects the current status of the GPIO pin assigned to P1.0. User code should write 0 to this bit.

GPIO Port2 Data Register

Name: GP2DAT

Address: 0xFFFF0D40

Default Value: 0x000000XX

Access: Read/write

Function: This 32-bit MMR configures the direction of the GPIO pins assigned to Port2 (see Table 58). This register also sets the output value for GPIO pins configured as outputs and reads the status of GPIO pins configured as inputs.

Table 64. GP2DAT MMR Bit Designations

Bit	Description
31	Reserved. This bit is reserved and should be written as 0 by user code.
30	Port2.6 Direction Select Bit. Cleared to 0 by user code to configure the GPIO pin assigned to P2.6 as an input. Set to 1 by user code to configure the GPIO pin assigned to P2.6 as an output.
29	Port2.5 Direction Select Bit. Cleared to 0 by user code to configure the GPIO pin assigned to P2.5 as an input. Set to 1 by user code to configure the GPIO pin assigned to P2.5 as an output. This configuration is used to support diagnostic write capability to the high voltage I/O pins.
28	Port2.4 Direction Select Bit. Cleared to 0 by user code to configure the GPIO pin assigned to P2.4 as an input. This configuration is used to support diagnostic readback capability from the high voltage I/O pins (see HVCFG1[2:0]). Set to 1 by user code to configure the GPIO pin assigned to P2.4 as an output.
27 to 26	Reserved. These bits are reserved and should be written as 0 by user code.
25	Port2.1 Direction Select Bit. Cleared to 0 by user code to configure the GPIO pin assigned to P2.1 as an input. Set to 1 by user code to configure the GPIO pin assigned to P2.1 as an output.
24	Port2.0 Direction Select Bit. Cleared to 0 by user code to configure the GPIO pin assigned to P2.0 as an input. Set to 1 by user code to configure the GPIO pin assigned to P2.0 as an output.
23	Reserved. This bit is reserved and should be written as 0 by user code.

Bit	Description
22	Port2.6 Data Output. The value written to this bit appears directly on the GPIO pin assigned to P2.6
21	Port2.5 Data Output. The value written to this bit appears directly on the GPIO pin assigned to P2.5.
20 to 18	Reserved. These bits are reserved and should be written as 0 by user code.
17	Port2.1 Data Output. The value written to this bit appears directly on the GPIO pin assigned to P2.1.
16	Port2.0 Data Output. The value written to this bit appears directly on the GPIO pin assigned to P2.0.
15 to 7	Reserved. These bits are reserved and should be written as 0 by user code.
6	Port2.6 Data Input. This bit is a read-only bit that reflects the current status of the GPIO pin assigned to P2.6. User code should write 0 to this bit.
5	Port2.5 Data Input. This bit is a read-only bit that reflects the current status of the GPIO pin assigned to P2.5. User code should write 0 to this bit.
4	Port2.4 Data Input. This bit is a read-only bit that reflects the current status of the GPIO pin assigned to P2.4. User code should write 0 to this bit.
3 to 2	Reserved. These bits are reserved and should be written as 0 by user code.
1	Port2.1 Data Input. This bit is a read-only bit that reflects the current status of the GPIO pin assigned to P2.1. User code should write 0 to this bit.
0	Port2.0 Data Input. This bit is a read-only bit that reflects the current status of the GPIO pin assigned to P2.0. User code should write 0 to this bit.

GPIO Port0 Set Register

Name: GP0SET

Address: 0xFFFFF0D24

Access: Write only

Function: This 32-bit MMR allows user code to individually bit address external GPIO pins to set them high only. User code can do this via the GP0SET MMR without needing to modify or maintain the status of any other GPIO pins, as user code needs to do when using GP0DAT.

Table 65. GP0SET MMR Bit Designations

Bit	Description
31 to 21	Reserved. These bits are reserved and should be written as 0 by user code.
20	Port0.4 Set Bit. Set to 1 by user code to set the external GPIO_4 pin high. If user software clears this bit to 0, it has no effect on the external GPIO_4 pin.
19	Port0.3 Set Bit. Set to 1 by user code to set the external GPIO_3 pin high. If user software clears this bit to 0, it has no effect on the external GPIO_3 pin.
18	Port0.2 Set Bit. Set to 1 by user code to set the external GPIO_2 pin high. If user software clears this bit to 0, it has no effect on the external GPIO_2 pin.
17	Port0.1 Set Bit. Set to 1 by user code to set the external GPIO_1 pin high. If user software clears this bit to 0, it has no effect on the external GPIO_1 pin.
16	Port0.0 Set Bit. Set to 1 by user code to set the external GPIO_0 pin high. If user software clears this bit to 0, it has no effect on the external GPIO_0 pin.
15 to 0	Reserved. These bits are reserved and should be written as 0 by user code.

ADuC7032-8L

GPIO Port1 Set Register

Name: GP1SET

Address: 0xFFFF0D34

Access: Write only

Function: This 32-bit MMR allows user code to individually bit address external GPIO pins to set them high only. User code can do this via the GP1SET MMR without needing to modify or maintain the status of any other GPIO pins, as user code needs to do when using GP1DAT.

Table 66. GP1SET MMR Bit Designations

Bit	Description
31 to 18	Reserved. These bits are reserved and should be written as 0 by user code.
17	Port1.1 Set Bit. Set to 1 by user code to set the external GPIO_6 pin high. If user software clears this bit to 0, it has no effect on the external GPIO_6 pin.
16	Port1.0 Set Bit. Set to 1 by user code to set the external GPIO_5 pin high. If user software clears this bit to 0, it has no effect on the external GPIO_5 pin.
15 to 0	Reserved. These bits are reserved and should be written as 0 by user code.

GPIO Port2 Set Register

Name: GP2SET

Address: 0xFFFF0D44

Access: Write only

Function: This 32-bit MMR allows user code to individually bit address external GPIO pins to set them high only. User code can do this via the GP2SET MMR without needing to modify or maintain the status of any other GPIO pins, as user code needs to do when using GP2DAT.

Table 67. GP2SET MMR Bit Designations

Bit	Description
31 to 23	Reserved. These bits are reserved and should be written as 0 by user code.
22	Port2.6 Set Bit. Set to 1 by user code to set the external GPIO_13 pin high. If user software clears this bit to 0, it has no effect on the external GPIO_13 pin.
21	Port2.5 Set Bit. Set to 1 by user code to set the external GPIO_12 pin high. If user software clears this bit to 0, it has no effect on the external GPIO_12 pin.
20 to 18	Reserved. These bits are reserved and should be written as 0 by user code.
17	Port2.1 Set Bit. Set to 1 by user code to set the external GPIO_8 pin high. If user software clears this bit to 0, it has no effect on the external GPIO_8 pin.
16	Port2.0 Set Bit. Set to 1 by user code to set the external GPIO_7 pin high. If user software clears this bit to 0, it has no effect on the external GPIO_7 pin.
15 to 0	Reserved. These bits are reserved and should be written as 0 by user code.

GPIO Port0 Clear Register**Name:** GP0CLR**Address:** 0xFFFFF0D28**Access:** Write only

Function: This 32-bit MMR allows user code to individually bit address external GPIO pins to clear them low only. User code can do this via the GP0CLR MMR without needing to modify or maintain the status of any other GPIO pins, as user code needs to do when using GP0DAT.

Table 68. GP0CLR MMR Bit Designations

Bit	Description
31 to 21	Reserved. These bits are reserved and should be written as 0 by user code.
20	Port0.4 Clear Bit. Set to 1 by user code to clear the external GPIO_4 pin low. If user software clears this bit to 0, it has no effect on the external GPIO_4 pin.
19	Port0.3 Clear Bit. Set to 1 by user code to clear the external GPIO_3 pin low. If user software clears this bit to 0, it has no effect on the external GPIO_3 pin.
18	Port0.2 Clear Bit. Set to 1 by user code to clear the external GPIO_2 pin low. If user software clears this bit to 0, it has no effect on the external GPIO_2 pin.
17	Port0.1 Clear Bit. Set to 1 by user code to clear the external GPIO_1 pin low. If user software clears this bit to 0, it has no effect on the external GPIO_1 pin.
16	Port0.0 Clear Bit. Set to 1 by user code to clear the external GPIO_0 pin low. If user software clears this bit to 0, it has no effect on the external GPIO_0 pin.
15 to 0	Reserved. These bits are reserved and should be written as 0 by user code.

GPIO Port1 Clear Register**Name:** GP1CLR**Address:** 0xFFFFF0D38**Access:** Write only

Function: This 32-bit MMR allows user code to individually bit address external GPIO pins to clear them low only. User code can do this via the GP1CLR MMR without needing to modify or maintain the status of any other GPIO pins, as user code needs to do when using GP1DAT.

Table 69. GP1CLR MMR Bit Designations

Bit	Description
31 to 18	Reserved. These bits are reserved and should be written as 0 by user code.
17	Port1.1 Clear Bit. Set to 1 by user code to clear the external GPIO_6 pin low. If user software clears this bit to 0, it has no effect on the external GPIO_6 pin.
16	Port1.0 Clear Bit. Set to 1 by user code to clear the external GPIO_5 pin low. If user software clears this bit to 0, it has no effect on the external GPIO_5 pin.
15 to 0	Reserved. These bits are reserved and should be written as 0 by user code.

ADuC7032-8L

GPIO Port2 Clear Register

Name: GP2CLR

Address: 0xFFFF0D48

Access: Write only

Function: This 32-bit MMR allows user code to individually bit address external GPIO pins to clear them low only. User code can do this via the GP2CLR MMR without needing to modify or maintain the status of any other GPIO pins, as user code needs to do when using GP2DAT.

Table 70. GP2CLR MMR Bit Designations

Bit	Description
31 to 23	Reserved. These bits are reserved and should be written as 0 by user code.
22	Port2.6 Clear Bit. Set to 1 by user code to clear the external GPIO_13 pin low. If user software clears this bit to 0, it has no effect on the external GPIO_8 pin.
21	Port2.5 Clear Bit. Set to 1 by user code to clear the external GPIO_12 pin low. If user software clears this bit to 0, it has no effect on the external GPIO_7 pin.
20 to 18	Reserved. These bits are reserved and should be written as 0 by user code.
17	Port2.1 Clear Bit. Set to 1 by user code to clear the external GPIO_8 pin low. If user software clears this bit to 0, it has no effect on the external GPIO_8 pin.
16	Port2.0 Clear Bit. Set to 1 by user code to clear the external GPIO_7 pin low. If user software clears this bit to 0, it has no effect on the external GPIO_7 pin.
15 to 0	Reserved. These bits are reserved and should be written as 0 by user code.

HIGH VOLTAGE PERIPHERAL CONTROL INTERFACE

The ADuC7032-8L integrates a number of high voltage circuit functions that are controlled and monitored via a registered interface consisting of two MMRs, namely, HVCON and HVDAT. The HVCON register acts as a command byte interpreter, allowing the microcontroller to indirectly read or write 8-bit data (the value in HVDAT) from or to one of four high voltage status or configuration registers. It should be noted that these high voltage registers are not MMRs but are so-called indirect registers that can only be accessed (as the name suggests) indirectly, via the HVCON and HVDAT MMRs.

The physical interface between the HVCON register and the indirect high voltage registers is a 2-wire (data and clock) serial interface based on a 2.56 MHz serial clock. Therefore, there is a finite, 10 μs (maximum) latency between the MCU core writing a command into HVCON and that command or data reaching the indirect high voltage registers. There is also a finite 10 μs latency between the MCU core writing a command into HVCON

and indirect register data being read back into the HVDAT register.

A busy bit (Bit 0 of the HVCON, when read by the MCU) can be polled by the MCU to confirm when a read/write command has completed.

Figure 37 describes the top-level architecture of the high voltage interface and related circuits. The following high voltage circuit functions are controlled and monitored via this interface:

- Precision oscillator
- Wake-up pin functionality
- Power supply monitor
- Low voltage flag
- LIN operating modes
- High voltage diagnostics
- High voltage attenuator/buffer circuit
- High voltage temperature

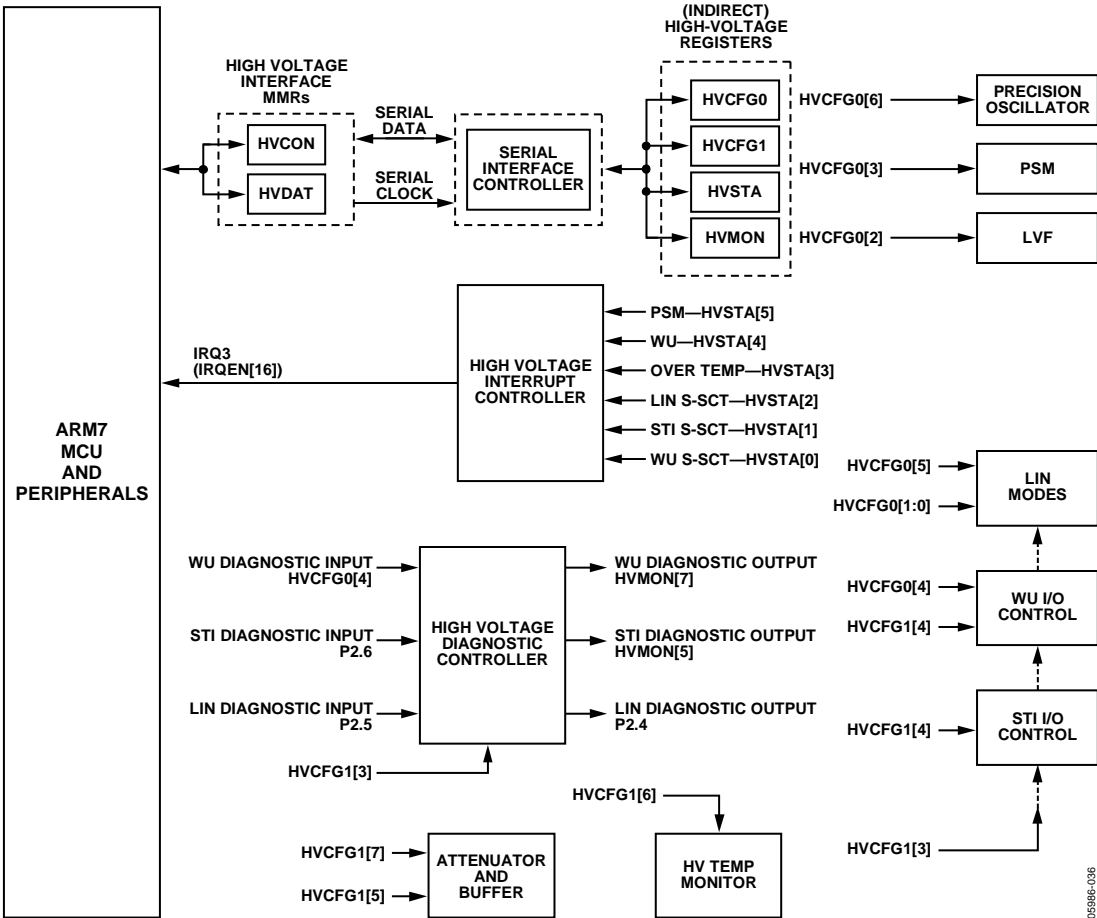

Figure 37. High Voltage Interface, Top Level Block Diagram

ADuC7032-8L

High Voltage Interface Control Register

Name: HVCON

Address: 0xFFFF0804

Default Value: 0x00

Access: Read/write

Function: This 8-bit register acts as a command byte interpreter for the high voltage control interface. Bytes written to this register are interpreted as read or write commands to a set of four indirect registers related to the high voltage circuits. The HVDAT register is used to store data to be written to or read back from the indirect registers.

Table 71. HVCON MMR Write Bit Designations

Bit	Description
7 to 0	Command Byte 0x00 = read back High Voltage Register HVCFG0 into HVDAT. Command Byte 0x01 = read back High Voltage Register HVCFG1 into HVDAT. Command Byte 0x02 = read back High Voltage Status Register HVSTA into HVDAT. Command Byte 0x03 = read back High Voltage Status Register HVMON into HVDAT. Command Byte 0x08 = write the value in HVDAT to the High Voltage Register HVCFG0. Command Byte 0x09 = write the value in HVDAT to the High Voltage Register HVCFG1. All other command bytes are reserved and should not be written by user code.

Table 72. HVCON MMR Read Bit Designations

Bit	Description
7 to 3	Reserved.
2	Transmit command to high voltage die status. 1 = command completed successfully. 0 = command failed.
1	Read command from high voltage die status. 1 = command completed successfully. 0 = command failed.
0	Busy Bit (Read Only). When user code reads this register, Bit 0 should be interpreted as the busy signal for the high voltage interface. This bit can be used to determine if a read request has completed. High voltage (read/write) commands, as described previously, should not be written to HVCON unless busy = 0. 1 = high voltage interface is busy and has not completed the previous command written to HVCON; Bit 1 and Bit 2 are not valid. 0 = high voltage interface is not busy and has completed the command written to HVCON; Bit 1 and Bit 2 are valid.

High Voltage Data Register

Name: HVDAT

Address: 0xFFFF080C

Default Value: Modified by kernel

Access: Read/write

Function: This 12-bit register is used to hold data to be written indirectly to and read indirectly from the high voltage interface registers.

Table 73. HVDAT MMR Bit Designations

Bit	Description
11 to 8	Command Associated with High Voltage Data, HVDAT[7:0]. These bits are read only and should be written as 0s. 0x00 = read back High Voltage Register HVCFG0 into HVDAT. 0x01 = read back High Voltage Register HVCFG1 into HVDAT. 0x02 = read back High Voltage Status Register HVSTA into HVDAT. 0x03 = read back High Voltage Status Register HVMON into HVDAT. 0x08 = write the value in HVDAT to the high voltage register HVCFG0. 0x09 = write the value in HVDAT to the high voltage register HVCFG1.
7 to 0	High Voltage Data to Read/Write.

High Voltage Configuration 0 Register**Name:** HVCFG0**Address:** Indirectly addressed via the HVCON high voltage interface**Default Value:** 0x00**Access:** Read/write

Function: This 8-bit register controls the function of high voltage circuits on the ADuC7032-8L. This register is not an MMR and does not appear in the MMR memory map. It is accessed via the HVCON registered interface. Data to be written to this register is loaded via the HVDAT MMR and data is read back from this register via the HVDAT MMR.

Table 74. HVCFG0 Bit Designations

Bit	Description
7	WU Thermal Shutdown Disable. 1 = disable the automatic shutdown of the WU driver when a thermal event occurs. 0 = enable the automatic shutdown of the WU driver when a thermal event occurs.
6	Precision Oscillator Enable Bit. 1 = enable the precision 131 kHz oscillator. The oscillator start-up time is typically 70 μ s (including high voltage interface latency of 10 μ s). 0 = power-down the precision 131 kHz oscillator.
5	Reserved. This bit is reserved and should be written as 0 by user code.
4	WU Assert Bit. 1 = assert the external WU pin high. 0 = pull the external WU pin low via an internal 10 k Ω pull-down resistor.
3	PSM Enable Bit. 0 = disable the power supply (voltage at the VDD pin) monitor. 1 = enable the power supply (voltage at the VDD pin) monitor. When IRQ3 (IRQEN[16]) is enabled, the PSM generates an interrupt if the voltage at the VDD pin drops below 6.0 V.
2	Low Voltage Flag Enable Bit. 0 = disable the low voltage flag function. 1 = enable the low voltage flag function. The low voltage flag can be interrogated via HVMON[3] after power-up to determine if the REG_DVDD voltage previously dropped below 2.1 V.
1 to 0	LIN Operating Mode. These bits enable/disable the LIN driver. 00 = LIN disabled. 01 = reserved (not LIN 2.0 compliant). 10 = LIN enabled. 11 = reserved.

ADuC7032-8L

High Voltage Configuration1 Register

Name: HVCFG1

Address: Indirectly addressed via the HVCON high voltage interface

Default Value: 0x00

Access: Read/write

Function: This 8-bit register controls the function of high voltage circuits on the ADuC7032-8L. This register is not an MMR and does not appear in the MMR memory map. It is accessed via the HVCON registered interface. Data to be written to this register is loaded via HVDAT, and data is read back from this register via HVDAT.

Table 75. HVCFG1 Bit Designations

Bit	Description
7	Attenuator Enable Bit. 0 = disable the internal voltage attenuator and attenuator buffer. 1 = enable the internal voltage attenuator and attenuator buffer.
6	High Voltage Temperature Monitor. The high voltage temperature monitor is an uncalibrated temperature monitor located on-chip close to the high voltage circuits. This monitor is completely separate from the on-chip, precision temperature sensor (controlled via ADC2CON[7:6]) and allows user code to monitor die temperature change close to the hottest part of the ADuC7032-8L die. The monitor generates a typical output voltage of 600 mV at 25°C and typically has a negative temperature coefficient of $-2.1 \text{ mV}/^\circ\text{C}$. 1 = enable the on-chip, high voltage temperature monitor. Once enabled, this voltage output temperature monitor is routed directly to the temperature channel ADC. 0 = disable the on-chip, high voltage temperature monitor.
5	Voltage Channel Short Enable Bit. 1 = enable an internal short (at the attenuator, before ADC input buffer) on the voltage channel ADC and allow noise to be measured as a self-diagnostic test. 0 = disable an internal short on the voltage channel.
4	WU Readback Enable Bit. 0 = disable input capability on the external WU pin. 1 = enable input capability on the external WU pin. In this mode, a rising or falling edge transition on the WU pin generates a high voltage interrupt. Once this bit is set, the state of the WU pin can be monitored via the HVMON register (HVMON[7]).
3	High Voltage I/O Enable Bit. 1 = re-enable any high voltage I/O pins (LIN/WU) that have been disabled as a result of a short-circuit current event (event must last longer than 20 μs for the LIN pin and 400 μs for the WU pin). This bit must also be set to 1 to re-enable the WU pin, if disabled by a thermal event. It should be noted that this bit must be set to clear any pending interrupt generated by the short-circuit event (even if the event has passed), as well as re-enabling the high voltage I/O pins.
2	Enable/Disable Short-Circuit Protection (LIN). 1 = enable passive short-circuit protection on the LIN pin. In this mode, a short-circuit event on the LIN pin generates a high voltage interrupt, IRQ3 (if enabled in IRQEN[16]), and asserts the appropriate status bit in HVSTA but does not disable the short-circuiting pin. 0 = enable active short-circuit protection on the LIN pin. In this mode, a short-circuit event causes the LIN pin to generate a high voltage interrupt (IRQ3), assert IRQSTA[16], and automatically disable the short-circuiting pin. Once disabled, the I/O pin can be re-enabled only by writing to HVCFG1[3].
1	WU Pin Timeout (Monoflop) Counter Enable/Disable. 1 = disable the WU I/O timeout counter. 0 = enable a timeout counter that automatically deasserts the WU pin 1.3 seconds after user code has asserted the WU pin via HVCFG0[4].
0	WU Open Circuit Diagnostic Enable. 1 = enable an internal WU I/O diagnostic pull-up resistor to the VDD pin, allowing detection of an open-circuit condition on the WU pin. 0 = disable an internal WU I/O diagnostic pull-up resistor.

High Voltage Interrupt Status Register**Name:** HVSTA**Address:** Indirectly addressed via the HVCON high voltage interface**Default Value:** 0x00**Access:** Read only. This register should be read only on a high voltage interrupt.**Function:** This 8-bit, read-only register reflects a change of state of all the corresponding bits in the HVMON register. This register is not an MMR and does not appear in the MMR memory map. It is accessed via the HVCON registered interface, and data is read back from this register via HVDAT. It should be noted that in response to a high voltage interrupt event, the high voltage interrupt controller simultaneously and automatically loads the current value of the high voltage status register (HVSTA) into the HVDAT register.**Table 76. HVSTA Bit Designations**

Bit	Description
7 to 6	Reserved. These bits should not be used and are reserved for future use.
5	PSM Status Bit. (Valid only if enabled via HVCFG0[3].) This bit is 0 if the voltage at the VDD pin remains above 6.0 V. This bit is 1 if the voltage at the VDD pin drops below 6.0 V. Note that this bit is not latched, and the IRQ needs to be enabled to detect it.
4	WU Request Status Bit. (Valid only if enabled via HVCFG1[4].) Once enabled via HVCFG1[4], this bit is set to 1 to indicate that a rising or falling edge transition on the WU pin has generated a high voltage interrupt.
3	Overtemperature. Always enabled. This bit is 0 if a thermal shutdown event has not occurred. This bit is 1 if a thermal shutdown event has occurred.
2	LIN Short-Circuit Status Flag. This bit is 0 during normal LIN operation. This bit is 1 if a LIN short circuit is detected; in this condition, the LIN driver is automatically disabled.
1	Reserved. This bit is reserved and should be written as 0 by user code.
0	WU Short-Circuit Status Flag. This bit is 0 during normal WU operation. This bit is 1 if a WU short circuit is detected.

ADuC7032-8L

High Voltage Monitor Register

Name: HVMON

Address: Indirectly addressed via the HVCON high voltage interface

Default Value: 0x00

Access: Read only

Function: This 8-bit, read-only register reflects the current status of enabled high voltage related circuits and functions on the ADuC7032-8L. This register is not an MMR and does not appear in the MMR memory map. It is accessed via the HVCON registered interface, and data is read back from this register via HVDAT.

Table 77. HVMON Bit Designations

Bit	Description
7	WU Pin Diagnostic Readback. Once enabled via HVCFG1[4], this read-only bit reflects the state of the external WU (wake-up) pin.
6	Overtemperature. This bit is 0 if a thermal shutdown event has not occurred. This bit is 1 if a thermal shutdown event has occurred.
5	Reserved. This bit should not be used and is reserved for future use.
4	Buffer Enabled. This bit is 0 if the voltage channel ADC input buffer is disabled. This bit is 1 if the voltage channel ADC input buffer is enabled.
3	Low Voltage Flag Status Bit. (Valid only if enabled via HVCFG0[2].) This bit is 0 on power-up if REG_DVDD has dropped below 2.1 V. In this state, RAM contents can be deemed corrupt. This bit is 1 on power-up if REG_DVDD has not dropped below 2.1 V. In this state, RAM contents can be deemed valid. It is cleared only by re-enabling the low voltage flag in HVCFG0[2].
2	LIN Short-Circuit Status Flag. This bit is 0 if the LIN driver is operating normally. This bit is 1 if the LIN driver has experienced a short-circuit condition and is cleared automatically by writing to HVCFG1[3].
1	Reserved. This bit should not be used and is reserved for future use.
0	WU Short-Circuit Status Flag. This bit is 0 if the WU driver is operating normally. This bit is 1 if the WU driver has experienced a short-circuit condition.

WU (WAKE-UP) PIN

The WU (wake-up) pin is a high voltage GPIO controlled via HVCON and HVDAT.

WU Pin Circuit Description

The WU pin is configured by default as an output with an internal 10 kΩ pull-down resistor and high-side FET driver. The WU pin, in its default mode of operation, is specified to generate an active high system wake-up request by forcing the external system WU bus high. User code can assert the WU output by writing directly to HVCFG0[4].

It should be noted that the output responds only after the 10 μs latency through the (serial communication based) high voltage interface.

The internal FET is capable of sourcing significant current and, therefore, a substantial on-chip self-heating can occur if this driver is asserted for a long time period. For this reason, a monoflop (a 1.3-second timeout timer) has been included.

By default, the monoflop is enabled and disables the WU driver after 1.3 seconds. It is possible to disable the monoflop via HVCFG1[1]. If the WU monoflop is disabled, then the WU driver should be disabled after 1.3 seconds.

The WU pin also features a short-circuit detection feature. When the WU pin sources more than 200 mA for 400 μs, a high voltage interrupt is generated with HVMON[0] set.

By default, a thermal shutdown event disables the WU driver. The WU driver must be re-enabled manually after a thermal event via HVCFG1[3]. It is possible to disable the automatic shutdown during a thermal event via HVCFG0[7].

The WU pin can be configured in I/O mode by writing a 1 to HVCFG1[4]. In this mode, a rising or falling edge immediately generates a high voltage interrupt. HVMON[7] directly reflects the state of the external WU pin. This comparator has a trip level of 3 V typical.

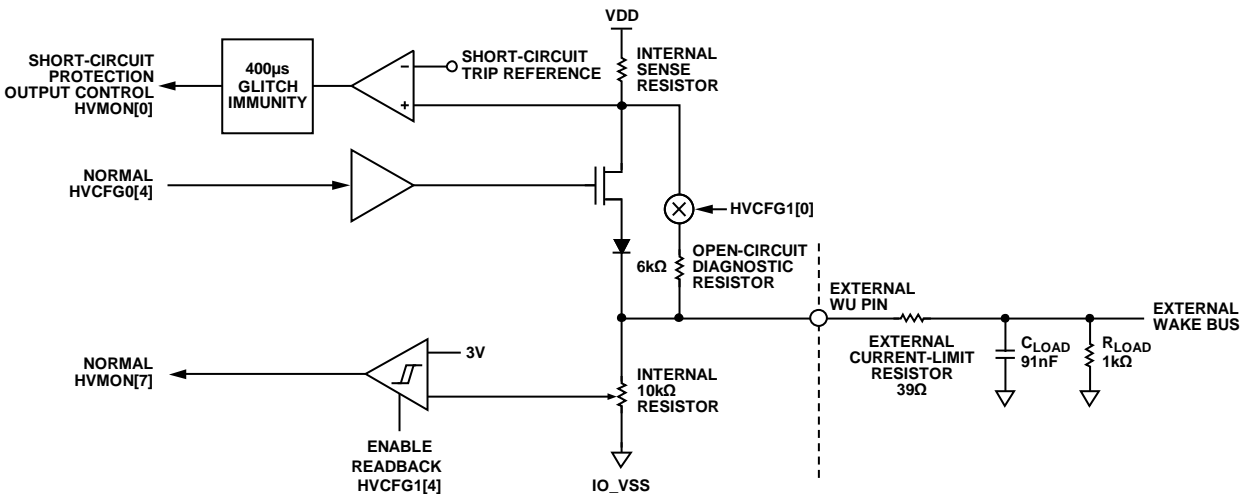

Figure 38. WU Circuit, Block Diagram

05886-0-46

HANDLING INTERRUPTS FROM THE HIGH VOLTAGE PERIPHERAL CONTROL INTERFACE

An interrupt controller is also integrated with the high voltage circuits. If enabled via IRQEN[16], one of five high voltage sources can assert the high voltage interrupt (IRQ3) signal and interrupt the MCU core.

While the MCU response to this interrupt event is, as normal, to vector to the IRQ or FIQ interrupt vector address, the high voltage interrupt controller simultaneously and automatically loads the current value of the high voltage status register (HVSTA) into the HVDAT register. During this time the busy bit, HVCON[0], is set to indicate the transfer is in progress and clears after 10 μ s to indicate the HVSTA contents are available in HVDAT.

The interrupt handler can, therefore, poll the busy bit in HVCON until it deasserts and then read the HVDAT register.

At this time, HVDAT holds the value of the HVSTA register. The status flags can then be interrogated to determine the exact source of the high voltage interrupt and take appropriate action.

LOW VOLTAGE FLAG (LVF)

The ADuC7032-8L features a low voltage flag (LVF) that, when enabled, allows the user to monitor REG_DVDD. When enabled via HVCFG0[2], the low voltage flag can be monitored through HVMON[3]. If REG_DVDD drops below 2.1 V, HVMON[3] is cleared. If REG_DVDD drops below 2.1 V, the RAM contents are corrupted. Once the low voltage flag is enabled, it is reset only by REG_DVDD dropping below 2.1 V or the disabling of the LVF functionality using HVCFG0[2].

HIGH VOLTAGE DIAGNOSTICS

It is possible to diagnose fault conditions on the WU and LIN bus, as detailed in Table 78.

Table 78. High Voltage Diagnostics

High Voltage Pin	Fault Condition	Method	Result
LIN	Short between LIN and VBAT	Drive LIN low	LIN short-circuit interrupt is generated after 20 μ s if more than 100 mA is drawn continuously.
	Short between LIN and GND	Drive LIN high	LIN readback low.
WU	Short between WU and VBAT	Drive WU low	Readback high.
	Short between WU and GND	Drive WU high	WU short-circuit interrupt is generated after 400 μ s if more than 200 mA is sourced.
	Open circuit	Enable OC diagnostic resistor with WU disabled	HVMON[7] is cleared if load is connected; HVMON[7] is set if WU is open-circuited.

UART SERIAL INTERFACE

The ADuC7032-8L features a 16,450-compatible UART. The UART is a full-duplex universal asynchronous receiver/transmitter that performs serial-to-parallel conversion on data characters received from a peripheral device or a modem, and parallel-to-serial conversion on data characters received from the ARM7TDMI. The UART features a fractional divider, which facilitates high accuracy baud rate generation, and a network addressable mode. The UART functionality is made available on GPIO_5 and GPIO_6 (RxD and TxD) of the ADuC7032-8L.

The serial communication adopts an asynchronous protocol that supports various word length, stop bits, and parity generation options selectable in the configuration register.

BAUD RATE GENERATION

The ADuC7032-8L features two methods of generating the UART baud rate.

- Normal 450 UART baud rate generation
- ADuC7032-8L fractional divider

These two methods are explained in detail in the Normal 450 UART Baud Rate Generation section and the ADuC7032-8L Fractional Divider section.

Normal 450 UART Baud Rate Generation

The baud rate is a divided version of the core clock using the value in COMDIV0 and COMDIV1 MMRs (16-bit value, DL).

$$\text{Baud Rate} = \frac{20.48 \text{ MHz}}{2^{CD} \times 16 \times 2 \times DL}$$

Table 79 lists common baud rate values.

Table 79. Baud Rate Using the Standard Baud Rate Generator

Baud Rate	CD	DL	Actual Baud Rate	% Error
9600	0	0x43	9552	0.50
19,200	0	0x21	19,394	1.01
115,200	0	0x6	106,667	7.41
9600	3	0x8	10,000	4.17
19,200	3	0x4	20,000	4.17
115,200	3	0x1	80,000	30.56

ADuC7032-8L Fractional Divider

The fractional divider combined with the normal baud rate generator allows the generation of accurate, high speed baud rates.

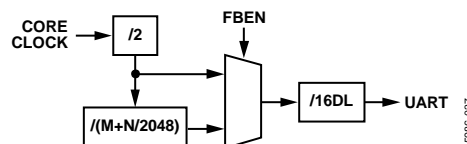

Figure 39. Fractional Divider Baud Rate Generation

Calculation of the baud rate using a fractional divider follows:

$$\text{Baud Rate} = \frac{20.48 \text{ MHz}}{2^{CD} \times 16 \times DL \times 2 \times \left(M + \frac{N}{2048}\right)}$$

$$M + \frac{N}{2048} = \frac{20.48 \text{ MHz}}{\text{Baud Rate} \times 2^{CD} \times 16 \times DL \times 2}$$

Table 80 shows some common baud rate values.

Table 80. Baud Rate Using the Fractional Baud Rate Generator

Baud Rate	CD	DL	M	N	Actual Baud Rate	% Error
9600	0	0x42	1	21	9598.55	0.015
19,200	0	0x21	1	21	19,197.09	0.015
115,200	0	0x5	1	228	115,177.51	0.0195

UART REGISTER DEFINITIONS

The UART interface consists of the following 10 registers:

- COMTX: 8-bit transmit register
- COMRX: 8-bit receive register
- COMDIV0: divisor latch (low byte)
- COMDIV1: divisor latch (high byte)
- COMCON0: line control register
- COMCON1: UART control register
- COMSTA0: line status register
- COMIEN0: interrupt enable register
- COMIID0: interrupt identification register
- COMDIV2: 16-bit fractional baud divide register

COMTX, COMRX, and COMDIV0 share the same address location. COMTX and COMRX can be accessed when Bit 7 in the COMCON0 register is cleared. COMDIV0 can be accessed when Bit 7 of COMCON0 is set.

ADuC7032-8L

UART TX Register

Name: COMTX
Address: 0xFFFF0700
Default Value: 0x00
Access: Write only
Function: This 8-bit register is written to when transmitting data using the UART.

UART RX Register

Name: COMRX
Address: 0xFFFF0700
Default Value: 0x00
Access: Read only
Function: This 8-bit register is read from to receive data transmitted using the UART.

UART Control Register 0

Name: COMCON0
Address: 0xFFFF070C
Default Value: 0x00
Access: Read/write
Function: This 8-bit register controls the operation of the UART in conjunction with COMCON1.

Table 81. COMCON0 MMR Bit Designations

Bit	Name	Description
7	DLAB	Divisor Latch Access. Set by user to enable access to COMDIV0 and COMDIV1 registers. Cleared by user to disable access to COMDIV0 and COMDIV1 and enable access to COMRX, COMTX, and COMIEN0.
6	BRK	Set Break. Set by user to force TxD to 0. Cleared to operate in normal mode.
5	SP	Stick Parity. Set by user to force parity to defined values. 1 if EPS = 1 and PEN = 1. 0 if EPS = 0 and PEN = 1.
4	EPS	Even Parity Select Bit. Set for even parity. Cleared for odd parity.
3	PEN	Parity Enable Bit. Set by user to transmit and check the parity bit. Cleared by user for no parity transmission or checking.
2	STOP	Stop Bit. Set by user to transmit 1.5 stops bit if the word length is five bits or two stop bits if the word length is six, seven, or eight bits. The receiver checks the first stop bit only, regardless of the number of stop bits selected. Cleared by user to generate one STOP bit in the transmitted data.
1 to 0	WLS	Word Length Select. 00 = 5 bits. 01 = 6 bits. 10 = 7 bits. 11 = 8 bits.

UART Divisor Latch Register 0

Name: COMDIV0
Address: 0xFFFF0700
Default Value: 0x00
Access: Read/write
Function: This 8-bit register contains the least significant byte of the divisor latch that controls the baud rate at which the UART operates.

UART Divisor Latch Register 1

Name: COMDIV1
Address: 0xFFFF0704
Default Value: 0x00
Access: Read/write
Function: This 8-bit register contains the most significant byte of the divisor latch that controls the baud rate at which the UART operates.

UART Control Register 1**Name:** COMCON1**Address:** 0xFFFF0710**Default Value:** 0x00**Access:** Read/write**Function:** This 8-bit register controls the operation of the UART in conjunction with COMCON0.**Table 82. COMCON1 MMR Bit Designations**

Bit	Name	Description
7 to 6		UART Input Multiplexer. 00 = RxD driven by LIN input; required for LIN communications via LIN pin. 01 = reserved. 10 = RxD driven by GPIO_5; required for serial communications via GPIO_5 pin (RxD). 11 = reserved.
5		Not Used. 0 by default.
4	LOOPBACK	Loop Back. Set by user to enable loopback mode. In loopback mode, the TxD is forced high.
3 to 0		Not Used. 0 by default.

UART Status Register 0**Name:** COMSTA0**Address:** 0xFFFF0714**Default Value:** 0x60**Access:** Read only**Function:** This 8-bit read-only register reflects the current status on the UART.**Table 83. COMSTA0 MMR Bit Designations**

Bit	Name	Description
7		Reserved.
6	TEMT	COMTX and Shift Register Empty Status Bit. Set automatically if COMTX and the shift register are empty. This bit indicates that the data has been transmitted; that is, it is no longer present in the shift register. Cleared automatically when writing to COMTX.
5	THRE	COMTX Empty Status Bit. Set automatically if COMTX is empty. COMTX can be written as soon as this bit is set. The previous data may not have been transmitted yet and may still be present in the shift register. Cleared automatically when writing to COMTX.
4	BI	Break Indicator. Set when SIN is held low for more than the maximum word length. Cleared automatically.
3	FE	Framing Error. Set when the stop bit is invalid. Cleared automatically.
2	PE	Parity Error. Set when a parity error occurs. Cleared automatically.
1	OE	Overrun Error. Set automatically if data is overwritten before having been read. Cleared automatically.
0	DR	Data Ready. Set automatically when COMRX is full. Cleared by reading COMRX.

ADuC7032-8L

UART Interrupt Enable Register 0

Name: COMIEN0

Address: 0xFFFF0704

Default Value: 0x00

Access: Read/write

Function: This 8-bit register enables and disables the individual UART interrupt sources.

Table 84. COMIEN0 MMR Bit Designations

Bit	Name	Description
7 to 3		Not Used. 0 by default.
2	ELSI	COMRX Status Interrupt Enable Bit. Set by user to enable generation of an interrupt if any of COMSTA0[3:1] are set. Cleared by user.
1	ETBEI	Enable Transmit Buffer Empty Interrupt. Set by user to enable interrupt when buffer is empty during a transmission, that is, when COMSTA[5] is set. Cleared by user.
0	ERBFI	Enable Receive Buffer Full Interrupt. Set by user to enable interrupt when buffer is full during a reception. Cleared by user.

UART Interrupt Identification Register 0

Name: COMIID0

Address: 0xFFFF0708

Default Value: 0x01

Access: Read only

Function: This 8-bit register reflects the source of the UART interrupt.

Table 85. COMIID0 MMR Bit Designations

Bits[2:1] Status Bits	Bit 0 NINT	Priority	Definition	Clearing Operation
00	1	N/A	No Interrupt.	N/A
11	0	1	Receive Line Status Interrupt.	Read COMSTA0.
10	0	2	Receive Buffer Full Interrupt.	Read COMRX.
01	0	3	Transmit Buffer Empty Interrupt.	Write data to COMTX or read COMIID0.
00	0	4	Modem Status Interrupt.	Read COMSTA1.

UART Fractional Divider Register

Name: COMDIV2

Address: 0xFFFF072C

Default Value: 0x0000

Access: Read/write

Function: This 16-bit register controls the operation of the ADuC7032-8L fractional divider.

Table 86. COMDIV2 MMR Bit Designations

Bit	Name	Description
15	FBEN	Fractional Baud Rate Generator Enable Bit. Set by user to enable the fractional baud rate generator. Cleared by user to generate baud rate using the standard 450 UART baud rate generator.
14 to 13		Reserved.
12 to 11	FBM[1:0]	M. If FBM = 0, M = 4.
10 to 0	FBN[10:0]	N.

SERIAL PERIPHERAL INTERFACE

The ADuC7032-8L features a complete hardware serial peripheral interface (SPI) on-chip. SPI is an industry-standard synchronous serial interface that allows eight bits of data to be synchronously transmitted and received simultaneously, that is, full duplex.

The SPI is operational only with core clock divider bits (POWCON[2:0] = 0 or 1).

The SPI port can be configured for master or slave operation and consists of four pins that are multiplexed with four GPIOs. The four SPI pins are MISO, MOSI, SCLK, and \overline{SS} . The pins to which these signals are connected are shown in Table 87.

Table 87. SPI Output Pins

Pin	Signal	Description
GPIO_0 (GPIO MODE 1)	\overline{SS}	Chip Select
GPIO_1 (GPIO MODE 1)	SCLK	Serial Clock
GPIO_2 (GPIO MODE 1)	MISO	Master In, Slave Out
GPIO_3 (GPIO MODE 1)	MOSI	Master Out, Slave In

MISO (MASTER IN, SLAVE OUT DATA I/O PIN)

The MISO (master in, slave out) pin is configured as an input line in master mode and an output line in slave mode. The MISO line on the master (data in) should be connected to the MISO line in the slave device (data out). The data is transferred as byte wide (8-bit) serial data, MSB first.

MOSI (MASTER OUT, SLAVE IN PIN)

The MOSI (master out, slave in) pin is configured as an output line in master mode and an input line in slave mode. The MOSI line on the master (data out) should be connected to the MOSI line in the slave device (data in). The data is transferred as byte wide (8-bit) serial data, MSB first.

SCLK (SERIAL CLOCK I/O PIN)

The master serial clock (SCLK) is used to synchronize the data being transmitted and received through the MOSI SCLK period. Therefore, a byte is transmitted/received after eight SCLK periods. The SCLK pin is configured as an output in master mode and as an input in slave mode.

In master mode, polarity and phase of the clock are controlled by the SPICON register, and the bit rate is defined in the SPIDIV register as follows:

$$f_{SERIALCLOCK} = \frac{20.48 \text{ MHz}}{2 \times (1 + SPIDIV)}$$

The maximum speed of the SPI clock is dependent on the clock divider bits and is summarized in Table 88.

Table 88. SPI Speed vs. Clock Divider Bits in Master Mode

CD Bits	0	1
SPIDIV	0x05	0x0B
Maximum SCLK	1.667 MHz	0.833 MHz

In slave mode, the SPICON register must be configured with the phase and polarity of the expected input clock. The slave accepts data from an external master up to 5.12 Mb at CD = 0. The formula to determine the maximum speed follows:

$$f_{SERIALCLOCK} = \frac{f_{HCLK}}{4}$$

In both master and slave modes, data is transmitted on one edge of the SCL signal and sampled on the other. Therefore, it is important that the polarity and phase be configured in the same way for the master and slave devices.

CHIP SELECT (\overline{SS}) INPUT PIN

In SPI slave mode, a transfer is initiated by the assertion of \overline{SS} , which is an active low input signal. The SPI port then transmits and receives 8-bit data until the transfer is concluded by deassertion of \overline{SS} . In slave mode, \overline{SS} is always an input.

SPI REGISTERS DEFINITIONS

The following MMR registers are used to control the SPI interface:

- SPICON: 16-bit control register
- SPISTA: 8-bit read-only status register
- SPIDIV: 8-bit serial clock divider register
- SPIRX: 8-bit read-only receive register
- SPITX: 8-bit write-only transmit register

ADuC7032-8L

SPI Control Register

Name: SPICON

Address: 0xFFFF0A10

Default Value: 0x0000

Access: Read/write

Function: This 16-bit MMR configures the serial peripheral interface.

Table 89. SPICON MMR Bit Designations

Bit	Description
15 to 13	Reserved. Should be written as 0.
12	Continuous Transfer Enable. Set by user to enable continuous transfer. In master mode the transfer continues until no valid data is available in the SPITX register. \overline{SS} is asserted and remains asserted for the duration of each 8-bit serial transfer until SPITX is empty. Cleared by user to disable continuous transfer. Each transfer consists of a single 8-bit serial transfer. If valid data exists in the SPITX register, a new transfer is initiated after a stall period.
11	Loop Back Enable. Set by user to connect MISO to MOSI and test software. Cleared by user to normal mode.
10	Slave Output Enable. Set by user to enable slave output. Cleared by user to disable slave output.
9	Slave Select Input Enable. Set by user in master mode to enable the output.
8	SPIRX Overflow Overwrite Enable. Set by user. The valid data in the RX register is overwritten by the new serial byte received. Cleared by user. The new serial byte received is discarded.
7	SPITX Underflow Mode. Set by user to transmit the previous data. Cleared by user to transmit 0.
6	Transfer and Interrupt Mode (Master Mode). Set by user to initiate transfer with a write to the SPITX register. Interrupt occurs when SPITX is empty. Cleared by user to initiate transfer with a read of the SPIRX register. Interrupt occurs when SPIRX is full.
5	LSB First Transfer Enable Bit. Set by user. The LSB is transmitted first. Cleared by user. The MSB is transmitted first.
4	Reserved. Should be written as 0.
3	Serial Clock Polarity Mode Bit. Set by user. The serial clock idles high. Cleared by user. The serial clock idles low.
2	Serial Clock Phase Mode Bit. Set by user. The serial clock pulses at the beginning of each serial bit transfer. Cleared by user. The serial clock pulses at the end of each serial bit transfer.
1	Master Mode Enable Bit. Set by user to enable master mode. Cleared by user to enable slave mode.
0	SPI Enable Bit. Set by user to enable the SPI. Cleared to disable the SPI.

SPI Status Register**Name:** SPISTA**Address:** 0xFFFF0A00**Default Value:** 0x00**Access:** Read only**Function:** This 8-bit MMR represents the current status of the serial peripheral interface.**Table 90. SPISTA MMR Bit Designations**

Bit	Description
7 to 6	Reserved.
5	SPIRX Data Register Overflow Status Bit. Set if SPIRX is overflowing. Cleared by reading SPIRX register.
4	SPIRX Data Register IRQ. Set automatically if Bit 3 or Bit 5 is set. Cleared by reading SPIRX register.
3	SPIRX Data Register Full Status Bit. Set automatically if valid data is present in the SPIRX register. Cleared by reading SPIRX register.
2	SPITX Data Register Underflow Status Bit. Set automatically if SPITX is underflowing. Cleared by writing in the SPITX register.
1	SPITX Data Register IRQ. Set automatically if Bit 0 is cleared or Bit 2 is set. Cleared by writing in the SPITX register or, if transmission finished, by disabling the SPI.
0	SPITX Data Register Empty Status Bit. Set by writing to SPITX to send data. This bit is set during transmission of data. Cleared when SPITX is empty.

SPI Divider Register**Name:** SPIDIV**Address:** 0xFFFF0A0C**Default Value:** 0x1B**Access:** Read/write**Function:** This 8-bit MMR represents the frequency at which the serial peripheral interface is operating. For more information on the calculation of the baud rate, see the SCLK (Serial Clock I/O Pin) section.**SPI Receive Register****Name:** SPIRX**Address:** 0xFFFF0A04**Default Value:** 0x00**Access:** Read only**Function:** This 8-bit MMR contains the data received via the serial peripheral interface.**SPI Transmit Register****Name:** SPITX**Address:** 0xFFFF0A08**Default Value:** 0x00**Access:** Write only**Function:** This 8-bit MMR is written to, to transmit data via the serial peripheral interface.

LIN (LOCAL INTERCONNECT NETWORK) INTERFACE

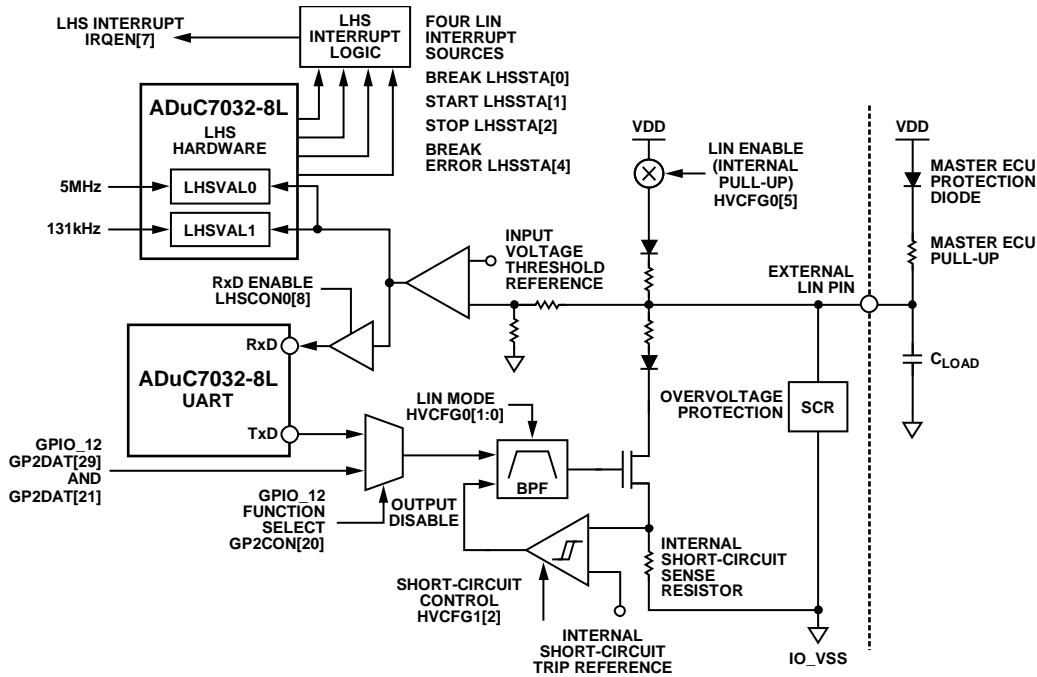

Figure 40. LIN I/O, Block Diagram

The ADuC7032-8L features a high voltage physical interface between the ARM7 MCU core and an external LIN bus. The LIN interface operates as a slave-only interface operating from 1 kBaud to 20 kBaud and is compatible with the LIN 2.0 standard. The pull-up resistor required for a slave node is on-chip, reducing the need for external circuitry. The LIN protocol is emulated using the on-chip UART, an IRQ, a dedicated LIN timer, and the high voltage transceiver, which is also incorporated on-chip. This emulation is shown in Figure 40. The LIN is clocked from the low power oscillator, for the break timer; and a 5 MHz output from the PLL, which is used for the sync byte timing.

LIN MMR DESCRIPTION

The LIN hardware synchronization (LHS) functionality is controlled using the following five MMRs:

- LHSSTA: status register that contains information flags describing the current status of the interface
- LHSCON0: Control Register 0, which controls configuration of the LHS timer
- LHSCON1: start and stop edge control register that dictates at which edge of the LIN synchronization byte the LHS starts or stops counting.
- LHSVAL0: 16-bit timer that is controlled by LHSCON0.
- LHSVAL1: break timer register.

LIN Hardware Synchronization Status Register**Name:** LHSSTA**Address:** 0xFFFF0780**Default Value:** 0x00**Access:** Read only**Function:** This LHS status register is an 8-bit register whose bits reflect the current operating status of the ADuC7032-8L LIN interface.**Table 91. LHSSTA MMR Bit Designations**

Bit	Description
7 to 6	Reserved. These read-only bits are reserved for future use.
5	LHS Reset Complete Flag. Set to 1 by hardware to indicate an LHS reset command has completed successfully. Cleared to 0 after user code reads the LHSSTA MMR.
4	Break Field Error. Set to 1 by hardware and generates an LHS interrupt (IRQEN[7]) when the 12-bit break timer (LHSVAl1) register overflows to indicate the LIN bus has stayed low too long, thus indicating a possible LIN bus error. Cleared to 0 after user code reads the LHSSTA MMR.
3	LHS Compare Interrupt. Set to 1 by hardware when the value in LHSVAl0 (LIN synchronization bit timer) = the value in the LHSCMP register. Cleared to 0 after user code reads the LHSSTA MMR.
2	Stop Condition Interrupt. Set to 1 by hardware when a stop condition is detected. Cleared to 0 after user code reads LHSSTA MMR.
1	Start Condition Interrupt. Set to 1 by hardware when a start condition is detected. Cleared to 0 after user code reads LHSSTA MMR.
0	Break Timer Compare Interrupt. Set to 1 by hardware when a valid LIN break condition is detected. A LIN break condition is generated when the LIN break timer value reaches the break timer compare value (see the LHSVAl1 description in the LIN Hardware Break Timer1 Register section). Cleared to 0 after user code reads the LHSSTA MMR.

ADuC7032-8L

LIN Hardware Synchronization Control Register 0

Name: LHSCON0

Address: 0xFFFF0784

Default Value: 0x0000

Access: Read/write

Function: This LHS control register is a 16-bit register that, in conjunction with the LHSCON1 register, is used to configure the LIN mode of operation.

Table 92. LHSCON0 MMR Bit Designations

Bit	Description
15 to 12	Reserved. These bits are reserved for future use and should be written as 0 by user software.
11	Break Timer Compare Interrupt Disable. Set to 1 to disable the break timer compare interrupt. Cleared to 0 to enable the break timer compare interrupt.
10	Break Timer Error Interrupt Disable. Set to 1 to disable the break timer error interrupt. Cleared to 0 to enable the break timer error interrupt.
9	LIN Transceiver, Standalone Test Mode. Cleared to 0 by user code to operate the LIN in normal mode, driven directly from the on-chip UART. Set to 1 by user code to enable external GPIO_7 and GPIO_8 pins to drive the LIN transceiver TxD and RxD, respectively, independent of the UART. The functions of GPIO_7 and GPIO_8 should first be configured by user code via GPIO Function Select Bit 0 and GPIO Function Select Bit 4 in the GP2CON register.
8	Gate UART Bit. Set to 1 by user code to disable the internal UART RxD (receive data) by gating it high until both the break field and subsequent LIN sync byte have been detected. This ensures the UART does not receive any spurious serial data during break or sync field periods that need to be flushed out of the UART before valid data fields can be received. Set to 0 by user code to enable the internal UART RxD (receive data) after the break field and subsequent LIN sync byte have been detected so that the UART can receive the subsequent LIN data fields.
7	Sync Timer Stop Edge Type Bit. Cleared to 0 by user code to stop the sync timer on the falling edge count configured via the LHSCON1[7:4] register. Set to 1 by user code to stop the sync timer on the rising edge count configured via the LHSCON1[7:4] register.
6 to 5	Reserved. These bits are reserved for future use and should be written as 0 by user software.
4	Enable Stop Interrupt. Cleared to 0 by user code to disable interrupts when a stop condition occurs. Set to 1 by user code to generate an interrupt when a stop condition occurs.
3	Enable Start Interrupt. Cleared to 0 by user code to disable interrupts when a start condition occurs. Set to 1 by user code to generate an interrupt when a start condition occurs.
2	LIN Sync Enable Bit. Cleared to 0 by user code to disable LHS functionality. Set to 1 by user code to enable LHS functionality.
1	Edge Counter Clear Bit. Cleared to 0 by user code to enable the rising or falling edge counters to function normally. Set to 1 by user code to clear the internal edge counters in the LHS peripheral. This bit does not reset to 0 automatically and requires user code to write 0 to re-enable the edge counters.
0	LHS Reset Bit. Cleared to 0 automatically after 15 μ s delay. Set to 1 by user code to reset all LHS logic to default conditions.

LIN Hardware Synchronization Control Register 1**Name:** LHSCON1**Address:** 0xFFFF078C**Default Value:** 0x32**Access:** Read/write**Function:** This LHS control register is an 8-bit register that, in conjunction with the LHSCON0 register, is used to configure the LIN mode of operation.**Table 93. LHSCON1 MMR Bit Designations**

Bit	Description
7 to 4	LIN Stop Edge Count. These four bits are set by user code to the number of falling or rising edges on which to stop the internal LIN synchronization counter. The stop value of this counter can be read by user code via LHSVAL0. The type of edge, either rising or falling, is configured by LHSCON0[7]. The default value of these bits is 0x3, which configures the hardware to stop counting on the third falling edge. It should be noted that the first falling edge is taken as the falling edge at the start of the LIN break pulse.
3 to 0	LIN Start Edge Count. These four bits are set by user code to the number of falling edges after which the internal LIN synchronization timer starts counting. The stop value of this counter can be read by user code via LHSVAL0. The default value of these bits is 0x2, which configures the hardware to start counting on the second falling edge. It should be noted that the first falling edge is taken as the falling edge at the start of the LIN break pulse.

LIN Hardware Synchronization Timer0 Register**Name:** LHSVAL0**Address:** 0xFFFF0788**Default Value:** 0x0000**Access:** Read/write**Function:** This 16-bit read-only register holds the value of the internal LIN synchronization timer. The LIN synchronization timer is clocked from an internal 5 MHz clock that is independent of core clock and baud rate frequency. In LIN mode, the value read by user code from the LHSVAL0 register can be used to calculate the master LIN baud rate. This calculation can then be used to configure the internal UART baud rate to ensure correct LIN communication via the UART from the ADuC7032-8L slave to the LIN master node.**LIN Hardware Break Timer1 Register****Name:** LHSVAL1**Address:** 0xFFFF0790**Default Value:** 0x000 (read) or 0x047 (write)**Access:** Read/write**Function:** When user code reads this location, the 12-bit value returned is the value of the internal LIN break timer, which is clocked directly from the on-chip low power (131 kHz) oscillator and times the LIN break pulse.

A negative edge on the LIN bus or user code reading the LHSVAL1 results in the timer and the register contents being reset to 0. When user code writes to this location, the 12-bit value is actually written not to the LIN break timer, but to a LIN break compare register. In LIN mode of operation, the value in the compare register is continuously compared to the break timer value. A LIN break interrupt (IRQEN[7] and LHSSTA[0]) is generated when the timer value reaches the compare value. After the break condition interrupt, the LIN break timer continues to count until the rising edge of the break signal. If a rising edge is not detected and the 12-bit timer overflows ($4096 \times 1/131 \text{ kHz} = 31 \text{ ms}$), a break field error interrupt (IRQEN[7] and LHSSTA[4]) is generated. By default, the value in the compare register is 0x47, corresponding to 11-bit periods, that is, the minimum pulse width for a LIN break pulse at 20 kbps. For different baud rates, this value can be changed by writing to LHSVAL1. It is also important to note that if a valid break interrupt is not received, subsequent sync pulse timing through the LHSVAL0 register does not occur.

LIN HARDWARE INTERFACE

LIN Frame Protocol

The LIN frame protocol is divided into four main categories: break symbol, sync byte, protected identifier, and data bytes.

The format of the frame header, break, synchronization byte, and protected identifier is shown in Figure 41. Essentially, the embedded UART, LIN hardware synchronization logic, and the high voltage transceiver interface all combine on-chip to support and manage LIN-based transmissions and receptions.

LIN Frame Break Symbol

As shown in Figure 42, the LIN break symbol is used to signal the start of a new frame. It lasts at least 13 bit-periods, and a slave must be able to detect a break symbol, even if it expects data or is in the process of receiving data. The ADuC7032-8L accomplishes this by using the LHSVAL1 break condition and break error-detect functionality. The break period does not need to be accurately measured, but if a bus fault condition (bus held low) occurs, it must be flagged.

LIN Frame Synchronization Byte

The baud rate of the communication via LIN is calculated from the sync byte, as shown in Figure 43. The time between the first falling edge of the sync field and the fifth falling edge of the sync field is measured. The result is divided by 8 to give the baud rate of the data that is to be transmitted. The ADuC7032-8L implements the timing of this sync byte in hardware.

LIN Frame Protected Identifier

After receiving the LIN sync field, the required baud rate for the UART is calculated. The UART is then configured, allowing the ADuC7032-8L to receive the protected identifier, as shown in Figure 44. The protected identifier consists of two sub-fields: the identifier and the identifier parity. The 6-bit identifier contains the identifier of the target for the frame. The identifier signifies the number of data bytes to be either received or transmitted.

The number of bytes is user-configurable at system level design. The parity is calculated on the identifier and is dependent on the revision of LIN for which the system is designed.

LIN Frame Data Byte

The data byte frame carries between one byte and eight bytes of data. The number of bytes contained in the frame is dependent on the LIN master. The data byte frame is split into data bytes, as shown in Figure 45.

LIN Frame Data Transmission and Reception

When the break symbol and synchronization bytes have been correctly received, data is transmitted and received via the COMTX and COMRX MMRs, after configuration of the UART to the required baud rate.

Configuring the UART for use with LIN requires the use of the following UART MMRs:

- COMDIV0: divisor latch (low byte)
- COMDIV1: divisor latch (high byte)
- COMDIV2: 16-bit fractional baud divide register

The required values for COMDIV0, COMDIV1 and COMDIV2 are derived from the LHSVAL0, to generate the required baud rate.

COMCON0 is a line control register. When the UART is correctly configured, the LIN protocol for receiving and transmitting data is identical to the UART specification.

Managing data on the LIN bus requires the use of the following UART MMRs:

- COMTX: 8-bit transmit register
- COMRX: 8-bit receive register
- COMCON0: line control register
- COMSTA0: line status register

Transmitting data on the LIN bus requires that the relevant data be placed into COMTX. Reading data received on the LIN bus requires the monitoring of COMRX. To ensure that data is received or transmitted correctly, COMSTA0 is monitored. For more information, see the UART Serial Interface section.

Under software control, it is possible to multiplex the UART data lines (TxD and RxD) to external GPIO pins (GPIO_7 and GPIO_8). For more information, see the description of the GPIO Port1 Control Register (GP1CON).

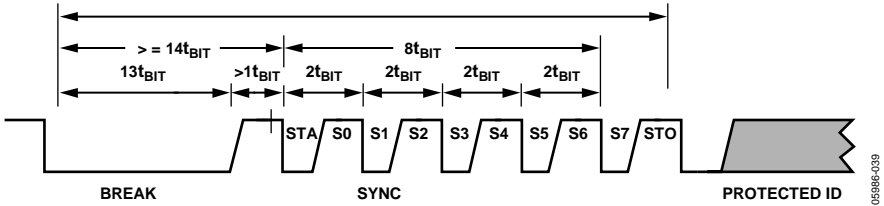

Figure 41. LIN Interface Timing

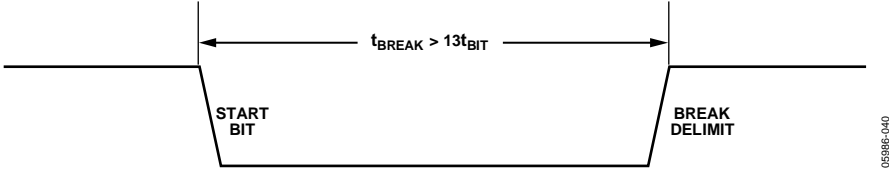

Figure 42. LIN Break Field

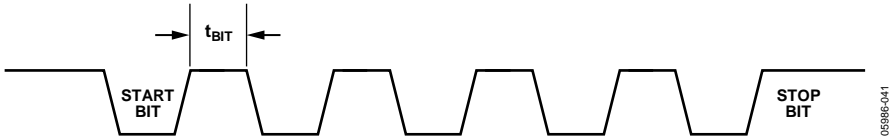

Figure 43. LIN Sync Byte Field

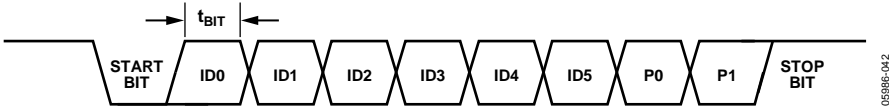

Figure 44. LIN Identifier Byte Field

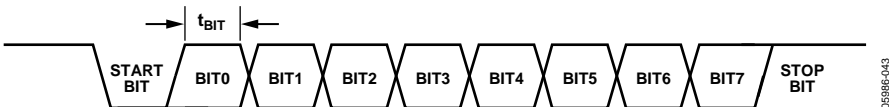

Figure 45. LIN Data Byte Field

Example LIN Hardware Synchronization Routine

Consider the following C-source code LIN initialization routine:

```
void LIN_INIT(void )
{
    char HVstatus;
    GP2CON = 0x110000;           // Enable LHS on GPIO pins

    LHSCON0 = 0x1;              // Reset LHS interface

    do{
        HVDAT = 0x02;           // Enable normal LIN TX mode
        HVCON = 0x08;           // Write to Config0
        do{
            HVstatus = HVCON;
        }
        while(HVstatus & 0x1); // Wait until command is finished
    }
    while (!(HVstatus & 0x4)); // Transmit command is correct

    while((LHSSSTA & 0x20) == 0 )
    {
        // Wait until the LHS hardware is reset
    }

    LHSCON1 = 0x062;           // Sets stop edge as the fifth falling edge
                                // and the start edge as the first falling
                                // edge in the sync byte
    LHSCON0 = 0x0114;           // Gates UART RX line, ensure no interference
                                // from the LIN into the UART
                                // Selects the stop condition as a falling edge
                                // Enables generation of an interrupt on the
                                // stop condition
                                // Enables the interface
    LHSVAL1 = 0x03F;           // Set number of 131 kHz periods to generate
                                // a break interrupt 0x3F / 131 kHz ~ 480 µs
                                // which is just over 9.5 tbits
}
}
```

Using this configuration, LHSVAL1 begins to count on the first falling edge received on the LIN bus. If LHSVAL1 exceeds the value written to LHSVAL1, in this case 0x3F, a break compare interrupt is generated.

On the next falling edge, LHSVAL0 begins counting. LHSVAL0 monitors the number of falling edges and compares this number to the value written to LHSCON1. In this example, the edge to monitor is the sixth falling edge of the LIN frame, or the fifth falling edge of the sync byte.

After the number of falling edges is received, a stop condition interrupt is generated. It is at this point that the UART is configured to receive the protected identifier.

The UART must not be ungated, through LHSCON0[8], before the LIN bus returns high. If this occurs, UART communication errors may occur. This process is shown in detail in Figure 46. Example code follows.

Example Code

```

while((GP2DAT & 0x10 ) == 0 )
{
    // Wait until LIN bus returns high
    LHSCON0 = 0x4;           // Enable LHS to detect break condition ungate
    // RX line
    // Disable all interrupts except break compare
    // interrupt
    IRQEN = 0x800;         // Enable UART interrupt
    // The UART is now configured and ready to be used
    // for LIN
}

```

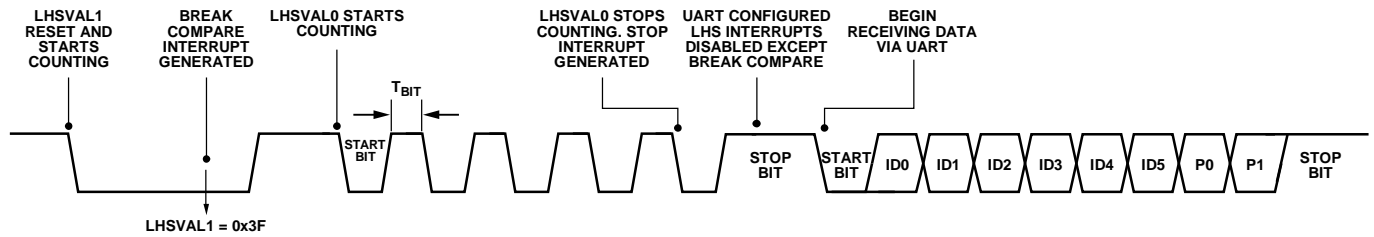

Figure 46. Example LIN Configuration

LIN Diagnostics

The ADuC7032-8L features the capability to nonintrusively monitor the current state of the LIN pin. This readback functionality is implemented via GPIO_11. The current state of the LIN pin is contained in GP2DAT[4].

It is also possible to drive the LIN pin high and low via user software, allowing the user to detect open-circuit conditions. This functionality is implemented via GPIO_12.

To enable this functionality, GPIO_12 must be configured as a GPIO via GP2CON[20]. Once configured, the LIN pin can be pulled high or low via GP2DAT.

The ADuC7032-8L also features short-circuit protection on the LIN pin. If a short-circuit condition is detected on the LIN pin, HVSTA[2] is set. This bit is cleared by re-enabling the LIN driver via HVCFG1[3]. It is possible to disable this feature via HVCFG1[2].

ADuC7032-8L ON-CHIP DIAGNOSTICS

The ADuC7032-8L integrates multiple diagnostic support circuits on-chip. These circuits allow the device to test core digital functionality, and analog front-end and high voltage I/O ports in-circuit.

ADC DIAGNOSTICS

Internal Test Voltage

The current channel can be configured to convert on an internal 8.3 mV test voltage. On any gain range, the result should be within $\pm 2\%$ of the expected result.

Internal Short Mode

The current and voltage input channels can also be shorted internally. Converting on the internal short allows an assessment of the internal ADC noise.

Internal Current Sources

Internal current sources can also be enabled on both current and temperature channels. These current sources can be used to determine external short-circuit or open-circuit conditions in both external shunt or temperature sensor configurations.

HIGH VOLTAGE I/O DIAGNOSTICS

High Voltage I/O Readback

All high voltage I/O pins are supported with readback capability, which allows the detection of external short conditions.

High Voltage Current Detection

All high voltage I/O pins also have a high current detection capability, allowing high-side connections to VBAT to be detected and controlled.

PART IDENTIFICATION

Two registers mapped into the MMR space are intended to allow user code to identify and trace by manufacturing lot ID information, part ID number, silicon mask revision, and kernel revision. This information is contained in the SYSSER0 and SYSSER1 MMRs that are described in detail in Table 94 and Table 96.

For full traceability, the part assembly lot number, SYSSER0, SYSSER1, and module number need to be recorded. The lot number is part of the branding on the package, as shown in Table 95. Silicon revision and kernel revision information is contained in two MMRs, SYSSER1 and FEE0ADR.

System Serial ID Register 0

Name: SYSSER0

Address: 0xFFFF0238

Default Value: 0x00000000 (updated by kernel at power-on)

Access: Read/write

Function: At power-on, this 32-bit register holds the value of the original manufacturing lot number from which this specific ADuC7032-8L unit was manufactured (bottom die only). Used in conjunction with SYSSER1, this lot number allows the full manufacturing history of this part to be traced (bottom die only).

Table 94. SYSSER0 MMR Bit Designations

Bit	Description
31 to 27	Wafer Number. The five bits read from this location give the wafer number (1 to 24) from the wafer fabrication lot ID from which this device originated and, when used in conjunction with SYSSER0[26:0], provide individual wafer traceability.
26 to 22	Wafer Lot Fabrication Plant. The five bits read from this location reflect the manufacturing plant associated with this wafer lot and, used in conjunction with SYSSER0[21:0], provide wafer lot traceability.
21 to 16	Wafer Lot Fabrication ID. The six bits read from this location form part of the wafer lot fabrication ID and, used in conjunction with SYSSER0[26:22] and SYSSER0[15:0], provide wafer lot traceability.
15 to 0	Wafer Lot Fabrication ID. These 16 LSBs hold a 16-bit number that should be interpreted as the wafer fabrication lot ID number. When used in conjunction with the value in SYSSER1, that is, the manufacturing lot ID, this number is a unique identifier for the part.

Table 95. Branding Example

Line No.	LQFP
Line 1	ADuC7032-8L
Line 2	BSTZ 8L
Line 3	A40 #date code
Line 4	Assembly lot number

ADuC7032-8L

System Serial ID Register 1

Name: SYSSER1

Address: 0xFFFF023C

Default Value: 0x00000000 (updated by kernel at power-on)

Access: Read/write

Function: At power-on, this 32-bit register holds the values of the part ID number, silicon mask revision number, and kernel revision number (bottom die only), as detailed in Table 96.

Table 96. SYSSER1 MMR Bit Designations

Bit	Description
31 to 28	Silicon Mask Revision ID. The four bits read from this nibble reflect the silicon mask ID number. Specifically, the hex value in this nibble should be decoded as the lower hex nibble in the hex numbers reflecting the ASCII characters in the range A to O. Examples: Bits[19:16] = 0001 = 0x1; therefore, this value should be interpreted as 41, which is ASCII Character A, corresponding to Silicon Mask Revision A. Bits[19:16] = 1011 = 0xB; therefore, the number is interpreted as 4B, which is ASCII Character K, corresponding to Silicon Mask Revision K. The allowable range for this value is 1 to 15, that is, interpreted as 41 to 4F, or ASCII Character A to ASCII Character O.
27 to 20	Kernel Revision ID. This byte contains the hex number that should be interpreted as an ASCII character indicating the revision of the kernel firmware embedded in the on-chip Flash/EE memory. Example: Reading 0x41 from this byte should be interpreted as A, indicating a Revision A kernel is on-chip.
19 to 16	Reserved. Note that for prerelease samples, these bits refer to the kernel minor revision number of the device.
15 to 0	Part ID. These 16 LSBs hold a 16-bit number that should be interpreted as the part ID number. When used in conjunction with the value in SYSSER0, that is, the manufacturing lot ID; this number is a unique identifier for the part.

System Kernel Checksum

Name: SYSCHK

Address: 0xFFFF0240

Default Value: 0x00000000 (updated by kernel at power-on)

Access: Read/write

Function: At power-on, this 32-bit register holds the kernel checksum.

System Identification FEE0ADR**Name:** FEE0ADR**Address:** 0xFFFF0E10**Default Value:** Nonzero**Access:** Read/write

Function: This 16-bit register dictates the address upon which any Flash/EE command executed via FEEExCON acts. Note that this MMR is also used to identify ADuC703x family members and prerelease silicon revision.

Table 97. FEE0ADR System Identification MMR Bit Designations

Bit	Description
15 to 12	Reserved.
11 to 8	Reserved.
7 to 4	Silicon Revision. 0x0 = Type6 0x1 = Type6X 0x4 = Type7Y 0x5 = Type7OP 0x6 = Type8 0x7 = Type7OP1 0x8 = Type7M 0x9 = Type7 0xA = Type8W 0xC = Type7ML 0xD = Type8V 0xE = Type8Y 0xF = Type8L Others = reserved
3 to 0	ADuC7030 Family ID. 0x0 = ADuC7030 0x2 = ADuC7032 0x3 = ADuC7033 Others = reserved

ADuC7032-8L

ADuC7032-8L EXAMPLE SCHEMATIC

This example schematic represents a basic functional circuit implementation. Additional components must be added to ensure the system meets any EMC and other overvoltage/overcurrent compliance requirements.

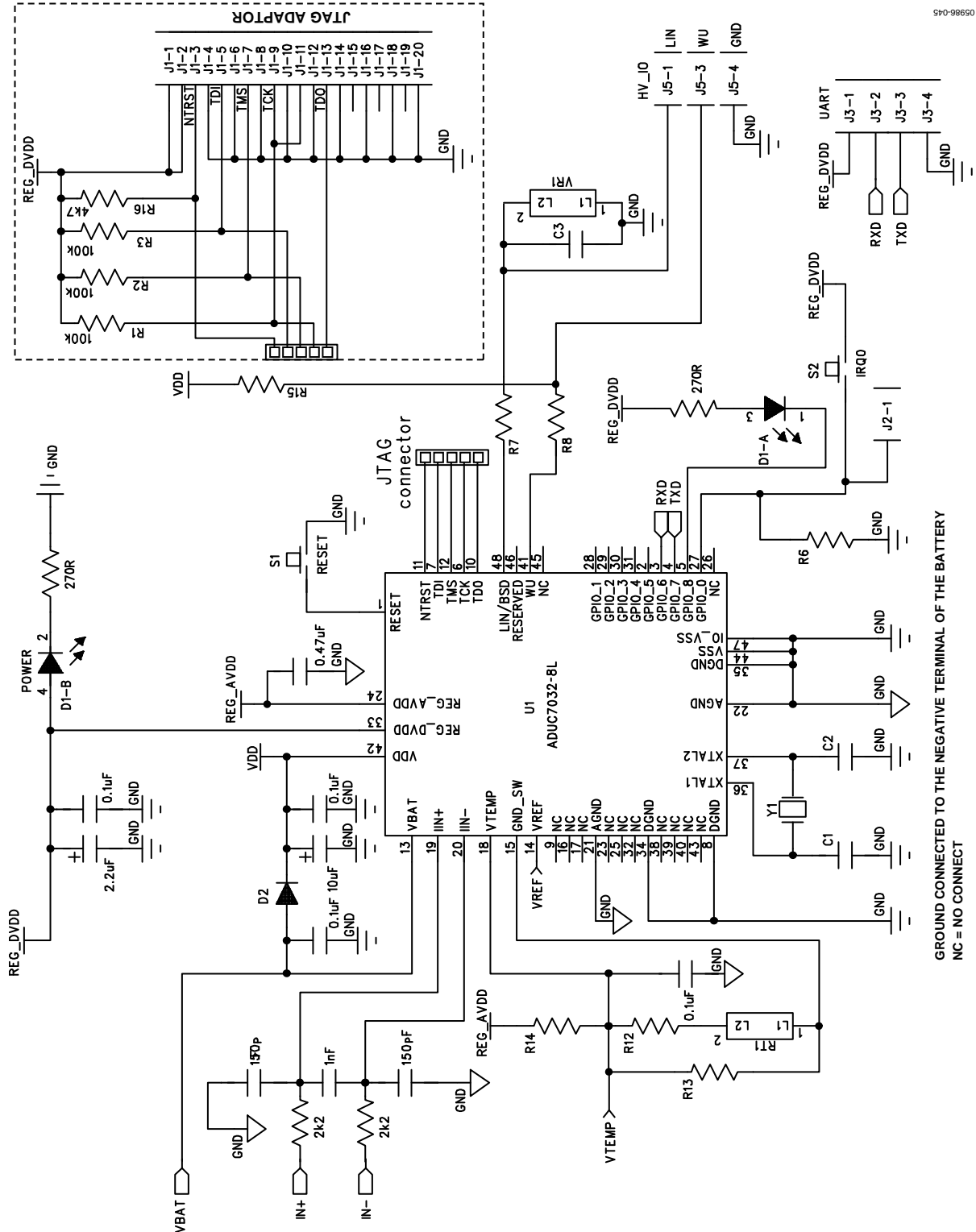
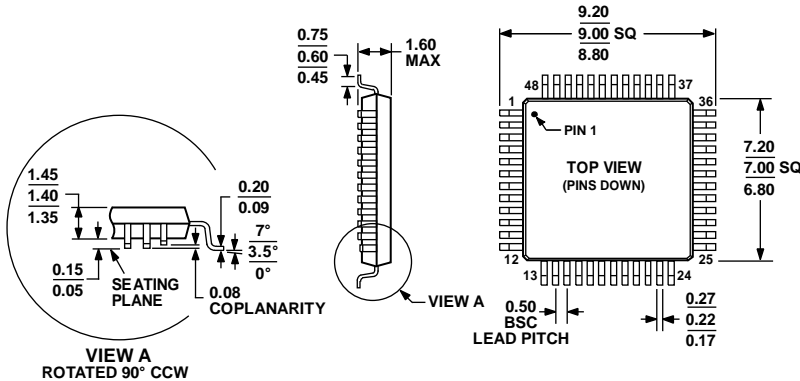

Figure 47. Basic Functional Circuit Implementation

OUTLINE DIMENSIONS



COMPLIANT TO JEDEC STANDARDS MS-026-BBC
 Figure 48. 48-Lead Low Profile Quad Flat Package [LQFP]
 (ST-48)
 Dimensions shown in millimeters

051706-A

ORDERING GUIDE

Model ¹	Temperature Range	Package Description	Package Option
ADuC7032BSTZ-8L	-40°C to +105°C	48-Lead Low Profile Quad Flat Package [LQFP], Reel	ST-48
ADuC7032BSTZ-8L-RL	-40°C to +105°C	48-Lead Low Profile Quad Flat Package [LQFP], Reel	ST-48
ADuC7032BSTZ-88	-40°C to +105°C	48-Lead Low Profile Quad Flat Package [LQFP], Reel	ST-48
ADuC7032BSTZ-88-RL	-40°C to +105°C	48-Lead Low Profile Quad Flat Package [LQFP], Reel	ST-48

¹ Z = RoHS Compliant Part.

ADuC7032-8L

NOTES

NOTES

NOTES

Looking for pricing, stock, or lifecycle information?

Click below to explore more details on WIN SOURCE:

 [View ADUC7032BSTZ-88 on WIN SOURCE](#)

 [Analog Devices Inc. Information](#)

Optimize Your Supply Chain with WIN SOURCE Solutions

-  Global Sourcing Solution
-  Obsolete Management
-  Cost Control Management
-  Shortage Management
-  Alternative Solution
-  Excess Inventory Management