



**THE DATASHEET OF
S29JL064J60TFI003**





Please note that Cypress is an Infineon Technologies Company.

The document following this cover page is marked as “Cypress” document as this is the company that originally developed the product. Please note that Infineon will continue to offer the product to new and existing customers as part of the Infineon product portfolio.

Continuity of document content

The fact that Infineon offers the following product as part of the Infineon product portfolio does not lead to any changes to this document. Future revisions will occur when appropriate, and any changes will be set out on the document history page.

Continuity of ordering part numbers

Infineon continues to support existing part numbers. Please continue to use the ordering part numbers listed in the datasheet for ordering.

64-Mb (8M × 8-Bit/4M × 16-Bit), 3 V, Simultaneous Read/Write Flash

Distinctive Characteristics

Architectural Advantages

- Simultaneous Read/Write operations
 - Data can be continuously read from one bank while executing erase/program functions in another bank
 - Zero latency between read and write operations
- Flexible bank architecture
 - Read may occur in any of the three banks not being programmed or erased
 - Four banks may be grouped by customer to achieve desired bank divisions
- Boot sectors
 - Top and bottom boot sectors in the same device
 - Any combination of sectors can be erased
- Manufactured on 0.11 μm Process Technology
- Secured Silicon Region: **Extra 256-byte sector**
 - *Factory locked and identifiable*: 16 bytes available for secure, random factory Electronic Serial Number; verifiable as factory locked through autoselect function
 - *Customer lockable*: One-time programmable only. Once locked, data cannot be changed
- Zero power operation
 - Sophisticated power management circuits reduce power consumed during inactive periods to nearly zero
- Compatible with JEDEC standards
 - Pinout and software compatible with single-power-supply flash standard

Package Options

- 48-ball Fine-pitch BGA
- 48-pin TSOP

Performance Characteristics

- High performance
 - Access time as fast as 55 ns
 - Program time: 7 μs/word typical using accelerated programming function

- Ultra low power consumption (typical values)
 - 2 mA active read current at 1 MHz
 - 10 mA active read current at 5 MHz
 - 200 nA in standby or automatic sleep mode
- Cycling endurance: 1 million cycles per sector typical
- Data retention: 20 years typical

Software Features

- Supports Common Flash Memory Interface (CFI)
- Erase suspend/erase resume
 - Suspends erase operations to read data from, or program data to, a sector that is not being erased, then resumes the erase operation
- Data# polling and toggle bits
 - Provides a software method of detecting the status of program or erase operations
- Unlock bypass program command
 - Reduces overall programming time when issuing multiple program command sequences

Hardware Features

- Ready/Busy# output (RY/BY#)
 - Hardware method for detecting program or erase cycle completion
- Hardware reset pin (RESET#)
 - Hardware method of resetting the internal state machine to the read mode
- WP#/ACC input pin
 - Write protect (WP#) function protects sectors 0, 1, 140, and 141, regardless of sector protect status
 - Acceleration (ACC) function accelerates program timing
- Sector Protection
 - Hardware method to prevent any program or erase operation within a sector
 - Temporary Sector Unprotect allows changing data in protected sectors in-system

General Description

The S29JL064J is a 64 Mb, 3.0 volt-only flash memory device, organized as 4,194,304 words of 16 bits each or 8,388,608 bytes of 8 bits each. Word mode data appears on DQ15–DQ0; byte mode data appears on DQ7–DQ0. The device is designed to be programmed in-system with the standard 3.0 volt V_{CC} supply, and can also be programmed in standard EPROM programmers. The device is available with an access time of 55, 60, 70 ns and is offered in a 48-ball FBGA or 48-pin TSOP package. Standard control pins—chip enable (CE#), write enable (WE#), and output enable (OE#)—control normal read and write operations, and avoid bus contention issues. The device requires only a **single 3.0 volt power supply** for both read and write functions. Internally generated and regulated voltages are provided for the program and erase operations.

Contents

1. Simultaneous Read/Write Operations with Zero Latency	3	11. Write Operation Status	34
1.1 S29JL064J Features	3	11.1 DQ7: Data# Polling	34
2. Product Selector Guide	4	11.2 RY/BY#: Ready/Busy#	35
3. Block Diagram	4	11.3 DQ6: Toggle Bit I	36
4. Connection Diagrams	5	11.4 DQ2: Toggle Bit II	37
4.1 48-pin TSOP Package	5	11.5 Reading Toggle Bits DQ6/DQ2	37
4.2 48-ball FBGA Package	5	11.6 DQ5: Exceeded Timing Limits	37
5. Pin Description	6	11.7 DQ3: Sector Erase Timer	38
6. Logic Symbol	7	12. Absolute Maximum Ratings	39
7. Ordering Information	8	13. Operating Ranges	40
8. Device Bus Operations	10	14. DC Characteristics	41
8.1 Word/Byte Configuration	10	14.1 CMOS Compatible	41
8.2 Requirements for Reading Array Data	11	14.2 Zero-Power Flash	42
8.3 Writing Commands/Command Sequences	11	15. Test Conditions	43
8.4 Simultaneous Read/Write Operations with Zero Latency	12	16. Key To Switching Waveforms	44
8.5 Standby Mode	12	17. AC Characteristics	45
8.6 Automatic Sleep Mode	12	17.1 Read-Only Operations	45
8.7 RESET#: Hardware Reset Pin	12	17.2 Hardware Reset (RESET#)	46
8.8 Output Disable Mode	13	17.3 Word/Byte Configuration (BYTE#)	47
8.9 Autoselect Mode	17	17.4 Erase and Program Operations	48
8.10 Boot Sector/Sector Block Protection and Unprotection	18	17.5 Temporary Sector Unprotect	52
8.11 Write Protect (WP#)	19	17.6 Alternate CE# Controlled Erase and Program Operations	54
8.12 Temporary Sector Unprotect	20	18. Erase and Programming Performance	56
8.13 Secured Silicon Region	22	19. Pin Capacitance	57
8.14 Hardware Data Protection	23	20. Physical Dimensions	58
9. Common Flash Memory Interface (CFI)	24	20.1 TS 048—48-Pin Standard TSOP	58
10. Command Definitions	27	20.2 VBK048—48-Pin FBGA	59
10.1 Reading Array Data	27	21. Revision History	60
10.2 Reset Command	27	Document History Page	60
10.3 Autoselect Command Sequence	28	Sales, Solutions, and Legal Information	63
10.4 Enter Secured Silicon Region/Exit Secured Silicon Region Command Sequence	28	Worldwide Sales and Design Support	63
10.5 Byte/Word Program Command Sequence	28	Products	63
10.6 Chip Erase Command Sequence	30	PSoC® Solutions	63
10.7 Sector Erase Command Sequence	30	Cypress Developer Community	63
10.8 Erase Suspend/Erase Resume Commands	31	Technical Support	63

1. Simultaneous Read/Write Operations with Zero Latency

The Simultaneous Read/Write architecture provides **simultaneous operation** by dividing the memory space into **four banks**, two 8 Mb banks with small and large sectors, and two 24 Mb banks of large sectors. Sector addresses are fixed, system software can be used to form user-defined bank groups.

During an Erase/Program operation, any of the three non-busy banks may be read from. Note that only two banks can operate simultaneously. The device can improve overall system performance by allowing a host system to program or erase in one bank, then immediately and simultaneously read from the other bank, with zero latency. This releases the system from waiting for the completion of program or erase operations.

The S29JL064J is organized as a dual boot device with both top and bottom boot sectors.

Bank	Mbs	Sector Sizes
Bank 1	8 Mb	Eight 8 KB/4 kword, Fifteen 64 KB/32 kword
Bank 2	24 Mb	Forty-eight 64 KB/32 kword
Bank 3	24 Mb	Forty-eight 64 KB/32 kword
Bank 4	8 Mb	Eight 8 KB/4 kword, Fifteen 64 KB/32 kword

1.1 S29JL064J Features

The **Secured Silicon Region** is an extra 256 byte sector capable of being permanently locked by Cypress or customers. The Secured Silicon Customer Indicator Bit (DQ6) is permanently set to 1 if the part has been customer locked, and permanently set to 0 if the part has been factory locked. This way, customer lockable parts can never be used to replace a factory locked part.

Factory locked parts provide several options. The Secured Silicon Region may store a secure, random 16 byte ESN (Electronic Serial Number), customer code (programmed through Cypress programming services), or both. Customer Lockable parts may utilize the Secured Silicon Region as bonus space, reading and writing like any other flash sector, or may permanently lock their own code there.

The device offers complete compatibility with the **JEDEC 42.4 single-power-supply Flash command set standard**. Commands are written to the command register using standard microprocessor write timings. Reading data out of the device is similar to reading from other Flash or EPROM devices.

The host system can detect whether a program or erase operation is complete by using the device **status bits**: RY/BY# pin, DQ7 (Data# Polling) and DQ6/DQ2 (toggle bits). After a program or erase cycle has been completed, the device automatically returns to the read mode.

The **sector erase architecture** allows memory sectors to be erased and reprogrammed without affecting the data contents of other sectors. The device is fully erased when shipped from the factory.

Hardware data protection measures include a low V_{CC} detector that automatically inhibits write operations during power transitions. The **hardware sector protection** feature disables both program and erase operations in any combination of the sectors of memory. This can be achieved in-system or via programming equipment.

The **Erase Suspend/Erase Resume** feature enables the user to put erase on hold for any period of time to read data from, or program data to, any sector that is not selected for erasure. True background erase can thus be achieved. If a read is needed from the Secured Silicon Region (One Time Program area) after an erase suspend, then the user must use the proper command sequence to enter and exit this region.

The device offers two power-saving features. When addresses have been stable for a specified amount of time, the device enters the **automatic sleep mode**. The system can also place the device into the **standby mode**. Power consumption is greatly reduced in both modes.

2. Product Selector Guide

Part Number		S29JL064J		
Speed Option	Standard Voltage Range: $V_{CC} = 2.7-3.6V$	55	60	70
Max Access Time (ns), t_{ACC}		55	60	70
CE# Access (ns), t_{CE}		55	60	70
OE# Access (ns), t_{OE}		25	25	30

3. Block Diagram

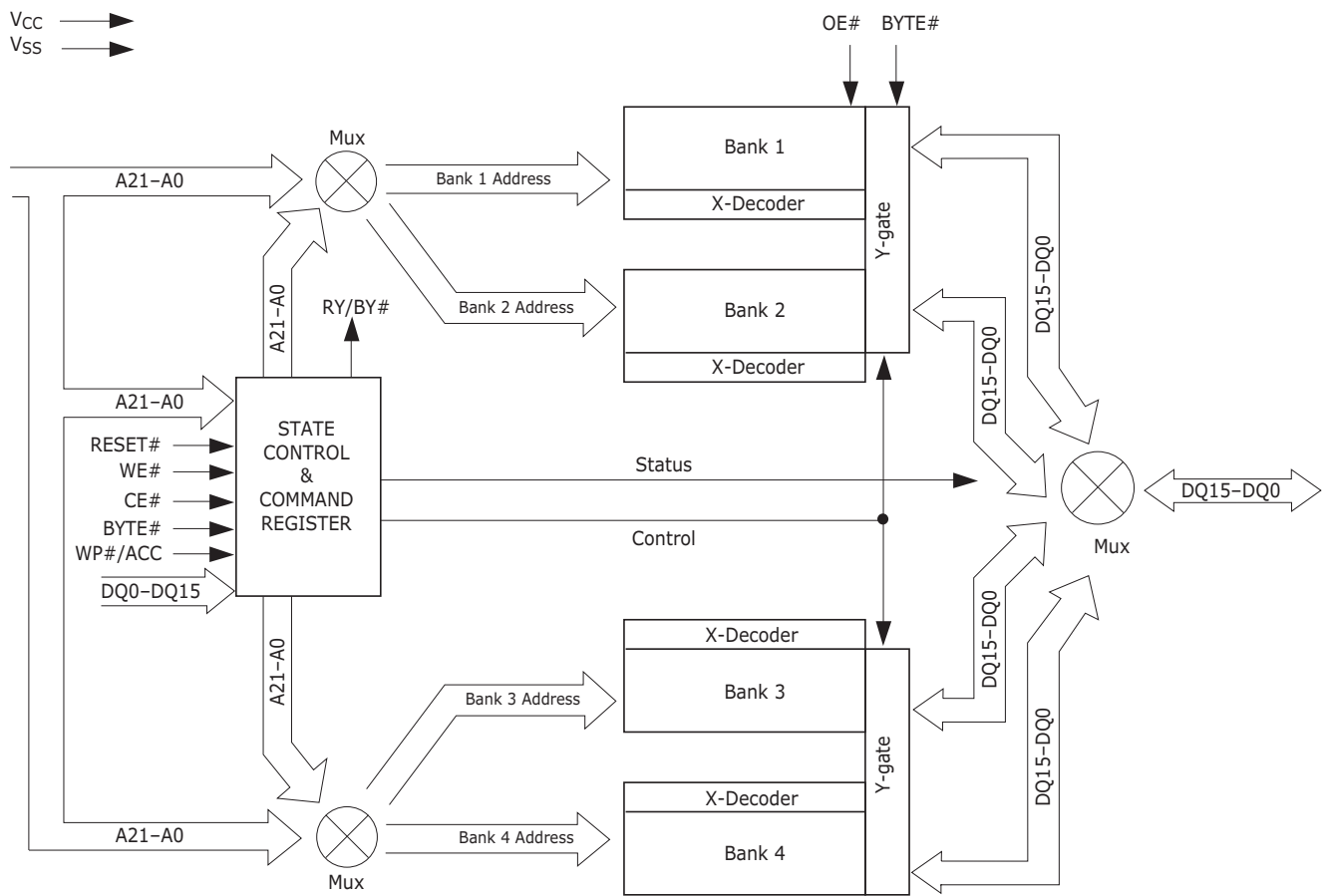

4. Connection Diagrams

4.1 48-pin TSOP Package

Figure 1. 48-Pin Standard TSOP

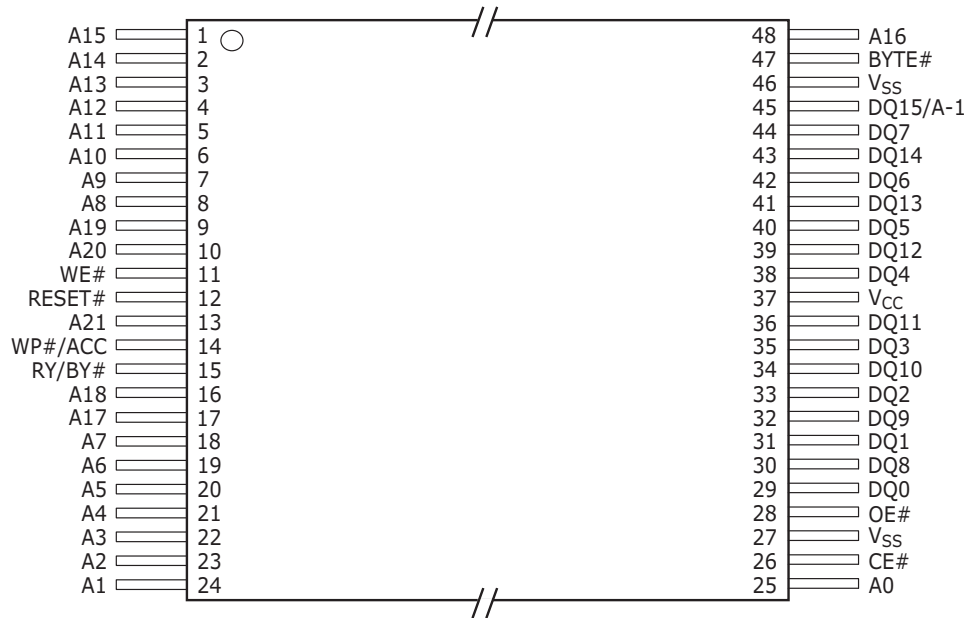

4.2 48-ball FBGA Package

Figure 2. 48-ball FBGA

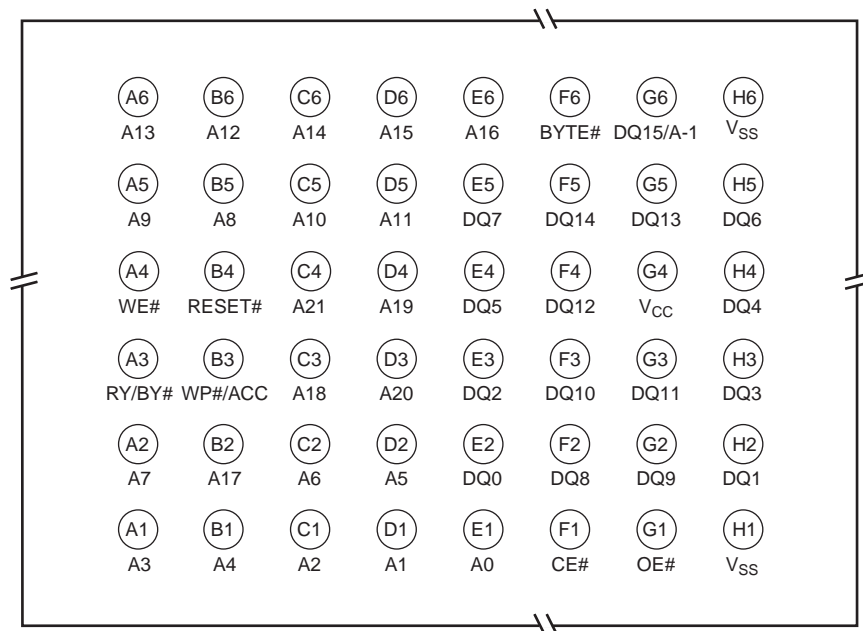

5. Pin Description

Table 1.

A21–A0	22 Address pins
DQ14–DQ0	15 Data Inputs/Outputs (x16-only devices)
DQ15/A-1	DQ15 (Data Input/Output, word mode), A-1 (LSB Address Input, byte mode)
CE#	Chip Enable, Active Low
OE#	Output Enable, Active Low
WE#	Write Enable, Active Low
WP#/ACC	Hardware Write Protect/Acceleration Pin
RESET#	Hardware Reset Pin, Active Low
BYTE#	Selects 8-bit or 16-bit mode, Active Low
RY/BY#	Ready/Busy Output, Active Low
V _{CC}	3.0 volt-only single power supply (see Section 2. Product Selector Guide on page 4 for speed options and voltage supply tolerances)
V _{SS}	Device Ground
NC	Not Connected. No device internal signal is connected to the package connector nor is there any future plan to use the connector for a signal. The connection may safely be used for routing space for a signal on a Printed Circuit Board (PCB).
DNU	Do Not Use. A device internal signal may be connected to the package connector. The connection may be used by Cypress for test or other purposes and is not intended for connection to any host system signal. Any DNU signal related function will be inactive when the signal is at V _{IL} . The signal has an internal pull-down resistor and may be left unconnected in the host system or may be tied to V _{SS} . Do not use these connections for PCB signal routing channels. Do not connect any host system signal to these connections.
RFU	Reserved for Future Use. No device internal signal is currently connected to the package connector but there is potential future use for the connector for a signal. It is recommended to not use RFU connectors for PCB routing channels so that the PCB may take advantage of future enhanced features in compatible footprint devices.

6. Logic Symbol

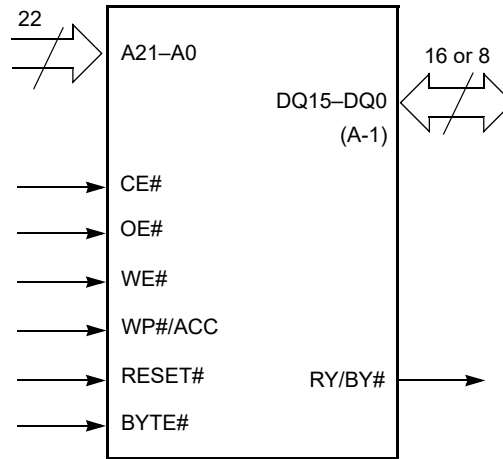

7. Ordering Information

The order number is formed by a valid combination of the following:

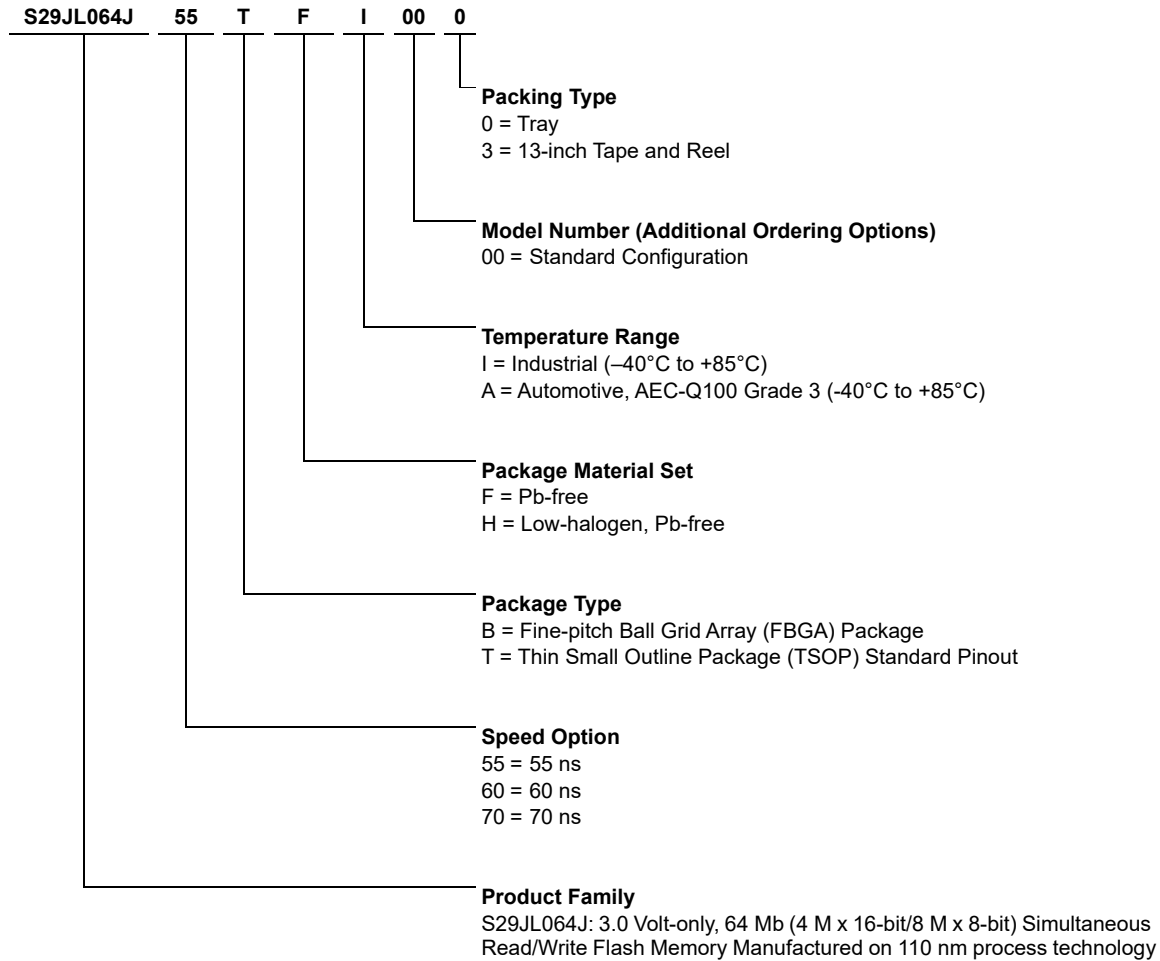

Note

1. Packing type 0 is standard. Specify other options as required.

Valid Combinations — Standard

S29JL064J Valid Combinations							
Device Number/ Description	Speed (ns)	Package Type and Material	Temperature Range	Model Number	Packing Type	Package Description	
S29JL064J	55, 70	TF	I	00	0, 3 ^[1]	TS048	TSOP
		BH				VBK048	FBGA

Valid Combinations — Automotive Grade / AEC-Q100

The table below lists configurations that are Automotive Grade / AEC-Q100 qualified and are planned to be available in volume. The table will be updated as new combinations are released. Consult your local sales representative to confirm availability of specific combinations and to check on newly released combinations.

Production Part Approval Process (PPAP) support is only provided for AEC-Q100 grade products.

Products to be used in end-use applications that require ISO/TS-16949 compliance must be AEC-Q100 grade products in combination with PPAP. Non-AEC-Q100 grade products are not manufactured or documented in full compliance with ISO/TS-16949 requirements.

AEC-Q100 grade products are also offered without PPAP support for end-use applications that do not require ISO/TS-16949 compliance.

S29JL064J Valid Combination - Automotive						
Device Number	Speed (ns)	Package Type and Material	Temperature Range	Model Number	Packing Type	Package Description
S29JL064J	60, 70	BH	A	00	0, 3	FBGA
		TF				TSOP
	55	0				

8. Device Bus Operations

This section describes the requirements and use of the device bus operations, which are initiated through the internal command register. The command register itself does not occupy any addressable memory location. The register is a latch used to store the commands, along with the address and data information needed to execute the command. The contents of the register serve as inputs to the internal state machine. The state machine outputs dictate the function of the device. [Table 2](#) lists the device bus operations, the inputs and control levels they require, and the resulting output. The following subsections describe each of these operations in further detail.

Table 2. S29JL064J Device Bus Operations

Operation	CE#	OE#	WE#	RESET#	WP#/ACC	Addresses ^[1]	DQ15–DQ8		DQ7–DQ0
							BYTE# = V _{IH}	BYTE# = V _{IL}	
Read	L	L	H	H	L/H	A _{IN}	D _{OUT}	DQ14–DQ8 = High-Z, DQ15 = A-1	D _{OUT}
Write	L	H	L	H	Note [3]	A _{IN}	D _{IN}		D _{IN}
Standby	V _{CC} ± 0.3V	X	X	V _{CC} ± 0.3V	L/H	X	High-Z	High-Z	High-Z
Output Disable	L	H	H	H	L/H	X	High-Z	High-Z	High-Z
Reset	X	X	X	L	L/H	X	High-Z	High-Z	High-Z
Sector Protect ^[2]	L	H	L	V _{ID}	L/H	SA, A6 = L, A1 = H, A0 = L	X	X	D _{IN}
Sector Unprotect ^[2]	L	H	L	V _{ID}	Note [3]	SA, A6 = H, A1 = H, A0 = L	X	X	D _{IN}
Temporary Sector Unprotect	X	X	X	V _{ID}	Note [3]	A _{IN}	D _{IN}	High-Z	D _{IN}

Legend

L = Logic Low = V_{IL}
H = Logic High = V_{IH}
V_{ID} = 11.5–12.5V
V_{HH} = 9.0 ± 0.5V
X = Don't Care
SA = Sector Address
A_{IN} = Address In
D_{IN} = Data In
D_{OUT} = Data Out

8.1 Word/Byte Configuration

The BYTE# pin controls whether the device data I/O pins operate in the byte or word configuration. If the BYTE# pin is set at logic '1', the device is in word configuration, DQ15–DQ0 are active and controlled by CE# and OE#.

If the BYTE# pin is set at logic '0', the device is in byte configuration, and only data I/O pins DQ7–DQ0 are active and controlled by CE# and OE#. The data I/O pins DQ14–DQ8 are tri-stated, and the DQ15 pin is used as an input for the LSB (A-1) address function.

Notes

- Addresses are A21:A0 in word mode (BYTE# = V_{IH}), A21:A-1 in byte mode (BYTE# = V_{IL}).
- The sector protect and sector unprotect functions may also be implemented via programming equipment. See [Section 8.10 Boot Sector/Sector Block Protection and Unprotection on page 18](#).
- If WP#/ACC = V_{IL}, sectors 0, 1, 140, and 141 remain protected. If WP#/ACC = V_{IH}, protection on sectors 0, 1, 140, and 141 depends on whether they were last protected or unprotected using the method described in [Section 8.10 Boot Sector/Sector Block Protection and Unprotection on page 18](#). If WP#/ACC = V_{HH}, all sectors will be unprotected.

8.2 Requirements for Reading Array Data

To read array data from the outputs, the system must drive the CE# and OE# pins to V_{IL} . CE# is the power control and selects the device. OE# is the output control and gates array data to the output pins. WE# should remain at V_{IH} . The BYTE# pin determines whether the device outputs array data in words or bytes.

The internal state machine is set for reading array data upon device power-up, or after a hardware reset. This ensures that no spurious alteration of the memory content occurs during the power transition. No command is necessary in this mode to obtain array data. Standard microprocessor read cycles that assert valid addresses on the device address inputs produce valid data on the device data outputs. Each bank remains enabled for read access until the command register contents are altered.

Refer to [Section 17.1 Read-Only Operations on page 45](#) for timing specifications and to [Figure 16 on page 45](#) for the timing diagram. I_{CC1} in [Section 14. DC Characteristics on page 41](#) represents the active current specification for reading array data.

8.3 Writing Commands/Command Sequences

To write a command or command sequence (which includes programming data to the device and erasing sectors of memory), the system must drive WE# and CE# to V_{IL} , and OE# to V_{IH} .

For program operations, the BYTE# pin determines whether the device accepts program data in bytes or words. Refer to [Section 8.1 Word/Byte Configuration on page 10](#) for more information.

The device features an **Unlock Bypass** mode to facilitate faster programming. Once a bank enters the Unlock Bypass mode, only two write cycles are required to program a word or byte, instead of four. [Section 10.5 Byte/Word Program Command Sequence on page 28](#) has details on programming data to the device using both standard and Unlock Bypass command sequences.

An erase operation can erase one sector, multiple sectors, or the entire device. [Table 4 on page 16](#) indicates the address space that each sector occupies. Similarly, a *sector address* is the address bits required to uniquely select a sector. [Section 10. Command Definitions on page 27](#) has details on erasing a sector or the entire chip, or suspending/resuming the erase operation.

The device address space is divided into four banks. A *bank address* is the address bits required to uniquely select a bank.

I_{CC2} in the [DC Characteristics on page 41](#) represents the active current specification for the write mode. [Section 17. AC Characteristics on page 45](#) contains timing specification tables and timing diagrams for write operations.

8.3.1 Accelerated Program Operation

The device offers accelerated program operations through the ACC function. This is one of two functions provided by the WP#/ACC pin. This function is primarily intended to allow faster manufacturing throughput at the factory.

If the system asserts V_{HH} on this pin, the device automatically enters the aforementioned Unlock Bypass mode, temporarily unprotects any protected sectors, and uses the higher voltage on the pin to reduce the time required for program operations. The system would use a two-cycle program command sequence as required by the Unlock Bypass mode. Removing V_{HH} from the WP#/ACC pin returns the device to normal operation. Note that V_{HH} must not be asserted on WP#/ACC for operations other than accelerated programming, or device damage may result. In addition, the WP#/ACC pin must not be left floating or unconnected; inconsistent behavior of the device may result. See [Write Protect \(WP#\) on page 19](#) for related information.

8.3.2 Autoselect Functions

If the system writes the autoselect command sequence, the device enters the autoselect mode. The system can then read autoselect codes from the internal register (which is separate from the memory array) on DQ15–DQ0. Standard read cycle timings apply in this mode. Refer to [Autoselect Mode on page 17](#) and [Autoselect Command Sequence on page 28](#) for more information.

8.4 Simultaneous Read/Write Operations with Zero Latency

This device is capable of reading data from one bank of memory while programming or erasing in another bank of memory. An erase operation may also be suspended to read from or program to another location within the same bank (except the sector being erased). [Figure 23 on page 50](#) shows how read and write cycles may be initiated for simultaneous operation with zero latency. I_{CC6} and I_{CC7} in the [Section 14. DC Characteristics on page 41](#) represent the current specifications for read-while-program and read-while-erase, respectively.

8.5 Standby Mode

When the system is not reading or writing to the device, it can place the device in the standby mode. In this mode, current consumption is greatly reduced, and the outputs are placed in the high impedance state, independent of the OE# input.

The device enters the CMOS standby mode when the CE# and RESET# pins are both held at $V_{CC} \pm 0.3V$. (Note that this is a more restricted voltage range than V_{IH} .) If CE# and RESET# are held at V_{IH} , but not within $V_{CC} \pm 0.3V$, the device will be in the standby mode, but the standby current will be greater. The device requires standard access time (t_{CE}) for read access when the device is in either of these standby modes, before it is ready to read data.

If the device is deselected during erasure or programming, the device draws active current until the operation is completed.

I_{CC3} in [Section 14. DC Characteristics on page 41](#) represents the standby current specification.

8.6 Automatic Sleep Mode

The automatic sleep mode minimizes Flash device energy consumption. The device automatically enables this mode when addresses remain stable for $t_{ACC} + 30$ ns. The automatic sleep mode is independent of the CE#, WE#, and OE# control signals. Standard address access timings provide new data when addresses are changed. While in sleep mode, output data is latched and always available to the system. I_{CC5} in [Section 14. DC Characteristics on page 41](#) represents the automatic sleep mode current specification.

8.7 RESET#: Hardware Reset Pin

The RESET# pin provides a hardware method of resetting the device to reading array data. When the RESET# pin is driven low for at least a period of t_{RP} , the device immediately terminates any operation in progress, tristates all output pins, and ignores all read/write commands for the duration of the RESET# pulse. The device also resets the internal state machine to reading array data. The operation that was interrupted should be reinitiated once the device is ready to accept another command sequence, to ensure data integrity.

Current is reduced for the duration of the RESET# pulse. When RESET# is held at $V_{SS} \pm 0.3V$, the device draws CMOS standby current (I_{CC4}). If RESET# is held at V_{IL} but not within $V_{SS} \pm 0.3V$, the standby current will be greater.

The RESET# pin may be tied to the system reset circuitry. A system reset would thus also reset the Flash memory, enabling the system to read the boot-up firmware from the Flash memory.

If RESET# is asserted during a program or erase operation, the RY/BY# pin remains a "0" (busy) until the internal reset operation is complete, which requires a time of t_{READY} (during Embedded Algorithms). The system can thus monitor RY/BY# to determine whether the reset operation is complete. If RESET# is asserted when a program or erase operation is not executing (RY/BY# pin is "1"), the reset operation is completed within a time of t_{READY} (not during Embedded Algorithms). The system can read data t_{RH} after the RESET# pin returns to V_{IH} .

Refer to [Section 17.2 Hardware Reset \(RESET#\) on page 46](#) for RESET# parameters and to [Figure 17 on page 46](#) for the timing diagram.

8.8 Output Disable Mode

When the OE# input is at V_{IH} , output from the device is disabled. The output pins are placed in the high impedance state.

Table 3. S29JL064J Sector Architecture

Bank	Sector	Sector Address A21-A12	Sector Size (KB/keywords)	(x8) Address Range	(x16) Address Range
Bank 1	SA0	0000000000	8/4	000000h–001FFFh	00000h–00FFFh
	SA1	0000000001	8/4	002000h–003FFFh	01000h–01FFFh
	SA2	0000000010	8/4	004000h–005FFFh	02000h–02FFFh
	SA3	0000000011	8/4	006000h–007FFFh	03000h–03FFFh
	SA4	0000000100	8/4	008000h–009FFFh	04000h–04FFFh
	SA5	0000000101	8/4	00A000h–00BFFFh	05000h–05FFFh
	SA6	0000000110	8/4	00C000h–00DFFFh	06000h–06FFFh
	SA7	0000000111	8/4	00E000h–00FFFFh	07000h–07FFFh
	SA8	0000001xxx	64/32	010000h–01FFFFh	08000h–0FFFFh
	SA9	0000010xxx	64/32	020000h–02FFFFh	10000h–17FFFh
	SA10	0000011xxx	64/32	030000h–03FFFFh	18000h–1FFFFh
	SA11	0000100xxx	64/32	040000h–04FFFFh	20000h–27FFFh
	SA12	0000101xxx	64/32	050000h–05FFFFh	28000h–2FFFFh
	SA13	0000110xxx	64/32	060000h–06FFFFh	30000h–37FFFh
	SA14	0000111xxx	64/32	070000h–07FFFFh	38000h–3FFFFh
	SA15	0001000xxx	64/32	080000h–08FFFFh	40000h–47FFFh
	SA16	0001001xxx	64/32	090000h–09FFFFh	48000h–4FFFFh
	SA17	0001010xxx	64/32	0A0000h–0AFFFFh	50000h–57FFFh
	SA18	0001011xxx	64/32	0B0000h–0BFFFFh	58000h–5FFFFh
	SA19	0001100xxx	64/32	0C0000h–0CFFFFh	60000h–67FFFh
	SA20	0001101xxx	64/32	0D0000h–0DFFFFh	68000h–6FFFFh
	SA21	0001110xxx	64/32	0E0000h–0EFFFFh	70000h–77FFFh
SA22	0001111xxx	64/32	0F0000h–0FFFFFh	78000h–7FFFFh	
Bank 2	SA23	0010000xxx	64/32	100000h–10FFFFh	80000h–87FFFh
	SA24	0010001xxx	64/32	110000h–11FFFFh	88000h–8FFFFh
	SA25	0010010xxx	64/32	120000h–12FFFFh	90000h–97FFFh
	SA26	0010011xxx	64/32	130000h–13FFFFh	98000h–9FFFFh
	SA27	0010100xxx	64/32	140000h–14FFFFh	A0000h–A7FFFh
	SA28	0010101xxx	64/32	150000h–15FFFFh	A8000h–AFFFFh
	SA29	0010110xxx	64/32	160000h–16FFFFh	B0000h–B7FFFh
	SA30	0010111xxx	64/32	170000h–17FFFFh	B8000h–BFFFFh
	SA31	0011000xxx	64/32	180000h–18FFFFh	C0000h–C7FFFh
	SA32	0011001xxx	64/32	190000h–19FFFFh	C8000h–CFFFFh
	SA33	0011010xxx	64/32	1A0000h–1AFFFFh	D0000h–D7FFFh
	SA34	0011011xxx	64/32	1B0000h–1BFFFFh	D8000h–DFFFFh
	SA35	0011000xxx	64/32	1C0000h–1CFFFFh	E0000h–E7FFFh
	SA36	0011101xxx	64/32	1D0000h–1DFFFFh	E8000h–EFFFFh
	SA37	0011110xxx	64/32	1E0000h–1EFFFFh	F0000h–F7FFFh

Note

5. The address range is A21:A-1 in byte mode (BYTE# = V_{IL}) or A21:A0 in word mode (BYTE# = V_{IH}).

Table 3. S29JL064J Sector Architecture (Continued)

Bank	Sector	Sector Address A21-A12	Sector Size (KB/keywords)	(x8) Address Range	(x16) Address Range
Bank 2	SA38	0011111xxx	64/32	1F0000h-1FFFFFFh	F8000h-FFFFFFh
	SA39	0100000xxx	64/32	200000h-20FFFFFFh	100000h-107FFFh
	SA40	0100001xxx	64/32	210000h-21FFFFFFh	108000h-10FFFFFFh
	SA41	0100010xxx	64/32	220000h-22FFFFFFh	110000h-117FFFh
	SA42	0101011xxx	64/32	230000h-23FFFFFFh	118000h-11FFFFFFh
	SA43	0100100xxx	64/32	240000h-24FFFFFFh	120000h-127FFFh
	SA44	0100101xxx	64/32	250000h-25FFFFFFh	128000h-12FFFFFFh
	SA45	0100110xxx	64/32	260000h-26FFFFFFh	130000h-137FFFh
	SA46	0100111xxx	64/32	270000h-27FFFFFFh	138000h-13FFFFFFh
	SA47	0101000xxx	64/32	280000h-28FFFFFFh	140000h-147FFFh
	SA48	0101001xxx	64/32	290000h-29FFFFFFh	148000h-14FFFFFFh
	SA49	0101010xxx	64/32	2A0000h-2AFFFFFFh	150000h-157FFFh
	SA50	0101011xxx	64/32	2B0000h-2BFFFFFFh	158000h-15FFFFFFh
	SA51	0101100xxx	64/32	2C0000h-2CFFFFFFh	160000h-167FFFh
	SA52	0101101xxx	64/32	2D0000h-2DFFFFFFh	168000h-16FFFFFFh
	SA53	0101110xxx	64/32	2E0000h-2EFFFFFFh	170000h-177FFFh
	SA54	0101111xxx	64/32	2F0000h-2FFFFFFFh	178000h-17FFFFFFh
	SA55	0110000xxx	64/32	300000h-30FFFFFFh	180000h-187FFFh
	SA56	0110001xxx	64/32	310000h-31FFFFFFh	188000h-18FFFFFFh
	SA57	0110010xxx	64/32	320000h-32FFFFFFh	190000h-197FFFh
	SA58	0110011xxx	64/32	330000h-33FFFFFFh	198000h-19FFFFFFh
	SA59	0110100xxx	64/32	340000h-34FFFFFFh	1A0000h-1A7FFFh
	SA60	0110101xxx	64/32	350000h-35FFFFFFh	1A8000h-1AFFFFFFh
	SA61	0110110xxx	64/32	360000h-36FFFFFFh	1B0000h-1B7FFFh
	SA62	0110111xxx	64/32	370000h-37FFFFFFh	1B8000h-1BFFFFFFh
	SA63	0111000xxx	64/32	380000h-38FFFFFFh	1C0000h-1C7FFFh
	SA64	0111001xxx	64/32	390000h-39FFFFFFh	1C8000h-1CFFFFFFh
	SA65	0111010xxx	64/32	3A0000h-3AFFFFFFh	1D0000h-1D7FFFh
	SA66	0111011xxx	64/32	3B0000h-3BFFFFFFh	1D8000h-1DFFFFFFh
	SA67	0111100xxx	64/32	3C0000h-3CFFFFFFh	1E0000h-1E7FFFh
SA68	0111101xxx	64/32	3D0000h-3DFFFFFFh	1E8000h-1EFFFFFFh	
SA69	0111110xxx	64/32	3E0000h-3EFFFFFFh	1F0000h-1F7FFFh	
SA70	0111111xxx	64/32	3F0000h-3FFFFFFFh	1F8000h-1FFFFFFFh	
Bank 3	SA71	1000000xxx	64/32	400000h-40FFFFFFh	200000h-207FFFh
	SA72	1000001xxx	64/32	410000h-41FFFFFFh	208000h-20FFFFFFh
	SA73	1000010xxx	64/32	420000h-42FFFFFFh	210000h-217FFFh
	SA74	1000011xxx	64/32	430000h-43FFFFFFh	218000h-21FFFFFFh
	SA75	1000100xxx	64/32	440000h-44FFFFFFh	220000h-227FFFh
	SA76	1000101xxx	64/32	450000h-45FFFFFFh	228000h-22FFFFFFh
	SA77	1000110xxx	64/32	460000h-46FFFFFFh	230000h-237FFFh

Note

5. The address range is A21:A-1 in byte mode (BYTE# = V_{IL}) or A21:A0 in word mode (BYTE# = V_{IH}).

Table 3. S29JL064J Sector Architecture (Continued)

Bank	Sector	Sector Address A21-A12	Sector Size (KB/keywords)	(x8) Address Range	(x16) Address Range
Bank 3	SA78	1000111xxx	64/32	470000h-47FFFFh	238000h-23FFFFh
	SA79	1001000xxx	64/32	480000h-48FFFFh	240000h-247FFFh
	SA80	1001001xxx	64/32	490000h-49FFFFh	248000h-24FFFFh
	SA81	1001010xxx	64/32	4A0000h-4AFFFFh	250000h-257FFFh
	SA82	1001011xxx	64/32	4B0000h-4BFFFFh	258000h-25FFFFh
	SA83	1001100xxx	64/32	4C0000h-4CFFFFh	260000h-267FFFh
	SA84	1001101xxx	64/32	4D0000h-4DFFFFh	268000h-26FFFFh
	SA85	1001110xxx	64/32	4E0000h-4EFFFFh	270000h-277FFFh
	SA86	1001111xxx	64/32	4F0000h-4FFFFFh	278000h-27FFFFh
	SA87	1010000xxx	64/32	500000h-50FFFFh	280000h-28FFFFh
	SA88	1010001xxx	64/32	510000h-51FFFFh	288000h-28FFFFh
	SA89	1010010xxx	64/32	520000h-52FFFFh	290000h-297FFFh
	SA90	1010011xxx	64/32	530000h-53FFFFh	298000h-29FFFFh
	SA91	1010100xxx	64/32	540000h-54FFFFh	2A0000h-2A7FFFh
	SA92	1010101xxx	64/32	550000h-55FFFFh	2A8000h-2AFFFFh
	SA93	1010110xxx	64/32	560000h-56FFFFh	2B0000h-2B7FFFh
	SA94	1010111xxx	64/32	570000h-57FFFFh	2B8000h-2BFFFFh
	SA95	1011000xxx	64/32	580000h-58FFFFh	2C0000h-2C7FFFh
	SA96	1011001xxx	64/32	590000h-59FFFFh	2C8000h-2CFFFFh
	SA97	1011010xxx	64/32	5A0000h-5AFFFFh	2D0000h-2D7FFFh
	SA98	1011011xxx	64/32	5B0000h-5BFFFFh	2D8000h-2DFFFFh
	SA99	1011100xxx	64/32	5C0000h-5CFFFFh	2E0000h-2E7FFFh
	SA100	1011101xxx	64/32	5D0000h-5DFFFFh	2E8000h-2EFFFFh
	SA101	1011110xxx	64/32	5E0000h-5EFFFFh	2F0000h-2FFFFFh
	SA102	1011111xxx	64/32	5F0000h-5FFFFFh	2F8000h-2FFFFFh
	SA103	1100000xxx	64/32	600000h-60FFFFh	300000h-307FFFh
	SA104	1100001xxx	64/32	610000h-61FFFFh	308000h-30FFFFh
	SA105	1100010xxx	64/32	620000h-62FFFFh	310000h-317FFFh
	SA106	1100011xxx	64/32	630000h-63FFFFh	318000h-31FFFFh
	SA107	1100100xxx	64/32	640000h-64FFFFh	320000h-327FFFh
	SA108	1100101xxx	64/32	650000h-65FFFFh	328000h-32FFFFh
	SA109	1100110xxx	64/32	660000h-66FFFFh	330000h-337FFFh
	SA110	1100111xxx	64/32	670000h-67FFFFh	338000h-33FFFFh
	SA111	1101000xxx	64/32	680000h-68FFFFh	340000h-347FFFh
SA112	1101001xxx	64/32	690000h-69FFFFh	348000h-34FFFFh	
SA113	1101010xxx	64/32	6A0000h-6AFFFFh	350000h-357FFFh	
SA114	1101011xxx	64/32	6B0000h-6BFFFFh	358000h-35FFFFh	
SA115	1101100xxx	64/32	6C0000h-6CFFFFh	360000h-367FFFh	
SA116	1101101xxx	64/32	6D0000h-6DFFFFh	368000h-36FFFFh	
SA117	1101110xxx	64/32	6E0000h-6EFFFFh	370000h-377FFFh	

Note

5. The address range is A21:A-1 in byte mode (BYTE# = V_{IL}) or A21:A0 in word mode (BYTE# = V_{IH}).

Table 3. S29JL064J Sector Architecture (Continued)

Bank	Sector	Sector Address A21–A12	Sector Size (KB/keywords)	(x8) Address Range	(x16) Address Range
Bank 3	SA118	1101111xxx	64/32	6F0000h–6FFFFFFh	378000h–37FFFFh
Bank 4	SA119	1110000xxx	64/32	700000h–70FFFFh	380000h–387FFFh
	SA120	1110001xxx	64/32	710000h–71FFFFh	388000h–38FFFFh
	SA121	1110010xxx	64/32	720000h–72FFFFh	390000h–397FFFh
	SA122	1110011xxx	64/32	730000h–73FFFFh	398000h–39FFFFh
	SA123	1110100xxx	64/32	740000h–74FFFFh	3A0000h–3A7FFFh
	SA124	1110101xxx	64/32	750000h–75FFFFh	3A8000h–3AFFFFh
	SA125	1110110xxx	64/32	760000h–76FFFFh	3B0000h–3B7FFFh
	SA126	1110111xxx	64/32	770000h–77FFFFh	3B8000h–3BFFFFh
	SA127	1111000xxx	64/32	780000h–78FFFFh	3C0000h–3C7FFFh
	SA128	1111001xxx	64/32	790000h–79FFFFh	3C8000h–3CFFFFh
	SA129	1111010xxx	64/32	7A0000h–7AFFFFh	3D0000h–3D7FFFh
	SA130	1111011xxx	64/32	7B0000h–7BFFFFh	3D8000h–3DFFFFh
	SA131	1111100xxx	64/32	7C0000h–7CFFFFh	3E0000h–3E7FFFh
	SA132	1111101xxx	64/32	7D0000h–7DFFFFh	3E8000h–3EFFFFh
	SA133	1111110xxx	64/32	7E0000h–7EFFFFh	3F0000h–3F7FFFh
	SA134	1111111000	8/4	7F0000h–7F1FFFh	3F8000h–3F8FFFh
	SA135	1111111001	8/4	7F2000h–7F3FFFh	3F9000h–3F9FFFh
	SA136	1111111010	8/4	7F4000h–7F5FFFh	3FA000h–3FAFFFh
SA137	1111111011	8/4	7F6000h–7F7FFFh	3FB000h–3FBFFFh	
SA138	1111111100	8/4	7F8000h–7F9FFFh	3FC000h–3FCFFFh	
SA139	1111111101	8/4	7FA000h–7FBFFFh	3FD000h–3FDFFFh	
SA140	1111111110	8/4	7FC000h–7FDFFFh	3FE000h–3FEFFFh	
SA141	1111111111	8/4	7FE000h–7FFFFFFh	3FF000h–3FFFFFFh	

Note

5. The address range is A21:A-1 in byte mode (BYTE# = V_{IL}) or A21:A0 in word mode (BYTE# = V_{IH}).

Table 4. Bank Address

Bank	A21–A19
1	000
2	001, 010, 011
3	100, 101, 110
4	111

Table 5. Secured Silicon Region Addresses

Device	Sector Size	(x8) Address Range	(x16) Address Range
S29JL064J	256 bytes	000000h–0000FFh	000000h–00007Fh

8.9 Autoselect Mode

The autoselect mode provides manufacturer and device identification, and sector protection verification, through identifier codes output on DQ7–DQ0. This mode is primarily intended for programming equipment to automatically match a device to be programmed with its corresponding programming algorithm. However, the autoselect codes can also be accessed in-system through the command register.

When using programming equipment, the autoselect mode requires V_{ID} on address pin A9. Address pins must be as shown in Table . In addition, when verifying sector protection, the sector address must appear on the appropriate highest order address bits (see Table 4 on page 16). Table shows the remaining address bits that are don't care. When all necessary bits have been set as required, the programming equipment may then read the corresponding identifier code on DQ7–DQ0. However, the autoselect codes can also be accessed in-system through the command register, for instances when the S29JL064J is erased or programmed in a system without access to high voltage on the A9 pin. The command sequence is illustrated in Table 12 on page 32. *Note that if a Bank Address (BA) on address bits A21, A20, and A19 is asserted during the third write cycle of the autoselect command, the host system can read autoselect data from that bank and then immediately read array data from another bank, without exiting the autoselect mode.*

To access the autoselect codes in-system, the host system can issue the autoselect command via the command register, as shown in Table 12 on page 32. This method does not require V_{ID} . Refer to Section 10.3 Autoselect Command Sequence on page 28 for more information.

S29JL064J Autoselect Codes, (High Voltage Method)

Description	CE#	OE#	WE#	A21 to A12	A11 to A10	A9	A8 to A7	A6	A5 to A4	A3	A2	A1	A0	DQ15 to DQ8		DQ7 to DQ0			
														BYTE# = V_{IH}	BYTE# = V_{IL}				
Manufacturer ID: Cypress Products	L	L	H	BA	X	V_{ID}	X	L	X	L	L	L	L	X	X	01h			
Device ID	Read Cycle 1	L	L	H	BA	X	V_{ID}	X	L	X	L	L	L	H	X	22h	7Eh		
	Read Cycle 2										H	H	H	L				22h	02h
	Read Cycle 3										H	H	H	H				22h	01h
Sector Protection Verification	L	L	H	SA	X	V_{ID}	X	L	X	L	L	H	L	X	X	01h (protected), 00h (unprotected)			
Secured Silicon Indicator Bit (DQ6, DQ7)	L	L	H	BA	X	V_{ID}	X	L	X	L	L	H	H	X	X	81h (Factory Locked), 41h (Customer Locked), 01h (Not Locked)			

Legend

L = Logic Low = V_{IL}
H = Logic High = V_{IH}
BA = Bank Address
SA = Sector Address
X = Don't care.

8.10 Boot Sector/Sector Block Protection and Unprotection

Note: For the following discussion, the term *sector* applies to both boot sectors and sector blocks. A sector block consists of two or more adjacent sectors that are protected or unprotected at the same time (see Table 6).

The hardware sector protection feature disables both program and erase operations in any sector. The hardware sector unprotection feature re-enables both program and erase operations in previously protected sectors. Sector protection/unprotection can be implemented via two methods.

Table 6. S29JL064J Boot Sector/Sector Block Addresses for Protection/Unprotection

Sector	A21–A12	Sector/Sector Block Size
SA0	000000000	8 KB
SA1	000000001	8 KB
SA2	000000010	8 KB
SA3	000000011	8 KB
SA4	000000100	8 KB
SA5	000000101	8 KB
SA6	000000110	8 KB
SA7	000000111	8 KB
SA8–SA10	000001XXX, 000010XXX, 0000011XXX,	192 (3x64) KB
SA11–SA14	00001XXXXX	256 (4x64) KB
SA15–SA18	00010XXXXX	256 (4x64) KB
SA19–SA22	00011XXXXX	256 (4x64) KB
SA23–SA26	00100XXXXX	256 (4x64) KB
SA27–SA30	00101XXXXX	256 (4x64) KB
SA31–SA34	00110XXXXX	256 (4x64) KB
SA35–SA38	00111XXXXX	256 (4x64) KB
SA39–SA42	01000XXXXX	256 (4x64) KB
SA43–SA46	01001XXXXX	256 (4x64) KB
SA47–SA50	01010XXXXX	256 (4x64) KB
SA51–SA54	01011XXXXX	256 (4x64) KB
SA55–SA58	01100XXXXX	256 (4x64) KB
SA59–SA62	01101XXXXX	256 (4x64) KB
SA63–SA66	01110XXXXX	256 (4x64) KB
SA67–SA70	01111XXXXX	256 (4x64) KB
SA71–SA74	10000XXXXX	256 (4x64) KB
SA75–SA78	10001XXXXX	256 (4x64) KB
SA79–SA82	10010XXXXX	256 (4x64) KB
SA83–SA86	10011XXXXX	256 (4x64) KB
SA87–SA90	10100XXXXX	256 (4x64) KB
SA91–SA94	10101XXXXX	256 (4x64) KB
SA95–SA98	10110XXXXX	256 (4x64) KB
SA99–SA102	10111XXXXX	256 (4x64) KB
SA103–SA106	11000XXXXX	256 (4x64) KB
SA107–SA110	11001XXXXX	256 (4x64) KB
SA111–SA114	11010XXXXX	256 (4x64) KB
SA115–SA118	11011XXXXX	256 (4x64) KB

Table 6. S29JL064J Boot Sector/Sector Block Addresses for Protection/Unprotection (Continued)

Sector	A21–A12	Sector/Sector Block Size
SA119–SA122	11100XXXXX	256 (4x64) KB
SA123–SA126	11101XXXXX	256 (4x64) KB
SA127–SA130	11110XXXXX	256 (4x64) KB
SA131–SA133	1111100XXX, 1111101XXX, 1111110XXX	192 (3x64) KB
SA134	1111111000	8 KB
SA135	1111111001	8 KB
SA136	1111111010	8 KB
SA137	1111111011	8 KB
SA138	1111111100	8 KB
SA139	1111111101	8 KB
SA140	1111111110	8 KB
SA141	1111111111	8 KB

Sector Protect/Sector Unprotect requires V_{ID} on the RESET# pin only, and can be implemented either in-system or via programming equipment. [Figure 4 on page 21](#) shows the algorithms and [Figure 28 on page 53](#) shows the timing diagram. For sector unprotect, all unprotected sectors must first be protected prior to the first sector unprotect write cycle. *Note that the sector unprotect algorithm unprotects all sectors in parallel. All previously protected sectors must be individually re-protected.* To change data in protected sectors efficiently, the temporary sector unprotect function is available. See [Section 8.12 Temporary Sector Unprotect on page 20](#).

The device is shipped with all sectors unprotected. Optional Cypress programming service enable programming and protecting sectors at the factory prior to shipping the device. Contact your local sales office for details.

It is possible to determine whether a sector is protected or unprotected. See [Section 8.9 Autoselect Mode on page 17](#) for details.

8.11 Write Protect (WP#)

The Write Protect function provides a hardware method of protecting without using V_{ID} . This function is one of two provided by the WP#/ACC pin.

If the system asserts V_{IL} on the WP#/ACC pin, the device disables program and erase functions in sectors 0, 1, 140, and 141, independently of whether those sectors were protected or unprotected using the method described in [Section 8.10 Boot Sector/Sector Block Protection and Unprotection on page 18](#).

If the system asserts V_{IH} on the WP#/ACC pin, the device reverts to whether sectors 0, 1, 140, and 141 were last set to be protected or unprotected. That is, sector protection or unprotection for these sectors depends on whether they were last protected or unprotected using the method described in [Section 8.10 Boot Sector/Sector Block Protection and Unprotection on page 18](#).

Note that the WP#/ACC pin must not be left floating or unconnected; inconsistent behavior of the device may result.

Table 7. WP#/ACC Modes

WP# Input Voltage	Device Mode
V_{IL}	Disables programming and erasing in SA0, SA1, SA140, and SA141
V_{IH}	Enables programming and erasing in SA0, SA1, SA140, and SA141, dependent on whether they were last protected or unprotected.
V_{HH}	Enables accelerated programming (ACC). See Section 8.3.1 Accelerated Program Operation on page 11 .

8.12 Temporary Sector Unprotect

Note: For the following discussion, the term *sector* applies to both sectors and sector blocks. A sector block consists of two or more adjacent sectors that are protected or unprotected at the same time (see [Table 6 on page 18](#)).

This feature allows temporary unprotection of previously protected sectors to change data in-system. The Temporary Sector Unprotect mode is activated by setting the RESET# pin to V_{ID} . During this mode, formerly protected sectors can be programmed or erased by selecting the sector addresses. Once V_{ID} is removed from the RESET# pin, all the previously protected sectors are protected again. [Figure 3](#) shows the algorithm, and [Figure 27 on page 52](#) shows the timing diagrams, for this feature. If the WP#/ACC pin is at V_{IL} , sectors 0, 1, 140, and 141 will remain protected during the Temporary sector Unprotect mode.

Figure 3. Temporary Sector Unprotect Operation

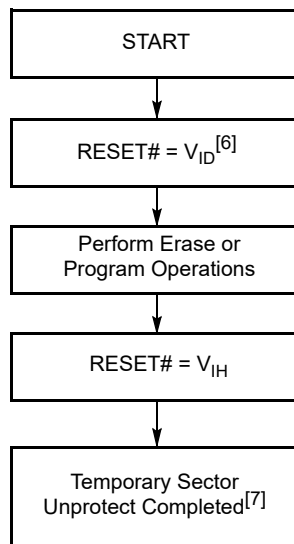

Notes

- 6. All protected sectors unprotected (If WP#/ACC = V_{IL} , sectors 0, 1, 140, and 141 will remain protected).
- 7. All previously protected sectors are protected once again.

Figure 4. In-System Sector Protect/Unprotect Algorithms

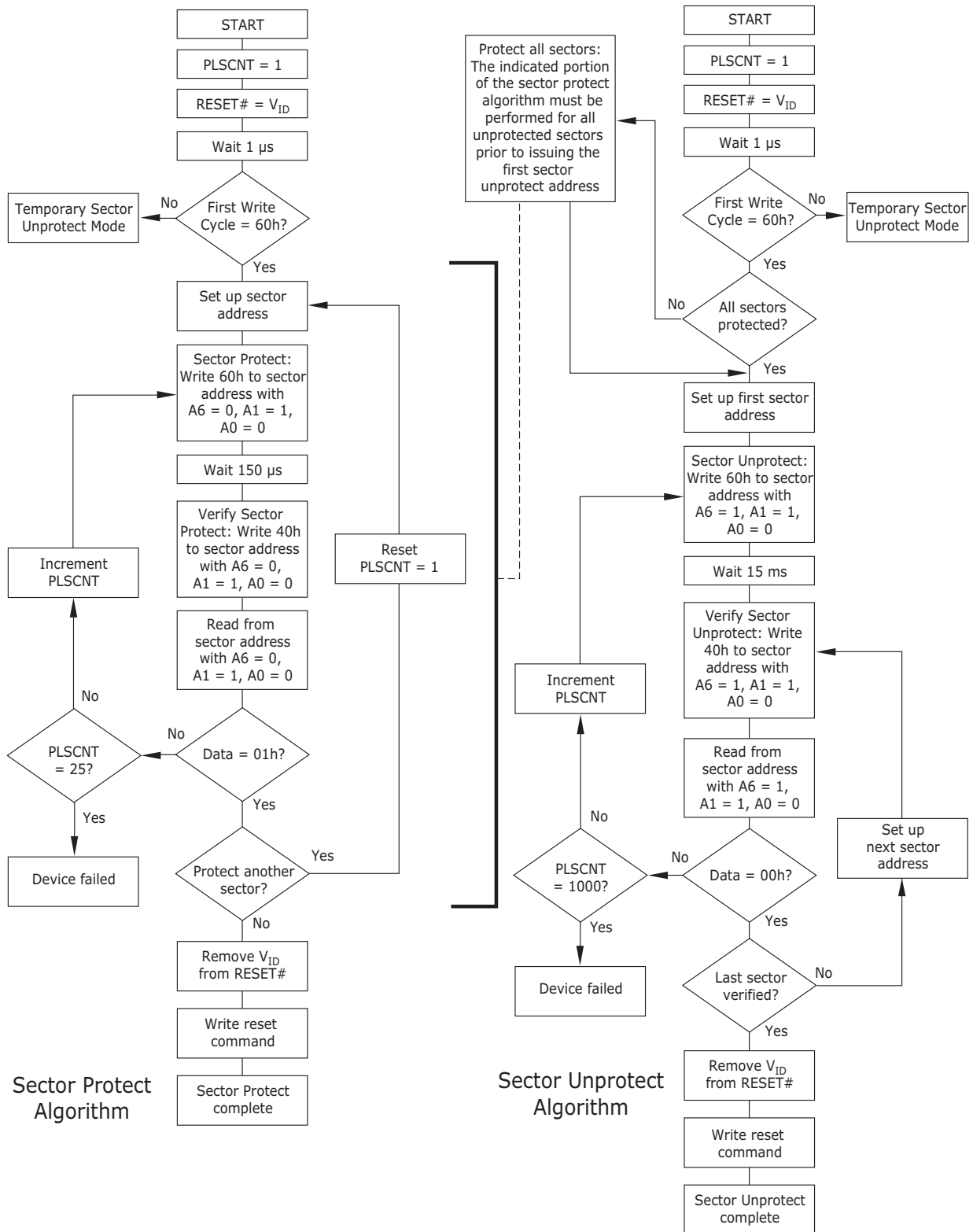

8.13 Secured Silicon Region

The Secured Silicon Region feature provides a Flash memory region that enables permanent part identification through an Electronic Serial Number (ESN). The Secured Silicon Region is 256 bytes in length, and may be shipped unprotected, allowing customers to utilize that sector in any manner they choose, or may be shipped locked at the factory (upon customer request). The Secured Silicon Indicator Bit data will be 81h if factory locked, 41h if customer locked, or 01h if neither. Refer to [Table on page 17](#) for more details.

The system accesses the Secured Silicon Region through a command sequence (see [Section 10.4 Enter Secured Silicon Region/Exit Secured Silicon Region Command Sequence on page 28](#)). After the system has written the Enter Secured Silicon Region command sequence, it may read the Secured Silicon Region by using the addresses normally occupied by the boot sectors. This mode of operation continues until the system issues the Exit Secured Silicon Region command sequence, or until power is removed from the device. On power-up, or following a hardware reset, the device reverts to sending commands to the first 256 bytes of Sector 0. *Note that the ACC function and unlock bypass modes are not available when the Secured Silicon Region is enabled.*

8.13.1 Factory Locked: Secured Silicon Region Programmed and Protected At the Factory

In a factory locked device, the Secured Silicon Region is protected when the device is shipped from the factory. The Secured Silicon Region cannot be modified in any way. The device is preprogrammed with both a random number and a secure ESN. The 8-word random number is at addresses 000000h–000007h in word mode (or 000000h–00000Fh in byte mode). The secure ESN is programmed in the next 8 words at addresses 000008h–00000Fh (or 000010h–00001Fh in byte mode). The device is available preprogrammed with one of the following:

- A random, secure ESN only
- Customer code through Cypress programming services
- Both a random, secure ESN and customer code through Cypress programming services

Contact your local sales office for details on using Cypress programming services.

8.13.2 Customer Lockable: Secured Silicon Region NOT Programmed or Protected At the Factory

If the security feature is not required, the Secured Silicon Region can be treated as an additional Flash memory space. The Secured Silicon Region can be read any number of times, but can be programmed and locked only once. Note that the accelerated programming (ACC) and unlock bypass functions are not available when programming the Secured Silicon Region.

- Write the three-cycle Enter Secured Silicon Region command sequence, and then follow the in-system sector protect algorithm as shown in [Figure 4 on page 21](#), except that *RESET#* may be at either V_{IH} or V_{ID} . This allows in-system protection of the Secured Silicon Region without raising any device pin to a high voltage. Note that this method is only applicable to the Secured Silicon Region.
- To verify the protect/unprotect status of the Secured Silicon Region, follow the algorithm shown in [Figure 5 on page 23](#).

Once the Secured Silicon Region is locked and verified, the system must write the Exit Secured Silicon Region command sequence to return to reading and writing the remainder of the array.

The Secured Silicon Region lock must be used with caution since, once locked, there is no procedure available for unlocking the Secured Silicon Region and none of the bits in the Secured Silicon Region memory space can be modified in any way.

Figure 5. Secured Silicon Region Protect Verify

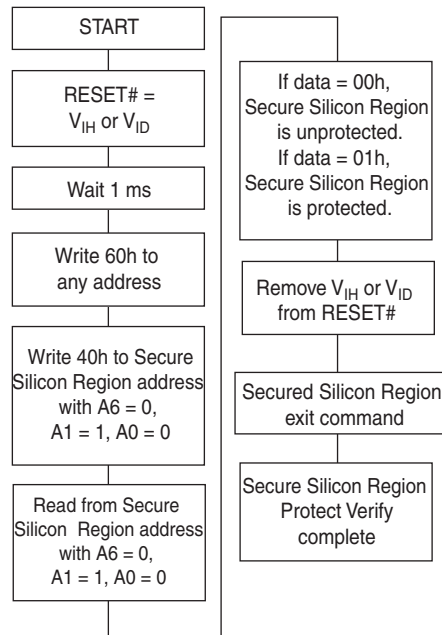

8.14 Hardware Data Protection

The command sequence requirement of unlock cycles for programming or erasing provides data protection against inadvertent writes (refer to Table 12 on page 32 for command definitions). In addition, the following hardware data protection measures prevent accidental erasure or programming, which might otherwise be caused by spurious system level signals during V_{CC} power-up and power-down transitions, or from system noise.

8.14.1 Low V_{CC} Write Inhibit

When V_{CC} is less than V_{LKO} , the device does not accept any write cycles. This protects data during V_{CC} power-up and power-down. The command register and all internal program/erase circuits are disabled, and the device resets to the read mode. Subsequent writes are ignored until V_{CC} is greater than V_{LKO} . The system must provide the proper signals to the control pins to prevent unintentional writes when V_{CC} is greater than V_{LKO} .

8.14.2 Write Pulse Glitch Protection

Noise pulses of less than 5 ns (typical) on OE#, CE# or WE# do not initiate a write cycle.

8.14.3 Logical Inhibit

Write cycles are inhibited by holding any one of OE# = V_{IL} , CE# = V_{IH} or WE# = V_{IH} . To initiate a write cycle, CE# and WE# must be a logical zero while OE# is a logical one.

8.14.4 Power-Up Write Inhibit

If WE# = CE# = V_{IL} and OE# = V_{IH} during power up, the device does not accept commands on the rising edge of WE#. The internal state machine is automatically reset to the read mode on power-up.

9. Common Flash Memory Interface (CFI)

The Common Flash Interface (CFI) specification outlines device and host system software interrogation handshake, which allows specific vendor-specified software algorithms to be used for entire families of devices. Software support can then be device-independent, JEDEC ID-independent, and forward- and backward-compatible for the specified flash device families. Flash vendors can standardize their existing interfaces for long-term compatibility.

This device enters the CFI Query mode when the system writes the CFI Query command, 98h, to address 55h in word mode (or address AAh in byte mode), any time the device is ready to read array data. The system can read CFI information at the addresses given in [Table 8 on page 24](#) to [Table 11 on page 25](#). To terminate reading CFI data, the system must write the reset command. The CFI Query mode is not accessible when the device is executing an Embedded Program or embedded Erase algorithm.

The system can also write the CFI query command when the device is in the autoselect mode via the command register only (high voltage method does not apply). The device enters the CFI query mode, and the system can read CFI data at the addresses given in [Table 8 on page 24](#) to [Table 11 on page 25](#). The system must write the reset command to return to reading array data.

For further information, please refer to the CFI Specification and CFI Publication 100. Contact your local sales office for copies of these documents.

Table 8. CFI Query Identification String

Addresses (Word Mode)	Addresses (Byte Mode)	Data	Description
10h 11h 12h	20h 22h 24h	0051h 0052h 0059h	Query Unique ASCII string "QRY"
13h 14h	26h 28h	0002h 0000h	Primary OEM Command Set
15h 16h	2Ah 2Ch	0040h 0000h	Address for Primary Extended Table
17h 18h	2Eh 30h	0000h 0000h	Alternate OEM Command Set (00h = none exists)
19h 1Ah	32h 34h	0000h 0000h	Address for Alternate OEM Extended Table (00h = none exists)

Table 9. System Interface String

Addresses (Word Mode)	Addresses (Byte Mode)	Data	Description
1Bh	36h	0027h	V _{CC} Min. (write/erase) D7–D4: volt, D3–D0: 100 millivolt
1Ch	38h	0036h	V _{CC} Max. (write/erase) D7–D4: volt, D3–D0: 100 millivolt
1Dh	3Ah	0000h	V _{PP} Min. voltage (00h = no V _{PP} pin present)
1Eh	3Ch	0000h	V _{PP} Max. voltage (00h = no V _{PP} pin present)
1Fh	3Eh	0003h	Typical timeout per single byte/word write 2 ^N μs
20h	40h	0000h	Typical timeout for Min. size buffer write 2 ^N μs (00h = not supported)
21h	42h	0009h	Typical timeout per individual block erase 2 ^N ms
22h	44h	000Fh	Typical timeout for full chip erase 2 ^N ms (00h = not supported)
23h	46h	0004h	Max. timeout for byte/word write 2 ^N times typical
24h	48h	0000h	Max. timeout for buffer write 2 ^N times typical
25h	4Ah	0004h	Max. timeout per individual block erase 2 ^N times typical
26h	4Ch	0000h	Max. timeout for full chip erase 2 ^N times typical (00h = not supported)

Table 10. Device Geometry Definition

Addresses (Word Mode)	Addresses (Byte Mode)	Data	Description
27h	4Eh	0017h	Device Size = 2 ^N byte
28h 29h	50h 52h	0002h 0000h	Flash Device Interface description (refer to the CFI publication 100)
2Ah 2Bh	54h 56h	0000h 0000h	Max. number of byte in multi-byte write = 2 ^N (00h = not supported)
2Ch	58h	0003h	Number of Erase Block Regions within device
2Dh 2Eh 2Fh 30h	5Ah 5Ch 5Eh 60h	0007h 0000h 0020h 0000h	Erase Block Region 1 Information (refer to the CFI specification or CFI publication 100)
31h 32h 33h 34h	62h 64h 66h 68h	007Dh 0000h 0000h 0001h	Erase Block Region 2 Information (refer to the CFI specification or CFI publication 100)
35h 36h 37h 38h	6Ah 6Ch 6Eh 70h	0007h 0000h 0020h 0000h	Erase Block Region 3 Information (refer to the CFI specification or CFI publication 100)
39h 3Ah 3Bh 3Ch	72h 74h 76h 78h	0000h 0000h 0000h 0000h	Erase Block Region 4 Information (refer to the CFI specification or CFI publication 100)

Table 11. Primary Vendor-Specific Extended Query

Addresses (Word Mode)	Addresses (Byte Mode)	Data	Description
40h 41h 42h	80h 82h 84h	0050h 0052h 0049h	Query-unique ASCII string "PRI"
43h	86h	0031h	Major version number, ASCII (reflects modifications to the silicon)
44h	88h	0033h	Minor version number, ASCII (reflects modifications to the CFI table)
45h	8Ah	000Ch	Address Sensitive Unlock (Bits 1-0) 0 = Required, 1 = Not Required Process Technology (Bits 7-2) 0011 = 0.11 μm Floating Gate
46h	8Ch	0002h	Erase Suspend 0 = Not Supported, 1 = To Read Only, 2 = To Read & Write
47h	8Eh	0001h	Sector Protect 0 = Not Supported, X = Number of sectors per group
48h	90h	0001h	Sector Temporary Unprotect 00 = Not Supported, 01 = Supported

Table 11. Primary Vendor-Specific Extended Query (Continued)

Addresses (Word Mode)	Addresses (Byte Mode)	Data	Description
49h	92h	0004h	Sector Protect/Unprotect scheme 01 = 29F040 mode, 02 = 29F016 mode, 03 = 29F400, 04 = 29LV800 mode
4Ah	94h	0077h	Simultaneous Operation 00 = Not Supported, X = Number of Sectors (excluding Bank 1)
4Bh	96h	0000h	Burst Mode Type 00 = Not Supported, 01 = Supported
4Ch	98h	0000h	Page Mode Type 00 = Not Supported, 01 = 4 Word Page, 02 = 8 Word Page
4Dh	9Ah	0085h	ACC (Acceleration) Supply Minimum 00h = Not Supported, D7-D4: Volt, D3-D0: 100 mV
4Eh	9Ch	0095h	ACC (Acceleration) Supply Maximum 00h = Not Supported, D7-D4: Volt, D3-D0: 100 mV
4Fh	9Eh	0001h	Top/Bottom Boot Sector Flag 00h = Uniform device, 01h = 8 x 8 KB Sectors, Top And Bottom Boot with Write Protect, 02h = Bottom Boot Device, 03h = Top Boot Device, 04h = Both Top and Bottom
50h	A0h	0000h	Program Suspend 0 = Not supported, 1 = Supported
57h	A Eh	0004h	Bank Organization 00 = Data at 4Ah is zero, X = Number of Banks
58h	B0h	0017h	Bank 1 Region Information X = Number of Sectors in Bank 1
59h	B2h	0030h	Bank 2 Region Information X = Number of Sectors in Bank 2
5Ah	B4h	0030h	Bank 3 Region Information X = Number of Sectors in Bank 3
5Bh	B6h	0017h	Bank 4 Region Information X = Number of Sectors in Bank 4

10. Command Definitions

Writing specific address and data sequences into the command register initiates device operations. [Table 12 on page 32](#) defines the valid register command sequences. *Writing incorrect address and data values or writing them in the improper sequence may place the device in an unknown state. A reset command is then required to return the device to reading array data.*

All addresses are latched on the falling edge of WE# or CE#, whichever happens later. All data is latched on the rising edge of WE# or CE#, whichever happens first. Refer to [Section 17. AC Characteristics on page 45](#) for timing diagrams.

10.1 Reading Array Data

The device is automatically set to reading array data after device power-up. No commands are required to retrieve data. Each bank is ready to read array data after completing an Embedded Program or Embedded Erase algorithm.

After the device accepts an Erase Suspend command, the corresponding bank enters the erase-suspend-read mode, after which the system can read data from any non-erase-suspended sector within the same bank. The system can read array data using the standard read timing, except that if it reads at an address within erase-suspended sectors, the device outputs status data. After completing a programming operation in the Erase Suspend mode, the system may once again read array data with the same exception. See [Section 10.8 Erase Suspend/Erase Resume Commands on page 31](#) for more information.

The system *must* issue the reset command to return a bank to the read (or erase-suspend-read) mode if DQ5 goes high during an active program or erase operation, or if the bank is in the autoselect mode. See [Section 10.2 Reset Command on page 27](#) for more information.

See [Section 8.2 Requirements for Reading Array Data on page 11](#) for more information. [Section 17.1 Read-Only Operations on page 45](#) provides the read parameters, and [Figure 16 on page 45](#) shows the timing diagram.

10.2 Reset Command

Writing the reset command resets the banks to the read or erase-suspend-read mode. Address bits are don't cares for this command.

The reset command may be written between the sequence cycles in an erase command sequence before erasing begins. This resets the bank to which the system was writing to the read mode. Once erasure begins, however, the device ignores reset commands until the operation is complete.

The reset command may be written between the sequence cycles in a program command sequence before programming begins. This resets the bank to which the system was writing to the read mode. If the program command sequence is written to a bank that is in the Erase Suspend mode, writing the reset command returns that bank to the erase-suspend-read mode. Once programming begins, however, the device ignores reset commands until the operation is complete.

The reset command may be written between the sequence cycles in an autoselect command sequence. Once in the autoselect mode, the reset command must be written to return to the read mode. If a bank entered the autoselect mode while in the Erase Suspend mode, writing the reset command returns that bank to the erase-suspend-read mode.

If DQ5 goes high during a program or erase operation, writing the reset command returns the bank to the read mode (or erase-suspend-read mode if that bank was in Erase Suspend). Please note that the RY/BY# signal remains low until this reset is issued.

10.3 Autoselect Command Sequence

The autoselect command sequence allows the host system to access the manufacturer and device codes, and determine whether or not a sector is protected. The autoselect command sequence may be written to an address within a bank that is either in the read or erase-suspend-read mode. The autoselect command may not be written while the device is actively programming or erasing in another bank.

The autoselect command sequence is initiated by first writing two unlock cycles. This is followed by a third write cycle that contains the bank address and the autoselect command. The bank then enters the autoselect mode. The system may read any number of autoselect codes without re-initiating the command sequence.

[Table 12 on page 32](#) shows the address and data requirements. To determine sector protection information, the system must write to the appropriate bank address (BA) and sector address (SA). [Table 4 on page 16](#) shows the address range and bank number associated with each sector.

The system must write the reset command to return to the read mode (or erase-suspend-read mode if the bank was previously in Erase Suspend).

10.4 Enter Secured Silicon Region/Exit Secured Silicon Region Command Sequence

The system can access the Secured Silicon Region by issuing the three-cycle Enter Secured Silicon Region command sequence. The device continues to access the Secured Silicon Region until the system issues the four-cycle Exit Secured Silicon Region command sequence. The Exit Secured Silicon Region command sequence returns the device to normal operation. The Secured Silicon Region is not accessible when the device is executing an Embedded Program or embedded Erase algorithm. [Table 12 on page 32](#) shows the address and data requirements for both command sequences. See also [Section 8.13 Secured Silicon Region on page 22](#) for further information. *Note that the ACC function and unlock bypass modes are not available when the Secured Silicon Region is enabled.*

10.5 Byte/Word Program Command Sequence

The system may program the device by word or byte, depending on the state of the BYTE# pin. Programming is a four-bus-cycle operation. The program command sequence is initiated by writing two unlock write cycles, followed by the program set-up command. The program address and data are written next, which in turn initiate the Embedded Program algorithm. The system is *not* required to provide further controls or timings. The device automatically provides internally generated program pulses and verifies the programmed cell margin. [Table 12 on page 32](#) shows the address and data requirements for the byte program command sequence.

When the Embedded Program algorithm is complete, that bank then returns to the read mode and addresses are no longer latched. The system can determine the status of the program operation by using DQ7, DQ6, or RY/BY#. Refer to [Section 11. Write Operation Status on page 34](#) for information on these status bits.

Any commands written to the device during the Embedded Program Algorithm are ignored. Note that a **hardware reset** immediately terminates the program operation. The program command sequence should be reinitiated once that bank has returned to the read mode, to ensure data integrity. *Note that the Secured Silicon Region, autoselect, and CFI functions are unavailable when a program operation is in progress.*

Programming is allowed in any sequence and across sector boundaries. **A bit cannot be programmed from 0 back to a 1.** Attempting to do so may cause that bank to set DQ5 = 1, or cause the DQ7 and DQ6 status bits to indicate the operation was successful. However, a succeeding read will show that the data is still 0. Only erase operations can convert a 0 to a 1.

10.5.1 Unlock Bypass Command Sequence

The unlock bypass feature allows the system to program bytes or words to a bank faster than using the standard program command sequence. The unlock bypass command sequence is initiated by first writing two unlock cycles. This is followed by a third write cycle containing the unlock bypass command, 20h. That bank then enters the unlock bypass mode. A two-cycle unlock bypass program command sequence is all that is required to program in this mode. The first cycle in this sequence contains the unlock bypass program command, A0h; the second cycle contains the program address and data. Additional data is programmed in the same manner. This mode dispenses with the initial two unlock cycles required in the standard program command sequence, resulting in faster total programming time. [Table 12 on page 32](#) shows the requirements for the command sequence.

During the unlock bypass mode, only the Unlock Bypass Program and Unlock Bypass Reset commands are valid. To exit the unlock bypass mode, the system must issue the two-cycle unlock bypass reset command sequence. (See [Table 12 on page 32](#)).

The device offers accelerated program operations through the WP#/ACC pin. When the system asserts V_{HH} on the WP#/ACC pin, the device automatically enters the Unlock Bypass mode. The system may then write the two-cycle Unlock Bypass program command sequence. The device uses the higher voltage on the WP#/ACC pin to accelerate the operation. Note that the WP#/ACC pin must not be at V_{HH} for any operation other than accelerated programming, or device damage may result. In addition, the WP#/ACC pin must not be left floating or unconnected; inconsistent behavior of the device may result.

[Figure 6 on page 29](#) illustrates the algorithm for the program operation. Refer to [Section 17.4 Erase and Program Operations on page 48](#) for parameters, and [Figure 20 on page 49](#) for timing diagrams.

Figure 6. Program Operation^[8]

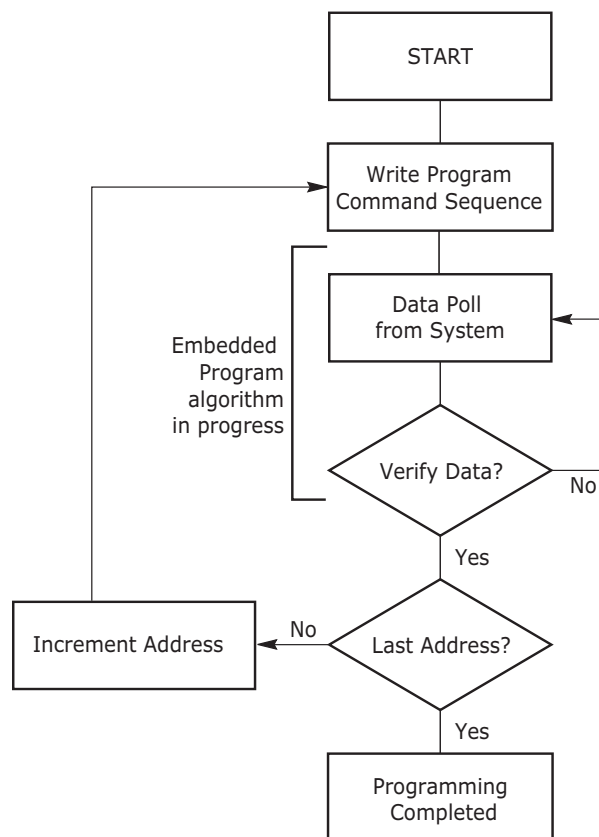

Note

8. See [Table 12 on page 32](#) for program command sequence.

10.6 Chip Erase Command Sequence

Chip erase is a six bus cycle operation. The chip erase command sequence is initiated by writing two unlock cycles, followed by a set-up command. Two additional unlock write cycles are then followed by the chip erase command, which in turn invokes the Embedded Erase algorithm. The device does *not* require the system to preprogram prior to erase. The Embedded Erase algorithm automatically preprograms and verifies the entire memory for an all zero data pattern prior to electrical erase. The system is not required to provide any controls or timings during these operations. [Table 12 on page 32](#) shows the address and data requirements for the chip erase command sequence.

When the Embedded Erase algorithm is complete, that bank returns to the read mode and addresses are no longer latched. The system can determine the status of the erase operation by using DQ7, DQ6, DQ2, or RY/BY#. Refer to [Section 11. Write Operation Status on page 34](#) for information on these status bits.

Any commands written during the chip erase operation are ignored. However, note that a **hardware reset** immediately terminates the erase operation. If that occurs, the chip erase command sequence should be reinitiated once that bank has returned to reading array data, to ensure data integrity. *Note that the Secured Silicon Region, autoselect, and CFI functions are unavailable when an erase operation is in progress.*

[Figure 7 on page 31](#) illustrates the algorithm for the erase operation. Refer to [Section 17.4 Erase and Program Operations on page 48](#) for parameters, and [Figure 22 on page 50](#) for timing diagrams.

10.7 Sector Erase Command Sequence

Sector erase is a six bus cycle operation. The sector erase command sequence is initiated by writing two unlock cycles, followed by a set-up command. Two additional unlock cycles are written, and are then followed by the address of the sector to be erased, and the sector erase command. [Table 12 on page 32](#) shows the address and data requirements for the sector erase command sequence.

The device does *not* require the system to preprogram prior to erase. The Embedded Erase algorithm automatically programs and verifies the entire sector for an all zero data pattern prior to electrical erase. The system is not required to provide any controls or timings during these operations.

After the command sequence is written, a sector erase time-out of 50 μ s occurs. During the time-out period, additional sector addresses and sector erase commands may be written. However, these additional erase commands are only one bus cycle long and should be identical to the sixth cycle of the standard erase command explained above. Loading the sector erase buffer may be done in any sequence, and the number of sectors may be from one sector to all sectors. The time between these additional cycles must be less than 50 μ s, otherwise erasure may begin. Any sector erase address and command following the exceeded time-out may or may not be accepted. It is recommended that processor interrupts be disabled during this time to ensure all commands are accepted. The interrupts can be re-enabled after the last Sector Erase command is written. **If any command other than 30h, B0h, F0h is input during the time-out period, the normal operation will not be guaranteed.** The system must rewrite the command sequence and any additional addresses and commands.

The system can monitor DQ3 to determine if the sector erase timer has timed out (See the section on DQ3: Sector Erase Timer.). The time-out begins from the rising edge of the final WE# or CE# pulse (first rising edge) in the command sequence.

When the Embedded Erase algorithm is complete, the bank returns to reading array data and addresses are no longer latched. Note that while the Embedded Erase operation is in progress, the system can read data from the non-erasing bank. The system can determine the status of the erase operation by reading DQ7, DQ6, DQ2, or RY/BY# in the erasing bank. Refer to [Section 11. Write Operation Status on page 34](#) for information on these status bits.

Once the sector erase operation has begun, only the Erase Suspend command is valid. All other commands are ignored. However, note that a **hardware reset** immediately terminates the erase operation. If that occurs, the sector erase command sequence should be reinitiated once that bank has returned to reading array data, to ensure data integrity. *Note that the Secured Silicon Region, autoselect, and CFI functions are unavailable when an erase operation is in progress.*

[Figure 7 on page 31](#) illustrates the algorithm for the erase operation. Refer to [Section 17.4 Erase and Program Operations on page 48](#) for parameters, and [Figure 22 on page 50](#) for timing diagrams.

Figure 7. Erase Operation^[9, 10]

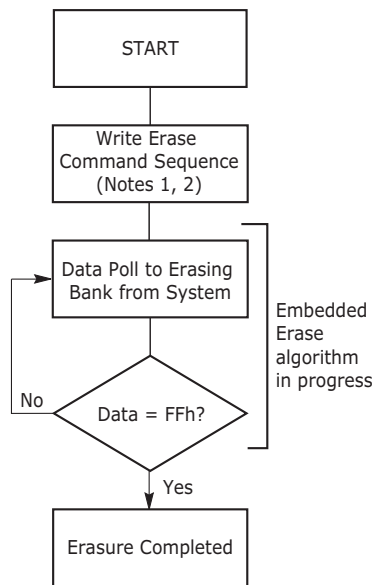

10.8 Erase Suspend/Erase Resume Commands

The Erase Suspend command, B0h, allows the system to interrupt a sector erase operation and then read data from, or program data to, any sector not selected for erasure. The bank address is required when writing this command. This command is valid only during the sector erase operation, including the 50 μ s time-out period during the sector erase command sequence. The Erase Suspend command is ignored if written during the chip erase operation or Embedded Program algorithm. The bank address must contain one of the sectors currently selected for erase.

When the Erase Suspend command is written during the sector erase operation, the device requires a maximum of 35 μ s to suspend the erase operation. However, when the Erase Suspend command is written during the sector erase time-out, the device immediately terminates the time-out period and suspends the erase operation.

After the erase operation has been suspended, the bank enters the erase-suspend-read mode. The system can read data from or program data to any sector not selected for erasure. (The device *erase suspends* all sectors selected for erasure.) It is not recommended to program the Secured Silicon Region after an erase suspend, as proper device functionality cannot be guaranteed. Reading at any address within erase-suspended sectors produces status information on DQ7–DQ0. The system can use DQ7, or DQ6 and DQ2 together, to determine if a sector is actively erasing or is erase-suspended. Refer to [Section 11. Write Operation Status on page 34](#) for information on these status bits.

After an erase-suspended program operation is complete, the bank returns to the erase-suspend-read mode. The system can determine the status of the program operation using the DQ7 or DQ6 status bits, just as in the standard Byte Program operation. Refer to [Section 11. Write Operation Status on page 34](#) for more information.

In the erase-suspend-read mode, the system can also issue the autoselect command sequence. The device allows reading autoselect codes even at addresses within erasing sectors, since the codes are not stored in the memory array. When the device exits the autoselect mode, the device reverts to the Erase Suspend mode, and is ready for another valid operation. Refer to [Section 8.9 Autoselect Mode on page 17](#) and [Section 10.3 Autoselect Command Sequence on page 28](#) for details.

To resume the sector erase operation, the system must write the Erase Resume command. The bank address of the erase-suspended bank is required when writing this command. Further writes of the Resume command are ignored. Another Erase Suspend command can be written after the chip has resumed erasing.

Notes

9. See [Table 12 on page 32](#) for erase command sequence.
10. See the section on DQ3 for information on the sector erase timer.

Table 12. S29JL064J Command Definitions

Command Sequence ^[11]		Cycles	Bus Cycles ^[Notes 12 through 15]												
			First		Second		Third		Fourth		Fifth		Sixth		
			Addr	Data	Addr	Data	Addr	Data	Addr	Data	Addr	Data	Addr	Data	
Read ^[16]		1	RA	RD											
Reset ^[17]		1	XXX	F0											
Autoselect ^[18]	Manufacturer ID	Word	4	555	AA	2AA	55	(BA)555	90	(BA)X00	01				
		Byte		AAA		555		(BA)AAA							
	Device ID ^[19]	Word	6	555	AA	2AA	55	(BA)555	90	(BA)X01	7E	(BA)X0E	02	(BA)X0F	01
		Byte		AAA		555		(BA)AAA		(BA)X02		(BA)X1C		(BA)X1E	
	Secured Silicon Region Factory Protect ^[10]	Word	4	555	AA	2AA	55	(BA)555	90	(BA)X03	81/41/01				
		Byte		AAA		555		(BA)AAA		(BA)X06					
	Boot Sector/Sector Block Protect Verify ^[11]	Word	4	555	AA	2AA	55	(BA)555	90	(SA)X02	00/01				
		Byte		AAA		555		(BA)AAA		(SA)X04					
Enter Secured Silicon Region		Word	3	555	AA	2AA	55	555	88						
		Byte		AAA		555		AAA							
Exit Secured Silicon Region		Word	4	555	AA	2AA	55	555	90	XXX	00				
		Byte		AAA		555		AAA							
Program		Word	4	555	AA	2AA	55	555	A0	PA	PD				
		Byte		AAA		555		AAA							
Unlock Bypass		Word	3	555	AA	2AA	55	555	20						
		Byte		AAA		555		AAA							
Unlock Bypass Program ^[12]		2	XXX	A0	PA	PD									
Unlock Bypass Reset ^[13]		2	XXX	90	XXX	00									
Chip Erase		Word	6	555	AA	2AA	55	555	80	555	AA	2AA	55	555	10
		Byte		AAA		555		AAA		AAA		555		AAA	
Sector Erase ^[17]		Word	6	555	AA	2AA	55	555	80	555	AA	2AA	55	SA	30
		Byte		AAA		555		AAA		AAA		555			
Erase Suspend ^[14]		1	BA	B0											
Erase Resume ^[15]		1	BA	30											
CFI Query ^[16]		Word	1	55	98										
		Byte		AA											

Legend

X = Don't care

RA = Address of the memory location to be read.

RD = Data read from location RA during read operation.

PA = Address of the memory location to be programmed. Addresses latch on the falling edge of the WE# or CE# pulse, whichever happens later.

PD = Data to be programmed at location PA. Data latches on the rising edge of WE# or CE# pulse, whichever happens first.

SA = Address of the sector to be verified (in autoselect mode) or erased. Address bits A21–A12 uniquely select any sector. Refer to Table 4 on page 16 for information on sector addresses.

BA = Address of the bank that is being switched to autoselect mode, is in bypass mode, or is being erased. A21–A19 uniquely select a bank.

Notes

11. See [Table 2 on page 10](#) for description of bus operations.
12. All values are in hexadecimal.
13. Except for the read cycle and the fourth, fifth, and sixth cycle of the autoselect command sequence, all bus cycles are write cycles.
14. Data bits DQ15–DQ8 are don't care in command sequences, except for RD and PD.
15. Unless otherwise noted, address bits A21–A11 are don't cares for unlock and command cycles, unless SA or PA is required.
16. No unlock or command cycles required when bank is reading array data.
17. The Reset command is required to return to the read mode (or to the erase-suspend-read mode if previously in Erase Suspend) when a bank is in the autoselect mode, or if DQ5 goes high (while the bank is providing status information).
18. The fourth cycle of the autoselect command sequence is a read cycle. The system must provide the bank address to obtain the manufacturer ID, device ID, or Secured Silicon Region factory protect information. Data bits DQ15–DQ8 are don't care. While reading the autoselect addresses, the bank address must be the same until a reset command is given. See [Section 10.3 Autoselect Command Sequence on page 28](#) for more information.
19. The device ID must be read across the fourth, fifth, and sixth cycles.
20. The data is 81h for factory locked, 41h for customer locked, and 01h for not factory/customer locked.
21. The data is 00h for an unprotected sector/sector block and 01h for a protected sector/sector block.
22. The Unlock Bypass command is required prior to the Unlock Bypass Program command.
23. The Unlock Bypass Reset command is required to return to the read mode when the bank is in the unlock bypass mode.
24. The system may read and program in non-erasing sectors, or enter the autoselect mode, when in the Erase Suspend mode. The Erase Suspend command is valid only during a sector erase operation, and requires the bank address.
25. The Erase Resume command is valid only during the Erase Suspend mode, and requires the bank address.
26. Command is valid when device is ready to read array data or when device is in autoselect mode.
27. Additional sector erase commands during the time-out period after an initial sector erase are one cycle long and identical to the sixth cycle of the sector erase command sequence (SA / 30).

11. Write Operation Status

The device provides several bits to determine the status of a program or erase operation: DQ2, DQ3, DQ5, DQ6, and DQ7. [Table 13 on page 38](#) and the following subsections describe the function of these bits. DQ7 and DQ6 each offer a method for determining whether a program or erase operation is complete or in progress. The device also provides a hardware-based output signal, RY/BY#, to determine whether an Embedded Program or Erase operation is in progress or has been completed.

11.1 DQ7: Data# Polling

The Data# Polling bit, DQ7, indicates to the host system whether an Embedded Program or Erase algorithm is in progress or completed, or whether a bank is in Erase Suspend. Data# Polling is valid after the rising edge of the final WE# pulse in the command sequence.

During the Embedded Program algorithm, the device outputs on DQ7 the complement of the datum programmed to DQ7. This DQ7 status also applies to programming during Erase Suspend. When the Embedded Program algorithm is complete, the device outputs the datum programmed to DQ7. The system must provide the program address to read valid status information on DQ7. If a program address falls within a protected sector, Data# Polling on DQ7 is active for approximately 1 μ s, then that bank returns to the read mode.

During the Embedded Erase algorithm, Data# Polling produces a 0 on DQ7. When the Embedded Erase algorithm is complete, or if the bank enters the Erase Suspend mode, Data# Polling produces a 1 on DQ7. The system must provide an address within any of the sectors selected for erasure to read valid status information on DQ7.

After an erase command sequence is written, if all sectors selected for erasing are protected, Data# Polling on DQ7 is active for approximately 3 ms, then the bank returns to the read mode. If not all selected sectors are protected, the Embedded Erase algorithm erases the unprotected sectors, and ignores the selected sectors that are protected. However, if the system reads DQ7 at an address within a protected sector, the status may not be valid.

When the system detects DQ7 has changed from the complement to true data, it can read valid data at DQ15–DQ0 (or DQ7–DQ0 for x8-only device) on the *following* read cycles. Just prior to the completion of an Embedded Program or Erase operation, DQ7 may change asynchronously with DQ15–DQ8 (DQ7–DQ0 for x8-only device) while Output Enable (OE#) is asserted low. That is, the device may change from providing status information to valid data on DQ7. Depending on when the system samples the DQ7 output, it may read the status or valid data. Even if the device has completed the program or erase operation and DQ7 has valid data, the data outputs on DQ15–DQ0 may be still invalid. Valid data on DQ15–DQ0 (or DQ7–DQ0 for x8-only device) will appear on successive read cycles.

[Table 13 on page 38](#) shows the outputs for Data# Polling on DQ7. [Figure 8 on page 35](#) shows the Data# Polling algorithm. [Figure 24 on page 51](#) shows the Data# Polling timing diagram.

Figure 8. Data# Polling Algorithm^[28, 29]

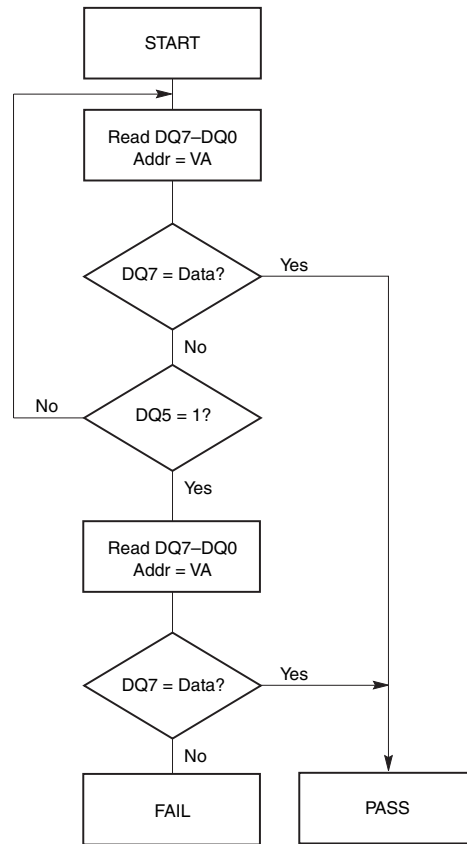

11.2 RY/BY#: Ready/Busy#

The RY/BY# is a dedicated, open-drain output pin which indicates whether an Embedded Algorithm is in progress or complete. The RY/BY# status is valid after the rising edge of the final WE# pulse in the command sequence. Since RY/BY# is an open-drain output, several RY/BY# pins can be tied together in parallel with a pull-up resistor to V_{CC} .

If the output is low (Busy), the device is actively erasing or programming. (This includes programming in the Erase Suspend mode.) If the output is high (Ready), the device is in the read mode, the standby mode, or one of the banks is in the erase-suspend-read mode.

Table 13 on page 38 shows the outputs for RY/BY#. When DQ5 is set to “1”, RY/BY# will be in the BUSY state, or “0”.

Notes

28. VA = Valid address for programming. During a sector erase operation, a valid address is any sector address within the sector being erased. During chip erase, a valid address is any non-protected sector address.

29. DQ7 should be rechecked even if DQ5 = 1 because DQ7 may change simultaneously with DQ5.

11.3 DQ6: Toggle Bit I

Toggle Bit I on DQ6 indicates whether an Embedded Program or Erase algorithm is in progress or complete, or whether the device has entered the Erase Suspend mode. Toggle Bit I may be read at any address, and is valid after the rising edge of the final WE# pulse in the command sequence (prior to the program or erase operation), and during the sector erase time-out.

During an Embedded Program or Erase algorithm operation, successive read cycles to any address cause DQ6 to toggle. The system may use either OE# or CE# to control the read cycles. When the operation is complete, DQ6 stops toggling.

After an erase command sequence is written, if all sectors selected for erasing are protected, DQ6 toggles for approximately 3 ms, then returns to reading array data. If not all selected sectors are protected, the Embedded Erase algorithm erases the unprotected sectors, and ignores the selected sectors that are protected.

The system can use DQ6 and DQ2 together to determine whether a sector is actively erasing or is erase-suspended. When the device is actively erasing (that is, the Embedded Erase algorithm is in progress), DQ6 toggles. When the device enters the Erase Suspend mode, DQ6 stops toggling. However, the system must also use DQ2 to determine which sectors are erasing or erase-suspended. Alternatively, the system can use DQ7 (see [Section 11.1 DQ7: Data# Polling on page 34](#)).

If a program address falls within a protected sector, DQ6 toggles for approximately 1 μs after the program command sequence is written, then returns to reading array data.

DQ6 also toggles during the erase-suspend-program mode, and stops toggling once the Embedded Program algorithm is complete.

Figure 9. Toggle Bit Algorithm^[30]

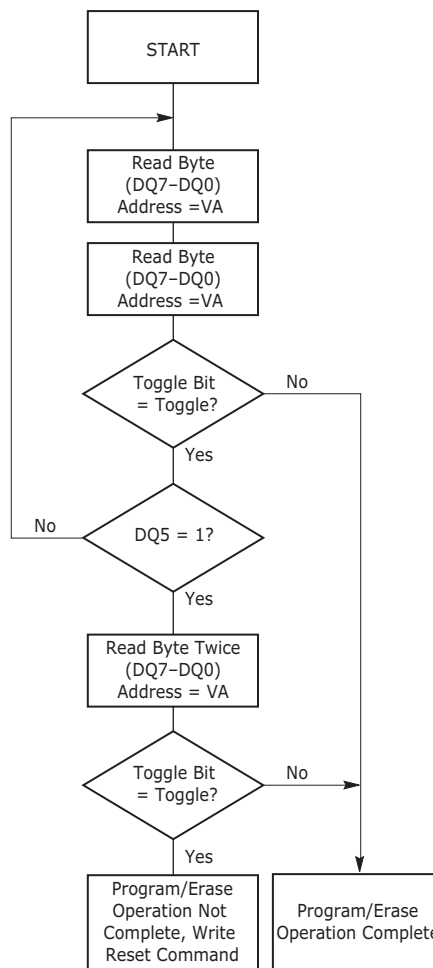

Note

30. The system should recheck the toggle bit even if DQ5 = 1 because the toggle bit may stop toggling as DQ5 changes to 1. See the subsections on DQ6 and DQ2 for more information.

11.4 DQ2: Toggle Bit II

The *Toggle Bit II* on DQ2, when used with DQ6, indicates whether a particular sector is actively erasing (that is, the Embedded Erase algorithm is in progress), or whether that sector is erase-suspended. Toggle Bit II is valid after the rising edge of the final WE# pulse in the command sequence.

DQ2 toggles when the system reads at addresses within those sectors that have been selected for erasure. (The system may use either OE# or CE# to control the read cycles.) But DQ2 cannot distinguish whether the sector is actively erasing or is erase-suspended. DQ6, by comparison, indicates whether the device is actively erasing, or is in Erase Suspend, but cannot distinguish which sectors are selected for erasure. Thus, both status bits are required for sector and mode information. Refer to [Table 13 on page 38](#) to compare outputs for DQ2 and DQ6.

[Figure 9 on page 36](#) shows the toggle bit algorithm in flowchart form, and [Section 11.4 DQ2: Toggle Bit II on page 37](#) explains the algorithm. See also [Section 11.3 DQ6: Toggle Bit I on page 36](#). [Figure 25 on page 51](#) shows the toggle bit timing diagram. [Figure 26 on page 52](#) shows the differences between DQ2 and DQ6 in graphical form.

11.5 Reading Toggle Bits DQ6/DQ2

Refer to [Figure 9 on page 36](#) for the following discussion. Whenever the system initially begins reading toggle bit status, it must read DQ15–DQ0 (or DQ7–DQ0 for x8-only device) at least twice in a row to determine whether a toggle bit is toggling. Typically, the system would note and store the value of the toggle bit after the first read. After the second read, the system would compare the new value of the toggle bit with the first. If the toggle bit is not toggling, the device has completed the program or erase operation. The system can read array data on DQ15–DQ0 (or DQ7–DQ0 for x8-only device) on the following read cycle.

However, if after the initial two read cycles, the system determines that the toggle bit is still toggling, the system also should note whether the value of DQ5 is high (see the section on DQ5). If it is, the system should then determine again whether the toggle bit is toggling, since the toggle bit may have stopped toggling just as DQ5 went high. If the toggle bit is no longer toggling, the device has successfully completed the program or erase operation. If it is still toggling, the device did not complete the operation successfully, and the system must write the reset command to return to reading array data.

The remaining scenario is that the system initially determines that the toggle bit is toggling and DQ5 has not gone high. The system may continue to monitor the toggle bit and DQ5 through successive read cycles, determining the status as described in the previous paragraph. Alternatively, it may choose to perform other system tasks. In this case, the system must start at the beginning of the algorithm when it returns to determine the status of the operation (top of [Figure 9 on page 36](#)).

11.6 DQ5: Exceeded Timing Limits

DQ5 indicates whether the program or erase time has exceeded a specified internal pulse count limit. Under these conditions DQ5 produces a *1*, indicating that the program or erase cycle was not successfully completed.

The device may output a *1* on DQ5 if the system tries to program a *1* to a location that was previously programmed to *0*. **Only an erase operation can change a *0* back to a *1*.** Under this condition, the device halts the operation, and when the timing limit has been exceeded, DQ5 produces a *1*.

Under both these conditions, the system must write the reset command to return to the read mode (or to the erase-suspend-read mode if a bank was previously in the erase-suspend-program mode).

11.7 DQ3: Sector Erase Timer

After writing a sector erase command sequence, the system may read DQ3 to determine whether or not erasure has begun. (The sector erase timer does not apply to the chip erase command.) If additional sectors are selected for erasure, the entire time-out also applies after each additional sector erase command. When the time-out period is complete, DQ3 switches from a 0 to a 1. If the time between additional sector erase commands from the system can be assumed to be less than 50 μ s, the system need not monitor DQ3. See also [Section 10.7 Sector Erase Command Sequence on page 30](#).

After the sector erase command is written, the system should read the status of DQ7 (Data# Polling) or DQ6 (Toggle Bit I) to ensure that the device has accepted the command sequence, and then read DQ3. If DQ3 is 1, the Embedded Erase algorithm has begun; all further commands (except Erase Suspend) are ignored until the erase operation is complete. If DQ3 is 0, the device will accept additional sector erase commands. To ensure the command has been accepted, the system software should check the status of DQ3 prior to and following each subsequent sector erase command. If DQ3 is high on the second status check, the last command might not have been accepted. The RDY/BSY# pin will be in the BUSY state under this condition.

[Table 13 on page 38](#) shows the status of DQ3 relative to the other status bits.

Table 13. Write Operation Status

Status		DQ7 ^[32]	DQ6	DQ5 ^[31]	DQ3	DQ2 ^[32]	RY/BY#	
Standard Mode	Embedded Program Algorithm	DQ7#	Toggle	0	N/A	No toggle	0	
	Embedded Erase Algorithm	in busy erasing sector	0	Toggle	0	1	Toggle	0
		in not busy erasing sector	0	Toggle	0	1	No toggle	0
Erase Suspend Mode	Erase-Suspend-Read	Erase Suspended Sector	1	No toggle	0	N/A	Toggle	1
		Non-Erase Suspended Sector	Data	Data	Data	Data	Data	1
	Erase-Suspend-Program	DQ7#	Toggle	0	N/A	N/A	0	

Notes

31. DQ5 switches to 1 when an Embedded Program or Embedded Erase operation has exceeded the maximum timing limits. Refer to the section on DQ5 for more information.
32. DQ7 and DQ2 require a valid address when reading status information. Refer to the appropriate subsection for further details.
33. When reading write operation status bits, the system must always provide the bank address where the Embedded Algorithm is in progress. The device outputs array data if the system addresses a non-busy bank.

12. Absolute Maximum Ratings

Storage Temperature, Plastic Packages	-65°C to +150°C
Ambient Temperature with Power Applied	-65°C to +125°C
Voltage with Respect to Ground	
V_{CC} ^[34]	-0.5V to +4.0V
A9 and RESET# ^[35]	-0.5V to +12.5V
WP#/ACC	-0.5V to +9.5V
All other pins ^[34]	-0.5V to V_{CC} +0.5V
Output Short Circuit Current ^[36]	200 mA

Notes

- 34. Minimum DC voltage on input or I/O pins is -0.5V. During voltage transitions, input or I/O pins may overshoot V_{SS} to -2.0V for periods of up to 20 ns. Maximum DC voltage on input or I/O pins is V_{CC} +0.5V. See Figure 10 on page 39. During voltage transitions, input or I/O pins may overshoot to V_{CC} +2.0V for periods up to 20 ns. See Figure 11 on page 39.
- 35. Minimum DC input voltage on pins A9, OE#, RESET#, and WP#/ACC is -0.5V. During voltage transitions, A9, OE#, WP#/ACC, and RESET# may overshoot V_{SS} to -2.0V for periods of up to 20 ns. See Figure 10 on page 39. Maximum DC input voltage on pin A9 is +12.5V which may overshoot to +14.0V for periods up to 20 ns. Maximum DC input voltage on WP#/ACC is +9.5V which may overshoot to +12.0V for periods up to 20 ns.
- 36. No more than one output may be shorted to ground at a time. Duration of the short circuit should not be greater than one second.
- 37. Stresses above those listed under "Absolute Maximum Ratings" may cause permanent damage to the device. This is a stress rating only; functional operation of the device at these or any other conditions above those indicated in the operational sections of this data sheet is not implied. Exposure of the device to absolute maximum rating conditions for extended periods may affect device reliability.

Figure 10. Maximum Negative Overshoot Waveform

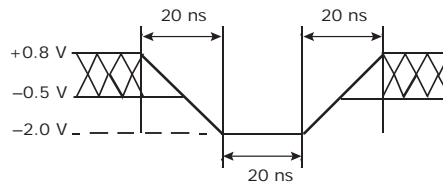
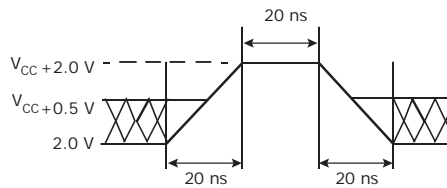

Figure 11. Maximum Positive Overshoot Waveform



13. Operating Ranges

Industrial (I) Devices

Ambient Temperature (T_A) -40°C to $+85^{\circ}\text{C}$

Automotive (A) Devices

Ambient Temperature (T_A) -40°C to $+85^{\circ}\text{C}$

V_{CC} Supply Voltages

V_{CC} for standard voltage range 2.7V to 3.6V

Operating ranges define those limits between which the functionality of the device is guaranteed.

14. DC Characteristics

14.1 CMOS Compatible

Parameter Symbol	Parameter Description	Test Conditions	Min	Typ	Max	Unit
I_{LI}	Input Load Current	$V_{IN} = V_{SS}$ to V_{CC} , $V_{CC} = V_{CC\ max}$			± 1.0	μA
I_{LIT}	A9 and RESET# Input Load Current	$V_{CC} = V_{CC\ max}$, OE# = V_{IH} ; A9 or RESET# = 12.5V			35	μA
I_{LO}	Output Leakage Current	$V_{OUT} = V_{SS}$ to V_{CC} , $V_{CC} = V_{CC\ max}$, OE# = V_{IH}			± 1.0	μA
I_{LR}	Reset Leakage Current	$V_{CC} = V_{CC\ max}$; RESET# = 12.5V			35	μA
I_{CC1}	V_{CC} Active Read Current ^[38, 39]	CE# = V_{IL} , OE# = V_{IH} , Byte Mode	5 MHz	10	16	mA
			1 MHz	2	4	
		CE# = V_{IL} , OE# = V_{IH} , Word Mode	5 MHz	10	16	
			1 MHz	2	4	
I_{CC2}	V_{CC} Active Write Current ^[38, 39]	CE# = V_{IL} , OE# = V_{IH} , WE# = V_{IL}		15	30	mA
I_{CC3}	V_{CC} Standby Current (Note 39)	CE#, RESET# = $V_{CC} \pm 0.3V$		0.2	5	μA
I_{CC4}	V_{CC} Reset Current (Note 39)	RESET# = $V_{SS} \pm 0.3V$		0.2	5	μA
I_{CC5}	Automatic Sleep Mode ^[39, 41]	$V_{IH} = V_{CC} \pm 0.3V$; $V_{IL} = V_{SS} \pm 0.3V$		0.2	5	μA
I_{CC6}	V_{CC} Active Read-While-Program Current ^[41]	CE# = V_{IL} , OE# = V_{IH} , 1 MHz	Byte	21	45	mA
			Word	21	45	
I_{CC7}	V_{CC} Active Read-While-Erase Current ^[41]	CE# = V_{IL} , OE# = V_{IH} , 1 MHz	Byte	21	45	mA
			Word	21	45	
I_{CC8}	V_{CC} Active Program-While-Erase-Suspended Current (Notes 39, 42)	CE# = V_{IL} , OE# = V_{IH}		17	35	mA
V_{IL}	Input Low Voltage		-0.5		0.8	V
V_{IH}	Input High Voltage		$0.7 \times V_{CC}$		$V_{CC} + 0.3$	V
V_{HH}	Voltage for WP#/ACC Sector Protect/Unprotect and Program Acceleration	$V_{CC} = 3.0V \pm 10\%$	8.5		9.5	V
V_{ID}	Voltage for Autoselect and Temporary Sector Unprotect	$V_{CC} = 3.0V \pm 10\%$	8.5		12.5	V
V_{OL}	Output Low Voltage	$I_{OL} = 2.0\ mA$, $V_{CC} = V_{CC\ min}$			0.45	V
V_{OH1}	Output High Voltage	$I_{OH} = -2.0\ mA$, $V_{CC} = V_{CC\ min}$	$0.85 V_{CC}$			V
V_{OH2}		$I_{OH} = -100\ \mu A$, $V_{CC} = V_{CC\ min}$	$V_{CC} - 0.4$			
V_{LKO}	Low V_{CC} Lock-Out Voltage ^[42]		1.8	2.0	2.5	V

Notes

38. The I_{CC} current listed is typically less than 2 mA/MHz, with OE# at V_{IH} .

39. Maximum I_{CC} specifications are tested with $V_{CC} = V_{CC\ max}$.

40. I_{CC} active while Embedded Erase or Embedded Program is in progress.

41. Automatic sleep mode enables the low power mode when addresses remain stable for $t_{ACC} + 30\ ns$. Typical sleep mode current is 200 nA.

42. Not 100% tested.

14.2 Zero-Power Flash

Figure 12. I_{CC1} Current vs. Time (Showing Active and Automatic Sleep Currents)^[43]

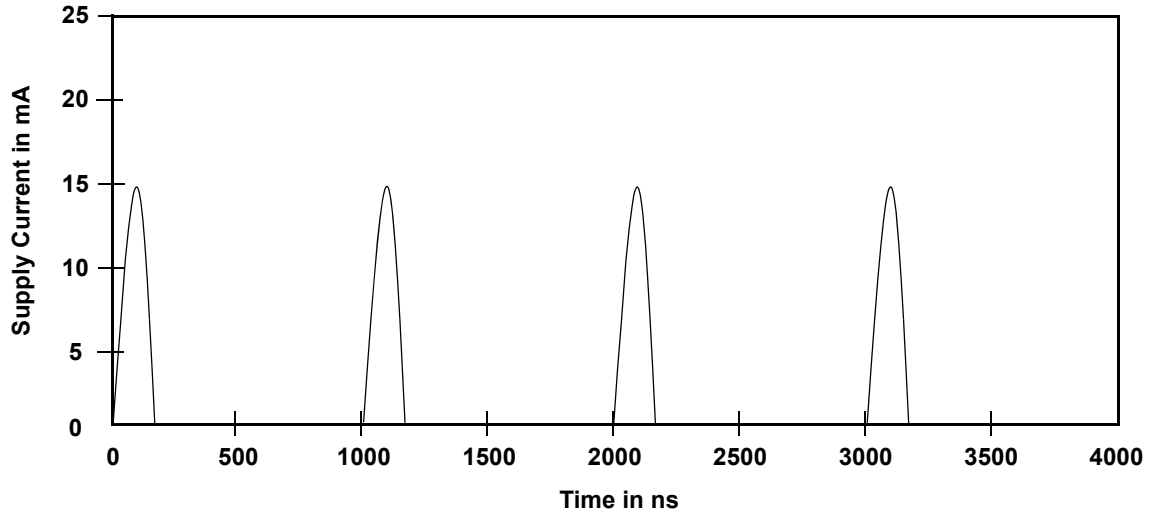
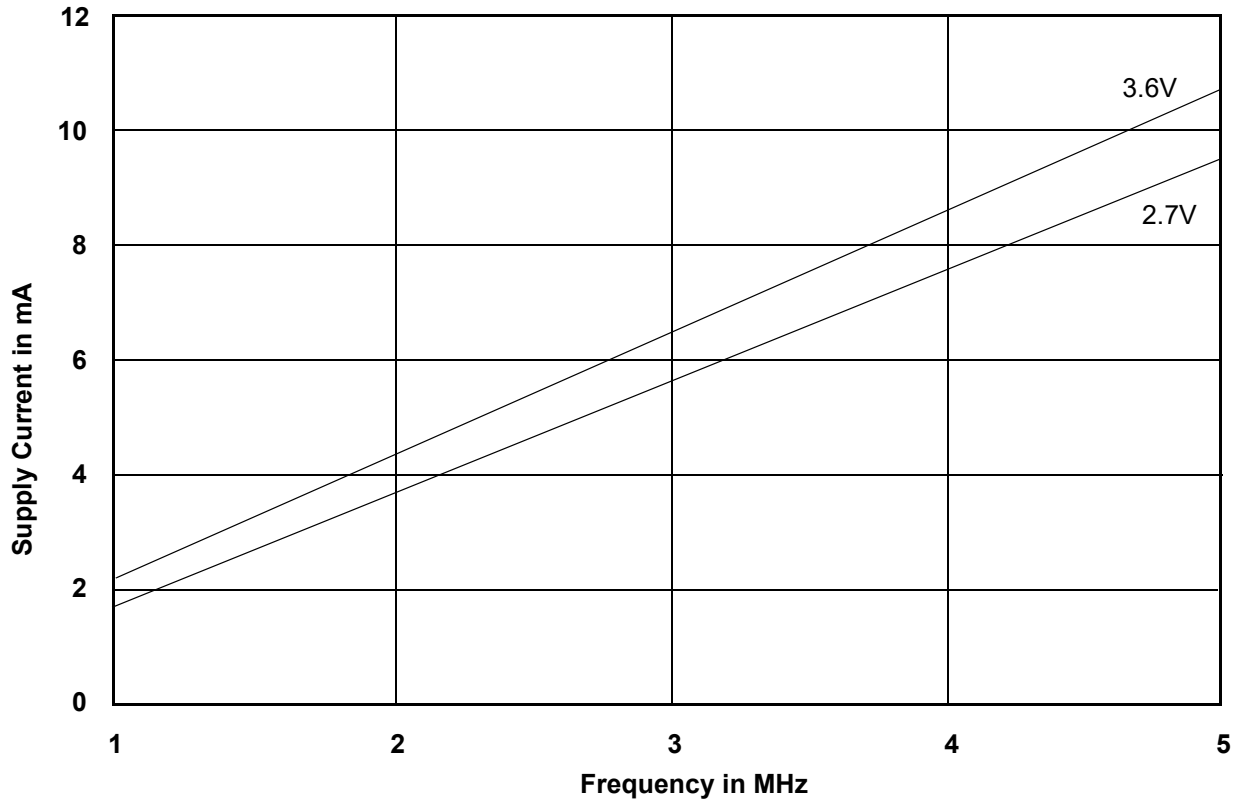

Figure 13. Typical I_{CC1} vs. Frequency^[44]



Notes

43. Addresses are switching at 1 MHz.

44. T = 25°C.

15. Test Conditions

Figure 14. Test Setup

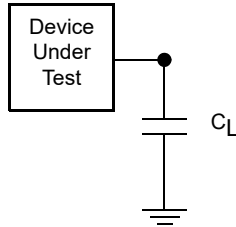

Table 14. Test Specifications

Test Condition	55, 60	70	Unit
Output Load Capacitance, C_L	30	100	pF
Input Rise and Fall Times ^[45]	5		ns
Input Pulse Levels	0.0 or V_{CC}		V
Input timing measurement reference levels	0.5 V_{CC}		V
Output timing measurement reference levels	0.5 V_{CC}		V

Note

45. Input rise and fall times are 0-100%.

16. Key To Switching Waveforms



Waveform	Inputs	Outputs
	Steady	
	Changing from H to L	
	Changing from L to H	
	Don't Care, Any Change Permitted	Changing, State Unknown
	Does Not Apply	Center Line is High Impedance State (High-Z)

Figure 15. Input Waveforms and Measurement Levels



17. AC Characteristics

17.1 Read-Only Operations

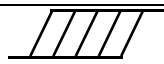
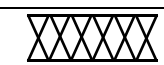
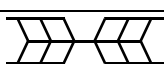
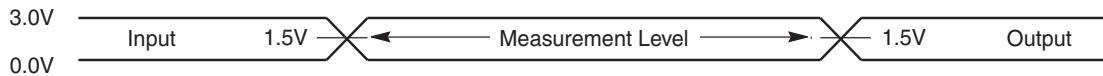
Parameter		Description	Test Setup	Speed Options				Unit
JEDEC	Std.			55	60	70		
t_{AVAV}	t_{RC}	Read Cycle Time ^[46]		Min	55	60	70	ns
t_{AVQV}	t_{ACC}	Address to Output Delay	CE#, OE# = V _{IL}	Max	55	60	70	ns
t_{ELQV}	t_{CE}	Chip Enable to Output Delay	OE# = V _{IL}	Max	55	60	70	ns
t_{GLQV}	t_{OE}	Output Enable to Output Delay		Max	25		30	ns
t_{EHQZ}	t_{DF}	Chip Enable to Output High-Z ^[46, 48]		Max	16			ns
t_{GHQZ}	t_{DF}	Output Enable to Output High-Z ^[46, 48]		Max	16			ns
t_{AXQX}	t_{OH}	Output Hold Time From Addresses, CE# or OE#, Whichever Occurs First		Min	0			ns
	t_{OEh}	Output Enable Hold Time ^[46]	Read	Min	0			ns
			Toggle and Data# Polling	Min	5	10		ns

Notes

46. Not 100% tested.

47. See Figure 14 on page 43 and Table 14 on page 43 for test specifications

48. Measurements performed by placing a 50 ohm termination on the data pin with a bias of V_{CC}/2. The time from OE# high to the data bus driven to V_{CC}/2 is taken as t_{DF}.

Figure 16. Read Operation Timings

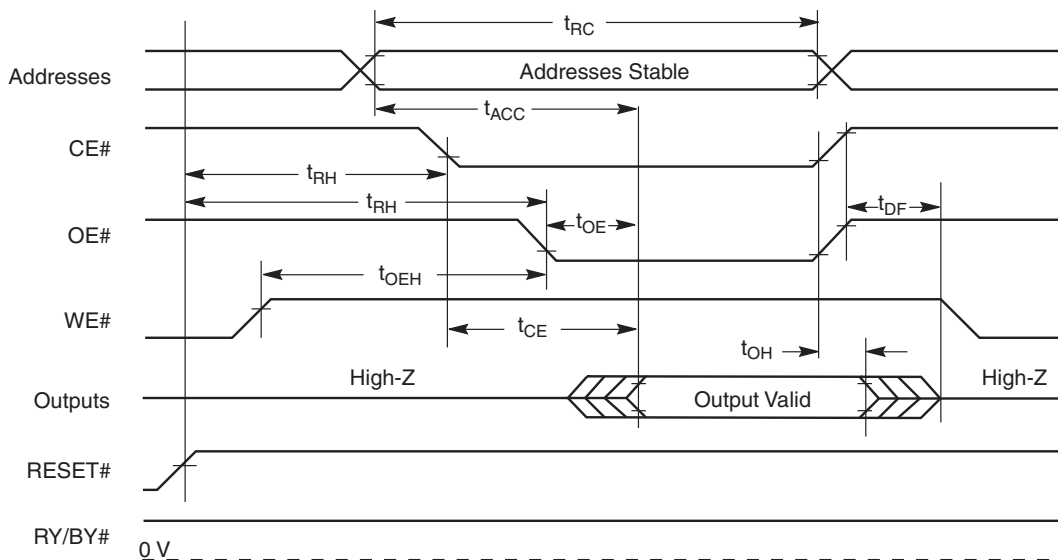

17.2 Hardware Reset (RESET#)

Parameter		Description		All Speed Options	Unit
JEDEC	Std				
	t_{Ready}	RESET# Pin Low (During Embedded Algorithms) to Read Mode (See Note)	Max	35	μs
	t_{Ready}	RESET# Pin Low (NOT During Embedded Algorithms) to Read Mode (See Note)	Max	500	ns
	t_{RP}	RESET# Pulse Width	Min	500	ns
	t_{RH}	Reset High Time Before Read (See Note)	Min	50	ns
	t_{RPD}	RESET# Low to Standby Mode	Min	35	μs
	t_{RB}	RY/BY# Recovery Time	Min	0	ns

Note
49. Not 100% tested.

Figure 17. Reset Timings

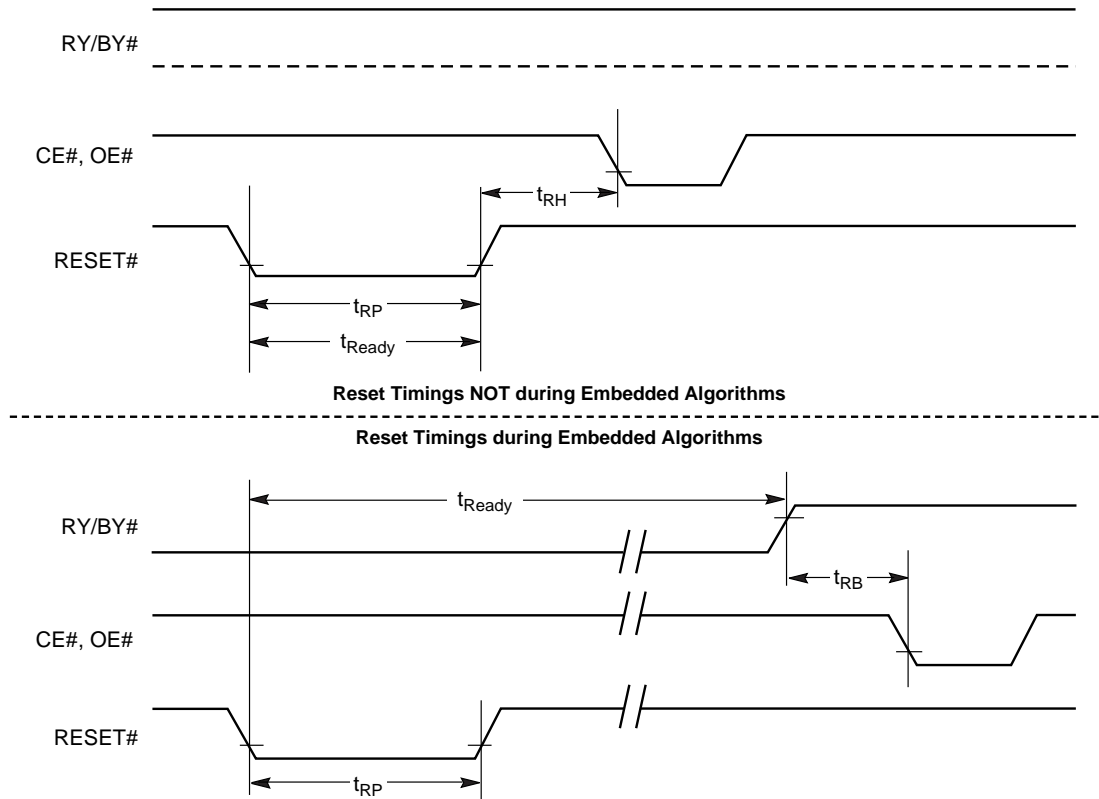

17.3 Word/Byte Configuration (BYTE#)

Parameter		Description		Speed Options			Unit
JEDEC	Std.			55	60	70	
	t_{ELFL}/t_{ELFH}	CE# to BYTE# Switching Low or High	Max	5			ns
	t_{FLQZ}	BYTE# Switching Low to Output High-Z	Max	16			ns
	t_{FHQV}	BYTE# Switching High to Output Active	Min	55	60	70	ns

Figure 18. BYTE# Timings for Read Operations

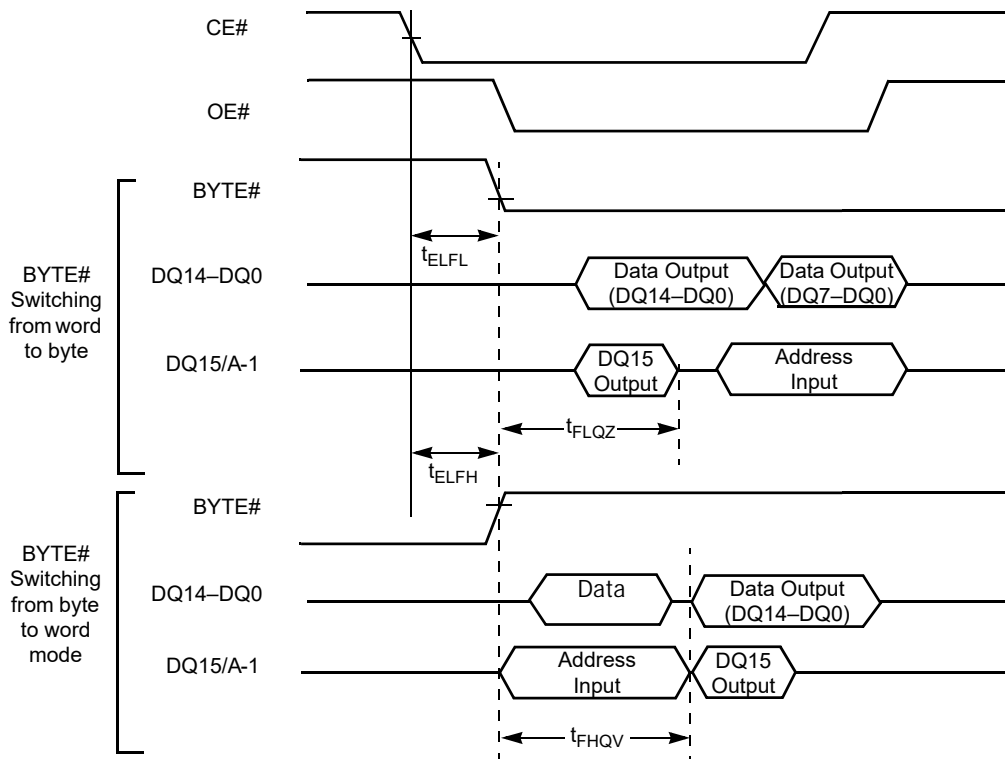
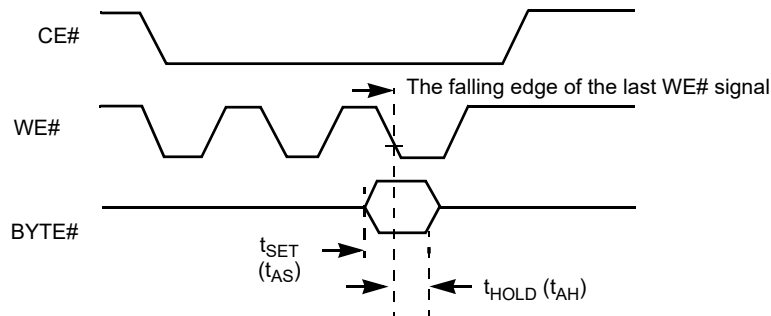

Figure 19. BYTE# Timings for Write Operations



Note
50. Refer to the Erase/Program Operations table for t_{AS} and t_{AH} specifications.

17.4 Erase and Program Operations

Parameter		Description		Speed Options			Unit
JEDEC	Std			55	60	70	
t_{AVAV}	t_{WC}	Write Cycle Time ^[51]	Min	55	60	70	ns
t_{AVWL}	t_{AS}	Address Setup Time	Min	0			ns
	t_{ASO}	Address Setup Time to OE# low during toggle bit polling	Min	15			ns
t_{WLAX}	t_{AH}	Address Hold Time	Min	30	35	40	ns
	t_{AHT}	Address Hold Time From CE# or OE# high during toggle bit polling	Min	0			ns
t_{DVWH}	t_{DS}	Data Setup Time	Min	30	35	40	ns
t_{WHDX}	t_{DH}	Data Hold Time	Min	0			ns
	t_{OEPH}	Output Enable High during toggle bit polling	Min	20			ns
t_{GHWL}	t_{GHWL}	Read Recovery Time Before Write (OE# High to WE# Low)	Min	0			ns
t_{ELWL}	t_{CS}	CE# Setup Time	Min	0			ns
t_{WHEH}	t_{CH}	CE# Hold Time	Min	0			ns
t_{WLWH}	t_{WP}	Write Pulse Width	Min	25	25	30	ns
t_{WHDL}	t_{WPH}	Write Pulse Width High	Min	25	25	30	ns
	$t_{SR/W}$	Latency Between Read and Write Operations	Min	0			ns
t_{WHWH1}	t_{WHWH1}	Programming Operation ^[52]	Byte	Typ	6		μ s
			Word	Typ	6		
t_{WHWH1}	t_{WHWH1}	Accelerated Programming Operation, Word or Byte ^[52]	Typ	4			μ s
t_{WHWH2}	t_{WHWH2}	Sector Erase Operation ^[52]	Typ	0.5			sec
	t_{VCS}	V _{CC} Setup Time ^[51]	Min	50			μ s
	t_{RB}	Write Recovery Time from RY/BY#	Min	0			ns
	t_{BUSY}	Program/Erase Valid to RY/BY# Delay	Max	90			ns
	t_{ESL}	Erase Suspend Latency	Max	35			μ s

Notes

51. Not 100% tested.

52. See [Section 18. Erase and Programming Performance on page 56](#) for more information.

Figure 20. Program Operation Timings^[53, 54]

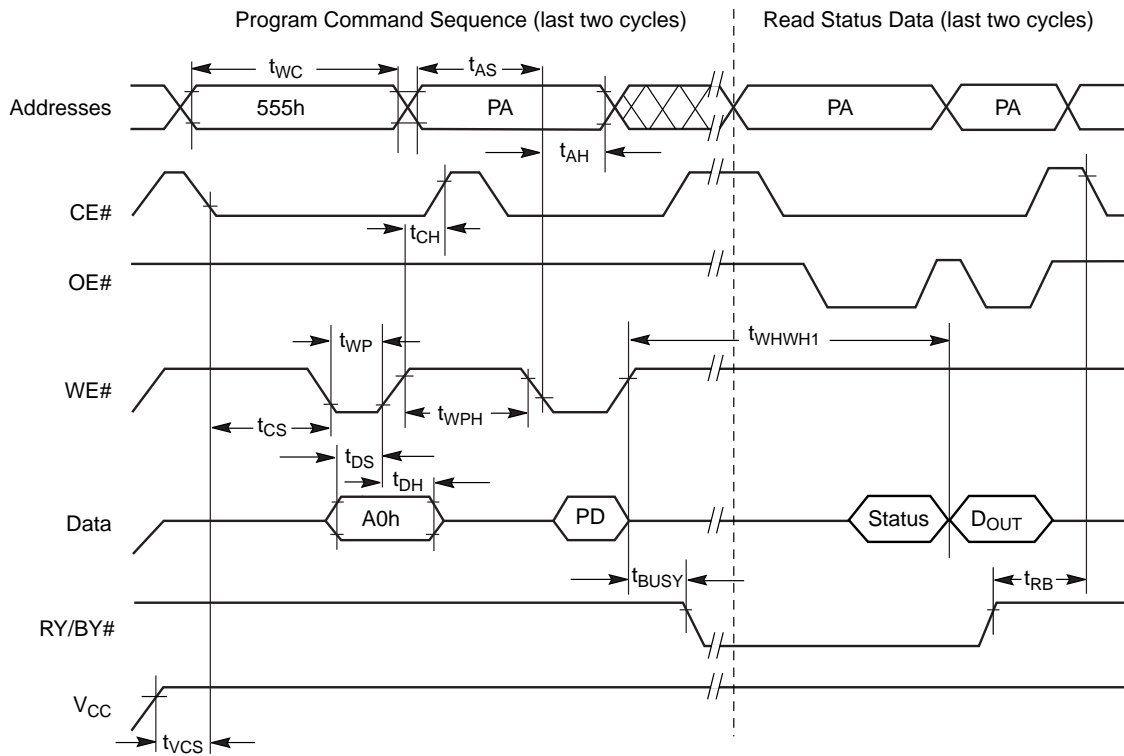
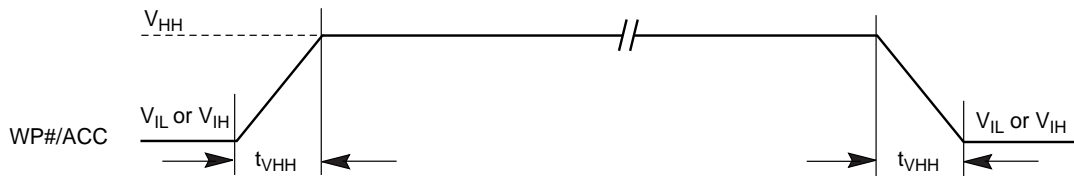

Figure 21. Accelerated Program Timing Diagram



Notes

53. PA = program address, PD = program data, D_{OUT} is the true data at the program address.
 54. Illustration shows device in word mode.

Figure 22. Chip/Sector Erase Operation Timings^[55, 56]

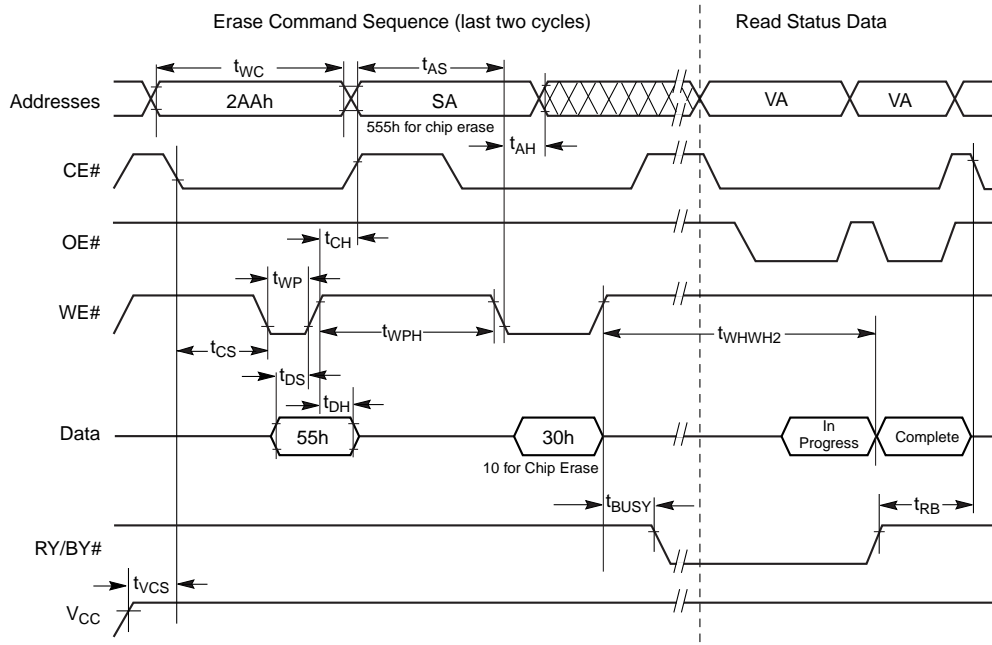
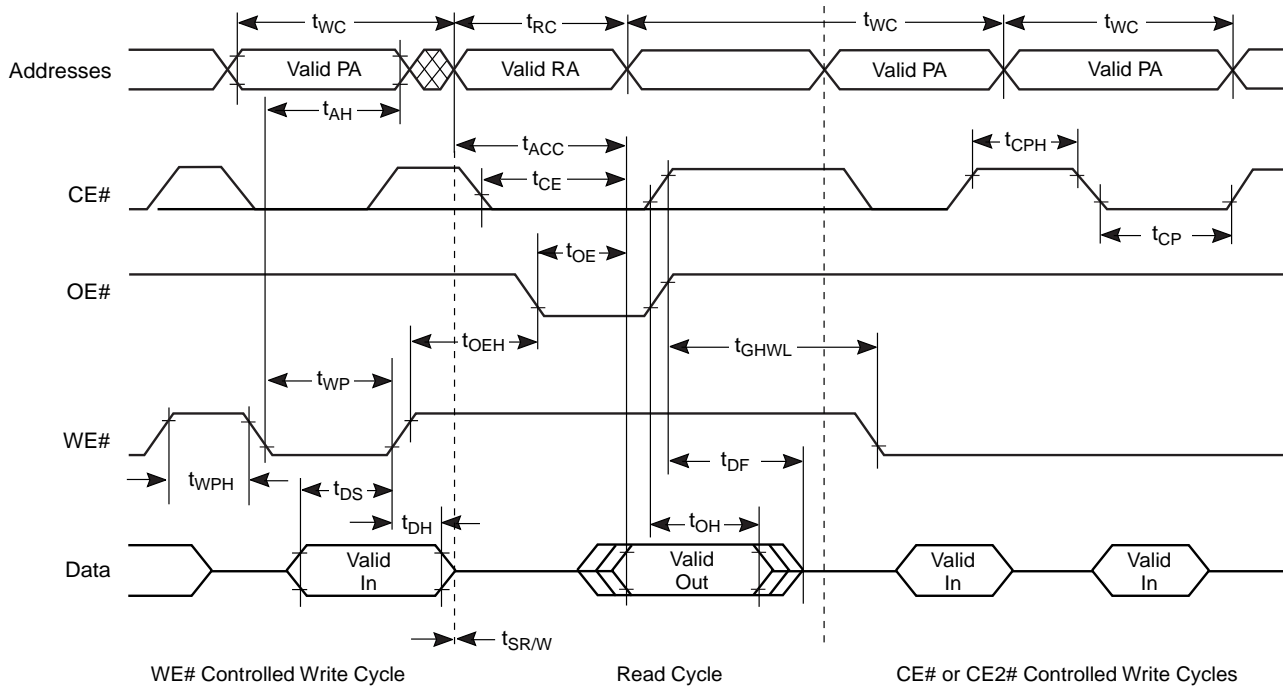

Figure 23. Back-to-back Read/Write Cycle Timings



Notes

55. SA = sector address (for Sector Erase), VA = Valid Address for reading status data (see Section 11. Write Operation Status on page 34).
 56. These waveforms are for the word mode.

Figure 24. Data# Polling Timings (During Embedded Algorithms)^[57]

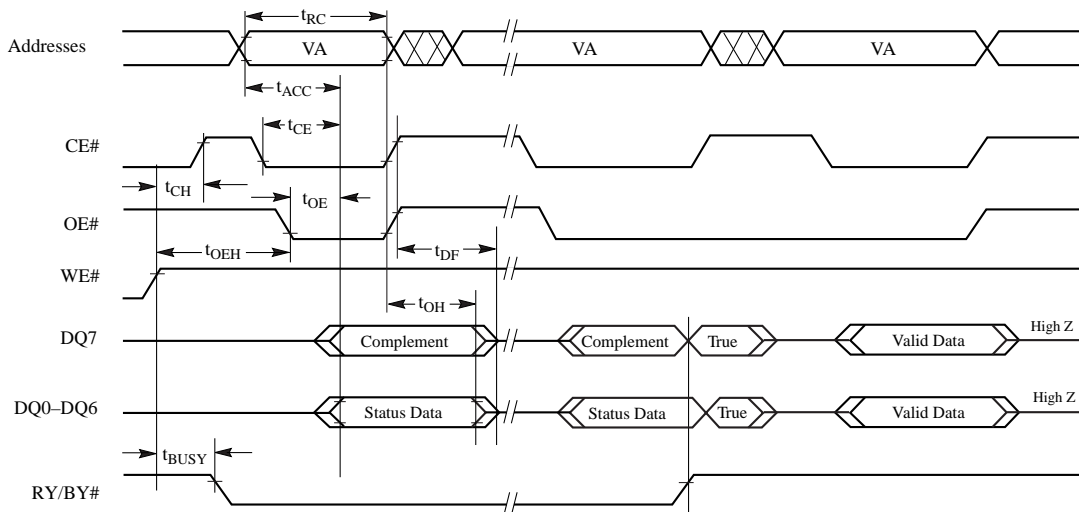
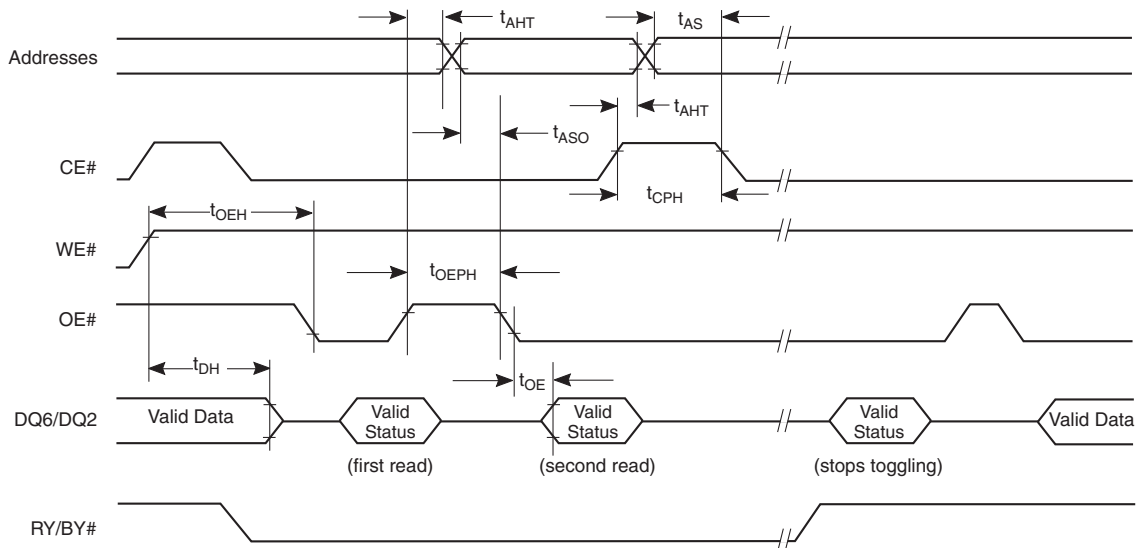

Figure 25. Toggle Bit Timings (During Embedded Algorithms)^[58]



Notes

- 57. VA = Valid address. Illustration shows first status cycle after command sequence, last status read cycle, and array data read cycle.
- 58. VA = Valid address; not required for DQ6. Illustration shows first two status cycle after command sequence, last status read cycle, and array data read cycle.

Figure 26. DQ2 vs. DQ6^[59]

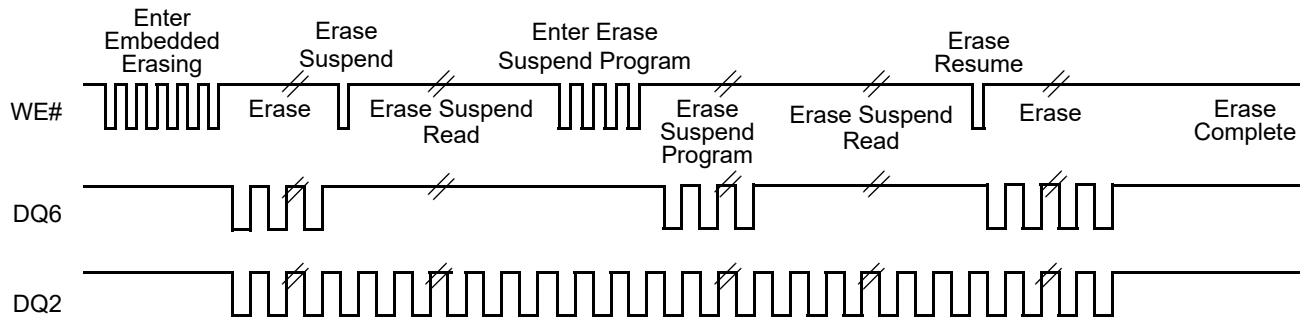

17.5 Temporary Sector Unprotect

Parameter		Description		All Speed Options	Unit
JEDEC	Std				
	t_{VIDR}	V_{ID} Rise and Fall Time ^[60]	Min	500	ns
	t_{VHH}	V_{HH} Rise and Fall Time ^[60]	Min	250	ns
	t_{RSP}	RESET# Setup Time for Temporary Sector Unprotect	Min	4	μ s
	t_{RRB}	RESET# Hold Time from RY/BY# High for Temporary Sector Unprotect	Min	4	μ s

Note
60. Not 100% tested.

Figure 27. Temporary Sector Unprotect Timing Diagram

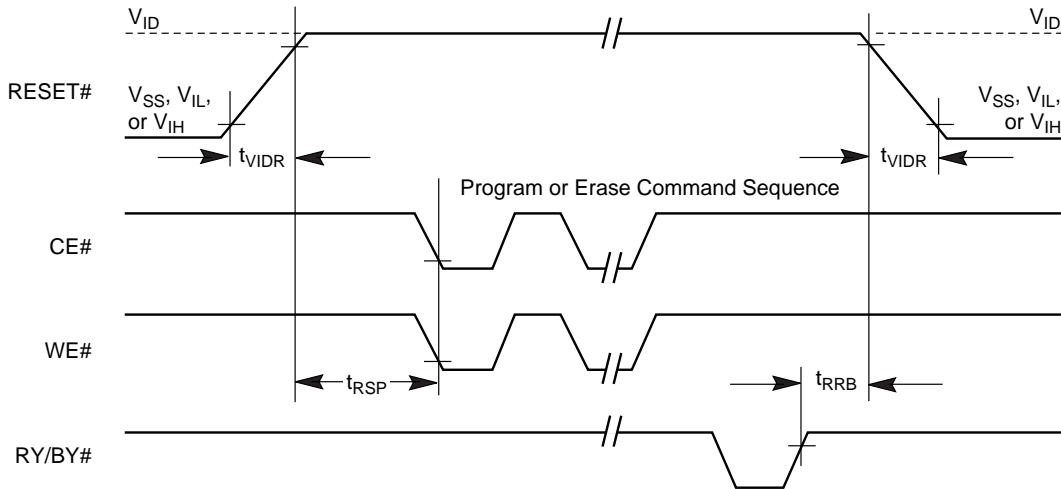

Note

59. DQ2 toggles only when read at an address within an erase-suspended sector. The system may use OE# or CE# to toggle DQ2 and DQ6.

Figure 28. Sector/Sector Block Protect and Unprotect Timing Diagram^[61]

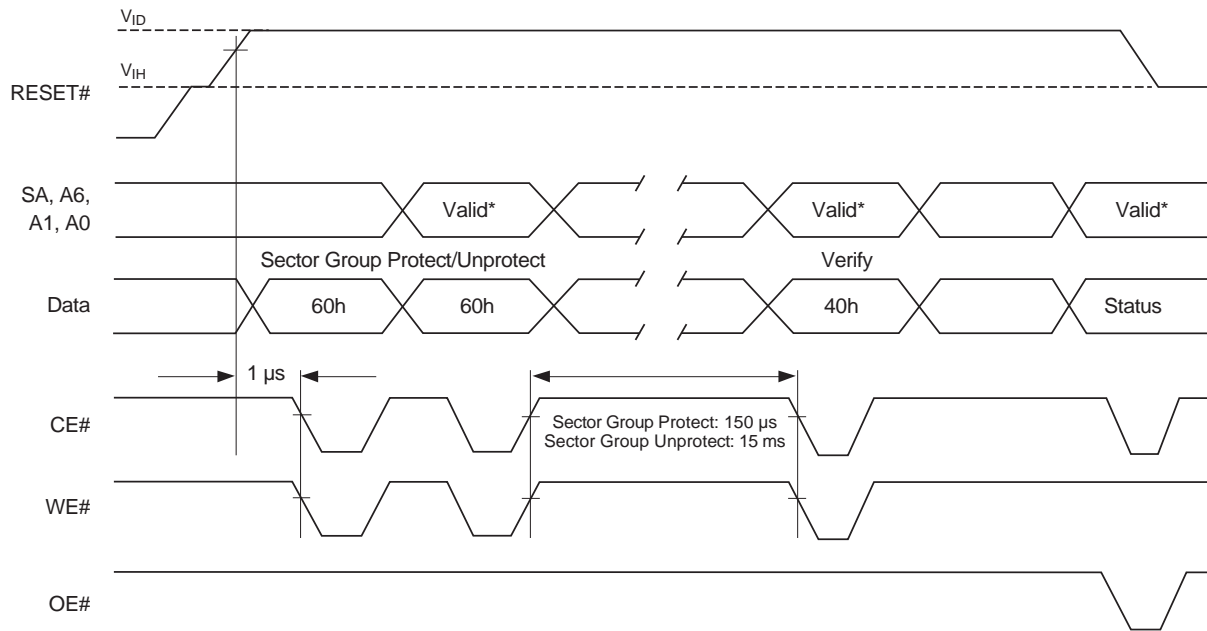

Note

61. For sector protect, A6 = 0, A1 = 1, A0 = 0. For sector unprotect, A6 = 1, A1 = 1, A0 = 0.

17.6 Alternate CE# Controlled Erase and Program Operations

Parameter		Description		Speed Options			Unit
JEDEC	Std.			55	60	70	
t_{AVAV}	t_{WC}	Write Cycle Time ^[62]	Min	55	60	70	ns
t_{AVWL}	t_{AS}	Address Setup Time	Min	0			ns
t_{ELAX}	t_{AH}	Address Hold Time	Min	30	35	40	ns
t_{DVEH}	t_{DS}	Data Setup Time	Min	30	35	40	ns
t_{EHDX}	t_{DH}	Data Hold Time	Min	0			ns
t_{GHLEL}	t_{GHLEL}	Read Recovery Time Before Write (OE# High to WE# Low)	Min	0			ns
t_{WLEL}	t_{WS}	WE# Setup Time	Min	0			ns
t_{EHWH}	t_{WH}	WE# Hold Time	Min	0			ns
t_{ELEH}	t_{CP}	CE# Pulse Width	Min	25	25	40	ns
t_{EHEL}	t_{CPH}	CE# Pulse Width High	Min	25	25	30	ns
t_{WHWH1}	t_{WHWH1}	Programming Operation ^[63]	Byte	Typ			μ s
			Word	Typ			
t_{WHWH1}	t_{WHWH1}	Accelerated Programming Operation, Word or Byte ^[63]	Typ	4			μ s
t_{WHWH2}	t_{WHWH2}	Sector Erase Operation ^[63]	Typ	0.5			sec

Notes

62. Not 100% tested.

63. See Section 18. Erase and Programming Performance on page 56 for more information.

Figure 29. Alternate CE# Controlled Write (Erase/Program) Operation Timings^[64, 65, 66, 67]

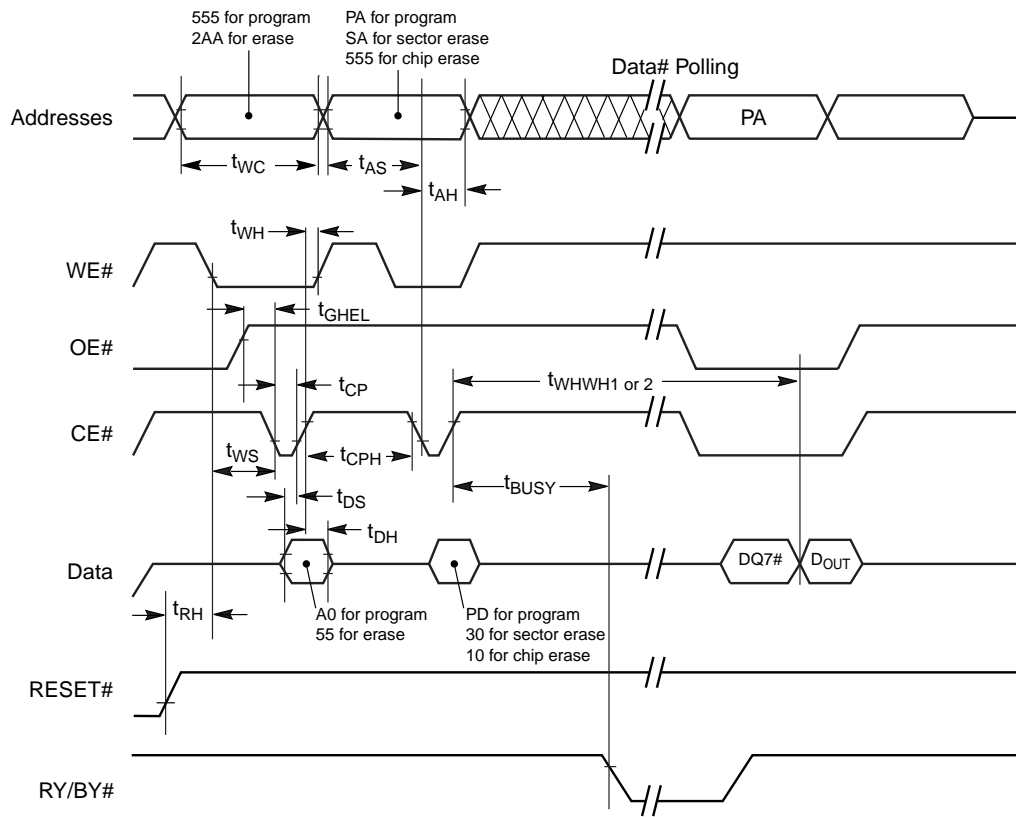

Notes

- 64. Figure indicates last two bus cycles of a program or erase operation.
- 65. PA = program address, SA = sector address, PD = program data.
- 66. DQ7# is the complement of the data written to the device. D_{OUT} is the data written to the device.
- 67. Waveforms are for the word mode.

18. Erase and Programming Performance

Parameter	Typ ^[68]	Max ^[69]	Unit	Comments
Sector Erase Time	0.5	5	sec	Excludes 00h programming prior to erasure ^[70]
Chip Erase Time	71		sec	
Byte Program Time	6	80	μs	Excludes system level overhead ^[71]
Word Program Time	6	80	μs	
Accelerated Byte/Word Program Time	4	70	μs	

Notes

68. Typical program and erase times assume the following conditions: 25°C, 3.0V V_{CC}, 100,000 cycles; checkerboard data pattern.

69. Under worst case conditions of 90°C, V_{CC} = 2.7V, 1,000,000 cycles.

70. In the pre-programming step of the Embedded Erase algorithm, all bytes are programmed to 00h before erasure.

71. System-level overhead is the time required to execute the two- or four-bus-cycle sequence for the program command. See [Table 12 on page 32](#) for further information on command definitions.

72. The device has a minimum program and erase cycle endurance of 100,000 cycles per sector.

19. Pin Capacitance

Parameter Symbol	Parameter Description	Test Setup	Max	Unit
C_{IN}	Input Capacitance (applies to A21-A0, DQ15-DQ0)	$V_{IN} = 0$	8.5	pF
C_{OUT}	Output Capacitance (applies to DQ15-DQ0, RY/BY#)	$V_{OUT} = 0$	5.5	pF
C_{IN2}	Control Pin Capacitance (applies to CE#, WE#, OE#, WP#/ACC, RESET#, BYTE#)	$V_{IN} = 0$	12	pF

Notes

73. Sampled, not 100% tested.

74. Test conditions $T_A = 25^{\circ}\text{C}$, $f = 1.0\text{ MHz}$.

20. Physical Dimensions

20.1 TS 048—48-Pin Standard TSOP

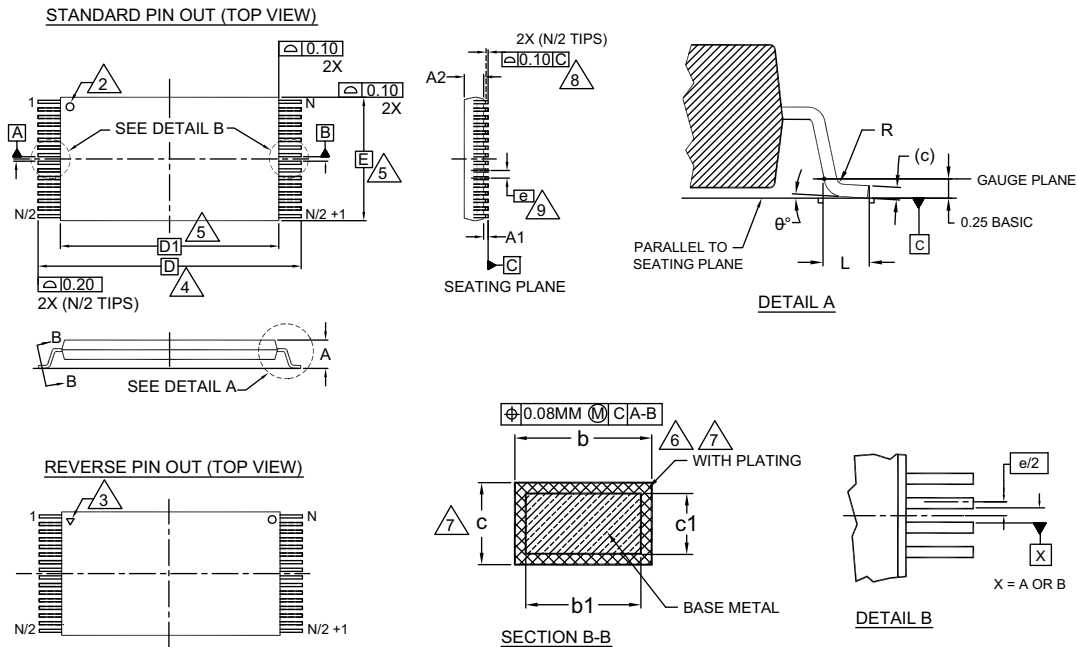

SYMBOL	DIMENSIONS		
	MIN.	NOM.	MAX.
A	—	—	1.20
A1	0.05	—	0.15
A2	0.95	1.00	1.05
b1	0.17	0.20	0.23
b	0.17	0.22	0.27
c1	0.10	—	0.16
c	0.10	—	0.21
D	20.00 BASIC		
D1	18.40 BASIC		
E	12.00 BASIC		
e	0.50 BASIC		
L	0.50	0.60	0.70
θ	0°	—	8
R	0.08	—	0.20
N	48		

NOTES:

- 1. DIMENSIONS ARE IN MILLIMETERS (mm).
- 2. PIN 1 IDENTIFIER FOR STANDARD PIN OUT (DIE UP).
- 3. PIN 1 IDENTIFIER FOR REVERSE PIN OUT (DIE DOWN): INK OR LASER MARK.
- 4. TO BE DETERMINED AT THE SEATING PLANE [C]. THE SEATING PLANE IS DEFINED AS THE PLANE OF CONTACT THAT IS MADE WHEN THE PACKAGE LEADS ARE ALLOWED TO REST FREELY ON A FLAT HORIZONTAL SURFACE.
- 5. DIMENSIONS D1 AND E DO NOT INCLUDE MOLD PROTRUSION. ALLOWABLE MOLD PROTRUSION ON E IS 0.15mm PER SIDE AND ON D1 IS 0.25mm PER SIDE.
- 6. DIMENSION b DOES NOT INCLUDE DAMBAR PROTRUSION. ALLOWABLE DAMBAR PROTRUSION SHALL BE 0.08mm TOTAL IN EXCESS OF b DIMENSION AT MAX. MATERIAL CONDITION. DAMBAR CANNOT BE LOCATED ON LOWER RADIUS OR THE FOOT. MINIMUM SPACE BETWEEN PROTRUSION AND AN ADJACENT LEAD TO BE 0.07mm.
- 7. THESE DIMENSIONS APPLY TO THE FLAT SECTION OF THE LEAD BETWEEN 0.10mm AND 0.25mm FROM THE LEAD TIP.
- 8. LEAD COPLANARITY SHALL BE WITHIN 0.10mm AS MEASURED FROM THE SEATING PLANE.
- 9. DIMENSION "e" IS MEASURED AT THE CENTERLINE OF THE LEADS.
- 10. JEDEC SPECIFICATION NO. REF: MO-142(D)DD.

51-85183 *F

20.2 VBK048—48-Pin FBGA

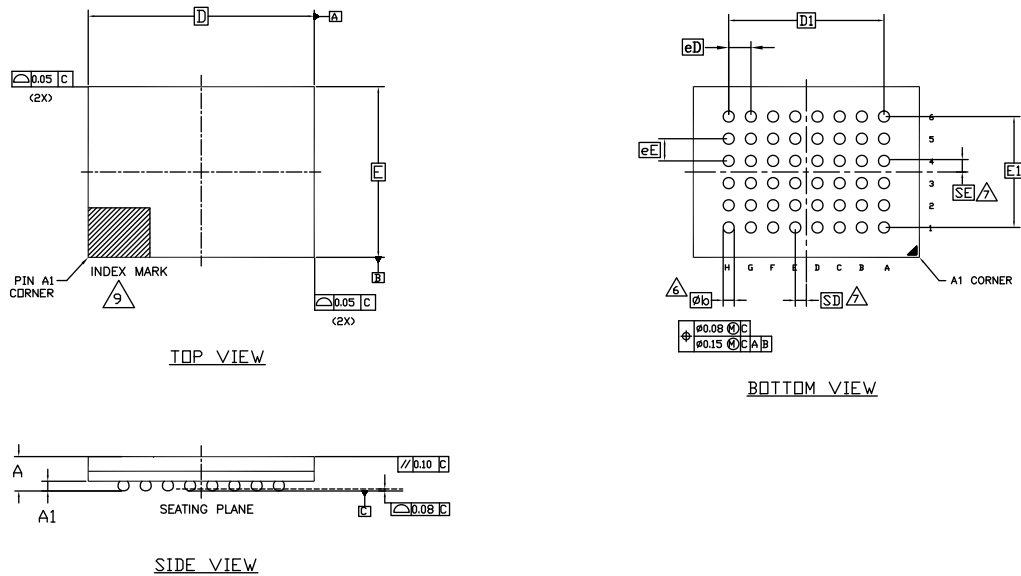

SYMBOL	DIMENSIONS		
	MIN.	NOM.	MAX.
A	—	—	1.00
A1	0.18	—	—
D	8.15 BSC.		
E	6.15 BSC.		
D1	5.60 BSC.		
E1	4.00 BSC.		
MD	8		
ME	6		
n	48		
φb	0.33	—	0.43
eD/eE	0.80 BSC.		
SD/SE	0.40 BSC.		

NOTES:

- DIMENSIONING AND TOLERANCING PER ASME Y14.5M-1994 .
- ALL DIMENSIONS ARE IN MILLIMETERS .
- BALL POSITION DESIGNATION PER JEP95, SECTION 3, SPP-010/020.
- REPRESENTS THE SOLDER BALL GRID PITCH .
- SYMBOL "MD" IS THE BALL ROW MATRIX SIZE IN THE "D" DIRECTION.
SYMBOL "ME" IS THE BALL COLUMN MATRIX SIZE IN THE "E" DIRECTION.
n IS THE TOTAL NUMBER OF POPULATED SOLDER BALLS FOR MATRIX SIZE MD AND ME.
- △ "b" DIMENSION "b" IS MEASURED AT THE MAXIMUM BALL DIAMETER IN A PLANE PARALLEL TO DATUM C.
- △ "SD" AND "SE" ARE MEASURED WITH RESPECT TO DATUMS A AND B AND DEFINE THE POSITION OF THE CENTER SOLDER BALL IN THE OUTER ROW.
WHEN THERE IS AN ODD NUMBER OF SOLDER BALLS IN THE OUTER ROW, "SD" OR "SE" = 0.
WHEN THERE IS AN EVEN NUMBER OF SOLDER BALLS IN THE OUTER ROW, "SD" = eD/2 and "SE" = eE/2.
- "+" INDICATES THE THEORETICAL CENTER OF DEPOPULATED BALLS.
- △ A1 CORNER TO BE IDENTIFIED BY CHAMFER, LASER OR INK MARK, METALLIZED MARK INDENTATION OR OTHER MEANS.

002-19063 **

21. Revision History

Document History Page

Document Title: S29JL064J, 64-Mb (8M × 8-Bit/4M × 16-Bit), 3 V, Simultaneous Read/Write Flash Document Number: 002-00856			
Rev.	ECN No.	Submission Date	Description of Change
**	–	06/21/2010	Initial release
*A	–	09/01/2010	<p>Global Updated the data sheet designation from <i>Advanced Information</i> to <i>Preliminary</i>. Corrected spelling, capitalization, and grammatical errors.</p> <p>Simultaneous Read/Write Operations with Zero Latency Added clarification that JL064J is only offered as a dual boot device with both top and bottom boot sectors.</p> <p>Ordering Information Clarified that Note 1 applies to the Packing Type column.</p> <p>Device Bus Operations The note for the Addresses column should be Note 1, not Note 2.</p> <p>RESET#: Hardware Reset Pin Changed “Refer to AC Characteristics on page 46” to “Refer to Hardware Reset (RESET#) on page 47”.</p> <p>Secured Silicon Region Clarified the Secured Silicon Indicator Bit data based on factory and customer lock status. Removed forward looking statements regarding factory locking features as they are supported in this device.</p> <p>Common Flash Memory Interface (CFI) Clarified that once in the CFI query mode, the system must write the reset command to return to reading array data.</p> <p>Enter Secured Silicon Region/Exit Secured Silicon Region Command Sequence Removed the incorrect generalizing statement that the Secured Silicon Region always contains an ESN.</p> <p>Erase Suspend/Erase Resume Commands Added clarification that “It is not recommended to program the Secured Silicon Region after an erase suspend, as proper device functionality cannot be guaranteed.” In Table 10.1, corrected the Secured Silicon Region Factory Protect fourth cycle data from 81/01 to 81/41/01.</p> <p>Erase and Programming Performance Added Note 5 regarding minimum program and erase cycle endurance.</p> <p>Pin Capacitance Changed section title from “TSOP Pin Capacitance” to “Pin Capacitance”. Updated values to reflect maximum capacitances for both TSOP and BGA. Removed typical capacitance values. Added specific pin clarifications to parameter descriptions.</p> <p>Physical Dimensions Updated the VBK048 package outline drawing.</p>

Document History Page (Continued)

Document Title: S29JL064J, 64-Mb (8M × 8-Bit/4M × 16-Bit), 3 V, Simultaneous Read/Write Flash Document Number: 002-00856			
Rev.	ECN No.	Submission Date	Description of Change
*B	–	04/07/2011	<p>Global Updated the data sheet designation from Preliminary to Full Production (no designation on document).</p> <p>RESET#: Hardware Reset Pin Added warning that keeping CE# at VIL from power up through the first reset could cause erroneous data on the first read.</p> <p>Reset Command Clarified that during an embedded program or erase, if DQ5 goes high then RY/BY# will remain low until a reset is issued</p> <p>Absolute Maximum Ratings Corrected the maximum value of WP#/ACC voltage with respect to ground from +10.5V to +9.5V</p> <p>DC Characteristics Corrected voltage for autoselect and temporary sector unprotect (VID) minimum value from 11.5V to 8.5V</p> <p>Test Conditions Changed the format of the input pulse levels and input and output timing measurement reference levels to match the JL032J data sheet format</p> <p>Hardware Reset (RESET#) Added note to “Reset Timings” figure clarifying that CE# should only go low after RESET# has gone high.</p>
*C	–	08/24/2011	<p>RESET#: Hardware Reset Pin Removed warning that keeping CE# at VIL from power up through the first reset could cause erroneous data on the first read.</p> <p>Sector Erase Command Sequence Added clarification regarding additional sector erase commands during time-out period.</p> <p>Command Definitions Table Added Note 17 to clarify additional sector erase commands during time-out period.</p> <p>Hardware Reset (RESET#) Removed note to the “Reset Timings” figure clarifying that CE# should only go low after RESET# has gone high.</p> <p>Erase and Programming Performance Updated Byte Program Time and Word Program Time to 80 μs.</p> <p>Physical Dimensions Package drawings updated to latest version</p>
*D	–	12/16/2011	<p>Global Corrected all references in the text to the sector erase time-out period from 80 μs to 50 μs.</p>
*E	5038713	12/08/2015	Updated to Cypress template.
*F	5705425	04/21/2017	Updated Cypress Logo and Copyright.
*G	5766160	06/07/2017	<p>Updated Ordering Information on page 8: Added “Valid Combinations — Automotive Grade / AEC-Q100”.</p> <p>Updated Operating Ranges on page 40: Added Automotive Temperature Range related information.</p>
*H	6213951	08/23/2018	<p>Updated Ordering Information on page 8: Updated Valid Combinations — Automotive Grade / AEC-Q100: Added “70 ns” speed bin related information.</p> <p>Updated Physical Dimensions on page 58: Updated TS 048—48-Pin Standard TSOP on page 58: Removed spec “3664 \ f16-038.10 \ 11.6.7”. Added spec 51-85183 *F.</p> <p>Updated VBK048—48-Pin FBGA on page 59: Removed spec “g1001.2 \ f16-038.25 \ 07.13.10”. Added spec 002-19063 **.</p> <p>Updated to new template.</p>

Document History Page (Continued)

Document Title: S29JL064J, 64-Mb (8M × 8-Bit/4M × 16-Bit), 3 V, Simultaneous Read/Write Flash Document Number: 002-00856			
Rev.	ECN No.	Submission Date	Description of Change
*I	6349975	10/15/2018	Updated Ordering Information on page 8 : Updated Valid Combinations — Automotive Grade / AEC-Q100: Added “55 ns” speed bin related information. Updated to new template. Completing Sunset Review.
*J	6661743	10/17/2019	Updated Ordering Information on page 8 : Updated Valid Combinations — Standard: Removed “60 ns” speed bin related information. Updated to new template. Completing Sunset Review.

Sales, Solutions, and Legal Information

Worldwide Sales and Design Support

Cypress maintains a worldwide network of offices, solution centers, manufacturer's representatives, and distributors. To find the office closest to you, visit us at [Cypress Locations](#).

Products

Arm® Cortex® Microcontrollers	cypress.com/arm
Automotive	cypress.com/automotive
Clocks & Buffers	cypress.com/clocks
Interface	cypress.com/interface
Internet of Things	cypress.com/iot
Memory	cypress.com/memory
Microcontrollers	cypress.com/mcu
PSoC	cypress.com/psoc
Power Management ICs	cypress.com/pmic
Touch Sensing	cypress.com/touch
USB Controllers	cypress.com/usb
Wireless Connectivity	cypress.com/wireless

PSoC® Solutions

[PSoC 1](#) | [PSoC 3](#) | [PSoC 4](#) | [PSoC 5LP](#) | [PSoC 6 MCU](#)

Cypress Developer Community

[Community](#) | [Projects](#) | [Video](#) | [Blogs](#) | [Training](#) | [Components](#)

Technical Support

cypress.com/support

© Cypress Semiconductor Corporation, 2010–2019. This document is the property of Cypress Semiconductor Corporation and its subsidiaries ("Cypress"). This document, including any software or firmware included or referenced in this document ("Software"), is owned by Cypress under the intellectual property laws and treaties of the United States and other countries worldwide. Cypress reserves all rights under such laws and treaties and does not, except as specifically stated in this paragraph, grant any license under its patents, copyrights, trademarks, or other intellectual property rights. If the Software is not accompanied by a license agreement and you do not otherwise have a written agreement with Cypress governing the use of the Software, then Cypress hereby grants you a personal, non-exclusive, nontransferable license (without the right to sublicense) (1) under its copyright rights in the Software (a) for Software provided in source code form, to modify and reproduce the Software solely for use with Cypress hardware products, only internally within your organization, and (b) to distribute the Software in binary code form externally to end users (either directly or indirectly through resellers and distributors), solely for use on Cypress hardware product units, and (2) under those claims of Cypress's patents that are infringed by the Software (as provided by Cypress, unmodified) to make, use, distribute, and import the Software solely for use with Cypress hardware products. Any other use, reproduction, modification, translation, or compilation of the Software is prohibited.

TO THE EXTENT PERMITTED BY APPLICABLE LAW, CYPRESS MAKES NO WARRANTY OF ANY KIND, EXPRESS OR IMPLIED, WITH REGARD TO THIS DOCUMENT OR ANY SOFTWARE OR ACCOMPANYING HARDWARE, INCLUDING, BUT NOT LIMITED TO, THE IMPLIED WARRANTIES OF MERCHANTABILITY AND FITNESS FOR A PARTICULAR PURPOSE. No computing device can be absolutely secure. Therefore, despite security measures implemented in Cypress hardware or software products, Cypress shall have no liability arising out of any security breach, such as unauthorized access to or use of a Cypress product. CYPRESS DOES NOT REPRESENT, WARRANT, OR GUARANTEE THAT CYPRESS PRODUCTS, OR SYSTEMS CREATED USING CYPRESS PRODUCTS, WILL BE FREE FROM CORRUPTION, ATTACK, VIRUSES, INTERFERENCE, HACKING, DATA LOSS OR THEFT, OR OTHER SECURITY INTRUSION (collectively, "Security Breach"). Cypress disclaims any liability relating to any Security Breach, and you shall and hereby do release Cypress from any claim, damage, or other liability arising from any Security Breach. In addition, the products described in these materials may contain design defects or errors known as errata which may cause the product to deviate from published specifications. To the extent permitted by applicable law, Cypress reserves the right to make changes to this document without further notice. Cypress does not assume any liability arising out of the application or use of any product or circuit described in this document. Any information provided in this document, including any sample design information or programming code, is provided only for reference purposes. It is the responsibility of the user of this document to properly design, program, and test the functionality and safety of any application made of this information and any resulting product. "High-Risk Device" means any device or system whose failure could cause personal injury, death, or property damage. Examples of High-Risk Devices are weapons, nuclear installations, surgical implants, and other medical devices. "Critical Component" means any component of a High-Risk Device whose failure to perform can be reasonably expected to cause, directly or indirectly, the failure of the High-Risk Device, or to affect its safety or effectiveness. Cypress is not liable, in whole or in part, and you shall and hereby do release Cypress from any claim, damage, or other liability arising from any use of a Cypress product as a Critical Component in a High-Risk Device. You shall indemnify and hold Cypress, its directors, officers, employees, agents, affiliates, distributors, and assigns harmless from and against all claims, costs, damages, and expenses, arising out of any claim, including claims for product liability, personal injury or death, or property damage arising from any use of a Cypress product as a Critical Component in a High-Risk Device. Cypress products are not intended or authorized for use as a Critical Component in any High-Risk Device except to the limited extent that (i) Cypress's published data sheet for the product explicitly states Cypress has qualified the product for use in a specific High-Risk Device, or (ii) Cypress has given you advance written authorization to use the product as a Critical Component in the specific High-Risk Device and you have signed a separate indemnification agreement.

Cypress, the Cypress logo, Spansion, the Spansion logo, and combinations thereof, WICED, PSoC, CapSense, EZ-USB, F-RAM, and Traveo are trademarks or registered trademarks of Cypress in the United States and other countries. For a more complete list of Cypress trademarks, visit cypress.com. Other names and brands may be claimed as property of their respective owners.

Looking for pricing, stock, or lifecycle information?

Click below to explore more details on WIN SOURCE:

 [View S29JL064J60TFI003 on WIN SOURCE](#)

 [Infineon Technologies](#) Information

Optimize Your Supply Chain with WIN SOURCE Solutions

-  Global Sourcing Solution
-  Obsolete Management
-  Cost Control Management
-  Shortage Management
-  Alternative Solution
-  Excess Inventory Management