



**THE DATASHEET OF
IS62WV12816DBLL-45BLI**



128K x 16 LOW VOLTAGE, ULTRA LOW POWER CMOS STATIC RAM

JUNE 2013

FEATURES

- High-speed access time: 35ns, 45ns, 55ns
- CMOS low power operation
 - 36 mW (typical) operating
 - 9 μ W (typical) CMOS standby
- TTL compatible interface levels
- Single power supply
 - 1.8V \pm 10% V_{DD} (IS62/65WV12816DALL)
 - 2.5V--3.6V V_{DD} (IS62/65WV12816DBLL)
- Fully static operation: no clock or refresh required
- Three state outputs
- Data control for upper and lower bytes
- Industrial and Autotmovie temperature support
- 2CS Option Available
- Lead-free available

DESCRIPTION

The *ISSI* IS62/65WV12816DALL/DBLL are high-speed, 2M bit static RAMs organized as 128K words by 16 bits. It is fabricated using *ISSI*'s high-performance CMOS technology. This highly reliable process coupled with innovative circuit design techniques, yields high-performance and low power consumption devices.

When $\overline{CS1}$ is HIGH (deselected) or when $\overline{CS2}$ is LOW (deselected) or when $\overline{CS1}$ is LOW, $\overline{CS2}$ is HIGH and both \overline{LB} and \overline{UB} are HIGH, the device assumes a standby mode at which the power dissipation can be reduced down with CMOS input levels.

Easy memory expansion is provided by using Chip Enable and Output Enable inputs. The active LOW Write Enable (\overline{WE}) controls both writing and reading of the memory. A data byte allows Upper Byte (\overline{UB}) and Lower Byte (\overline{LB}) access.

The IS62/65WV12816DALL/DBLL are packaged in the JEDEC standard 48-pin mini BGA (6mm x 8mm) and 44-Pin TSOP (TYPE II).

FUNCTIONAL BLOCK DIAGRAM

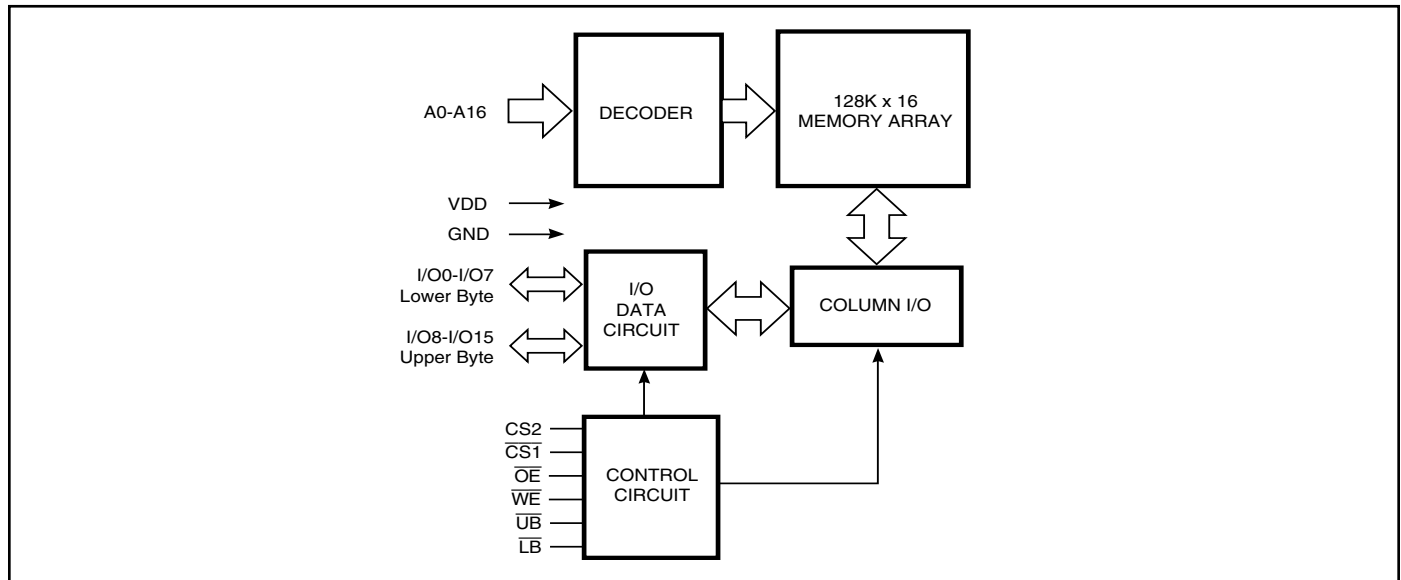

Copyright © 2013 Integrated Silicon Solution, Inc. All rights reserved. ISSI reserves the right to make changes to this specification and its products at any time without notice. ISSI assumes no liability arising out of the application or use of any information, products or services described herein. Customers are advised to obtain the latest version of this device specification before relying on any published information and before placing orders for products.

Integrated Silicon Solution, Inc. does not recommend the use of any of its products in life support applications where the failure or malfunction of the product can reasonably be expected to cause failure of the life support system or to significantly affect its safety or effectiveness. Products are not authorized for use in such applications unless Integrated Silicon Solution, Inc. receives written assurance to its satisfaction, that:

- a.) the risk of injury or damage has been minimized;
- b.) the user assume all such risks; and
- c.) potential liability of Integrated Silicon Solution, Inc is adequately protected under the circumstances

PIN CONFIGURATIONS

**48-Pin mini BGA (6mm x 8mm)
(Package Code B)**

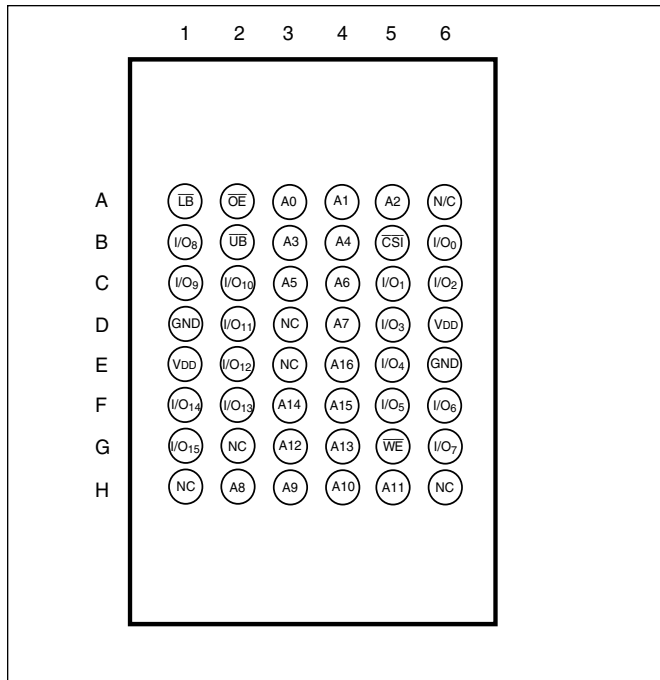

**48-Pin mini BGA (6mm x 8mm)
2 CS Option (Package Code B2)**

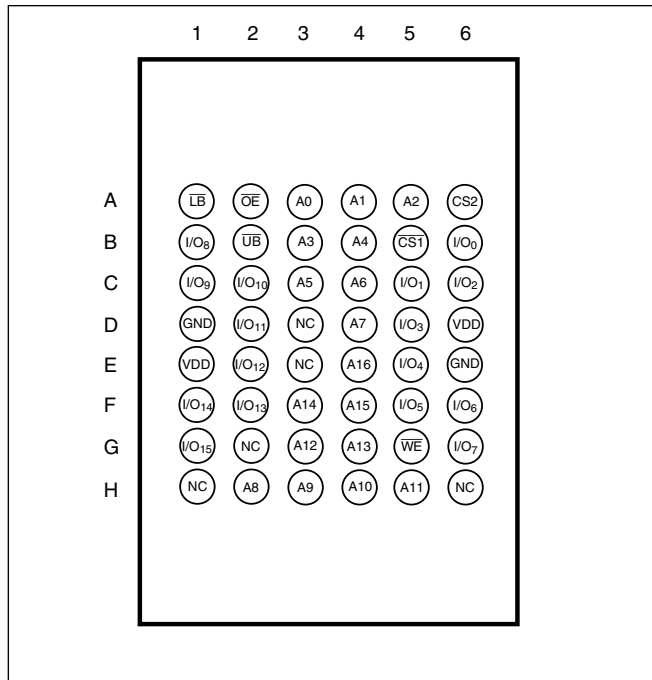

**44-Pin mini TSOP (Type II)
(Package Code T)**

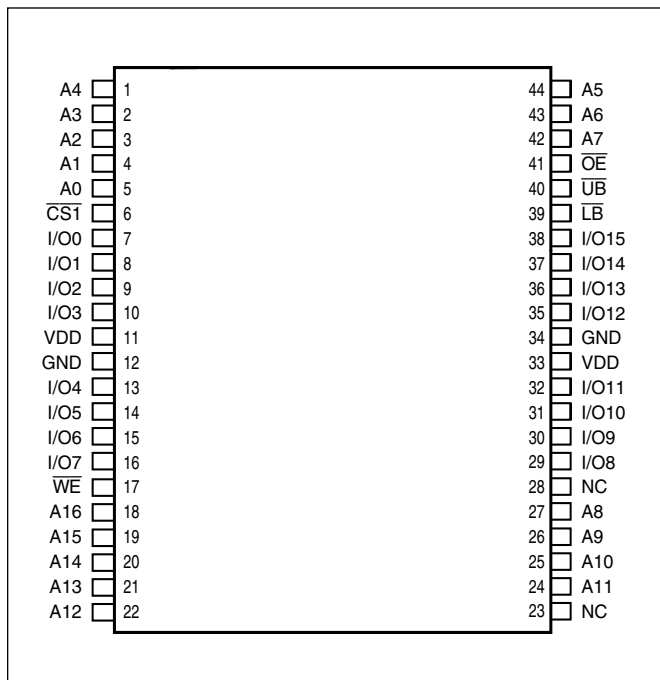

PIN DESCRIPTIONS

A0-A16	Address Inputs
I/O0-I/O15	Data Inputs/Outputs
CS1, CS2	Chip Enable Input
OE	Output Enable Input
WE	Write Enable Input
LB	Lower-byte Control (I/O0-I/O7)
UB	Upper-byte Control (I/O8-I/O15)
NC	No Connection
VDD	Power
GND	Ground

TRUTH TABLE

Mode	\overline{WE}	$\overline{CS1}$	CS2	\overline{OE}	\overline{LB}	\overline{UB}	I/O PIN		V _{DD} Current
							I/O0-I/O7	I/O8-I/O15	
Not Selected	X	H	X	X	X	X	High-Z	High-Z	I _{SB1} , I _{SB2}
	X	X	L	X	X	X	High-Z	High-Z	I _{SB1} , I _{SB2}
	X	X	X	X	H	H	High-Z	High-Z	I _{SB1} , I _{SB2}
Output Disabled	H	L	H	H	L	X	High-Z	High-Z	I _{CC}
	H	L	H	H	X	L	High-Z	High-Z	I _{CC}
Read	H	L	H	L	L	H	DOUT	High-Z	I _{CC}
	H	L	H	L	H	L	High-Z	DOUT	
	H	L	H	L	L	L	DOUT	DOUT	
Write	L	L	H	X	L	H	D _{IN}	High-Z	I _{CC}
	L	L	H	X	H	L	High-Z	D _{IN}	
	L	L	H	X	L	L	D _{IN}	D _{IN}	

ABSOLUTE MAXIMUM RATINGS⁽¹⁾

Symbol	Parameter	Value	Unit
V _{TERM}	Terminal Voltage with Respect to GND	-0.2 to V _{DD} +0.3	V
T _{STG}	Storage Temperature	-65 to +150	°C
P _T	Power Dissipation	1.0	W

Note:

1. Stress greater than those listed under ABSOLUTE MAXIMUM RATINGS may cause permanent damage to the device. This is a stress rating only and functional operation of the device at these or any other conditions above those indicated in the operational sections of this specification is not implied. Exposure to absolute maximum rating conditions for extended periods may affect reliability.

OPERATING RANGE (V_{DD})

Range	Ambient Temperature	IS62WV12816DALL	IS62WV12816DBLL
Commercial	0°C to +70°C	1.8V ± 10%	2.5V - 3.6V
Industrial	-40°C to +85°C	1.8V ± 10%	2.5V - 3.6V
		IS65WV12816DALL	IS65WV12816DBLL
Automotive	-40°C to +125°C	1.8V ± 10%	2.5V - 3.6V

DC ELECTRICAL CHARACTERISTICS (Over Operating Range)

Symbol	Parameter	Test Conditions	V _{DD}	Min.	Max.	Unit
V _{OH}	Output HIGH Voltage	I _{OH} = -0.1 mA	1.8V ± 10%	1.4	—	V
		I _{OH} = -1 mA	2.5-3.6V	2.2	—	V
V _{OL}	Output LOW Voltage	I _{OL} = 0.1 mA	1.8V ± 10%	—	0.2	V
		I _{OL} = 1.0 mA	2.5-3.6V	—	0.4	V
V _{IH}	Input HIGH Voltage		1.8V ± 10%	1.4	V _{DD} + 0.2	V
			2.5-3.6V	2.2	V _{DD} + 0.3	V
V _{IL}	Input LOW Voltage		1.8V ± 10%	-0.2	0.4	V
			2.5-3.6V	-0.2	0.6	V
I _{LI}	Input Leakage	GND ≤ V _{IN} ≤ V _{DD}		-1	1	μA
I _{LO}	Output Leakage	GND ≤ V _{OUT} ≤ V _{DD} , Outputs Disabled		-1	1	μA

Notes:

For IS62/65WV12816DALL:

V_{IL} (min.) = -1.0V AC (pluse width < 10ns). Not 100% tested.

V_{IH} (max.) = V_{DD} + 1.0V AC; (pluse width < 10ns). Not 100% tested.

For IS62/65WV12816DBLL:

V_{IL} (min.) = -2.0V AC (pluse width < 10ns). Not 100% tested.

V_{IH} (max.) = V_{DD} + 2.0V AC; (pluse width < 10ns). Not 100% tested.

CAPACITANCE⁽¹⁾

Symbol	Parameter	Conditions	Max.	Unit
C _{IN}	Input Capacitance	V _{IN} = 0V	8	pF
C _{OUT}	Input/Output Capacitance	V _{OUT} = 0V	10	pF

Note:

1. Tested initially and after any design or process changes that may affect these parameters.

IS62WV12816DALL/DBLL, IS65WV12816DALL/DBLL

IS62/65WV12816DALL, POWER SUPPLY CHARACTERISTICS⁽¹⁾ (Over Operating Range)

Symbol	Parameter	Test Conditions		Max.	Unit
I _{CC}	V _{DD} Dynamic Operating Supply Current	V _{DD} = Max., I _{OUT} = 0 mA, f = f _{MAX}	Com.	15	mA
			Ind.	20	
			Auto.	25	
I _{CC1}	Operating Supply Current	V _{DD} = Max., I _{OUT} = 0 mA, f = 0	Com.	3	mA
			Ind.	3	
			Auto.	4	
I _{SB1}	TTL Standby Current (TTL Inputs)	CS ₂ = V _{IL} f = 0Hz	Com.	0.3	mA
			Ind.	0.3	
			Auto.	0.5	
I _{SB2}	CMOS Standby Current (CMOS Inputs)	(1) 0V ≤ CS ₂ ≤ 0.2V OR	Com.	4	μA
		(2) $\overline{CS1} \geq V_{DD} - 0.2V$, CS ₂ ≥ V _{DD} - 0.2V OR	Ind.	6	
		(3) \overline{LB} and $\overline{UB} \geq V_{DD} - 0.2V$ $\overline{CS1} \leq 0.2V$, CS ₂ ≥ V _{DD} - 0.2V, f = 0Hz	Auto.	15	

IS62/65WV12816DBLL, POWER SUPPLY CHARACTERISTICS⁽¹⁾ (Over Operating Range)

Symbol	Parameter	Test Conditions		Max	Max.	Max.	Unit
				35	45	55	
I _{CC}	V _{DD} Dynamic Operating Supply Current	V _{DD} = Max., I _{OUT} = 0 mA, f = f _{MAX}	Com.	22	20	18	mA
			Ind.	23	21	19	
			Auto.	35	30	25	
			typ. ⁽²⁾	15	12	10	
I _{CC1}	Operating Supply Current	V _{DD} = Max., I _{OUT} = 0 mA, f = 0	Com.	3	3	3	mA
			Ind.	3	3	3	
			Auto.	4	4	4	
I _{SB1}	TTL Standby Current (TTL Inputs)	CS ₂ = VIL f = 0Hz	Com.	0.2	0.2	0.2	mA
			Ind.	0.2	0.2	0.2	
			AUTO.	0.3	0.3	0.3	
I _{SB2}	CMOS Standby Current (CMOS Inputs)	(1) 0V ≤ CS ₂ ≤ 0.2V OR	Com.	5	5	5	μA
			Ind.	7	7	7	
		(2) $\overline{CS1} \geq VDD - 0.2V$, CS ₂ ≥ VDD - 0.2V OR	Auto.	25	25	25	
			typ. ⁽²⁾	2	2	2	
		(3) \overline{LB} and $\overline{UB} > VDD - 0.2V$ $\overline{CS1} \leq 0.2V$, CS ₂ ≥ VDD - 0.2V f = 0Hz					

Note:

- At f = f_{MAX}, address and data inputs are cycling at the maximum frequency, f = 0 means no input lines change.
- Typical values are measured at V_{DD} = 3.0V, T_A = 25°C and not 100% tested.

AC TEST CONDITIONS

Parameter	IS62/65WV12816DALL (Unit)	IS62/65WV12816DBLL (Unit)
Input Pulse Level	0.4V to $V_{DD}-0.2V$	0.4V to $V_{DD}-0.3V$
Input Rise and Fall Times	1V/1ns	1V/1ns
Input and Output Timing and Reference Level	V_{REF}	V_{REF}
Output Load	See Figures 1 and 2	See Figures 1 and 2

	1.8V ± 10%	2.5V - 3.6V
R1 (Ω)	3070	3070
R2 (Ω)	3150	3150
V_{REF}	0.9V	1.5V
V_{TM}	1.8V	2.8V

AC TEST LOADS

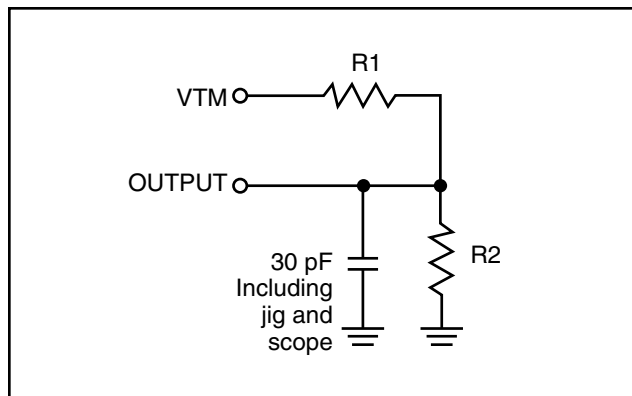

Figure 1

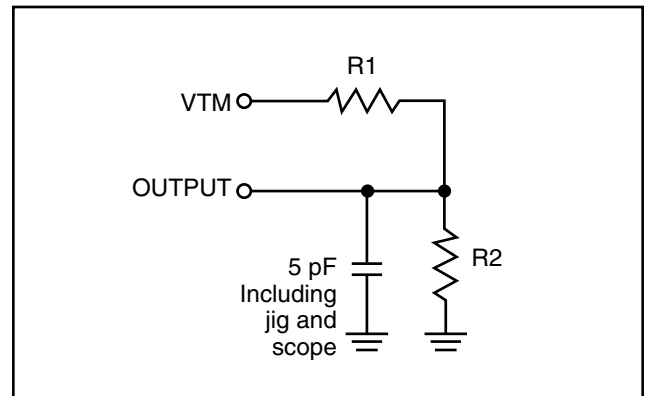

Figure 2

READ CYCLE SWITCHING CHARACTERISTICS⁽¹⁾ (Over Operating Range)

Symbol	Parameter	35 ns		45 ns		55 ns		Unit
		Min.	Max.	Min.	Max.	Min.	Max.	
t _{RC}	Read Cycle Time	35	—	45	—	55	—	ns
t _{AA}	Address Access Time	—	35	—	45	—	55	ns
t _{OHA}	Output Hold Time	10	—	10	—	10	—	ns
t _{ACS1} /t _{ACS2}	$\overline{CS1}/\overline{CS2}$ Access Time	—	35	—	45	—	55	ns
t _{DOE}	\overline{OE} Access Time	—	15	—	20	—	25	ns
t _{HZOE} ⁽²⁾	\overline{OE} to High-Z Output	—	10	—	15	—	20	ns
t _{LZOE} ⁽²⁾	\overline{OE} to Low-Z Output	5	—	5	—	5	—	ns
t _{HZCS1} /t _{HZCS2} ⁽²⁾	$\overline{CS1}/\overline{CS2}$ to High-Z Output	0	10	0	15	0	20	ns
t _{LZCS1} /t _{LZCS2} ⁽²⁾	$\overline{CS1}/\overline{CS2}$ to Low-Z Output	10	—	10	—	10	—	ns
t _{BA}	$\overline{LB}, \overline{UB}$ Access Time	—	35	—	45	—	55	ns
t _{HZB}	$\overline{LB}, \overline{UB}$ to High-Z Output	0	10	0	15	0	20	ns
t _{LZB}	$\overline{LB}, \overline{UB}$ to Low-Z Output	0	—	0	—	0	—	ns

Notes:

1. Test conditions and output loading conditions are specified in the AC Test Conditions and AC Test Loads (Figure 1).
2. Tested with the load in Figure 2. Transition is measured ± 500 mV from steady-state voltage. Not 100% tested.

AC WAVEFORMS

READ CYCLE NO. 1^(1,2) (Address Controlled) ($\overline{CS1} = \overline{OE} = V_{IL}$, $CS2 = \overline{WE} = V_{IH}$, \overline{UB} or $\overline{LB} = V_{IL}$)

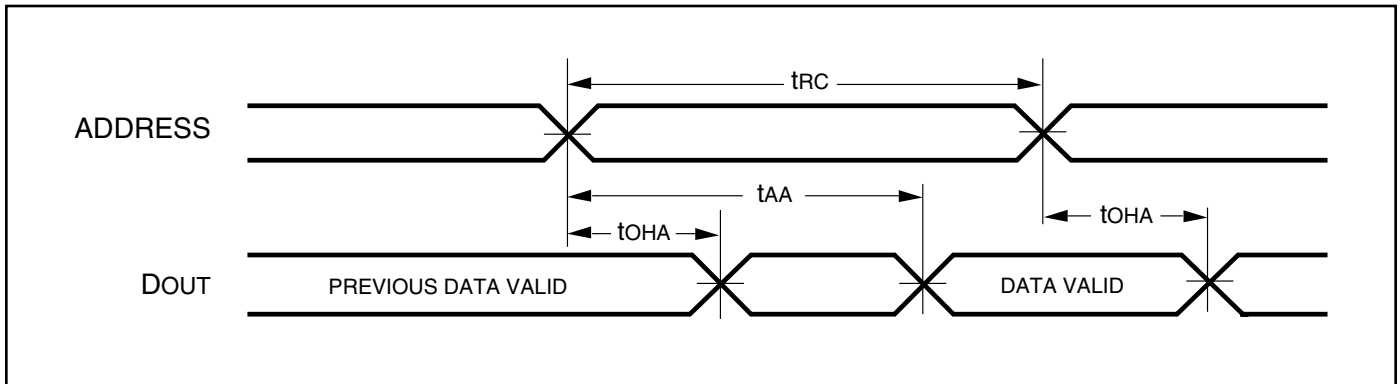

AC WAVEFORMS

READ CYCLE NO. 2^(1,3) ($\overline{CS1}$, $CS2$, \overline{OE} , AND $\overline{UB}/\overline{LB}$ Controlled)

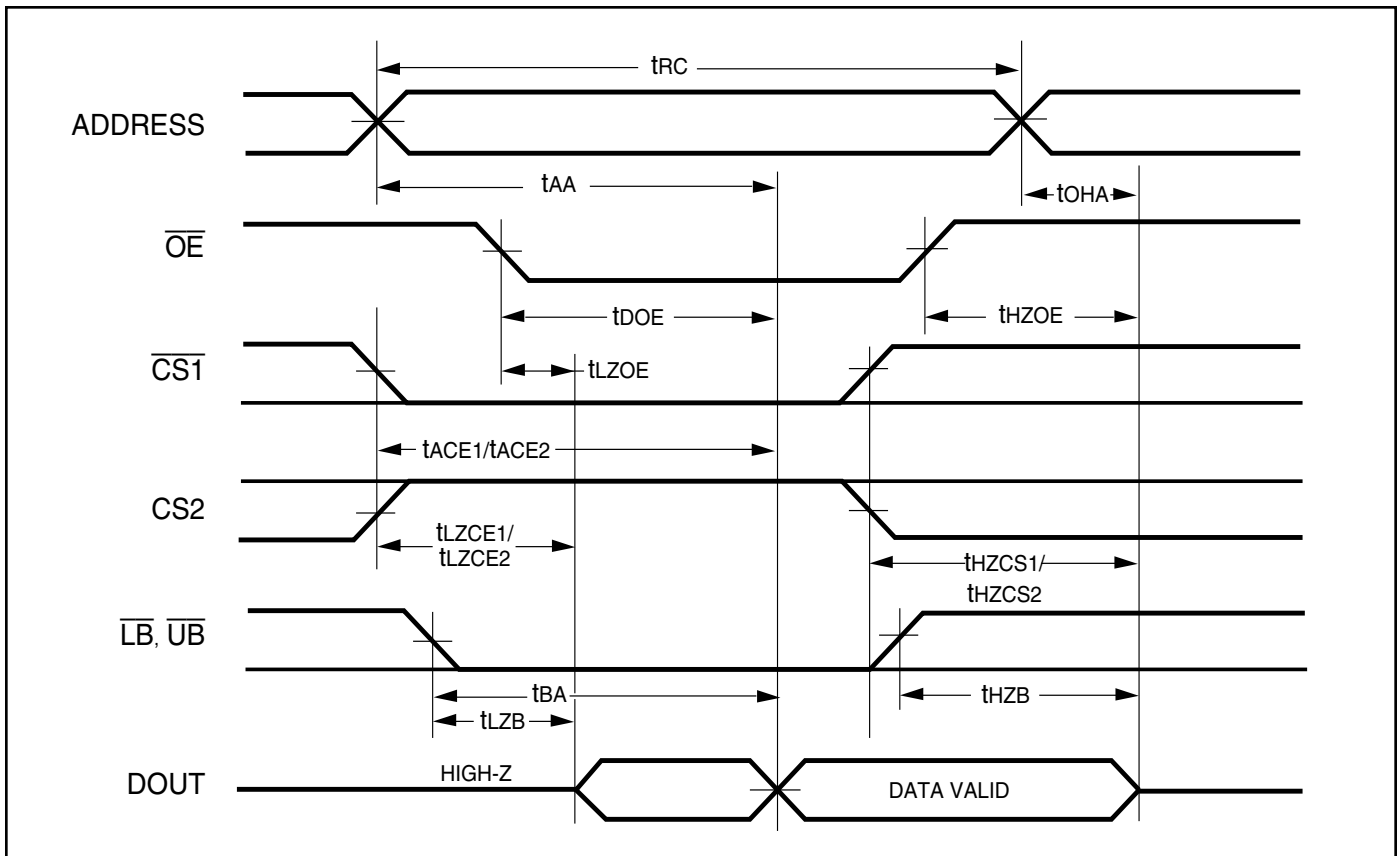

Notes:

1. \overline{WE} is HIGH for a Read Cycle.
2. The device is continuously selected. \overline{OE} , $\overline{CS1}$, \overline{UB} , or $\overline{LB} = V_{IL}$. $CS2 = \overline{WE} = V_{IH}$.
3. Address is valid prior to or coincident with $\overline{CS1}$ LOW transition.

WRITE CYCLE SWITCHING CHARACTERISTICS^(1,2) (Over Operating Range)

Symbol	Parameter	35 ns		45 ns		55 ns		Unit
		Min.	Max.	Min.	Max.	Min.	Max.	
t _{WC}	Write Cycle Time	35	—	45	—	55	—	ns
t _{SCS1} /t _{SCS2}	$\overline{CS1}$ / $\overline{CS2}$ to Write End	25	—	35	—	45	—	ns
t _{AW}	Address Setup Time to Write End	25	—	35	—	45	—	ns
t _{HA}	Address Hold from Write End	0	—	0	—	0	—	ns
t _{SA}	Address Setup Time	0	—	0	—	0	—	ns
t _{PWB}	\overline{LB} , \overline{UB} Valid to End of Write	30	—	35	—	45	—	ns
t _{PWE}	\overline{WE} Pulse Width	30	—	35	—	40	—	ns
t _{SD}	Data Setup to Write End	15	—	20	—	25	—	ns
t _{HD}	Data Hold from Write End	0	—	0	—	0	—	ns
t _{HZWE} ⁽³⁾	\overline{WE} LOW to High-Z Output	—	20	—	20	—	20	ns
t _{LZWE} ⁽³⁾	\overline{WE} HIGH to Low-Z Output	5	—	5	—	5	—	ns

Notes:

1. Test conditions and output loading conditions are specified in the AC Test Conditions and AC Test Loads (Figure 1).
2. The internal write time is defined by the overlap of $\overline{CS1}$ LOW, $\overline{CS2}$ HIGH and \overline{UB} or \overline{LB} , and \overline{WE} LOW. All signals must be in valid states to initiate a Write, but any one can go inactive to terminate the Write. The Data Input Setup and Hold timing are referenced to the rising or falling edge of the signal that terminates the write.
3. Tested with the load in Figure 2. Transition is measured ± 500 mV from steady-state voltage. Not 100% tested.

AC WAVEFORMS

WRITE CYCLE NO. 1^(1,2) ($\overline{CS1}$ Controlled, \overline{OE} = HIGH or LOW)

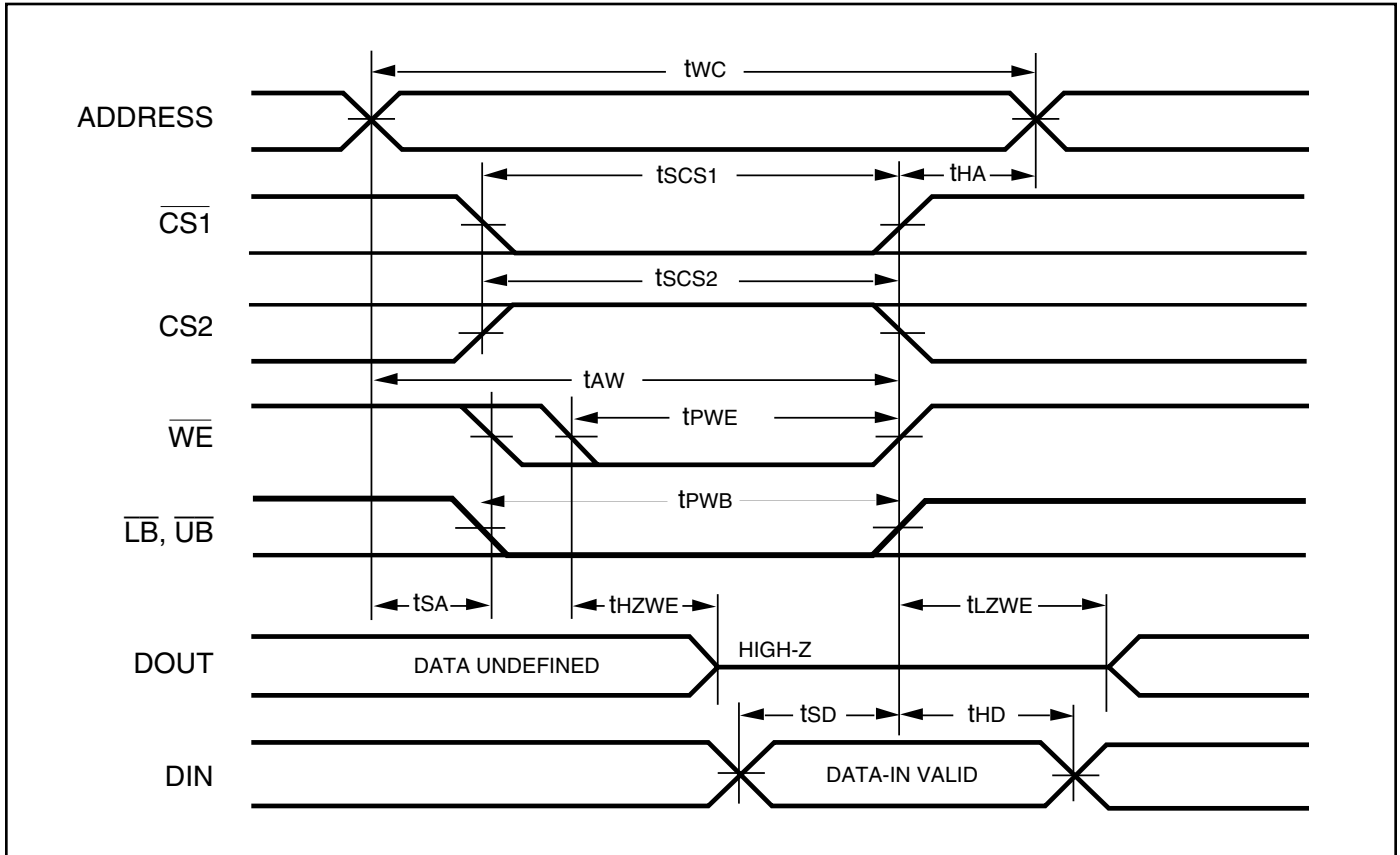

Notes:

1. WRITE is an internally generated signal asserted during an overlap of the LOW states on the $\overline{CS1}$, CS2 and \overline{WE} inputs and at least one of the \overline{LB} and \overline{UB} inputs being in the LOW state.
2. $WRITE = (\overline{CS1}) [(\overline{LB}) = (\overline{UB})] (\overline{WE})$.

AC WAVEFORMS

WRITE CYCLE NO. 2 (\overline{WE} Controlled: \overline{OE} is HIGH During Write Cycle)

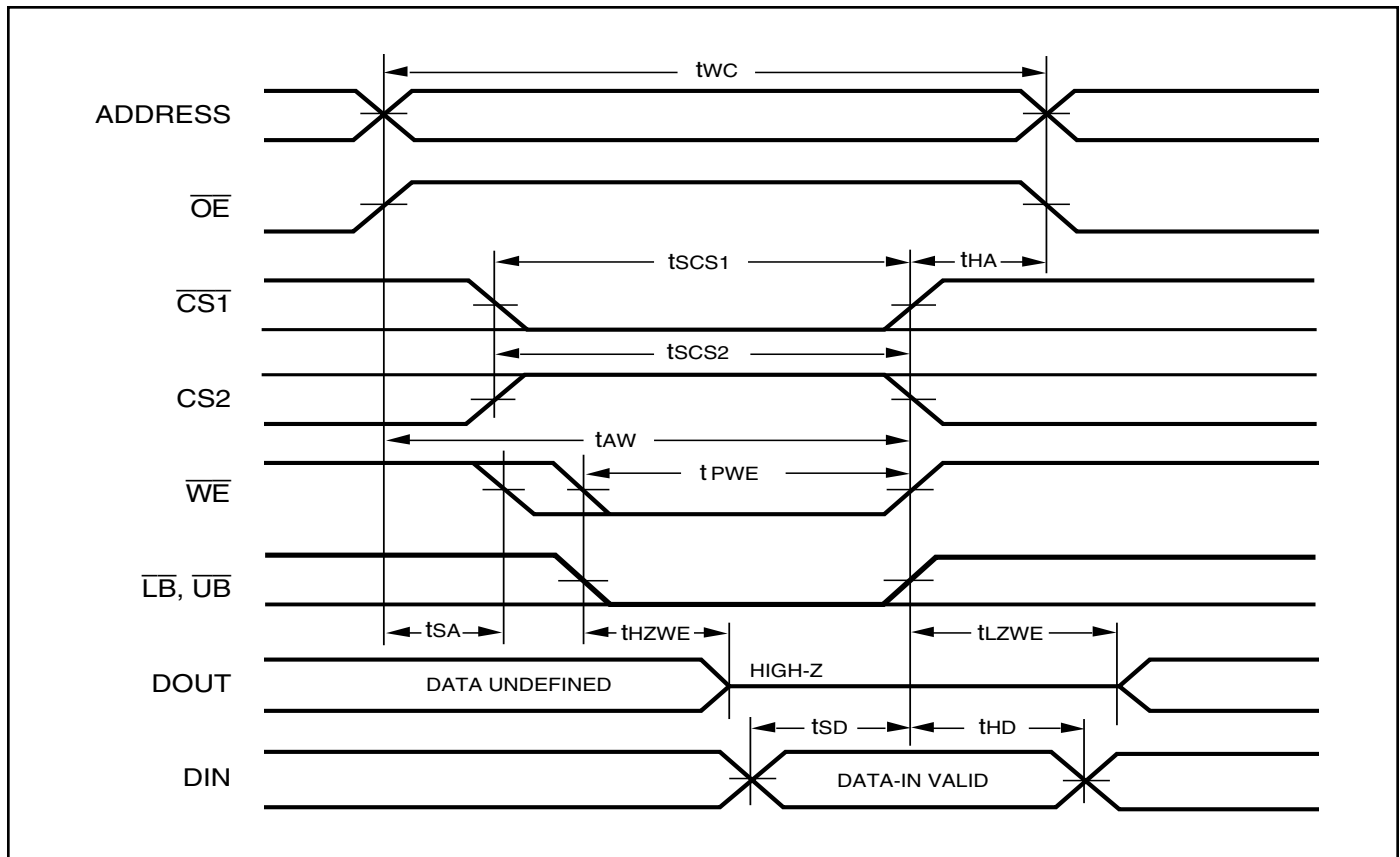

AC WAVEFORMS

WRITE CYCLE NO. 3 (\overline{WE} Controlled: \overline{OE} is LOW During Write Cycle)

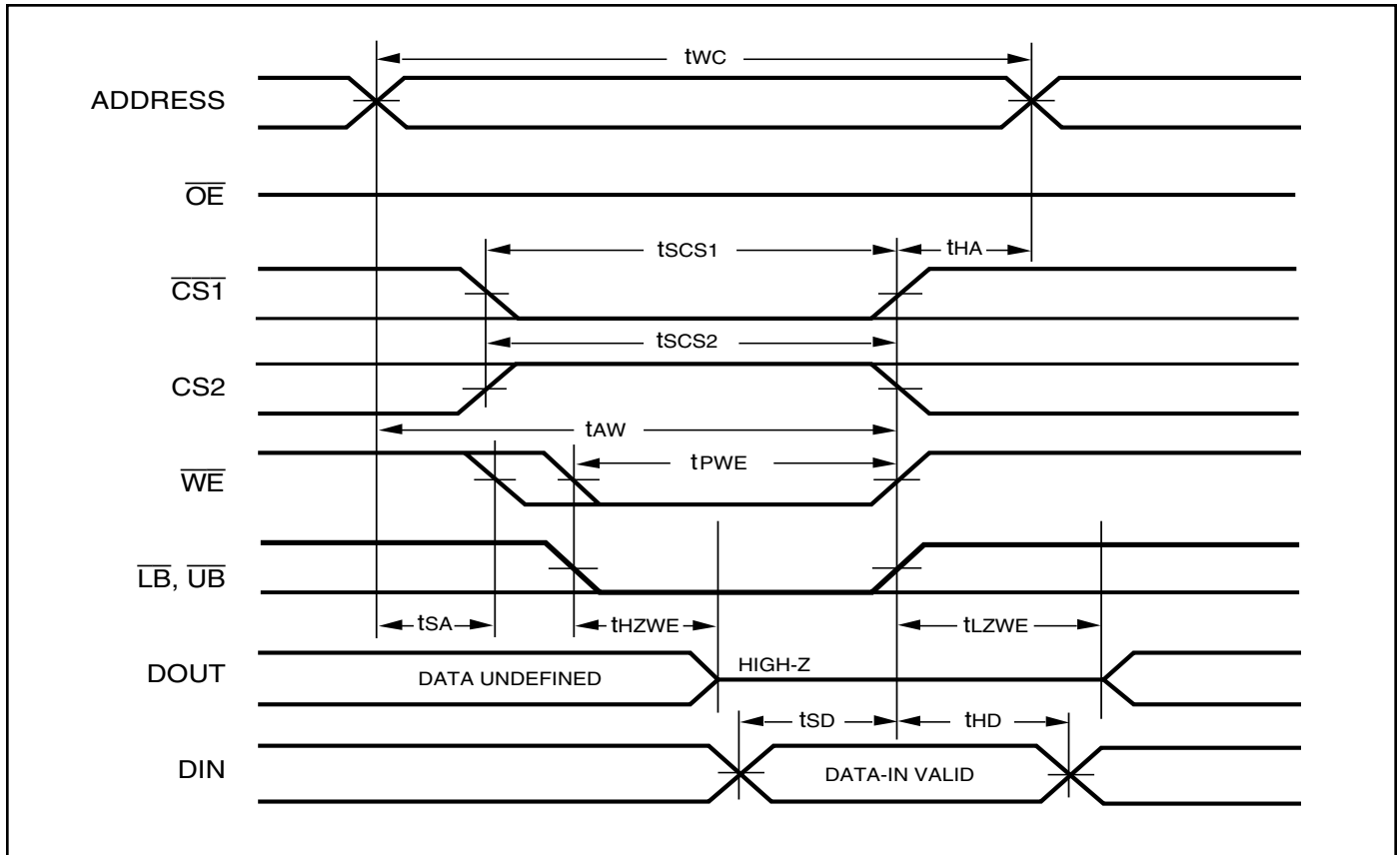

AC WAVEFORMS

WRITE CYCLE NO. 4 ($\overline{UB}/\overline{LB}$ Controlled)

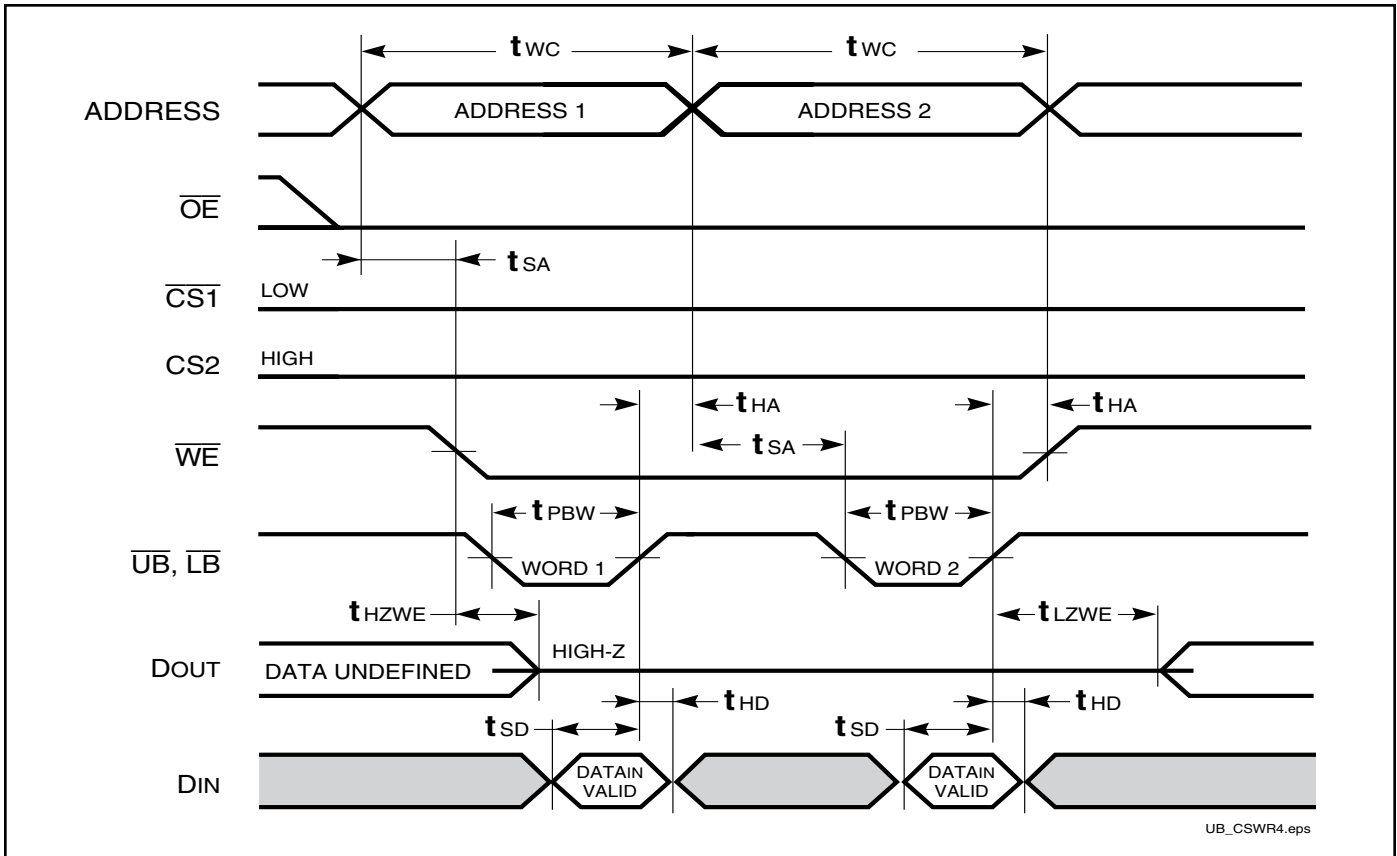

DATA RETENTION SWITCHING CHARACTERISTICS

Symbol	Parameter	Test Condition	Min.	Max.	Unit
V _{DR}	V _{DD} for Data Retention	See Data Retention Waveform	1.5	3.6	V
I _{DR}	Data Retention Current	V _{DD} = V _{DR} (min), (1) 0V ≤ CS2 ≤ 0.2V, or (2) CS1 ≥ V _{DD} - 0.2V, CS2 ≥ V _{DD} - 0.2V or (3) LB and UB ≥ V _{DD} - 0.2V, CS1 ≤ 0.2V, CS2 ≥ V _{DD} - 0.2V	Com. Ind. Auto. typ. ⁽²⁾	— — — 2	4 6 20 μA
t _{SDR}	Data Retention Setup Time	See Data Retention Waveform	0	—	ns
t _{RDR}	Recovery Time	See Data Retention Waveform	t _{RC}	—	ns

Note:

1. Typical values are measured at V_{DD} = V_{DR}(min), T_A = 25°C and not 100% tested.

DATA RETENTION WAVEFORM (CS2 Controlled)

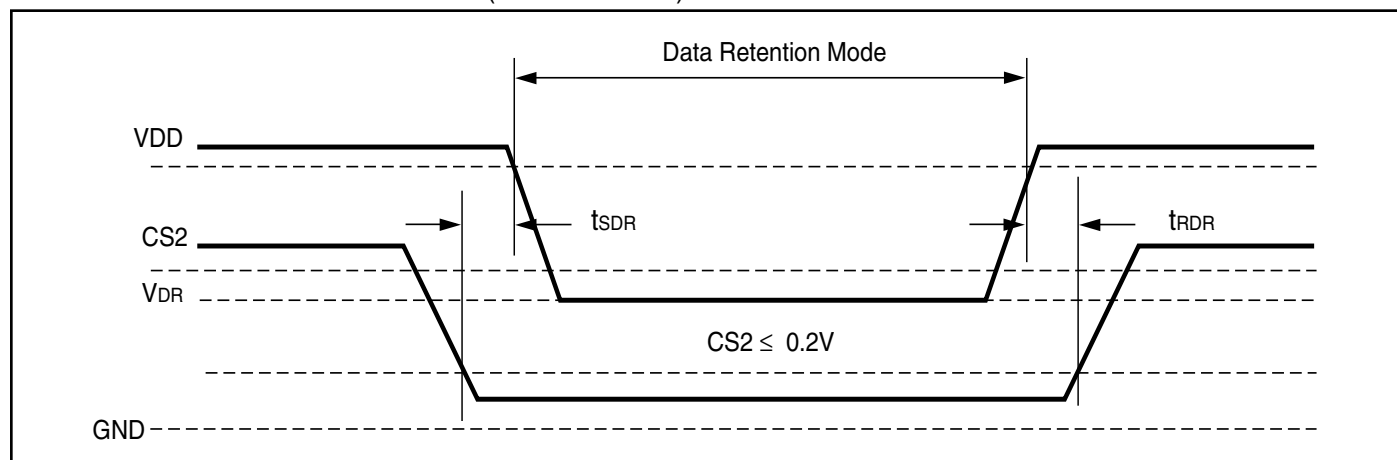

DATA RETENTION WAVEFORM (CS1Controlled)

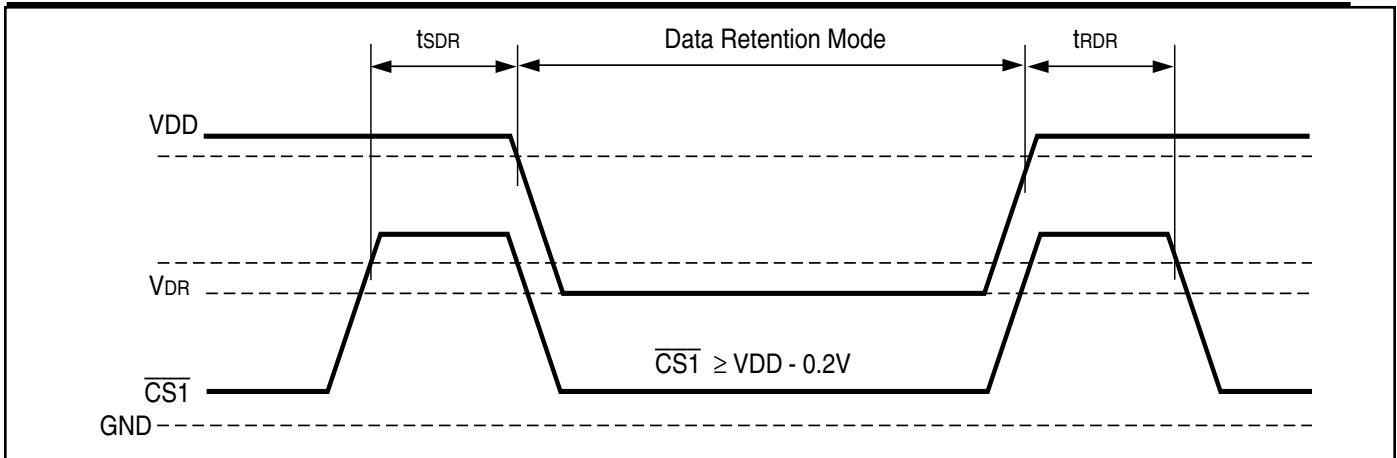

Note:

1. CS2 must satisfy either $CS2 \geq Vcc - 0.2V$ or $CS2 \leq 0.2V$

DATA RETENTION WAVEFORM (\overline{UB} and \overline{LB} Controlled)

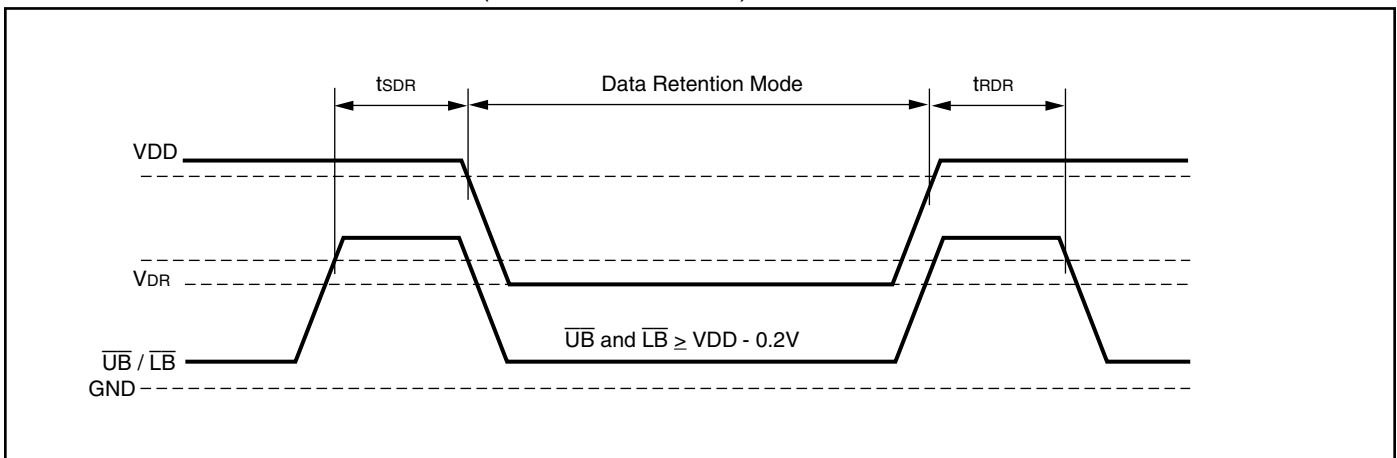

Note:

1. CS2 must satisfy either $CS2 \geq Vcc - 0.2V$ or $CS2 \leq 0.2V$
2. $\overline{CS1}$ must satisfy either $CS1 \geq Vcc - 0.2V$ or $CS1 \leq 0.2V$

ORDERING INFORMATION: IS62WV12816DALL (1.65V - 2.2V)**Industrial Range: -40°C to +85°C**

Speed (ns)	Order Part No.	Package
55	IS62WV12816DALL-55TI	TSOP (Type II)
	IS62WV12816DALL-55BI	mini BGA (6mm x 8mm)
	IS62WV12816DALL-55BLI	mini BGA (6mm x 8mm), Lead-free
	IS62WV12816DALL-55B2I	mini BGA (6mm x 8mm), 2 CS Option

ORDERING INFORMATION: IS62WV12816DBLL (2.5V - 3.6V)**Industrial Range: -40°C to +85°C**

Speed (ns)	Order Part No.	Package
35	IS62WV12816DBLL-35TLI	TSOP (Type II), Lead-free
	IS62WV12816DBLL-35BLI	mini BGA (6mm x 8mm), Lead-free
	IS62WV12816DBLL-35B2LI	mini BGA (6mm x 8mm), 2 CS Option, Lead-free
45	IS62WV12816DBLL-45TLI	TSOP (Type II), Lead-free
	IS62WV12816DBLL-45BLI	mini BGA (6mm x 8mm), Lead-free
	IS62WV12816DBLL-45B2LI	mini BGA (6mm x 8mm), 2 CS Option, Lead-free
55	IS62WV12816DBLL-55TI	TSOP (Type II)
	IS62WV12816DBLL-55TLI	TSOP (Type II), Lead-free
	IS62WV12816DBLL-55BI	mini BGA (6mm x 8mm)
	IS62WV12816DBLL-55BLI	mini BGA (6mm x 8mm), Lead-free
	IS62WV12816DBLL-55B2I	mini BGA (6mm x 8mm), 2 CS Option
	IS62WV12816DBLL-55B2LI	mini BGA (6mm x 8mm), 2 CS Option, Lead-free

ORDERING INFORMATION: IS65WV12816DBLL (2.5V - 3.6V)**Automotive Range (A3): -40°C to +125°C**

Speed (ns)	Order Part No.	Package
45	IS65WV12816DBLL-45CTLA3	TSOP (Type II), Lead-free, Copper Leadframe
	IS65WV12816DBLL-45BLA3	mini BGA (6mm x 8mm), Lead-free

TOP VIEW

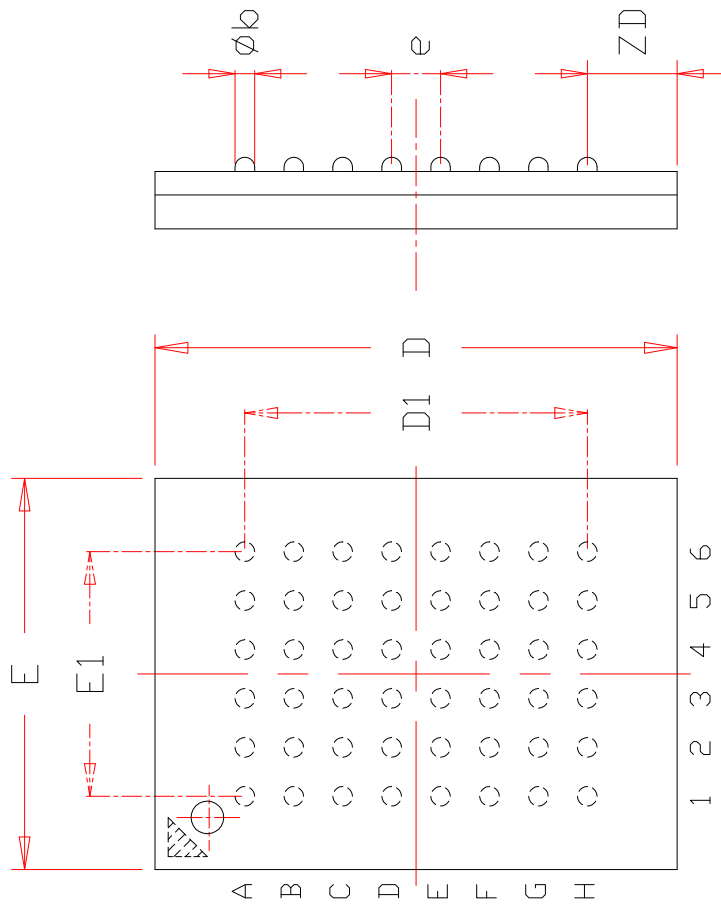

NOTE :

1. CONTROLLING DIMENSION : MM .
2. Reference document : JEDEC MO-207

SYMBOL	DIMENSION IN MM			DIMENSION IN INCH		
	MIN.	NOM.	MAX.	MIN.	NOM.	MAX.
A			1.20			0.047
A1	0.20		0.30	0.008		0.012
ϕb	0.30	0.35	0.40	0.012	0.014	0.016
D	7.90	8.00	8.10	0.311	0.315	0.319
D1	5.25 BSC			0.207 BSC		
E	5.90	6.00	6.10	0.232	0.236	0.240
E1	3.75 BSC			0.148 BSC		
e	0.75 BSC.			0.030 BSC.		
ZD	1.375 REF.			0.054 REF.		
ZE	1.125 REF.			0.044 REF.		

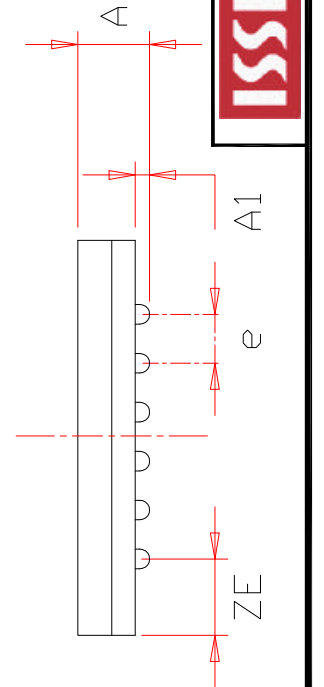

TITLE

48L 6x8mm TF-BGA
Package Outline

REV.

C

DATE

08/12/2008

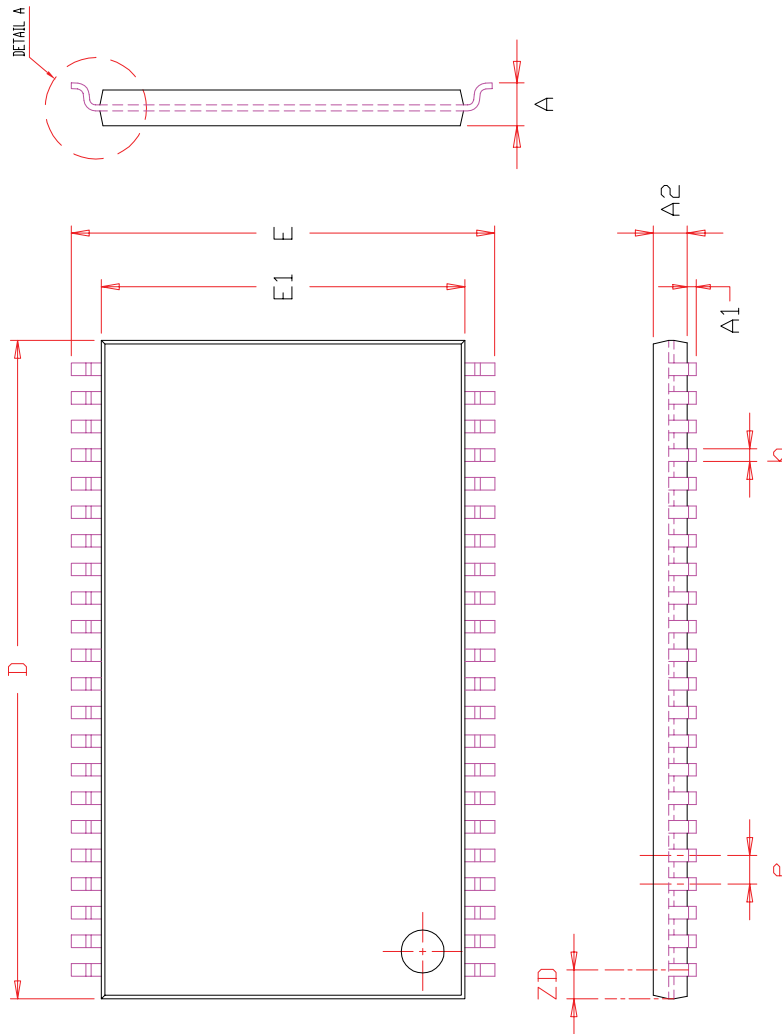

SYMBOL	DIMENSION IN MM			DIMENSION IN INCH		
	MIN.	NOM.	MAX.	MIN.	NOM.	MAX.
A	1.00		1.20	0.039		0.047
A1	0.05		0.15	0.002		0.006
A2	0.95	1.00	1.05	0.037	0.039	0.041
b	0.30		0.45	0.012		0.018
D	18.28	18.41	18.54	0.720	0.725	0.730
E	11.56	11.76	11.96	0.455	0.463	0.471
E1	10.03	10.16	10.29	0.395	0.400	0.405
e	0.80	BSC.		0.031	BSC.	
L	0.40		0.69	0.016		0.027
L1	0.25	BSC.		0.010	BSC.	
ZD	0.805	REF.		0.032	REF.	
⊕	0		8°	0		8°

NOTE :

1. CONTROLLING DIMENSION : MM
2. DIMENSION D AND E1 DO NOT INCLUDE MOLD PROTRUSION.
3. DIMENSION b DOES NOT INCLUDE DAMBAR PROTRUSION/INTRUSION.

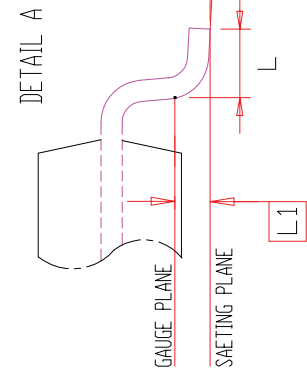

44L 400mil TSOP-2
Package Outline

F

REV.

DATE

06/04/2008

Looking for pricing, stock, or lifecycle information?

Click below to explore more details on WIN SOURCE:

-  [View IS62WV12816DBLL-45BLI on WIN SOURCE](#)
-  [ISSI, Integrated Silicon Solution Inc Information](#)

Optimize Your Supply Chain with WIN SOURCE Solutions

-  Global Sourcing Solution
-  Obsolete Management
-  Cost Control Management
-  Shortage Management
-  Alternative Solution
-  Excess Inventory Management