



**THE DATASHEET OF
PMA2-43LN+**





ULTRA LOW NOISE, HIGH IP3

Monolithic Amplifier

PMA2-43LN+

50Ω 1.1 to 4.0 GHz

THE BIG DEAL

- Ultra low noise figure, 0.46 dB typ. at 1.9 GHz
- High IP3, +33 dBm typ. at 1.9 GHz
- High Pout, P1dB +19.9 dBm typ. at 1.9 GHz
- Small size, 2 x 2 x 1mm

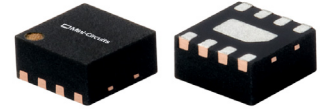

Generic photo used for illustration purposes only

CASE STYLE: MC1631-1

+RoHS Compliant

The +Suffix identifies RoHS Compliance. See our website for methodologies and qualifications

APPLICATIONS

- Base station infrastructure
- Portable Wireless
- LTE
- GPS
- GSM
- Airborne radar

PRODUCT OVERVIEW

Mini-Circuits PMA2-43LN+ is an E-PHEMT* based, ultra-low noise MMIC amplifier with a unique combination of low noise and high IP3, making this amplifier ideal for sensitive, high-dynamic-range receiver applications. This design operates on a single +5V supply, is well matched for 50Ω systems, and comes in a tiny, low profile package, accommodating dense circuit board layouts.

KEY FEATURES

Feature	Advantages
Ultra-low noise, 0.46 dB at 1.9 GHz	Enables lower system noise figure performance
High IP3 <ul style="list-style-type: none"> • +32.9 dBm at 1.9 GHz • +32.6 dBm at 2.5 GHz 	Combination of low noise and high IP3 makes this MMIC amplifier ideal for use in low noise receiver front end (RFE) as it gives the user advantages of sensitivity & two-tone IM performance at both ends of the dynamic range.
Low operating voltage, +5V	Achieves high IP3 using low voltage.
2 x 2mm 8-lead MCLP package	Tiny footprint saves space in dense layouts while providing low inductance, repeatable transitions, and excellent thermal contact to the PCB.
High max input power <ul style="list-style-type: none"> • +22 dBm (5 minutes) • +14 dBm (continuous) 	Ruggedized design provides high power handling for input powers common at receiver inputs, eliminating the need for an external limiter in most cases.
High reliability	Low signal operating current of 51 mA nominal maintains junction temperatures typically below 103 °C at 85°C ground lead temperature.

*Enhancement mode Pseudomorphic High Electron Mobility Transistor





ULTRA LOW NOISE, HIGH IP3

Monolithic Amplifier

PMA2-43LN+

50Ω 1.1 to 4.0 GHz

ELECTRICAL SPECIFICATIONS¹ AT +25°C AND +5V, UNLESS NOTED OTHERWISE

Parameter	Condition (GHz)	Min.	Typ.	Max.	Units
Frequency Range		1.1		4.0	GHz
Noise Figure	1.1		0.41	—	dB
	1.5		0.45	—	
	1.9		0.46	0.69	
	2.5		0.66	—	
	4.0		1.08	—	
Gain	1.1	—	23.4	—	dB
	1.5	—	21.6	—	
	1.9	18.0	19.9	22.01	
	2.5	—	17.6	—	
	4.0	—	12.9	—	
Input Return Loss	1.1		13.8		dB
	1.5		19.1		
	1.9		16.6		
	2.5		14.1		
	4.0		11.9		
Output Return Loss	1.1		9.6		dB
	1.5		11.9		
	1.9		12.3		
	2.5		10.6		
	4.0		6.7		
Output Power at 1dB Compression	1.1		+18.6		dBm
	1.5		+19.4		
	1.9		+19.9		
	2.5		+19.7		
	4.0		+17.1		
Output IP3	1.1		+30.3		dBm
	1.5		+32.3		
	1.9		+32.9		
	2.5		+32.6		
	4.0		+32.2		
Device Operating Voltage (V_{DD})			+5.0		V
Device Operating Current (I_{DD})			51	64	mA
Device Current Variation vs. Temperature ²			-72		$\mu\text{A}/^\circ\text{C}$
Device Current Variation vs. Voltage			0.018		mA/mV
Thermal Resistance, junction-to-ground lead			61		$^\circ\text{C}/\text{W}$

1. Measured on Mini-Circuits Characterization test board TB-805+. See Characterization Test Circuit (Fig. 1)

2. Current increases at P1dB

3. (Current at 85°C - Current at -45°C)/130





ULTRA LOW NOISE, HIGH IP3

Monolithic Amplifier

PMA2-43LN+

50Ω 1.1 to 4.0 GHz

ABSOLUTE MAXIMUM RATINGS⁴

Parameter	Ratings
Operating Temperature (ground lead)	-40°C to +85°C
Storage Temperature	-65°C to +150°C
Junction Temperature	+150°C
Total Power Dissipation	0.7 W
Input Power (CW), Vd=5V ⁵	+22 dBm (5minutes max) +14 dBm (continuous)
DC Voltage	+6V

4. Permanent damage may occur if any of these limits are exceeded. Electrical maximum ratings are not intended for continuous normal operation.

5. Measured on Mini-Circuits test board, TB-805+

SIMPLIFIED SCHEMATIC & PAD DESCRIPTION

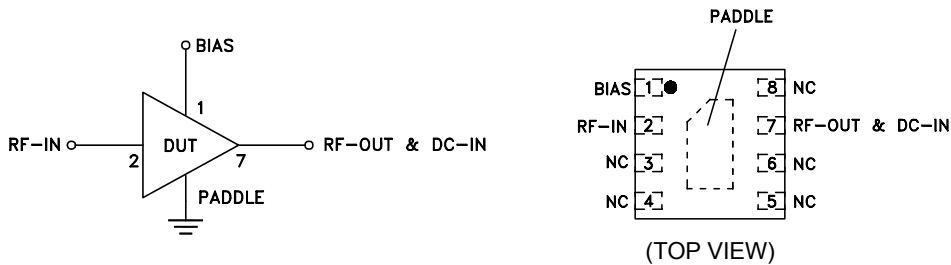

Function	Pad Number	Description (See Figure 1)
RF-IN	2	Connects to RF input via C1 and Pad 1 via L1
RF-OUT & DC-IN	7	Connects to RF out via C2 and V _s via L2 & R2
Ground	Paddle	Connects to ground
Bias	1	Connects to Supply voltage (V _s) via R1 & Rb
No Connection	3,4,5,6,8	Not used internally. Connected to ground on test board



ULTRA LOW NOISE, HIGH IP3

Monolithic Amplifier

PMA2-43LN+

50Ω 1.1 to 4.0 GHz

RECOMMENDED APPLICATION AND CHARACTERIZATION TEST CIRCUIT

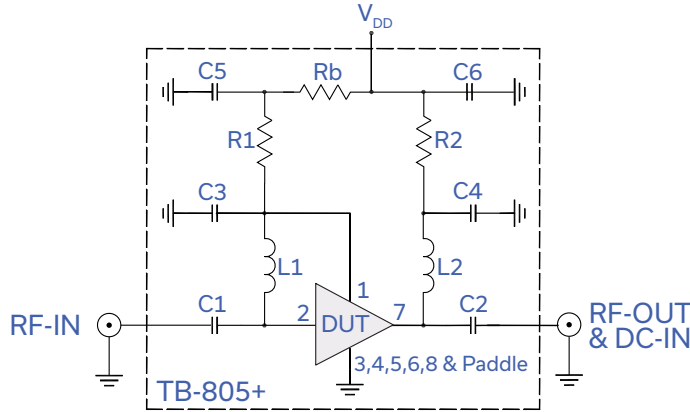

Component	Value	Size
C1, C2	1000pF	0402
C5, C6	4.7μF	0402
C3, C4	100pF	0402
L1	10nH	0402
L2	8.2nH	0402
R1	49.9Ω	0402
R2	0Ω	0603
Rb	5.11kΩ	0402

Fig 1. Application and Characterization Circuit

Note: This block diagram is used for characterization. (DUT soldered on Mini-Circuits Characterization test board TB-805+) Gain, Return loss, Output power at 1dB compression (P1 dB), output IP3 (OIP3) and noise figure measured using Agilent's N5242A PNA-X microwave network analyzer.

Conditions:

1. Gain and Return loss: Pin= -25dBm
2. Output IP3 (OIP3): Two tones, spaced 1 MHz apart, 0 dBm/tone at output.

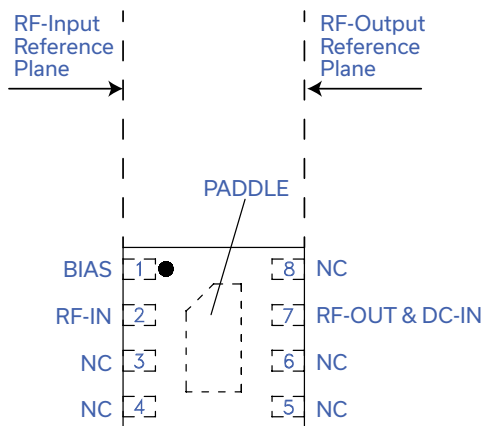

NOISE PARAMETERS^{6,7,8} (AT 50 mA)

Frequency (MHz)	Fmin (dB)	Γ_{opt} Magnitude	Γ_{opt} Angle	Rn/50
800	0.26	0.066	79.6	0.039
900	0.22	0.086	98.2	0.032
1000	0.22	0.108	102.9	0.032
1500	0.25	0.214	135.0	0.021
2000	0.27	0.237	-169.4	0.028
2500	0.32	0.317	-162.8	0.022
3000	0.43	0.381	-141.7	0.035

6. DUT soldered on test board (50 ohm input and output)

7. Reference plane is at the end of the RF-IN pad and the output reference plane is at the end of the RF-OUT pad as shown in figure below

8. For data at 40,60,70 & 80 mA, data can be found in S-parameter files and can be downloaded from model dash-board.

PRODUCT MARKING

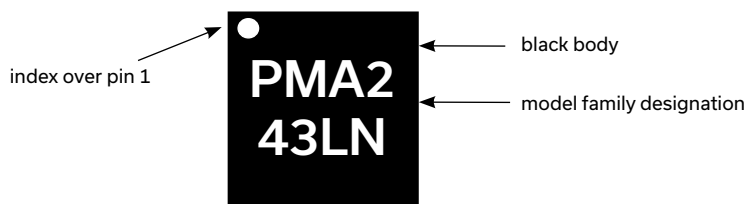

Marking may contain other features or characters for internal lot control





ULTRA LOW NOISE, HIGH IP3

Monolithic Amplifier

PMA2-43LN+

50Ω 1.1 to 4.0 GHz

ADDITIONAL DETAILED TECHNICAL INFORMATION IS AVAILABLE ON OUR DASH BOARD. TO ACCESS [CLICK HERE](#)

Performance Data	Data Table Swept Graphs S-Parameter (S2P Files) Data Set (.zip file)
Case Style	MC1631-1 Plastic package, exposed paddle, lead finish: Matte-Tin
Tape & Reel	F66
Standard quantities available on reel	7" reels with 20, 50, 100, 200, 500, 1K, 2K or 3K devices
Suggested Layout for PCB Design	PL-400
Evaluation Board	TB-805+
Environmental Ratings	ENV08T1

ESD RATING

Human Body Model (HBM): Class 1A (250 to <500V) in accordance with ANSI/ESD STM 5.1 - 2001

Machine Model (MM): Class M1 (pass 25V) in accordance with ANSI/ESD STM5.2-1999

MSL RATING

Moisture Sensitivity: MSL1 in accordance with IPC/JEDEC J-STD-020D

MSL TEST FLOW CHART

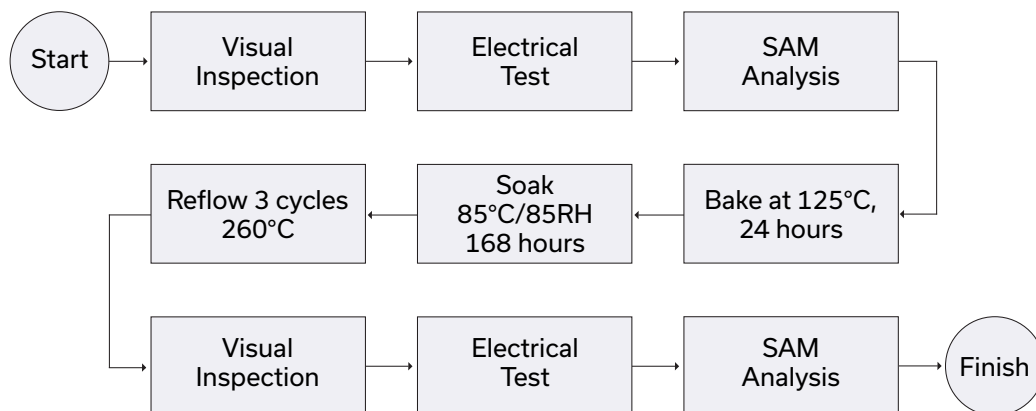

NOTES

- A. Performance and quality attributes and conditions not expressly stated in this specification document are intended to be excluded and do not form a part of this specification document.
- B. Electrical specifications and performance data contained in this specification document are based on Mini-Circuit's applicable established test performance criteria and measurement instructions.
- C. The parts covered by this specification document are subject to Mini-Circuits standard limited warranty and terms and conditions (collectively, "Standard Terms"); Purchasers of this part are entitled to the rights and benefits contained therein. For a full statement of the standard. Terms and the exclusive rights and remedies thereunder, please visit Mini-Circuits' website at www.minicircuits.com/MCLStore/terms.jsp



Looking for pricing, stock, or lifecycle information?

Click below to explore more details on WIN SOURCE:

 [View PMA2-43LN+ on WIN SOURCE](#)

 [Mini-Circuits Information](#)

Optimize Your Supply Chain with WIN SOURCE Solutions

-  Global Sourcing Solution
-  Obsolete Management
-  Cost Control Management
-  Shortage Management
-  Alternative Solution
-  Excess Inventory Management