



**THE DATASHEET OF
SI5319C-C-GM**



ANY-FREQUENCY PRECISION CLOCK MULTIPLIER/JITTER ATTENUATOR

Features

- Generates any frequency from 2 kHz to 945 MHz and select frequencies to 1.4 GHz from an input frequency of 2 kHz to 710 MHz
- Ultra-low jitter clock output with jitter generation as low as 0.3 ps rms (50 kHz–80 MHz)
- Integrated loop filter with selectable loop bandwidth (60 Hz to 8.4 kHz)
- Meets OC-192 GR-253-CORE jitter specifications
- Clock or crystal input with manual clock selection
- Selectable clock output signal format (LVPECL, LVDS, CML, CMOS)
- Support for ITU G.709 and custom OTN FEC ratios (e.g. 255/238, 255/237, 255/236)
- Supports various frequency translations for Synchronous Ethernet
- LOL, LOS alarm outputs
- I²C or SPI programmable
- On-chip voltage regulator for 1.8 V ±5%, 2.5 V ±10% or 3.3 V ±10% operation
- Small size: 6 x 6 mm 36-lead QFN
- Pb-free, ROHS compliant

Applications

- 10G/40G/100G OTN line cards
- SONET/SDH OC-48/STM-16 and OC-192/STM-64 line cards
- GbE/10GbE, 1/2/4/8/10GFC line cards
- ITU G.709 and custom FEC line cards
- Synchronous Ethernet
- Optical modules
- Wireless basestations
- Data converter clocking
- DSLAM/MSANs
- Test and measurement
- Broadcast video
- Discrete PLL replacement

Description

The Si5319 is a jitter-attenuating precision M/N clock multiplier for applications requiring sub 1 ps jitter performance. The Si5319 accepts one clock input ranging from 2 kHz to 710 MHz and generates one clock output ranging from 2 kHz to 945 MHz and select frequencies to 1.4 GHz. The Si5319 can also use its crystal oscillator as a clock source for free-running clock generation. The device provides virtually any frequency translation combination across this operating range. The Si5319 input clock frequency and clock multiplication ratio are programmable through an I²C or SPI interface. The Si5319 is based on Silicon Laboratories' third-generation DSPLL[®] technology, which provides any-frequency synthesis and jitter attenuation in a highly integrated PLL solution that eliminates the need for external VCXO and loop filter components. The DSPLL loop bandwidth is digitally programmable, providing jitter performance optimization at the application level. Operating from a single 1.8, 2.5, or 3.3 V supply, the Si5319 is ideal for providing clock multiplication and jitter attenuation in high performance timing applications.

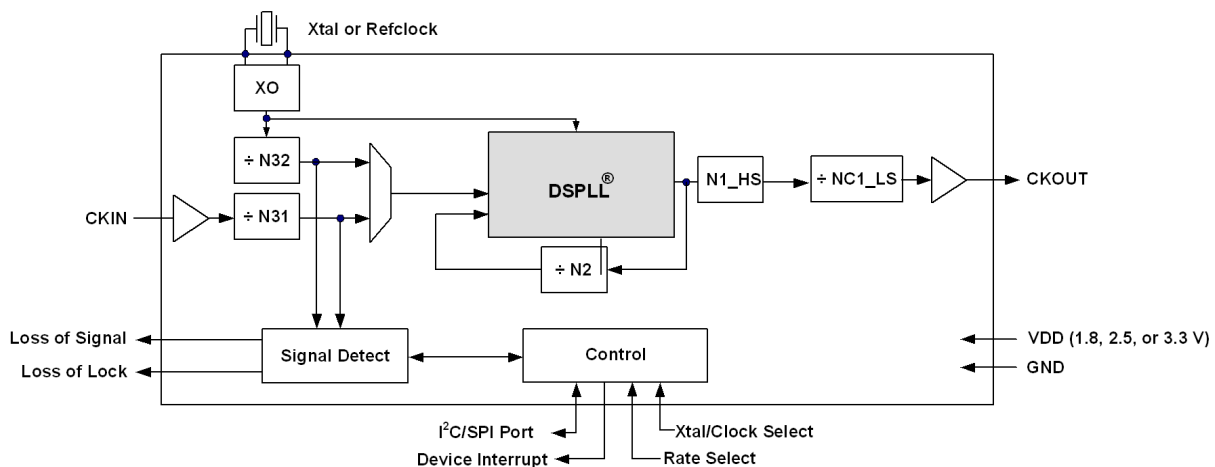

TABLE OF CONTENTS

<u>Section</u>	<u>Page</u>
1. Electrical Specifications	4
2. Typical Phase Noise Plots	14
2.1. Example: SONET OC-192	14
3. Functional Description	16
3.1. External Reference	16
3.2. Further Documentation	16
4. Register Map	17
5. Pin Descriptions: Si5319	40
6. Ordering Guide	43
7. Package Outline: 36-Pin QFN	44
8. Recommended PCB Layout	45
9. Si5319 Device Top Mark	47
Document Change List	48
Contact Information	50

1. Electrical Specifications

Table 1. Recommended Operating Conditions

Parameter	Symbol	Test Condition	Min	Typ	Max	Unit
Ambient Temperature	T_A		-40	25	85	°C
Supply Voltage during Normal Operation	V_{DD}	3.3 V Nominal	2.97	3.3	3.63	V
		2.5 V Nominal	2.25	2.5	2.75	V
		1.8 V Nominal	1.71	1.8	1.89	V

Note: All minimum and maximum specifications are guaranteed and apply across the recommended operating conditions. Typical values apply at nominal supply voltages and an operating temperature of 25 °C unless otherwise stated.

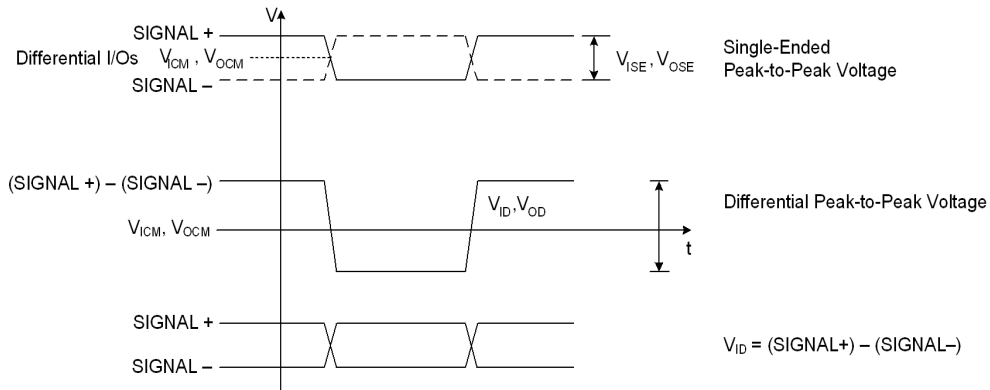

Figure 1. Differential Voltage Characteristics

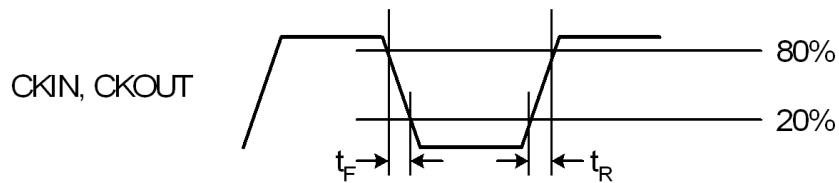

Figure 2. Rise/Fall Time Characteristics

Table 2. DC Characteristics $(V_{DD} = 1.8 \pm 5\%, 2.5 \pm 10\%, \text{ or } 3.3 \text{ V} \pm 10\%, T_A = -40 \text{ to } 85 \text{ }^\circ\text{C})$

Parameter	Symbol	Test Condition	Min	Typ	Max	Unit
Supply Current ¹	I_{DD}	LVPECL Format 622.08 MHz Out	—	217	243	mA
		CMOS Format 19.44 MHz Out	—	194	220	mA
		Disable Mode	—	165	—	mA
CKIN Input Pin²						
Input Common Mode Voltage (Input Threshold Voltage)	V_{ICM}	1.8 V \pm 5%	0.9	—	1.4	V
		2.5 V \pm 10%	1	—	1.7	V
		3.3 V \pm 10%	1.1	—	1.95	V
Input Resistance	CKN_{RIN}	Single-ended	20	40	60	k Ω
Single-Ended Input Voltage Swing (See Absolute Specs)	V_{ISE}	$f_{CKIN} < 212.5$ MHz See Figure 1.	0.2	—	—	V_{PP}
		$f_{CKIN} > 212.5$ MHz See Figure 1.	0.25	—	—	V_{PP}
Differential Input Voltage Swing (See Absolute Specs)	V_{ID}	$f_{CKIN} < 212.5$ MHz See Figure 1.	0.2	—	—	V_{PP}
		$f_{CKIN} > 212.5$ MHz See Figure 1.	0.25	—	—	V_{PP}
Output Clock (CKOUT)³						
Common Mode	CKO_{VCM}	LVPECL 100 Ω load line-to-line	$V_{DD} - 1.42$	—	$V_{DD} - 1.25$	V
Differential Output Swing	CKO_{VD}	LVPECL 100 Ω load line-to-line	1.1	—	1.9	V_{PP}
Single Ended Output Swing	CKO_{VSE}	LVPECL 100 Ω load line-to-line	0.5	—	0.93	V_{PP}
Differential Output Voltage	CKO_{VD}	CML 100 Ω load line-to-line	350	425	500	m V_{PP}
Notes:						
1. Current draw is independent of supply voltage.						
2. No under- or overshoot is allowed.						
3. LVPECL outputs require nominal $V_{DD} \geq 2.5$ V.						
4. This is the amount of leakage that the 3-level inputs can tolerate from an external driver. See Si53xx Family Reference Manual for more details.						
5. LVPECL, CML, LVDS and low-swing LVDS measured with $F_o = 622.08$ MHz.						

Table 2. DC Characteristics (Continued)

($V_{DD} = 1.8 \pm 5\%$, $2.5 \pm 10\%$, or $3.3 \text{ V} \pm 10\%$, $T_A = -40$ to $85 \text{ }^\circ\text{C}$)

Parameter	Symbol	Test Condition	Min	Typ	Max	Unit
Common Mode Output Voltage	CKO_{VCM}	CML 100 Ω load line-to-line	—	$V_{DD} - 0.36$	—	V
Differential Output Voltage	CKO_{VD}	LVDS 100 Ω load line-to-line	500	700	900	mV _{PP}
		Low Swing LVDS 100 Ω load line-to-line	350	425	500	mV _{PP}
Common Mode Output Voltage	CKO_{VCM}	LVDS 100 Ω load line-to-line	1.125	1.2	1.275	V
Differential Output Resistance	CKO_{RD}	CML, LVPECL, LVDS	—	200	—	Ω
Output Voltage Low	CKO_{VOLLH}	CMOS	—	—	0.4	V
Output Voltage High	CKO_{VOHLH}	$V_{DD} = 1.71 \text{ V}$ CMOS	$0.8 \times V_{DD}$	—	—	V
Output Drive Current (CMOS driving into CKO_{VOL} for output low or CKO_{VOH} for output high. $CKOUT+$ and $CKOUT-$ shorted externally)	CKO_{IO}	ICMOS[1:0] =11 $V_{DD} = 1.8 \text{ V}$	—	7.5	—	mA
		ICMOS[1:0] =10 $V_{DD} = 1.8 \text{ V}$	—	5.5	—	mA
		ICMOS[1:0] =01 $V_{DD} = 1.8 \text{ V}$	—	3.5	—	mA
		ICMOS[1:0] =00 $V_{DD} = 1.8 \text{ V}$	—	1.75	—	mA
		ICMOS[1:0] =11 $V_{DD} = 3.3 \text{ V}$	—	32	—	mA
		ICMOS[1:0] =10 $V_{DD} = 3.3 \text{ V}$	—	24	—	mA
		ICMOS[1:0] =01 $V_{DD} = 3.3 \text{ V}$	—	16	—	mA
		ICMOS[1:0] =00 $V_{DD} = 3.3 \text{ V}$	—	8	—	mA

Notes:

1. Current draw is independent of supply voltage.
2. No under- or overshoot is allowed.
3. LVPECL outputs require nominal $V_{DD} \geq 2.5 \text{ V}$.
4. This is the amount of leakage that the 3-level inputs can tolerate from an external driver. See Si53xx Family Reference Manual for more details.
5. LVPECL, CML, LVDS and low-swing LVDS measured with $F_o = 622.08 \text{ MHz}$.

Table 2. DC Characteristics (Continued) $(V_{DD} = 1.8 \pm 5\%, 2.5 \pm 10\%, \text{ or } 3.3 \text{ V} \pm 10\%, T_A = -40 \text{ to } 85 \text{ }^\circ\text{C})$

Parameter	Symbol	Test Condition	Min	Typ	Max	Unit
2-Level LVCMOS Input Pins						
Input Voltage Low	V_{IL}	$V_{DD} = 1.71 \text{ V}$	—	—	0.5	V
		$V_{DD} = 2.25 \text{ V}$	—	—	0.7	V
		$V_{DD} = 2.97 \text{ V}$	—	—	0.8	V
Input Voltage High	V_{IH}	$V_{DD} = 1.89 \text{ V}$	1.4	—	—	V
		$V_{DD} = 2.25 \text{ V}$	1.8	—	—	V
		$V_{DD} = 3.63 \text{ V}$	2.5	—	—	V
3-Level Input Pins⁴						
Input Voltage Low	V_{ILL}		—	—	$0.15 \times V_{DD}$	V
Input Voltage Mid	V_{IMM}		$0.45 \times V_{DD}$	—	$0.55 \times V_{DD}$	V
Input Voltage High	V_{IHH}		$0.85 \times V_{DD}$	—	—	V
Input Low Current	I_{ILL}	See Note 4	-20	—	—	μA
Input Mid Current	I_{IMM}	See Note 4	-2	—	+2	μA
Input High Current	I_{IHH}	See Note 4	—	—	20	μA
LVCMOS Output Pins						
Output Voltage Low	V_{OL}	$I_O = 2 \text{ mA}$ $V_{DD} = 1.71 \text{ V}$	—	—	0.4	V
Output Voltage Low		$I_O = 2 \text{ mA}$ $V_{DD} = 2.97 \text{ V}$	—	—	0.4	V
Notes:						
1. Current draw is independent of supply voltage.						
2. No under- or overshoot is allowed.						
3. LVPECL outputs require nominal $V_{DD} \geq 2.5 \text{ V}$.						
4. This is the amount of leakage that the 3-level inputs can tolerate from an external driver. See Si53xx Family Reference Manual for more details.						
5. LVPECL, CML, LVDS and low-swing LVDS measured with $F_o = 622.08 \text{ MHz}$.						

Table 2. DC Characteristics (Continued)

($V_{DD} = 1.8 \pm 5\%$, $2.5 \pm 10\%$, or $3.3 \text{ V} \pm 10\%$, $T_A = -40$ to $85 \text{ }^\circ\text{C}$)

Parameter	Symbol	Test Condition	Min	Typ	Max	Unit
Output Voltage High	V_{OH}	$I_O = -2 \text{ mA}$ $V_{DD} = 1.71 \text{ V}$	$V_{DD} - 0.4$	—	—	V
Output Voltage High		$I_O = -2 \text{ mA}$ $V_{DD} = 2.97 \text{ V}$	$V_{DD} - 0.4$	—	—	V
Disabled Leakage Current	I_{OZ}	$RSTb = 0$	-100	—	100	μA

Notes:

1. Current draw is independent of supply voltage.
2. No under- or overshoot is allowed.
3. LVPECL outputs require nominal $V_{DD} \geq 2.5 \text{ V}$.
4. This is the amount of leakage that the 3-level inputs can tolerate from an external driver. See Si53xx Family Reference Manual for more details.
5. LVPECL, CML, LVDS and low-swing LVDS measured with $F_o = 622.08 \text{ MHz}$.

Table 3. Microprocessor Control

($V_{DD} = 1.8 \pm 5\%$, $2.5 \pm 10\%$, or $3.3 \text{ V} \pm 10\%$, $T_A = -40$ to $85 \text{ }^\circ\text{C}$)

Parameter	Symbol	Test Condition	Min	Typ	Max	Unit
I²C Bus Lines (SDA, SCL)						
Input Voltage Low	$V_{IL_{I2C}}$		—	—	$0.25 \times V_{DD}$	V
Input Voltage High	$V_{IH_{I2C}}$		$0.7 \times V_{DD}$	—	V_{DD}	V
Input Current	I_{I2C}	$V_{IN} = 0.1 \times V_{DD}$ to $0.9 \times V_{DD}$	-10	—	10	μA
Hysteresis of Schmitt trigger inputs	$V_{HYS_{I2C}}$	$V_{DD} = 1.8\text{V}$	$0.1 \times V_{DD}$	—	—	V
		$V_{DD} = 2.5$ or 3.3 V	$0.05 \times V_{DD}$	—	—	V
Output Voltage Low	$V_{OL_{I2C}}$	$V_{DD} = 1.8 \text{ V}$ $I_O = 3 \text{ mA}$	—	—	$0.2 \times V_{DD}$	V
		$V_{DD} = 2.5$ or 3.3 V $I_O = 3 \text{ mA}$	—	—	0.4	V
SPI Specifications						
Duty Cycle, SCLK	t_{DC}	SCLK = 10 MHz	40	—	60	%
Cycle Time, SCLK	t_c		100	—	—	ns
Rise Time, SCLK	t_r	20–80%	—	—	25	ns
Fall Time, SCLK	t_f	20–80%	—	—	25	ns

Table 3. Microprocessor Control (Continued) $(V_{DD} = 1.8 \pm 5\%, 2.5 \pm 10\%, \text{ or } 3.3 \text{ V} \pm 10\%, T_A = -40 \text{ to } 85 \text{ }^\circ\text{C})$

Parameter	Symbol	Test Condition	Min	Typ	Max	Unit
Low Time, SCLK	t_{lsc}	20–20%	30	—	—	ns
High Time, SCLK	t_{hsc}	80–80%	30	—	—	ns
Delay Time, SCLK Fall to SDO Active	t_{d1}		—	—	25	ns
Delay Time, SCLK Fall to SDO Transition	t_{d2}		—	—	25	ns
Delay Time, SS Rise to SDO Tri-state	t_{d3}		—	—	25	ns
Setup Time, SS to SCLK Fall	t_{su1}		25	—	—	ns
Hold Time, SS to SCLK Rise	t_{h1}		20	—	—	ns
Setup Time, SDI to SCLK Rise	t_{su2}		25	—	—	ns
Hold Time, SDI to SCLK Rise	t_{h2}		20	—	—	ns
Delay Time between Slave Selects	t_{cs}		25	—	—	ns

Table 4. AC Specifications $(V_{DD} = 1.8 \pm 5\%, 2.5 \pm 10\%, \text{ or } 3.3 \text{ V} \pm 10\%, T_A = -40 \text{ to } 85 \text{ }^\circ\text{C})$

Parameter	Symbol	Test Condition	Min	Typ	Max	Unit
Single-Ended Reference Clock Input Pin XA (XB with cap to GND)						
Input Resistance	XA_{RIN}	RATE[1:0] = LM or MH, ac coupled	—	12	—	k Ω
Input Voltage Swing	XA_{VPP}	RATE[1:0] = LM or MH, ac coupled	0.5	—	1.2	V_{PP}
Differential Reference Clock Input Pins (XA/XB)						
Input Voltage Swing	XA/XB_{VPP}	RATE[1:0] = LM or MH	0.5	—	1.2	V_{PP} , each.
CKIN Input Pins						
Input Frequency	CKN_F		0.002	—	710	MHz

Table 4. AC Specifications (Continued)

($V_{DD} = 1.8 \pm 5\%$, $2.5 \pm 10\%$, or $3.3 V \pm 10\%$, $T_A = -40$ to $85\text{ }^\circ\text{C}$)

Parameter	Symbol	Test Condition	Min	Typ	Max	Unit
Input Duty Cycle (Minimum Pulse Width)	CKN _{DC}	Whichever is smaller (i.e., the 40% / 60% limitation applies only to high-frequency clocks)	40	—	60	%
			2	—	—	ns
Input Capacitance	CKN _{CIN}		—	—	3	pF
Input Rise/Fall Time	CKN _{TRF}	20–80% See Figure 2	—	—	11	ns
CKOUT Output Pins						
(See ordering section for speed grade vs frequency limits)						
Output Frequency (Output not configured for CMOS or Disabled)	CKO _F	N1 ≥ 6	0.002	—	945	MHz
		N1 = 5	970	—	1134	MHz
		N1 = 4	1.213	—	1.4	GHz
Maximum Output Frequency in CMOS Format	CKO _F		—	—	212.5	MHz
Output Rise/Fall (20–80 %) @ 622.08 MHz output	CKO _{TRF}	Output not configured for CMOS or Disabled See Figure 2	—	230	350	ps
Output Rise/Fall (20–80%) @ 212.5 MHz output	CKO _{TRF}	CMOS Output $V_{DD} = 1.71$ $C_{LOAD} = 5\text{ pF}$	—	—	8	ns
Output Rise/Fall (20–80%) @ 212.5 MHz output	CKO _{TRF}	CMOS Output $V_{DD} = 2.97$ $C_{LOAD} = 5\text{ pF}$	—	—	2	ns
Output Duty Cycle Uncertainty @ 622.08 MHz	CKO _{DC}	100 Ω Load Line-to-Line Measured at 50% Point (Not for CMOS)	—	—	+/-40	ps
LVC MOS Input Pins						
Minimum Reset Pulse Width	t _{RSTMN}		1	—	—	μs
Reset to Microprocessor Access Ready	t _{READY}		—	—	10	ms
Input Capacitance	C _{in}		—	—	3	pF

Table 4. AC Specifications (Continued)(V_{DD} = 1.8 ± 5%, 2.5 ± 10%, or 3.3 V ± 10%, T_A = -40 to 85 °C)

Parameter	Symbol	Test Condition	Min	Typ	Max	Unit
LVC MOS Output Pins						
Rise/Fall Times	t _{RF}	C _{LOAD} = 20pf See Figure 2	—	25	—	ns
LOS _n Trigger Window	LOS _{TRIG}	From last CKIN _n ↑ to ↓ Internal detection of LOS _n N3 ≠ 1	—	—	4.5 x N3	T _{CKIN}
Time to Clear LOL after LOS Cleared	t _{CLRLOL}	↓LOS to ↓LOL Fold = F _{new} Stable Xa/XB reference	—	10	—	ms
Device Skew						
Input to Output Phase Change Due to Tem- perature Variation	t _{TEMP}	Max phase changes from -40 to +85 °C	—	300	500	ps
PLL Performance (f _{in} =f _{out} = 622.08 MHz; BW=120 Hz; LVPECL)						
Lock Time	t _{LOCKMP}	Start of ICAL to ↓ of LOL	—	35	1200	ms
Output Clock Phase Change	t _{P_STEP}	After clock switch f ₃ ≥ 128 kHz	—	200	—	ps
Closed Loop Jitter Peaking	J _{PK}		—	0.05	0.1	dB
Jitter Tolerance	J _{TOL}	Jitter Frequency ≥ Loop Bandwidth	5000/BW	—	—	ns pk-pk
Phase Noise f _{out} = 622.08 MHz	CKO _{PN}	1 kHz Offset	—	-106	-87	dBc/Hz
		10 kHz Offset	—	-121	-100	dBc/Hz
		100 kHz Offset	—	-132	-104	dBc/Hz
		1 MHz Offset	—	-132	-119	dBc/Hz
Subharmonic Noise	SP _{SUBH}	Phase Noise @ 100 kHz Offset	—	-88	-76	dBc
Spurious Noise	SP _{SPUR}	Max spur @ n x F3 (n ≥ 1, n x F3 < 100 MHz)	—	-93	-70	dBc

Table 5. Jitter Generation

Parameter	Symbol	Test Condition*		Min	Typ	Max	GR-253-Specification	Unit
		Measurement Filter	DSPLL BW ²					
Jitter Gen OC-192	J _{GEN}	0.02–80 MHz	120 Hz	—	4.2	6.2	30	ps _{pp}
				—	0.27	0.42	N/A	ps _{rms}
		4–80 MHz	120 Hz	—	3.7	6.4	10	ps _{pp}
				—	0.14	0.31	N/A	ps _{rms}
		0.05–80 MHz	120 Hz	—	4.4	6.9	10	ps _{pp}
				—	0.26	0.41	1.0	ps _{rms}
Jitter Gen OC-48	J _{GEN}	0.12–20 MHz	120 Hz	—	3.5	5.4	40.2	ps _{pp}
				—	0.27	0.41	4.02	ps _{rms}

***Note:** Test conditions:
 1. f_{IN} = f_{OUT} = 622.08 MHz
 2. Clock input: LVPECL
 3. Clock output: LVPECL
 4. PLL bandwidth: 120 Hz
 5. 114.285 MHz 3rd OT crystal used as XA/XB input
 6. V_{DD} = 2.5 V
 7. T_A = 85 °C

Table 6. Thermal Characteristics

(V_{DD} = 1.8 ±5%, 2.5 ±10%, or 3.3 V ±10%, T_A = –40 to 85 °C)

Parameter	Symbol	Test Condition	Value	Unit
Thermal Resistance Junction to Ambient	θ _{JA}	Still Air	32	C°/W
Thermal Resistance Junction to Case	θ _{JC}	Still Air	14	C°/W

Table 7. Absolute Maximum Limits

Parameter	Symbol	Test Condition	Min	Typ	Max	Unit
DC Supply Voltage	V_{DD}		-0.5	—	3.8	V
LVC MOS Input Voltage	V_{DIG}		-0.3		$V_{DD}+0.3$	V
CKINn Voltage Level Limits	CKN_{VIN}		0	—	V_{DD}	V
XA/XB Voltage Level Limits	XA_{VIN}		0	—	1.2	V
Operating Junction Temperature	T_{JCT}		-55	—	150	°C
Storage Temperature Range	T_{STG}		-55	—	150	°C
ESD HBM Tolerance (100 pF, 1.5 k Ω); All pins except CKIN+/CKIN-			2	—	—	kV
ESD MM Tolerance; All pins except CKIN+/CKIN-			150	—	—	V
ESD HBM Tolerance (100 pF, 1.5 k Ω); CKIN+/CKIN-			750	—	—	V
ESD MM Tolerance; CKIN+/CKIN-			100	—	—	V
Latch-up Tolerance			JESD78 Compliant			
Note: Permanent device damage may occur if the Absolute Maximum Ratings are exceeded. Functional operation should be restricted to the conditions as specified in the operation sections of this data sheet. Exposure to absolute maximum rating conditions for extended periods of time may affect device reliability.						

2. Typical Phase Noise Plots

The following typical phase noise plot was taken using a Rohde and Schwarz SML03 RF Generator as the clock input source to the Si5326. The Agilent model E5052B was used for the phase noise measurement. For this measurement, the Si5319 operates at 3.3 V with an ac coupled differential PECL output and an ac coupled differential sine wave input from the RF generator at 0 dBm. Note that, as with any PLL, the output jitter that is below the loop BW is caused by the jitter at the input clock. The loop BW was 120 Hz.

2.1. Example: SONET OC-192

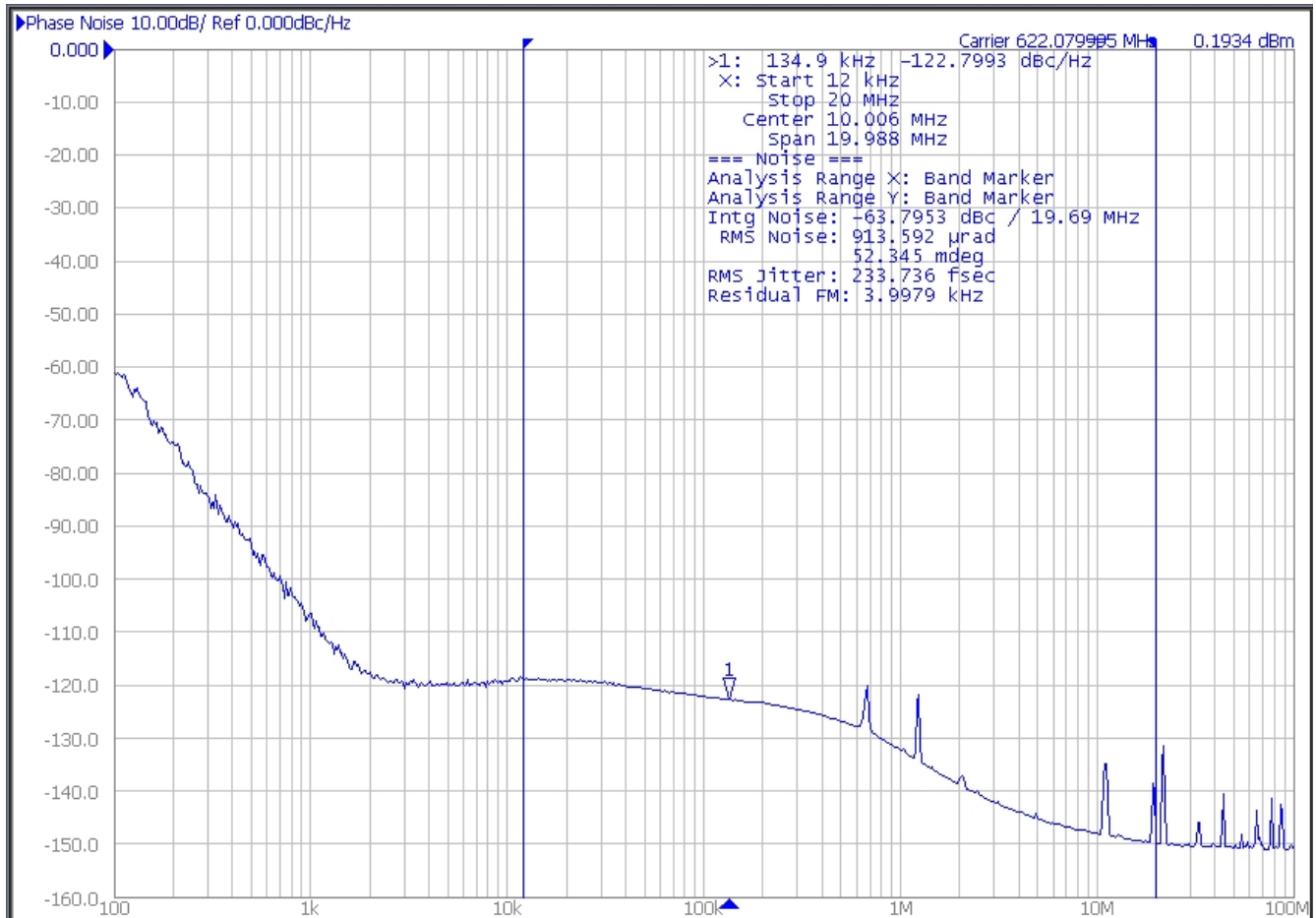

Figure 3. Typical Phase Noise Plot

T

Jitter Band	Jitter, RMS
SONET_OC48, 12 kHz to 20 MHz	250 fs
SONET_OC192_A, 20 kHz to 80 MHz	274 fs
SONET_OC192_B, 4 to 80 MHz	166 fs
SONET_OC192_C, 50 kHz to 80 MHz	267 fs
Brick Wall, 800 Hz to 80 MHz	274 fs

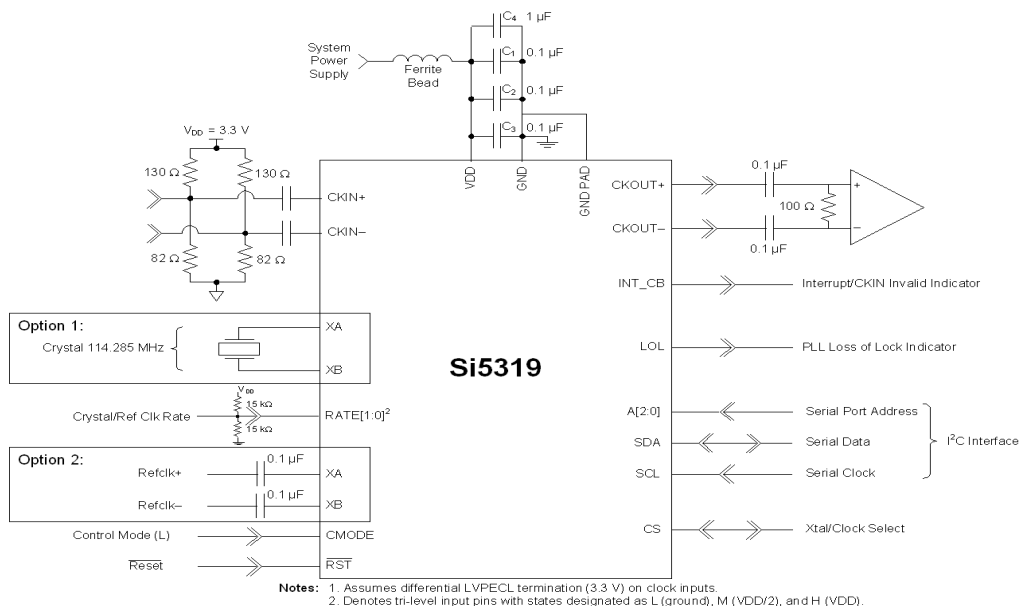

Figure 4. Si5319 Typical Application Circuit (I²C Control Mode)

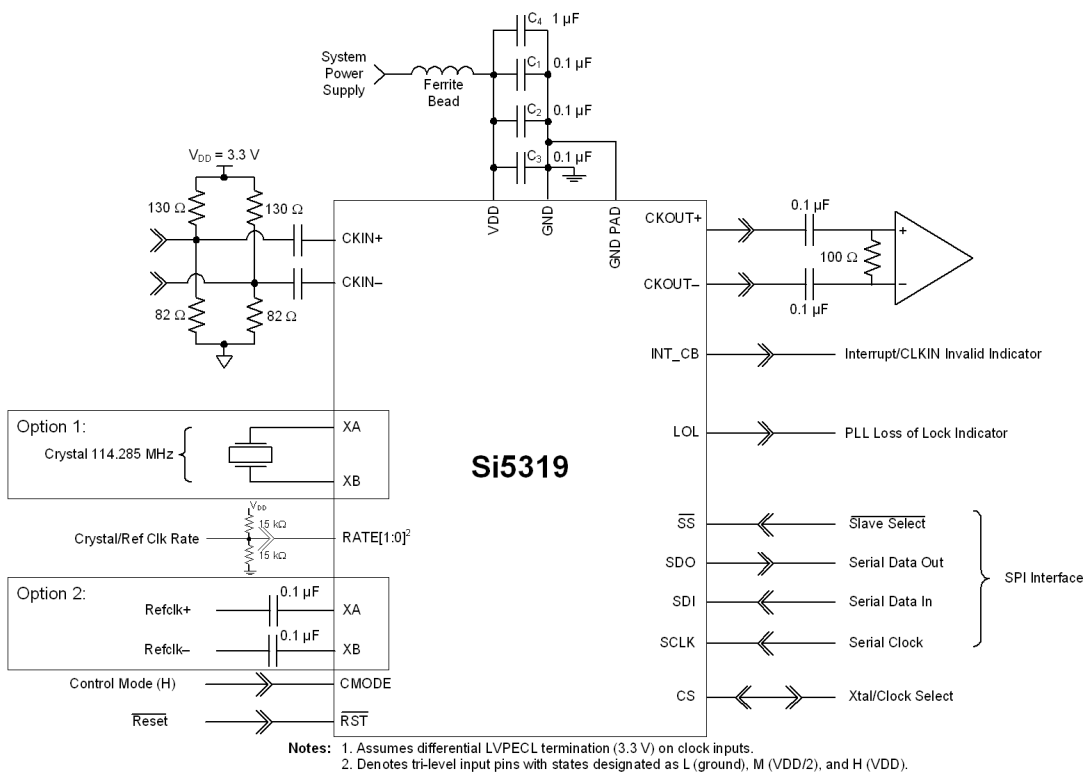

Figure 5. Si5319 Typical Application Circuit (SPI Control Mode)

3. Functional Description

The Si5319 is a jitter-attenuating precision clock multiplier for applications requiring sub 1 ps jitter performance. The Si5319 accepts one clock input ranging from 2 kHz to 710 MHz and generates one clock output ranging from 2 kHz to 945 MHz and select frequencies to 1.4 GHz. The Si5319 can also use its crystal oscillator as a clock source for frequency synthesis. The device provides virtually any frequency translation combination across this operating range. The Si5319 input clock frequency and clock multiplication ratio are programmable through an I²C or SPI interface. Silicon Laboratories offers a PC-based software utility, *DSPLLsim*, that can be used to determine the optimum PLL divider settings for a given input frequency/clock multiplication ratio combination that minimizes phase noise and power consumption. This utility can be downloaded from <http://www.silabs.com/timing>.

The Si5319 is based on Silicon Laboratories' third generation DSPLL[®] technology, which provides any-frequency synthesis and jitter attenuation in a highly integrated PLL solution that eliminates the need for external VCXO and loop filter components. The Si5319 PLL loop bandwidth is digitally programmable and supports a range from 60 Hz to 8.4 kHz. The *DSPLLsim* software utility can be used to calculate valid loop bandwidth settings for a given input clock frequency/clock multiplication ratio.

The Si5319 monitors the input clock for loss-of-signal and provides a LOS alarm when it detects missing pulses on the input clock. The device monitors the lock status of the PLL. The lock detect algorithm works by continuously monitoring the phase of the input clock in relation to the phase of the feedback clock.

The Si5319 provides a VCO freeze capability that allows the device to continue generation of a stable output clock when the selected input reference is lost. During VCO freeze, the DSPLL latches its VCO settings and uses its XO as its frequency reference.

The Si5319 has one differential clock output. The electrical format of the clock output is programmable to support LVPECL, LVDS, CML, or CMOS loads. For system-level debugging, a bypass mode is available which drives the output clock directly from the input clock, bypassing the internal DSPLL. The device is powered by a single 1.8, 2.5, or 3.3 V supply.

3.1. External Reference

A low-cost 114.285 MHz 3rd overtone crystal or an external reference oscillator is used as part of a fixed-frequency oscillator within the DSPLL. This external reference is required for the device to operate. Silicon Laboratories recommends using a high quality crystal. Specific recommendations may be found in the Family Reference Manual. An external oscillator as well as other crystal frequencies can also be used as a reference for the device.

In VCO Freeze, the DSPLL remains locked to this external reference. Any changes in the frequency of this reference when the DSPLL is in VCO freeze will be tracked by the output of the device. Note that crystals can have temperature sensitivities.

3.2. Further Documentation

Consult the Silicon Laboratories Any-Frequency Precision Clock Family Reference Manual (FRM) for detailed information about the Si5319. Additional design support is available from Silicon Laboratories through your distributor.

Silicon Laboratories has developed a PC-based software utility called *DSPLLsim* to simplify device configuration, including frequency planning and loop bandwidth selection. The FRM and this utility can be downloaded from <http://www.silabs.com/timing>.

4. Register Map

All register bits that are not defined in this map should always be written with the specified Reset Values. The writing to these bits of values other than the specified Reset Values may result in undefined device behavior. Do not write to registers not listed in the register map, such as Register 64.

Register	D7	D6	D5	D4	D3	D2	D1	D0
0		FREE_RUN	CKOUT_ ALWAYS_ ON				BYPASS_ REG	
2	BWSEL_REG[3:0]							
3			VCO_ FREEZE	SQ_ICAL				
5	ICMOS[1:0]							
6						SFOUT1_REG[2:0]		
8			HLOG[1:0]					
10						DSBL_REG		
11								PD_CK
19			VALTIME[1:0]			LOCK[T2:0]		
20							LOL_PIN	INT_PIN
22							LOL_POL	INT_POL
23							LOS_MSK	LOSX_MSK
24								LOL_MSK
25	N1_HS[2:0]							
31					NC1_LS[19:16]			
32	NC1_LS[15:8]							
33	NC1_LS[7:0]							
40	N2_HS[2:0]				N2_LS[19:16]			
41	N2_LS[15:8]							
42	N2_LS[7:0]							
43						N31[18:16]		
44	N31[15:8]							
45	N31[7:0]							
46						N32[18:16]		
47	N32[15:8]							
48	N32[7:0]							

Si5319

Register	D7	D6	D5	D4	D3	D2	D1	D0
128								CK_ACT-V_REG
129							LOS_INT	LOSX_INT
130								LOL_INT
131							LOS_FLG	LOSX_FLG
132							LOL_FLG	
134	PARTNUM_RO[11:4]							
135	PARTNUM_RO[3:0]				REVID_RO[3:0]			
136	RST_REG	ICAL					GRADE_RO[1:0]	
138								LOS_EN [1:1]
139				LOS_EN [0:0]				
185	NVM_REVID[7:0]							

Register 0.

Bit	D7	D6	D5	D4	D3	D2	D1	D0
Name		FREE_ RUN	CKOUT_ ALWAYS_ ON				BYPASS_ REG	
Type	R	R/W	R/W	R	R	R	R/W	R

Reset value = 0001 0100

Bit	Name	Function
7	Reserved	Reserved.
6	FREE_RUN	Free Run. Internal to the device, route XA/XB to CKIN2. This allows the device to lock to its XA-XB reference (either internal or external). 0: Disable 1: Enable
5	CKOUT_ ALWAYS_ON	CKOUT Always On. This will bypass the SQ_ICAL function. Output will be available even if SQ_ICAL is on and ICAL is not complete or successful. See Table 9 on page 39. 0: Squelch output until part is calibrated (ICAL). 1: Device generates output clock, including during calibration. Note: The frequency may be significantly off until the part is calibrated.
4:2	Reserved	Reserved.
1	BYPASS_ REG	Bypass Register. This bit enables or disables the PLL bypass mode. Use only when the device is in VCO_-FREEZE or before the first ICAL. Bypass mode is not supported for CMOS output clocks. 0: Normal operation 1: Bypass mode. Selected input clock is connected to CKOUT buffers, bypassing PLL.
0	Reserved	Reserved.

Register 2.

Bit	D7	D6	D5	D4	D3	D2	D1	D0
Name	BWSEL_REG [3:0]				Reserved			
Type	R/W				R			

Reset value = 0100 0010

Bit	Name	Function
7:4	BWSEL_REG [3:0]	BWSEL_REG. Selects nominal f3dB bandwidth for PLL. See the <i>DSPLLsim</i> for settings. After BWSEL_REG is written with a new value, an ICAL is required for the change to take effect.
3:0	Reserved	Reserved.

Register 3.

Bit	D7	D6	D5	D4	D3	D2	D1	D0
Name	Reserved		VCO_FREEZE	SQ_ICAL	Reserved			
Type	R		R/W	R/W	R			

Reset value = 0000 0101

Bit	Name	Function
7:6	Reserved	Reserved.
5	VCO_FREEZE	VCO_FREEZE. Forces the part into VCO Freeze. This bit overrides all other manual and automatic clock selection controls. 0: Normal operation. 1: Force VCO Freeze mode. Overrides all other settings and ignores the quality of all of the input clocks.
4	SQ_ICAL	SQ_ICAL. This bit determines if the output clocks will remain enabled or be squelched (disabled) during an internal calibration. See Table 9 on page 39. 0: Output clocks enabled during ICAL. 1: Output clocks disabled during ICAL.
3:0	Reserved	Reserved.

Register 5.

Bit	D7	D6	D5	D4	D3	D2	D1	D0
Name	ICMOS [1:0]		Reserved					
Type	R/W		R					

Reset value = 1110 1101

Bit	Name	Function
7:6	ICMOS [1:0]	ICMOS [1:0]. When the output buffer is set to CMOS mode, these bits determine the output buffer drive strength. The first number below refers to 3.3 V operation; the second to 1.8 V operation. These values assume CKOUT+ is tied to CKOUT-. 00: 8 mA/2 mA. 01: 16 mA/4 mA 10: 24 mA/6 mA 11: 32 mA/ 8mA
5:0	Reserved	Reserved.

Register 6.

Bit	D7	D6	D5	D4	D3	D2	D1	D0
Name	Reserved		Reserved			SFOUT_REG [2:0]		
Type	R		R			R/W		

Reset value = 0010 1101

Bit	Name	Function
7:3	Reserved	Reserved.
2:0	SFOUT_ REG [2:0]	SFOUT_REG [2:0]. Controls output signal format and disable for CKOUT output buffer. Bypass mode is not supported for CMOS output clocks. 000: Reserved 001: Disable 010: CMOS 011: Low swing LVDS 100: Reserved 101: LVPECL 110: CML 111: LVDS

Si5319

Register 8.

Bit	D7	D6	D5	D4	D3	D2	D1	D0
Name	Reserved		HLOG[1:0]		Reserved			
Type	R		R/W		R			

Reset value = 0000 0000

Bit	Name	Function
7:6	Reserved	Reserved.
5:4		HLOG [1:0]. 00: Normal operation. 01: Holds CKOUT output at static logic 0. Entrance and exit from this state will occur without glitches or runt pulses. 10: Holds CKOUT output at static logic 1. Entrance and exit from this state will occur without glitches or runt pulses. 11: Reserved.
3:0	Reserved	Reserved.

Register 10.

Bit	D7	D6	D5	D4	D3	D2	D1	D0
Name	Reserved					DSBL_ REG	Reserved	
Type	R					R/W	R	

Reset value = 0000 0000

Bit	Name	Function
7:3	Reserved	Reserved.
2	DSBL_REG	DSBL_REG. This bit controls the powerdown of the CKOUT output buffer. If disable mode is selected, the NC_LS output divider is also powered down. 0: CKOUT enabled. 1: CKOUT disabled.
1:0	Reserved	Reserved.

Register 11.

Bit	D7	D6	D5	D4	D3	D2	D1	D0
Name	Reserved							PD_CK
Type	R							R/W

Reset value = 0100 0000

Bit	Name	Function
7:1	Reserved	Reserved.
0	PD_CK	PD_CK. This bit controls the powerdown of the CKIN input buffer. 0: CKIN enabled. 1: CKIN disabled.

Register 19.

Bit	D7	D6	D5	D4	D3	D2	D1	D0
Name	Reserved			VALTIME [1:0]		LOCKT [2:0]		
Type	R			R/W		R/W		

Reset value = 0010 1100

Bit	Name	Function
7:5	FOS_EN	Reserved.
4:3	VALTIME [1:0]	VALTIME [1:0]. Sets amount of time for input clock to be valid before the associated alarm is removed. 00: 2 ms 01: 100 ms 10: 200 ms 11: 13 seconds
2:0	LOCKT [2:0]	LOCKT [2:0]. Sets retrigger interval for one shot monitoring phase detector output. One shot is triggered by a phase slip in the DSPLL. Refer to the Family Reference Manual for more details. 000: 106 ms 001: 53 ms 010: 26.5 ms 011: 13.3 ms 100: 6.6 ms 101: 3.3 ms 110: 1.66 ms 111: .83 ms

Register 20.

Bit	D7	D6	D5	D4	D3	D2	D1	D0
Name	Reserved						LOL_PIN	INT_PIN
Type	R						R/W	R/W

Reset value = 0011 1110

Bit	Name	Function
7:2	Reserved	Reserved.
1	LOL_PIN	LOL_PIN. The LOL_INT status bit can be reflected on the LOL output pin. 0: LOL output pin tristated 1: LOL_INT status reflected to output pin
0	INT_PIN	INT_PIN. Reflects the interrupt status on the INT_CB output pin. 0: Interrupt status not displayed on INT_CB output pin. If CK1_BAD_PIN = 0, INT_CB output pin is tristated. 1: Interrupt status reflected to output pin. Instead, the INT_CB pin indicates when CKIN is bad.

Register 22.

Bit	D7	D6	D5	D4	D3	D2	D1	D0
Name	Reserved						LOL_POL	INT_POL
Type	R						R/W	R/W

Reset value = 1101 1111

Bit	Name	Function
7:2	Reserved	Reserved.
2	CK_BAD_POL	CK_BAD_POL. Sets the active polarity for the INT_CB and C2B signals when reflected on output pins. 0: Active low 1: Active high
1	LOL_POL	LOL_POL. Sets the active polarity for the LOL status when reflected on an output pin. 0: Active low 1: Active high
0	INT_POL	INT_POL. Sets the active polarity for the interrupt status when reflected on the INT_CB output pin. 0: Active low 1: Active high

Register 23.

Bit	D7	D6	D5	D4	D3	D2	D1	D0
Name	Reserved						LOS_MSK	LOSX_MSK
Type	R						R/W	R/W

Reset value = 0001 1111

Bit	Name	Function
7:2	Reserved	Reserved.
1	LOS_MSK	LOS_MSK. Determines if a LOS on CKIN (LOS_FLG) is used in the generation of an interrupt. Writes to this register do not change the value held in the LOS_FLG register. 0: LOS alarm triggers active interrupt on INT_CB output (if INT_PIN=1). 1: LOS_FLG ignored in generating interrupt output.
0	LOSX_MSK	LOSX_MSK. Determines if a LOS on XA/XB(LOSX_FLG) is used in the generation of an interrupt. Writes to this register do not change the value held in the LOSX_FLG register. 0: LOSX alarm triggers active interrupt on INT_CB output (if INT_PIN=1). 1: LOSX_FLG ignored in generating interrupt output.

Register 24.

Bit	D7	D6	D5	D4	D3	D2	D1	D0
Name	Reserved							LOL_MSK
Type	R							R/W

Reset value = 0011 1111

Bit	Name	Function
7:2	Reserved	Reserved.
0	LOL_MSK	LOL_MSK. Determines if the LOL_FLG is used in the generation of an interrupt. Writes to this register do not change the value held in the LOL_FLG register. 0: LOL alarm triggers active interrupt on INT_CB output (if INT_PIN=1). 1: LOL_FLG ignored in generating interrupt output.

Si5319

Register 25.

Bit	D7	D6	D5	D4	D3	D2	D1	D0
Name	N1_HS [2:0]				Reserved			
Type	R/W				R			

Reset value = 0010 0000

Bit	Name	Function
7:5	N1_HS [2:0]	N1_HS [2:0]. Sets value for N1 high speed divider which drives NC1_LS low-speed divider. 000: N1= 4 001: N1= 5 010: N1=6 011: N1= 7 100: N1= 8 101: N1= 9 110: N1= 10 111: N1= 11
4:0	Reserved	Reserved.

Register 31.

Bit	D7	D6	D5	D4	D3	D2	D1	D0
Name	Reserved				NC1_LS [19:16]			
Type	R				R/W			

Reset value = 0000 0000

Bit	Name	Function
7:4	Reserved	Reserved.
3:0	NC1_LS [19:16]	NC1_LS [19:16]. Sets value for NC1_LS divider, which drives CKOUT output. The value of the register must be either odd or zero. 00000000000000000000 = 1 00000000000000000001 = 2 00000000000000000011 = 4 00000000000000000101 = 6 ... 11111111111111111111=2^20 Valid divider values=[1, 2, 4, 6, ..., 2^20]

Register 32.

Bit	D7	D6	D5	D4	D3	D2	D1	D0
Name	NC1_LS [15:8]							
Type	R/W							

Reset value = 0000 0000

Bit	Name	Function
7:0	NC1_LS [15:8]	<p>NC1_LS [15:8]. Sets value for NC1_LS, which drives CKOUT output. The value of the register must be either odd or zero.</p> <p>00000000000000000000 = 1 00000000000000000001 = 2 00000000000000000011 = 4 00000000000000000101 = 6 ... 11111111111111111111=2^20 Valid divider values=[1, 2, 4, 6, ..., 2^20]</p>

Register 33.

Bit	D7	D6	D5	D4	D3	D2	D1	D0
Name	NC1_LS [7:0]							
Type	R/W							

Reset value = 0011 0001

Bit	Name	Function
7:0	NC1_LS [19:0]	<p>NC1_LS [7:0]. Sets value for NC1_LS, which drives CKOUT output. The value of the register must be either odd or zero.</p> <p>00000000000000000000 = 1 00000000000000000001 = 2 00000000000000000011 = 4 00000000000000000101 = 6 ... 11111111111111111111=2^20 Valid divider values=[1, 2, 4, 6, ..., 2^20]</p>

Register 40.

Bit	D7	D6	D5	D4	D3	D2	D1	D0
Name	N2_HS [2:0]			Reserved	N2_LS [19:16]			
Type	R/W			R	R/W			

Reset value = 1100 0000

Bit	Name	Function
7:5	N2_HS [2:0]	N2_HS [2:0]. Sets value for N2 high speed divider which drives N2_LS low-speed divider. 000: 4 001: 5 010: 6 011: 7 100: 8 101: 9 110: 10 111: 11
4	Reserved	Reserved.
3:0	N2_LS [19:16]	N2_LS [19:16]. Sets value for N2 low-speed divider, which drives phase detector. 00000000000000000001 = 2 00000000000000000011 = 4 00000000000000000101 = 6 ... 11111111111111111111 = 2 ²⁰ Valid divider values = [2, 4, 6, ..., 2 ²⁰]

Register 41.

Bit	D7	D6	D5	D4	D3	D2	D1	D0
Name	N2_LS [15:8]							
Type	R/W							

Reset value = 0000 0000

Bit	Name	Function
7:0	N2_LS [15:8]	N2_LS [15:8]. Sets value for N2 low-speed divider, which drives phase detector. 00000000000000000001 = 2 00000000000000000011 = 4 00000000000000000101 = 6 ... 11111111111111111111 = 2 ²⁰ Valid divider values = [2, 4, 6, ..., 2 ²⁰]

Register 42.

Bit	D7	D6	D5	D4	D3	D2	D1	D0
Name	N2_LS [7:0]							
Type	R/W							

Reset value = 1111 1001

Bit	Name	Function
7:0	N2_LS [7:0]	N2_LS [7:0]. Sets value for N2 low-speed divider, which drives phase detector. 00000000000000000001 = 2 00000000000000000011 = 4 00000000000000000101 = 6 ... 11111111111111111111 = 2 ²⁰ Valid divider values = [2, 4, 6, ..., 2 ²⁰]

Si5319

Register 43.

Bit	D7	D6	D5	D4	D3	D2	D1	D0
Name	Reserved					N31 [18:16]		
Type	R					R/W		

Reset value = 0000 0000

Bit	Name	Function
7:3	Reserved	Reserved.
2:0	N31 [18:16]	N31 [18:16]. Sets value for input divider for CKIN. 00000000000000000000 = 1 00000000000000000001 = 2 00000000000000000010 = 3 ... 11111111111111111111 = 2 ¹⁹ Valid divider values=[1, 2, 3, ..., 2 ¹⁹]

Register 44.

Bit	D7	D6	D5	D4	D3	D2	D1	D0
Name	N31_[15:8]							
Type	R/W							

Reset value = 0000 0000

Bit	Name	Function
7:0	N31_[15:8]	N31_[15:8]. Sets value for input divider for CKIN. 00000000000000000000 = 1 00000000000000000001 = 2 00000000000000000010 = 3 ... 11111111111111111111 = 2 ¹⁹ Valid divider values=[1, 2, 3, ..., 2 ¹⁹]

Register 45.

Bit	D7	D6	D5	D4	D3	D2	D1	D0
Name	N31_[7:0]							
Type	R/W							

Reset value = 0000 1001

Bit	Name	Function
7:0	N31_[7:0]	N31_[7:0]. Sets value for input divider for CKIN. 00000000000000000000 = 1 00000000000000000001 = 2 00000000000000000010 = 3 ... 11111111111111111111 = 2 ¹⁹ Valid divider values=[1, 2, 3, ..., 2 ¹⁹]

Register 46.

Bit	D7	D6	D5	D4	D3	D2	D1	D0
Name	Reserved					N32_[18:16]		
Type	R					R/W		

Reset value = 0000 0000

Bit	Name	Function
7:3	Reserved	Reserved.
2:0	N32_[18:16]	N32_[18:16]. Sets value for input divider for the XO clock in free-run mode. 00000000000000000000 = 1 00000000000000000001 = 2 00000000000000000010 = 3 ... 11111111111111111111 = 2 ¹⁹ Valid divider values=[1, 2, 3, ..., 2 ¹⁹]

Si5319

Register 47.

Bit	D7	D6	D5	D4	D3	D2	D1	D0
Name	N32_[15:8]							
Type	R/W							

Reset value = 0000 0000

Bit	Name	Function
7:0	N32_[15:8]	N32_[15:8]. Sets value for input divider for the XO clock in free-run mode. 00000000000000000000 = 1 00000000000000000001 = 2 00000000000000000010 = 3 ... 11111111111111111111 = 2 ¹⁹ Valid divider values=[1, 2, 3, ..., 2 ¹⁹]

Register 48.

Bit	D7	D6	D5	D4	D3	D2	D1	D0
Name	N32_[7:0]							
Type	R/W							

Reset value = 0000 1001

Bit	Name	Function
7:0	N32_[7:0]	N32_[7:0]. Sets value for input divider for the XO clock in free-run mode. 00000000000000000000 = 1 00000000000000000001 = 2 00000000000000000010 = 3 ... 11111111111111111111 = 2 ¹⁹ Valid divider values=[1, 2, 3, ..., 2 ¹⁹]

Register 128.

Bit	D7	D6	D5	D4	D3	D2	D1	D0
Name	Reserved							CK_ACTV_REG
Type	R							R

Reset value = 0010 0000

Bit	Name	Function
7:1	Reserved	Reserved.
0	CK_ACTV_REG	CK_ACTV_REG. Indicates if CKIN is currently the active clock for the PLL input. 0: CKIN is not the active input clock. Either it is not selected or LOS_INT is 1. 1: CKIN is the active input clock.

Register 129.

Bit	D7	D6	D5	D4	D3	D2	D1	D0
Name	Reserved						LOS_INT	LOSX_INT
Type	R						R	R

Reset value = 0000 0110

Bit	Name	Function
7:2	Reserved	Reserved.
1	LOS_INT	LOS_INT. Indicates the LOS status on CKIN. 0: Normal operation. 1: Internal loss-of-signal alarm on CKIN input.
0	LOSX_INT	LOSX_INT. Indicates the LOS status of the external reference on the XA/XB pins. 0: Normal operation. 1: Internal loss-of-signal alarm on XA/XB reference clock input.

Si5319

Register 130.

Bit	D7	D6	D5	D4	D3	D2	D1	D0
Name	Reserved							LOL_INT
Type	R							R

Reset value = 0000 0001

Bit	Name	Function
7:3	Reserved	Reserved.
0	LOL_INT	PLL Loss of Lock Status. 0: PLL locked. 1: PLL unlocked.

Register 131.

Bit	D7	D6	D5	D4	D3	D2	D1	D0
Name	Reserved						LOS_FLG	LOSX_FLG
Type	R						R/W	R/W

Reset value = 0001 1111

Bit	Name	Function
7:2	Reserved	Reserved.
1	LOS_FLG	CKIN Loss-of-Signal Flag. 0: Normal operation 1: Held version of LOS_INT. Generates active output interrupt if output interrupt pin is enabled (INT_PIN = 1) and if not masked by LOS_MSK bit. Flag cleared by writing 0 to this bit.
0	LOSX_FLG	External Reference (signal on pins XA/XB) Loss-of-Signal Flag. 0: Normal operation 1: Held version of LOSX_INT. Generates active output interrupt if output interrupt pin is enabled (INT_PIN = 1) and if not masked by LOSX_MSK bit. Flag cleared by writing 0 to this bit.

Register 132.

Bit	D7	D6	D5	D4	D3	D2	D1	D0
Name	Reserved						LOL_FLG	Reserved
Type	R						R/W	R

Reset value = 0000 0010

Bit	Name	Function
7:2, 0	Reserved	Reserved.
1	LOL_FLG	PLL Loss of Lock Flag. 0: PLL locked 1: Held version of LOL_INT. Generates active output interrupt if output interrupt pin is enabled (INT_PIN = 1) and if not masked by LOL_MSK bit. Flag cleared by writing 0 to this bit.

Register 134.

Bit	D7	D6	D5	D4	D3	D2	D1	D0
Name	PARTNUM_RO [11:4]							
Type	R							

Reset value = 0000 0001

Bit	Name	Function
7:0	PARTNUM_RO [11:0]	Device ID (1 of 2). 0000 0001 + 0011: Si5319

Si5319

Register 135.

Bit	D7	D6	D5	D4	D3	D2	D1	D0
Name	PARTNUM_RO [3:0]				REVID_RO [3:0]			
Type	R				R			

Reset value = 1010 0010

Bit	Name	Function
7:4	PARTNUM_RO [11:0]	Device ID (2 of 2). 0000 0001 + 0011: Si5319
3:0	REVID_RO [3:0]	Indicates Revision Number of Device. 0000: Revision A 0001: Revision B 0010: Revision C Others: Reserved

Register 136.

Bit	D7	D6	D5	D4	D3	D2	D1	D0
Name	RST_REG	ICAL	Reserved				GRADE_RO [1:0]	
Type	R/W	R/W	R				R	

Reset value = 0000 0000

Bit	Name	Function
7	RST_REG	<p>Internal Reset (Same as Pin Reset).</p> <p>Note: The I2C (or SPI) port may not be accessed until 10 ms after RST_REG is asserted.</p> <p>0: Normal operation.</p> <p>1: Reset of all internal logic. Outputs disabled or tristated during reset.</p>
6	ICAL	<p>Start an Internal Calibration Sequence.</p> <p>For proper operation, the device must go through an internal calibration sequence. ICAL is a self-clearing bit. Writing a one to this location initiates an ICAL. The calibration is complete once the LOL alarm goes low. A valid stable clock (within 100 ppm) must be present to begin ICAL.</p> <p>Note: Any divider, CLKINn_RATE or BWSEL_REG changes require an ICAL to take effect.</p> <p>0: Normal operation.</p> <p>1: Writing a "1" initiates internal self-calibration. Upon completion of internal self-calibration, LOL will go low.</p>
5:2	Reserved	Reserved.
1:0	GRADE_RO [1:0]	<p>Indicates Maximum Clock Output Frequency of this Device.</p> <p>Limits the range of the N1_HS divider.</p> <p>00: N1_HS x NC1_LS > 4. Maximum clock output frequency = 1.4175 GHz.</p> <p>01: N1_HS x NC1_LS > 6. Maximum clock output frequency = 808 MHz.</p> <p>10: N1_HS x NC1_LS > 14. Maximum clock output frequency = 346 MHz.</p> <p>11: N1_HS x NC1_LS > 20. Maximum clock output frequency = 243 MHz.</p>

Register 138.

Bit	D7	D6	D5	D4	D3	D2	D1	D0
Name	Reserved							LOS_EN [1:1]
Type	R							R/W

Reset value = 0000 1111

Bit	Name	Function
7:3	Reserved	Reserved.
0	LOS_EN [1:0]	<p>Enable CKIN LOS Monitoring on the Specified Input (1 of 2).</p> <p>Note: LOS_EN is split between two registers.</p> <p>00: Disable LOS monitoring.</p> <p>01: Reserved.</p> <p>10: Enable LOSA monitoring.</p> <p>11: Enable LOS monitoring.</p> <p>LOSA is a slower and less sensitive version of LOS. See the Family Reference Manual for details.</p>

Register 139.

Bit	D7	D6	D5	D4	D3	D2	D1	D0
Name	Reserved			LOS_EN [0:0]	Reserved			
Type	R			R/W	R			

Reset value = 1111 1111

Bit	Name	Function
7:5	Reserved	Reserved.
4	LOS_EN [1:0]	<p>Enable CKIN LOS Monitoring on the Specified Input (1 of 2).</p> <p>Note: LOS_EN is split between two registers.</p> <p>00: Disable LOS monitoring.</p> <p>01: Reserved.</p> <p>10: Enable LOSA monitoring.</p> <p>11: Enable LOS monitoring.</p> <p>LOSA is a slower and less sensitive version of LOS. See the family reference manual for details.</p>
3:0	Reserved	Reserved.

Register 185.

Bit	D7	D6	D5	D4	D3	D2	D1	D0
Name	NVM_REVID [7:0]							
Type	R							

Reset value = 0001 0011

Bit	Name	Function
7:0	NVM_REVID [7:0]	NVM_REVID.

Table 8. CKOUT_ALWAYS_ON and SQ_ICAL Truth Table

CKOUT_ALWAYS_ON	SQ_ICAL	Results
0	0	CKOUT OFF until after the first ICAL.
0	1	CKOUT OFF until after the first successful ICAL (i.e., when LOL is low).
1	0	CKOUT always ON, including during an ICAL.
1	1	CKOUT always ON, including during an ICAL. Use these settings to preserve output-to-output skew.

Table 9 lists all of the register locations that should be followed by an ICAL after their contents are changed.

Table 9. Register Locations Requiring ICAL

Addr	Register
0	BYPASS_REG
0	CKOUT_ALWAYS_ON
2	BWSEL_REG
5	ICMOS
10	DSBL_REG
11	PD_CK
19	VALTIME
19	LOCKT
25	N1_HS
31	NC1_LS
40	N2_HS
40	N2_LS
43	N31

5. Pin Descriptions: Si5319

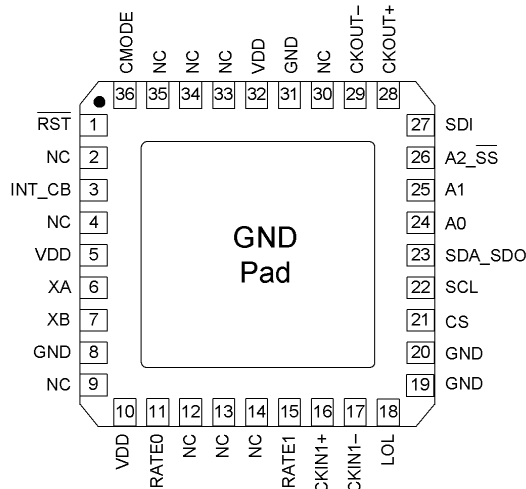

Pin #	Pin Name	I/O	Signal Level	Description						
1	$\overline{\text{RST}}$	I	LVC MOS	<p>External Reset.</p> <p>Active low input that performs external hardware reset of device. Resets all internal logic to a known state and forces the device registers to their default value. Clock outputs are disabled during reset. The part must be programmed after a reset or power-on to get a clock output. See Family Reference Manual for details.</p> <p>This pin has a weak pull-up.</p>						
2, 4, 9, 12–14, 30, 33–35	NC	—	—	<p>No Connection.</p> <p>Leave floating. Make no external connections to this pin for normal operation.</p>						
3	INT_CB	O	LVC MOS	<p>Interrupt/CKIN Invalid Indicator.</p> <p>This pin functions as a device interrupt output or an alarm output for CKIN. If used as an interrupt output, <i>INT_PIN</i> must be set to 1. The pin functions as a maskable interrupt output with active polarity controlled by the <i>INT_POL</i> register bit.</p> <p>If used as an alarm output, the pin functions as a LOS alarm indicator for CKIN. Set <i>CK_BAD_PIN</i> = 1 and <i>INT_PIN</i> = 0.</p> <p>0 = CKIN present. 1 = LOS on CKIN.</p> <p>The active polarity is controlled by <i>CK_BAD_POL</i>. If no function is selected, the pin tristates.</p>						
5, 10, 32	V _{DD}	V _{DD}	Supply	<p>Supply.</p> <p>The device operates from a 1.8, 2.5, or 3.3 V supply. Bypass capacitors should be associated with the following V_{DD} pins:</p> <table> <tr> <td>5</td> <td>0.1 μF</td> </tr> <tr> <td>10</td> <td>0.1 μF</td> </tr> <tr> <td>32</td> <td>0.1 μF</td> </tr> </table> <p>A 1.0 μF should also be placed as close to the device as is practical.</p>	5	0.1 μF	10	0.1 μF	32	0.1 μF
5	0.1 μF									
10	0.1 μF									
32	0.1 μF									
<p>Note: Internal register names are indicated by underlined italics (e.g., <i>INT_PIN</i>. See Si5319 Register Map).</p>										

Pin #	Pin Name	I/O	Signal Level	Description
7 6	XB XA	I	Analog	External Crystal or Reference Clock. External crystal should be connected to these pins to use internal oscillator based reference. Refer to the Family Reference Manual for interfacing to an external reference. The external reference must be from a high-quality clock source (TCXO, OCXO). Frequency of crystal or external clock is set by the RATE pins.
8, 31 19,20	GND	GND	Supply	Ground. Must be connected to system ground. Minimize the ground path impedance for optimal performance of this device. Grounding these pins does not eliminate the requirement to ground the GND PAD on the bottom of the package.
11 15	RATE0 RATE1	I	3-Level	External Crystal or Reference Clock Rate. Three level inputs that select the type and rate of external crystal or reference clock to be applied to the XA/XB port. Refer to the Family Reference Manual for settings. These pins have both a weak pull-up and a weak pull-down; they default to M. The "HH" setting is not supported. Note: L setting corresponds to ground. M setting corresponds to $V_{DD}/2$. H setting corresponds to V_{DD} . Some designs may require an external resistor voltage divider when driven by an active device that will tri-state.
16 17	CKIN+ CKIN-	I	Multi	Clock Input. Differential input clock. This input can also be driven with a single-ended signal. Input frequency range is 2 kHz to 710 MHz.
18	LOL	O	LVC MOS	PLL Loss of Lock Indicator. This pin functions as the active high PLL loss of lock indicator if the <i>LOL_PIN</i> register bit is set to 1. 0 = PLL locked. 1 = PLL unlocked. If <i>LOL_PIN</i> = 0, this pin will tristate. Active polarity is controlled by the <i>LOL_POL</i> bit. The PLL lock status will always be reflected in the <i>LOL_INT</i> read only register bit.
21	CS	I	LVC MOS	Xtal/Input Clock Select. This pin selects the active DSPLL input clock, which can be a clock input or a crystal input. See the <i>FREE_EN</i> register for free run settings. 0 = Select clock input (CKIN). 1 = Select crystal or external reference clock. This pin should not be left open.
22	SCL	I	LVC MOS	Serial Clock/Serial Clock. This pin functions as the serial clock input for both SPI and I ² C modes. This pin has a weak pull-down.
23	SDA_SDO	I/O	LVC MOS	Serial Data. In I ² C control mode (CMODE = 0), this pin functions as the bidirectional serial data port. In SPI control mode (CMODE = 1), this pin functions as the serial data output.

Note: Internal register names are indicated by underlined italics (e.g., *INT_PIN*. See Si5319 Register Map).

Si5319

Pin #	Pin Name	I/O	Signal Level	Description
25 24	A1 A0	I	LVC MOS	Serial Port Address. In I ² C control mode (CMODE = 0), these pins function as hardware controlled address bits. The I ² C address is 1101 [A2] [A1] [A0]. In SPI control mode (CMODE = 1), these pins are ignored. These pins have a weak pull-down.
26	A2 _{SS}	I	LVC MOS	Serial Port Address/Slave Select. In I ² C control mode (CMODE = 0), this pin functions as a hardware controlled address bit [A2]. In SPI control mode (CMODE = 1), this pin functions as the slave select input. This pin has a weak pull-down.
27	SDI	I	LVC MOS	Serial Data In. In I ² C control mode (CMODE = 0), this pin is ignored. In SPI control mode (CMODE = 1), this pin functions as the serial data input. This pin has a weak pull-down.
29 28	CKOUT ₋ CKOUT ₊	O	Multi	Output Clock. Differential output clock with a frequency range of 10 MHz to 1.4175 GHz. Output signal format is selected by <i>SFOUT1_REG</i> register bits. Output is differential for LVPECL, LVDS, and CML compatible modes. For CMOS format, both output pins drive identical single-ended clock outputs.
36	CMODE	I	LVC MOS	Control Mode. Selects I ² C or SPI control mode for the Si5319. 0 = I ² C Control Mode 1 = SPI Control Mode
GND PAD	GND	GND	Supply	Ground Pad. The ground pad must provide a low thermal and electrical impedance to a ground plane.
Note: Internal register names are indicated by underlined italics (e.g., <i>INT_PIN</i>). See Si5319 Register Map).				

6. Ordering Guide

Ordering Part Number	Output Clock Frequency Range	Package	ROHS6, Pb-Free	Temperature Range
Si5319A-C-GM	2 kHz–945 MHz 970–1134 MHz 1.213–1.417 GHz	36-Lead 6 x 6 mm QFN	Yes	–40 to 85 °C
Si5319B-C-GM	2 kHz–808 MHz	36-Lead 6 x 6 mm QFN	Yes	–40 to 85 °C
Si5319C-C-GM	2 kHz–346 MHz	36-Lead 6 x 6 mm QFN	Yes	–40 to 85 °C

Note: Add an R at the end of the device part number to denote tape and reel ordering options.

7. Package Outline: 36-Pin QFN

Figure 6 illustrates the package details for the Si5319. Table 10 lists the values for the dimensions shown in the illustration.

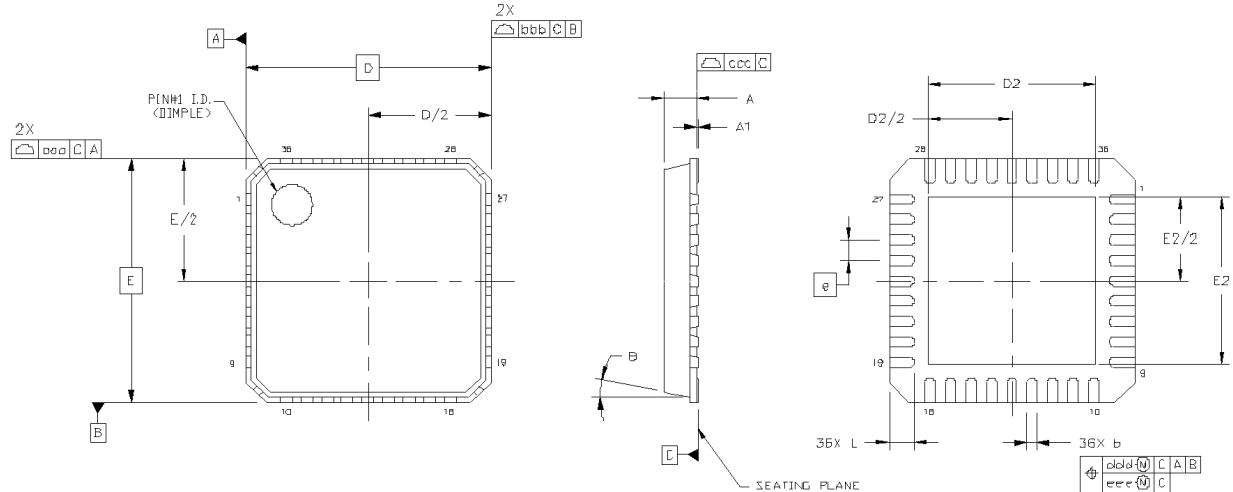

Figure 6. 36-Pin Quad Flat No-lead (QFN)

Table 10. Package Dimensions

Symbol	Millimeters			Symbol	Millimeters		
	Min	Nom	Max		Min	Nom	Max
A	0.80	0.85	0.90	L	0.50	0.60	0.70
A1	0.00	0.02	0.05	θ	—	—	12°
b	0.18	0.25	0.30	aaa	—	—	0.10
D	6.00 BSC			bbb	—	—	0.10
D2	3.95	4.10	4.25	ccc	—	—	0.08
e	0.50 BSC			ddd	—	—	0.10
E	6.00 BSC			eee	—	—	0.05
E2	3.95	4.10	4.25				

Notes:

1. All dimensions shown are in millimeters (mm) unless otherwise noted.
2. Dimensioning and Tolerancing per ANSI Y14.5M-1994.
3. This drawing conforms to JEDEC outline MO-220, variation VJJD.
4. Recommended card reflow profile is per the JEDEC/IPC J-STD-020 specification for Small Body Components.

8. Recommended PCB Layout

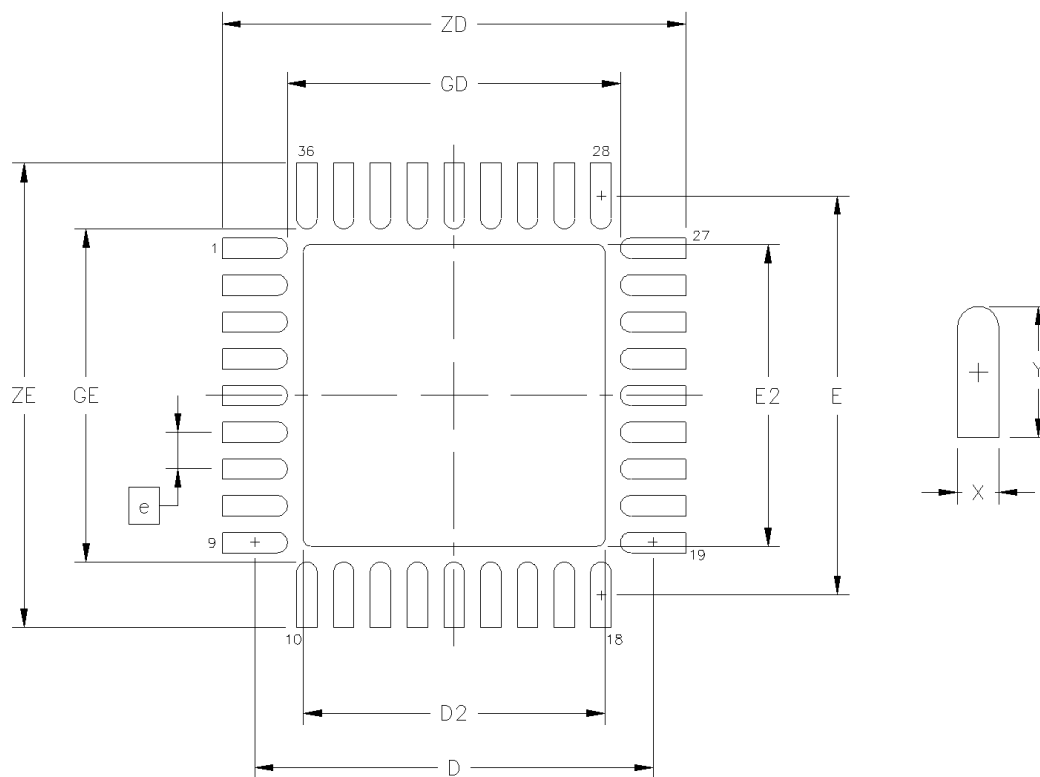

Figure 7. PCB Land Pattern Diagram

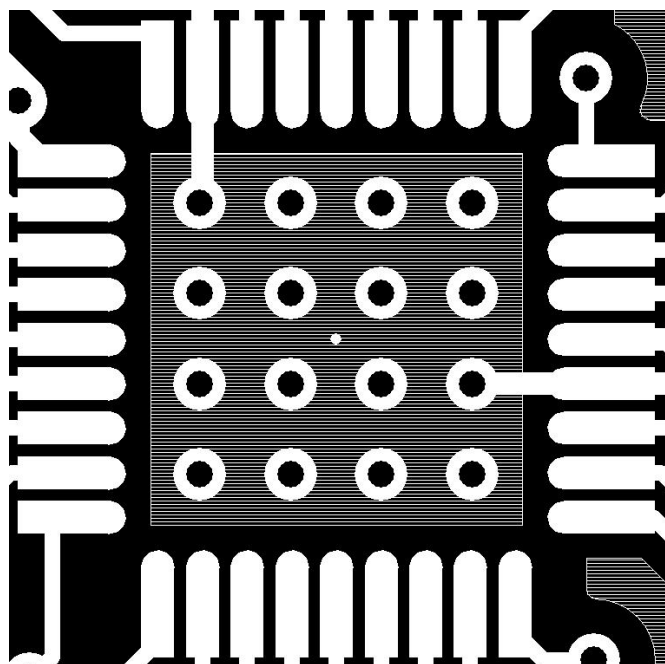

Figure 8. Ground Pad Recommended Layout

Table 11. PCB Land Pattern Dimensions

Dimension	MIN	MAX
e	0.50 BSC.	
E	5.42 REF.	
D	5.42 REF.	
E2	4.00	4.20
D2	4.00	4.20
GE	4.53	—
GD	4.53	—
X	—	0.28
Y	0.89 REF.	
ZE	—	6.31
ZD	—	6.31

Notes (General):

1. All dimensions shown are in millimeters (mm) unless otherwise noted.
2. Dimensioning and Tolerancing is per the ANSI Y14.5M-1994 specification.
3. This Land Pattern Design is based on IPC-SM-782 guidelines.
4. All dimensions shown are at Maximum Material Condition (MMC). Least Material Condition (LMC) is calculated based on a Fabrication Allowance of 0.05 mm.

Notes (Solder Mask Design):

1. All metal pads are to be non-solder mask defined (NSMD). Clearance between the solder mask and the metal pad is to be 60 μm minimum, all the way around the pad.

Notes (Stencil Design):

1. A stainless steel, laser-cut and electro-polished stencil with trapezoidal walls should be used to assure good solder paste release.
2. The stencil thickness should be 0.125 mm (5 mils).
3. The ratio of stencil aperture to land pad size should be 1:1 for the perimeter pads.
4. A 4 x 4 array of 0.80 mm square openings on 1.05 mm pitch should be used for the center ground pad.

Notes (Card Assembly):

1. A No-Clean, Type-3 solder paste is recommended.
2. The recommended card reflow profile is per the JEDEC/IPC J-STD-020 specification for Small Body Components.

9. Si5319 Device Top Mark

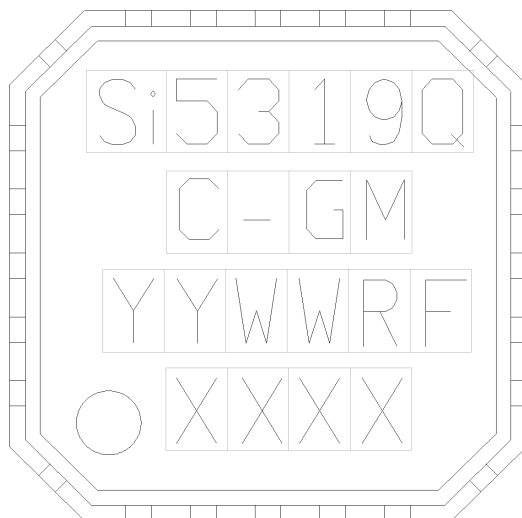

Mark Method:	Laser	
Font Size:	0.80 mm Right-Justified	
Line 1 Marking:	Si5319	Customer Part Number Q = Speed Code: A, B, C See Ordering Guide for options
Line 2 Marking:	C-GM	C = Product Revision G = Temperature Range –40 to 85 °C (RoHS6) M = QFN Package
Line 3 Marking:	YYWWRF	YY = Year WW = Work Week R = Die Revision F = Internal code Assigned by the Assembly House. Corresponds to the year and work week of the mold date.
Line 4 Marking:	Pin 1 Identifier	Circle = 0.75 mm Diameter Lower-Left Justified
	XXXX	Internal Code

DOCUMENT CHANGE LIST

Revision 0.1 to Revision 0.2

- Changed 1.8 V operating range to $\pm 5\%$.
- Updated Table 1 on page 4.
- Updated Table 2 on page 5.
- Added table under Figure 3 on page 14.
- Updated "3. Functional Description" on page 16.
- Clarified "5. Pin Descriptions: Si5319" on page 40.

Revision 0.2 to Revision 0.3

- Updated "5. Pin Descriptions: Si5319" on page 40.
 - Corrected Pins 11 and 15 description in table.

Revision 0.3 to Revision 0.4

- Updated Table 1 on page 4.
- Added "9. Si5319 Device Top Mark" on page 47.

Revision 0.4 to Revision 0.41

- Updated Table 1 on page 4.
 - Updated Thermal Resistance Junction to Ambient typical specification.
- Updated Figure 4, "Si5319 Typical Application Circuit (I²C Control Mode)," on page 15.
- Updated Figure 5, "Si5319 Typical Application Circuit (SPI Control Mode)," on page 15.
- Updated NC pin description in "5. Pin Descriptions: Si5319" on page 40.
- Updated "7. Package Outline: 36-Pin QFN" on page 44.
- Added Figure 8, "Ground Pad Recommended Layout," on page 45.
- Added register map documentation.
- Updated Rise/Fall Time values.

Revision 0.41 to Revision 0.42

- Changed register address labels to decimal.

Revision 0.42 to Revision 0.43

- Updated the following:
 - ESD specifications
 - phase noise values
 - absolute V_{DD} maximum voltage
 - typical phase noise plot
- Added specification for phase changes due to temperature variation
- Added information for the N32 register
- Added θ_{JC} specification

Revision 0.43 to Revision 1.0

- Replaced the specification tables (tables 1 and 2 from rev. 0.43) with the specification tables from the Si53x Reference Manual, rev 0.42.

NOTES:



ClockBuilder Pro

One-click access to Timing tools, documentation, software, source code libraries & more. Available for Windows and iOS (CBGo only).

www.silabs.com/CBPro



Timing Portfolio
www.silabs.com/timing



SW/HW
www.silabs.com/CBPro



Quality
www.silabs.com/quality



Support and Community
community.silabs.com

Disclaimer

Silicon Laboratories intends to provide customers with the latest, accurate, and in-depth documentation of all peripherals and modules available for system and software implementers using or intending to use the Silicon Laboratories products. Characterization data, available modules and peripherals, memory sizes and memory addresses refer to each specific device, and "Typical" parameters provided can and do vary in different applications. Application examples described herein are for illustrative purposes only. Silicon Laboratories reserves the right to make changes without further notice and limitation to product information, specifications, and descriptions herein, and does not give warranties as to the accuracy or completeness of the included information. Silicon Laboratories shall have no liability for the consequences of use of the information supplied herein. This document does not imply or express copyright licenses granted hereunder to design or fabricate any integrated circuits. The products must not be used within any Life Support System without the specific written consent of Silicon Laboratories. A "Life Support System" is any product or system intended to support or sustain life and/or health, which, if it fails, can be reasonably expected to result in significant personal injury or death. Silicon Laboratories products are generally not intended for military applications. Silicon Laboratories products shall under no circumstances be used in weapons of mass destruction including (but not limited to) nuclear, biological or chemical weapons, or missiles capable of delivering such weapons.

Trademark Information

Silicon Laboratories Inc., Silicon Laboratories, Silicon Labs, SiLabs and the Silicon Labs logo, CMEMS®, EFM, EFM32, EFR, Energy Micro, Energy Micro logo and combinations thereof, "the world's most energy friendly microcontrollers", Ember®, EZLink®, EZMac®, EZRadio®, EZRadioPRO®, DSPLL®, ISOmodem®, Precision32®, ProSLIC®, SiPHY®, USBXpress® and others are trademarks or registered trademarks of Silicon Laboratories Inc. ARM, CORTEX, Cortex-M3 and THUMB are trademarks or registered trademarks of ARM Holdings. Keil is a registered trademark of ARM Limited. All other products or brand names mentioned herein are trademarks of their respective holders.



Silicon Laboratories Inc.
400 West Cesar Chavez
Austin, TX 78701
USA

<http://www.silabs.com>

Looking for pricing, stock, or lifecycle information?

Click below to explore more details on WIN SOURCE:

 [View SI5319C-C-GM on WIN SOURCE](#)

 [Silicon Labs](#) Information

Optimize Your Supply Chain with WIN SOURCE Solutions

-  Global Sourcing Solution
-  Obsolete Management
-  Cost Control Management
-  Shortage Management
-  Alternative Solution
-  Excess Inventory Management