



**THE DATASHEET OF
LC75878W-E**



LC75878W

1/8 to 1/10-Duty General-Purpose LCD Driver



ON Semiconductor®

www.onsemi.com

Overview

The LC75878W is 1/8 to 1/10 duty general-purpose LCD display driver used for character and graphics display. This product operates under the control of a microcontroller and can directly drive an LCD with up to 730 segments. It can also control up to 4 general-purpose output ports.

Features

- 1/8duty-1/4bias, 1/9duty-1/4bias, and 1/10duty-1/4bias drive schemes can be controlled from serial data.
 - 1/8duty-1/4bias: up to 600 segments
 - 1/9duty-1/4bias: up to 666 segments
 - 1/10duty-1/4bias: up to 730 segments
- Serial data input supports CCB* format communication with the system controller.
- Serial data control of the power-saving mode based backup function and all the segments forced off function.
- Direct display of display data without the use of a decoder provides high generality.
- Built-in display contrast adjustment circuit.
- Up to 4 general-purpose output ports are included.
- Independent LCD driver block power supply V_{LCD} .
- The INH pin is provided. This pin turns off the display and forces the general-purpose output ports to the low level.
- RC oscillator circuit

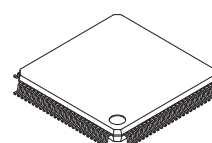

SPQFP100 14x14 / SQFP100

* Computer Control Bus (CCB) is an ON Semiconductor's original bus format and the bus addresses are controlled by ON Semiconductor.

ORDERING INFORMATION

See detailed ordering and shipping information on page 36 of this data sheet.

LC75878W

Specifications

Absolute Maximum Ratings at Ta = 25°C, VSS = 0 V

Parameter	Symbol	Conditions	Ratings	Unit
Maximum supply voltage	VDD max	VDD	-0.3 to +7.0	V
	VLCD max	VLCD	-0.3 to +12.0	
Input voltage	VIN1	CE, CL, DI, $\overline{\text{INH}}$	-0.3 to +7.0	V
	VIN2	OSC	-0.3 to VDD+0.3	
	VIN3	VLCD1, VLCD2, VLCD3, VLCD4	-0.3 to VLCD+0.3	
Output voltage	VOU1	OSC, P1 to P4	-0.3 to VDD+0.3	V
	VOU2	VLCD0, S1 to S75, COM1 to COM10	-0.3 to VLCD+0.3	
Output current	IOU1	S1 to S75	300	μA
	IOU2	COM1 to COM10	3	mA
	IOU3	P1 to P4	5	
Allowable power dissipation	Pd max	Ta = 85°C	200	mW
Operating temperature	Topr		-40 to +85	°C
Storage temperature	Tstg		-55 to +125	°C

Stresses exceeding those listed in the Maximum Ratings table may damage the device. If any of these limits are exceeded, device functionality should not be assumed, damage may occur and reliability may be affected.

Allowable Operating Ranges at Ta = -40 to +85°C, VSS = 0 V

Parameter	Symbol	Conditions	Ratings			unit
			min	typ	max	
Supply voltage	VDD	VDD	2.7		6.0	V
	VLCD	VLCD. When the display contrast adjustment circuit is used	7.0		11.0	
	VLCD	VLCD. When the display contrast adjustment circuit is not used	4.5		11.0	
Output voltage	VLCD0	VLCD0	VLCD4 +4.5		VLCD	V
Input voltage	VLCD1	VLCD1		$\frac{3}{4}(\text{VLCD0} - \text{VLCD4})$	VLCD0	V
	VLCD2	VLCD2		$\frac{2}{4}(\text{VLCD0} - \text{VLCD4})$	VLCD0	
	VLCD3	VLCD3		$\frac{1}{4}(\text{VLCD0} - \text{VLCD4})$	VLCD0	
	VLCD4	VLCD4	0		1.5	
Input high level voltage	VIH	CE, CL, DI, $\overline{\text{INH}}$	$0.8V_{\text{DD}}$		6.0	V
Input low level voltage	VIL	CE, CL, DI, $\overline{\text{INH}}$	0		$0.2V_{\text{DD}}$	V
Recommended external resistance	ROSC	OSC		43		k Ω
Recommended external capacitance	COsc	OSC		680		pF
Guaranteed oscillation range	fOSC	OSC	25	50	100	kHz
Data setup time	tds	CL, DI [Figure 2]	160			ns
Data hold time	tdh	CL, DI [Figure 2]	160			ns
CE wait time	tcp	CE, CL [Figure 2]	160			ns
CE setup time	tcs	CE, CL [Figure 2]	160			ns
CE hold time	tch	CE, CL [Figure 2]	160			ns
High level clock pulse width	t ϕ H	CL [Figure 2]	160			ns
Low level clock pulse width	t ϕ L	CL [Figure 2]	160			ns
$\overline{\text{INH}}$ switching time	tc	$\overline{\text{INH}}$, CE [Figure 3], [Figure 4], [Figure 5]	10			μs

Functional operation above the stresses listed in the Recommended Operating Ranges is not implied. Extended exposure to stresses beyond the Recommended Operating Ranges limits may affect device reliability.

LC75878W

Electrical Characteristics for the Allowable Operating Ranges

Parameter	Symbol	Conditions	Ratings			unit
			min	typ	max	
Hysteresis	V _H	CE, CL, DI, $\overline{\text{INH}}$		0.1V _{DD}		V
Input high level current	I _{IH}	CE, CL, DI, $\overline{\text{INH}}$: V _I = 6.0 V			5.0	μA
Input low level current	I _{IL}	CE, CL, DI, $\overline{\text{INH}}$: V _I = 0 V	-5.0			μA
Output high level voltage	V _{OH1}	S1 to S75: I _O = -20 μA	V _{LCD0} -0.6			V
	V _{OH2}	COM1 to COM10: I _O = -100 μA	V _{LCD0} -0.6			
	V _{OH3}	P1 to P4: I _O = -1 mA	V _{DD} -1.0			
Output low level voltage	V _{OL1}	S1 to S75: I _O = 20 μA			V _{LCD4} +0.6	V
	V _{OL2}	COM1 to COM10: I _O = 100 μA			V _{LCD4} +0.6	
	V _{OL3}	P1 to P4: I _O = 1 mA			1.0	
Output middle level voltage *1	V _{MID1}	S1 to S75: I _O = ±20 μA	2/4(V _{LCD0} -V _{LCD4}) -0.6		2/4(V _{LCD0} -V _{LCD4}) +0.6	V
	V _{MID2}	COM1 to COM10: I _O = ±100 μA	3/4(V _{LCD0} -V _{LCD4}) -0.6		3/4(V _{LCD0} -V _{LCD4}) +0.6	
	V _{MID3}	COM1 to COM10: I _O = ±100 μA	1/4(V _{LCD0} -V _{LCD4}) -0.6		1/4(V _{LCD0} -V _{LCD4}) +0.6	
Oscillator frequency	f _{OSC}	OSC: R _{OSC} = 43 kΩ, C _{OSC} = 680 pF	40	50	60	kHz
Current drain	I _{DD1}	V _{DD} : Power saving mode			5	μA
	I _{DD2}	V _{DD} : V _{DD} = 6.0 V, Outputs open f _{OSC} = 50 kHz		200	400	
	I _{LCD1}	V _{LCD} : Power saving mode			5	
	I _{LCD2}	V _{LCD} : V _{LCD} = 11.0 V Outputs open f _{OSC} = 50 kHz When the display contrast adjustment circuit is used.		500	1000	
	I _{LCD3}	V _{LCD} : V _{LCD} = 11.0 V Outputs open f _{OSC} = 50 kHz When the display contrast adjustment circuit is not used.		250	500	

Note: *1. Excluding the bias voltage generation divider resistor built into V_{LCD0}, V_{LCD1}, V_{LCD2}, V_{LCD3}, and V_{LCD4}. (See Figure 1.)

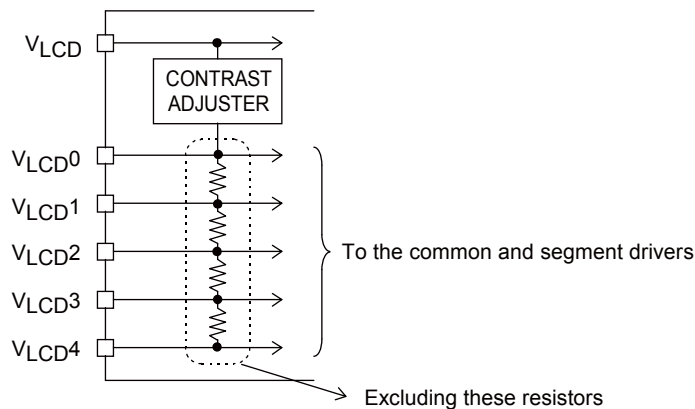
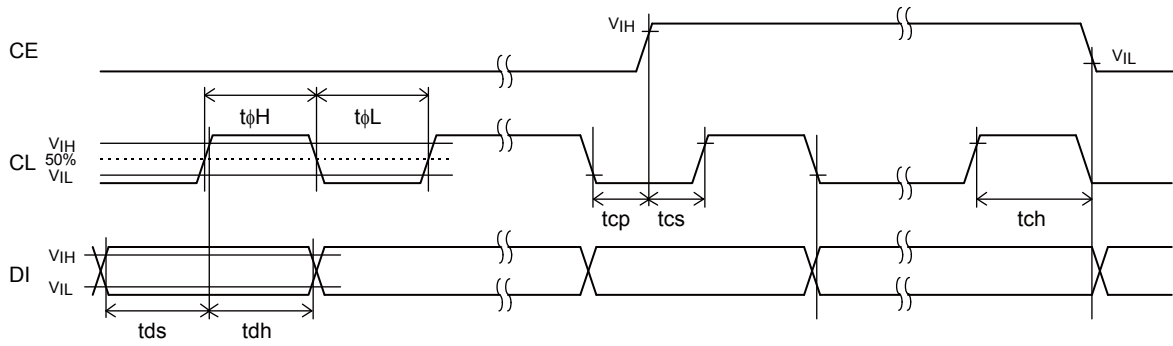

Figure 1

Product parametric performance is indicated in the Electrical Characteristics for the listed test conditions, unless otherwise noted. Product performance may not be indicated by the Electrical Characteristics if operated under different conditions.

LC75878W

1. When CL is stopped at the low level



2. When CL is stopped at the high level

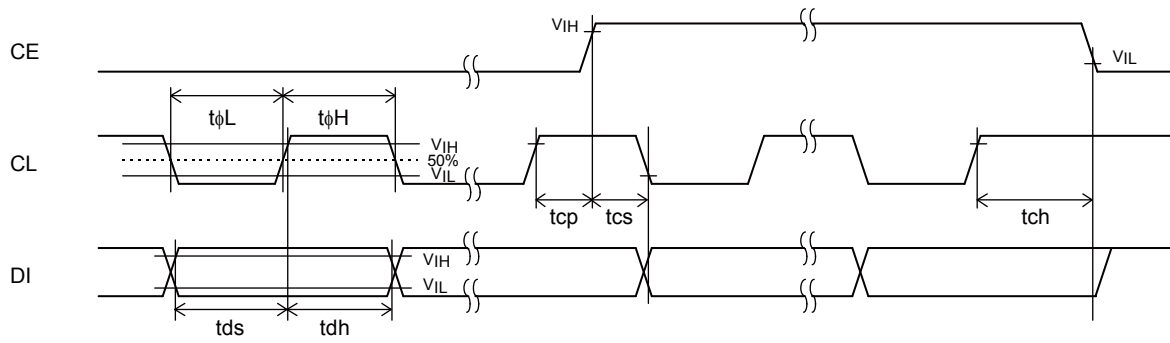
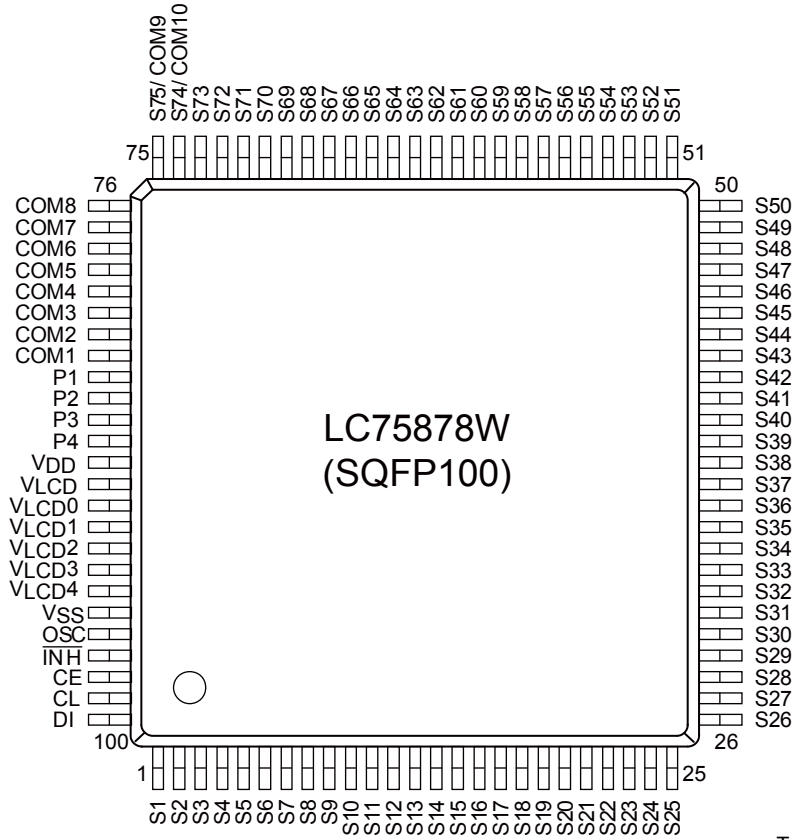

Figure 2

LC75878W

Pin Assignment



Top view

Block Diagram

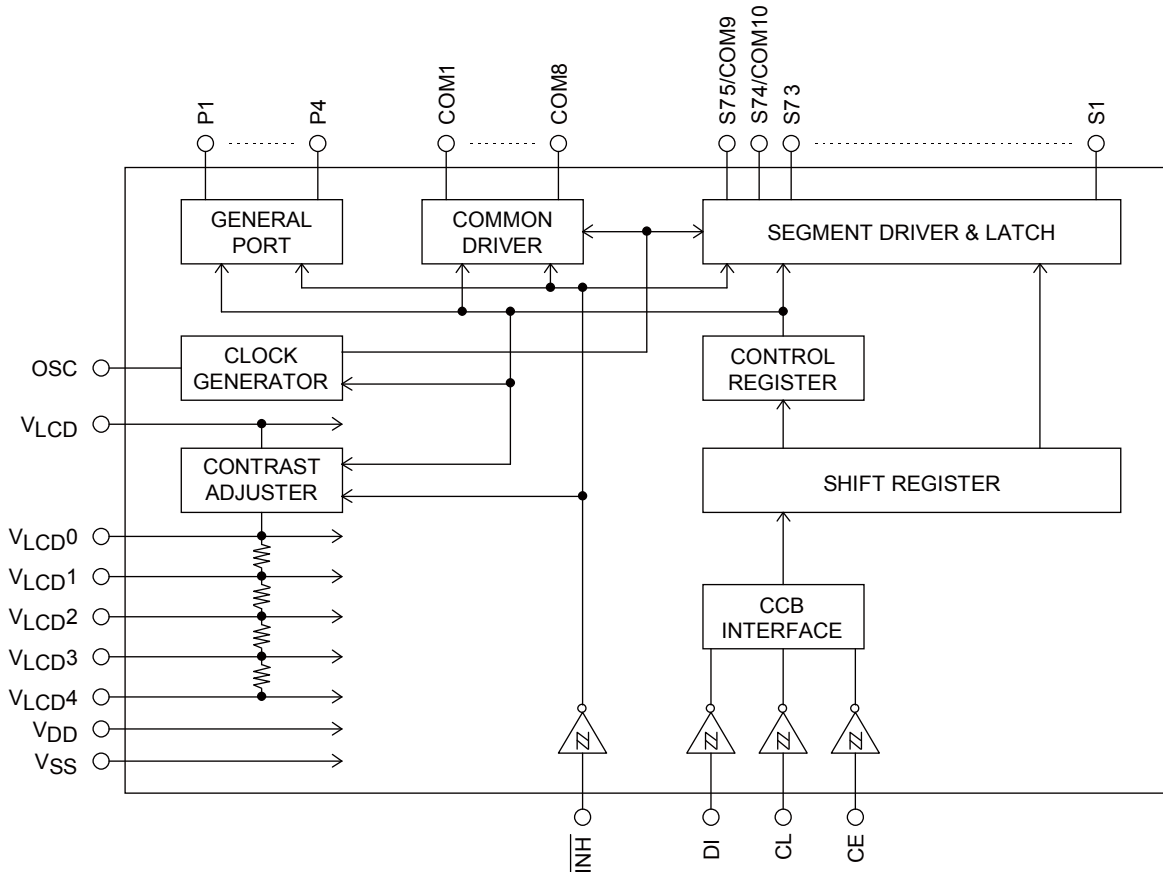

LC75878W

Pin Functions

Symbol	Pin No.	Function	Active	I/O	Handling when unused
S1 to S73 S74/COM10 S75/COM9	1 to 73 74 75	Segment driver outputs. The S74/COM10 and S75/COM9 pins can be used as common driver outputs under the control data.	-	O	OPEN
COM1 to COM8	83 to 76	Common driver outputs.	-	O	OPEN
P1 to P4	84 to 87	General-purpose output ports.	-	O	OPEN
OSC	96	Oscillator connection. An oscillator circuit is formed by connecting an external resistor and capacitor at this pin.	-	I/O	V _{DD}
CE	98	Serial data transfer inputs. These pins are connected to the microcontroller. CE: Chip enable CL: Synchronization clock DI: Transfer data	H	I	GND
CL	99			I	
DI	100		-	I	
$\overline{\text{INH}}$	97	Input that turns the display off and forces the general-purpose output ports low. • When $\overline{\text{INH}}$ is low (V _{SS}) • Display off S1 to S73 = "L" (V _{LCD4}). S74/COM10, S75/COM9 = "L" (V _{LCD4}) COM1 to COM8 = "L" (V _{LCD4}). • General-purpose output ports P1 to P4 = low (V _{SS}) • When $\overline{\text{INH}}$ is high (V _{DD}) • Display on • The states of the general-purpose output ports can be set by the PC1 to PC4 control data. However, serial data can be transferred when the $\overline{\text{INH}}$ pin is low.	L	I	GND
V _{LCD0}	90	LCD drive 4/4 bias voltage (high level) supply pin. The level on this pin can be changed by the display contrast adjustment circuit. However, (V _{LCD0} - V _{LCD4}) must be greater than or equal to 4.5 V. Also, external power must not be applied to this pin since the pin circuit includes the display contrast adjustment circuit.	-	O	OPEN
V _{LCD1}	91	LCD drive 3/4 bias voltage (middle level) supply pin. This pin can be used to supply the 3/4 (V _{LCD0} - V _{LCD4}) voltage level externally.	-	I	OPEN
V _{LCD2}	92	LCD drive 2/4 bias voltage (middle level) supply pin. This pin can be used to supply the 2/4 (V _{LCD0} - V _{LCD4}) voltage level externally.	-	I	OPEN
V _{LCD3}	93	LCD drive 1/4 bias voltage (middle level) supply pin. This pin can be used to supply the 1/4 (V _{LCD0} - V _{LCD4}) voltage level externally.	-	I	OPEN
V _{LCD4}	94	LCD drive 0/4 bias voltage (low level) supply pin. Fine adjustment of the display contrast can be implemented by connecting an external variable resistor to this pin. However, (V _{LCD0} - V _{LCD4}) must be greater than or equal to 4.5 V, and V _{LCD4} must be in the range 0 V to 1.5 V, inclusive.	-	I	GND
V _{DD}	88	Logic block power supply connection. Provide a voltage of between 2.7 and 6.0V.	-	-	-
V _{LCD}	89	LCD driver block power supply connection. Provide a voltage of between 7.0 and 11.0 V when the display contrast adjustment circuit is used and provide a voltage of between 4.5 and 11.0 V when the circuit is not used.	-	-	-
V _{SS}	95	Power supply connection. Connect to ground.	-	-	-

Serial Data Transfer Format

- 1. 1/8 duty
- (1) When CL is stopped at the low level
- When the display data is transferred.

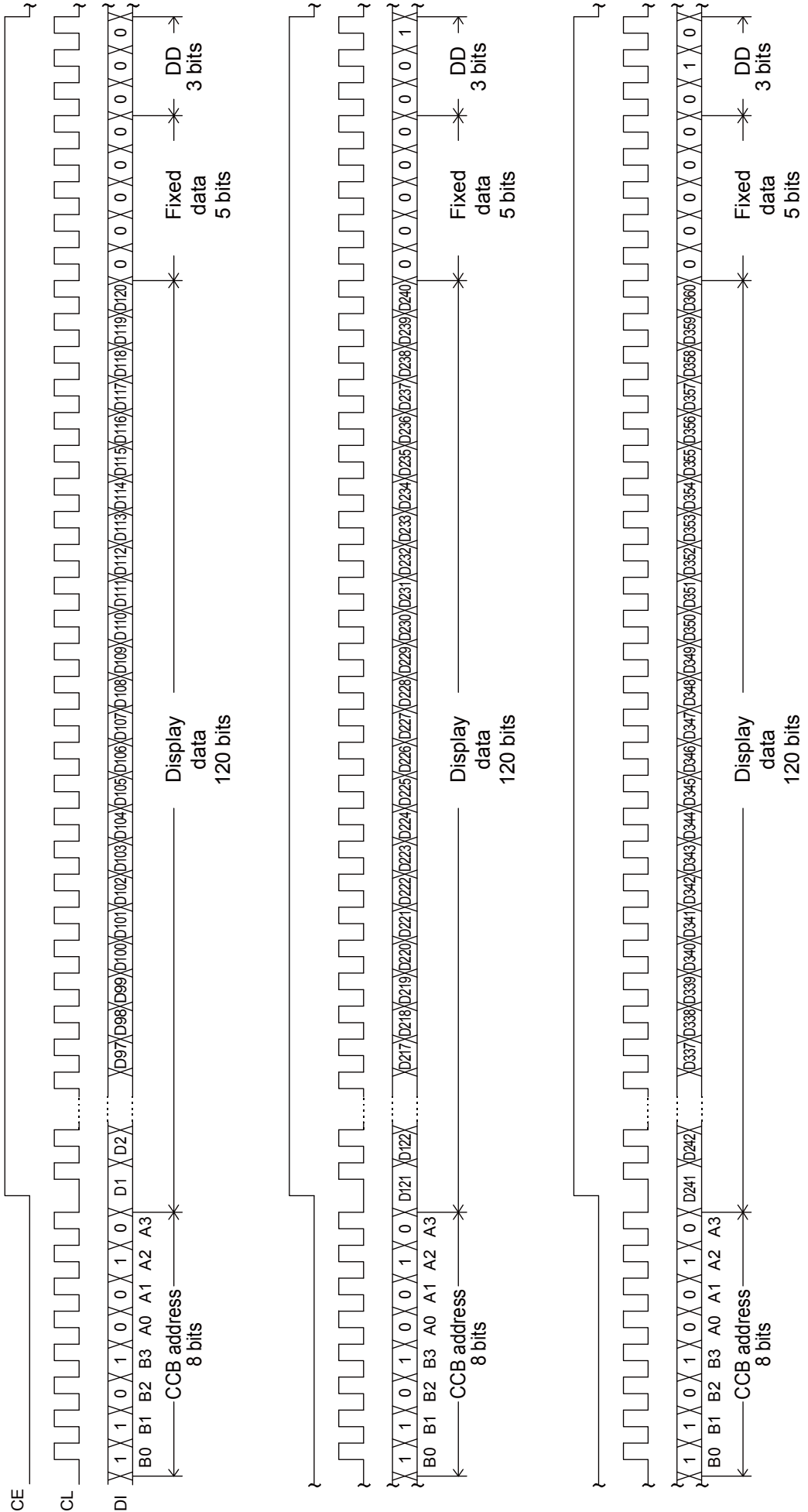

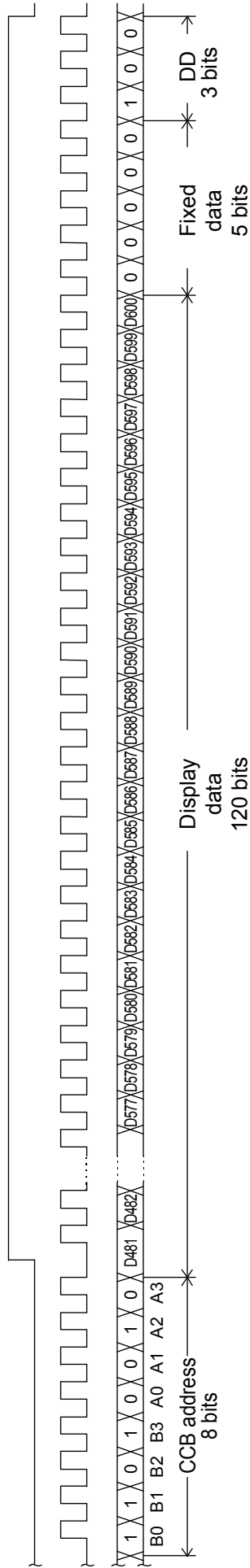
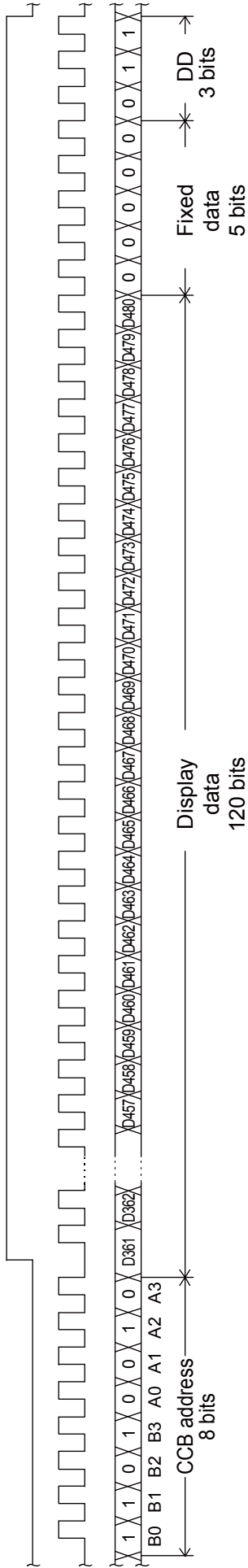

• When the control data is transferred.

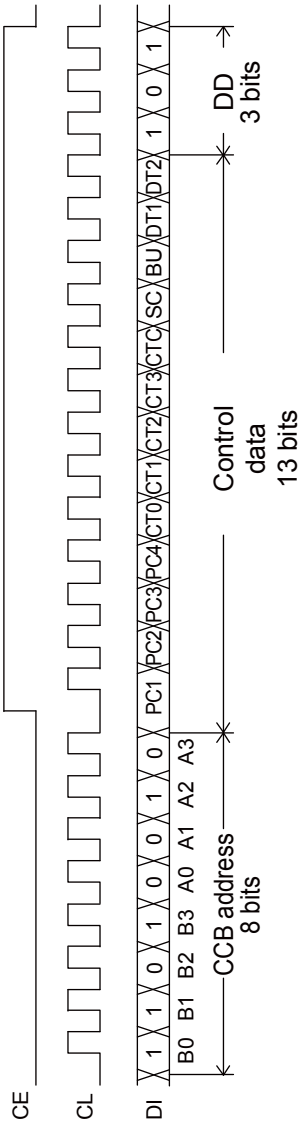

Note: B0 to B3, A0 to A3 CCB address
DD Direction data

- (2) When CL is stopped at the high level
- When the display data is transferred.

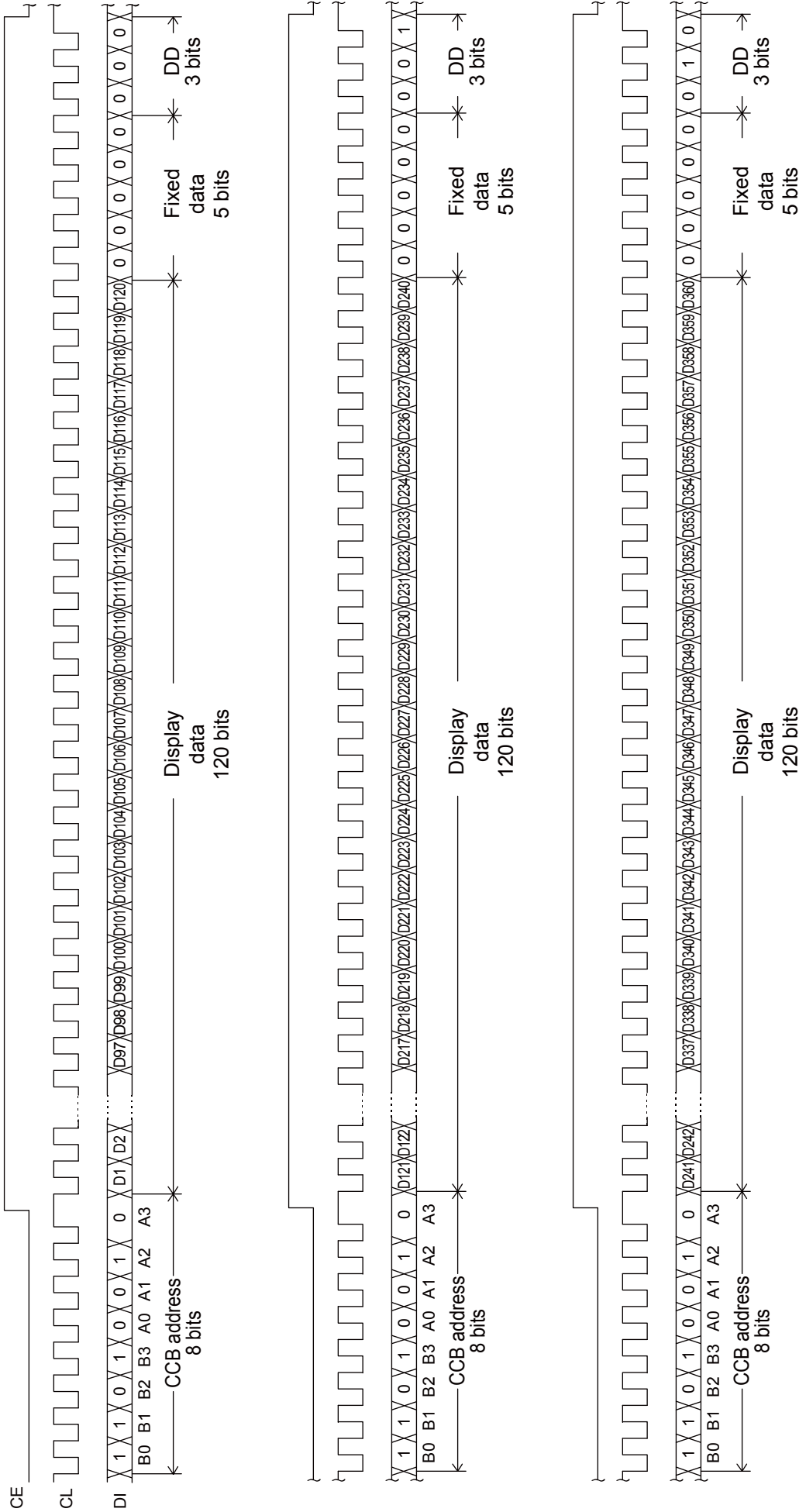

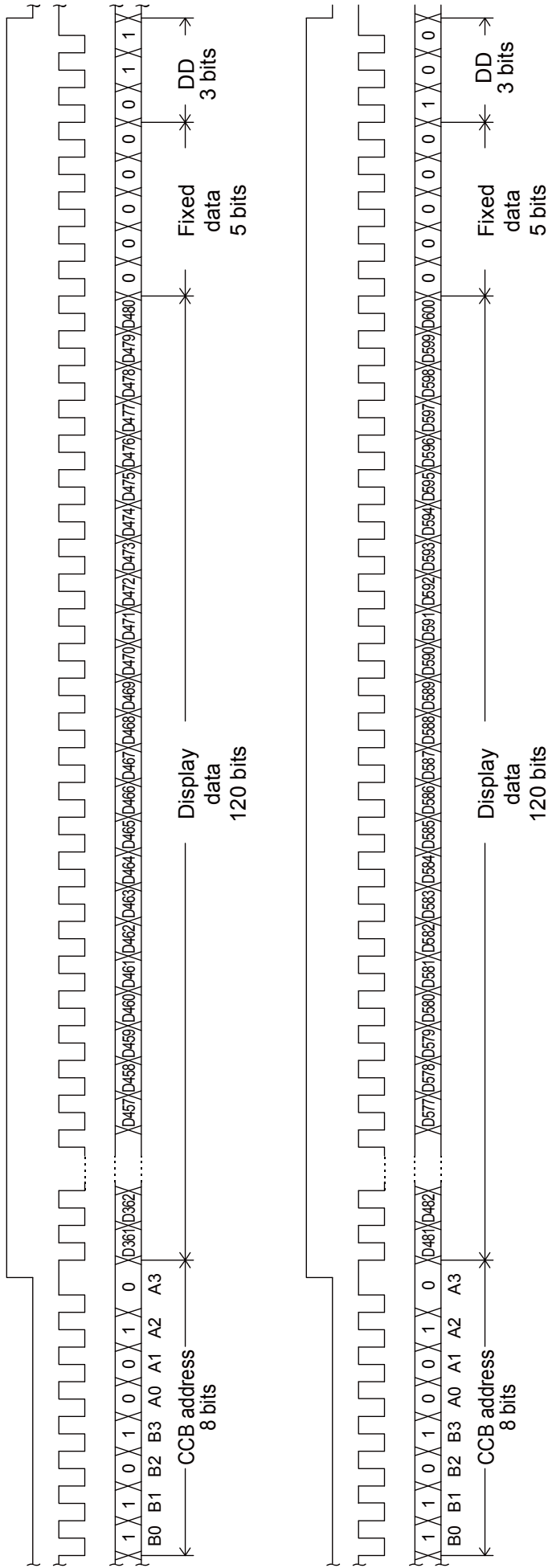

• When the control data is transferred.

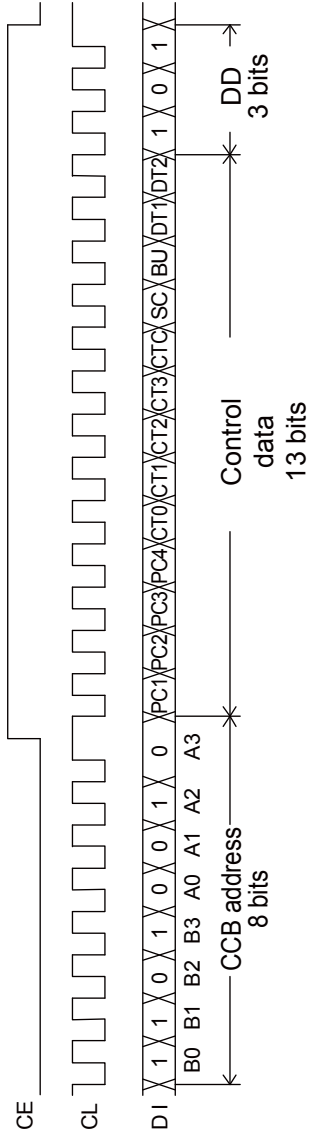

- Note: B0 to B3, A0 to A3 CCB address
 DD..... Direction data
 • CCB address: 4BH
 • D1 to D600: Display data
 • PC1 to PC4: General-purpose output port state setting data
 • CT0 to CT3, CTC: Display contrast setting data
 • SC: Segment on/off control data
 • BU: Normal mode/power saving mode control data
 • DT1, DT2:..... Display technique setting data

2. 1/9 duty

(1) When CL is stopped at the low level

- When the display data is transferred.

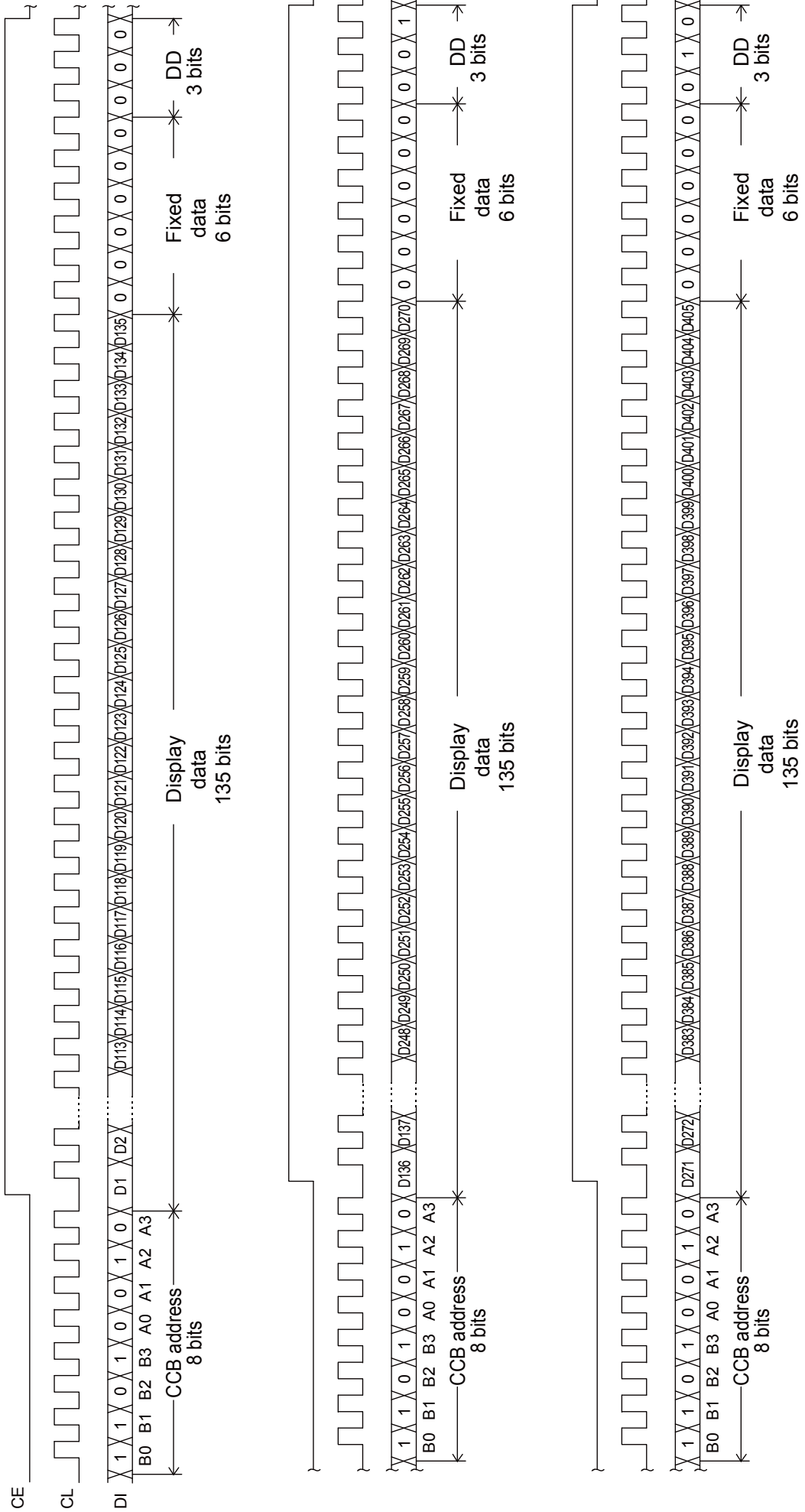

- (2) When CL is stopped at the high level
- When the display data is transferred.

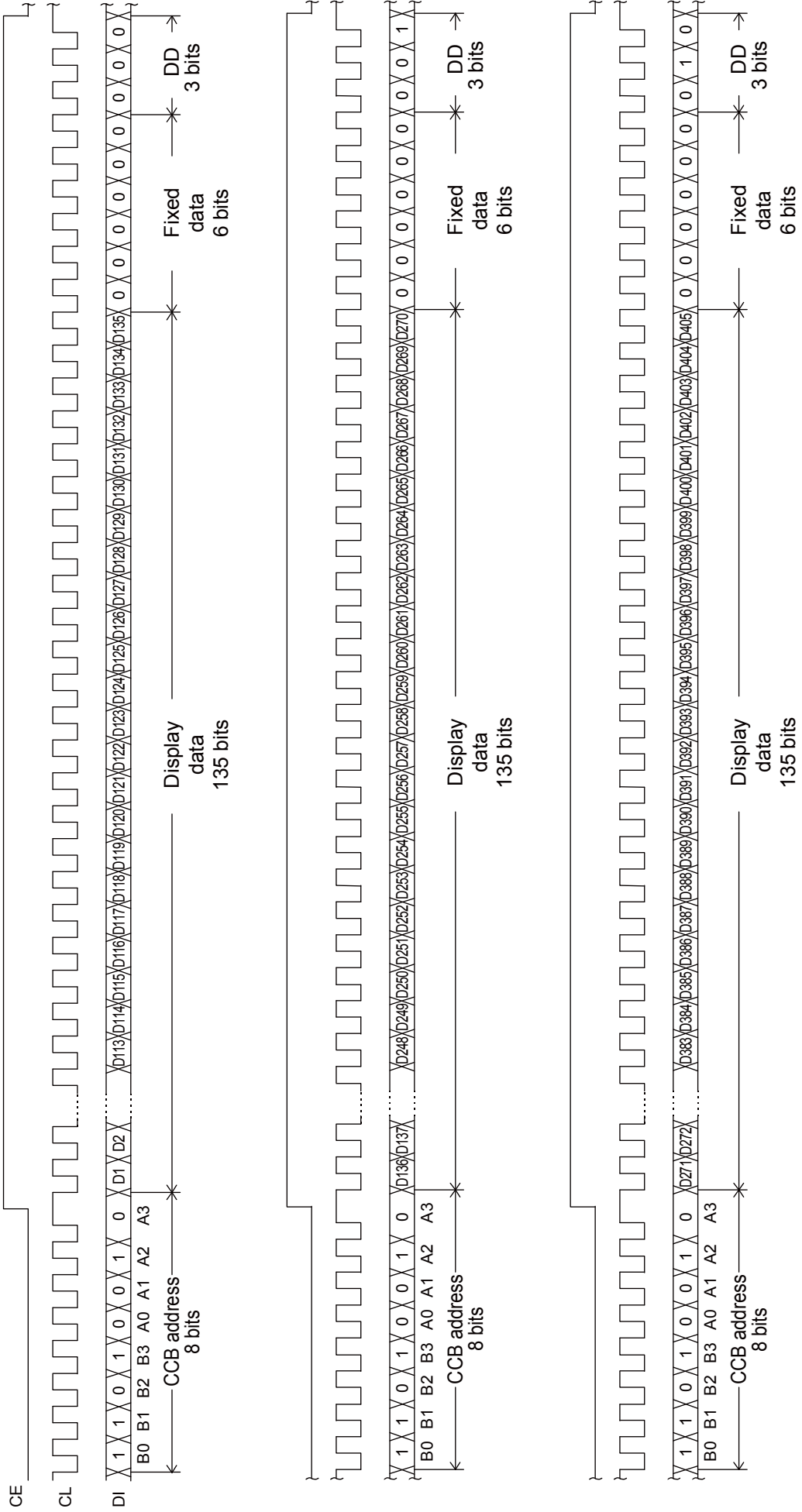

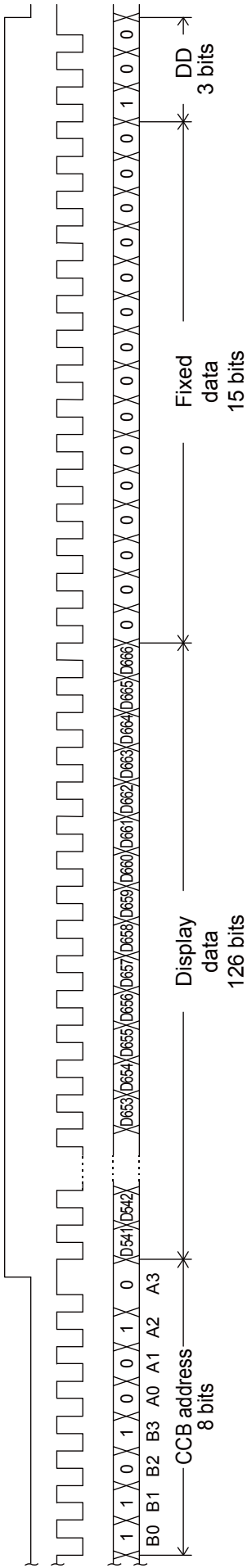
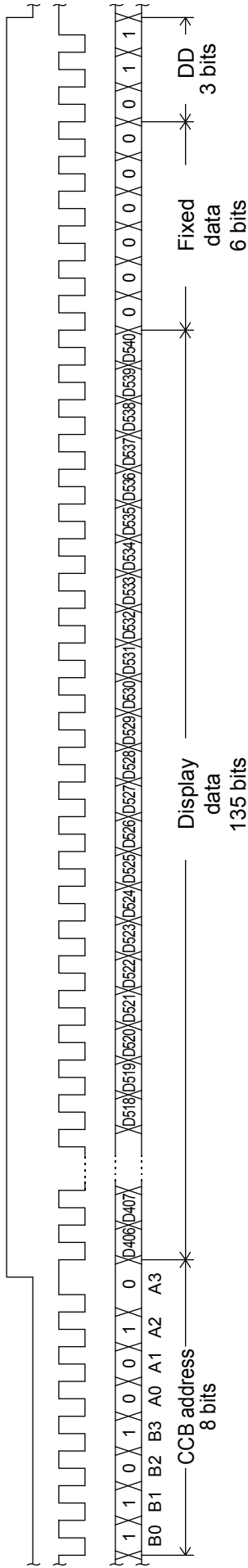

• When the control data is transferred.

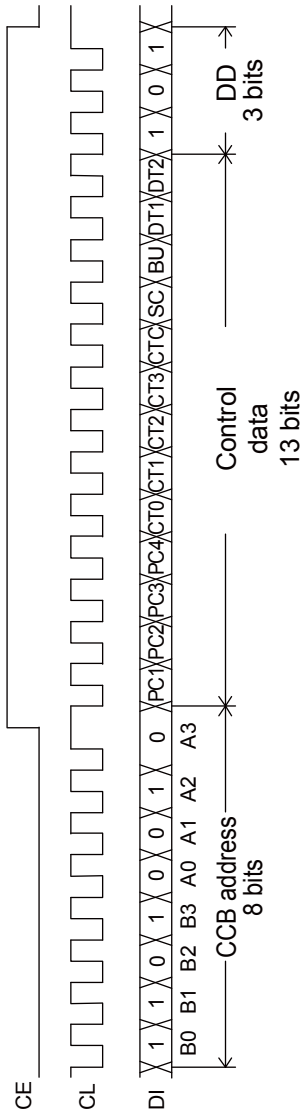

- Note: B0 to B3, A0 to A3 CCB address
- DD: Direction data
 - CCB address: 4BH
 - D1 to D666: Display data
 - PC1 to PC4: General-purpose output port state setting data
 - CT0 to CT3, CTC: Display contrast setting data
 - SC: Segment on/off control data
 - BU: Normal mode/power saving mode control data
 - DT1, DT2: Display technique setting data

3. 1/10 duty

- (1) When CL is stopped at the low level
 • When the display data is transferred.

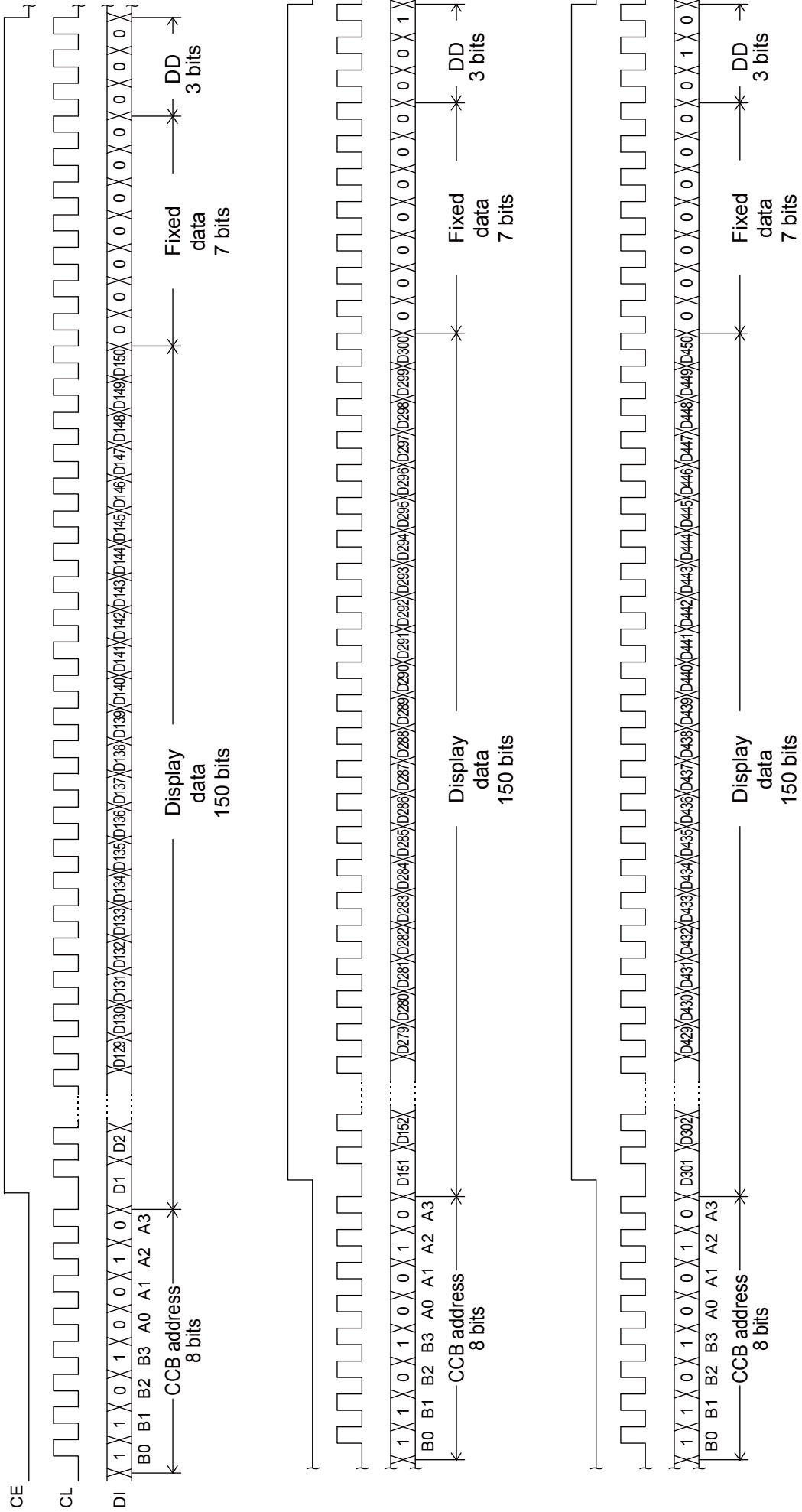

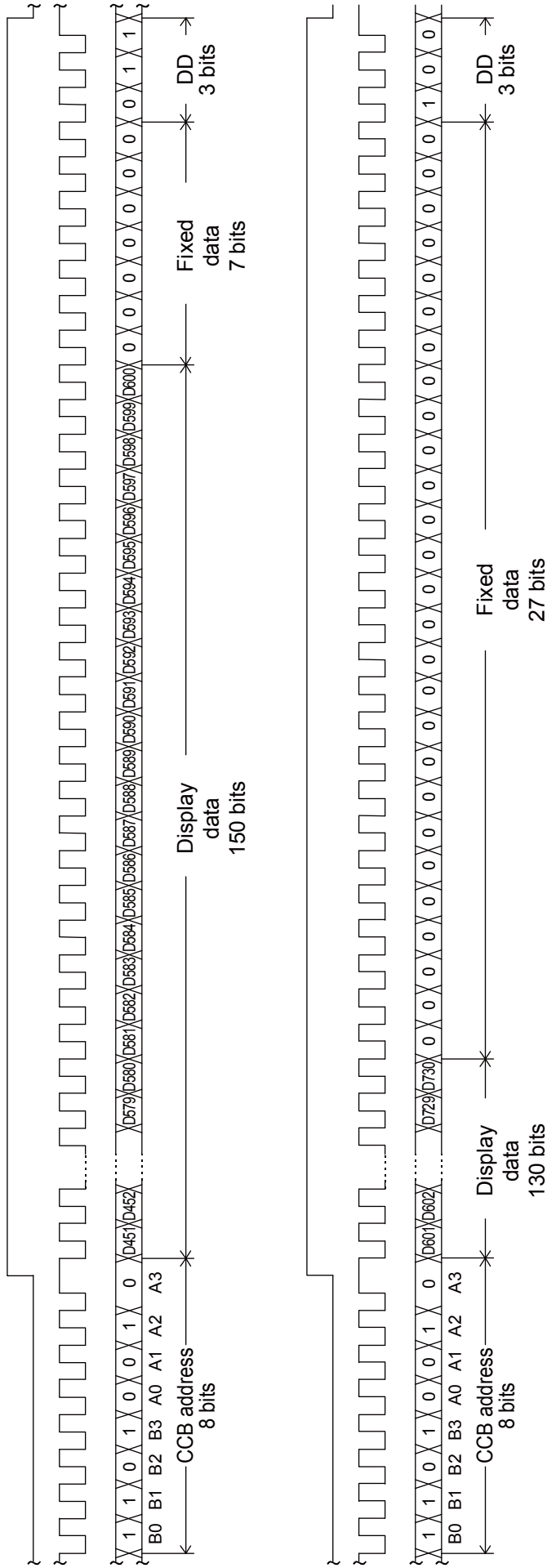

• When the control data is transferred.

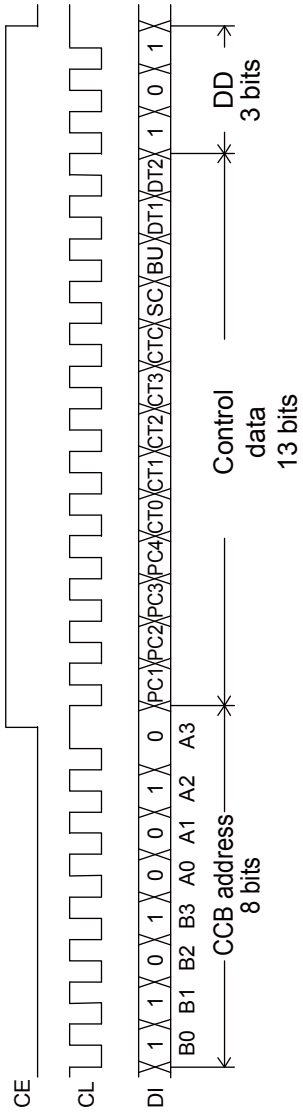

Note: B0 to B3, A0 to A3 CCB address
 DD Direction data
 . CCB address: 4BH
 . D1 to D730: Display data
 . PC1 to PC4: General-purpose output port state setting data
 . CT0 to CT3, CTC: Display contrast setting data
 . SC: Segment on/off control data
 . BU: Normal mode/power saving mode control data
 . DT1, DT2:..... Display technique setting data

Control Data Functions

1. PC1 to PC4: General-purpose output port state setting data

These control data bits set the states of the general-purpose output ports P1 to P4.

Output pin	P1	P2	P3	P4
General-purpose output port state setting data	PC1	PC2	PC3	PC4

For example, if PC1 and PC2 are set to 1, and PC3 and PC4 are set to 0, then the output pins P1 and P2 will output high levels (V_{DD}) and the output pins P3 and P4 will output low levels (V_{SS}).

2. CT0 to CT3, CTC: Display contrast setting data

These control data bits set the display contrast.

CT0 to CT3: Display contrast setting (11 steps)

CT0	CT1	CT2	CT3	LCD drive 4/4 bias voltage supply V_{LCD0} level
0	0	0	0	$0.94V_{LCD}=V_{LCD}-(0.03V_{LCD}\times 2)$
1	0	0	0	$0.91V_{LCD}=V_{LCD}-(0.03V_{LCD}\times 3)$
0	1	0	0	$0.88V_{LCD}=V_{LCD}-(0.03V_{LCD}\times 4)$
1	1	0	0	$0.85V_{LCD}=V_{LCD}-(0.03V_{LCD}\times 5)$
0	0	1	0	$0.82V_{LCD}=V_{LCD}-(0.03V_{LCD}\times 6)$
1	0	1	0	$0.79V_{LCD}=V_{LCD}-(0.03V_{LCD}\times 7)$
0	1	1	0	$0.76V_{LCD}=V_{LCD}-(0.03V_{LCD}\times 8)$
1	1	1	0	$0.73V_{LCD}=V_{LCD}-(0.03V_{LCD}\times 9)$
0	0	0	1	$0.70V_{LCD}=V_{LCD}-(0.03V_{LCD}\times 10)$
1	0	0	1	$0.67V_{LCD}=V_{LCD}-(0.03V_{LCD}\times 11)$
0	1	0	1	$0.64V_{LCD}=V_{LCD}-(0.03V_{LCD}\times 12)$

CTC: Display contrast adjustment circuit state setting

CTC	Display contrast adjustment circuit state
0	The display contrast adjustment circuit is disabled, and the V_{LCD0} pin level is forced to the V_{LCD} level.
1	The display contrast adjustment circuit operates and the display contrast is adjusted.

Note that although the display contrast can be adjusted by operating the built-in display contrast adjustment circuit, it is also possible to apply fine adjustments to the contrast by connecting an external variable resistor to the V_{LCD4} pin and modifying the V_{LCD4} pin voltage. However, the following conditions must be met: $(V_{LCD0} - V_{LCD4}) \geq 4.5 V$, and $1.5 V \geq V_{LCD4} \geq 0 V$.

3. SC: Segment on/off control data

This control data bit controls the on/off state of the segments.

SC	Display state
0	On
1	Off

However, note that when the segments are turned off by setting SC to 1, the segments are turned off by outputting segment off waveforms from the segment output pins.

LC75878W

4. BU: Normal mode/power saving mode control data

This control data bit controls the normal mode and power saving mode.

BU	Mode
0	Normal mode
1	Power-saving mode. The common and segment pins go to the V_{LCD4} level and the oscillator on the OSC pin is stopped. Note that the states of the general-purpose output ports P1 to P4 are set by PC1 to PC4 in the control data during power saving mode as well as normal mode.

5. DT1, DT2: Display technique setting data

This control data bits set the display technique.

DT1	DT2	Display technique	Output pins	
			S75/COM9	S74/COM10
0	0	1/8 duty 1/4 bias drive	S75	S74
1	0	1/9 duty 1/4 bias drive	COM9	S74
0	1	1/10 duty 1/4 bias drive	COM9	COM10

Notes: Sn (n = 74 or 75): Segment outputs

COMn (n = 9 or 10): Common outputs

LC75878W

Display Data and Output Pin Correspondence

• 1/8 duty

Output Pin	COM1	COM2	COM3	COM4	COM5	COM6	COM7	COM8
S1	D1	D2	D3	D4	D5	D6	D7	D8
S2	D9	D10	D11	D12	D13	D14	D15	D16
S3	D17	D18	D19	D20	D21	D22	D23	D24
S4	D25	D26	D27	D28	D29	D30	D31	D32
S5	D33	D34	D35	D36	D37	D38	D39	D40
S6	D41	D42	D43	D44	D45	D46	D47	D48
S7	D49	D50	D51	D52	D53	D54	D55	D56
S8	D57	D58	D59	D60	D61	D62	D63	D64
S9	D65	D66	D67	D68	D69	D70	D71	D72
S10	D73	D74	D75	D76	D77	D78	D79	D80
S11	D81	D82	D83	D84	D85	D86	D87	D88
S12	D89	D90	D91	D92	D93	D94	D95	D96
S13	D97	D98	D99	D100	D101	D102	D103	D104
S14	D105	D106	D107	D108	D109	D110	D111	D112
S15	D113	D114	D115	D116	D117	D118	D119	D120
S16	D121	D122	D123	D124	D125	D126	D127	D128
S17	D129	D130	D131	D132	D133	D134	D135	D136
S18	D137	D138	D139	D140	D141	D142	D143	D144
S19	D145	D146	D147	D148	D149	D150	D151	D152
S20	D153	D154	D155	D156	D157	D158	D159	D160
S21	D161	D162	D163	D164	D165	D166	D167	D168
S22	D169	D170	D171	D172	D173	D174	D175	D176
S23	D177	D178	D179	D180	D181	D182	D183	D184
S24	D185	D186	D187	D188	D189	D190	D191	D192
S25	D193	D194	D195	D196	D197	D198	D199	D200
S26	D201	D202	D203	D204	D205	D206	D207	D208
S27	D209	D210	D211	D212	D213	D214	D215	D216
S28	D217	D218	D219	D220	D221	D222	D223	D224
S29	D225	D226	D227	D228	D229	D230	D231	D232
S30	D233	D234	D235	D236	D237	D238	D239	D240
S31	D241	D242	D243	D244	D245	D246	D247	D248
S32	D249	D250	D251	D252	D253	D254	D255	D256
S33	D257	D258	D259	D260	D261	D262	D263	D264
S34	D265	D266	D267	D268	D269	D270	D271	D272
S35	D273	D274	D275	D276	D277	D278	D279	D280
S36	D281	D282	D283	D284	D285	D286	D287	D288
S37	D289	D290	D291	D292	D293	D294	D295	D296
S38	D297	D298	D299	D300	D301	D302	D303	D304
S39	D305	D306	D307	D308	D309	D310	D311	D312
S40	D313	D314	D315	D316	D317	D318	D319	D320
S41	D321	D322	D323	D324	D325	D326	D327	D328
S42	D329	D330	D331	D332	D333	D334	D335	D336
S43	D337	D338	D339	D340	D341	D342	D343	D344
S44	D345	D346	D347	D348	D349	D350	D351	D352
S45	D353	D354	D355	D356	D357	D358	D359	D360

Continued on next page.

LC75878W

Continued from preceding page.

Output Pin	COM1	COM2	COM3	COM4	COM5	COM6	COM7	COM8
S46	D361	D362	D363	D364	D365	D366	D367	D368
S47	D369	D370	D371	D372	D373	D374	D375	D376
S48	D377	D378	D379	D380	D381	D382	D383	D384
S49	D385	D386	D387	D388	D389	D390	D391	D392
S50	D393	D394	D395	D396	D397	D398	D399	D400
S51	D401	D402	D403	D404	D405	D406	D407	D408
S52	D409	D410	D411	D412	D413	D414	D415	D416
S53	D417	D418	D419	D420	D421	D422	D423	D424
S54	D425	D426	D427	D428	D429	D430	D431	D432
S55	D433	D434	D435	D436	D437	D438	D439	D440
S56	D441	D442	D443	D444	D445	D446	D447	D448
S57	D449	D450	D451	D452	D453	D454	D455	D456
S58	D457	D458	D459	D460	D461	D462	D463	D464
S59	D465	D466	D467	D468	D469	D470	D471	D472
S60	D473	D474	D475	D476	D477	D478	D479	D480
S61	D481	D482	D483	D484	D485	D486	D487	D488
S62	D489	D490	D491	D492	D493	D494	D495	D496
S63	D497	D498	D499	D500	D501	D502	D503	D504
S64	D505	D506	D507	D508	D509	D510	D511	D512
S65	D513	D514	D515	D516	D517	D518	D519	D520
S66	D521	D522	D523	D524	D525	D526	D527	D528
S67	D529	D530	D531	D532	D533	D534	D535	D536
S68	D537	D538	D539	D540	D541	D542	D543	D544
S69	D545	D546	D547	D548	D549	D550	D551	D552
S70	D553	D554	D555	D556	D557	D558	D559	D560
S71	D561	D562	D563	D564	D565	D566	D567	D568
S72	D569	D570	D571	D572	D573	D574	D575	D576
S73	D577	D578	D579	D580	D581	D582	D583	D584
S74/COM10	D585	D586	D587	D588	D589	D590	D591	D592
S75/COM9	D593	D594	D595	D596	D597	D598	D599	D600

Note: Applies when the S74/COM10 and S75/COM9 output pins are set to their segment output function.

For example, the table below lists the segment output states for the S11 output pin.

Display data								Output pin state (S11)
D81	D82	D83	D84	D85	D86	D87	D88	
0	0	0	0	0	0	0	0	The LCD segments for COM1 to COM8 are off
1	0	0	0	0	0	0	0	The LCD segment for COM1 is on
0	1	0	0	0	0	0	0	The LCD segment for COM2 is on
0	0	1	0	0	0	0	0	The LCD segment for COM3 is on
0	0	0	1	0	0	0	0	The LCD segment for COM4 is on
0	0	0	0	1	0	0	0	The LCD segment for COM5 is on
0	0	0	0	0	1	0	0	The LCD segment for COM6 is on
0	0	0	0	0	0	1	0	The LCD segment for COM7 is on
0	0	0	0	0	0	0	1	The LCD segment for COM8 is on
1	1	1	1	1	1	1	1	The LCD segments for COM1 to COM8 are on

LC75878W

• 1/9 duty

Output Pin	COM1	COM2	COM3	COM4	COM5	COM6	COM7	COM8	COM9
S1	D1	D2	D3	D4	D5	D6	D7	D8	D9
S2	D10	D11	D12	D13	D14	D15	D16	D17	D18
S3	D19	D20	D21	D22	D23	D24	D25	D26	D27
S4	D28	D29	D30	D31	D32	D33	D34	D35	D36
S5	D37	D38	D39	D40	D41	D42	D43	D44	D45
S6	D46	D47	D48	D49	D50	D51	D52	D53	D54
S7	D55	D56	D57	D58	D59	D60	D61	D62	D63
S8	D64	D65	D66	D67	D68	D69	D70	D71	D72
S9	D73	D74	D75	D76	D77	D78	D79	D80	D81
S10	D82	D83	D84	D85	D86	D87	D88	D89	D90
S11	D91	D92	D93	D94	D95	D96	D97	D98	D99
S12	D100	D101	D102	D103	D104	D105	D106	D107	D108
S13	D109	D110	D111	D112	D113	D114	D115	D116	D117
S14	D118	D119	D120	D121	D122	D123	D124	D125	D126
S15	D127	D128	D129	D130	D131	D132	D133	D134	D135
S16	D136	D137	D138	D139	D140	D141	D142	D143	D144
S17	D145	D146	D147	D148	D149	D150	D151	D152	D153
S18	D154	D155	D156	D157	D158	D159	D160	D161	D162
S19	D163	D164	D165	D166	D167	D168	D169	D170	D171
S20	D172	D173	D174	D175	D176	D177	D178	D179	D180
S21	D181	D182	D183	D184	D185	D186	D187	D188	D189
S22	D190	D191	D192	D193	D194	D195	D196	D197	D198
S23	D199	D200	D201	D202	D203	D204	D205	D206	D207
S24	D208	D209	D210	D211	D212	D213	D214	D215	D216
S25	D217	D218	D219	D220	D221	D222	D223	D224	D225
S26	D226	D227	D228	D229	D230	D231	D232	D233	D234
S27	D235	D236	D237	D238	D239	D240	D241	D242	D243
S28	D244	D245	D246	D247	D248	D249	D250	D251	D252
S29	D253	D254	D255	D256	D257	D258	D259	D260	D261
S30	D262	D263	D264	D265	D266	D267	D268	D269	D270
S31	D271	D272	D273	D274	D275	D276	D277	D278	D279
S32	D280	D281	D282	D283	D284	D285	D286	D287	D288
S33	D289	D290	D291	D292	D293	D294	D295	D296	D297
S34	D298	D299	D300	D301	D302	D303	D304	D305	D306
S35	D307	D308	D309	D310	D311	D312	D313	D314	D315
S36	D316	D317	D318	D319	D320	D321	D322	D323	D324
S37	D325	D326	D327	D328	D329	D330	D331	D332	D333
S38	D334	D335	D336	D337	D338	D339	D340	D341	D342
S39	D343	D344	D345	D346	D347	D348	D349	D350	D351
S40	D352	D353	D354	D355	D356	D357	D358	D359	D360
S41	D361	D362	D363	D364	D365	D366	D367	D368	D369
S42	D370	D371	D372	D373	D374	D375	D376	D377	D378
S43	D379	D380	D381	D382	D383	D384	D385	D386	D387
S44	D388	D389	D390	D391	D392	D393	D394	D395	D396
S45	D397	D398	D399	D400	D401	D402	D403	D404	D405

Continued on next page.

LC75878W

Continued from preceding page.

Output Pin	COM1	COM2	COM3	COM4	COM5	COM6	COM7	COM8	COM9
S46	D406	D407	D408	D409	D410	D411	D412	D413	D414
S47	D415	D416	D417	D418	D419	D420	D421	D422	D423
S48	D424	D425	D426	D427	D428	D429	D430	D431	D432
S49	D433	D434	D435	D436	D437	D438	D439	D440	D441
S50	D442	D443	D444	D445	D446	D447	D448	D449	D450
S51	D451	D452	D453	D454	D455	D456	D457	D458	D459
S52	D460	D461	D462	D463	D464	D465	D466	D467	D468
S53	D469	D470	D471	D472	D473	D474	D475	D476	D477
S54	D478	D479	D480	D481	D482	D483	D484	D485	D486
S55	D487	D488	D489	D490	D491	D492	D493	D494	D495
S56	D496	D497	D498	D499	D500	D501	D502	D503	D504
S57	D505	D506	D507	D508	D509	D510	D511	D512	D513
S58	D514	D515	D516	D517	D518	D519	D520	D521	D522
S59	D523	D524	D525	D526	D527	D528	D529	D530	D531
S60	D532	D533	D534	D535	D536	D537	D538	D539	D540
S61	D541	D542	D543	D544	D545	D546	D547	D548	D549
S62	D550	D551	D552	D553	D554	D555	D556	D557	D558
S63	D559	D560	D561	D562	D563	D564	D565	D566	D567
S64	D568	D569	D570	D571	D572	D573	D574	D575	D576
S65	D577	D578	D579	D580	D581	D582	D583	D584	D585
S66	D586	D587	D588	D589	D590	D591	D592	D593	D594
S67	D595	D596	D597	D598	D599	D600	D601	D602	D603
S68	D604	D605	D606	D607	D608	D609	D610	D611	D612
S69	D613	D614	D615	D616	D617	D618	D619	D620	D621
S70	D622	D623	D624	D625	D626	D627	D628	D629	D630
S71	D631	D632	D633	D634	D635	D636	D637	D638	D639
S72	D640	D641	D642	D643	D644	D645	D646	D647	D648
S73	D649	D650	D651	D652	D653	D654	D655	D656	D657
S74/COM10	D658	D659	D660	D661	D662	D663	D664	D665	D666

Note: Applies when the S74/COM10 output pin is set to its segment output function.

For example, the table below lists the segment output states for the S11 output pin.

Display data									Output pin state (S11)
D91	D92	D93	D94	D95	D96	D97	D98	D99	
0	0	0	0	0	0	0	0	0	The LCD segments for COM1 to COM9 are off
1	0	0	0	0	0	0	0	0	The LCD segment for COM1 is on
0	1	0	0	0	0	0	0	0	The LCD segment for COM2 is on
0	0	1	0	0	0	0	0	0	The LCD segment for COM3 is on
0	0	0	1	0	0	0	0	0	The LCD segment for COM4 is on
0	0	0	0	1	0	0	0	0	The LCD segment for COM5 is on
0	0	0	0	0	1	0	0	0	The LCD segment for COM6 is on
0	0	0	0	0	0	1	0	0	The LCD segment for COM7 is on
0	0	0	0	0	0	0	1	0	The LCD segment for COM8 is on
0	0	0	0	0	0	0	0	1	The LCD segment for COM9 is on
1	1	1	1	1	1	1	1	1	The LCD segments for COM1 to COM9 are on

LC75878W

• 1/10 duty

Output Pin	COM1	COM2	COM3	COM4	COM5	COM6	COM7	COM8	COM9	COM10
S1	D1	D2	D3	D4	D5	D6	D7	D8	D9	D10
S2	D11	D12	D13	D14	D15	D16	D17	D18	D19	D20
S3	D21	D22	D23	D24	D25	D26	D27	D28	D29	D30
S4	D31	D32	D33	D34	D35	D36	D37	D38	D39	D40
S5	D41	D42	D43	D44	D45	D46	D47	D48	D49	D50
S6	D51	D52	D53	D54	D55	D56	D57	D58	D59	D60
S7	D61	D62	D63	D64	D65	D66	D67	D68	D69	D70
S8	D71	D72	D73	D74	D75	D76	D77	D78	D79	D80
S9	D81	D82	D83	D84	D85	D86	D87	D88	D89	D90
S10	D91	D92	D93	D94	D95	D96	D97	D98	D99	D100
S11	D101	D102	D103	D104	D105	D106	D107	D108	D109	D110
S12	D111	D112	D113	D114	D115	D116	D117	D118	D119	D120
S13	D121	D122	D123	D124	D125	D126	D127	D128	D129	D130
S14	D131	D132	D133	D134	D135	D136	D137	D138	D139	D140
S15	D141	D142	D143	D144	D145	D146	D147	D148	D149	D150
S16	D151	D152	D153	D154	D155	D156	D157	D158	D159	D160
S17	D161	D162	D163	D164	D165	D166	D167	D168	D169	D170
S18	D171	D172	D173	D174	D175	D176	D177	D178	D179	D180
S19	D181	D182	D183	D184	D185	D186	D187	D188	D189	D190
S20	D191	D192	D193	D194	D195	D196	D197	D198	D199	D200
S21	D201	D202	D203	D204	D205	D206	D207	D208	D209	D210
S22	D211	D212	D213	D214	D215	D216	D217	D218	D219	D220
S23	D221	D222	D223	D224	D225	D226	D227	D228	D229	D230
S24	D231	D232	D233	D234	D235	D236	D237	D238	D239	D240
S25	D241	D242	D243	D244	D245	D246	D247	D248	D249	D250
S26	D251	D252	D253	D254	D255	D256	D257	D258	D259	D260
S27	D261	D262	D263	D264	D265	D266	D267	D268	D269	D270
S28	D271	D272	D273	D274	D275	D276	D277	D278	D279	D280
S29	D281	D282	D283	D284	D285	D286	D287	D288	D289	D290
S30	D291	D292	D293	D294	D295	D296	D297	D298	D299	D300
S31	D301	D302	D303	D304	D305	D306	D307	D308	D309	D310
S32	D311	D312	D313	D314	D315	D316	D317	D318	D319	D320
S33	D321	D322	D323	D324	D325	D326	D327	D328	D329	D330
S34	D331	D332	D333	D334	D335	D336	D337	D338	D339	D340
S35	D341	D342	D343	D344	D345	D346	D347	D348	D349	D350
S36	D351	D352	D353	D354	D355	D356	D357	D358	D359	D360
S37	D361	D362	D363	D364	D365	D366	D367	D368	D369	D370
S38	D371	D372	D373	D374	D375	D376	D377	D378	D379	D380
S39	D381	D382	D383	D384	D385	D386	D387	D388	D389	D390
S40	D391	D392	D393	D394	D395	D396	D397	D398	D399	D400
S41	D401	D402	D403	D404	D405	D406	D407	D408	D409	D410
S42	D411	D412	D413	D414	D415	D416	D417	D418	D419	D420
S43	D421	D422	D423	D424	D425	D426	D427	D428	D429	D430
S44	D431	D432	D433	D434	D435	D436	D437	D438	D439	D440
S45	D441	D442	D443	D444	D445	D446	D447	D448	D449	D450

Continued on next page.

LC75878W

Continued from preceding page.

Output Pin	COM1	COM2	COM3	COM4	COM5	COM6	COM7	COM8	COM9	COM10
S46	D451	D452	D453	D454	D455	D456	D457	D458	D459	D460
S47	D461	D462	D463	D464	D465	D466	D467	D468	D469	D470
S48	D471	D472	D473	D474	D475	D476	D477	D478	D479	D480
S49	D481	D482	D483	D484	D485	D486	D487	D488	D489	D490
S50	D491	D492	D493	D494	D495	D496	D497	D498	D499	D500
S51	D501	D502	D503	D504	D505	D506	D507	D508	D509	D510
S52	D511	D512	D513	D514	D515	D516	D517	D518	D519	D520
S53	D521	D522	D523	D524	D525	D526	D527	D528	D529	D530
S54	D531	D532	D533	D534	D535	D536	D537	D538	D539	D540
S55	D541	D542	D543	D544	D545	D546	D547	D548	D549	D550
S56	D551	D552	D553	D554	D555	D556	D557	D558	D559	D560
S57	D561	D562	D563	D564	D565	D566	D567	D568	D569	D570
S58	D571	D572	D573	D574	D575	D576	D577	D578	D579	D580
S59	D581	D582	D583	D584	D585	D586	D587	D588	D589	D590
S60	D591	D592	D593	D594	D595	D596	D597	D598	D599	D600
S61	D601	D602	D603	D604	D605	D606	D607	D608	D609	D610
S62	D611	D612	D613	D614	D615	D616	D617	D618	D619	D620
S63	D621	D622	D623	D624	D625	D626	D627	D628	D629	D630
S64	D631	D632	D633	D634	D635	D636	D637	D638	D639	D640
S65	D641	D642	D643	D644	D645	D646	D647	D648	D649	D650
S66	D651	D652	D653	D654	D655	D656	D657	D658	D659	D660
S67	D661	D662	D663	D664	D665	D666	D667	D668	D669	D670
S68	D671	D672	D673	D674	D675	D676	D677	D678	D679	D680
S69	D681	D682	D683	D684	D685	D686	D687	D688	D689	D690
S70	D691	D692	D693	D694	D695	D696	D697	D698	D699	D700
S71	D701	D702	D703	D704	D705	D706	D707	D708	D709	D710
S72	D711	D712	D713	D714	D715	D716	D717	D718	D719	D720
S73	D721	D722	D723	D724	D725	D726	D727	D728	D729	D730

For example, the table below lists the segment output states for the S11 output pin.

Display data										Output pin state (S11)
D101	D102	D103	D104	D105	D106	D107	D108	D109	D110	
0	0	0	0	0	0	0	0	0	0	The LCD segments for COM1 to COM10 are off
1	0	0	0	0	0	0	0	0	0	The LCD segment for COM1 is on
0	1	0	0	0	0	0	0	0	0	The LCD segment for COM2 is on
0	0	1	0	0	0	0	0	0	0	The LCD segment for COM3 is on
0	0	0	1	0	0	0	0	0	0	The LCD segment for COM4 is on
0	0	0	0	1	0	0	0	0	0	The LCD segment for COM5 is on
0	0	0	0	0	1	0	0	0	0	The LCD segment for COM6 is on
0	0	0	0	0	0	1	0	0	0	The LCD segment for COM7 is on
0	0	0	0	0	0	0	1	0	0	The LCD segment for COM8 is on
0	0	0	0	0	0	0	0	1	0	The LCD segment for COM9 is on
0	0	0	0	0	0	0	0	0	1	The LCD segment for COM10 is on
1	1	1	1	1	1	1	1	1	1	The LCD segments for COM1 to COM10 are on

LC75878W

1/8 Duty, 1/4 Bias Drive Technique

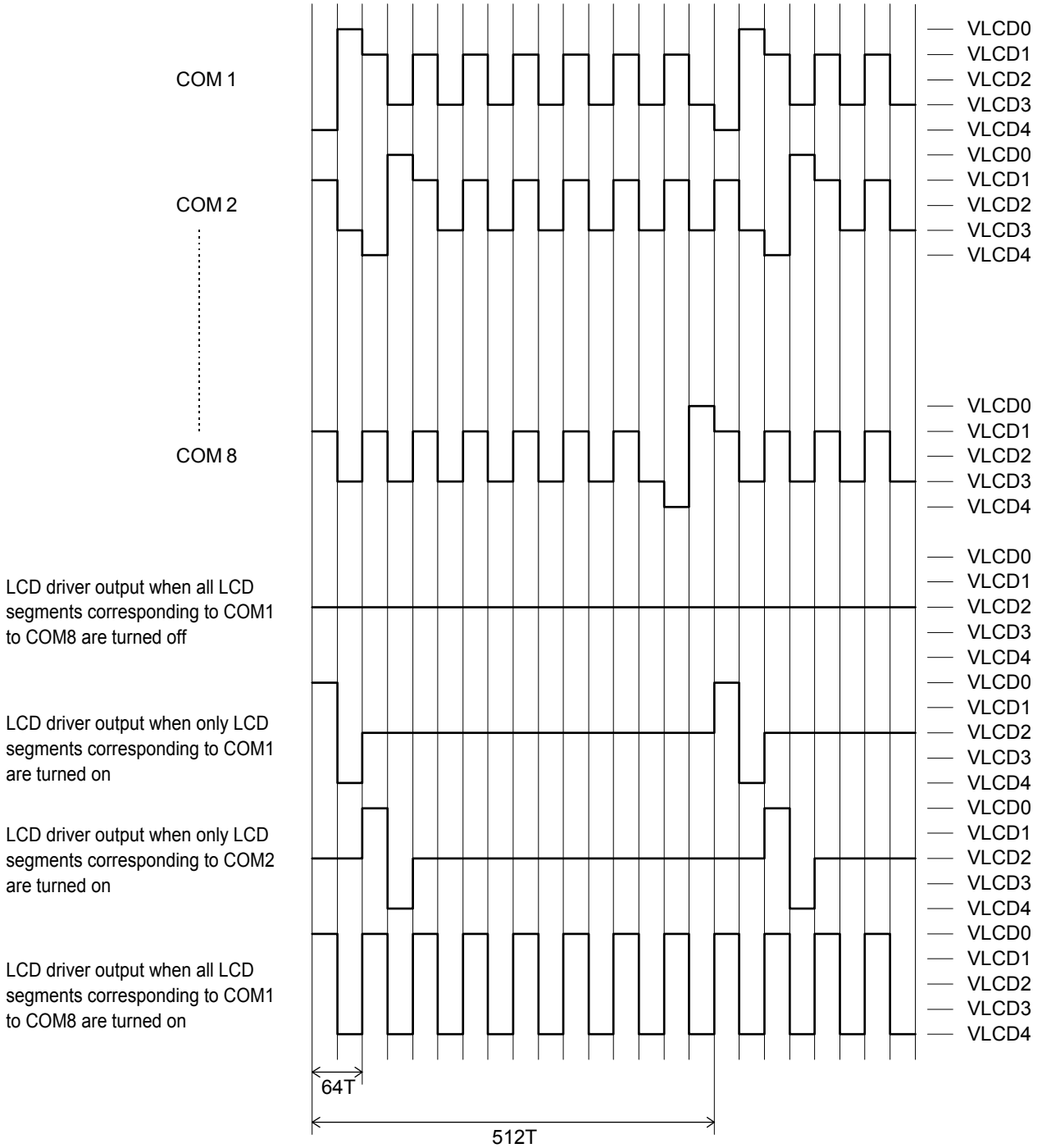

$$T = \frac{1}{f_{osc}}$$

LC75878W

1/9 Duty, 1/4 Bias Drive Technique

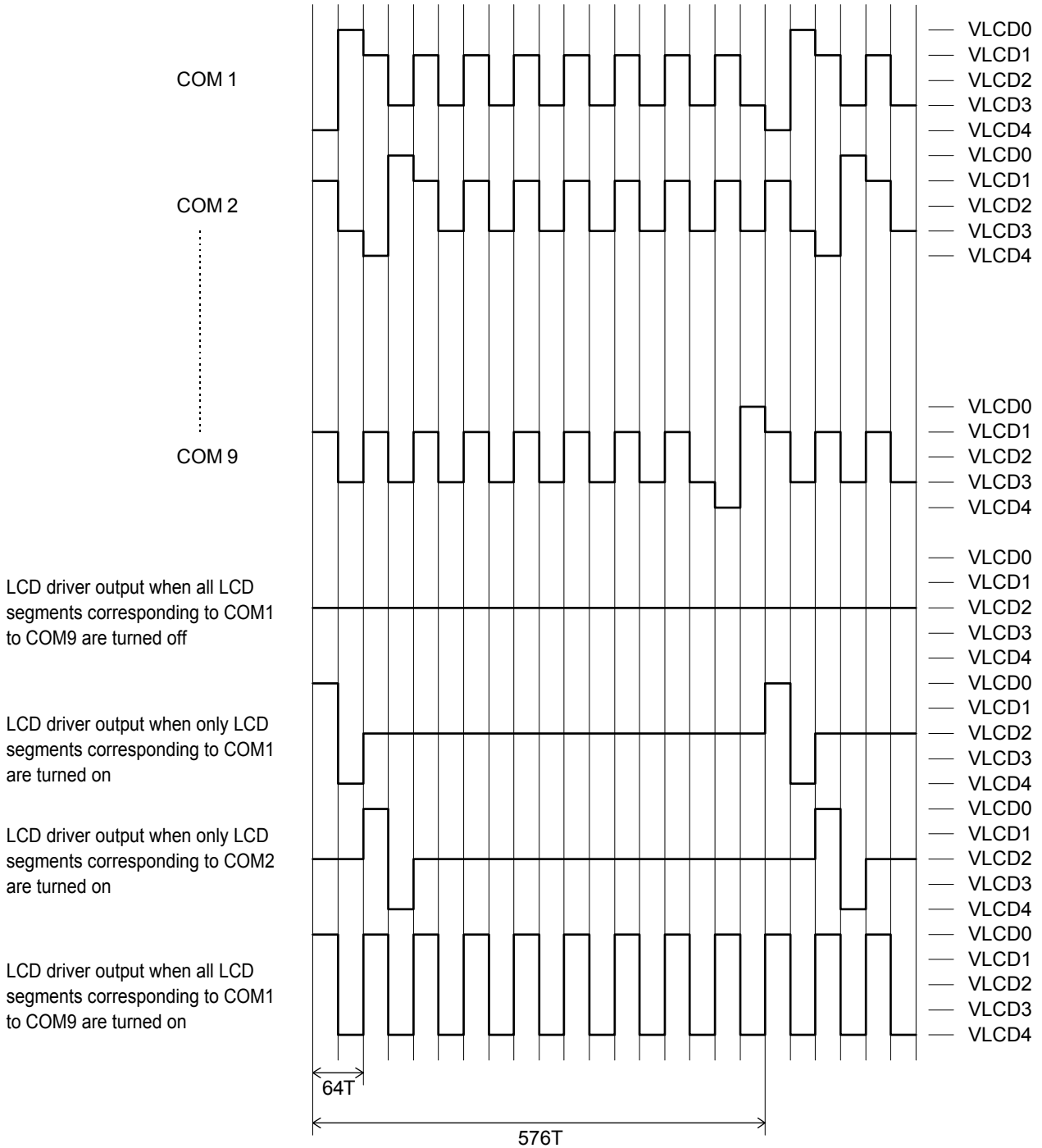

$$T = \frac{1}{f_{osc}}$$

LC75878W

1/10 Duty, 1/4 Bias Drive Technique

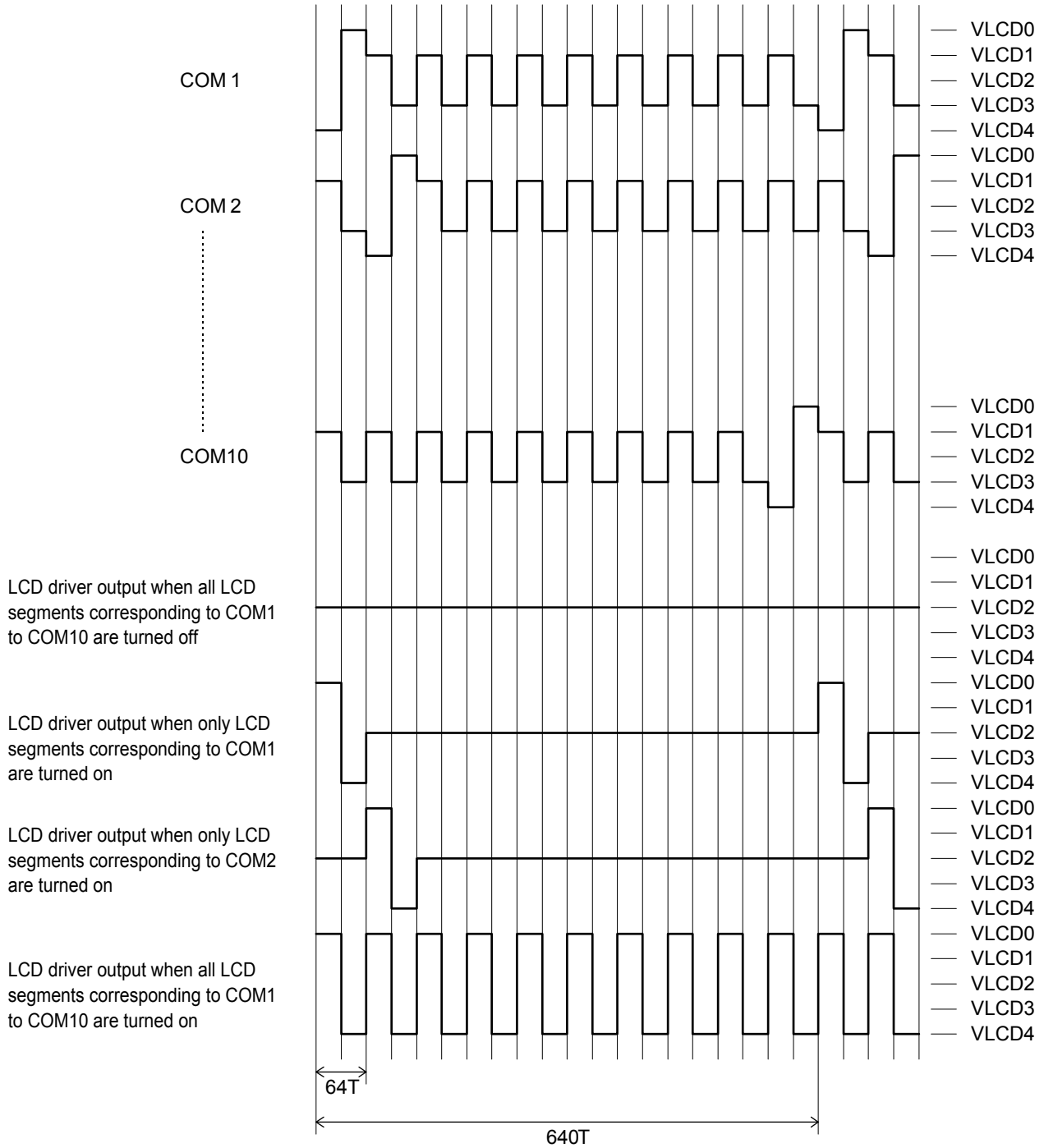

The INH Pin and Display Control

Since the IC internal data (the display data and the control data) is undefined when power is first applied, applications should set the INH pin low at the same time as power is applied to turn off the display (This sets the S1 to S73, S74/COM10, S75/COM9, and COM1 to COM8 to the V_{LCD4} level and the P1 to P4 to the V_{SS} level.) and during this period send serial data from the controller. The controller should then set the INH pin high after the data transfer has completed. This procedure prevents meaningless displays at power on. (See figures 3, 4, and 5.)

Power Supply Sequence

The following sequences must be observed when power is turned on and off. (See figures 3, 4, and 5.)

- Power on: Logic block power supply (V_{DD}) on → LCD driver block power supply (V_{LCD}) on
- Power off: LCD driver block power supply (V_{LCD}) off → Logic block power supply (V_{DD}) off

However, if the logic and LCD driver blocks use a shared power supply, then the power supplies can be turned on and off at the same time.

- 1/8 duty

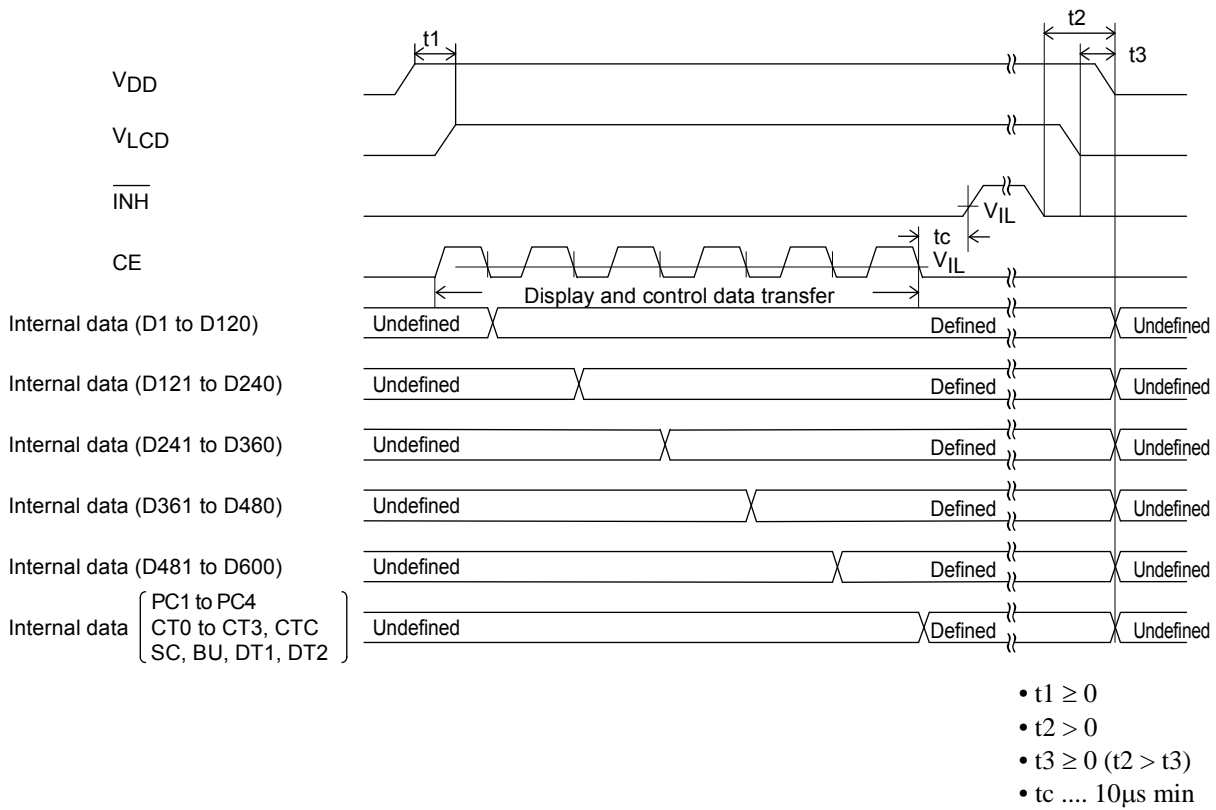

Figure 3

LC75878W

• 1/9 duty

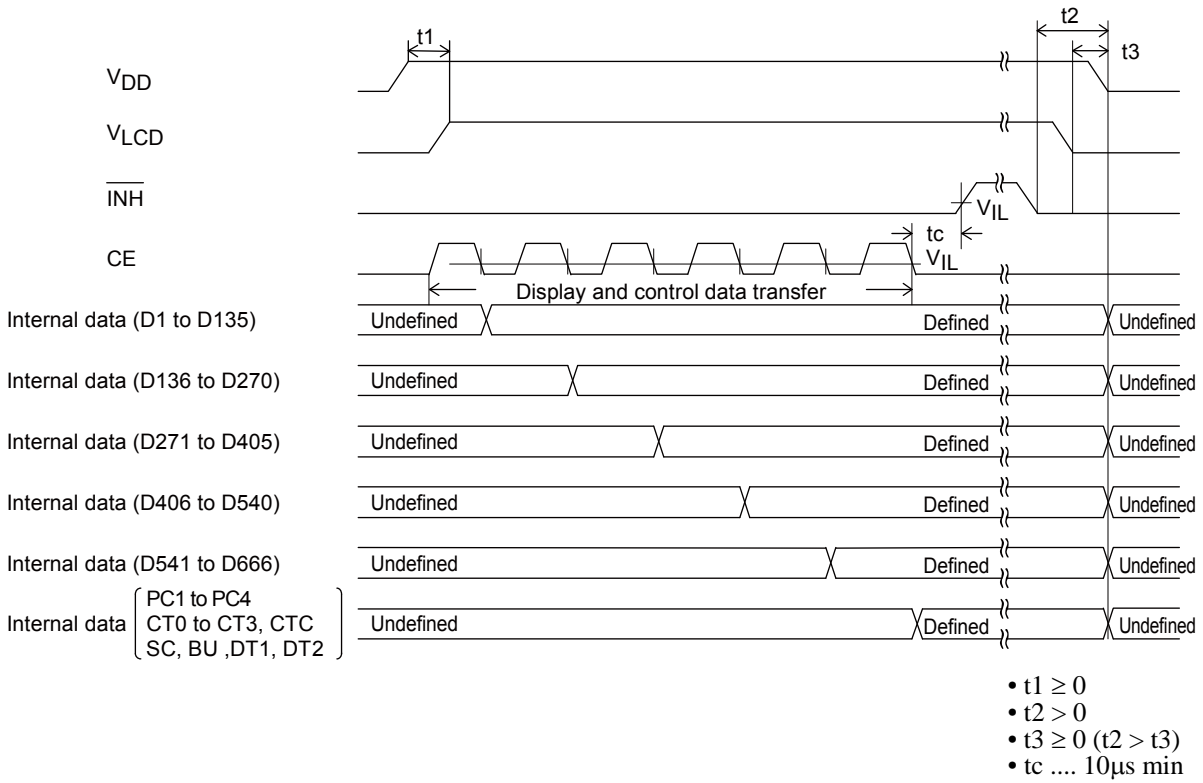

Figure 4

• 1/10 duty

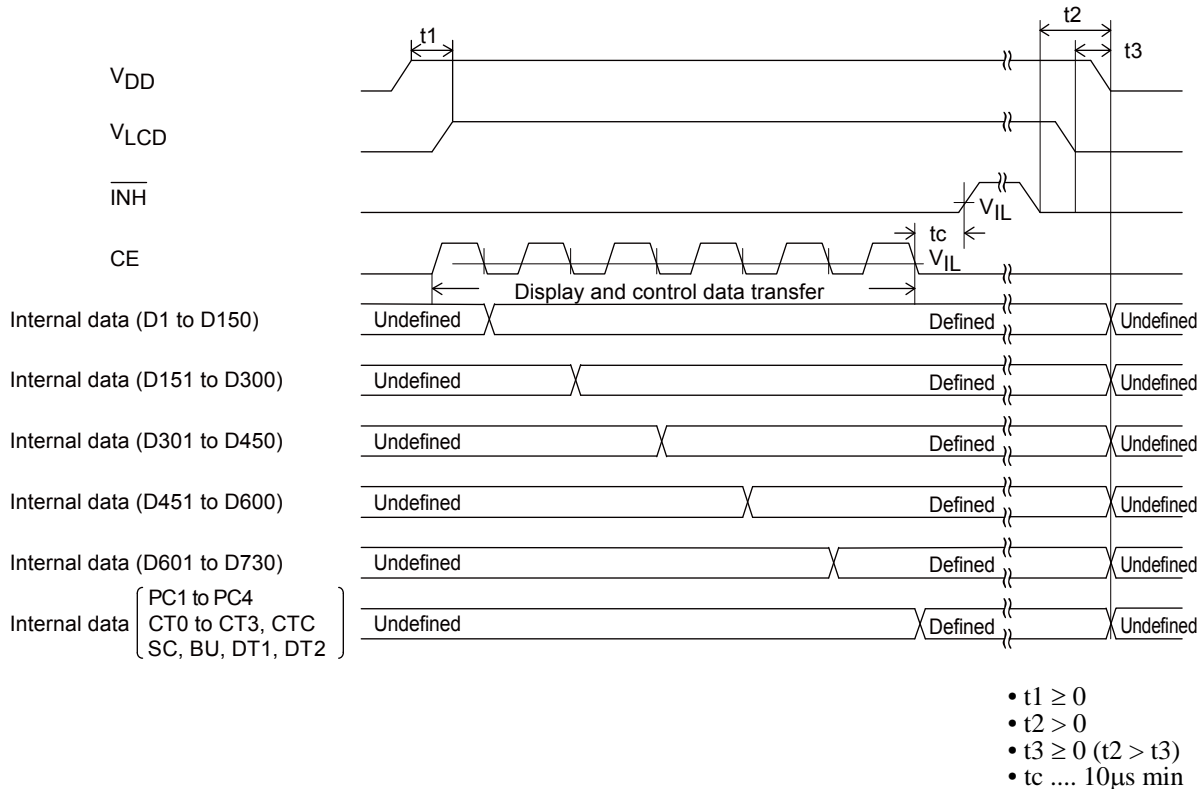

Figure 5

Notes on Transferring Display Data from the Controller

The display data is transferred to the LC75878W in five operations. All of the display data should be transferred within 30 ms to maintain the quality of the displayed image.

LC75878W

Sample Application Circuit 1

1/8 duty, 1/4 bias drive technique (for use with normal panels)

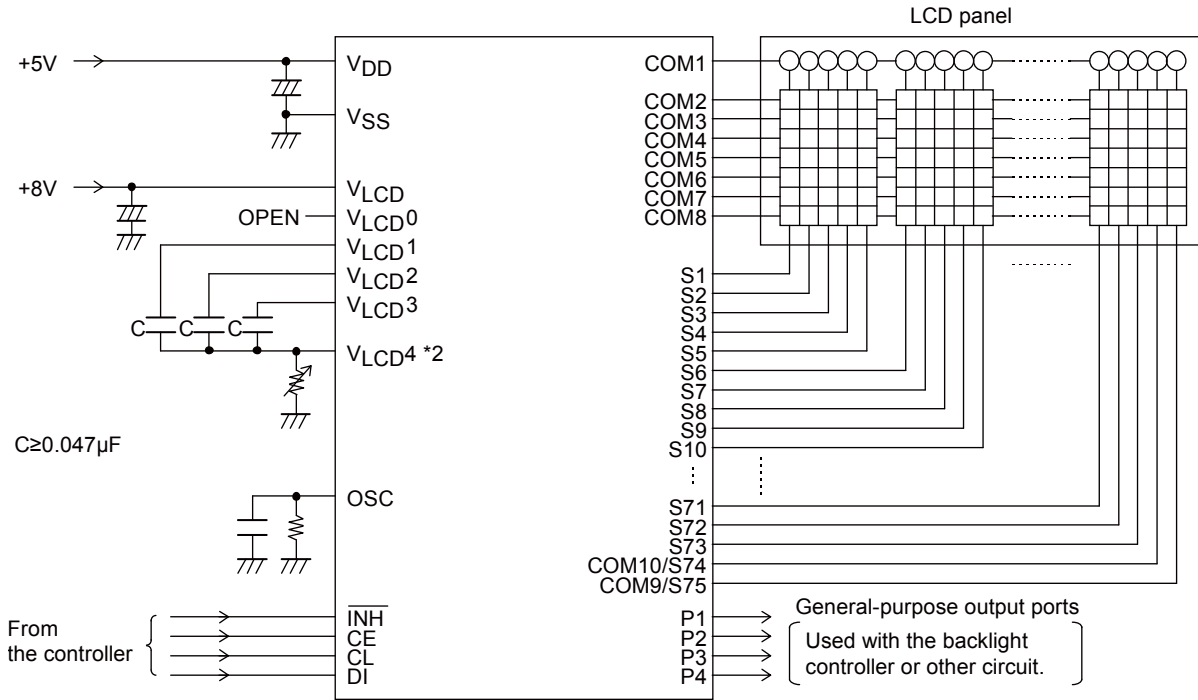

Note: *2. If a variable resistor is not used for display contrast fine adjustment, the V_{LCD4} pin must be connected to ground.

Sample Application Circuit 2

1/8 duty, 1/4 bias drive technique (for use with large panels)

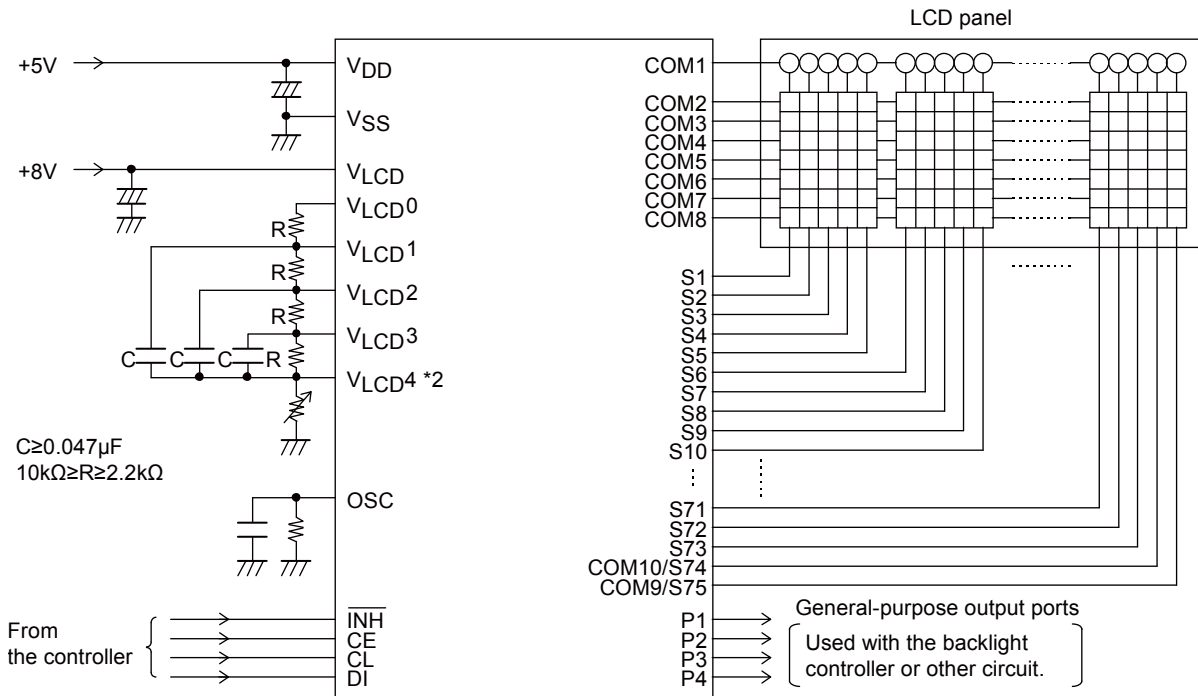

Note: *2. If a variable resistor is not used for display contrast fine adjustment, the V_{LCD4} pin must be connected to ground.

LC75878W

Sample Application Circuit 3

1/9 duty, 1/4 bias drive technique (for use with normal panels)

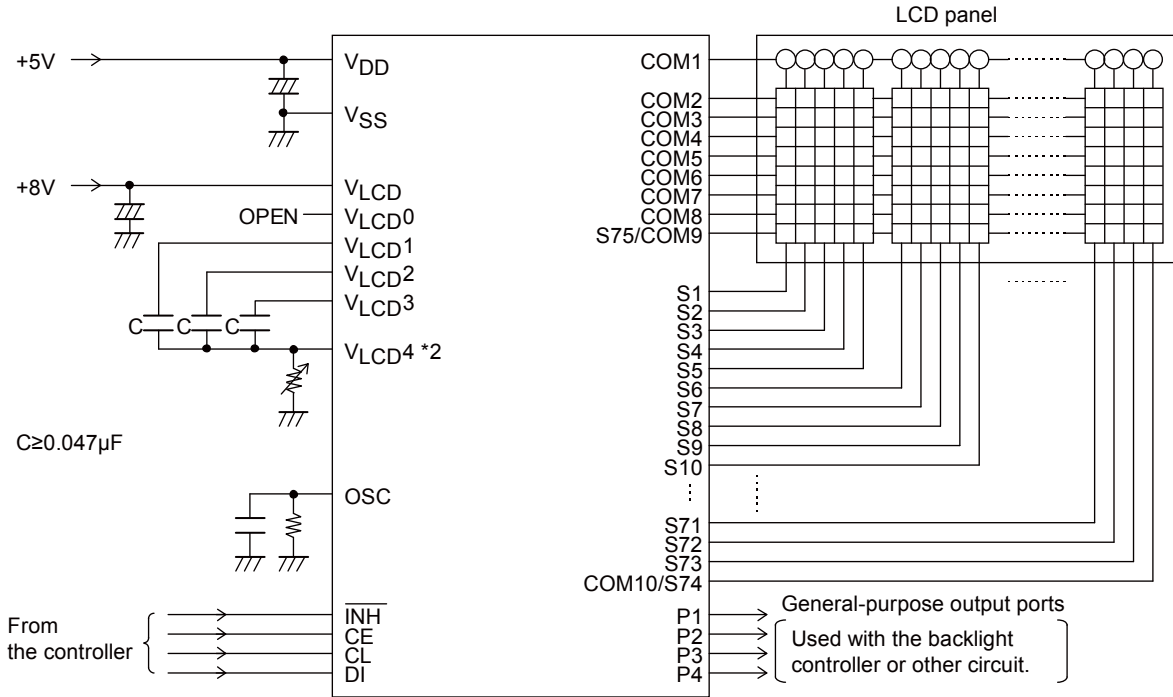

Note: *2. If a variable resistor is not used for display contrast fine adjustment, the V_{LC}D4 pin must be connected to ground.

Sample Application Circuit 4

1/9 duty, 1/4 bias drive technique (for use with large panels)

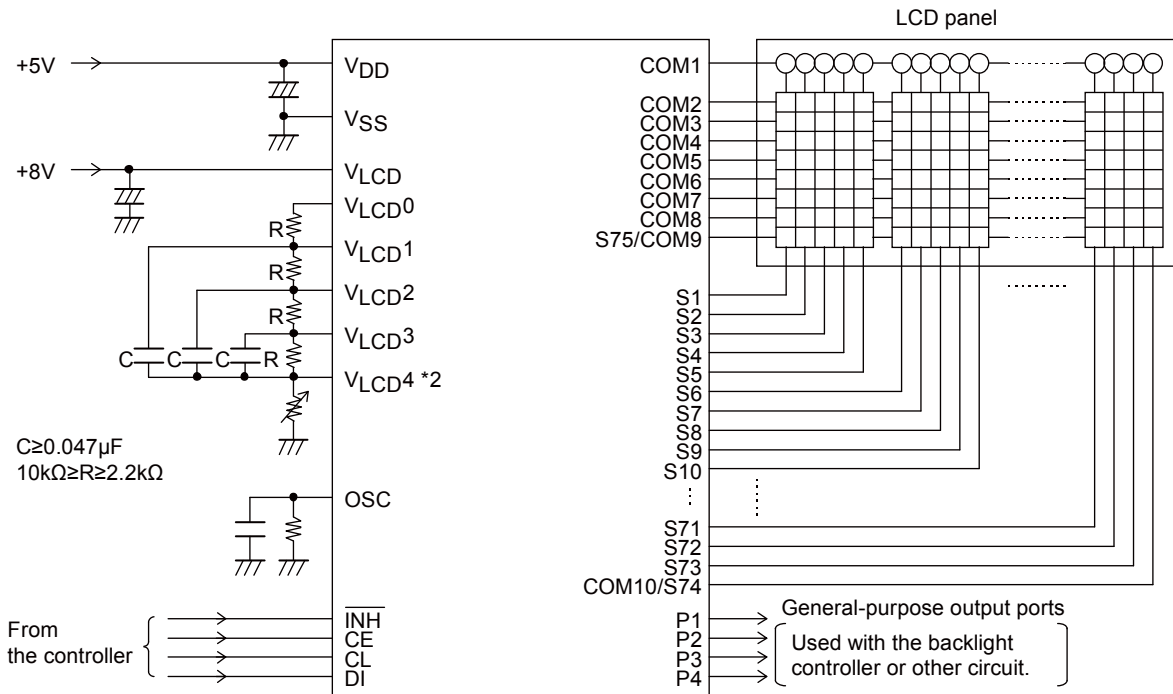

Note: *2. If a variable resistor is not used for display contrast fine adjustment, the V_{LC}D4 pin must be connected to ground.

Sample Application Circuit 5

1/10 duty, 1/4 bias drive technique (for use with normal panels)

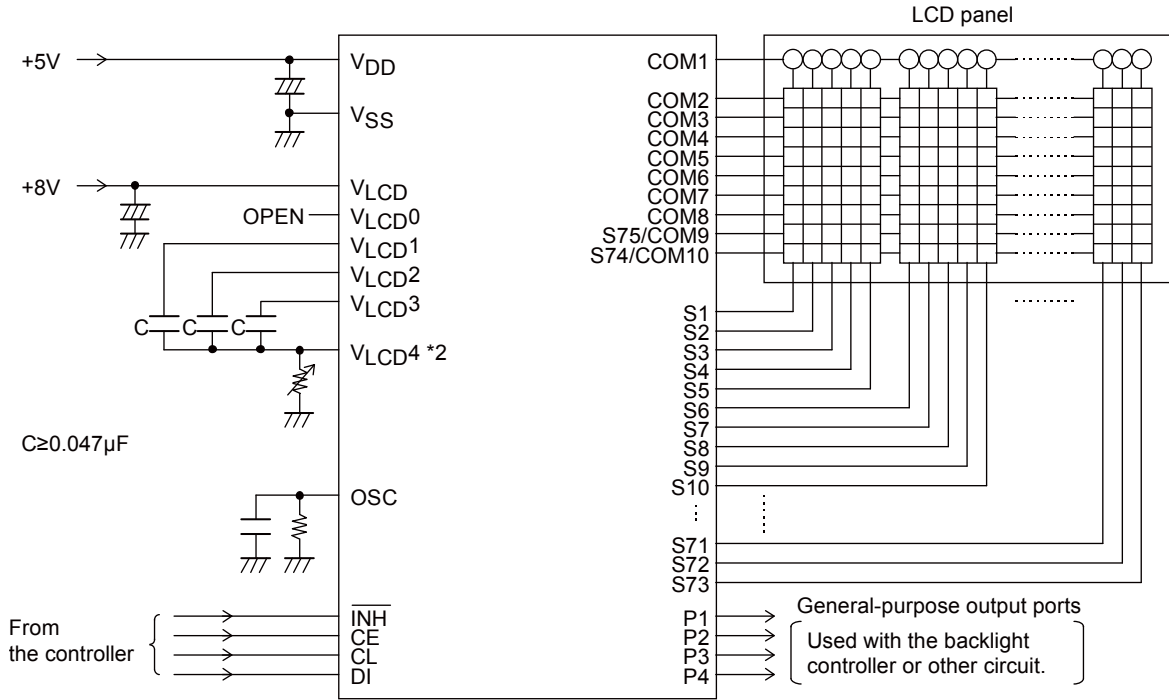

Note: *2. If a variable resistor is not used for display contrast fine adjustment, the VLCD4 pin must be connected to ground.

Sample Application Circuit 6

1/10 duty, 1/4 bias drive technique (for use with large panels)

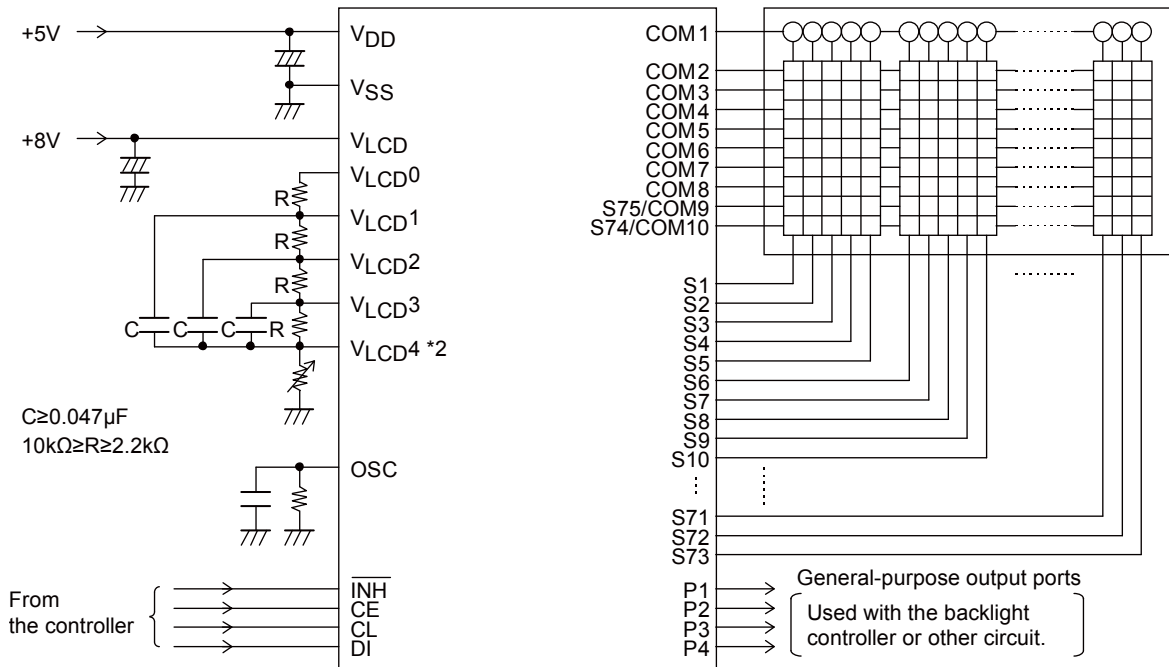

Note: *2. If a variable resistor is not used for display contrast fine adjustment, the VLCD4 pin must be connected to ground.

LC75878W

Package Dimensions

unit : mm

SPQFP100 14x14 / SQFP100

CASE 131AC

ISSUE A

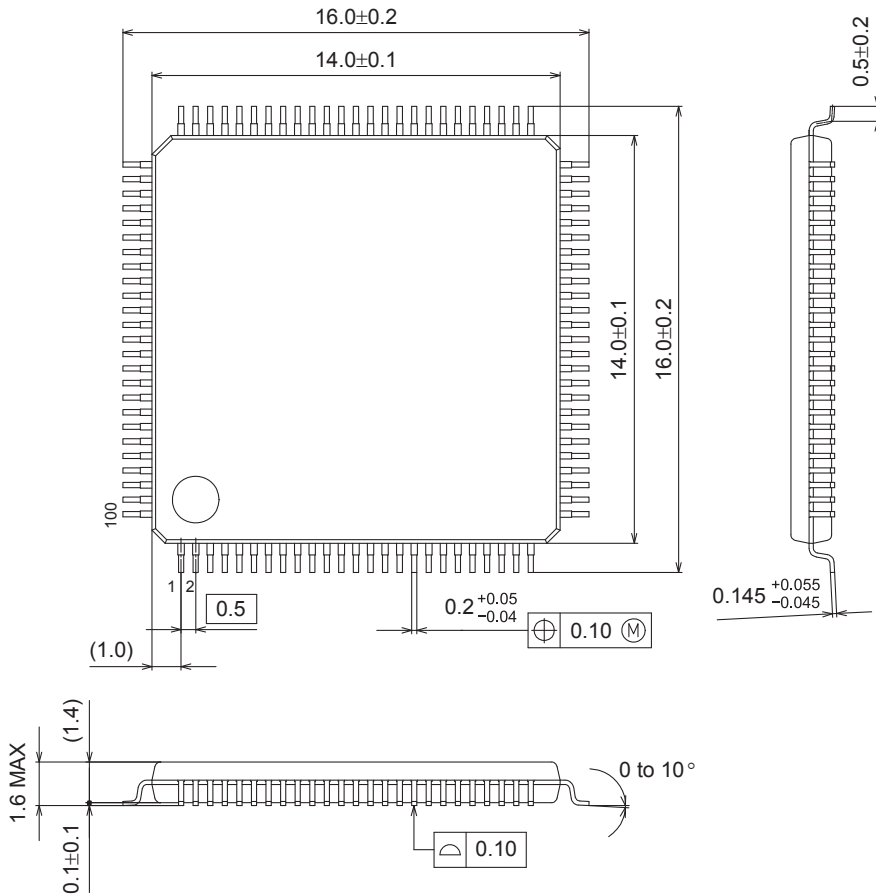

SOLDERING FOOTPRINT*

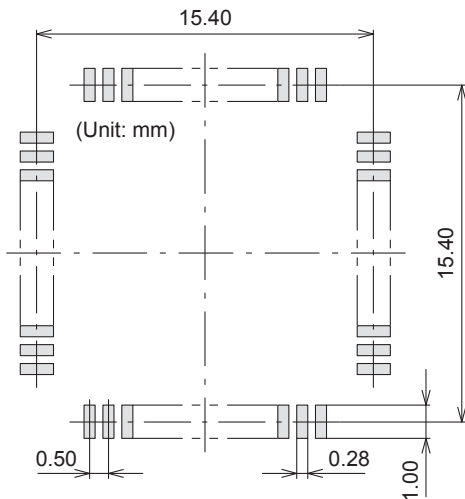

GENERIC MARKING DIAGRAM*

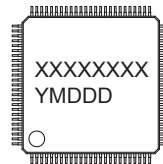

XXXXX = Specific Device Code
 Y = Year
 M = Month
 DDD = Additional Traceability Data

*This information is generic. Please refer to device data sheet for actual part marking. Pb-Free indicator, "G" or microdot "▪", may or may not be present.

NOTE: The measurements are not to guarantee but for reference only.

*For additional information on our Pb-Free strategy and soldering details, please download the ON Semiconductor Soldering and Mounting Techniques Reference Manual, SOLDERRM/D.

LC75878W



ORDERING INFORMATION

Device	Package	Shipping (Qty / Packing)
LC75878W-E	SPQFP100 14x14 / SQFP100 (Pb-Free)	300 / Tray Foam
LC75878WS-E	SPQFP100 14x14 / SQFP100 (Pb-Free)	300 / Tray Foam





ON Semiconductor and the ON Semiconductor logo are trademarks of Semiconductor Components Industries, LLC dba ON Semiconductor or its subsidiaries in the United States and/or other countries. ON Semiconductor owns the rights to a number of patents, trademarks, copyrights, trade secrets, and other intellectual property. A listing of ON Semiconductor's product/patent coverage may be accessed at www.onsemi.com/site/pdf/Patent-Marking.pdf. ON Semiconductor reserves the right to make changes without further notice to any products herein. ON Semiconductor makes no warranty, representation or guarantee regarding the suitability of its products for any particular purpose, nor does ON Semiconductor assume any liability arising out of the application or use of any product or circuit, and specifically disclaims any and all liability, including without limitation special, consequential or incidental damages. Buyer is responsible for its products and applications using ON Semiconductor products, including compliance with all laws, regulations and safety requirements or standards, regardless of any support or applications information provided by ON Semiconductor. "Typical" parameters which may be provided in ON Semiconductor data sheets and/or specifications can and do vary in different applications and actual performance may vary over time. All operating parameters, including "Typicals" must be validated for each customer application by customer's technical experts. ON Semiconductor does not convey any license under its patent rights nor the rights of others. ON Semiconductor products are not designed, intended, or authorized for use as a critical component in life support systems or any FDA Class 3 medical devices or medical devices with a same or similar classification in a foreign jurisdiction or any devices intended for implantation in the human body. Should Buyer purchase or use ON Semiconductor products for any such unintended or unauthorized application, Buyer shall indemnify and hold ON Semiconductor and its officers, employees, subsidiaries, affiliates, and distributors harmless against all claims, costs, damages, and expenses, and reasonable attorney fees arising out of, directly or indirectly, any claim of personal injury or death associated with such unintended or unauthorized use, even if such claim alleges that ON Semiconductor was negligent regarding the design or manufacture of the part. ON Semiconductor is an Equal Opportunity/Affirmative Action Employer. This literature is subject to all applicable copyright laws and is not for resale in any manner.

Looking for pricing, stock, or lifecycle information?

Click below to explore more details on WIN SOURCE:

-  [View LC75878W-E on WIN SOURCE](#)
-  [ON Semiconductor](#) Information

Optimize Your Supply Chain with WIN SOURCE Solutions

-  Global Sourcing Solution
-  Obsolete Management
-  Cost Control Management
-  Shortage Management
-  Alternative Solution
-  Excess Inventory Management