



**THE DATASHEET OF  
AT27BV1024-90JU**



## Features

- Fast read access time – 90ns
- Dual voltage range operation
  - Unregulated battery power supply range, 2.7V to 3.6V, or
  - Standard power supply range, 5V  $\pm$  10%
- Pin compatible with JEDEC standard Atmel® AT27C1024
- Low-power CMOS operation
  - 20 $\mu$ A max standby (less than 1 $\mu$ A, typical) for  $V_{CC} = 3.6V$
  - 36mW max active at 5MHz for  $V_{CC} = 3.6V$
- JEDEC standard surface mount package
  - 44-lead PLCC
- High-reliability CMOS technology
  - 2,000V ESD protection
  - 200mA latchup immunity
- Rapid programming algorithm – 100 $\mu$ s/word (typical)
- CMOS- and TTL-compatible inputs and outputs
  - JEDEC standard for LVTTTL and LVBO
- Integrated product identification code
- Industrial temperature range

### 1. Description

The Atmel AT27BV1024 is a high-performance, low-power, low-voltage, 1,048,576-bit, one-time programmable, read-only memory (OTP EPROM) organized as 64K by 16 bits. It requires only one supply in the range of 2.7V to 3.6V in normal read mode operation. The x16 organization makes this part ideal for portable and handheld 16- and 32-bit microprocessor-based systems using either regulated or unregulated battery power.

The Atmel innovative design techniques provide fast speeds that rival 5V parts, while keeping the low power consumption of a 3V supply. At  $V_{CC} = 2.7V$ , any word can be accessed in less than 90ns. With a typical power dissipation of only 18mW at 5MHz and  $V_{CC} = 3V$ , the AT27BV1024 consumes less than one-fifth the power of a standard, 5V EPROM.

Standby mode supply current is typically less than 1 $\mu$ A at 3V. The AT27BV1024 simplifies system design and stretches battery lifetime even further by eliminating the need for power supply regulation.

The AT27BV1024 is available in an industry-standard, JEDEC-approved, one-time programmable (OTP) PLCC package. All devices feature two-line control ( $\overline{CE}$ ,  $\overline{OE}$ ) to give designers the flexibility to prevent bus contention.

The AT27BV1024 operating with  $V_{CC}$  at 3.0V produces TTL-level outputs that are compatible with standard TTL logic devices operating at  $V_{CC} = 5.0V$ . At  $V_{CC} = 2.7V$ , the part is compatible with JEDEC-approved, low-voltage battery operation (LVBO) interface specifications. The device is also capable of standard, 5V operation making it ideally suited for dual supply range systems or card products that are pluggable in both 3V and 5V hosts.

The AT27BV1024 has additional features to ensure high quality and efficient production use. The rapid programming algorithm reduces the time required to program the part and guarantees reliable programming. Programming time is typically only 100  $\mu$ s/word. The integrated product identification code electronically identifies the device and



1Mb (64K x 16)  
Unregulated  
Battery Voltage,  
High-speed,  
One-time  
Programmable,  
Read-only Memory

Atmel AT27BV1024



manufacturer. This feature is used by industry-standard programming equipment to select the proper programming algorithms and voltages. The AT27BV1024 programs in exactly the same way as a standard, 5V Atmel AT27C1024, and uses the same programming equipment.

## 2. Pin configurations

Pin Name	Function
A0 - A15	Addresses
O0 - O15	Outputs
$\overline{CE}$	Chip enable
$\overline{OE}$	Output enable
$\overline{PGM}$	Program strobe
NC	No connect

Note: Both GND pins must be connected.

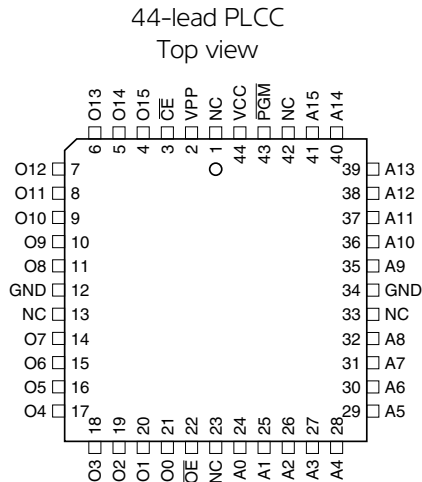

Note: PLCC Package Pins 1 and 23 are "don't connect."

## 3. System considerations

Switching between active and standby conditions via the chip enable pin may produce transient voltage excursions. Unless accommodated by the system design, these transients may exceed datasheet limits, resulting in device non-conformance. At a minimum, a 0.1 $\mu$ F, high-frequency, low inherent inductance, ceramic capacitor should be utilized for each device. This capacitor should be connected between the  $V_{CC}$  and ground terminals of the device, as close to the device as possible. Additionally, to stabilize the supply voltage level on printed circuit boards with large EPROM arrays, a 4.7 $\mu$ F bulk electrolytic capacitor should be utilized, again connected between the  $V_{CC}$  and ground terminals. This capacitor should be positioned as close as possible to the point where the power supply is connected to the array.

Figure 3-1. Block diagram

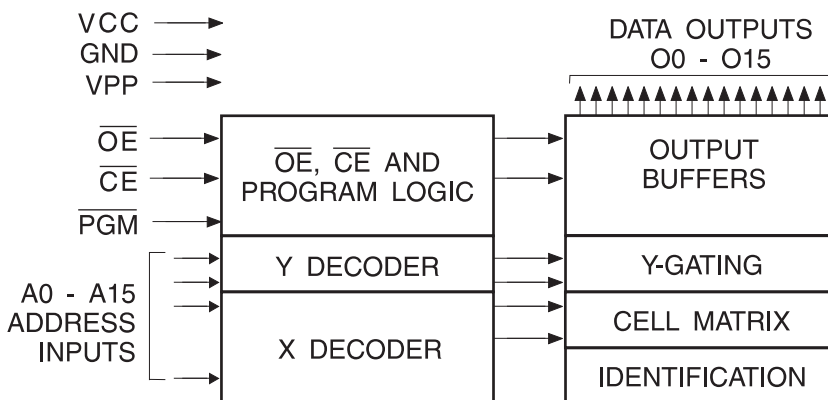

#### 4. Absolute maximum ratings\*

Temperature under bias . . . . .	-55°C to +125°C
Storage temperature . . . . .	-65°C to +150°C
Voltage on any pin with respect to ground . . . . .	-2.0V to +7.0V <sup>(1)</sup>
Voltage on A9 with respect to ground . . . . .	-2.0V to +14.0V <sup>(1)</sup>
V <sub>pp</sub> supply voltage with respect to ground . . . . .	-2.0V to +14.0V <sup>(1)</sup>

\*NOTICE: Stresses beyond those listed under “Absolute maximum ratings” may cause permanent damage to the device. This is a stress rating only, and functional operation of the device at these or any other conditions beyond those indicated in the operational sections of this specification is not implied. Exposure to absolute maximum rating conditions for extended periods may affect device reliability.

Note: 1. Minimum voltage is -0.6V DC, which may undershoot to -2.0V for pulses of less than 20ns. Maximum output pin voltage is V<sub>CC</sub> + 0.75V DC, which may overshoot to +7.0V for pulses of less than 20ns.

#### 5. AC and DC characteristics

Table 5-1. Operating modes

Mode/Pin	$\overline{CE}$	$\overline{OE}$	$\overline{PGM}$	Ai	V <sub>PP</sub>	V <sub>CC</sub>	Outputs
Read <sup>(2)</sup>	V <sub>IL</sub>	V <sub>IL</sub>	X <sup>(1)</sup>	Ai	X	V <sub>CC</sub>	D <sub>OUT</sub>
Output disable <sup>(2)</sup>	X	V <sub>IH</sub>	X	X	X	V <sub>CC</sub>	High Z
Standby <sup>(2)</sup>	V <sub>IH</sub>	X	X	X	X <sup>(5)</sup>	V <sub>CC</sub>	High Z
Rapid program <sup>(3)</sup>	V <sub>IL</sub>	V <sub>IH</sub>	V <sub>IL</sub>	Ai	V <sub>PP</sub>	V <sub>CC</sub>	D <sub>IN</sub>
PGM verify <sup>(3)</sup>	V <sub>IL</sub>	V <sub>IL</sub>	V <sub>IH</sub>	Ai	V <sub>PP</sub>	V <sub>CC</sub>	D <sub>OUT</sub>
PGM inhibit <sup>(3)</sup>	V <sub>IH</sub>	X	X	X	V <sub>PP</sub>	V <sub>CC</sub>	High Z
Product identification <sup>(3)(5)</sup>	V <sub>IL</sub>	V <sub>IL</sub>	X	A9 = V <sub>H</sub> <sup>(4)</sup> A0 = V <sub>IH</sub> or V <sub>IL</sub> A1 - A15 = V <sub>IL</sub>	V <sub>CC</sub>	V <sub>CC</sub>	Identification code

- Notes:
1. X can be V<sub>IL</sub> or V<sub>IH</sub>.
  2. Read, output disable, and standby modes require 2.7V ≤ V<sub>CC</sub> ≤ 3.6V or 4.5V ≤ V<sub>CC</sub> ≤ 5.5V.
  3. Refer to programming characteristics. Programming modes require V<sub>CC</sub> = 6.5V.
  4. V<sub>H</sub> = 12.0 ± 0.5V.
  5. Two identifier words may be selected. All Ai inputs are held low (V<sub>IL</sub>) except A9, which is set to V<sub>H</sub>, and A0, which is toggled low (V<sub>IL</sub>) to select the manufacturer’s identification word and high (V<sub>IH</sub>) to select the device code word.

Table 5-2. DC and AC operating conditions for read operation

	Atmel AT27BV1024-90
Industrial operating temperature (case)	-40°C - 85°C
V <sub>CC</sub> power supply	2.7V to 3.6V
	5V ± 10%

Table 5-3. DC and operating characteristics for read operation

Symbol	Parameter	Condition	Min	Max	Units
<b><math>V_{CC} = 2.7V</math> to <math>3.6V</math></b>					
$I_{LI}$	Input load current	$V_{IN} = 0V$ to $V_{CC}$		$\pm 1$	$\mu A$
$I_{LO}$	Output leakage current	$V_{OUT} = 0V$ to $V_{CC}$		$\pm 5$	$\mu A$
$I_{PP1}^{(2)}$	$V_{PP}^{(1)}$ read/standby current	$V_{PP} = V_{CC}$		10	$\mu A$
$I_{SB}$	$V_{CC}^{(1)}$ standby current	$I_{SB1}$ (CMOS), $\overline{CE} = V_{CC} \pm 0.3V$		20	$\mu A$
		$I_{SB2}$ (TTL), $\overline{CE} = 2.0$ to $V_{CC} + 0.5V$		100	$\mu A$
$I_{CC}$	$V_{CC}$ active current	$f = 5MHz$ , $I_{OUT} = 0mA$ , $\overline{CE} = V_{IL}$ , $V_{CC} = 3.6V$		8	mA
$V_{IL}$	Input low voltage	$V_{CC} = 3.0$ to $3.6V$	-0.6	0.8	V
		$V_{CC} = 2.7$ to $3.6V$	-0.6	$0.2 \times V_{CC}$	V
$V_{IH}$	Input high voltage	$V_{CC} = 3.0$ to $3.6V$	2.0	$V_{CC} + 0.5$	V
		$V_{CC} = 2.7$ to $3.6V$	$0.7 \times V_{CC}$	$V_{CC} + 0.5$	V
$V_{OL}$	Output low voltage	$I_{OL} = 2.0mA$		0.4	V
		$I_{OL} = 100\mu A$		0.2	V
		$I_{OL} = 20\mu A$		0.1	V
$V_{OH}$	Output high voltage	$I_{OH} = -2.0mA$	2.4		V
		$I_{OH} = -100\mu A$	$V_{CC} - 0.2$		V
		$I_{OH} = -20\mu A$	$V_{CC} - 0.1$		V
<b><math>V_{CC} = 4.5V</math> to <math>5.5V</math></b>					
$I_{LI}$	Input load current	$V_{IN} = 0V$ to $V_{CC}$		$\pm 1$	$\mu A$
$I_{LO}$	Output leakage current	$V_{OUT} = 0V$ to $V_{CC}$		$\pm 5$	$\mu A$
$I_{PP1}^{(2)}$	$V_{PP}^{(1)}$ read/standby current	$V_{PP} = V_{CC}$		10	$\mu A$
$I_{SB}$	$V_{CC}^{(1)}$ standby current	$I_{SB1}$ (CMOS), $\overline{CE} = V_{CC} \pm 0.3V$		100	$\mu A$
		$I_{SB2}$ (TTL), $\overline{CE} = 2.0$ to $V_{CC} + 0.5V$		1	mA
$I_{CC}$	$V_{CC}$ active current	$f = 5MHz$ , $I_{OUT} = 0mA$ , $\overline{CE} = V_{IL}$		30	mA
$V_{IL}$	Input low voltage		-0.6	0.8	V
$V_{IH}$	Input high voltage		2.0	$V_{CC} + 0.5$	V
$V_{OL}$	Output low voltage	$I_{OL} = 2.1mA$		0.4	V
$V_{OH}$	Output high voltage	$I_{OH} = -400\mu A$	2.4		V

- Notes:
- $V_{CC}$  must be applied simultaneously with or before  $V_{pp}$ , and removed simultaneously with or after  $V_{pp}$ .
  - $V_{pp}$  may be connected directly to  $V_{CC}$ , except during programming. The supply current would then be the sum of  $I_{CC}$  and  $I_{pp}$ .

Table 5-4. AC characteristics for read operation

Symbol	Parameter	Condition	Atmel AT27BV1024-90		Unit
			Min	Max	
$t_{ACC}^{(3)}$	Address to output delay	$\overline{CE} = \overline{OE} = V_{IL}$		90	ns
$t_{CE}^{(2)}$	$\overline{CE}$ to output delay	$\overline{OE} = V_{IL}$		90	ns
$t_{OE}^{(2)(3)}$	$\overline{OE}$ to output delay	$\overline{CE} = V_{IL}$		30	ns
$t_{DF}^{(4)(5)}$	$\overline{OE}$ or $\overline{CE}$ High to output float, whichever occurred first			30	ns
$t_{OH}$	Output hold from address, $\overline{CE}$ or $\overline{OE}$ , whichever occurred first		0		ns

Figure 5-1. AC waveforms for read operation<sup>(1)</sup>

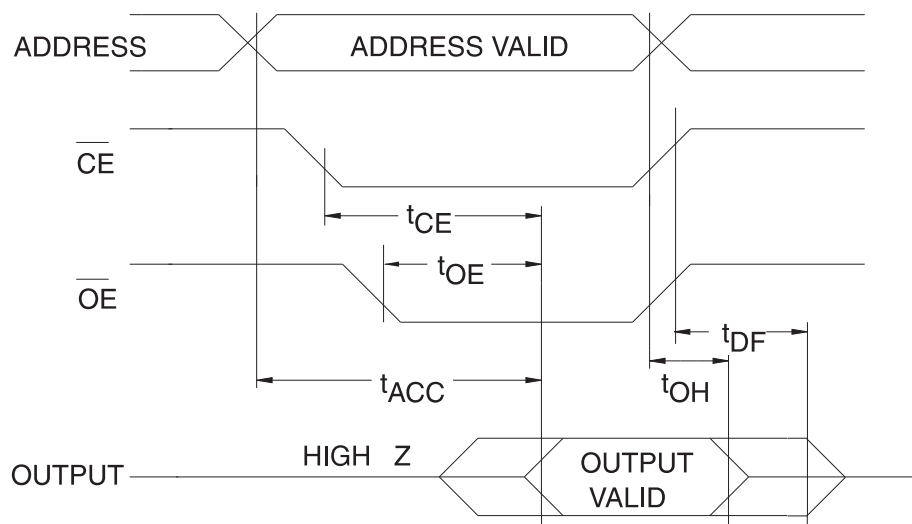

- Note:
1. Timing measurement references are 0.8V and 2.0V. Input AC drive levels are 0.45V and 2.4V, unless otherwise specified.
  2.  $\overline{OE}$  may be delayed up to  $t_{CE} - t_{OE}$  after the falling edge of  $\overline{CE}$  without impact on  $t_{CE}$ .
  3.  $\overline{OE}$  may be delayed up to  $t_{ACC} - t_{OE}$  after the address is valid without impact on  $t_{ACC}$ .
  4. This parameter is only sampled, and is not 100% tested.
  5. Output float is defined as the point when data is no longer driven.
  6. When reading an Atmel AT27BV1024, a 0.1 $\mu$ F capacitor is required across  $V_{CC}$  and ground to suppress spurious voltage transients.

Figure 5-2. Input test waveforms and measurement levels

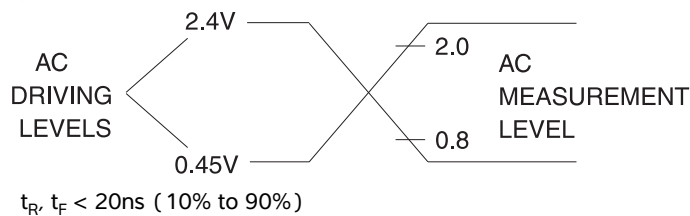
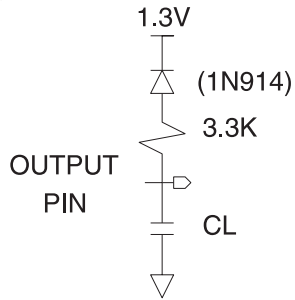

Figure 5-3. Output test load



Note: CL = 100pF including jig capacitance.

Table 5-5. Pin capacitance

f = 1MHz T = 25°C <sup>(1)</sup>

Symbol	Typ	Max	Units	Conditions
C <sub>IN</sub>	4	10	pF	V <sub>IN</sub> = 0V
C <sub>OUT</sub>	8	12	pF	V <sub>OUT</sub> = 0V

Note: 1. Typical values for nominal supply voltage. This parameter is only sampled, and is not 100% tested.

Figure 5-4. Programming waveforms <sup>(1)</sup>

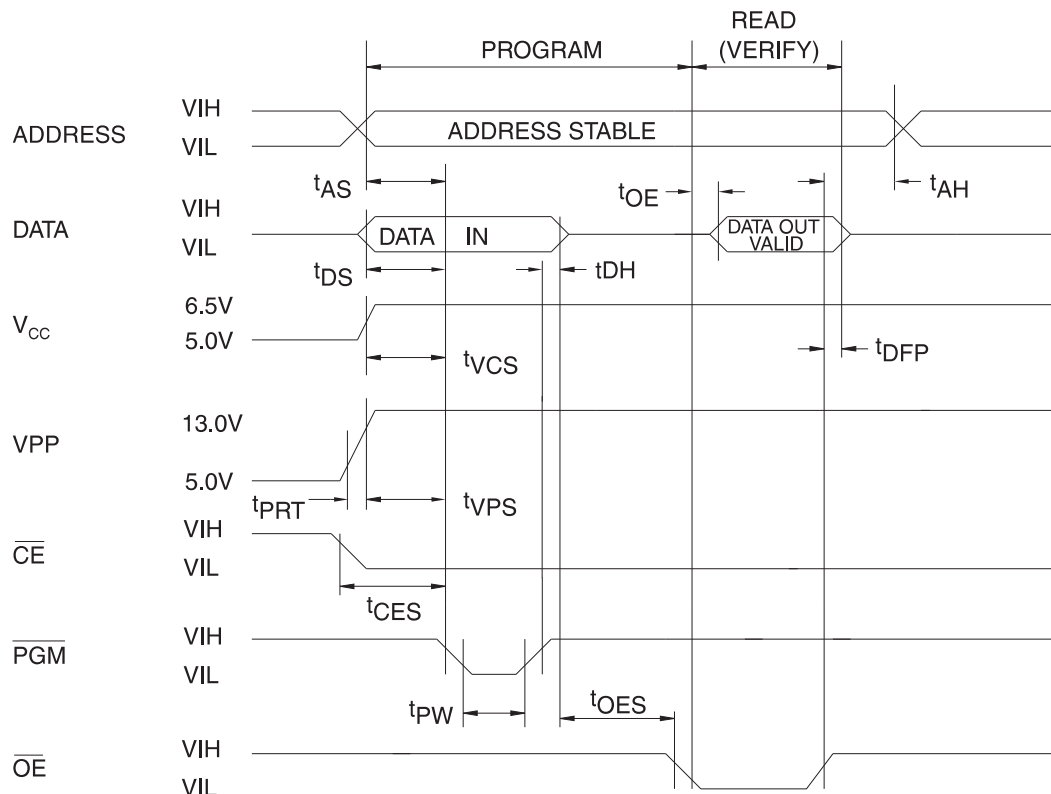

- Note:
1. The input timing reference is 0.8V for V<sub>IL</sub> and 2.0V for V<sub>IH</sub>.
  2. t<sub>OE</sub> and t<sub>DFP</sub> are characteristics of the device, but must be accommodated by the programmer.
  3. When programming the Atmel AT27BV1024 a 0.1μF capacitor is required across V<sub>pp</sub> and ground to suppress spurious voltage transients.

Table 5-6. DC programming characteristics

 $T_A = 25 \pm 5^\circ \text{C}$ ,  $V_{CC} = 6.5 \pm 0.25\text{V}$ ,  $V_{PP} = 13.0 \pm 0.25\text{V}$ 

Symbol	Parameter	Test conditions	Limits		Units
			Min	Max	
$I_{LI}$	Input load current	$V_{IN} = V_{IL}, V_{IH}$		$\pm 10$	$\mu\text{A}$
$V_{IL}$	Input low level		-0.6	0.8	V
$V_{IH}$	Input high level		2.0	$V_{CC} + 0.1$	V
$V_{OL}$	Output low voltage	$I_{OL} = 2.1\text{mA}$		0.4	V
$V_{OH}$	Output high voltage	$I_{OH} = -400\mu\text{A}$	2.4		V
$I_{CC2}$	$V_{CC}$ supply current (program and verify)			50	mA
$I_{PP2}$	$V_{PP}$ supply current	$\overline{CE} = \overline{PGM} = V_{IL}$		30	mA
$V_{ID}$	A9 product identification voltage		11.5	12.5	V

Table 5-7. AC programming characteristics

 $T_A = 25 \pm 5^\circ \text{C}$ ,  $V_{CC} = 6.5 \pm 0.25\text{V}$ ,  $V_{PP} = 13.0 \pm 0.25\text{V}$ 

Symbol	Parameter	Test conditions <sup>(1)</sup>	Limits		Units
			Min	Max	
$t_{AS}$	Address setup time	Input rise and fall times: (10% to 90%) 20ns	2		$\mu\text{s}$
$t_{CES}$	$\overline{CE}$ setup time		2		$\mu\text{s}$
$t_{OES}$	$\overline{OE}$ setup time		2		$\mu\text{s}$
$t_{DS}$	Data setup time		2		$\mu\text{s}$
$t_{AH}$	Address hold time	Input pulse levels: 0.45V to 2.4V	0		$\mu\text{s}$
$t_{DH}$	Data hold time		2		$\mu\text{s}$
$t_{DFP}$	$\overline{OE}$ high to output float delay <sup>(2)</sup>	Input timing reference level: 0.8V to 2.0V	0	130	ns
$t_{VPS}$	$V_{PP}$ setup time		2		$\mu\text{s}$
$t_{VCS}$	$V_{CC}$ setup time		2		$\mu\text{s}$
$t_{PW}$	$\overline{PGM}$ program pulse width <sup>(3)</sup>		Output timing reference level: 0.8V to 2.0V	95	105
$t_{OE}$	Data valid from $\overline{OE}$			150	ns
$t_{PRT}$	$V_{PP}$ pulse rise time during programming	50			ns

Notes: 1.  $V_{CC}$  must be applied simultaneously with or before  $V_{PP}$  and removed simultaneously with or after  $V_{PP}$ .

2. This parameter is only sampled, and is not 100% tested. Output float is defined as the point where data is no longer driven. See timing diagram.

3. Program pulse width tolerance is  $100\mu\text{sec} \pm 5\%$ .

Table 5-8. The Atmel AT27BV1024 integrated product identification code<sup>(1)</sup>

Codes	Pins										Hex data
	A0	O15-O8	O7	O6	O5	O4	O3	O2	O1	O0	
Manufacturer	0	0	0	0	0	1	1	1	1	0	001E
Device type	1	0	1	1	1	1	0	0	0	1	00F1

Note: 1. The Atmel AT27BV1024 has the same product identification code as the Atmel AT27C1024. Both are programming compatible

## 6. Rapid programming algorithm

A  $100\mu\text{s}$   $\overline{\text{PGM}}$  pulse width is used to program. The address is set to the first location.  $V_{\text{CC}}$  is raised to 6.5V and  $V_{\text{PP}}$  is raised to 13.0V. Each address is first programmed with one  $100\mu\text{s}$   $\overline{\text{PGM}}$  pulse without verification. Then a verification/reprogramming loop is executed for each address. In the event a word fails to pass verification, up to 10 successive  $100\mu\text{s}$  pulses are applied with a verification after each pulse. If the word fails to verify after 10 pulses have been applied, the part is considered failed. After the word verifies properly, the next address is selected until all have been checked.  $V_{\text{PP}}$  is then lowered to 5.0V and  $V_{\text{CC}}$  to 5.0V. All words are read again and compared with the original data to determine if the device passes or fails.

Figure 6-1. Rapid programming algorithm

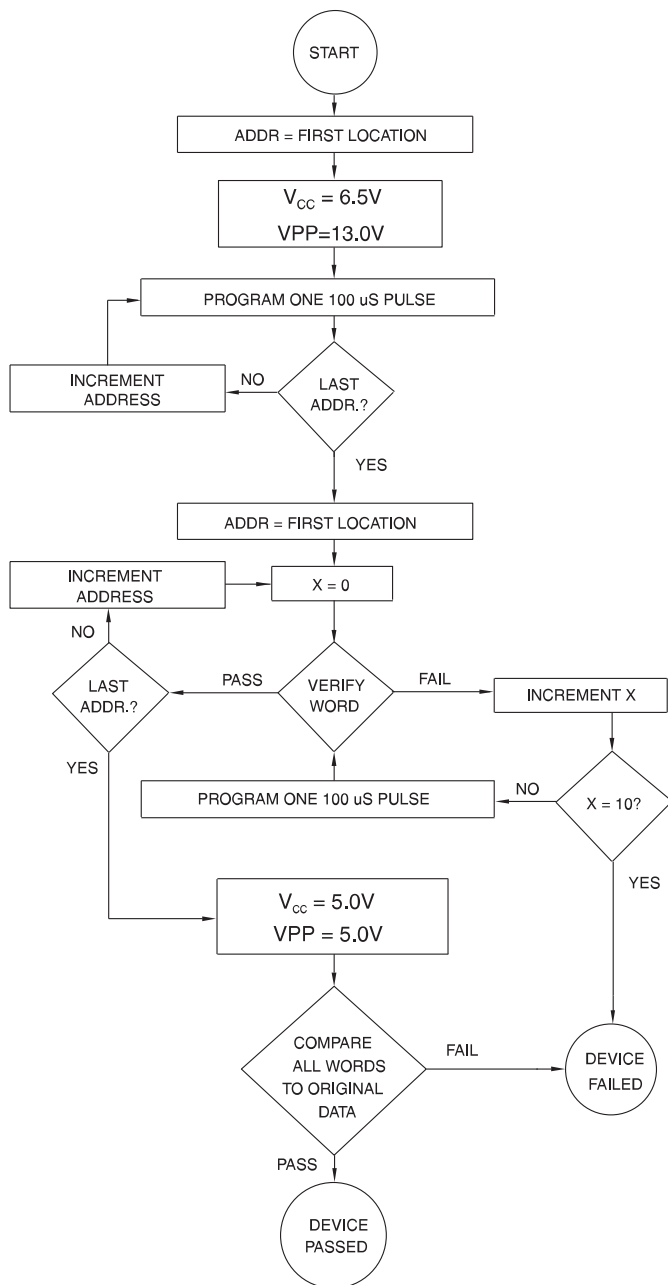

## 7. Ordering information

## Green package (Pb/halide-free)

t <sub>ACC</sub> (ns)	I <sub>CC</sub> (mA)		Atmel ordering code	Lead finish	Package	Operation range
	Active	Standby				
90	8	0.02	AT27BV1024-90JU	Matte tin	44J	Industrial (-40°C to 85°C)

Package type	
44J	44-lead, plastic, J-leaded chip carrier (PLCC)

## 8. Packaging Information

### 44J – PLCC

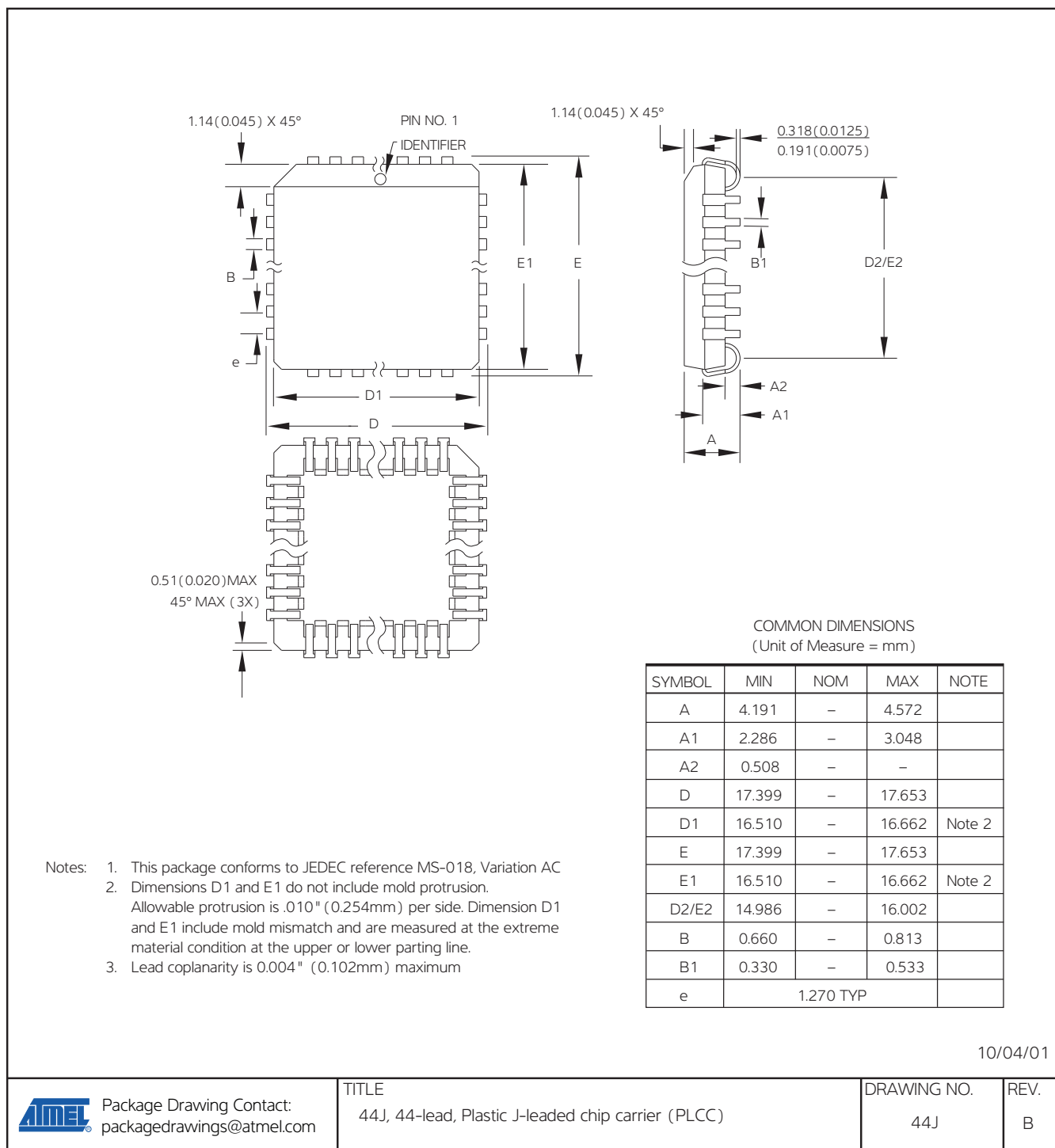

## 9. Revision history

Doc. rev.	Date	Comments
0631F	04/2011	Remove VSOP package Add lead finish to ordering information Change 120ns to 90ns
0631E	12/2007	

**Atmel Corporation**

2325 Orchard Parkway  
San Jose, CA 95131  
USA

**Tel:** (+1) (408) 441-0311

**Fax:** (+1) (408) 487-2600

[www.atmel.com](http://www.atmel.com)

**Atmel Asia Limited**

Unit 01-5 & 16, 19F  
BEA Tower, Millennium City 5  
418 Kwun Tong Road

Kwun Tong, Kowloon

HONG KONG

**Tel:** (+852) 2245-6100

**Fax:** (+852) 2722-1369

**Atmel Munich GmbH**

Business Campus  
Parkring 4  
D-85748 Garching b. Munich  
GERMANY

**Tel:** (+49) 89-31970-0

**Fax:** (+49) 89-3194621

**Atmel Japan**

9F, Tonetsu Shinkawa Bldg.  
1-24-8 Shinkawa  
Chuo-ku, Tokyo 104-0033  
JAPAN

**Tel:** (+81) (3) 3523-3551

**Fax:** (+81) (3) 3523-7581

© 2011 Atmel Corporation. All rights reserved. / Rev.: 0631F-EPROM-4/11

Atmel®, logo and combinations thereof, and others are registered trademarks or trademarks of Atmel Corporation or its subsidiaries. Other terms and product names may be trademarks of others.

Disclaimer: The information in this document is provided in connection with Atmel products. No license, express or implied, by estoppel or otherwise, to any intellectual property right is granted by this document or in connection with the sale of Atmel products. EXCEPT AS SET FORTH IN THE ATMEL TERMS AND CONDITIONS OF SALES LOCATED ON THE ATMEL WEBSITE, ATMEL ASSUMES NO LIABILITY WHATSOEVER AND DISCLAIMS ANY EXPRESS, IMPLIED OR STATUTORY WARRANTY RELATING TO ITS PRODUCTS INCLUDING, BUT NOT LIMITED TO, THE IMPLIED WARRANTY OF MERCHANTABILITY, FITNESS FOR A PARTICULAR PURPOSE, OR NON-INFRINGEMENT. IN NO EVENT SHALL ATMEL BE LIABLE FOR ANY DIRECT, INDIRECT, CONSEQUENTIAL, PUNITIVE, SPECIAL OR INCIDENTAL DAMAGES (INCLUDING, WITHOUT LIMITATION, DAMAGES FOR LOSS AND PROFITS, BUSINESS INTERRUPTION, OR LOSS OF INFORMATION) ARISING OUT OF THE USE OR INABILITY TO USE THIS DOCUMENT, EVEN IF ATMEL HAS BEEN ADVISED OF THE POSSIBILITY OF SUCH DAMAGES. Atmel makes no representations or warranties with respect to the accuracy or completeness of the contents of this document and reserves the right to make changes to specifications and products descriptions at any time without notice. Atmel does not make any commitment to update the information contained herein. Unless specifically provided otherwise, Atmel products are not suitable for, and shall not be used in, automotive applications. Atmel products are not intended, authorized, or warranted for use as components in applications intended to support or sustain life.

## Looking for pricing, stock, or lifecycle information?

Click below to explore more details on WIN SOURCE:

 [View AT27BV1024-90JU on WIN SOURCE](#)

 [Atmel Information](#)

## Optimize Your Supply Chain with WIN SOURCE Solutions

-  Global Sourcing Solution
-  Obsolete Management
-  Cost Control Management
-  Shortage Management
-  Alternative Solution
-  Excess Inventory Management