



**THE DATASHEET OF  
RT8543GQW**



## 6-String 43V White LED Driver with Boost Regulator

### General Description

The RT8543 is a high efficiency white LED driver. It is designed for LCD panel that employs an LED array as the lighting source. An integrated switch current mode Boost controller drives six strings in parallel and supports up to 10 pieces of LEDs per string. The internal current sinks support maximum  $\pm 2\%$  current matching for excellent brightness uniformity in each LED string. To provide enough headroom for the operating of current sink, Boost controller monitors the minimum voltage of feedback pins and regulates an optimized output voltage for power efficiency.

The RT8543 has wide input voltage range from 2.5V to 24V and provides adjustable 5mA to 50mA LED current. The internal 200m $\Omega$ , 43V power switch with current-mode control provides cycle-by-cycle over-current protection. The RT8543 also integrates PWM and analog dimming functions for accurate LED current control. The input PWM dimming frequency can operate from 100Hz to 20kHz without inducing any inrush current in LED or inductor.

The RT8543 is available in thin WQFN-20L 4x4 and UQFN-20L 4x4 packages.

### Applications

- UMPC and Notebook Computer Backlight

### Features

- **Wide Input Voltage** :  $V_{IN}$  2.5V to 24V
- **High Output Voltage** :  $V_{OUT}$  up to 43V
- **Current Mode Boost Regulator**
  - ▶ 600kHz to 1.2MHz Switching Frequency
  - ▶ Up to 85% High Frequency
- **Adjustable Full Channel Current** from 5mA to 50mA and Matched to 2%
- **Channel Current Regulation** with  $\pm 3\%$  Accuracy
- **Dimming Controls**
  - ▶ Direct PWM Dimming up to 20kHz and Minimum On-Time to 500ns
  - ▶ PWM to Analog Dimming up to 20kHz with 8 bit resolution
- **Built-In Soft-Start** to Prevent Inrush Current without External Capacitor
- **Disconnects LED** in Shutdown
- **Protection**
  - ▶ Strings Open Detection
  - ▶ Current Limit Protection
  - ▶ Adjustable Over-Voltage Protection
  - ▶ Over-Temperature Protection
- 20-Lead WQFN and UQFN Package
- RoHS Compliant and Halogen Free

### Simplified Application Circuit

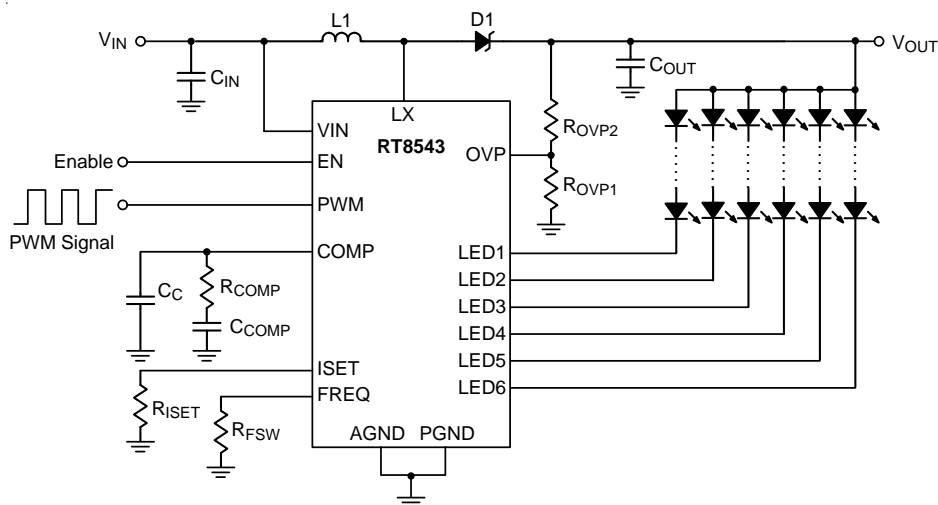

## Ordering Information

RT8543

- Package Type
  - QW : WQFN-20L 4x4 (W-Type)  
(Exposed Pad-Option 1)
  - QU : UQFN-20L 4x4 (U-Type)
- Lead Plating System
  - G : Green (Halogen Free and Pb Free)

Note :

Richtek products are :

- ▶ RoHS compliant and compatible with the current requirements of IPC/JEDEC J-STD-020.
- ▶ Suitable for use in SnPb or Pb-free soldering processes.

## Pin Configuration

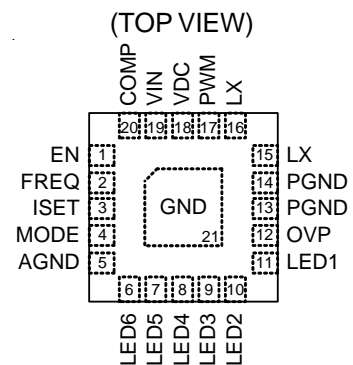

WQFN-20L 4x4 / UQFN-20L 4x4

## Marking Information

RT8543GQW

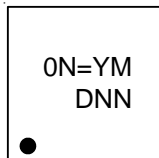

0N= : Product Code  
YMDNN : Date Code

RT8543GQU

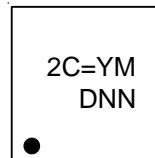

2C= : Product Code  
YMDNN : Date Code

## Functional Pin Description

Pin No.	Pin Name	Pin Function
1	EN	Enable control input (Active High). There is an internal 400kΩ pull-low resistor connected to AGND.
2	FREQ	Switching frequency of boost converter setting input. Connect a resistor to ground.
3	ISET	LED current setting. LED current is set by the value of the resistor R <sub>ISET</sub> connected from the ISET pin to ground. V <sub>ISET</sub> is typically 1V. $I_{LED} (mA) = \frac{1000}{R_{ISET} (k\Omega)}$
4	MODE	Mode selection pin. Floating the MODE pin for PWM dimming mode. Connecting the MODE pin to GND for mixed mode. Connecting the MODE pin to VDC for pure DC mode.
5	AGND	Analog ground of LED driver.
6, 7, 8, 9, 10, 11	LED6 to LED1	Current sink for LED string. (Leave the pin floating or short to GND, if not used.)
12	OVP	Over-voltage protection for boost converter. The detecting threshold is 1.2V.
13, 14	PGND	Power ground of boost converter.
15, 16	LX	The switching for boost converter.
17	PWM	PWM dimming control input.
18	VDC	Internal regulator voltage. Connect a capacitor to ground or floating.
19	VIN	Power supply input for LED driver.
20	COMP	Compensation node for boost converter. Connect a compensation network to ground.
21 (Exposed Pad)	GND	The Exposed Pad must be Soldered to a Large PCB and Connected to GND for Maximum Power Dissipation.

## Functional Block Diagram

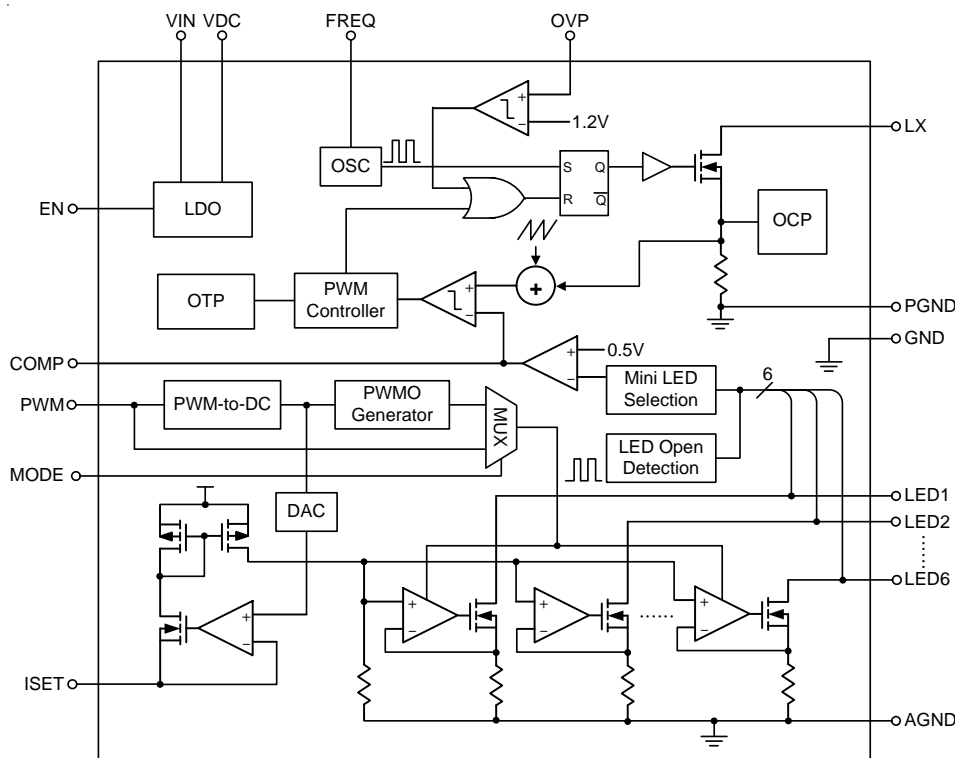

## Operation

### Enable Control

When VIN is higher than the UVLO voltage and the EN pin input voltage is higher than rising threshold, the VDC will be regulated around 3.8V if VIN is higher than 3.8V.

### OSC

The switching frequency is adjustable by the external resistor connected between the FREQ pin and GND.

### PWM Controller

This controller includes some logic circuit to control LX N-MOSFET on/off. This block controls the minimum on-time and max duty of LX.

### OCP & OTP

When LX N-MOSFET peak current is higher than 2.5A (typically), the LX N-MOSFET is turned off immediately and resumed again at next clock pulse. That  $OCP > 2.5A$  and keeps 2ms, IC will be shutdown. When the junction temperature is higher than 150°C (typically),

the LX N-MOSFET will be turned off until the temperature is lower than the 120°C (typically).

### OVP

When the OVP pin voltage is higher than 1.2V, the LX N-MOSFET is turned off immediately to protect the LX N-MOSFET.

### Minimum LED Selection

This block detects all LEDx voltage and select a minimum voltage to EA (Error Amplifier). This function can guarantee the lowest of the LED pin voltage is around 600mV and Vout can be Boost to the highest forward voltage of LED strings.

### LED Open Detection

If the voltage at LEDx pin is lower than 100mV, this channel is defined as open channel and the Minimum LED Selection function will discard it to regulate other used channels in proper voltage.

## Absolute Maximum Ratings (Note 1)

- Supply Input Voltage, VIN to GND ----- -0.3V to 26.5V
- EN, PWM, ISET, COMP, MODE, FREQ to GND ----- -0.3V to 26.5V
- LX, OVP, LED1 to LED6 to GND ----- -0.3V to 48V
- VDC to GND ----- -0.3V to 7V
- Power Dissipation, PD @ TA = 25°C
  - WQFN-20L 4x4 ----- 3.57W
  - UQFN-20L 4x4 ----- 3.57W
- Package Thermal Resistance (Note 2)
  - WQFN-20L 4x4, θJA ----- 28°C/W
  - WQFN-20L 4x4, θJC ----- 7°C/W
  - UQFN-20L 4x4, θJA ----- 28°C/W
  - UQFN-20L 4x4, θJC ----- 7°C/W
- Lead Temperature (Soldering, 10 sec.) ----- 260°C
- Junction Temperature ----- 150°C
- Storage Temperature Range ----- -65°C to 150°C
- ESD Susceptibility (Note 3)
  - HBM (Human Body Model) ----- 2kV
  - MM (Machine Model) ----- 200V

## Recommended Operating Conditions (Note 4)

- Supply Input Voltage, VIN ----- 2.5V to 24V
- Junction Temperature Range ----- -40°C to 125°C
- Ambient Temperature Range ----- -40°C to 85°C

## Electrical Characteristics

(VIN = 5V, TA = 25°C, unless otherwise specified)

Parameter	Symbol	Test Conditions	Min	Typ	Max	Unit	
VIN Quiescent Current	IVIN	PWM = COMP = 0V, not switching	--	3	--	mA	
	IVIN_SW	PWM = COMP = 2V, switching	--	4	--		
VIN Shutdown Current	ISHDN	VIN = 4.5V, EN = 0V	--	--	10	μA	
VIN Under-Voltage Lockout Threshold	VUVLO	VIN rising	2.1	2.3	2.5	V	
		Hysteresis	0.1	0.2	0.3		
<b>Control Input</b>							
EN, PWM, MODE Input Voltage	Logic-High	VIH	VIN = 2.5V to 24V	1.3	--	--	V
	Logic-Low	VIL	VIN = 2.5V to 24V	--	--	0.7	
<b>Boost Converter</b>							
Switching Frequency	fSW	Rfsw = Open	--	0.6	--	MHz	
		Rfsw = 110kΩ	--	0.8	--		
		Rfsw = 59kΩ	--	1	--		
		Rfsw = 38.2kΩ	--	1.2	--		
LX On-Resistance (N-MOSFET)	RLX	VIN > 4.5V	--	0.2	--	Ω	
Minimum On-Time	TMON	fSW = 1MHz	--	80	--	ns	

Parameter	Symbol	Test Conditions	Min	Typ	Max	Unit
Maximum Duty	D <sub>MAX</sub>	f <sub>SW</sub> = 600kHz	88	91	94	%
LX Current Limit	I <sub>LIM</sub>		2.2	2.5	2.8	A
Regulated V <sub>LEDx</sub>	V <sub>LEDx</sub>	Highest LED String, I <sub>LED</sub> = 20mA	--	0.5	--	V
<b>LED Current Programming</b>						
Maximum LED Current	I <sub>FB(MAX)</sub>	MODE = PWM MODE	5	--	50	mA
		MODE = Pure DC Mode, Mixed Mode	8	--	50	
LED Current Accuracy (I <sub>LEDx</sub> - I <sub>SET</sub> ) / I <sub>SET</sub> x 100%	I <sub>LEDA</sub>	I <sub>SET</sub> = 20mA, MODE = PWM Mode	-3	--	3	%
		I <sub>SET</sub> = 20mA, MODE = Mixed Mode, PWM Duty < 25%	-3	--	3	%
		I <sub>SET</sub> = 20mA, MODE = Mixed Mode, PWM Duty = 25% to 100% MODE = Pure DC Mode PWM Duty = 15% to 100%	-3	--	3	%
		I <sub>SET</sub> = 20mA, MODE = Pure DC Mode PWM Duty = 5% to 15%	-5	--	5	%
		I <sub>SET</sub> = 20mA, MODE = Pure DC Mode PWM Duty = 1% to 5%	-8	--	8	%
Current Balance Between CSx (I <sub>CSx</sub> - I <sub>AVG</sub> ) / I <sub>AVG</sub> x 100%	I <sub>LEDM</sub>	I <sub>SET</sub> = 20mA, MODE = PWM Mode	-2	--	2	%
		I <sub>SET</sub> = 20mA, MODE = Mixed Mode, PWM Duty < 25%	-2	--	2	%
		I <sub>SET</sub> = 20mA, MODE = Mixed Mode & Pure DC Mode, PWM Duty = 25% to 100%	-2	--	2	%
		I <sub>SET</sub> = 20mA, MODE = Pure DC Mode, PWM Duty = 5% to 25%	-2	--	2	%
		I <sub>SET</sub> = 20mA, MODE = Pure DC Mode, PWM Duty = 1% to 5%	-5	--	5	%
ISET Pin Voltage	V <sub>ISET</sub>		--	1	--	V
Minimum LED Current	I <sub>LED_mini</sub>		184	200	--	μA
<b>Fault Protection</b>						
OVP Threshold	V <sub>OVP</sub>		1.16	1.2	1.24	V
OVP Fault Threshold	V <sub>OVPF</sub>		--	50	--	mV
Thermal Shutdown Temperature	T <sub>SD</sub>		--	150	--	°C
LED Pin Under-Voltage Threshold	V <sub>LSD</sub>	Un-Connection	--	0.1	--	V

**Note 1.** Stresses beyond those listed under “Absolute Maximum Ratings” may cause permanent damage to the device.

These are stress ratings only, and functional operation of the device at these or any other conditions beyond those indicated in the operational sections of the specifications is not implied. Exposure to absolute maximum rating conditions may affect device reliability.

**Note 2.** θ<sub>JA</sub> is measured under natural convection (still air) at T<sub>A</sub> = 25°C with the component mounted on a high effective-thermal-conductivity four-layer test board on a JEDEC 51-7 thermal measurement standard. θ<sub>JC</sub> is measured at the exposed pad of the package.

**Note 3.** Devices are ESD sensitive. Handling precaution is recommended.

**Note 4.** The device is not guaranteed to function outside its operating conditions.

Typical Application Circuit

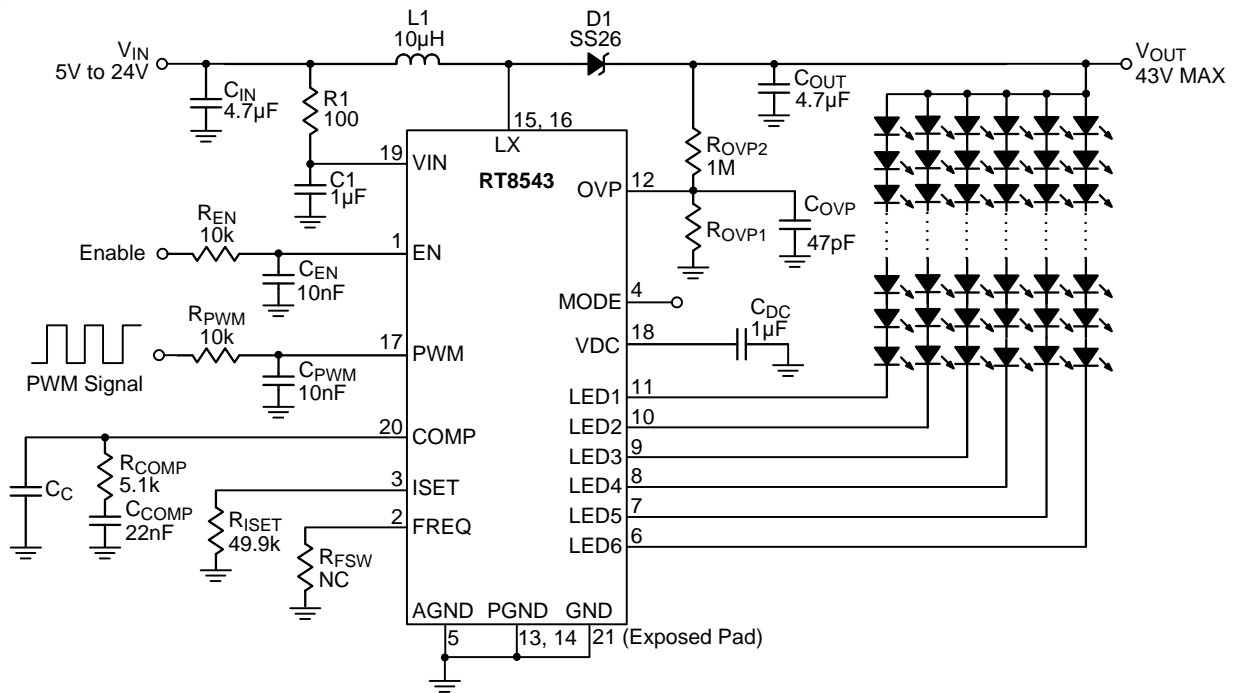

Figure 1. For General Application Circuit

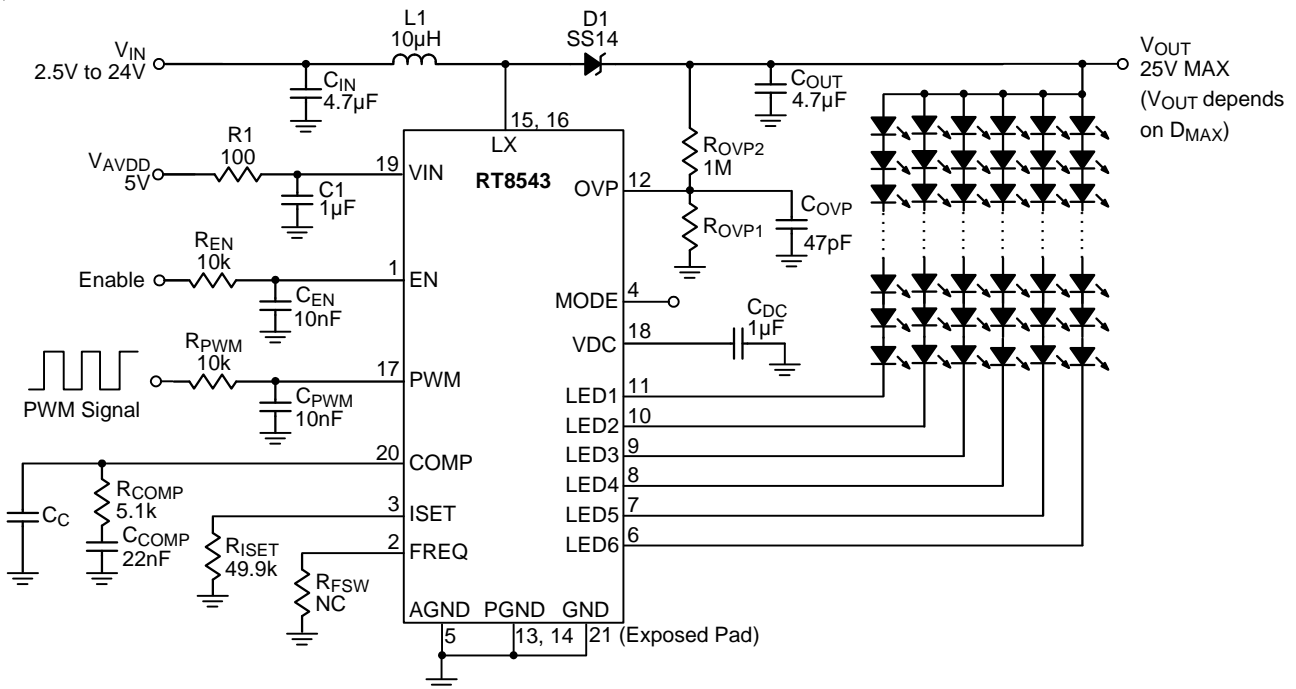
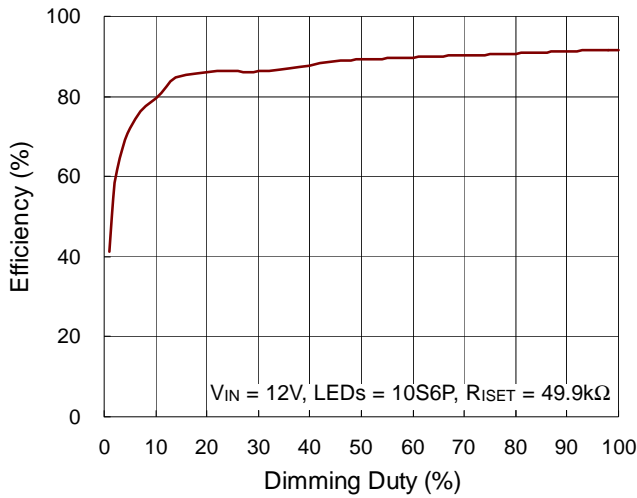

Figure 2. For Low Input Voltage Application Circuit

**Typical Operating Characteristics**

**LED Driver Efficiency**



**LED Current vs. Input Voltage**

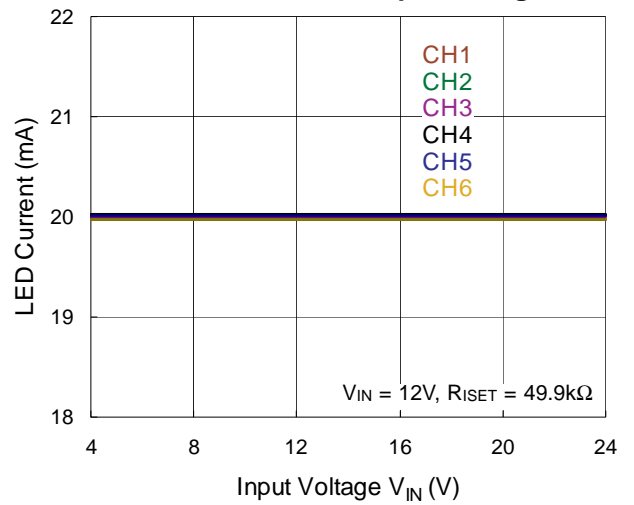

**LED Current vs. PWM Duty Cycle**

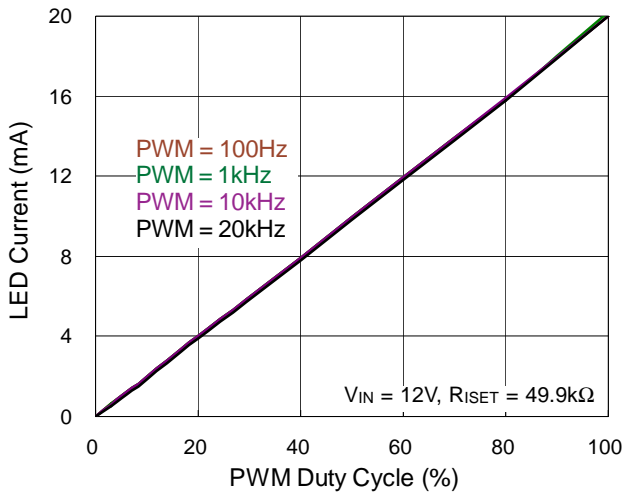

**OVP Threshold Voltage vs. Input Voltage**

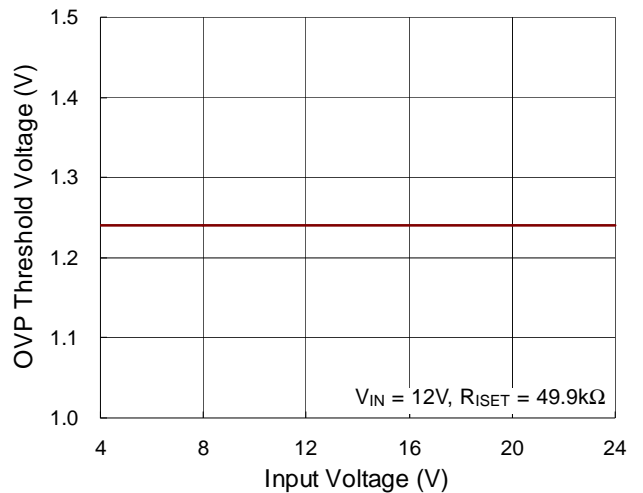

**LED Current vs. Temperature**

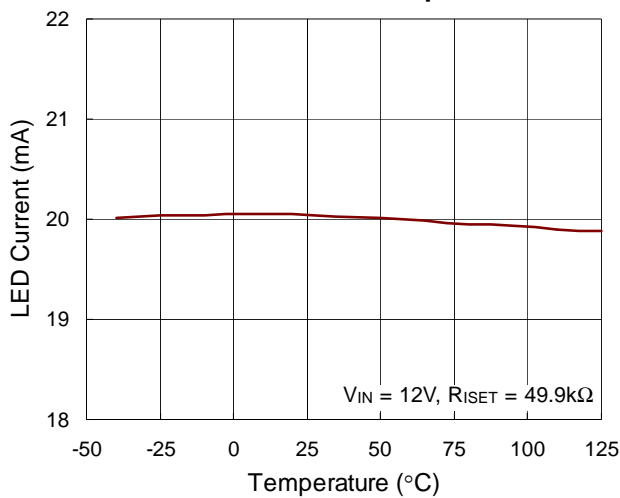

**Quiescent Current vs. Input Voltage**

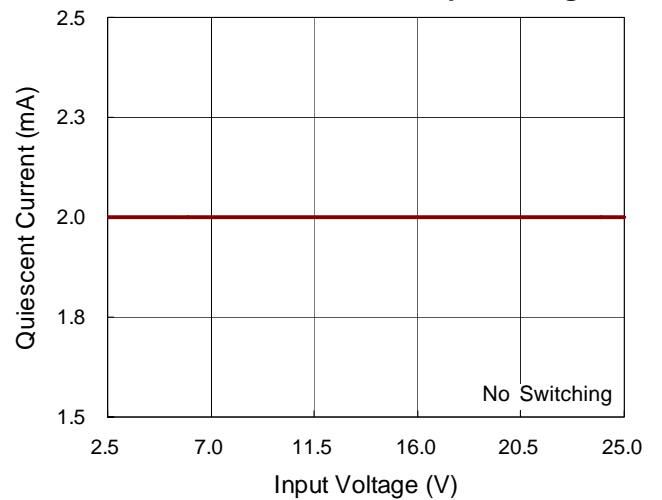

LED Line Transient Response

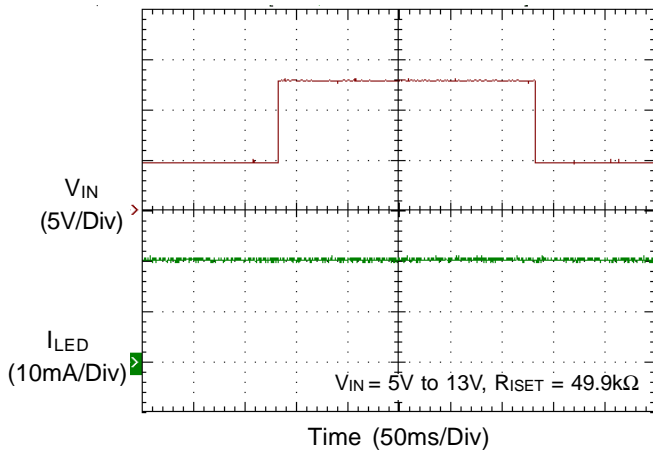

Power On from EN

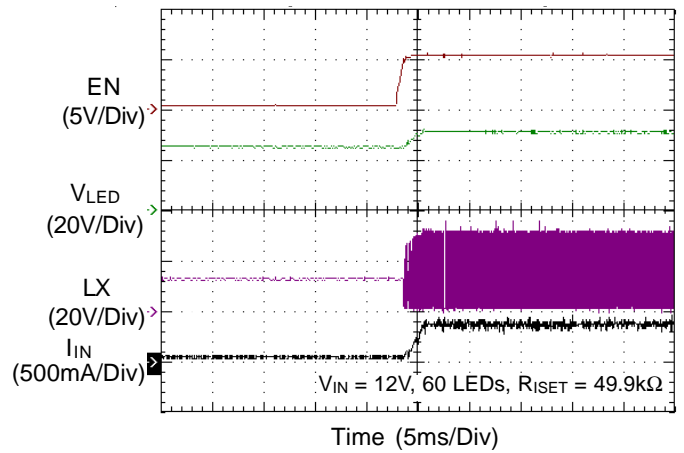

Power On PWM Mode

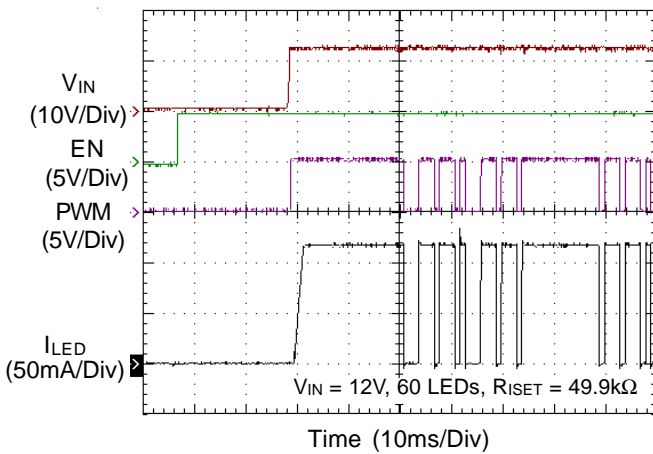

Power On Mixed Mode1

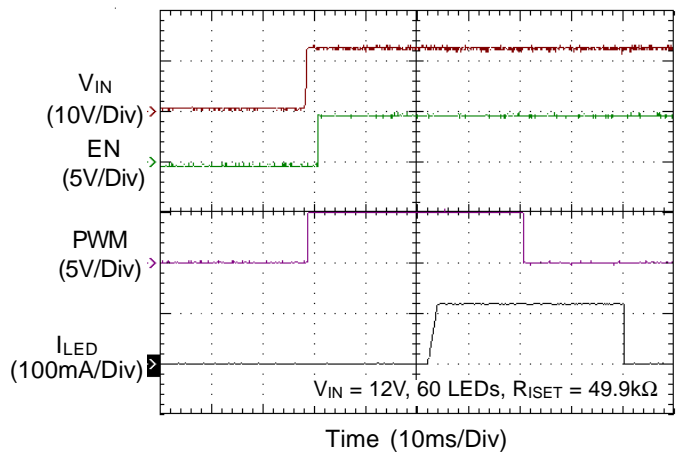

Power On Mixed Mode2

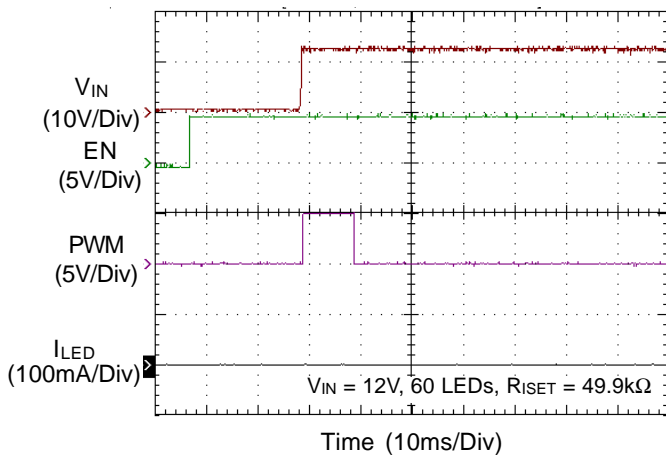

Power On Mixed Mode3

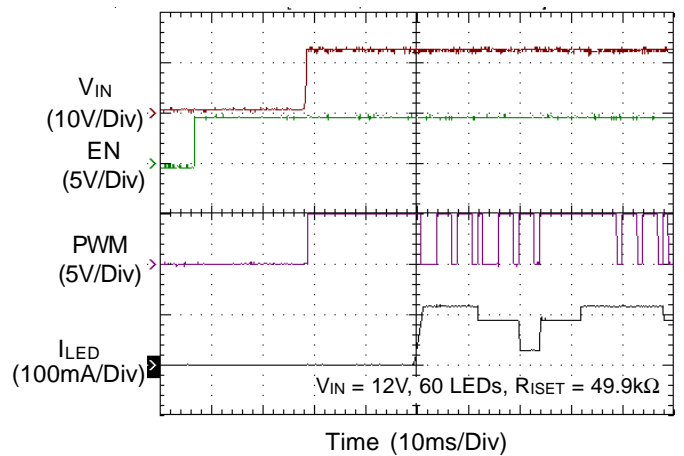

## Application Information

The RT8543 is a general purpose 6-CH LED driver capable of delivering an adjustable 5mA to 50mA LED current. The IC is a current mode Boost converter integrated with a 43V/2.5A power switch and can cover a wide VIN range from 2.5V to 24V. The part integrates built-in soft-start with PWM dimming control provides over voltage, over temperature and current limit protection features. It also integrates PWM and mixed mode dimming function for accurate LED current control. The PWM dimming frequency can operate from 100Hz to 20kHz without inducing any inrush current in LED or inductor.

### LED Power Soft-Start Function

The period from EN is enabled to LED current rises, is several tens of milliseconds according to the brightness dimming mode (PWM Mode or Mixed Mode). The LED current starts up after VIN, PWM and EN signals are all ready. The RT8543 supports soft-start function to reduce inrush current, and the soft-start inrush peak current must be less than 2.5A.

### LED Driver Compensation

The control loop can be compensated by adjusting the external components connected to the COMP pin. The COMP pin is the output of the internal error amplifier. The compensation capacitors, C<sub>C</sub> and C<sub>COMP</sub>, will adjust the zero and pole respectively to maintain stability. Moreover, the resistor, R<sub>COMP</sub>, will adjust the mid-band gain for fast transient response.

### Setting and Regulation of LED Current

The LED current can be calculated by the following equation :

$$I_{LED} = \frac{1000}{R_{ISET}} \quad (\text{mA})$$

where, R<sub>ISET</sub> is the resistor between the ISET pin and GND. This setting is the reference for the LED current at LED1 to LED6 and represents the sensed LED current for each string. The DC/DC converter regulates the LED current according to the setting.

### LED Driver Inductor Selection

The value of the inductor (L) calculated by the following equation determines the criteria of the transition from DCM to CCM mode :

$$L = \frac{(V_{OUT} - V_{IN}) \times V_{IN}^2}{2 \times I_{OUT} \times f_{SW} \times V_{OUT}^2}$$

where,

V<sub>OUT</sub> is the maximum output voltage.

V<sub>IN</sub> is the minimum input voltage.

f<sub>SW</sub> is the switching frequency.

I<sub>OUT</sub> is the sum of current from all LED strings.

The LED Boost converter operates in DCM over the entire input voltage range when the inductor value L1 is less than this value L. With an inductance greater than L, the converter operates in CCM at the minimum input voltage and may be discontinuous at higher voltages. The inductor must be selected with saturation current rating greater than the peak current calculated by the following equation :

$$I_{PEAK} = \frac{(V_{OUT} \times I_{OUT})}{\eta \times V_{IN}} + \left( \frac{V_{IN} \times T_{SW}}{2 \times L} \right) \times \left( \frac{V_{OUT} - V_{IN}}{V_{OUT}} \right)$$

### LED Driver Diode Selection

Schottky diode is a good choice for any asynchronous Boost converter due to its small forward voltage and fast switching speed. However, when selecting a Schottky diode, important parameters such as power dissipation, reverse voltage rating and pulsating peak current must all be taken into consideration. Choose a suitable diode with reverse voltage rating greater than the maximum output voltage.

### LED Driver Capacitor Selection

The input capacitor reduces current spikes from the input supply and minimizes noise injection to the converter. For most applications, a 4.7μF ceramic capacitor is sufficient. A value higher or lower may be used depending on the noise level from the input supply and the input current to the converter. It is recommended to choose a ceramic

capacitor based on the output voltage ripple requirements. The minimum value of the output capacitor,  $C_{OUT}$ , can be calculated by the following equation :

$$C_{OUT} = \frac{(V_{OUT} - V_{IN}) \times I_{OUT}}{17 \times V_{RIPPLE} \times V_{OUT} \times f_{SW}}$$

### PWM Mode / Mixed Mode and Pure DC Mode Brightness Dimming

The RT8543 allows three ways of LED brightness control.

**PWM Mode Dimming :** When the MODE pin is set to float, the dimming mode operates in PWM Mode (Figure 3). During the PWM dimming, the current source turn-on/off is synchronized with the PWM signal. The LED current frequency is equivalent to PWM input frequency.

**Mixed Mode Dimming :** If the MODE pin is set to GND, the dimming mode operates in Mixed Mode (Figure 4). In this mode, the PWM and  $I_{OUT}$  dimming cycle will delay by two periods. First cycle delay is required for the period, while the second cycle delay is for the duty rate calculation.

(a) When  $25\% \leq \text{PWM duty} \leq 100\%$ , the current source outputs are DC dimming, and the PWM duty cycle modulates the amplitude of the currents.

(b) PWM Duty  $< 25\%$ , the DC dimming will translate to DC-PWM dimming to control the LED current. In this state, the LED current is fixed at  $0.25 \times I_{SET}$ , and the dimming duty is  $4 \times \text{PWM duties}$ .

**Pure DC Mode Dimming :** If the MODE pin is set to VDC, the PWM and  $I_{OUT}$  will delay by two periods. First cycle delay is required for the period, while the second cycle delay is for the duty rate calculation.

The minimum D/A converter is 512 steps resolution for  $I_{SET}$  regulation.

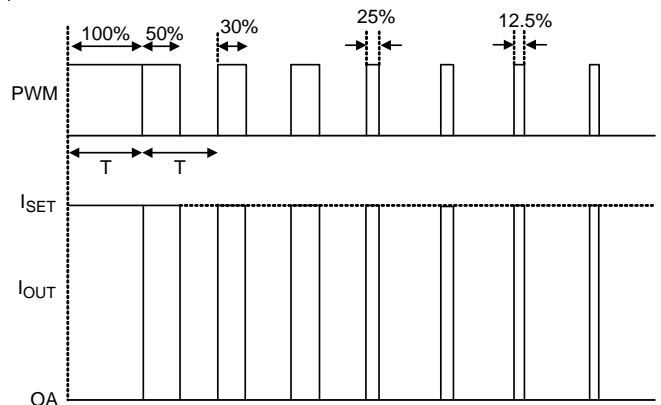

Figure 3. LED Current Control Using PWM Dimming Mode (MODE = Floating)

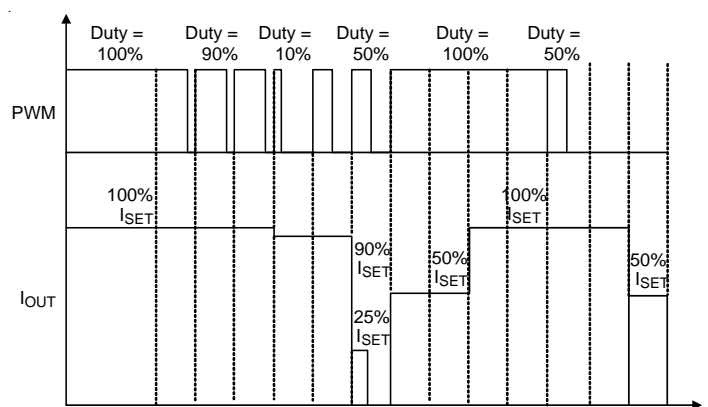

Figure 4. LED Current Control Using Mixed Dimming Mode (MODE = GND)

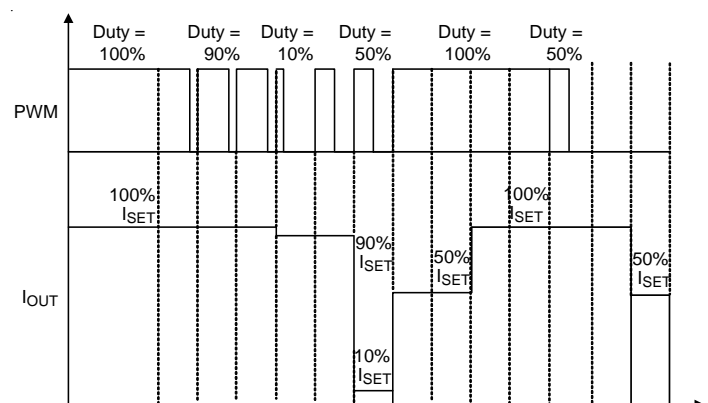

Figure 5. LED Current Control Using Pure DC Dimming Mode (MODE = VDC)

**Brightness Control**

The RT8543 features the digital dimming control scheme. A very high contrast ratio true digital PWM dimming can be achieved by driving PWM pin with a the PWM signal and the recommended PWM frequency is 100Hz to 10kHz. Dimming frequency can be sufficiently adjusted from 100Hz to 20kHz. However, LED current cannot be 100% proportional to duty cycle especially for high frequency and low duty ratio because of physical limitation caused by inductor rising time. Please refer to below Table.

**Table. Input PWM Dimming Frequency vs Minimum Duty ( Mixed, PWM and DC Dimming Mode)**

PWM Input Dimming Frequency	Duty (Min)	Duty (Max)
120Hz to 20kHz	1%	100%

Note : The minimum duty in Table is based on the application circuit and does not consider the deviation of current linearity when  $f_{PWM} > 10kHz$ , ILED may not achieve setting current in duty (min.) due to different  $V_{OUT} / V_{IN}$  ratio at  $V_{IN} = 12V$ .

**LED Driver Under Voltage Lockout (UVLO)**

The UVLO circuit compares the LED driver input voltage at  $V_{IN}$  with the UVLO threshold (2.3V rising, typ.) to ensure the input voltage is high enough for reliable operation. The 200mV (typ.) hysteresis prevents supply transients from causing a shutdown. Once  $V_{IN}$  exceeds the UVLO rising threshold, the LED soft-start will begin after a delay time around several milliseconds. When  $V_{IN}$  falls below the UVLO falling threshold, the controller turns off all LED driver functions.

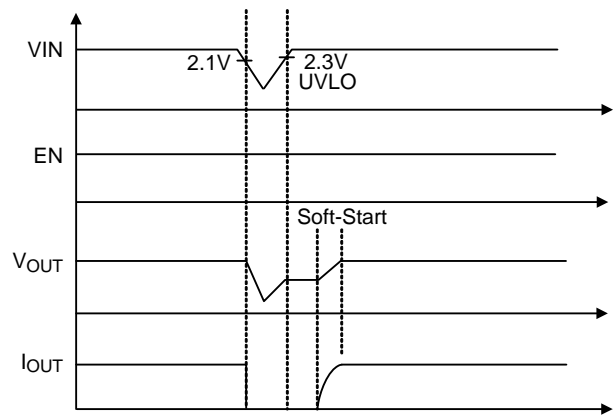

Figure 6. LED UVLO Function

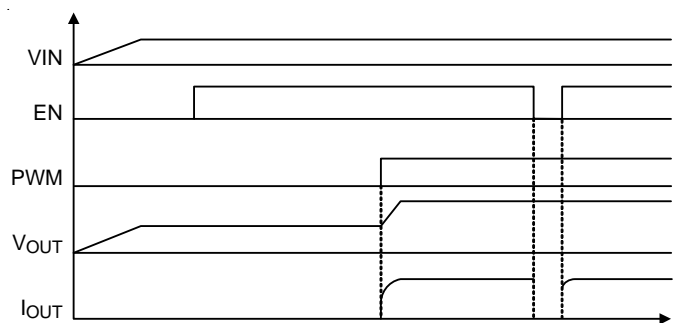

Figure 7. LED Driver Power On Sequence (PWM Mode)

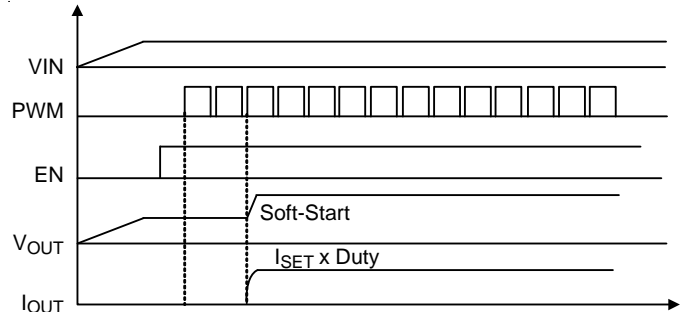

Figure 8. LED Driver Power On Sequence (Mixed Mode)

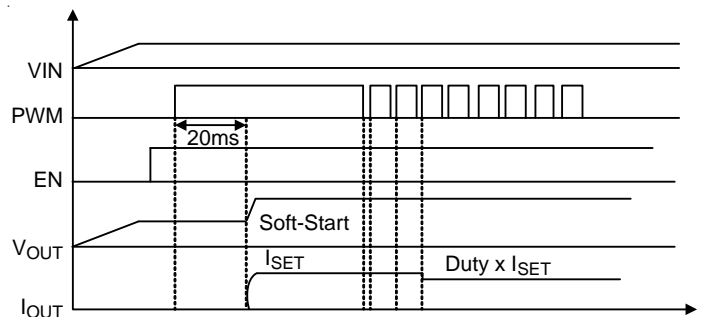

Figure 9. LED Driver Power On Sequence (Mixed Mode; Duty = 100%)

### LED Channel Open Circuit Protection

If at least one channel is in normal operation, the LED driver will automatically ignore the open channels and continue to regulate current for the channels in normal operation.

### LED Driver Over Voltage Protection

The LED driver equips an Over Voltage Protection (OVP) function. When the voltage at the OVP pin reaches a threshold of approximately 1.2V, the driver will turn off. The drivers turn on again once the voltage at OVP drops below the threshold voltage. Thus, the output voltage can be clamped at a certain voltage level. This voltage level can be calculated by the following equation :

$$V_{OUT, OVP} = V_{OVP} \times \left( 1 + \frac{R_{OVP2}}{R_{OVP1}} \right)$$

where  $R_{OVP1}$  and  $R_{OVP2}$  are the resistors in the voltage divider connected to close to the OVP pin. It is suggested to use 400kΩ to 1MΩ for  $R_{OVP2}$  to reduce loading effect.

### Over Temperature Protection

The RT8543 includes an Over Temperature Protection (OTP) feature to prevent overheating due to excessive power dissipation from damaging the device. The OTP function will shut down LED driver when the junction temperature exceeds 150°C. It will reactivate the device when powered on again. To maintain continuous operation, the junction temperature should be kept below 125°C.

### Thermal Considerations

The junction temperature should never exceed the absolute maximum junction temperature  $T_{J(MAX)}$ , listed under Absolute Maximum Ratings, to avoid permanent damage to the device. The maximum allowable power dissipation depends on the thermal resistance of the IC package, the PCB layout, the rate of surrounding airflow, and the difference between the junction and ambient temperatures. The maximum power dissipation can be calculated using the following formula :

$$P_{D(MAX)} = (T_{J(MAX)} - T_A) / \theta_{JA}$$

where  $T_{J(MAX)}$  is the maximum junction temperature,  $T_A$  is the ambient temperature, and  $\theta_{JA}$  is the junction-to-ambient thermal resistance.

For continuous operation, the maximum operating junction temperature indicated under Recommended Operating Conditions is 125°C. The junction-to-ambient thermal resistance,  $\theta_{JA}$ , is highly package dependent. For a WQFN-20L 4x4 package, the thermal resistance,  $\theta_{JA}$ , is 28°C/W on a standard JEDEC 51-7 high effective-thermal-conductivity four-layer test board. For a UQFN-20L 4x4 package, the thermal resistance,  $\theta_{JA}$ , is 28°C/W on a standard JEDEC 51-7 high effective-thermal-conductivity four-layer test board. The maximum power dissipation at  $T_A = 25^\circ\text{C}$  can be calculated as below :

$$P_{D(MAX)} = (125^\circ\text{C} - 25^\circ\text{C}) / (28^\circ\text{C/W}) = 3.57\text{W} \text{ for a WQFN-20L 4x4 package.}$$

$$P_{D(MAX)} = (125^\circ\text{C} - 25^\circ\text{C}) / (28^\circ\text{C/W}) = 3.57\text{W} \text{ for a UQFN-20L 4x4 package.}$$

The maximum power dissipation depends on the operating ambient temperature for the fixed  $T_{J(MAX)}$  and the thermal resistance,  $\theta_{JA}$ . The derating curves in Figure 10 allows the designer to see the effect of rising ambient temperature on the maximum power dissipation.

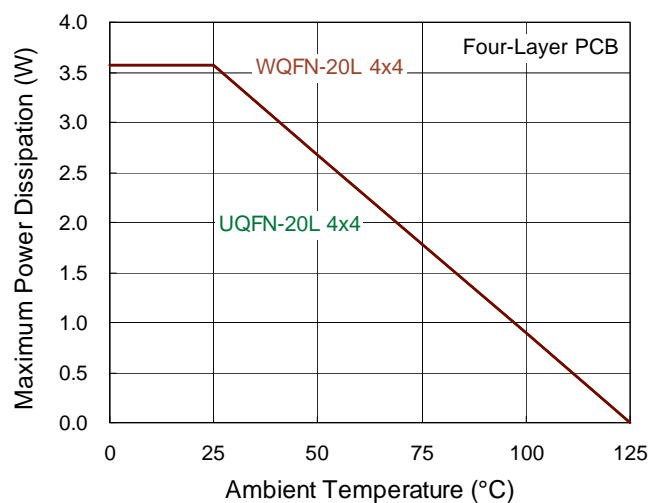

Figure 10. Derating Curve of Maximum Power Dissipation

**Layout Considerations**

PCB layout is very important to design power switching converter circuits. The following layout guide lines should be strictly followed for best performance of the RT8543.

- ▶ The power components L1, D1, C<sub>IN</sub> and C<sub>OUT</sub> must be placed as close as possible to reduce the ac current loop. The PCB trace between power components must be short and wide as possible due to large current flow through these trace during operation.

- ▶ Place L1 and D1 connected to LX pins as close as possible. The trace should be short and wide as possible.
- ▶ It is recommend to place C1 close to VIN pin.
- ▶ Pin 20 is the compensation point to adjust system stability. Place the compensation components to pin 20 as close as possible.

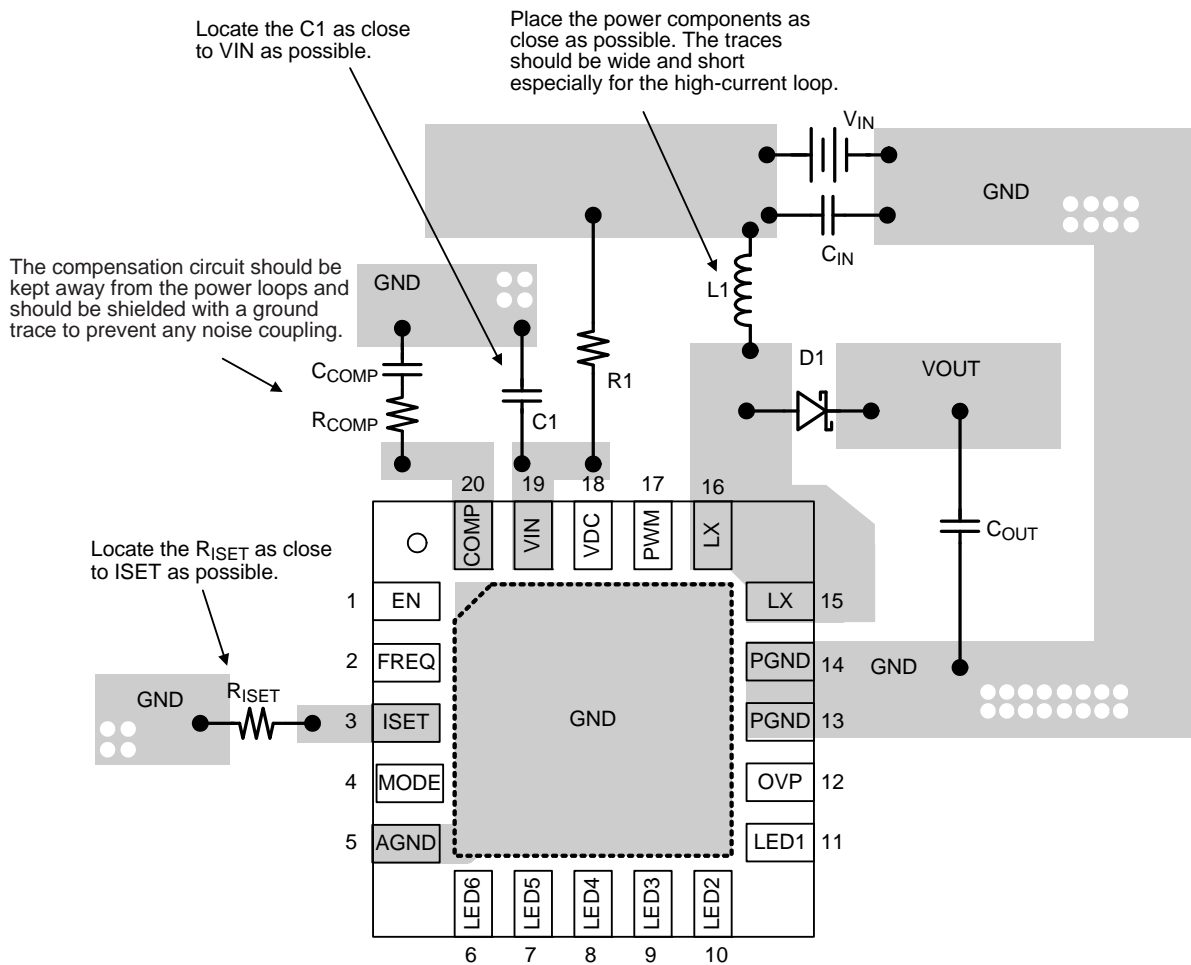
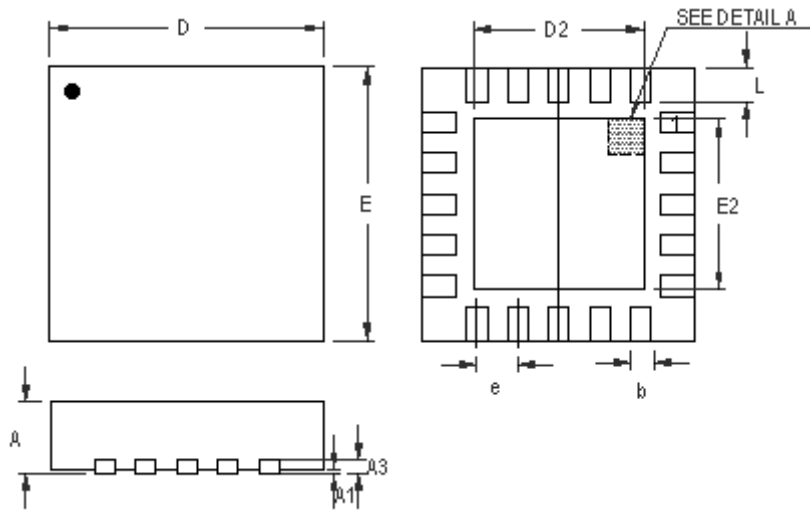

Figure 11. PCB Layout Guide

Outline Dimension



**DETAIL A**

Pin #1 ID and Tie Bar Mark Options

Note : The configuration of the Pin #1 identifier is optional, but must be located within the zone indicated.

Symbol	Dimensions In Millimeters		Dimensions In Inches		
	Min	Max	Min	Max	
A	0.700	0.800	0.028	0.031	
A1	0.000	0.050	0.000	0.002	
A3	0.175	0.250	0.007	0.010	
b	0.150	0.300	0.006	0.012	
D	3.900	4.100	0.154	0.161	
D2	Option 1	2.650	2.750	0.104	0.108
	Option 2	2.100	2.200	0.083	0.087
E	3.900	4.100	0.154	0.161	
E2	Option 1	2.650	2.750	0.104	0.108
	Option 2	2.100	2.200	0.083	0.087
e	0.500		0.020		
L	0.350	0.450	0.014	0.018	

W-Type 20L QFN 4x4 Package

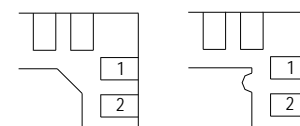
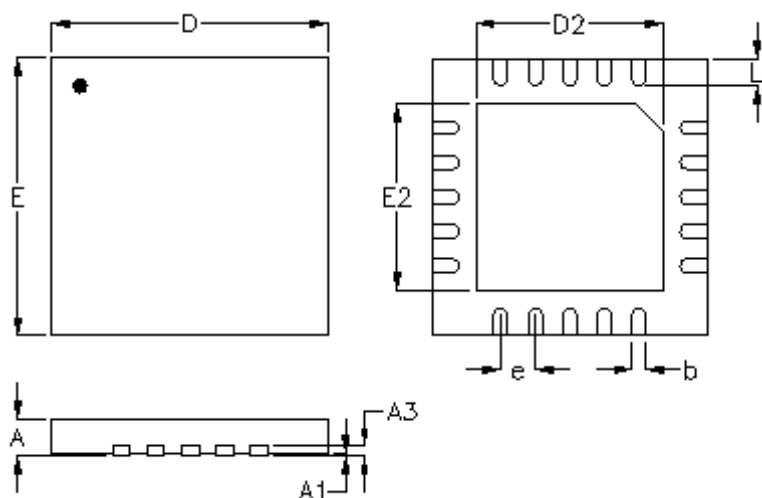

**DETAILA**

Pin #1 ID and Tie Bar Mark Options

Note : The configuration of the Pin #1 identifier is optional, but must be located within the zone indicated.

Symbol	Dimensions In Millimeters		Dimensions In Inches	
	Min.	Max.	Min.	Max.
A	0.500	0.600	0.020	0.024
A1	0.000	0.050	0.000	0.002
A3	0.100	0.175	0.004	0.007
b	0.150	0.250	0.006	0.010
D	3.900	4.100	0.154	0.161
D2	2.650	2.750	0.104	0.108
E	3.900	4.100	0.154	0.161
E2	2.650	2.750	0.104	0.108
e	0.500		0.020	
L	0.350	0.450	0.014	0.018

**U-Type 20L QFN 4x4 Package**

**Richtek Technology Corporation**

14F, No. 8, Tai Yuen 1<sup>st</sup> Street, Chupei City  
 Hsinchu, Taiwan, R.O.C.  
 Tel: (8863)5526789

Richtek products are sold by description only. Richtek reserves the right to change the circuitry and/or specifications without notice at any time. Customers should obtain the latest relevant information and data sheets before placing orders and should verify that such information is current and complete. Richtek cannot assume responsibility for use of any circuitry other than circuitry entirely embodied in a Richtek product. Information furnished by Richtek is believed to be accurate and reliable. However, no responsibility is assumed by Richtek or its subsidiaries for its use; nor for any infringements of patents or other rights of third parties which may result from its use. No license is granted by implication or otherwise under any patent or patent rights of Richtek or its subsidiaries.

## Looking for pricing, stock, or lifecycle information?

Click below to explore more details on WIN SOURCE:

 [View RT8543GQW on WIN SOURCE](#)

 [Richtek USA Inc. Information](#)

## Optimize Your Supply Chain with WIN SOURCE Solutions

-  Global Sourcing Solution
-  Obsolete Management
-  Cost Control Management
-  Shortage Management
-  Alternative Solution
-  Excess Inventory Management