



**THE DATASHEET OF  
TW8832S-LB1-GR**



# TW8832, TW8832S

## TFT Display Controller

 FN7855  
 Rev. 4.00  
 May 6, 2014

### Description

The TW8832 incorporates many of the features required to create multi-purpose in-car LCD display system in a single package. It integrates a high quality 2D comb NTSC/PAL/SECAM video decoder, triple high speed RGB ADCs, high quality scaler, and images enhancement functions, which include Black and White Stretch, etc. It also supports panoramic scaling for conversion to wide screen display. On the input side, it supports a rich combination of CVBS, S-video, analog RGB as well as digital inputs. On the output side, it supports a variety of digital panel types with its built-in timing controller.

### Applications

- In-car display controller
- Portable DVD and DVRs players
- Portable media player

### Features

#### Analog Video Decoder

- NTSC (M, 4.34) and PAL (B, D, G, H, I, M, N, N combination), PAL (60), SECAM with automatic format detection
- Three 10-bit ADCs and analog clamping circuit
- Fully programmable static gain or automatic gain control for the Y or CVBS channel
- Programmable white peak control for the Y or CVBS channel
- Software selectable analog inputs
- High quality adaptive 2D comb filter for both NTSC and PAL inputs
- PAL delay line for color phase error correction
- Image enhancement with 2D dynamic peaking and CTI
- Digital sub-carrier PLL for accurate color decoding
- Digital horizontal PLL and Advanced synchronization processing for VCR playback and weak signal performance
- Programmable hue, brightness, saturation, contrast and sharpness
- High quality horizontal and vertical filtered down scaling with arbitrary scale down ratio

#### Analog RGB Inputs

- Triple high speed 10-bit ADCs with clamping and programmable gain amplifier
- SOG and H/V sync support for YPbPr or RGB input
- Built-in line locked PLL with sync separator
- Support analog input resolution up to 1080i or WXGA

#### Digital Inputs Support

- Support 656 video formats

#### TFT Panel Support

- Built-in programmable timing controller
- Supports 3, 4, 6 or 8 bits per pixel up to 16.8 million colors with built-in dithering engine
- Support digital panel up to WVGA/SVGA resolution
- Support Serial (8-bit) RGB panel

#### On Screen Display

- 256 programmable font RAM and 384 display RAM
- Four windows font OSD with bordering / shadow
- Supports bit-mapped based OSD through SPI (TW8832S only)

#### Image Processing

- High quality scaler with both up/down and nonlinear scaling support
- Built-in 2D de-interlacing function
- Programmable hue, brightness, saturation, contrast and sharpness
- Supports programmable cropping of input video and graphics
- Independent RGB gain and offset controls
- Panorama/Water-glass scaling
- Programmable 10-bit Gamma correction for each color
- Operated in Frame Sync mode
- Black/White Stretch

### Clock Generation

- Spread spectrum clock
- Modulation frequency and spread width are selectable

### Power Management

- Supports functional based independent power down
- 1.8/3.3 V operation

### Miscellaneous

- Supports 2-wire serial bus interface
- Built-in single LED back light controller
- Built-in VCOM DC voltage
- Built-in VCOM analog amplitude
- Built-in DC-DC convertor
- Single 27MHz crystal
- 80-pin LQFP package

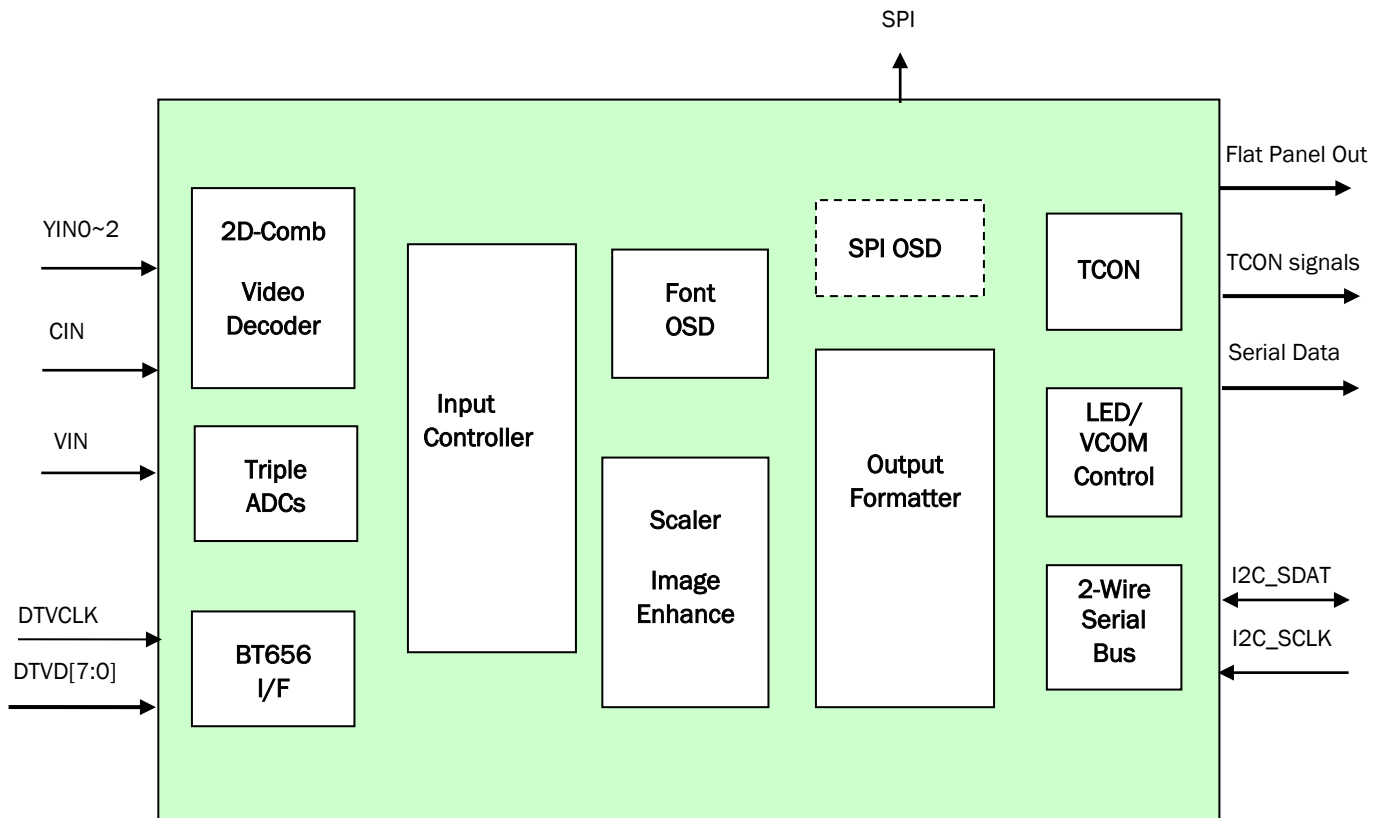

FIGURE 1. FUNCTIONAL BLOCK DIAGRAM

© Copyright Intersil Americas LLC 2011-2014. All Rights Reserved.  
All trademarks and registered trademarks are the property of their respective owners.

For additional products, see [www.intersil.com/product\\_tree](http://www.intersil.com/product_tree)  
Intersil products are manufactured, assembled and tested utilizing ISO9001 or TS16949 quality systems as applicable noted  
in the quality certifications found at <http://www.intersil.com/en/support/qualandreliability.html>

---



*Intersil products are sold by description only. Intersil may modify the circuit design and/or specifications of products at any time without notice, provided that such modification does not, in Intersil's sole judgment, affect the form, fit or function of the product. Accordingly, the reader is cautioned to verify that datasheets are current before placing orders. Information furnished by Intersil is believed to be accurate and reliable. However, no responsibility is assumed by Intersil or its subsidiaries for its use; nor for any infringements of patents or other rights of third parties which may result from its use. No license is granted by implication or otherwise under any patent or patent rights of Intersil or its subsidiaries.*

---

For information regarding Intersil Corporation and its products, see <http://www.intersil.com>

## Looking for pricing, stock, or lifecycle information?

Click below to explore more details on WIN SOURCE:

-  [View TW8832S-LB1-GR on WIN SOURCE](#)
-  [Renesas Electronics America](#) Information

## Optimize Your Supply Chain with WIN SOURCE Solutions

-  Global Sourcing Solution
-  Obsolete Management
-  Cost Control Management
-  Shortage Management
-  Alternative Solution
-  Excess Inventory Management