



THE DATASHEET OF LDS6202NTGI



PureTouch^{®*} Low Channel Capacitive Touch Sensor IC Family

FEATURES

- **Up to 8 touch sensor channels**
 - **2ms update rate per active sensor input****
- **Built-in Slider/Scroll Support**
- **Configurable hysteresis and debounce**
- **Touch Preference Modes**
- **1.65-5.5v supply voltage**
- **Low touch sensor operating power**
 - **Full power mode (typ): <125uW*****
 - **Optional low power mode**
- **On-chip automatic calibration algorithm**
- **I²C compatible serial I/F with VDDIO**
- **Power on touch detection**
- **Configurable for proximity sensing**
- **GPIO and interrupt output**
- **3mm x 3mm 16-pin and 20-pin TQFN packages**
 - **SOIC packages also available**

APPLICATIONS

- **Mobile handsets, personal media players**
- **Portable navigation devices**
- **Remote controls**
- **Office equipment, multi-function printers**
- **Set top boxes**
- **Home appliances**
- **Brown goods**
- **Industrial controls**

DESCRIPTION

The LDS6200 Family of capacitive touch controllers enables streamlining of the human-machine interface through the implementation of touch-based user inputs such as touch buttons, sliders, and scroll wheels. Employing a finely tuned sigma-delta capacitance-to-digital converter and proprietary noise-filtering algorithms, each device is able to reliably sense small changes in capacitance, allowing touch-based inputs to replace a side variety of mechanical input types. On-chip automatic calibration accounts for environmental changes such as temperature, humidity, and dust and is executed automatically.

The LDS6200 Family consists of four products with up to 8 capacitive sensor input pins.

Part #	Touch Sensors	Package
LDS6201	Up to 2	16ld TQFN
LDS6202	Up to 4	16ld SOIC
LDS6203	Up to 6	20ld TQFN
LDS6204	Up to 8	20ld SOIC

The LDS6200 Family supports touch sensor supply voltages from 1.65 to 5.5V. All parts support I²C compatible serial interfaces and offer both a General Purpose I/O (GPIO) and VDDIO support, enabling 1.65V to 5.5V voltage interface support. Typical touch sensor operating power for the device is less than 125uW***. Package offerings include thin form factor 3mm x 3mm 16-pin TQFN, 3mm x 3mm 20-pin TQFN, 3.9mm x 9.9mm 16-pin SOIC, 7.5mm x 12.8mm 20-pin SOIC.

* PureTouch is a registered trademark of IDT

** Nominal decimation rate (d=1024), per sensor input

*** 1.8V, excluding VDDIO current, which varies with VDDIO voltage, I/F type, and communication frequency

TYPICAL APPLICATION CIRCUIT FOR DUAL SUPPLY VOLTAGES

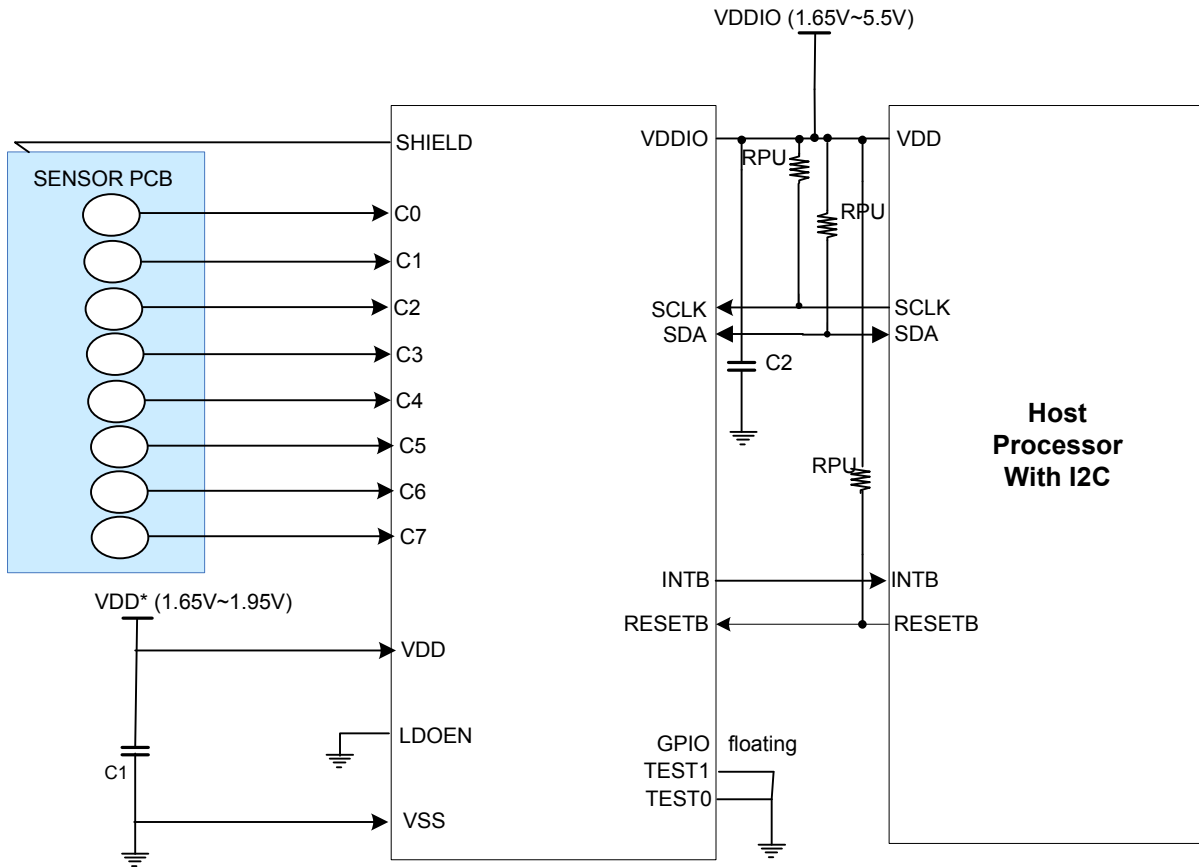

C1, C2 > 1uF

*For direct application of 1.8V voltage.

Figure 1: Application Circuit with I²C I/F using dual voltage sources

TYPICAL APPLICATION CIRCUIT FOR SINGLE SUPPLY VOLTAGE

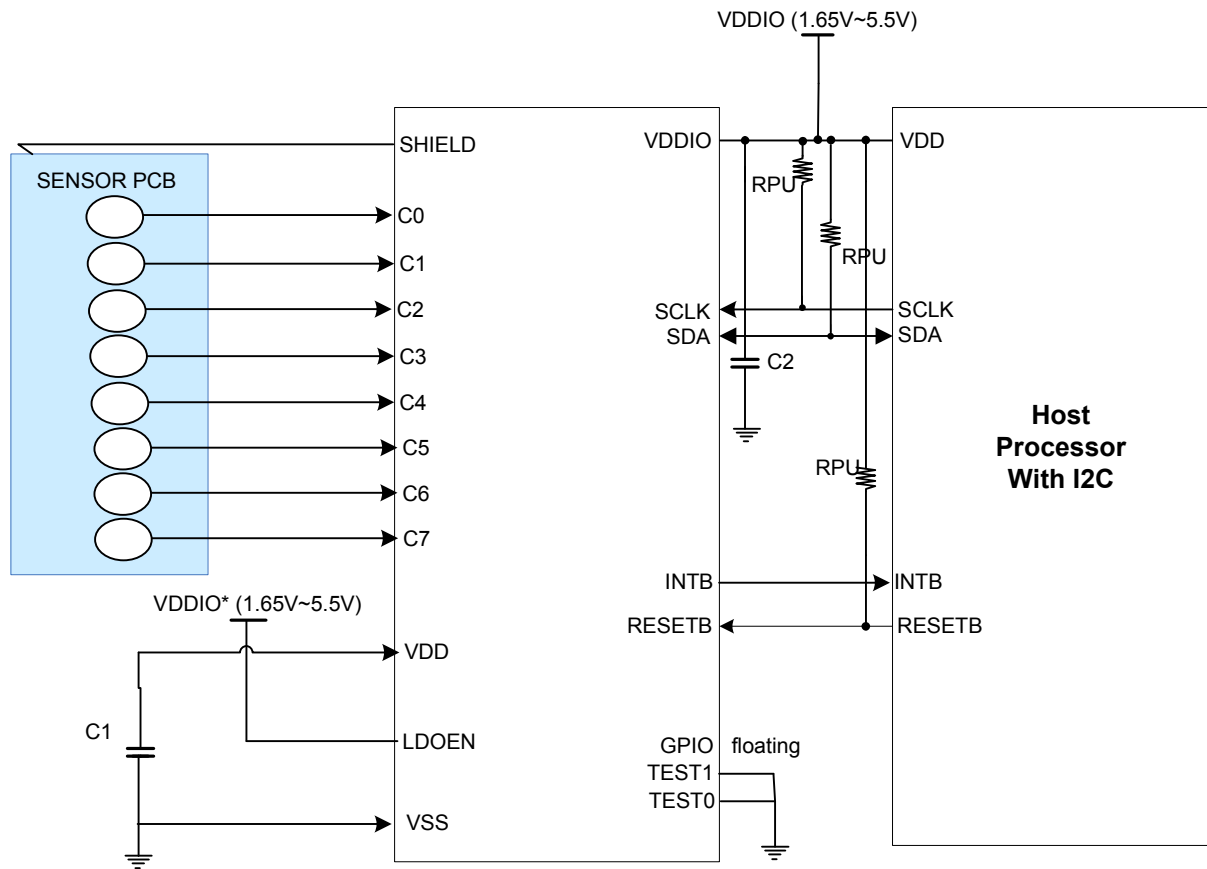

C1, C2 > 1uF

*For voltages >1.95V, apply voltage to VDDIO and tie VDD to ground through C1

Figure 2: Application Circuit with I²C I/F using single voltage source

ABSOLUTE MAXIMUM RATINGS

Item	Symbol	Rating	Unit
Touch Sensor Supply Voltage	VDD	-0.3 to +6.0	V
Serial Interface Operating Voltage	VDDIO	-0.3 to +6.0	V
Input voltage range (Digital)	VIN	-0.3 to VDDIO +0.3	V
Input voltage range (Analog)	AVIN	-0.3 to VDD +0.3	V
Output voltage range (Digital)	VOH	-0.3 to VDDIO +0.3	V
Output voltage range (Analog)	AVOH	-0.3 to VDD +0.3	V
Operating Temperature Range	T _{OPR}	-40 to +85	°C
Storage Temperature Range	T _{STG}	-55 to +125	°C

ESD PROTECTION LEVEL

Model	Test condition	Rating	Unit
Human Body Model	C = 100pF, R = 1.5kΩ	8000	V
Charge Device Model	Charging Resistor = 300MΩ	1500	V
Machine Model	C = 200pF, R = 0Ω	400	V

RECOMMENDED OPERATING CONDITIONS

Parameter	Condition	Unit
VDD*	1.65 to 1.95	V
VDDIO	1.65 to 5.5	V
Ambient Temperature Range	-40 to +85	°C

* For supply voltages >1.95V, apply to VDDIO pin and tie VDD pin to GND through C1
Typical application circuit shown on page 3

ELECTRICAL OPERATING CHARACTERISTICS

VDD = 1.8V, VDDIO = 1.8V T_{AMB} = -40°C to +85°C unless otherwise specified

Parameter	Symbol	Conditions	Related Pins	Min	Typ	Max	Unit
Power & Operating Voltage							
Operating Voltage(1) : Touch*	VDD	-	VDD	1.65	1.8	1.95	V
Operating Voltage(3) : Touch - I/O	VDDIO	-	VDDIO	1.65	-	5.5	V
Logic Inputs							
High Level Input Voltage	VIH	-	(*1)	0.7*VDDIO			V
Low Level Input Voltage	VIL	-	(*1)	VSS		0.3*VDDIO	V
Input Leakage Current	IIL	VIN= VDDIO or VSS	(*1)	-1			uA
Logic Outputs							
High Level Output Voltage	VOH	IOH= -1mA	(*2)	0.8*VDDIO			V
Low Level Output Voltage	VOL	IOL= +1mA	(*2)			0.2*VDDIO	V
Capacitance-to-Digital Converter							
CDC Update Rate per Active Sensor	Tcdc	(*3)		1.95	2.05	2.15	ms
CIN Input Leakage	IILcin	IOH= -1mA	C0~Cx				nA
Sensor Capacitance	Csensor					25 (*4)	pF

* For supply voltages >1.95V, apply to VDDIO pin, set LDOEN to logic high, and tie VDD1 pin to GND through C1
Typical application circuits shown on page 2 and 3

NOTE: (*1): SCLK, SDA, GPIO; (*2): SDA, INTB, GPIO; (*3) DECIMATION RATE = 1024, PER UTILIZED SENSOR; (*4): MAXIMUM SENSOR CAPACITANCE MAY BE ALLOWED TO EXCEED 25PF DEPENDING UPON SYSTEM CONDITIONS – CONTACT IDT FOR EXCEPTION CONDITIONS

ELECTRICAL OPERATING CHARACTERISTICS (CURRENT CONSUMPTION)

VDD = 1.8V, VDDIO = 1.8V, T_{AMB} = -40 °C to 85 °C unless otherwise specified

Parameter	Symbol	Conditions	Related Pins	Min	Typ	Max	Unit
Current Consumption							
Full Power Mode	Iddfp				55	100	uA
Sleep Mode	Iddsl				17		uA
Shutdown, T _{AMB} = 25 °C	Iddsd	T _{AMB} = 25 °C			0.5	5	uA
Shutdown	Iddsd	T _{AMB} = -40 °C to +85 °C				10	uA

I²C-COMPATIBLE TIMING SPECIFICATIONS

For VDD = 1.65-1.95V, VDDIO = 1.65V to 5.5V, over ambient temperature range -40°C to +85°C.

Parameter	Tmin	Tmax	Unit	Description
f _{SCLK}		400	kHz	SCLK clock frequency
t _R		300	ns	Clock/data rise time
t _F		300	ns	Clock/data fall time
t _{HD:STA}	0.6		μs	Start condition hold time
t _{SLW}	1.3		μs	Clock low period
t _{SHW}	0.6		μs	Clock high period
t _{SU:DAT}	100		ns	Data setup time
t _{HD:DAT}	0		ns	Data hold time
t _{SU:STO}	0.6		μs	Stop condition setup time
t _{SU:STA}	0.6		μs	Start condition setup time
t _{BUF}	1.3		μs	Bus free time between stop and start conditions
t _{SP}		50	ns	Max spike width suppressed by SCLK and SDA inputs
t _{VD:DAT}		0.9	μs	Data valid time
t _{VD:ACK}		0.9	μs	Data valid acknowledge time

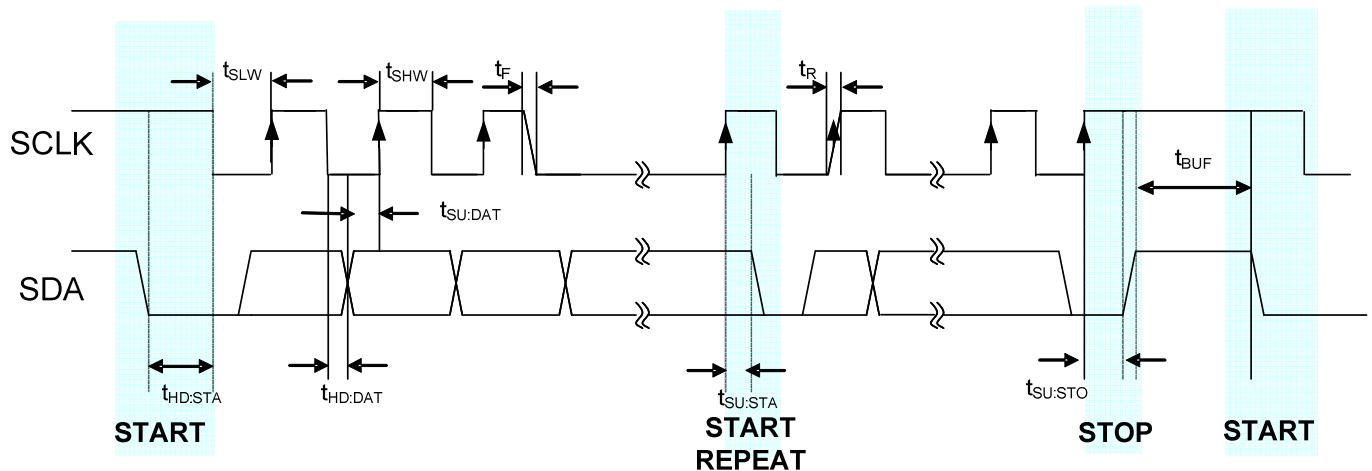

Figure 3: I²C-Compatible Detailed Timing Diagram

WRITING AND READING OVER THE I²C-COMPATIBLE INTERFACE

The LDS6200 Family is always a slave on the I²C interface bus and uses the **7-bit device address of 0101 100**. Data transfer utilizes 8-bit bytes, with the master initiating a data transfer (START) by taking SDA from high-to-low while keeping SCLK high, followed by the 7-bit device address plus a read/write bit dictating the direction of data transfer (**read=1, write=0**). Data is sent over a series of 9 clock pulses made up of 8 bits of data and an acknowledge bit from the LDS6200 Family. The STOP condition occurs when SDA is taken from low-to-high while keeping SCLK high, upon which the LDS6200 Family resets its address pointer to 0x000 and the serial interface pins enter the idle state. Data must be transitioned when the clock signal is low and remain stable when SCLK is high, as a low-to-high transition on SDA when SCLK is high would be interpreted as a STOP signal.

WRITING DATA OVER I²C

The device address (0101 100) and read/write bit (0 for writing) are sent over the bus, followed by two data bytes containing the 10-bit register address to be written. The upper and lower register address bits are shown below:

MSB							LSB	
7	6	5	4	3	2	1	0	
X	X	X	X	X	X	Register Addr Bit 9	Register Addr Bit 8	

MSB							LSB	
7	6	5	4	3	2	1	0	
Register Addr Bit 7	Register Addr Bit 6	Register Addr Bit 5	Register Addr Bit 4	Register Addr Bit 3	Register Addr Bit 2	Register Addr Bit 1	Register Addr Bit 0	

The third and fourth data bytes contain the 8 MSBs and LSBs, respectively, to be written to the internal register pointed to by the 10-bit register address.

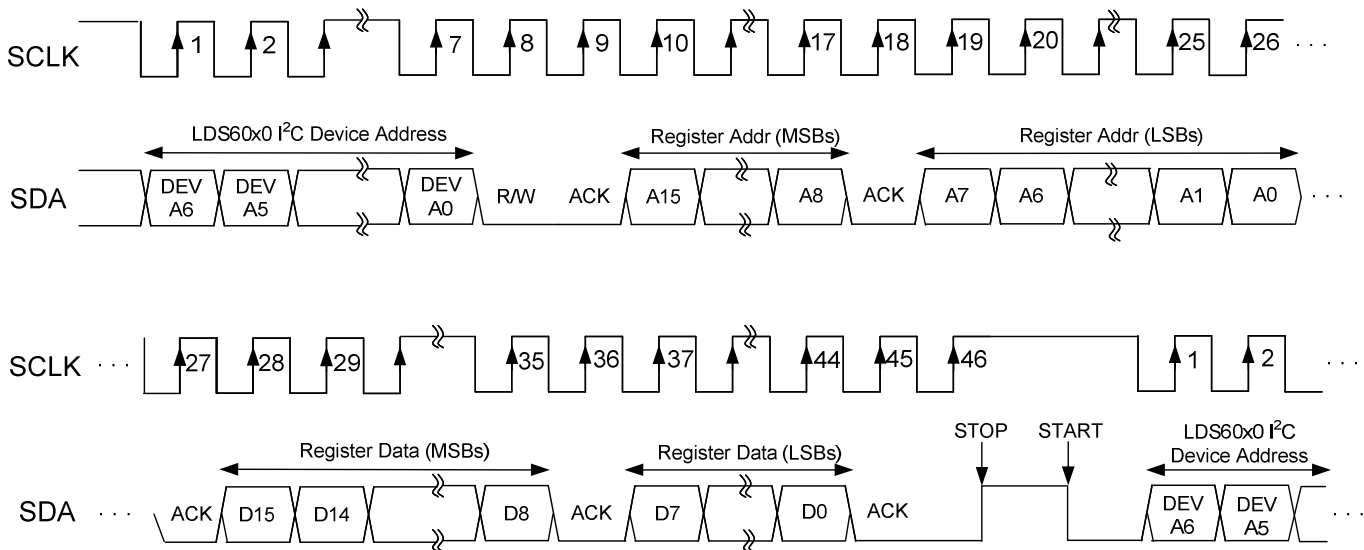

Figure 4: I²C-Compatible Register Write

The LDS6200 Family automatically increments the address pointer enabling sequential writes to registers in the same write transaction. Finishing the transaction involves the master generating a stop condition on SDO or repeat start condition if the I²C link is to remain active.

READING DATA OVER I2C

To initiate a read operation, the master must first write the read starting address to the LDS6200 Family. The device address (0101 100) and read/write bit (0 for initial write of starting address) is sent over the bus, followed by two data bytes that contain the 10-bit register address to be read. The address format is identical to that used during write operations, with only the 10 lower bits of the 16-bit address word containing address information.

The master then either ends the write operation with a STOP signal followed by initiation (START) of a read operation, or more ideally, issues a "REPEAT START" command. In both cases, the read/write bit is set to "1" (see Figure 9 for details of both continuations methods). In either case, the LDS6200 Family provides the MSB eight bits of data first, followed by the LSB eight bits in the next byte.

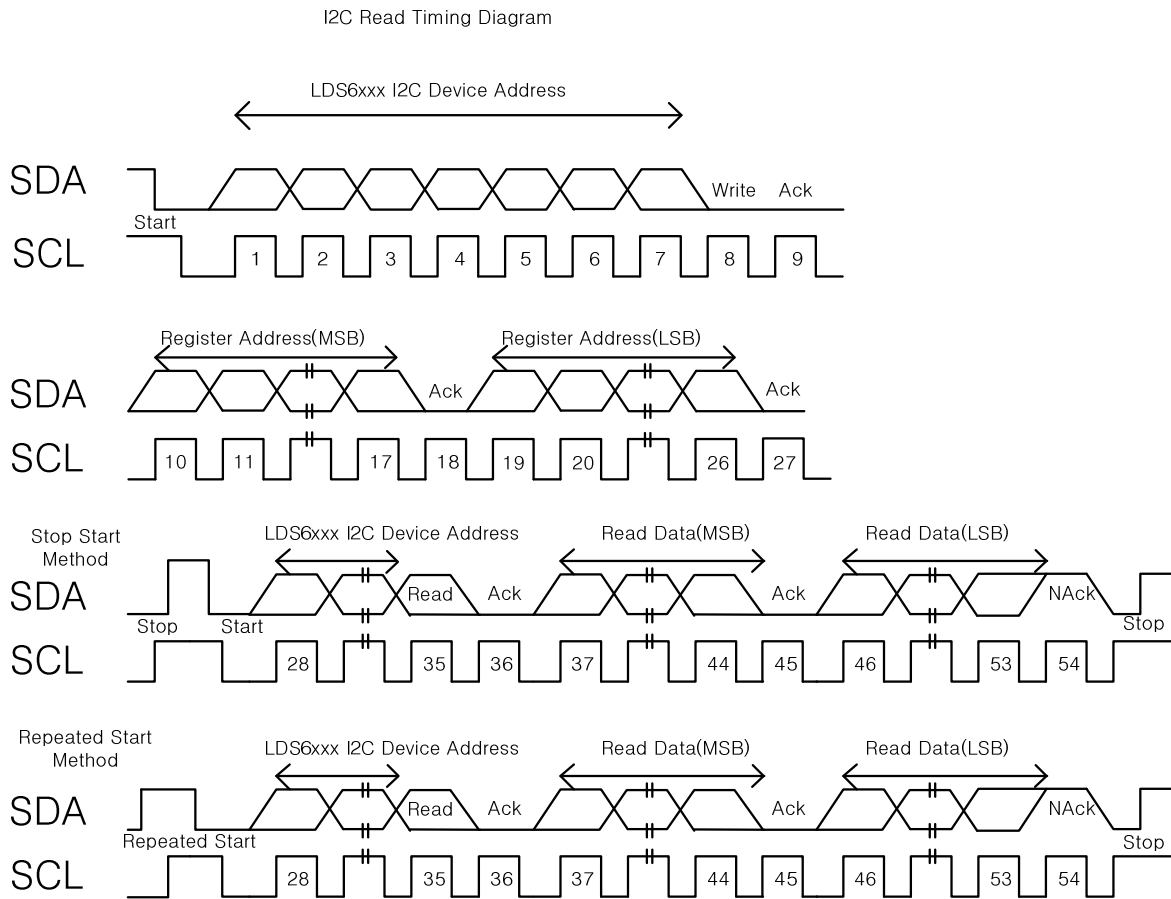

Figure 5: I²C-Compatible Detailed Timing Diagram

The LDS6200 Family address pointer automatically increments after each read, resulting in a continuous output of read data until the master returns a no acknowledge (ACK signal high) and stop condition to the bus. If the address pointer reaches its maximum value and the master continues to attempt to read from the part, the LDS6200 Family continues to send data from the last register that was addressed.

LDS6200 Family



DEVICE PINOUTS (QFN)

LDS6201NTGI

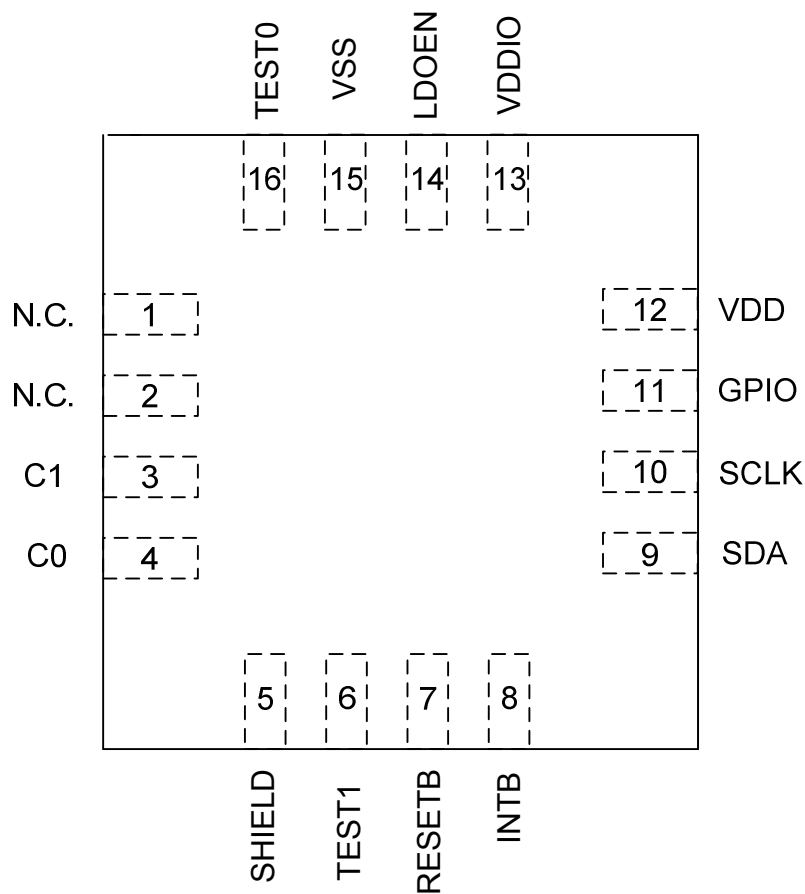

LDS6202NTGI

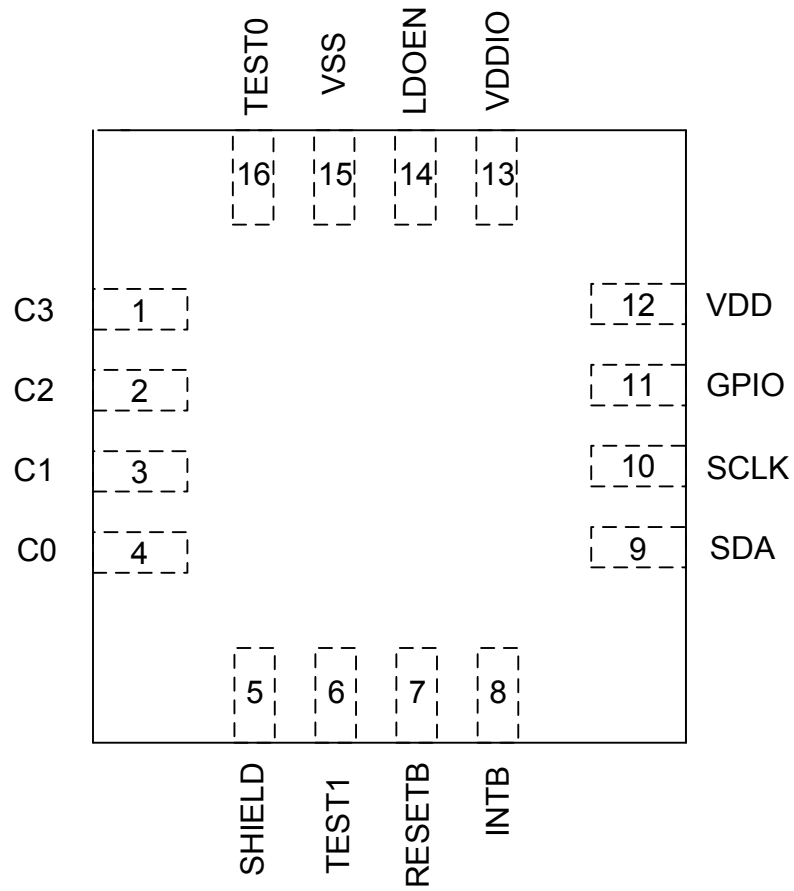

LDS6200 Family



LDS6203NTGI

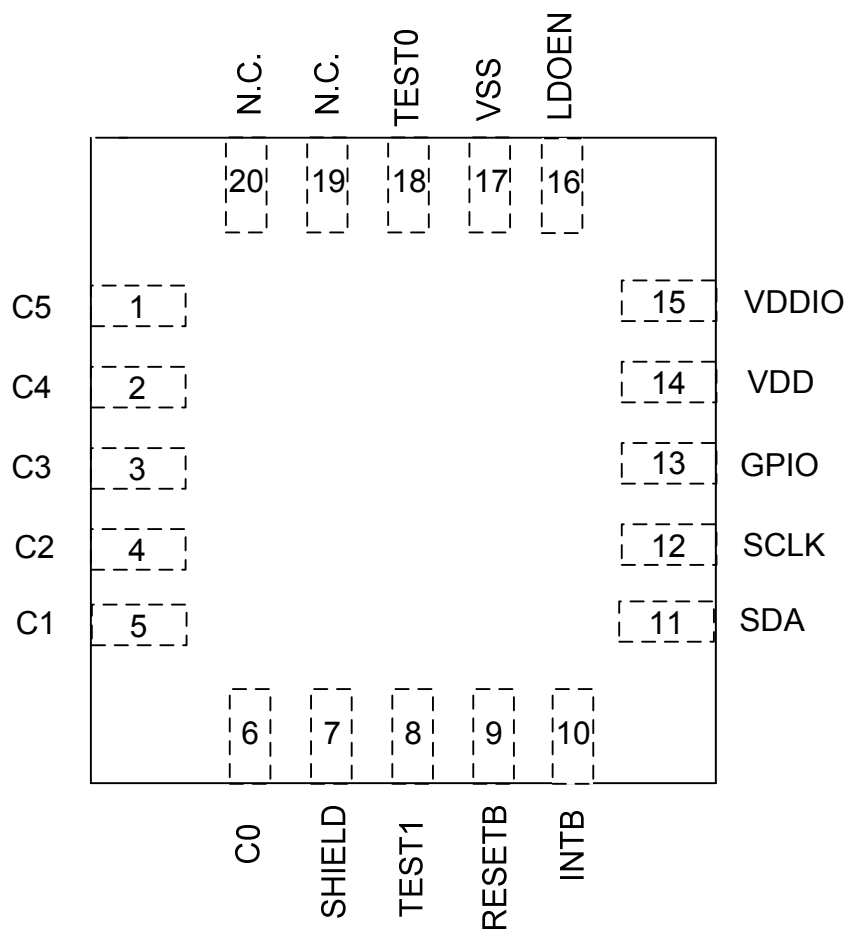

LDS6200 Family



DEVICE PINOUTS (SOIC)

LDS6201DCGI

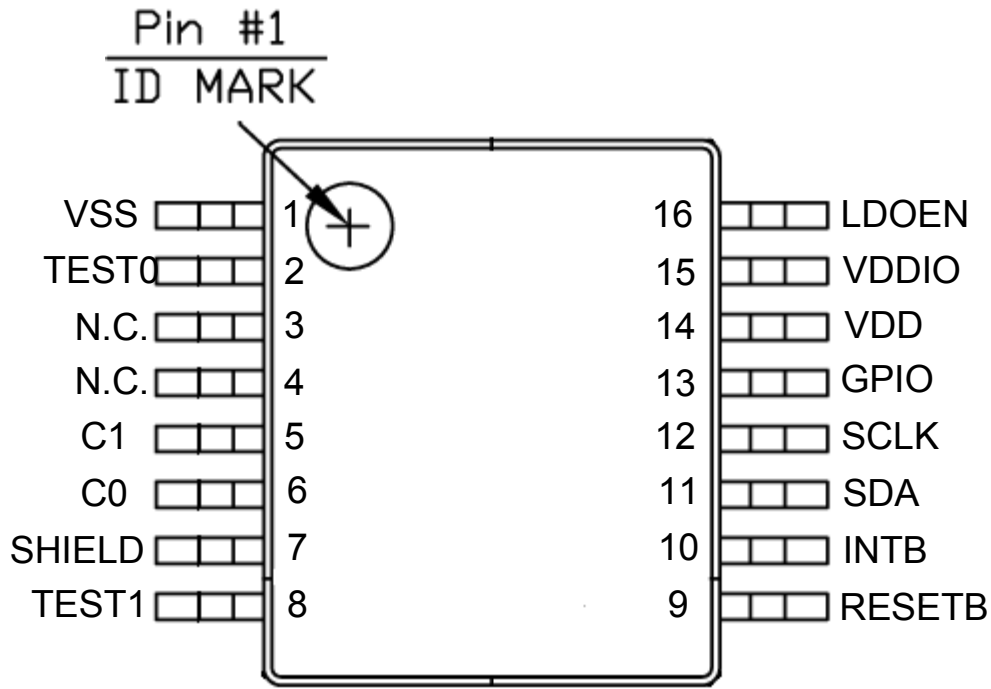

LDS6200 Family



LDS6202DCGI

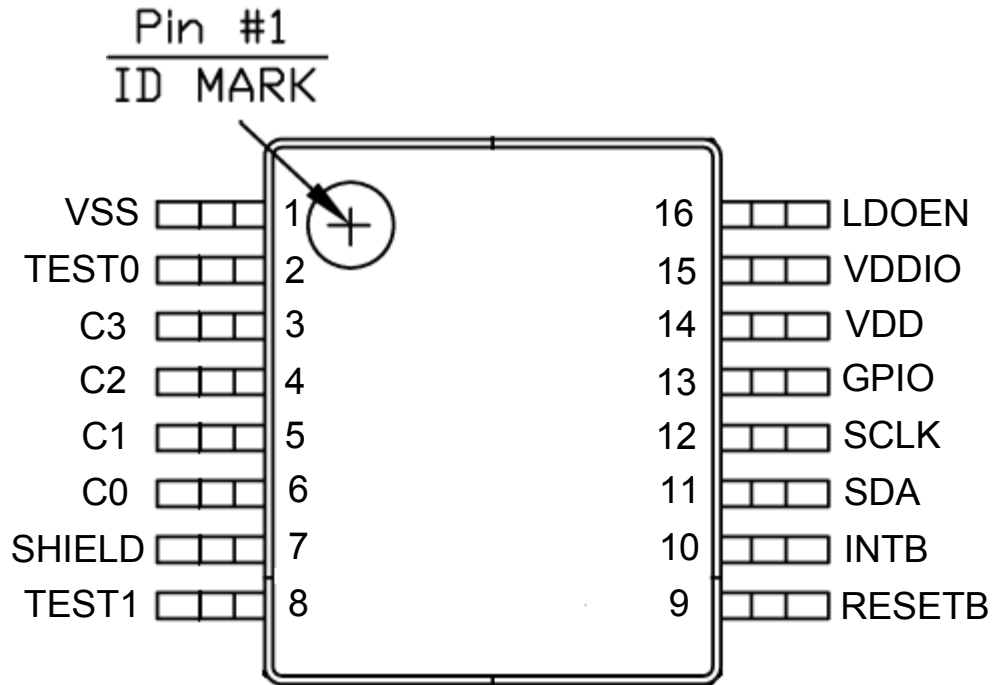

LDS6203SOGI

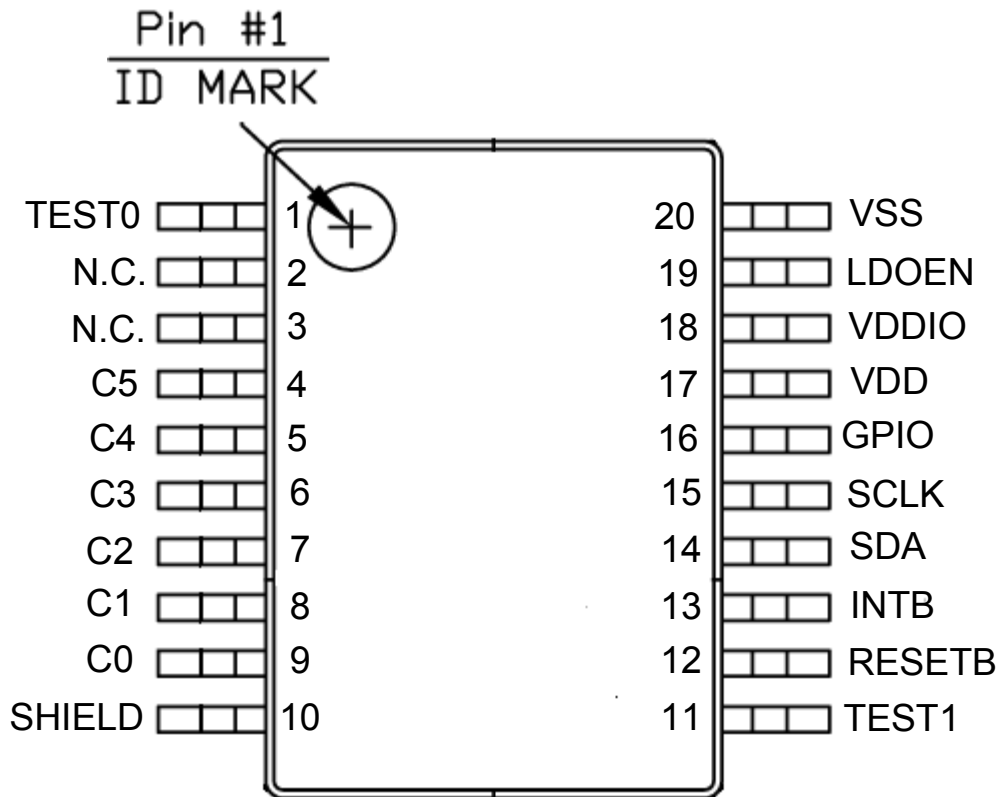

LDS6200 Family



LDS6204SOGI

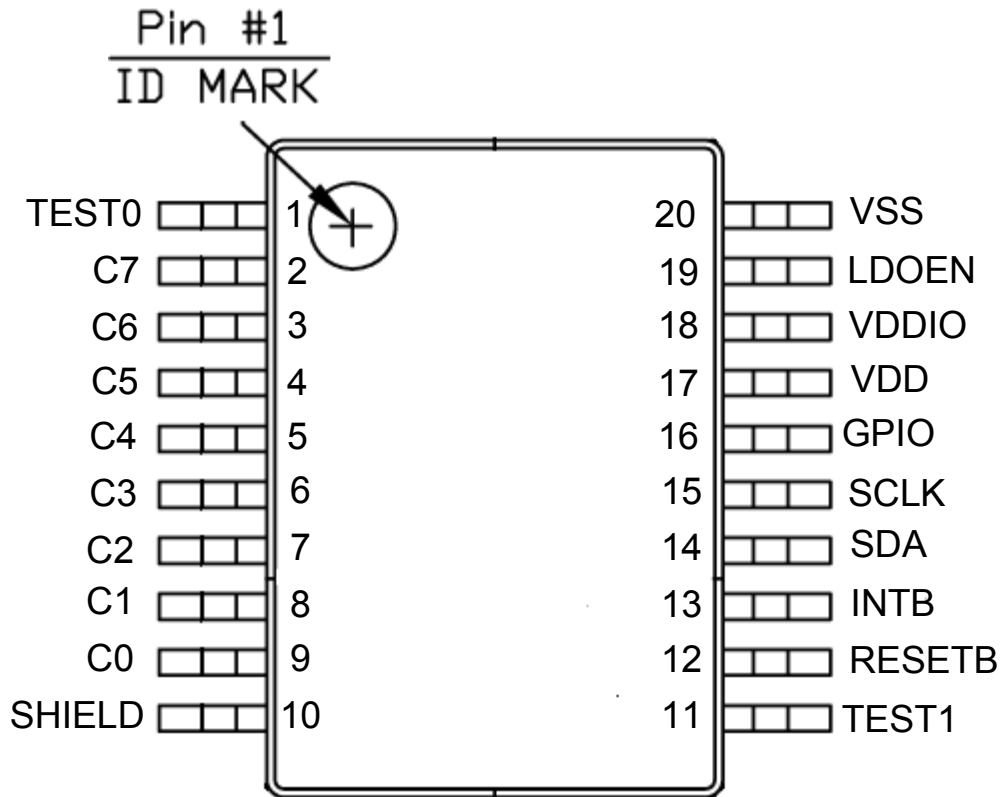

PIN LIST and FUNCTIONAL DESCRIPTIONS

Pin Name	Functional Description
Cx	Dedicated Capacitance Sensor Input
VDD	Touch Sensor Supply Voltage (1.8V nominal, LDO Disabled)
VSS	Touch Sensor Ground
LDOEN	LDO Enable ("0" = LDO Disable, 1.8V applied directly to VDD pin) ("1" = LDO Enable, Supply Voltage Applied to VDDIO)
VDDIO	Touch Sensor Supply Voltage (>1.95V, LDO Enabled) and/or Serial I/F Operating Voltage
SDA	I ² C Data I/O
SCLK	I ² C Clock Input
GPIO	General Purpose Input Output
INTB	Interrupt Output (CMOS Output)
RESETB	Hardware Reset pin for device (Active low)
SHIELD	CDC Shield. Connect to external shield/plane to reduce stray capacitance.
TEST0	Test pin must be connected to ground
TEST1	Test pin must be connected to ground
N.C.	No Connect (must be left floating)

FUNCTIONAL BLOCK DIAGRAM

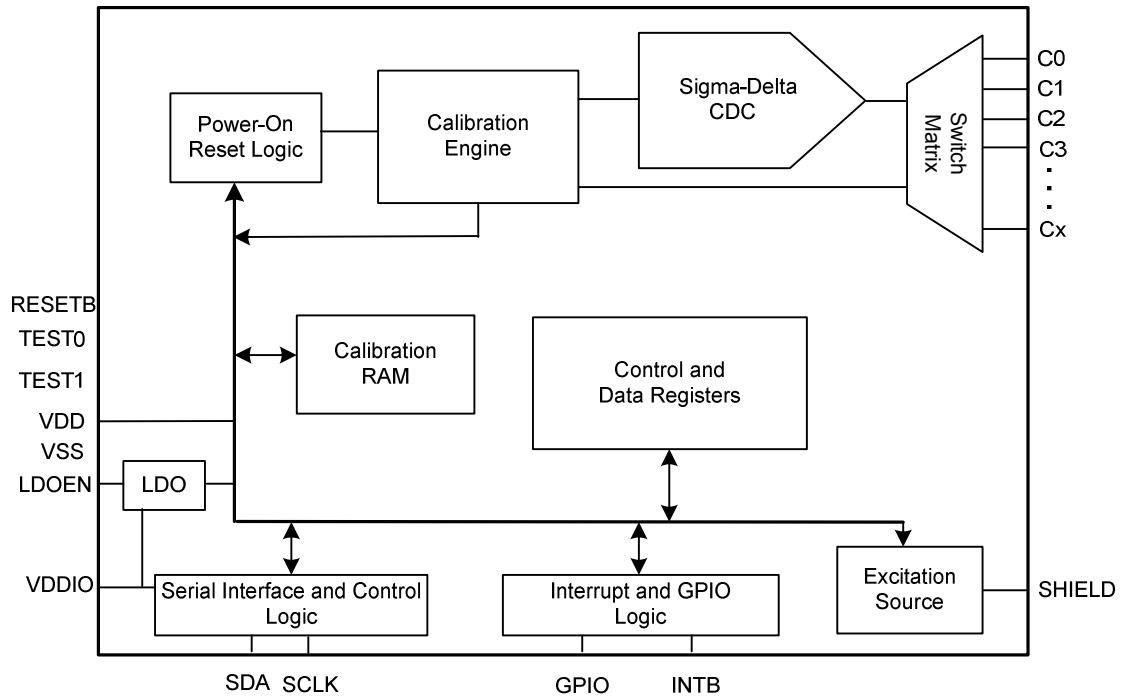

Figure 6: LDS6200 Family Functional Block Diagram

THEORY OF OPERATION

The LDS6200 PureTouch[®] Family of capacitive touch controllers feature a highly-accurate capacitance-to-digital converter (CDC) for touch button, slider, and scroll applications. Capacitive sensing is accomplished using a sigma-delta converter capable of converting a sensor input signal into a digital output that is compared against a touch/no-touch threshold value to determine if a touch has occurred. The button status and digitized capacitance values are stored in on-chip registers available to a host processor via the I²C or SMBus-compatible serial interface options.

On-chip self-calibration continuously takes environmental effects such as temperature, humidity, and dust into consideration to establish an accurate baseline capacitance for each sensor to ensure maximum responsiveness to true touch events.

The LDS6200 Family includes up to 8 sensor input pins, with a programmable switch matrix determining which sensor inputs are connected to the CDC at any given time. The sensor inputs may be connected to external capacitance sensors arranged as buttons, sliders, scroll wheels or other creatively arranged user inputs. Button, slider, and scroll inputs are natively supported using built in logic, with location and direction automatically calculated for slider and scroll inputs.

On-chip registers allow adjustment of the sampling (decimation) rate, threshold/sensitivity for each individual sensor, and hysteresis and debounce characteristics, enabling a very high degree of configurability in scan rate, button sensitivity and overall touch characteristics.

An interrupt output, INTB, is available to notify the host when a touch event has occurred. A GPIO is also available to act as an input to control the INTB output. The GPIO pin may also be configured as an output low or output high pin to turn on and off an external LED.

Due to its ultra-low touch sensor power consumption of <125uW^{***} (typ), the LDS6200 Family may be operated continuously at full power to achieve the most responsive touch characteristics and best possible user experience. In this mode, touch sensor detection occurs continuously at very low power levels, eliminating the need for sleep periods between detection cycles that result in touch latency and an inconsistent user experience.

The LDS6200 Family operates with supply voltages ranging from 1.8V to 5.5V. Available package options vary by device and include two thin form factor 3mm x 3mm 16-pin and 3mm x 3mm 20-pin TQFN packages, and 3.9mm x 9.9mm 16-pin or 7.5mm x 12.8mm 20-pin SOIC packages.

^{***} 1.8V, excluding VDDIO current, which varies with VDDIO voltage, I/F type, and communication frequency

OPERATING MODES

The LDS6200 Family may be programmed to operate in three different modes.

In full power mode, touch detection occurs continuously, without delays between detection cycles. This mode is utilized when the touch inputs need to be fully active and always responsive to touch inputs. Due to its ultra-low touch sensor power consumption of <math><125\mu\text{W}</math>***, the LDS6200 Family may be operated continuously in full power mode even when battery life is of premium importance.

The device may also be put into a configurable low power mode for situations where a small inserted delay (typically less than 0.3s) between the first touch and touch reporting is acceptable. This optional low power mode can cut power by more than half.

Lastly, the device can be put into Shutdown mode, which disables touch sensing and lowers power consumption to ~1 μW (typical). Only the serial interface bus is active during Shutdown mode to receive any commands (such as exit from Shutdown mode).

Two methods of device reset are provided. Software Reset (writing any value to register 0x001) executes a soft reset of the device by initiating a new calibration cycle and resetting the state machine, including the Interrupt Status Register. Previously configured control registers, however, are not affected by a Software Reset, so no reconfiguration or re-initialization need occur.

Hardware Reset (setting RESETB low or writing any value to register 0x000) resets the state machine and all previously configured registers, requiring a re-initialization by the host to set configuration registers to their proper state.

Both Software and Hardware Reset take ~0.5-1s in the typical case to return the device to its fully functioning state. The actual time depends upon the number of active sensors requiring calibration and the relative sensor values. Where start-up time is especially important, fine-tuning of certain configuration registers is possible to expedite initial calibration. Please contact your IDT representative if start-up time optimization is required.

POWER-UP/INITIALIZATION SEQUENCE

The power up and initialization sequence involves the following flow:

Power-Up → Cold Reset Command → Initialize Configuration Registers → Software Reset Command

Initialization of the configuration registers is required to define the functionality of each channel, set touch sensitivity levels, and generally specify the desired configuration of the highly flexible LDS6200 Family touch controller. The Cold Reset and Software Reset Commands are required to ensure consistency of operation before and after the initialization process occurs.

AUTOMATIC CALIBRATION MODE

The LDS6200 Family integrates on-chip sensor calibration to compensate for uncontrollable environmental factors such as moisture and temperature changes. Without such compensation, the baseline “no-touch” value may drift over time, affecting the ability of the device to measure valid touch events. The calibration algorithm is executed after every conversion cycle, ensuring that even rapidly changing ambient conditions are well compensated.

*** 1.8V, excluding VDDIO current, which varies with VDDIO voltage, I/F type, and communication frequency

LOW POWER MODE CONFIGURATION

Low power mode may be utilized when extremely low power consumption is desired and a small amount of added delay/latency is acceptable. By setting Bit 1 of the Power Configuration Register (0x002) to “1”, low power mode is activated and the touch controller will alternate between full power sensing and a lower power sleep mode where power is conserved but touches are not sensed.

The amount of power saved is a function of the sleep period time inserted between full power scan cycles. The full power scan cycle time is equal to ~2ms x the number of active sensors. For example, 10 active sensors would result in a full power scan cycle time of ~20ms.

The amount of sleep time inserted occurs in 1ms increments by setting the Sleep Configuration Register (0x056) to the # of milliseconds desired for the sleep cycle. For example, a setting of 50 (decimal) will insert 50ms of sleep time, lowering the average power consumption compared to a continuous full power state. The longer the sleep period added, the lower the average power consumption will be, with the trade-off of longer potential latency between touch and touch recognition

The following tables show that low power mode current consumption is a function of not only the inserted sleep period, but also the number of active sensors. It should also be noted that the greatest power savings benefit is realized when adding the first ~250ms of sleep period (less when fewer sensors are active). When adding sleep periods longer than ~250ms, the resulting reduction in current is relatively minor. Accordingly, the system designer should take into consideration the # of active sensors and incremental power savings when deciding upon the sleep period, as it may not be materially beneficial to insert longer sleep periods.

In an example scenario of 8 active sensors, current consumption may be lowered to ~24uA*** (>60% current reduction) when introducing a relatively brief 100ms of sleep. Adding an additional 150ms of sleep (for 250ms total) only saves an additional 4uA.

Once a touch is detected, the touch controller will remain in full power mode, maximizing touch responsiveness, until a certain amount of time passes without a touch event. The Sleep Wait Register (0x003) specifies the time the controller will remain in full power mode (waiting for a new touch) before going back to low power mode.

Current vs Sleep Period & Active Sensors (50/100/250ms)

# Active Sensors	Sleep Period (ms)	Current Consumption (uA)	Sleep Period (ms)	Current Consumption (uA)	Sleep Period (ms)	Current Consumption (uA)
1	50	20	100	18	250	18
2	50	22	100	19	250	18
3	50	23	100	20	250	18
4	50	25	100	21	250	19
5	50	26	100	22	250	19
6	50	27	100	23	250	20
7	50	29	100	24	250	20
8	50	30	100	24	250	20

Current vs Sleep Period & Active Sensors (500/1000ms)

# Active Sensors	Sleep Period (ms)	Current Consumption (uA)	Sleep Period (ms)	Current Consumption (uA)
1	500	17	1000	17
2	500	18	1000	17
3	500	18	1000	17
4	500	18	1000	17
5	500	18	1000	18
6	500	18	1000	18
7	500	18	1000	18
8	500	19	1000	18

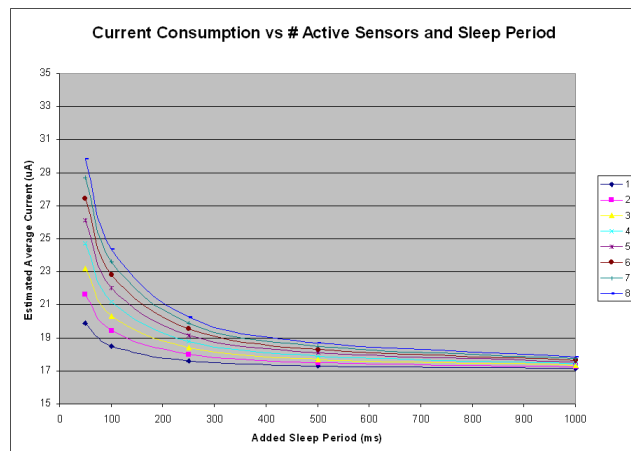

*** 1.8V, excluding VDDIO current, which varies with VDDIO voltage, I/F type, and communication frequency

SELECTIVE TOUCH MODES

The LDS6200 Family touch controller is capable of detecting up to 8 simultaneous touches (on LDS6204). However, in certain situations, the application may want to only allow one or two valid touch events at any given time.

To accommodate such application requirements and avoid inadvertent touches, the LDS6200 Family has four selective touch modes: **Strongest Absolute Touch** and **Two Strongest Absolute Touches**. As the names indicate, Strongest Absolute Touch mode only registers the single strongest touch event at any given time, as judged by the absolute capacitance value, as long as it is above the touch threshold value. Similarly, Two Strongest Absolute Touches mode only registers the two strongest touch events at any given time, as judged by absolute capacitance values.

New to the LDS6200 Family are **Strongest Relative Touch** and **Strongest Two Relative Touches**. Instead of judging strongest touch by absolute capacitance value, the judgments are made looking at the delta between measured capacitance value and touch threshold value. The largest *delta* (defined as “capacitance value minus threshold level” for each sensor) is considered the strongest relative touch (and largest two deltas considered the two strongest relative touches). Where sensor sizes (and therefore the resulting capacitance values resulting from a touch) are significantly different, these two new modes can help achieve the desired effect of registering the most definitive/intended touch or touches.

Bits 8 and 9 of the “Touch Configuration Register” (0x040) control whether selective touch is active (Bit 8/9 = 1/0 for Strongest Touch, 0/1 for Two Strongest Touches). The device defaults to the unrestricted or “all touch” mode (Bits 8 and 9 = 0) upon power up.

To select between Absolute and Relative touch preference modes, a single bit RELATIVE_EN (bit 15 of Register 0x075) is utilized, with bit status “0” used for the Absolute modes and bit status “1” used for the Relative Modes.

To avoid frequent toggling of the strongest touch with two touches of comparable strength, an additional (optional) time criteria may be added that requires a new and stronger touch to remain stronger for a certain period of time before replacing the current strongest touch. The REPLACEMENT_TIME bits (0-15 of Strongest Touch Replacement Time Configuration Register 0x028) are used for this purpose. This option is available in Strongest Touch

mode (Absolute or Relative) only and is not applicable to Two Strongest Touch modes.

RECALIBRATION FOR “STUCK” TOUCHES

The LDS6200 Family of products enables an automatic forced recalibration when a touch persists beyond a certain length of time. This optional feature enables recalibration in the case that some material remains on the sensor resulting in a continuous, but unintended, touch signal.

The Stuck Touch Recalibration Register (0x053) sets the time limit for a continuous touch before a recalibration is forced. When a recalibration occurs, all active sensors are recalibrated. **To ensure that a lengthy, but real, touch does not result in recalibration, it is generally advisable to set the timer limit for stuck touch recalibration to be well above the expected duration for a valid touch.** The actual time limit is a function of the # of configured active sensors. For more detail on how to set a specific stuck touch time limit, please refer to the Detailed Register Document for the particular device being used.

PROXIMITY SENSOR

The LDS6200 Family has built in proximity sensor capability. Each touch sensor can be enabled to act as a proximity sensor by using register 0x039 bits 0-7, but only one touch sensor can be used as a proximity sensor. Register 0x046 bits 0-7 are used to check the status of the proximity sensor. Increasing bits 10 – 15 of register 0x039 will increase the sensitivity of the proximity channel. Sensitivity should be adjusted for each application to achieve solid reliability. **For more information please see Application Note 62xxAN1.**

TOUCH EVENT DURING POWER ON

When the device is first powered on the device will automatically calibrate to adjust to external conditions such as ambient temperature, humidity and smudges. To indicate a touch event during power on, bit 0 of register 0x038 will need to be enabled by setting to ‘1’. In order to be able to identify a touch event upon power up SELC values must be predefined for each active touch sensor using registers 0x030 – 0x037. By setting a predefined SELC value a touch event can still be recognized on power up without concern of not having the touch event acknowledged since it has been calibrated into the signal. **For more information please see Application Note 62xxAN1.**

TOUCH OPTIMIZATION

DEBOUNCE

The debounce feature enables a time criteria to be set as an “acceptance” criteria for a touch being recognized as valid. Because capacitive touch inputs frequently involve rigid overlays, there is no compression or “give” associated with a touch. As a result, a finger may very lightly “bounce” for a period of time, resulting in a fluctuating capacitive effect on the capacitive sensor. If the fluctuation results in capacitance values varying above and below the touch threshold level, multiple touches may be erroneously reported to the host processor.

By setting a time criteria required for the capacitive signal to remain above the threshold value, this type of inadvertent multiple touch event may be eliminated. The Debounce Registers (0x020 to 0x027) are used for this purpose. Bits 0-8 set the # of **consecutive** scan cycles that the capacitive signal must remain above the touch threshold value before a touch is reported to the host. The LDS62xx family allows each channel to set its debounce criteria independently of the other channels.

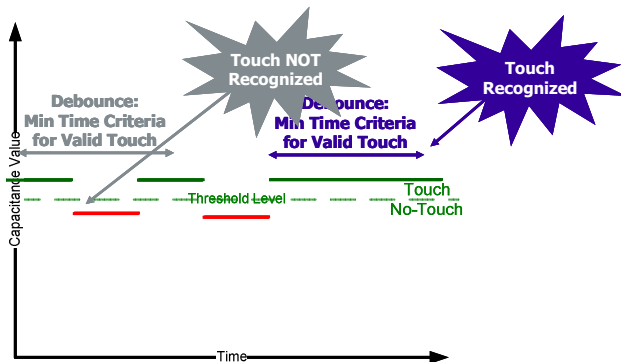

The diagram above shows an example of fluctuating capacitive signal and the debounce time that eliminates multiple touch reporting.

HYSTERESIS

Hysteresis is another method of ensuring touch stability. The hysteresis feature enables a “buffer region” to be established within which the capacitive value of an established touch may vary and still be recognized as a continuous touch. Hysteresis Configuration Register 0x075 (bits 0-5) sets the amount of capacitance variation (referenced from the Touch Threshold level depicted in the diagram below) that may be tolerated before the current touch is reported as being removed from the sensor.

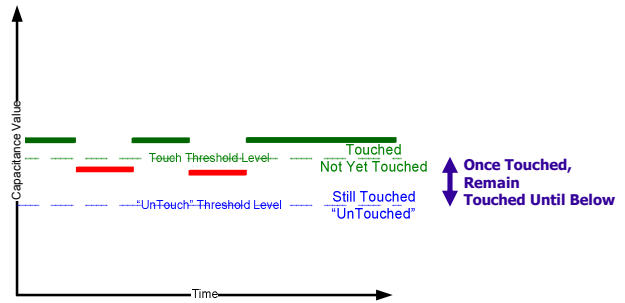

The diagram above shows a typical example of hysteresis, which allows a certain amount of capacitance variation to occur without multiple touch events being reported to the host. In the above diagram, the buffer region is defined by the area below the Touch Threshold Level and above the “UnTouch” Threshold level. This size of this region is effectively specified by programming the amount of capacitance variation allowed via the Hysteresis Configuration Register value.

With hysteresis, the weaker capacitive signal depicted by the two intermittent lines falling below the original touch threshold are now considered a continuation of the original touch since they remain above the UnTouch threshold level.

CAPACITANCE-TO-DIGITAL CONVERSION

The LDS6200 Family capacitance-to-digital converter (CDC) utilizes a sigma-delta design for capacitive sensing. Up to 8 sensor inputs are available to be connected through a switch matrix to the CDC.

The nominal decimation (oversampling) rate is 1024, which designates the number of samples acquired per sensor input for each scan cycle. The decimation process averages multiple samples from the CDC to arrive at one optimized result. The process of averaging multiple samples reduces the effect of spurious noise that can adversely affect touch detection.

The decimation rate may be programmed from the nominal value of 1024 to alternate rates of 128, 256, 512, or 2048. Since the update time per sensor is directly affected by the selected decimation rate, care should be taken to assure that the proper balance is achieved between system performance and touch update rates. In the majority of cases, the default decimation rate is optimal.

The conversion time per sensor input depends upon the programmed decimation rate and the possible options are shown in the table below:

Conversion Time/Input vs Decimation Rate (ms)

	Decimation Rate (d)			
	128	256	512	1024
Conversion Time	0.256	0.512	1.024	2.048

Table 1: Conversion Time (in ms) per Input vs Decimation Rate

The update rate (time between sequential scan cycles) is the product of the single output CDC conversion rate above multiplied by the number of active sensors. For the highest channel LDS6200 offering, if all 8 sensor inputs are utilized, the maximum possible update rate would be ~16ms.

CDC SEQUENCER

Based upon the status of the sensor input configuration above, the on-board sequencer will proceed to sample all sensor-connected inputs and convert the capacitance measurements to digital capacitive value referenced off a baseline value. Those configured as floating will not be connected to the CDC for conversion.

The number of sensor inputs required for different input types will depend upon the nature of input type. A simple button input that registers only a touch/no-touch situation (“0D”) requires only one input. Position-variable inputs with more than just an on/off designation (“1D” inputs such as sliders and scroll wheels) require more than one input, with the required number dependant upon the desired resolution. For example, a coarse scroll wheel may be implemented with only 4 sensor inputs, while a higher resolution version might be implemented with 10 inputs. The LDS6200 Family of products includes built-in 2x interpolation, meaning 2 times the number of touch positions as physical elements can be achieved (2 times # of elements minus 1 in case of sliders). The location ID and direction are available via status registers.

Figures 11 and 12 below show connection examples of both a button/slider combination and a scroll wheel implementation.

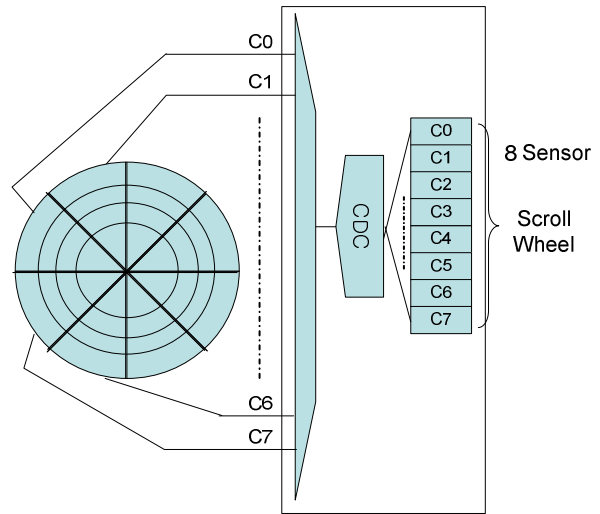

Figure 8: Scroll Wheel Connection Example

More detail on the configuration and usage of the built-in slider/scroll functionality will be available **Application Note 61xxAN1: “LDS61xx Enhanced Functionality Usage and Configuration”**.

SIMPLE RETRIEVAL OF TOUCH RESULTS: BUTTONS

The Interrupt Status Registers (0x043) contains the Interrupt status of every sensor input. When the relative magnitude of touch is not important and only touch or no-touch status is required, the Interrupt Status Register is sufficient for determining touch status of buttons.

The INTB pin is designed to drive low when either a valid touch or touch-termination (“untouch”) event occurs. In this way, INTB provides notification to the host processor that a touch-relevant event has occurred and the Interrupt Status Registers have been updated. By reading the Interrupt Status Registers and determining which sensor input interrupt bit is high, the system may determine which sensor was touched or untouched. (Note: The polarity of the INTB status pin may be configured at power up to invert to drive high when a touch or touch-termination event occurs).

The act of reading the Interrupt Status Register resets the INTB pin back to the high state. When the next touch-relevant event occurs, the process is repeated, with the host processor being notified by INTB driving low and subsequently reading the Interrupt Status Registers to determine which sensor inputs were touched or “untouched”.

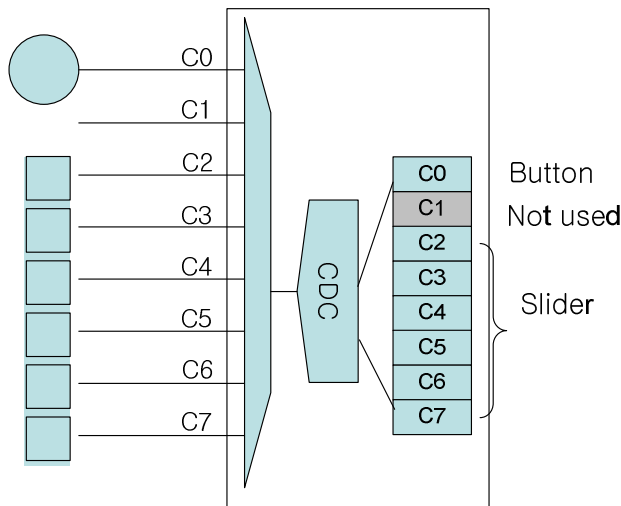

Figure 7: Button/Slider Connection Example

For “0D” or simple “on/off” (touch/untouch) inputs like buttons, the results of the Interrupt Status Register are sufficient to take action based on which touch button was activated.

TOUCH RESULTS: SLIDERS AND SCROLL

Position-variable or “1D” inputs with more than an on/off status require the host processor to read back the conversion status results to properly interpret touch location.

The LDS6200 Family offers built-in support for slider and scroll wheels, enabling the user to assign which sensor channels are utilized in slider or scroll input types. Slider/Scroll Configuration register 0x074 allows up to 8 channels (C0-C7) to be assigned as slider/scroll wheel elements. A separate slider/scroll interrupt bit is available, as well as a direction bit and 5-bit location ID register, register 0x045 bits 0-4, to directly read the current location being touched as well as the direction of movement. Two times interpolation is available to generate two times (two times minus one for sliders) the number of reported touch positions as actual touch elements to support higher resolution requirements.

For more information on configuring slider and scroll wheel setup and interpreting the results registers, please see the Application Note 61xxAN1: “LDS61xx Enhanced Functionality Usage and Configuration”.

Interpolation to achieve higher than 2x resolution enhancement is possible by using host-side algorithms to read the digital capacitance values and interpolate beyond the 2x level. The degree of interpolation achievable is a function of the sensor size, shape, and overlay thickness. Contact your local IDT contact for more information on >2x interpolated slider and scroll implementations.

OUTPUTS

GPIO OUTPUT

The GPIO pin may be disabled, configured as an input to control the INTB output (details on usage of GPIO as an input follow on page 38), or configured as either a low or high output. The “GPIO Configuration Register” (0x009) bits [1:0] are used for this purpose. The default state for GPIO is the output low state.

Use of the GPIO as an output can be used to turn on and off an LED if used with as the gate control of an external transistor which supplies the LED drive current.

INTERRUPT (INTB)

The INTB output notifies the host processor of an interrupt event. Interrupt events are classified into two categories: a sensor touch or untouch interrupt or a GPIO input generated interrupt.

By default, the INTB pin is configured as an active-low CMOS output, with no pull-up resistor necessary. When an interrupt event occurs, the LDS6200 Family pulls the INTB pin low to signal the host processor that a touch-relevant event has occurred.

Once the interrupt signal is triggered, the host processor may read the Interrupt Status Registers (0x043) to determine which type of interrupt has occurred (Bit 15 of 0x043 for GPIO input generated interrupt, other bits for touch generated interrupts). In the case of a touch or untouch event, a touch (finger down) will result in a “1” in the associated sensor register bit, while an untouch (finger up) will result in a “0”.

The Interrupt Status Registers and the INTB pin itself are reset once the host completes a read operation, enabling the next interrupt event to be sensed and communicated.

Touch and Untouch Interrupts

As mentioned in the above section, two interrupt events will be registered once a touch occurs: the first when contact is made with the capacitive sensor (finger down or “touch”), and again when contact is terminated (finger up or “untouch”). The figure below illustrates this.

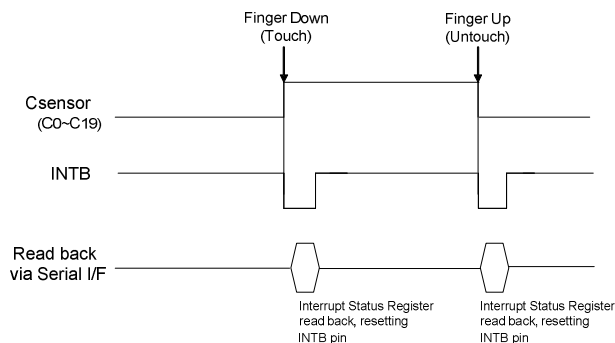

Figure 9: Sensor Activation Interrupt Example

The second interrupt notifies the host that the touch stimulus is no longer in contact with the sensor.

In order for the second interrupt to be properly differentiated from the first, the host should read back the Interrupt Status Registers when INTB is first pulled low to enable the INTB pin to return to its high state and be re-triggered when the untouch event occurs.

SHIELD

In the default device configuration, the SHIELD pin outputs the identical excitation waveform as that used on the actively read sensor input. In this configuration, SHIELD may effectively be utilized to reduce stray capacitance to ground that has the potential to affect the capacitance-to-digital conversion process.

By shielding both a) the connection traces between sensor array and LDS6200 Family sensor inputs and b) the shield plane around the sensor array elements themselves, stray capacitance is significantly reduced. Interactions between adjacent connection traces and between closely spaced sensor array elements are also reduced and longer distances between sensor array and LDS6200 Family may be supported while still achieving a high level of touch performance.

Please refer to AN5: Preliminary Use of SHIELD application note for more guidance on use of the SHIELD pin.

GPIO AS INPUT TO INTERRUPT SIGNAL

The GPIO pin may also be configured as an input to control the interrupt output INTB by programming the bits [1:0] in the “GPIO Configuration Register” (0x009) to [0,1]. When using GPIO as an input, INTB can be triggered on a low level, high level, falling edge, rising edge, or on both falling and rising edges of the GPIO pin. The GPIO Input Configuration bits (bits [4:2] of register 0x009) determine which stimuli type will trigger INTB. Figures 14-18 illustrate the various types of input triggers.

The GPIO status bit in the second Interrupt Status Register (Bit 15 of register 0x043) indicates that the GPIO trigger condition occurred. After a host reads this status register, the GPIO status bit and INTB signal are cleared (assuming the original triggering condition is no longer present) and no touch events are otherwise causing INTB to remain low.

Register 0x009 Bits [4:2]	Input Stimuli Type
000	Not used (Default)
001	Low level trigger
010	High level trigger
011/100	Not used
101	Falling edge trigger
110	Rising edge trigger
111	Both edge trigger

Table 3: GPIO Interrupt Configuration

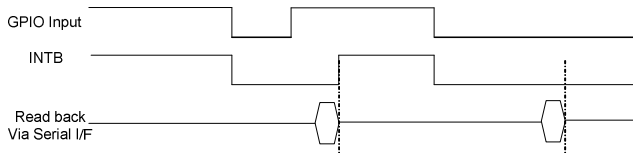

Figure 10: GPIO Low Level Trigger (GPIO Input Cfg = "001")

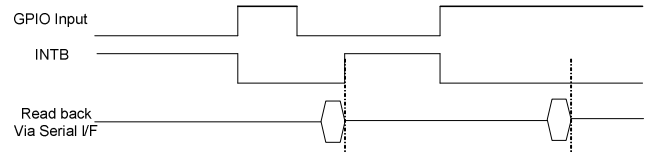

Figure 11: GPIO High Level Trigger (GPIO Input Cfg = "010")

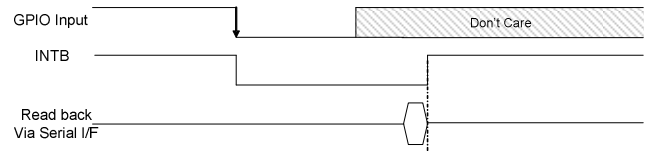

Figure 12: GPIO Falling Edge Trigger (GPIO Input Cfg = "101")

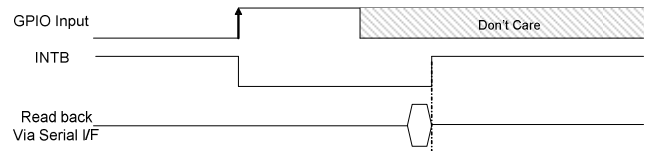

Figure 13: GPIO Rising Edge Trigger (GPIO Input Cfg = "110")

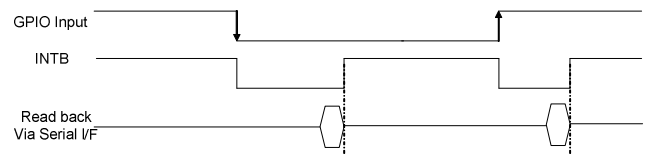

Figure 14: GPIO Both (Falling/Rising) Edge Trigger (GPIO Input Cfg = "111")

LDS6200 Family



PACKAGE DRAWING AND DIMENSIONS

16-PIN SOIC, 3.9mm x 9.9mm, 1.27mm PITCH

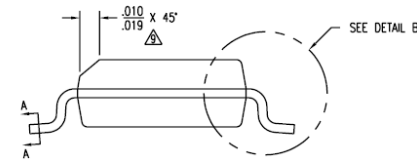
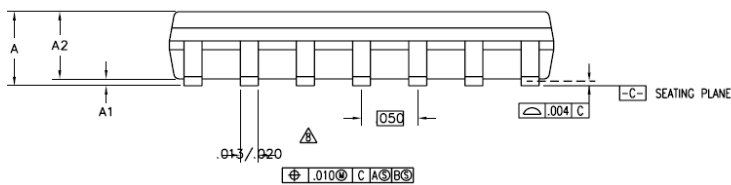
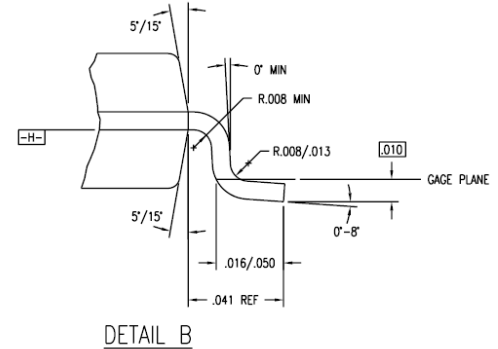
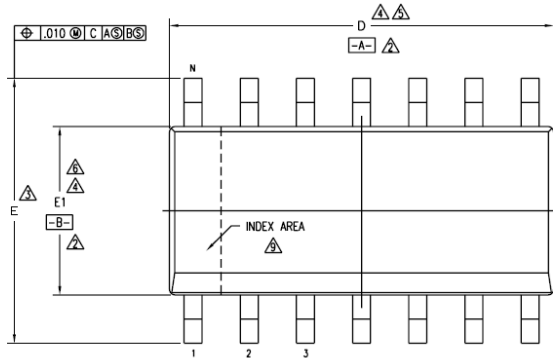

SYMBOL	JEDEC VARIATION			NOTE
	AC			
	MIN	NOM	MAX	
A	.053	.064	.068	
A1	.004	.006	.010	
A2	.055	.058	.061	11
D	.386	.391	.393	4,5
E	.230	.236	.244	3
E1	.150	.155	.157	4,6
N	16			

Measurement in Millimeters				
	MIN	NOM	MAX	Note
A	1.346	1.626	1.727	
A1	0.102	0.152	0.254	
A2	1.397	1.473	1.549	11
D	9.804	9.931	9.982	4, 5
E	5.842	5.994	6.198	3
E1	3.810	3.937	3.988	4, 6
N	16			

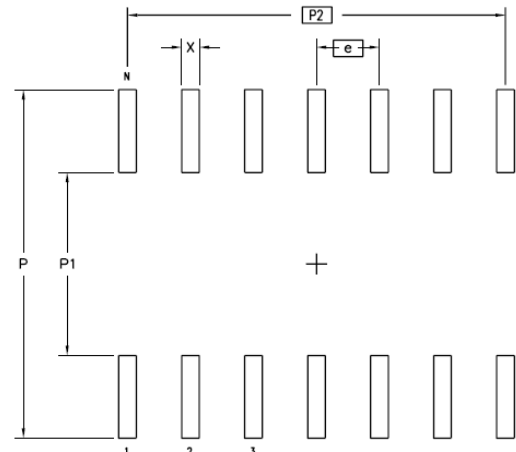

	MIN	MAX
P	.274	.282
P1	.142	.150
P2	.350 BSC	
X	.015	.024
e	.050 BSC	
N	16	

Measurement in Millimeters		
	MIN	MAX
P	6.960	7.163
P1	3.607	3.810
P2	8.89 BSC	
X	0.381	0.610
e	1.27 BSC	
N	16	

NOTES:

- ALL DIMENSIONING AND TOLERANCING CONFORM TO ANSI Y14.5M-1982
- DATUMS [-A-] AND [-B-] TO BE DETERMINED AT DATUM PLANE [-H-]
- DIMENSION E TO BE DETERMINED AT SEATING PLANE [-C-]
- DIMENSIONS D AND E1 ARE TO BE DETERMINED AT DATUM PLANE [-H-]
- DIMENSION D DOES NOT INCLUDE MOLD FLASH, PROTRUSIONS OR GATE BURRS. MOLD FLASH, PROTRUSIONS AND GATE BURRS SHALL NOT EXCEED .006 PER SIDE
- DIMENSION E1 DOES NOT INCLUDE INTERLEAD FLASH OR PROTRUSIONS. INTERLEAD FLASH OR PROTRUSIONS SHALL NOT EXCEED .010 PER SIDE
- THESE DIMENSIONS APPLY TO THE FLAT SECTION OF THE LEAD BETWEEN .005 AND .010 FROM LEAD TIP
- LEAD WIDTH DIMENSION DOES NOT INCLUDE DAMBAR PROTRUSION. ALLOWABLE DAMBAR PROTRUSION IS .004 IN EXCESS OF THE LEAD WIDTH DIMENSION AT MAXIMUM MATERIAL CONDITION. DAMBAR CANNOT BE LOCATED ON THE LOWER RADIUS OR THE FOOT
- THE CHAMFER ON THE PACKAGE BODY IS OPTIONAL. IF IT IS NOT PRESENT, A VISUAL INDEX FEATURE MUST BE LOCATED WITHIN THE ZONE INDICATED
- ALL DIMENSIONS ARE IN INCHES
- THIS OUTLINE CONFORMS TO JEDEC PUBLICATION 95 REGISTRATION MS-012, VARIATION AA, AB & AC

LDS6200 Family



PACKAGE DRAWING AND DIMENSIONS

20-PIN TQFN, 3mm x 3mm, 0.4mm PITCH

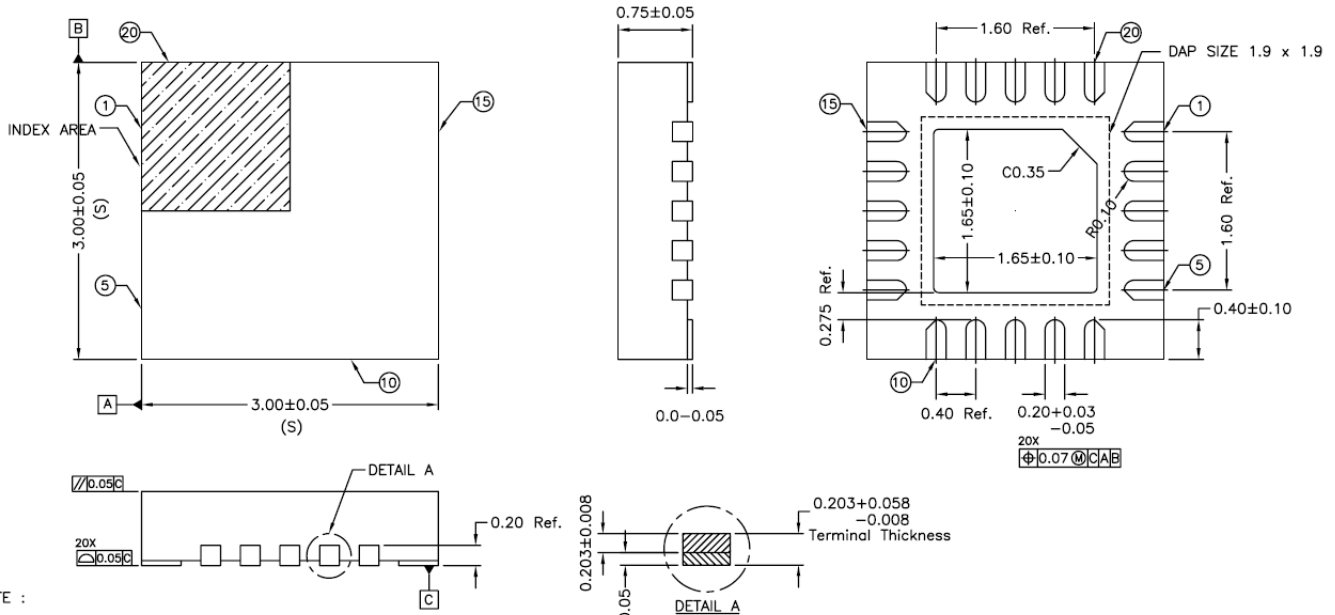

NOTE :

1. ALL DIMENSIONS ARE IN mm. ANGLES IN DEGREES.
2. COPLANARITY APPLIES TO THE EXPOSED PAD AS WELL AS THE TERMINALS. COPLANARITY SHALL NOT EXCEED 0.05 mm.
3. WARPAGE SHALL NOT EXCEED 0.05 mm.
4. PACKAGE LENGTH / PACKAGE WIDTH ARE CONSIDERED AS SPECIAL CHARACTERISTIC. (S)
5. REFER JEDEC MO-220.

PACKAGE DRAWING AND DIMENSIONS

LDS6200 Family



20-PIN SOIC, 7.5mm x 12.8mm, 1.27mm PITCH

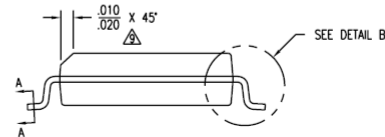
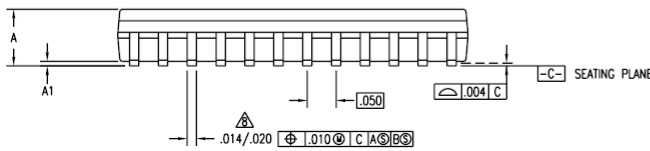
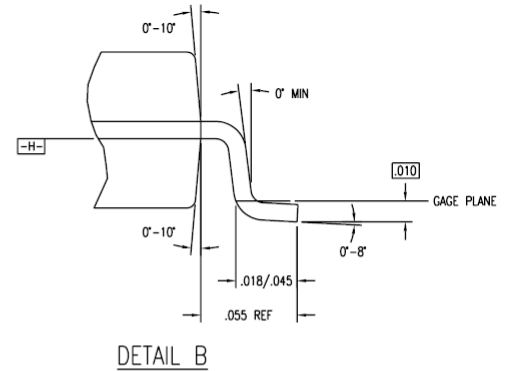
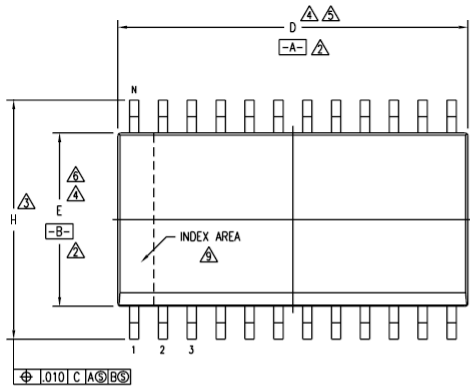

SYMBOL	JEDEC VARIATION			NOTE
	MIN	NOM	MAX	
A	.095	.100	.104	
A1	.004	.008	.012	
D	.497	.504	.511	4, 5
E	.292	.296	.299	4, 6
H	.400	.406	.419	3
N	20			

Measurement in Millimeters				
	MIN	NOM	MAX	Note
A	2.413	2.540	2.642	
A1	0.102	0.203	0.305	
D	12.624	12.802	12.979	4, 5
E	7.417	7.518	7.595	4, 6
H	10.160	10.312	10.643	3
N	20			

LAND PATTERN DIMENSIONS

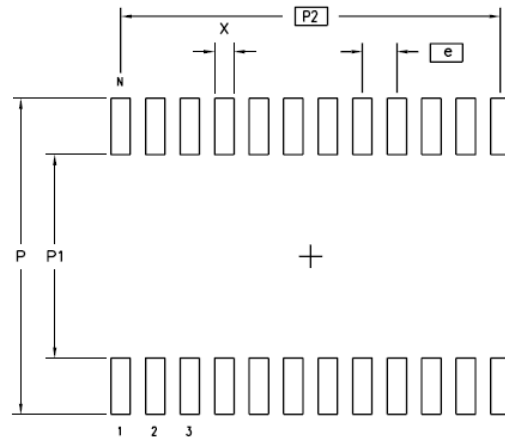

	MIN	MAX
P	.456	.464
P1	.292	.300
P2	.450 BSC	
X	.024	.032
e	.050 BSC	
N	20	

Measurement in Millimeters		
	MIN	MAX
P	11.582	11.786
P1	7.417	7.620
P2	11.43 BSC	
X	0.610	0.813
e	1.27 BSC	
N	20	

NOTES:

- ALL DIMENSIONING AND TOLERANCING CONFORM TO ANSI Y14.5M-1982
- DATUMS $-A-$ AND $-B-$ TO BE DETERMINED AT DATUM PLANE $-H-$
- DIMENSION H TO BE DETERMINED AT SEATING PLANE $-C-$
- DIMENSIONS D AND E ARE TO BE DETERMINED AT DATUM PLANE $-H-$
- DIMENSION D DOES NOT INCLUDE MOLD FLASH, PROTRUSIONS OR GATE BURRS. MOLD FLASH, PROTRUSIONS AND GATE BURRS SHALL NOT EXCEED .006 PER SIDE
- DIMENSION E DOES NOT INCLUDE INTERLEAD FLASH OR PROTRUSIONS. INTERLEAD FLASH OR PROTRUSIONS SHALL NOT EXCEED .010 PER SIDE
- THESE DIMENSIONS APPLY TO THE FLAT SECTION OF THE LEAD BETWEEN .005 AND .010 FROM LEAD TIP
- LEAD WIDTH DIMENSION DOES NOT INCLUDE DAMBAR PROTRUSION. ALLOWABLE DAMBAR PROTRUSION IS .004 IN EXCESS OF THE LEAD WIDTH DIMENSION AT MAXIMUM MATERIAL CONDITION. DAMBAR CANNOT BE LOCATED ON THE LOWER RADIUS OR THE FOOT
- THE CHAMFER ON THE PACKAGE BODY IS OPTIONAL. IF IT IS NOT PRESENT, A VISUAL INDEX FEATURE MUST BE LOCATED WITHIN THE ZONE INDICATED
- ALL DIMENSIONS ARE IN INCHES
- THIS OUTLINE CONFORMS TO JEDEC PUBLICATION 95 REGISTRATION MS-013, VARIATION AA, AB, AC, AD & AE

LDS6200 Family



ORDERING INFORMATION

Part Number*	Package	Package Marking
LDS6201NTGI8	TQFN-16 3mm x 3mm ⁽¹⁾	NTG
LDS6201DCGI8	SOIC-16 3.9mm X 9.9mm ⁽¹⁾	DCG
LDS6202NTGI8	TQFN-16 3mm x 3mm ⁽¹⁾	NTG
LDS6202DCGI8	SOIC-16 3.9mm X 9.9mm ⁽¹⁾	DCG
LDS6203NTGI8	TQFN-20 3mm x 3mm ⁽¹⁾	NTG
LDS6203SOGI8	SOIC-20 7.5mm X 12.8mm ⁽¹⁾	SOG
LDS6204NTGI8	TQFN-20 3mm x 3mm ⁽¹⁾	NTG
LDS6204SOGI8	SOIC-20 7.5mm X 12.8mm ⁽¹⁾	SOG

Notes (*Remove the "8" at the end of the part number for non-T/R option):

1. Matte-Tin Plated Finish (RoHS-compliant)
2. Quantity per reel is 2500 for TQFN package and 1500 for SOIC package

EXAMPLE OF ORDERING INFORMATION

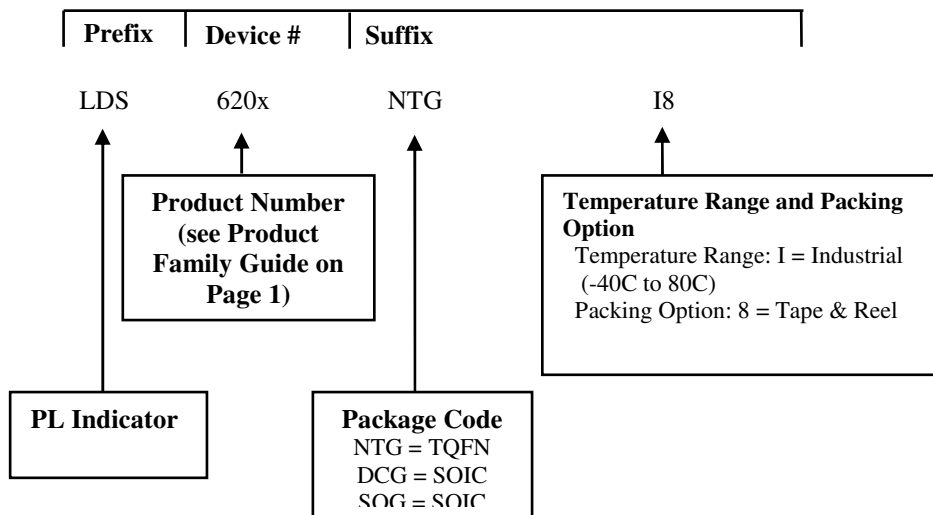

REVISION LOG

Date	Rev.	Reason
01/13/10	0.0	Initial Draft
04/09/10	0.1	Block diagram correction
05/06/10	0.2	Figure 11 and 12 update
06/25/10	0.3	Removed SSOP package and included SOIC package
11/10/10	0.4	Updated pinout diagrams to indicate TEST0 and TEST1 pins. Clarify connection requirements for TEST0 and TEST1 pins.
6/1/11	0.5	Updated 16ld TQFN package dimensions on page 30. Updated I2C read timing diagram

DISCLAIMER Integrated Device Technology , Inc. (IDT) and its subsidiaries reserve the right to modify the products and/or specifications described herein at any time and at IDT's sole discretion. All information in this document, including descriptions of product features and performance, is subject to change without notice. Performance specifications and the operating parameters of the described products are determined in the independent state and are not guaranteed to perform the same way when installed in customer products. The information contained herein is provided without representation or warranty of any kind, whether express or implied, including, but not limited to, the suitability of IDT's products for any particular purpose, an implied warranty of merchantability, or non-infringement of the intellectual property rights of others. This document is presented only as a guide and does not convey any license under intellectual property rights of IDT or any third parties.

IDT's products are not intended for use in life support systems or similar devices where the failure or malfunction of an IDT product can be reasonably expected to significantly affect the health or safety of users. Anyone using an IDT product in such a manner does so at their own risk, absent an express, written agreement by IDT.

Integrated Device Technology, IDT and the IDT logo are registered trademarks of IDT. Other trademarks and service marks used herein, including protected names, logos and designs, are the property of IDT or their respective third party owners.



6024 Silver Creek Valley Road
San Jose, California 95138
<http://www.idt.com>

Document No: 6200 Family DS
Revision: 0.5
Issue date: 6/30/11

Looking for pricing, stock, or lifecycle information?

Click below to explore more details on WIN SOURCE:

-  [View LDS6202NTGI on WIN SOURCE](#)
-  [IDT, Integrated Device Technology Inc Information](#)

Optimize Your Supply Chain with WIN SOURCE Solutions

-  Global Sourcing Solution
-  Obsolete Management
-  Cost Control Management
-  Shortage Management
-  Alternative Solution
-  Excess Inventory Management