



**THE DATASHEET OF
MADRCC0007TR**



Features

- High Speed CMOS Technology
- Quad Channel
- Positive Voltage Control
- Low Power Dissipation
- Low Cost Plastic SOIC-16 Package
- 100% Matte Tin Plating over Copper
- Halogen-Free “Green” Mold Compound
- 260°C Reflow Compatible
- RoHS* Compliant Version of SWD-119

Description

The MADRCC0007 is a quad channel driver used to translate TTL control inputs into gate control voltages for GaAs FET microwave switches and attenuators. High speed analog CMOS technology is utilized to achieve low power dissipation at moderate to high speeds, encompassing most microwave switching applications. The output HIGH level is optionally 0 to +2.0V (relative to GND) to optimize the intermodulation products of the control devices at low frequencies.

Functional Schematic

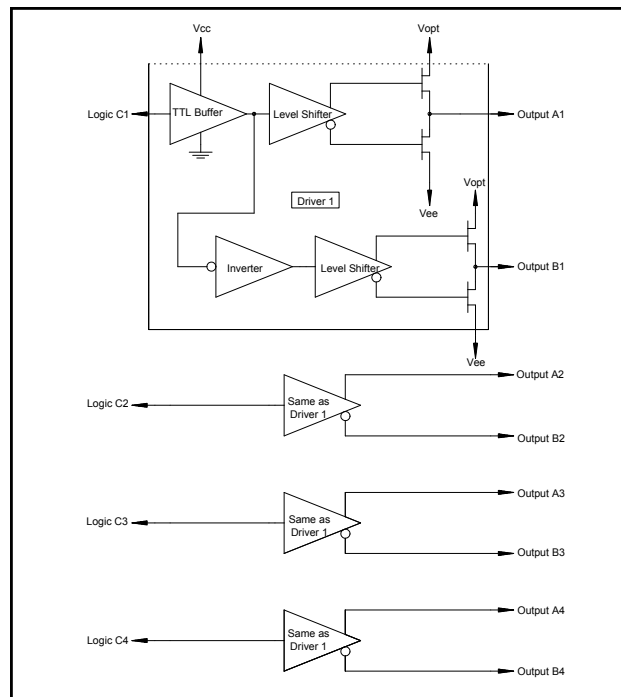

Pin Configuration

Pin No.	Function	Pin No.	Function
1	Vee	9	Output A1
2	Vcc	10	Output B1
3	C4	11	Output A2
4	C3	12	Output B2
5	C2	13	Output A3
6	C1	14	Output B3
7	Vopt	15	Output A4
8	Ground	16	Output B4

Ordering Information

Part Number	Package
MADRCC0007 PIN	Bulk Packaging
MADRCC0007TR	1000 piece reel

Note: Reference Application Note M513 for reel size information.

1 * Restrictions on Hazardous Substances, European Union Directive 2002/95/EC.

Guaranteed Operating Ranges

Symbol	Parameter ¹	Unit	Min.	Typ.	Max.
V_{CC}	Positive DC Supply Voltage	V	4.5	5.0	5.5
V_{EE}	Negative DC Supply Voltage	V	-8.5	-5.0	-4.5
V_{OPT} ²	Optional DC Output Supply Voltage	V	0	1.0	2.0
$V_{OPT}-V_{EE}$	Negative Supply Voltage Range	V	4.5	6.5	8.5
$V_{CC}-V_{EE}$	Positive to negative Supply Range	V	9.0	10.0	14.0
T_A	Operating Ambient temperature	°C	-40	+25	+85
I_{OH}	DC Output Current - High	mA	—	—	-1.0
I_{OL}	DC Output Current - Low	mA	—	—	1.0
T_{rise}, T_{fall}	Maximum Input Rise or Fall Time	nS	—	—	500

1. All voltages are relative to GND.

2. V_{OPT} is grounded for most applications. To improve the intermodulation performance and the 1 dB compression point of GaAs control devices at low frequencies, V_{OPT} can be increased to between 1.0 and 2.0V. The nonlinear characteristics of the GaAs control devices will approximate performance at 500 MHz. It should be noted that the control current that is on the GaAs MMICs will increase when positive controls are applied.

DC Characteristics over Guaranteed Operating Range

Symbol	Parameter	Test Conditions		Units	Min.	Typ.	Max.
V_{IH}	Input High Voltage	Guaranteed High Input Voltage		V	2.0	—	—
V_{IL}	Input Low Voltage	Guaranteed Low Input Voltage		V	—	—	0.8
V_{IH}	Output High Voltage	$I_{OH} = -1$ mA	$V_{EE} = \text{Max}$	V	$V_{OPT} - 0.1$	—	—
V_{OL}	Output Low Voltage	$I_{OL} = 1$ mA	$V_{EE} = \text{Max}$	V	—	—	$V_{EE} + 0.1$
I_{IN}	Input Leakage Current	$V_{IN} = V_{CC}$ or GND	$V_{EE} = \text{Min}$	μA	-1.0	0	1.0
I_{CC}	Quiescent Supply Current	$V_{CC} = \text{Max}$ $V_{OPT} = \text{Min}$ or Max	$V_{EE} = \text{Min}$ $V_{IN} = V_{CC}$ or GND	μA	—	250	400
ΔI_{CC}	Additional Supply Current, per TTL Input pin	$V_{CC} = \text{Max}$	$V_{IN} = V_{CC} - 2.1V$	mA	—	—	1.0

Handling Procedures

Please observe the following precautions to avoid damage:

Static Sensitivity

Silicon Integrated Circuits are sensitive to electrostatic discharge (ESD) and can be damaged by static electricity. Proper ESD control techniques should be used when handling these devices.

Truth Table

Input	Outputs	
	A	B
Logic "0"	V_{EE}	V_{OPT}
Logic "1"	V_{OPT}	V_{EE}

AC Characteristics Over Guaranteed Operating Range ³

Symbol	Parameter	-55 to +25°C	≤+85°C	≤+125°C	Unit
T _{PLH}	Propagation Delay	22	25	30	nS
T _{PHL}	Propagation Delay	22	25	30	nS
T _{TLH}	Output Rising Transition Time	9.0	9.0	9.0	nS
T _{THL}	Output Falling Transition Time	8.0	8.0	8.0	nS
T _{skew}	Delay Skew, Output A to Output B	4.0	4.0	4.0	nS
C _{IN}	Input Capacitance	10	10	10	pF
C _{PDC}	Power Dissipation Capacitance ⁴	10	10	10	pF
C _{PDE}	Power Dissipation Capacitance ⁴	140	140	140	pF

3. V_{CC} = 4.5V, V_{OPT} - V_{EE} = min or max, V_{OPT} = 0V, C_L = 25 pF, Trise, Tfall = 6nS. These conditions represent the worst case for slow delays.

4. Total Power Dissipation is calculated by the following formula: $PD = V_{CC}^2 f_{C_{PDC}} + (V_{OPT} - V_{EE})^2 f_{C_{PDE}}$

Absolute Maximum Ratings ⁵

Symbol	Parameter	Min	Max	Unit
V _{CC}	Positive DC Supply Voltage	-0.5	7.0	V
V _{EE}	Negative DC Supply Voltage	-9.0	0.5	V
V _{OPT}	Optional DC Output Supply Voltage	-0.5	V _{CC} +0.5	V
V _{OPT} -V _{EE}	Output to Negative Supply Voltage Range	-0.5	9.0	V
V _{CC} -V _{EE}	Positive to Negative Supply Voltage Range	-0.5	14.5	V
V _I	DC Input Voltage	-0.5	V _{CC} +0.5	V
I _I	DC Input Current	-25	25	mA
V _O	DC Output Voltage	V _{EE} -0.5	V _{OPT} +0.5	V
P _D ⁶	Power Dissipation in Still Air	—	500	mW
T _{STG}	Storage Temperature	-65	150	°C

Switching Waveforms

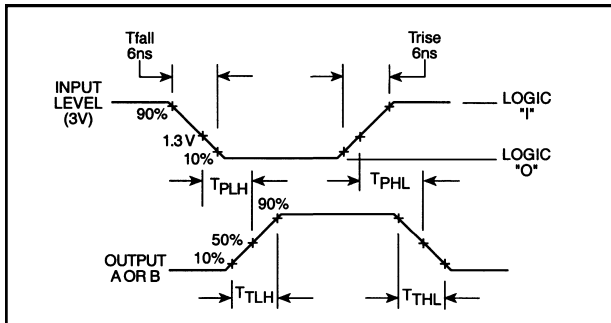

5. All voltages are referenced to GND. All inputs and outputs incorporate latch-up protection structures.

6. Derate -7 mW/°C from 65°C to 85°C.

Lead-Free, SOIC-16†

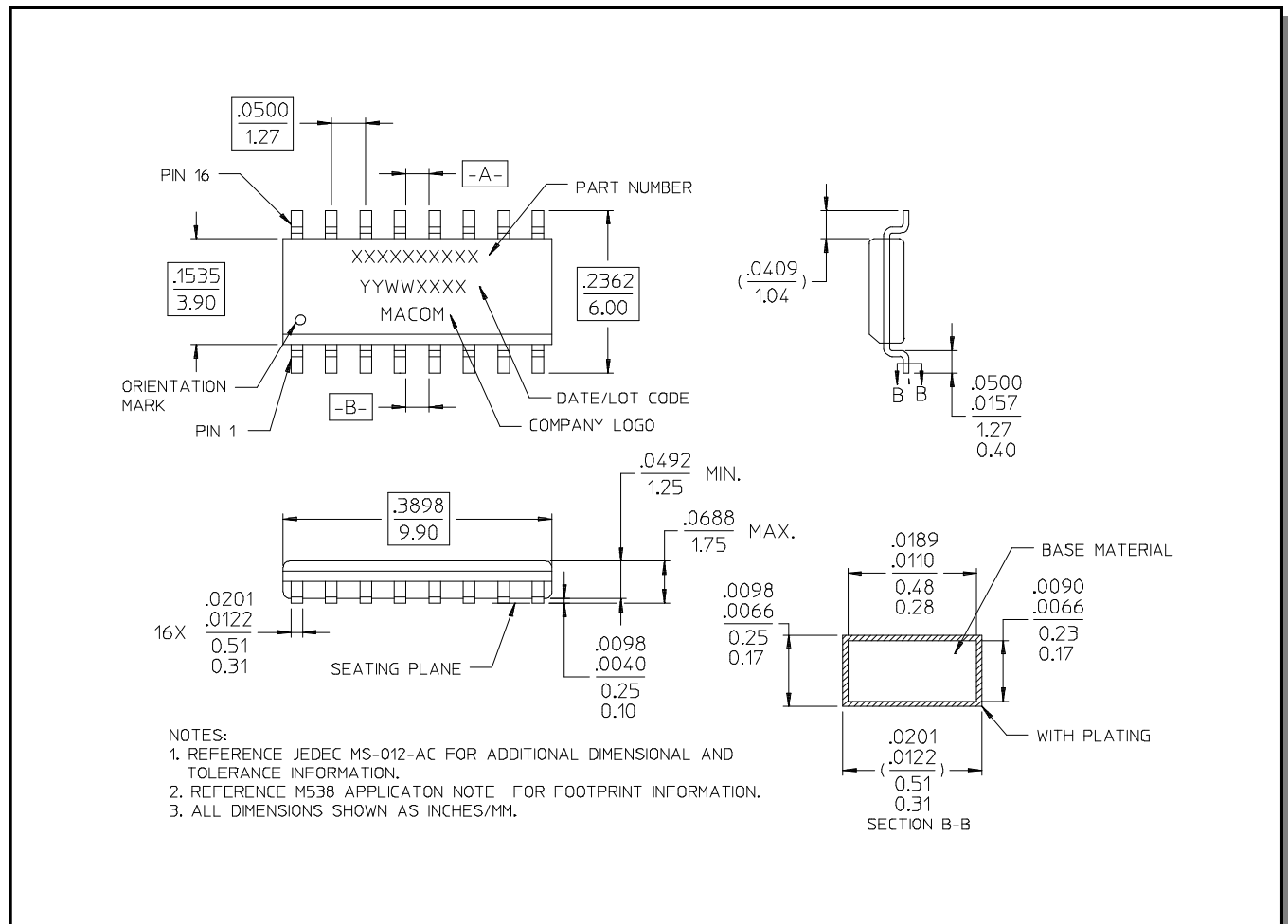

† Reference Application Note M538 for lead-free solder reflow recommendations.

M/A-COM Technology Solutions Inc. All rights reserved.

Information in this document is provided in connection with M/A-COM Technology Solutions Inc ("MACOM") products. These materials are provided by MACOM as a service to its customers and may be used for informational purposes only. Except as provided in MACOM's Terms and Conditions of Sale for such products or in any separate agreement related to this document, MACOM assumes no liability whatsoever. MACOM assumes no responsibility for errors or omissions in these materials. MACOM may make changes to specifications and product descriptions at any time, without notice. MACOM makes no commitment to update the information and shall have no responsibility whatsoever for conflicts or incompatibilities arising from future changes to its specifications and product descriptions. No license, express or implied, by estoppel or otherwise, to any intellectual property rights is granted by this document.

THESE MATERIALS ARE PROVIDED "AS IS" WITHOUT WARRANTY OF ANY KIND, EITHER EXPRESS OR IMPLIED, RELATING TO SALE AND/OR USE OF MACOM PRODUCTS INCLUDING LIABILITY OR WARRANTIES RELATING TO FITNESS FOR A PARTICULAR PURPOSE, CONSEQUENTIAL OR INCIDENTAL DAMAGES, MERCHANTABILITY, OR INFRINGEMENT OF ANY PATENT, COPYRIGHT OR OTHER INTELLECTUAL PROPERTY RIGHT. MACOM FURTHER DOES NOT WARRANT THE ACCURACY OR COMPLETENESS OF THE INFORMATION, TEXT, GRAPHICS OR OTHER ITEMS CONTAINED WITHIN THESE MATERIALS. MACOM SHALL NOT BE LIABLE FOR ANY SPECIAL, INDIRECT, INCIDENTAL, OR CONSEQUENTIAL DAMAGES, INCLUDING WITHOUT LIMITATION, LOST REVENUES OR LOST PROFITS, WHICH MAY RESULT FROM THE USE OF THESE MATERIALS.

MACOM products are not intended for use in medical, lifesaving or life sustaining applications. MACOM customers using or selling MACOM products for use in such applications do so at their own risk and agree to fully indemnify MACOM for any damages resulting from such improper use or sale.

Looking for pricing, stock, or lifecycle information?

Click below to explore more details on WIN SOURCE:

- ⊖ [View MADRCC0007TR on WIN SOURCE](#)
- ⊖ [M/A-Com Technology Solutions Information](#)

Optimize Your Supply Chain with WIN SOURCE Solutions

- ✓ Global Sourcing Solution
- ✓ Obsolete Management
- ✓ Cost Control Management
- ✓ Shortage Management
- ✓ Alternative Solution
- ✓ Excess Inventory Management