6 Channel Capacitive Touch Sensor with 2 LED Drivers

General Description

The CAP1126, which incorporates RightTouch® technology, is a multiple channel Capacitive Touch sensor with multiple power LED drivers. It contains six (6) individual capacitive touch sensor inputs with programmable sensitivity for use in touch sensor applications. Each sensor input automatically recalibrates to compensate for gradual environmental changes.

The CAP1126 also contains two (2) LED drivers that offer full-on / off, variable rate blinking, dimness controls, and breathing. Each of the LED drivers may be linked to one of the sensor inputs to be actuated when a touch is detected. As well, each LED driver may be individually controlled via a host controller.

The CAP1126 includes Multiple Pattern Touch recognition that allows the user to select a specific set of buttons to be touched simultaneously. If this pattern is detected, then a status bit is set and an interrupt generated.

Additionally, the CAP1126 includes circuitry and support for enhanced sensor proximity detection.

The CAP1126 offers multiple power states operating at low quiescent currents. In the Standby state of operation, one or more capacitive touch sensor inputs are active and all LEDs may be used. If a touch is detected, it will wake the system using the WAKE/SPI_MOSI pin.

Deep Sleep is the lowest power state available, drawing 5uA (typical) of current. In this state, no sensor inputs are active. Driving the WAKE/SPI_MOSI pin or communications will wake the device.

Applications

- Desktop and Notebook PCs
- LCD Monitors
- Consumer Electronics
- Appliances

Features

- Six (6) Capacitive Touch Sensor Inputs
 - Programmable sensitivity
 - Automatic recalibration
 - Individual thresholds for each button
- Proximity Detection
- Multiple Button Pattern Detection
- Calibrates for Parasitic Capacitance
- Analog Filtering for System Noise Sources
- Press and Hold feature for Volume-like Applications
- Multiple Communication Interfaces
 - SMBus / I²C compliant interface
 - SPI communications
 - Pin selectable communications protocol and multiple slave addresses (SMBus / I²C only)
- Low Power Operation
 - 5uA quiescent current in Deep Sleep
 - 50uA quiescent current in Standby (1 sensor input monitored)
 - Samples one or more channels in Standby
- Two (2) LED Driver Outputs
 - Open Drain or Push-Pull
 - Programmable blink, breathe, and dimness controls
 - Can be linked to Capacitive Touch Sensor inputs
- Dedicated Wake output flags touches in low power state
- System RESET pin
- Available in 16-pin 4mm x 4mm RoHS compliant QFN package

TO OUR VALUED CUSTOMERS

It is our intention to provide our valued customers with the best documentation possible to ensure successful use of your Microchip products. To this end, we will continue to improve our publications to better suit your needs. Our publications will be refined and enhanced as new volumes and updates are introduced.

If you have any questions or comments regarding this publication, please contact the Marketing Communications Department via E-mail at docerrors@microchip.com. We welcome your feedback.

Most Current Data Sheet

To obtain the most up-to-date version of this data sheet, please register at our Worldwide Web site at:

<http://www.microchip.com>

You can determine the version of a data sheet by examining its literature number found on the bottom outside corner of any page. The last character of the literature number is the version number, (e.g., DS30000000A is version A of document DS30000000).

Errata

An errata sheet, describing minor operational differences from the data sheet and recommended workarounds, may exist for current devices. As device/documentation issues become known to us, we will publish an errata sheet. The errata will specify the revision of silicon and revision of document to which it applies.

To determine if an errata sheet exists for a particular device, please check with one of the following:

- Microchip's Worldwide Web site; <http://www.microchip.com>
- Your local Microchip sales office (see last page)

When contacting a sales office, please specify which device, revision of silicon and data sheet (include -literature number) you are using.

Customer Notification System

Register on our web site at www.microchip.com to receive the most current information on all of our products.

CAP1126

Table of Contents

1.0 Block Diagram	4
2.0 Pin Description	5
3.0 Electrical Specifications	9
4.0 Communications	12
5.0 General Description	23
6.0 Register Description	29
7.0 Package Information	67
Appendix A: Device Delta	72
Appendix B: Data Sheet Revision History	74
The Microchip Web Site	76
Customer Change Notification Service	76
Customer Support	76
Product Identification System	77

CAP1126

1.0 BLOCK DIAGRAM

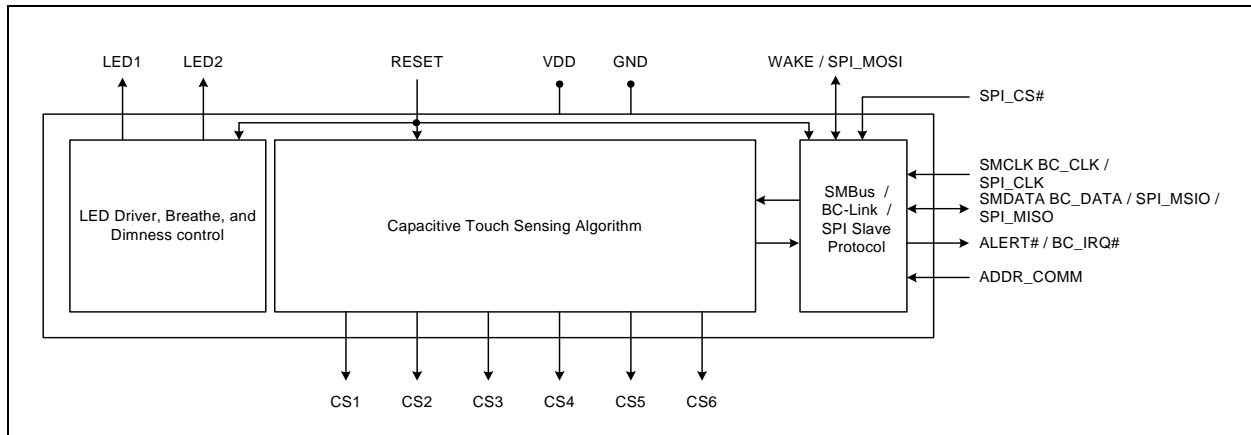

CAP1126

2.0 PIN DESCRIPTION

FIGURE 2-1: CAP1126 Pin Diagram (16-Pin QFN)

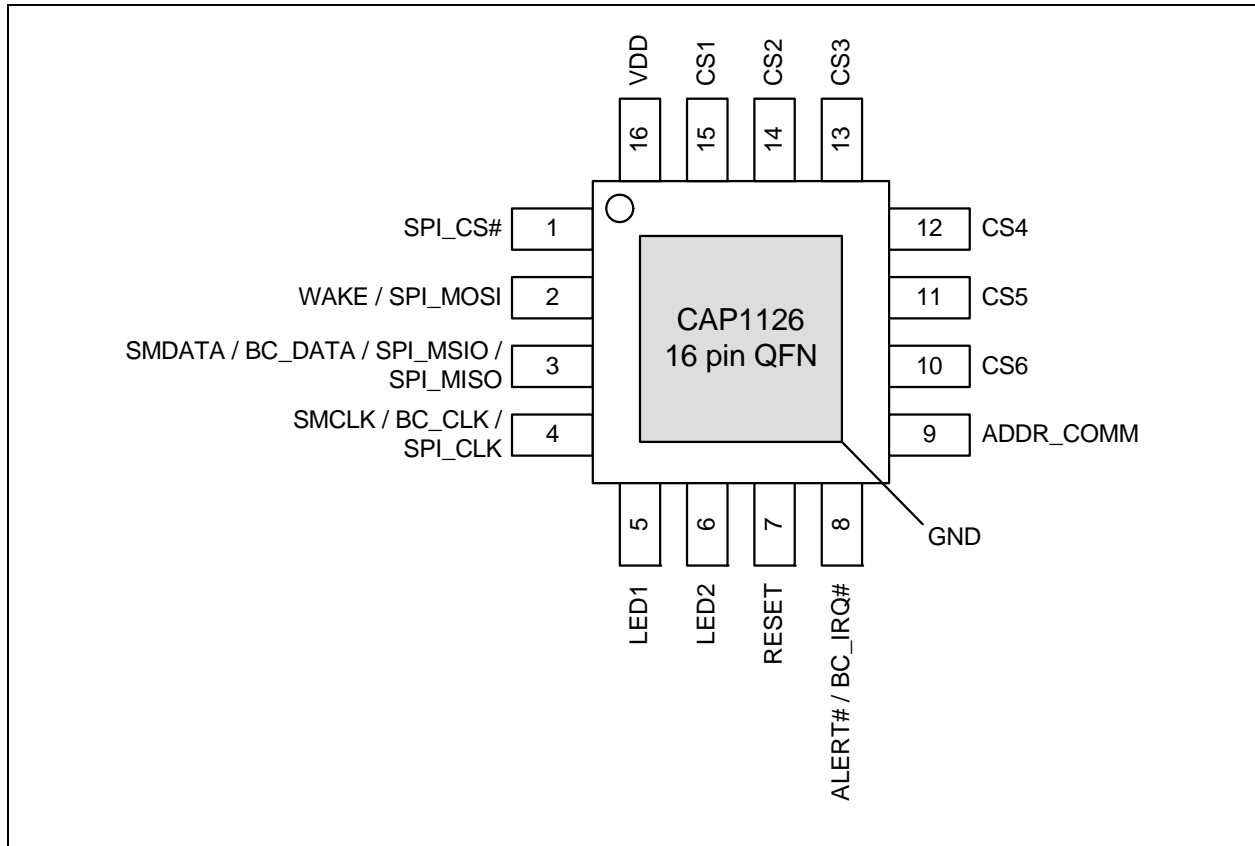

TABLE 2-1: PIN DESCRIPTION FOR CAP1126

Pin Number	Pin Name	Pin Function	Pin Type	Unused Connection
1	SPI_CS#	Active low chip-select for SPI bus	DI (5V)	Connect to Ground
2	WAKE / SPI_MOSI	WAKE - Active high wake / interrupt output Standby power state - requires pull-down resistor	DO	Pull-down Resistor
		WAKE - Active high wake input - requires pull-down resistor Deep Sleep power state	DI	
		SPI_MOSI - SPI Master-Out-Slave-In port when used in normal mode	DI (5V)	Connect to Ground

CAP1126

TABLE 2-1: PIN DESCRIPTION FOR CAP1126 (CONTINUED)

Pin Number	Pin Name	Pin Function	Pin Type	Unused Connection
3	SMDATA / SPI_MSIO / SPI_MISO	SMDATA - Bi-directional, open-drain SMBus data - requires pull-up resistor	DIOD (5V)	n/a
		SPI_MSIO - SPI Master-Slave-In-Out bidirectional port when used in bi-directional mode	DIO	
		SPI_MISO - SPI Master-In-Slave-Out port when used in normal mode	DO	
4	SMCLK / SPI_CLK	SMCLK - SMBus clock input - requires pull-up resistor	DI (5V)	n/a
		SPI_CLK - SPI clock input	DI (5V)	
5	LED1	Open drain LED 1 driver (default)	OD (5V)	Connect to Ground
		Push-pull LED 1 driver	DO	leave open or connect to Ground
6	LED2	Open drain LED 2 driver (default)	OD (5V)	Connect to Ground
		Push-pull LED 2 driver	DO	leave open or connect to Ground
7	RESET	Active high soft reset for system - resets all registers to default values. If not used, connect to ground.	DI (5V)	Connect to Ground
8	ALERT#	ALERT# - Active low alert / interrupt output for SMBus alert or SPI interrupt	OD (5V)	Connect to Ground
		ALERT# - Active high push-pull alert / interrupt output for SMBus alert or SPI interrupt	DO	leave open
9	ADDR_COMM	Address / communications select pin - pull-down resistor determines address / communications mechanism	AI	n/a
10	CS6	Capacitive Touch Sensor Input 6	AIO	Connect to Ground
11	CS5	Capacitive Touch Sensor Input 5	AIO	Connect to Ground
12	CS4	Capacitive Touch Sensor Input 4	AIO	Connect to Ground
13	CS3	Capacitive Touch Sensor Input 3	AIO	Connect to Ground
14	CS2	Capacitive Touch Sensor Input 2	AIO	Connect to Ground
15	CS1	Capacitive Touch Sensor Input 1	AIO	Connect to Ground
16	VDD	Positive Power supply	Power	n/a

CAP1126

TABLE 2-1: PIN DESCRIPTION FOR CAP1126 (CONTINUED)

Pin Number	Pin Name	Pin Function	Pin Type	Unused Connection
Bottom Pad	GND	Ground	Power	n/a

APPLICATION NOTE: When the ALERT# pin is configured as an active low output, it will be open drain. When it is configured as an active high output, it will be push-pull.

APPLICATION NOTE: For the 5V tolerant pins that have a pull-up resistor, the pull-up voltage must not exceed 3.6V when the CAP1126 is unpowered.

APPLICATION NOTE: The SPI_CS# pin should be grounded when SMBus, or I²C, communications are used. The pin types are described in [Table 2-2](#). All pins labeled with (5V) are 5V tolerant.

TABLE 2-2: PIN TYPES

Pin Type	Description
Power	This pin is used to supply power or ground to the device.
DI	Digital Input - This pin is used as a digital input. This pin is 5V tolerant.
AIO	Analog Input / Output - This pin is used as an I/O for analog signals.
DIOD	Digital Input / Open Drain Output - This pin is used as a digital I/O. When it is used as an output, it is open drain and requires a pull-up resistor. This pin is 5V tolerant.
OD	Open Drain Digital Output - This pin is used as a digital output. It is open drain and requires a pull-up resistor. This pin is 5V tolerant.
DO	Push-pull Digital Output - This pin is used as a digital output and can sink and source current.
DIO	Push-pull Digital Input / Output - This pin is used as an I/O for digital signals.

CAP1126

3.0 ELECTRICAL SPECIFICATIONS

TABLE 3-1: ABSOLUTE MAXIMUM RATINGS

Voltage on 5V tolerant pins (V_{5VT_PIN})	-0.3 to 5.5	V
Voltage on 5V tolerant pins ($ V_{5VT_PIN} - V_{DD} $) Note 3-2	0 to 3.6	V
Voltage on VDD pin	-0.3 to 4	V
Voltage on any other pin to GND	-0.3 to $V_{DD} + 0.3$	V
Package Power Dissipation up to $T_A = 85^\circ\text{C}$ for 16 pin QFN (see Note 3-3)	0.9	W
Junction to Ambient (θ_{JA}) (see Note 3-4)	58	$^\circ\text{C/W}$
Operating Ambient Temperature Range	-40 to 125	$^\circ\text{C}$
Storage Temperature Range	-55 to 150	$^\circ\text{C}$
ESD Rating, All Pins, HBM	8000	V

- Note 3-1** Stresses above those listed could cause permanent damage to the device. This is a stress rating only and functional operation of the device at any other condition above those indicated in the operation sections of this specification is not implied.
- Note 3-2** For the 5V tolerant pins that have a pull-up resistor, the voltage difference between V_{5VT_PIN} and V_{DD} must never exceed 3.6V.
- Note 3-3** The Package Power Dissipation specification assumes a recommended thermal via design consisting of a 3x3 matrix of 0.3mm (12mil) vias at 1.0mm pitch connected to the ground plane with a 2.1mm x 2.1mm thermal landing.
- Note 3-4** Junction to Ambient (θ_{JA}) is dependent on the design of the thermal vias. Without thermal vias and a thermal landing, the θ_{JA} is approximately 60°C/W including localized PCB temperature increase.

CAP1126

TABLE 3-2: ELECTRICAL SPECIFICATIONS

V _{DD} = 3V to 3.6V, T _A = 0°C to 85°C, all typical values at T _A = 27°C unless otherwise noted.						
Characteristic	Symbol	Min	Typ	Max	Unit	Conditions
DC Power						
Supply Voltage	V _{DD}	3.0	3.3	3.6	V	
Supply Current	I _{STBY}		120	170	uA	Standby state active 1 sensor input monitored No LEDs active Default conditions (8 avg, 70ms cycle time)
	I _{STBY}		50		uA	Standby state active 1 sensor input monitored No LEDs active 1 avg, 140ms cycle time,
	I _{DSLEEP}		5	15	uA	Deep Sleep state active LEDs at 100% or 0% Duty Cycle No communications T _A < 40°C 3.135 < V _{DD} < 3.465V
	I _{DD}		500	600	uA	Capacitive Sensing Active No LEDs active
Capacitive Touch Sensor Inputs						
Maximum Base Capacitance	C _{BASE}		50		pF	Pad untouched
Minimum Detectable Capacitive Shift	ΔC _{TOUCH}	20			fF	Pad touched - default conditions (1 avg, 35ms cycle time, 1x sensitivity)
Recommended Cap Shift	ΔC _{TOUCH}	0.1		2	pF	Pad touched - Not tested
Power Supply Rejection	PSR		±3	±10	counts / V	Untouched Current Counts Base Capacitance 5pF - 50pF Maximum sensitivity Negative Delta Counts disabled All other parameters default
Timing						
RESET Pin Delay	t _{RST_DLY}	10			ms	
Time to communications ready	t _{COMM_DLY}			15	ms	
Time to first conversion ready	t _{CONV_DLY}		170	200	ms	
LED Drivers						
Duty Cycle	DUTY _{LED}	0		100	%	Programmable
Drive Frequency	f _{LED}		2		kHz	
Sinking Current	I _{SINK}			24	mA	V _{OL} = 0.4
Sourcing Current	I _{SOURCE}			24	mA	V _{OH} = V _{DD} - 0.4
Leakage Current	I _{LEAK}			±5	uA	powered or unpowered T _A < 85°C pull-up voltage ≤ 3.6V if unpowered
I/O Pins						
Output Low Voltage	V _{OL}			0.4	V	I _{SINK_IO} = 8mA
Output High Voltage	V _{OH}	V _{DD} - 0.4			V	I _{SOURCE_IO} = 8mA

CAP1126

TABLE 3-2: ELECTRICAL SPECIFICATIONS (CONTINUED)

V _{DD} = 3V to 3.6V, T _A = 0°C to 85°C, all typical values at T _A = 27°C unless otherwise noted.						
Characteristic	Symbol	Min	Typ	Max	Unit	Conditions
Input High Voltage	V _{IH}	2.0			V	
Input Low Voltage	V _{IL}			0.8	V	
Leakage Current	I _{LEAK}			±5	uA	powered or unpowered T _A < 85°C pull-up voltage ≤ 3.6V if unpowered
RESET Pin Release to conversion ready	t _{RESET}		170	200	ms	
SMBus Timing						
Input Capacitance	C _{IN}		5		pF	
Clock Frequency	f _{SMB}	10		400	kHz	
Spike Suppression	t _{SP}			50	ns	
Bus Free Time Stop to Start	t _{BUF}	1.3			us	
Start Setup Time	t _{SU:STA}	0.6			us	
Start Hold Time	t _{HD:STA}	0.6			us	
Stop Setup Time	t _{SU:STO}	0.6			us	
Data Hold Time	t _{HD:DAT}	0			us	When transmitting to the master
Data Hold Time	t _{HD:DAT}	0.3			us	When receiving from the master
Data Setup Time	t _{SU:DAT}	0.6			us	
Clock Low Period	t _{LOW}	1.3			us	
Clock High Period	t _{HIGH}	0.6			us	
Clock / Data Fall Time	t _{FALL}			300	ns	Min = 20+0.1C _{LOAD} ns
Clock / Data Rise Time	t _{RISE}			300	ns	Min = 20+0.1C _{LOAD} ns
Capacitive Load	C _{LOAD}			400	pF	per bus line
SPI Timing						
Clock Period	t _P	250			ns	
Clock Low Period	t _{LOW}	0.4 x t _P		0.6 x t _P	ns	
Clock High Period	t _{HIGH}	0.4 x t _P		0.6 x t _P	ns	
Clock Rise / Fall time	t _{RISE} / t _{FALL}			0.1 x t _P	ns	
Data Output Delay	t _{D:CLK}			10	ns	
Data Setup Time	t _{SU:DAT}	20			ns	
Data Hold Time	t _{HD:DAT}	20			ns	
SPI_CS# to SPI_CLK setup time	t _{SU:CS}	0			ns	
Wake Time	t _{WAKE}	10		20	us	SPI_CS# asserted to CLK assert

Note 3-5 The ALERT pin will not glitch high or low at power up if connected to VDD or another voltage.

Note 3-6 The SMCLK and SMDATA pins will not glitch low at power up if connected to VDD or another voltage.

CAP1126

4.0 COMMUNICATIONS

4.1 Communications

The CAP1126 communicates using the 2-wire SMBus or I²C bus, the 2-wire proprietary BC-Link, or the SPI bus. If the proprietary BC-Link protocol is required for your application, please contact your Microchip representative for ordering instructions. Regardless of communication mechanism, the device functionality remains unchanged. The communications mechanism as well as the SMBus (or I²C) slave address is determined by the resistor connected between the ADDR_COMM pin and ground as shown in [Table 4-1](#).

TABLE 4-1: ADDR_COMM PIN DECODE

Pull-Down Resistor (+/- 5%)	Protocol Used	SMBus Address
GND	SPI Communications using Normal 4-wire Protocol Used	n/a
56k	SPI Communications using Bi-Directional 3-wire Protocol Used	n/a
68k	Reserved	n/a
82k	SMBus / I ² C	0101_100(r/w)
100k	SMBus / I ² C	0101_011(r/w)
120k	SMBus / I ² C	0101_010(r/w)
150k	SMBus / I ² C	0101_001(r/w)
VDD	SMBus / I ² C	0101_000(r/w)

4.1.1 SMBUS (I²C) COMMUNICATIONS

When configured to communicate via the SMBus, the CAP1126 supports the following protocols: Send Byte, Receive Byte, Read Byte, Write Byte, Read Block, and Write Block. In addition, the device supports I²C formatting for block read and block write protocols.

APPLICATION NOTE: For SMBus/I²C communications, the SPI_CS# pin is not used and should be grounded; any data presented to this pin will be ignored.

See [Section 4.2](#) and [Section 4.3](#) for more information on the SMBus bus and protocols respectively.

4.1.2 SPI COMMUNICATIONS

When configured to communicate via the SPI bus, the CAP1126 supports both bi-directional 3-wire and normal 4-wire protocols and uses the SPI_CS# pin to enable communications.

APPLICATION NOTE: See [Section 4.5](#) and [Section 4.6](#) for more information on the SPI bus and protocols respectively. Upon power up, the CAP1126 will not respond to any communications for up to 15ms. After this time, full functionality is available.

4.2 System Management Bus

The CAP1126 communicates with a host controller, such as an SIO, through the SMBus. The SMBus is a two-wire serial communication protocol between a computer host and its peripheral devices. A detailed timing diagram is shown in [Figure 4-1](#). Stretching of the SMCLK signal is supported; however, the CAP1126 will not stretch the clock signal.

FIGURE 4-1: SMBus Timing Diagram

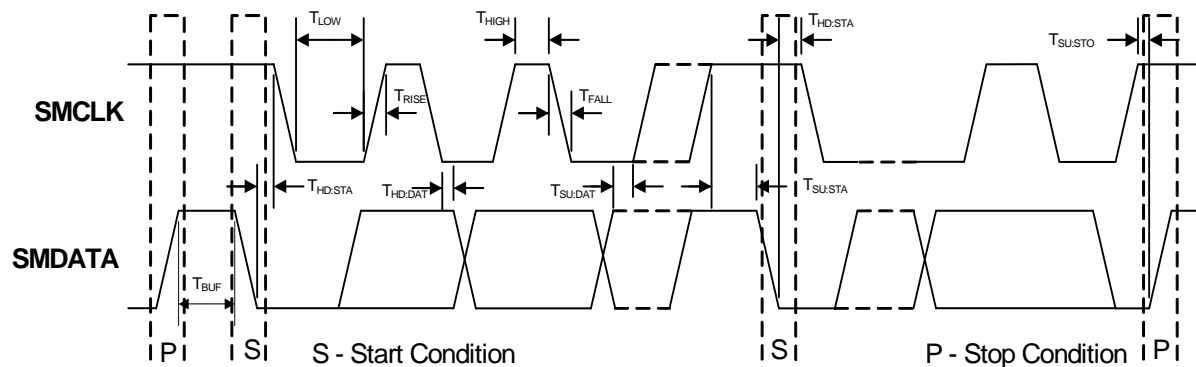

4.2.1 SMBUS START BIT

The SMBus Start bit is defined as a transition of the SMBus Data line from a logic '1' state to a logic '0' state while the SMBus Clock line is in a logic '1' state.

4.2.2 SMBUS ADDRESS AND RD / \overline{WR} BIT

The SMBus Address Byte consists of the 7-bit slave address followed by the RD / \overline{WR} indicator bit. If this RD / \overline{WR} bit is a logic '0', then the SMBus Host is writing data to the slave device. If this RD / \overline{WR} bit is a logic '1', then the SMBus Host is reading data from the slave device.

See [Table 4-1](#) for available SMBus addresses.

4.2.3 SMBUS DATA BYTES

All SMBus Data bytes are sent most significant bit first and composed of 8-bits of information.

4.2.4 SMBUS ACK AND NACK BITS

The SMBus slave will acknowledge all data bytes that it receives. This is done by the slave device pulling the SMBus Data line low after the 8th bit of each byte that is transmitted. This applies to both the Write Byte and Block Write protocols.

The Host will NACK (not acknowledge) the last data byte to be received from the slave by holding the SMBus data line high after the 8th data bit has been sent. For the Block Read protocol, the Host will ACK each data byte that it receives except the last data byte.

4.2.5 SMBUS STOP BIT

The SMBus Stop bit is defined as a transition of the SMBus Data line from a logic '0' state to a logic '1' state while the SMBus clock line is in a logic '1' state. When the CAP1126 detects an SMBus Stop bit and it has been communicating with the SMBus protocol, it will reset its slave interface and prepare to receive further communications.

4.2.6 SMBUS TIMEOUT

The CAP1126 includes an SMBus timeout feature. Following a 30ms period of inactivity on the SMBus where the SMCLK pin is held low, the device will timeout and reset the SMBus interface.

The timeout function defaults to disabled. It can be enabled by setting the TIMEOUT bit in the Configuration register (see [Section 6.6, "Configuration Registers"](#)).

4.2.7 SMBUS AND I²C COMPATIBILITY

The major differences between SMBus and I²C devices are highlighted here. For more information, refer to the SMBus 2.0 and I²C specifications. For information on using the CAP1126 in an I²C system, refer to AN 14.0 Dedicated Slave Devices in I²C Systems.

CAP1126

1. CAP1126 supports I²C fast mode at 400kHz. This covers the SMBus max time of 100kHz.
2. Minimum frequency for SMBus communications is 10kHz.
3. The SMBus slave protocol will reset if the clock is held at a logic '0' for longer than 30ms. This timeout functionality is disabled by default in the CAP1126 and can be enabled by writing to the TIMEOUT bit. I²C does not have a timeout.
4. The SMBus slave protocol will reset if both the clock and data lines are held at a logic '1' for longer than 200µs (idle condition). This function is disabled by default in the CAP1126 and can be enabled by writing to the TIMEOUT bit. I²C does not have an idle condition.
5. I²C devices do not support the Alert Response Address functionality (which is optional for SMBus).
6. I²C devices support block read and write differently. I²C protocol allows for unlimited number of bytes to be sent in either direction. The SMBus protocol requires that an additional data byte indicating number of bytes to read / write is transmitted. The CAP1126 supports I²C formatting only.

4.3 SMBus Protocols

The CAP1126 is SMBus 2.0 compatible and supports Write Byte, Read Byte, Send Byte, and Receive Byte as valid protocols as shown below.

All of the below protocols use the convention in [Table 4-2](#).

TABLE 4-2: PROTOCOL FORMAT

Data Sent to Device	Data Sent to the Host
Data sent	Data sent

4.3.1 SMBUS WRITE BYTE

The Write Byte is used to write one byte of data to a specific register as shown in [Table 4-3](#).

TABLE 4-3: WRITE BYTE PROTOCOL

Start	Slave Address	WR	ACK	Register Address	ACK	Register Data	ACK	Stop
1 -> 0	YYYY_YYY	0	0	XXh	0	XXh	0	0 -> 1

4.3.2 SMBUS READ BYTE

The Read Byte protocol is used to read one byte of data from the registers as shown in [Table 4-4](#).

TABLE 4-4: READ BYTE PROTOCOL

Start	Slave Address	WR	ACK	Register Address	ACK	Start	Slave Address	RD	ACK	Register Data	NACK	Stop
1->0	YYYY_YYY	0	0	XXh	0	1->0	YYYY_YYY	1	0	XXh	1	0->1

4.3.3 SMBUS SEND BYTE

The Send Byte protocol is used to set the internal address register pointer to the correct address location. No data is transferred during the Send Byte protocol as shown in [Table 4-5](#).

APPLICATION NOTE: The Send Byte protocol is not functional in Deep Sleep (i.e., DSLEEP bit is set).

TABLE 4-5: SEND BYTE PROTOCOL

Start	Slave Address	WR	ACK	Register Address	ACK	Stop
1 -> 0	YYYY_YYY	0	0	XXh	0	0 -> 1

CAP1126

4.3.4 SMBUS RECEIVE BYTE

The Receive Byte protocol is used to read data from a register when the internal register address pointer is known to be at the right location (e.g., set via Send Byte). This is used for consecutive reads of the same register as shown in [Table 4-6](#).

APPLICATION NOTE: The Receive Byte protocol is not functional in Deep Sleep (i.e., DSLEEP bit is set).

TABLE 4-6: RECEIVE BYTE PROTOCOL

Start	Slave Address	RD	ACK	Register Data	NACK	Stop
1 -> 0	YYYY_YYY	1	0	XXh	1	0 -> 1

4.4 I²C Protocols

The CAP1126 supports I²C Block Write and Block Read.

The protocols listed below use the convention in [Table 4-2](#).

4.4.1 BLOCK WRITE

The Block Write is used to write multiple data bytes to a group of contiguous registers as shown in [Table 4-7](#).

APPLICATION NOTE: When using the Block Write protocol, the internal address pointer will be automatically incremented after every data byte is received. It will wrap from FFh to 00h.

TABLE 4-7: BLOCK WRITE PROTOCOL

Start	Slave Address	WR	ACK	Register Address	ACK	Register Data	ACK
1 ->0	YYYY_YYY	0	0	XXh	0	XXh	0
Register Data	ACK	Register Data	ACK	...	Register Data	ACK	Stop
XXh	0	XXh	0	...	XXh	0	0 -> 1

4.4.2 BLOCK READ

The Block Read is used to read multiple data bytes from a group of contiguous registers as shown in [Table 4-8](#).

APPLICATION NOTE: When using the Block Read protocol, the internal address pointer will be automatically incremented after every data byte is received. It will wrap from FFh to 00h.

TABLE 4-8: BLOCK READ PROTOCOL

Start	Slave Address	WR	ACK	Register Address	ACK	Start	Slave Address	RD	ACK	Register Data
1->0	YYYY_YYY	0	0	XXh	0	1->0	YYYY_YYY	1	0	XXh
ACK	Register Data	ACK	Register Data	ACK	Register Data	ACK	...	Register Data	NACK	Stop
0	XXh	0	XXh	0	XXh	0	...	XXh	1	0 -> 1

4.5 SPI Interface

The SMBus has a predefined packet structure, the SPI does not. The SPI Bus can operate in two modes of operation, normal 4-wire mode and bi-directional 3-wire mode. All SPI commands consist of 8-bit packets sent to a specific slave device (identified by the CS pin).

The SPI bus will latch data on the rising edge of the clock and the clock and data both idle high.

All commands are supported via both operating modes. The supported commands are: Reset Serial interface, set address pointer, write command and read command. Note that all other codes received during the command phase are ignored and have no effect on the operation of the device.

FIGURE 4-2: SPI Timing

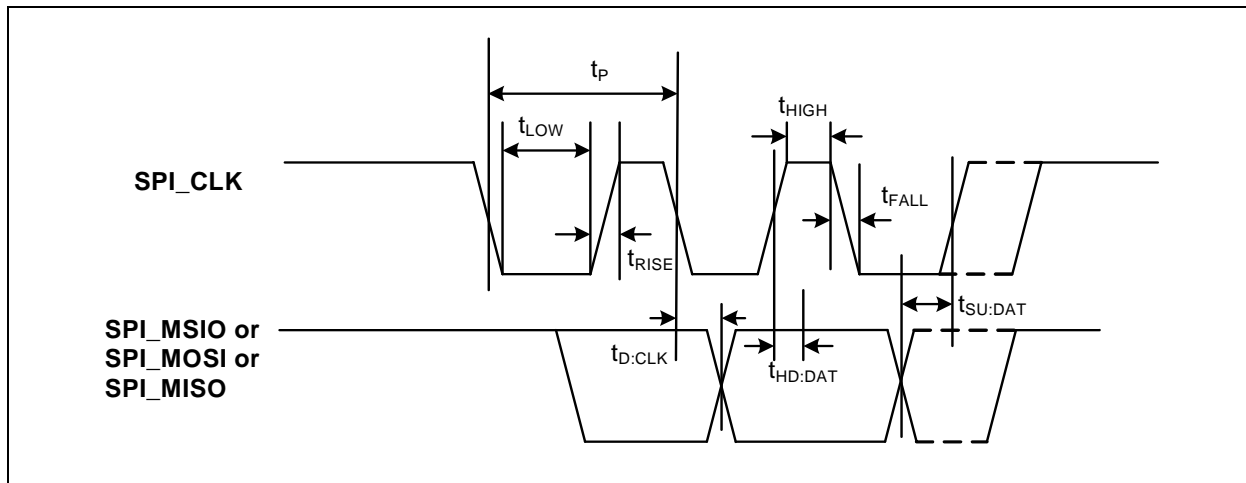

4.5.1 SPI NORMAL MODE

The SPI Bus can operate in two modes of operation, normal and bi-directional mode. In the normal mode of operation, there are dedicated input and output data lines. The host communicates by sending a command along the CAP1126 SPI_MOSI data line and reading data on the SPI_MISO data line. Both communications occur simultaneously which allows for larger throughput of data transactions.

All basic transfers consist of two 8 bit transactions from the Master device while the slave device is simultaneously sending data at the current address pointer value.

Data writes consist of two or more 8-bit transactions. The host sends a specific write command followed by the data to write the address pointer. Data reads consist of one or more 8-bit transactions. The host sends the specific read data command and continues clocking for as many data bytes as it wishes to receive.

4.5.2 SPI BI-DIRECTIONAL MODE

In the bi-directional mode of operation, the SPI data signals are combined into the SPI_MSIO line, which is shared for data received by the device and transmitted by the device. The protocol uses a simple handshake and turn around sequence for data communications based on the number of clocks transmitted during each phase.

All basic transfers consist of two 8 bit transactions. The first is an 8 bit command phase driven by the Master device. The second is by an 8 bit data phase driven by the Master for writes, and by the CAP1126 for read operations.

The auto increment feature of the address pointer allows for successive reads or writes. The address pointer will return to 00h after reaching FFh.

4.5.3 SPI_CS# PIN

The SPI Bus is a single master, multiple slave serial bus. Each slave has a dedicated CS pin (chip select) that the master asserts low to identify that the slave is being addressed. There are no formal addressing options.

4.5.4 ADDRESS POINTER

All data writes and reads are accessed from the current address pointer. In both Bi-directional mode and Full Duplex mode, the Address pointer is automatically incremented following every read command or every write command.

The address pointer will return to 00h after reaching FFh.

4.5.5 SPI TIMEOUT

The CAP1126 does not detect any timeout conditions on the SPI bus.

CAP1126

FIGURE 4-4: SPI Reset Interface Command - Normal Mode

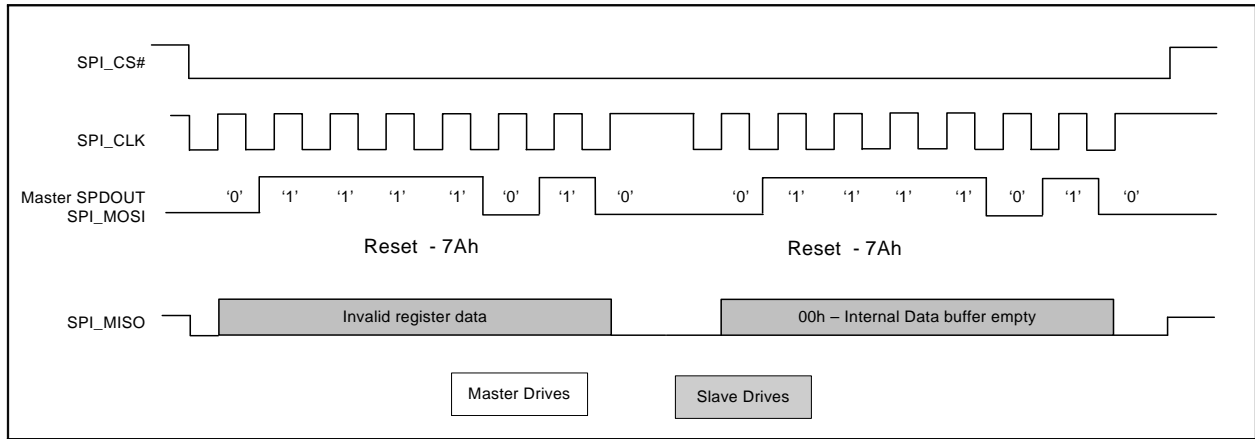

4.6.2 SET ADDRESS POINTER

The Set Address Pointer command sets the Address pointer for subsequent reads and writes of data. The pointer is set on the rising edge of the final data bit. At the same time, the data that is to be read is fetched and loaded into the internal output buffer but is not transmitted.

FIGURE 4-5: SPI Set Address Pointer Command - Normal Mode

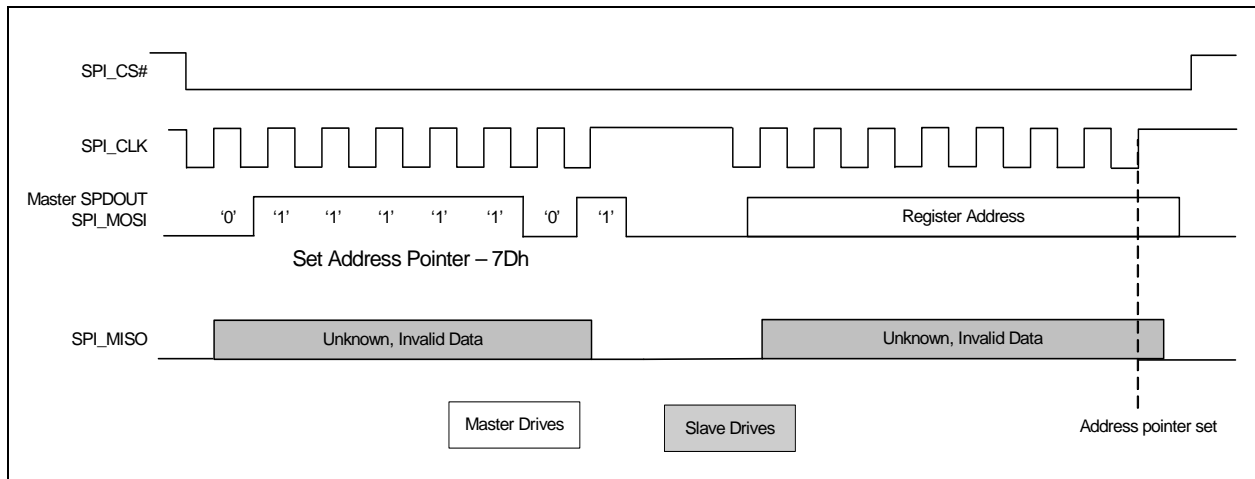

4.6.3 WRITE DATA

The Write Data protocol updates the contents of the register referenced by the address pointer. As the command is processed, the data to be read is fetched and loaded into the internal output buffer but not transmitted. Then, the register is updated with the data to be written. Finally, the address pointer is incremented.

CAP1126

FIGURE 4-6: SPI Write Command - Normal Mode

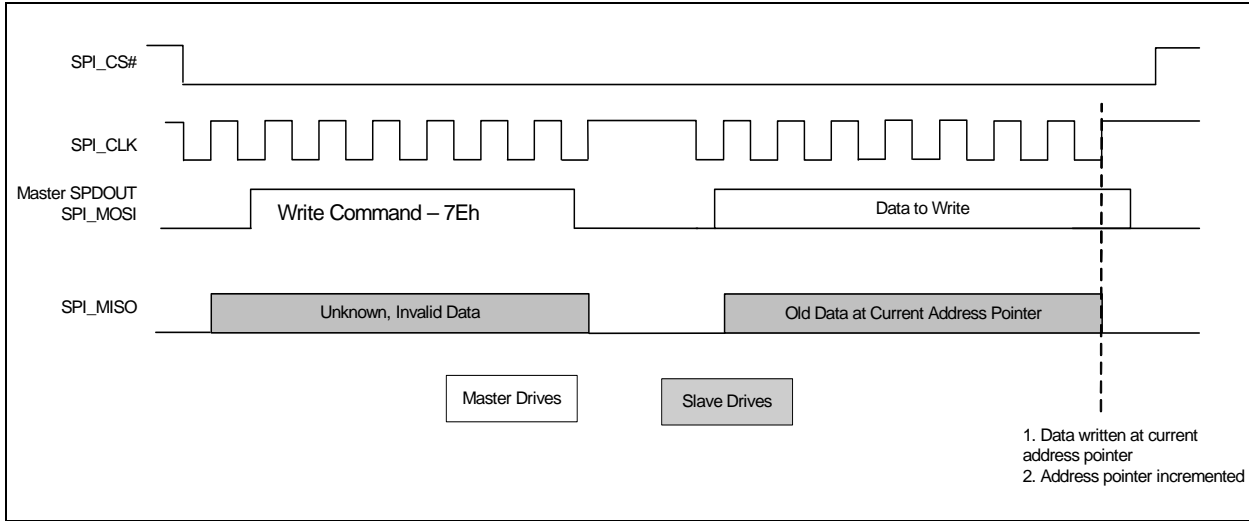

4.6.4 READ DATA

The Read Data protocol is used to read data from the device. During the normal mode of operation, while the device is receiving data, the CAP1126 is simultaneously transmitting data to the host. For the Set Address commands and the Write Data commands, this data may be invalid and it is recommended that the Read Data command is used.

FIGURE 4-7: SPI Read Command - Normal Mode

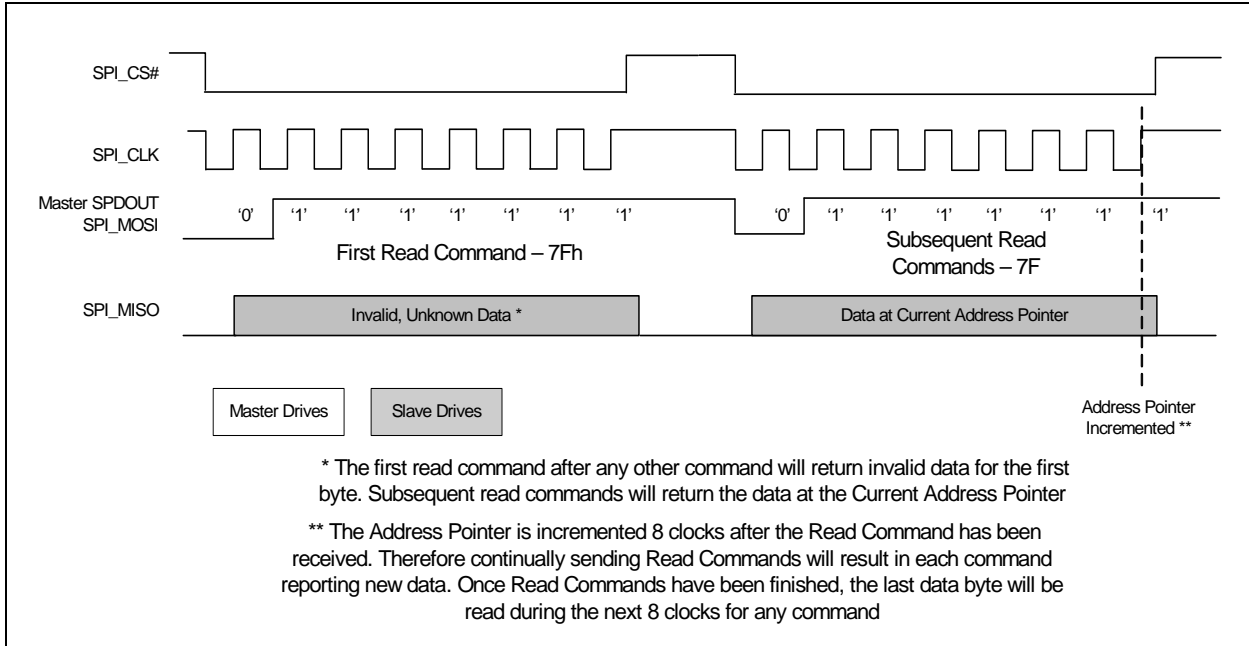
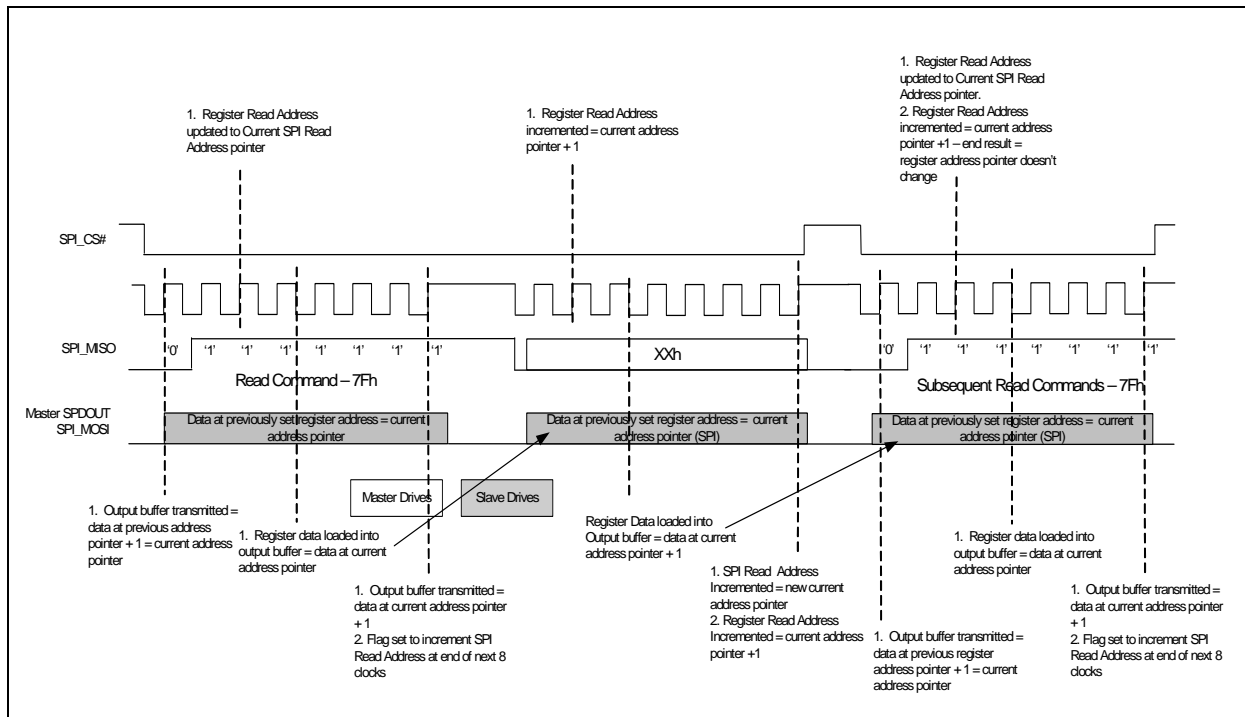

FIGURE 4-8: SPI Read Command - Normal Mode - Full



4.7 Bi-Directional SPI Protocols

4.7.1 RESET INTERFACE

Resets the Serial interface whenever two successive 7Ah codes are received. Regardless of the current phase of the transaction - command or data, the receipt of the successive reset commands resets the Serial communication interface only. All other functions are not affected by the reset operation.

FIGURE 4-9: SPI Reset Interface Command - Bi-directional Mode

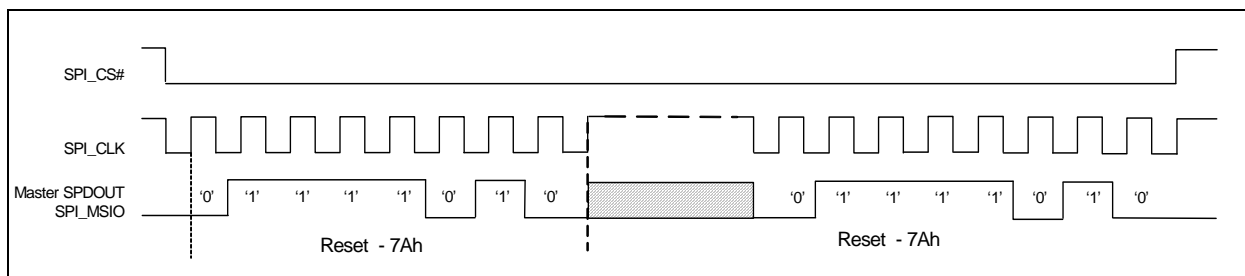

4.7.2 SET ADDRESS POINTER

Sets the address pointer to the register to be accessed by a read or write command. This command overrides the auto-incrementing of the address pointer.

CAP1126

FIGURE 4-10: SPI Set Address Pointer Command - Bi-directional Mode

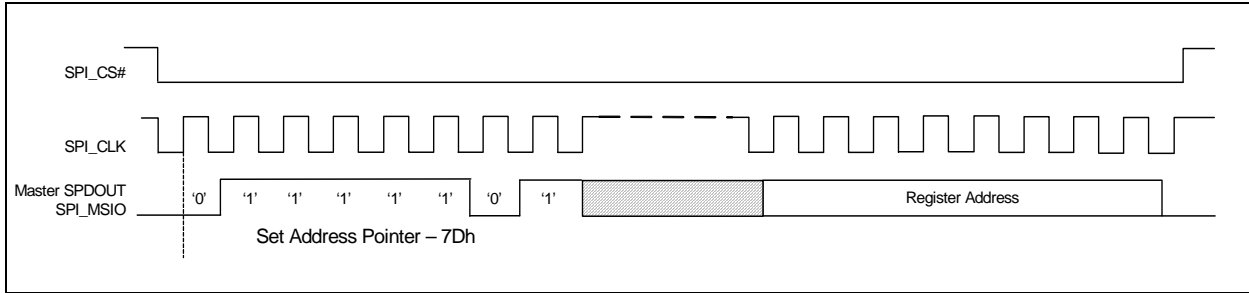

4.7.3 WRITE DATA

Writes data value to the register address stored in the address pointer. Performs auto increment of address pointer after the data is loaded into the register.

FIGURE 4-11: SPI Write Data Command - Bi-directional Mode

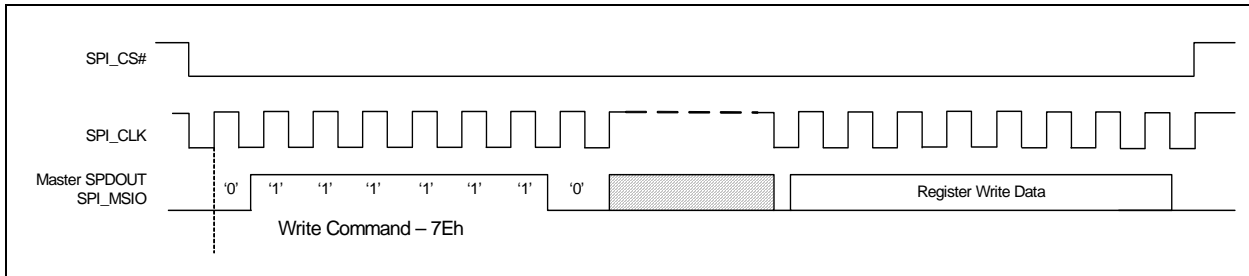

4.7.4 READ DATA

Reads data referenced by the address pointer. Performs auto increment of address pointer after the data is transferred to the Master.

FIGURE 4-12: SPI Read Data Command - Bi-directional Mode

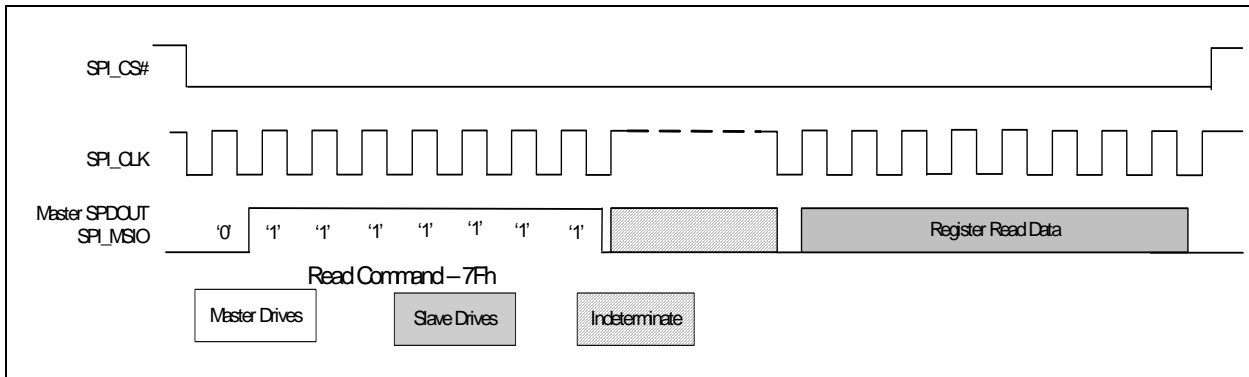

4.8 BC-Link Interface

The BC-Link is a proprietary bus developed to allow communication between a host controller device to a companion device. This device uses this serial bus to read and write registers and for interrupt processing. The interface uses a data port concept, where the base interface has an address register, data register and a control register, defined in the 8051's SFR space.

Refer to documentation for the BC-Link compatible host controller for details on how to access the CAP1126 via the BC-Link Interface.

CAP1126

5.0 GENERAL DESCRIPTION

The CAP1126 is a multiple channel Capacitive Touch sensor with multiple power LED drivers. It contains six (6) individual capacitive touch sensor inputs with programmable sensitivity for use in touch sensor applications. Each sensor input automatically recalibrates to compensate for gradual environmental changes.

The CAP1126 also contains two (2) low side (or push-pull) LED drivers that offer full-on / off, variable rate blinking, dimness controls, and breathing. Each of the LED drivers may be linked to one of the sensor inputs to be actuated when a touch is detected. As well, each LED driver may be individually controlled via a host controller.

Finally, the device contains a dedicated RESET pin to act as a soft reset by the system.

The CAP1126 offers multiple power states. It operates at the lowest quiescent current during its Deep Sleep state. In the low power Standby state, it can monitor one or more channels and respond to communications normally. The device contains a wake pin (WAKE/SPI_MOSI) output to wake the system when a touch is detected in Standby and to wake the device from Deep Sleep.

The device communicates with a host controller using the SPI bus, or via SMBus / I²C. The host controller may poll the device for updated information at any time or it may configure the device to flag an interrupt whenever a touch is detected on any sensor pad.

A typical system diagram is shown in [Figure 5-1](#).

CAP1126

FIGURE 5-1: System Diagram for CAP1126

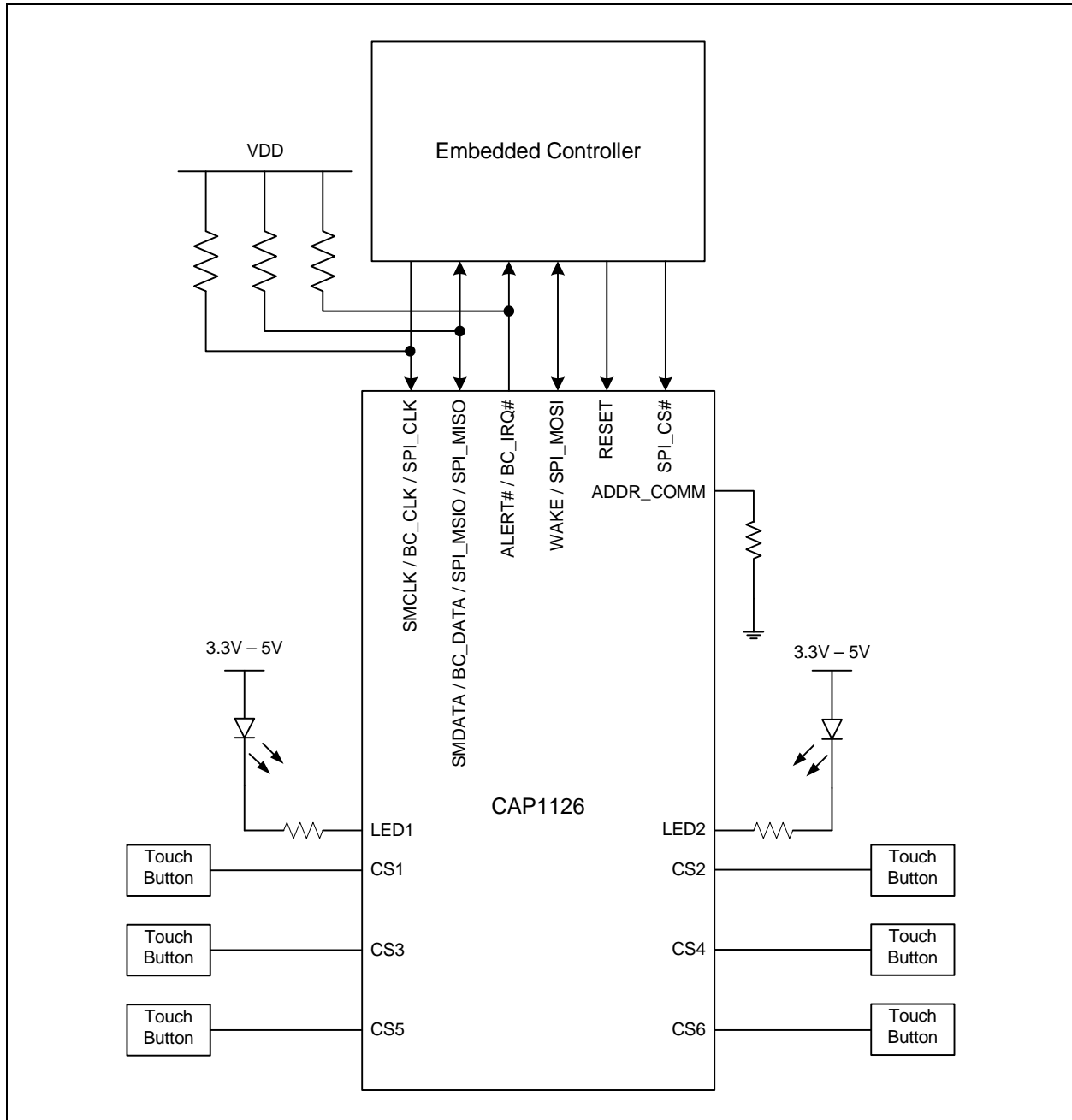

5.1 Power States

The CAP1126 has three operating states depending on the status of the STBY and DSLEEP bits. When the device transitions between power states, previously detected touches (for inactive channels) are cleared and the status bits reset.

1. Fully Active - The device is fully active. It is monitoring all active capacitive sensor inputs and driving all LED channels as defined.
2. Standby - The device is in a lower power state. It will measure a programmable number of channels using the Standby Configuration controls (see [Section 6.20](#) through [Section 6.22](#)). Interrupts will still be generated based on the active channels. The device will still respond to communications normally and can be returned to the Fully Active state of operation by clearing the STBY bit.

3. Deep Sleep - The device is in its lowest power state. It is not monitoring any capacitive sensor inputs and not driving any LEDs. All LEDs will be driven to their programmed non-actuated state and no PWM operations will be done. While in Deep Sleep, the device can be awakened by SMBus or SPI communications targeting the device. This will not cause the DSLEEP to be cleared so the device will return to Deep Sleep once all communications have stopped.

If the device is not communicating via the 4-wire SPI bus, then during this state of operation, if the WAKE/SPI_MOSI pin is driven high by an external source, the device will clear the DSLEEP bit and return to Fully Active.

APPLICATION NOTE: In the Deep Sleep state, the LED output will be either high or low and will not be PWM'd at the min or max duty cycle.

5.2 RESET Pin

The RESET pin is an active high reset that is driven from an external source. While it is asserted high, all the internal blocks will be held in reset including the communications protocol used. No capacitive touch sensor inputs will be sampled and the LEDs will not be driven. All configuration settings will be reset to default states and all readings will be cleared.

The device will be held in Deep Sleep that can only be removed by driving the RESET pin low. This will cause the RESET status bit to be set to a logic '1' and generate an interrupt.

5.3 WAKE/SPI_MOSI Pin Operation

The WAKE / SPI_MOSI pin is a multi-function pin depending on device operation. When the device is configured to communicate using the 4-wire SPI bus, this pin is an input.

However, when the CAP1126 is placed in Standby and is not communicating using the 4-wire SPI protocol, the WAKE pin is an active high output. In this condition, the device will assert the WAKE/SPI_MOSI pin when a touch is detected on one of its sampled sensor inputs. The pin will remain asserted until the INT bit has been cleared and then it will be de-asserted.

When the CAP1126 is placed in Deep Sleep and it is not communicating using the 4-wire SPI protocol, the WAKE/SPI_MOSI pin is monitored by the device as an input. If the WAKE/SPI_MOSI pin is driven high by an external source, the CAP1126 will clear the DSLEEP bit causing the device to return to Fully Active.

When the device is placed in Deep Sleep, this pin is a High-Z input and must have a pull-down resistor to GND for proper operation.

5.4 LED Drivers

The CAP1126 contains two (2) LED drivers. Each LED driver can be linked to its respective capacitive touch sensor input or it can be controlled by the host. Each LED driver can be configured to operate in one of the following modes with either push-pull or open drain drive.

1. Direct - The LED is configured to be on or off when the corresponding input stimulus is on or off (or inverted). The brightness of the LED can be programmed from full off to full on (default). Additionally, the LED contains controls to individually configure ramping on, off, and turn-off delay.
2. Pulse 1 - The LED is configured to "Pulse" (transition ON-OFF-ON) a programmable number of times with programmable rate and min / max brightness. This behavior may be actuated when a press is detected or when a release is detected.
3. Pulse 2 - The LED is configured to "Pulse" while actuated and then "Pulse" a programmable number of times with programmable rate and min / max brightness when the sensor pad is released.
4. Breathe - The LED is configured to transition continuously ON-OFF-ON (i.e. to "Breathe") with a programmable rate and min / max brightness.

When an LED is not linked to a sensor and is actuated by the host, there's an option to assert the ALERT# pin when the initiated LED behavior has completed.

5.4.1 LINKING LEDS TO CAPACITIVE TOUCH SENSOR INPUTS

All LEDs can be linked to the corresponding capacitive touch sensor input so that when the sensor input detects a touch, the corresponding LED will be actuated at one of the programmed responses.

CAP1126

5.5 Capacitive Touch Sensing

The CAP1126 contains six (6) independent capacitive touch sensor inputs. Each sensor input has dynamic range to detect a change of capacitance due to a touch. Additionally, each sensor input can be configured to be automatically and routinely re-calibrated.

5.5.1 SENSING CYCLE

Each capacitive touch sensor input has controls to be activated and included in the sensing cycle. When the device is active, it automatically initiates a sensing cycle and repeats the cycle every time it finishes. The cycle polls through each active sensor input starting with CS1 and extending through CS6. As each capacitive touch sensor input is polled, its measurement is compared against a baseline “Not Touched” measurement. If the delta measurement is large enough, a touch is detected and an interrupt is generated.

The sensing cycle time is programmable (see [Section 6.10, "Averaging and Sampling Configuration Register"](#)).

5.5.2 RECALIBRATING SENSOR INPUTS

There are various options for recalibrating the capacitive touch sensor inputs. Recalibration re-sets the Base Count Registers ([Section 6.24, "Sensor Input Base Count Registers"](#)) which contain the “not touched” values used for touch detection comparisons.

APPLICATION NOTE: The device will recalibrate all sensor inputs that were disabled when it transitions from Standby. Likewise, the device will recalibrate all sensor inputs when waking out of Deep Sleep.

5.5.2.1 Manual Recalibration

The Calibration Activate Registers ([Section 6.11, "Calibration Activate Register"](#)) force recalibration of selected sensor inputs. When a bit is set, the corresponding capacitive touch sensor input will be recalibrated (both analog and digital). The bit is automatically cleared once the recalibration routine has finished.

Note: During this recalibration routine, the sensor inputs will not detect a press for up to 200ms and the Sensor Base Count Register values will be invalid. In addition, any press on the corresponding sensor pads will invalidate the recalibration.

5.5.2.2 Automatic Recalibration

Each sensor input is regularly recalibrated at a programmable rate (see [Section 6.17, "Recalibration Configuration Register"](#)). By default, the recalibration routine stores the average 64 previous measurements and periodically updates the base “not touched” setting for the capacitive touch sensor input.

Note: Automatic recalibration only works when the delta count is below the active sensor input threshold. It is disabled when a touch is detected.

5.5.2.3 Negative Delta Count Recalibration

It is possible that the device loses sensitivity to a touch. This may happen as a result of a noisy environment, an accidental recalibration during a touch, or other environmental changes. When this occurs, the base untouched sensor input may generate negative delta count values. The NEG_DELTA_CNT bits (see [Section 6.17, "Recalibration Configuration Register"](#)) can be set to force a recalibration after a specified number of consecutive negative delta readings.

Note: During this recalibration, the device will not respond to touches.

5.5.2.4 Delayed Recalibration

It is possible that a “stuck button” occurs when something is placed on a button which causes a touch to be detected for a long period. By setting the MAX_DUR_EN bit (see [Section 6.6, "Configuration Registers"](#)), a recalibration can be forced when a touch is held on a button for longer than the duration specified in the MAX_DUR bits (see [Section 6.8, "Sensor Input Configuration Register"](#)).

Note: Delayed recalibration only works when the delta count is above the active sensor input threshold. If enabled, it is invoked when a sensor pad touch is held longer than the MAX_DUR bit setting.

5.5.3 PROXIMITY DETECTION

Each sensor input can be configured to detect changes in capacitance due to proximity of a touch. This circuitry detects the change of capacitance that is generated as an object approaches, but does not physically touch, the enabled sensor pad(s). When a sensor input is selected to perform proximity detection, it will be sampled from 1x to 128x per sampling cycle. The larger the number of samples that are taken, the greater the range of proximity detection is available at the cost of an increased overall sampling time.

5.5.4 MULTIPLE TOUCH PATTERN DETECTION

The multiple touch pattern (MTP) detection circuitry can be used to detect lid closure or other similar events. An event can be flagged based on either a minimum number of sensor inputs or on specific sensor inputs simultaneously exceeding an MTP threshold or having their Noise Flag Status Register bits set. An interrupt can also be generated. During an MTP event, all touches are blocked (see [Section 6.15, "Multiple Touch Pattern Configuration Register"](#)).

5.5.5 LOW FREQUENCY NOISE DETECTION

Each sensor input has an EMI noise detector that will sense if low frequency noise is injected onto the input with sufficient power to corrupt the readings. If this occurs, the device will reject the corrupted sample and set the corresponding bit in the Noise Status register to a logic '1'.

5.5.6 RF NOISE DETECTION

Each sensor input contains an integrated RF noise detector. This block will detect injected RF noise on the CS pin. The detector threshold is dependent upon the noise frequency. If RF noise is detected on a CS line, that sample is removed and not compared against the threshold.

5.6 ALERT# Pin

The ALERT# pin is an active low (or active high when configured) output that is driven when an interrupt event is detected.

Whenever an interrupt is generated, the INT bit (see [Section 6.1, "Main Control Register"](#)) is set. The ALERT# pin is cleared when the INT bit is cleared by the user. Additionally, when the INT bit is cleared by the user, status bits are only cleared if no touch is detected.

5.6.1 SENSOR INTERRUPT BEHAVIOR

The sensor interrupts are generated in one of two ways:

1. An interrupt is generated when a touch is detected and, as a user selectable option, when a release is detected (by default - see [Section 6.6](#)). See [Figure 5-3](#).
2. If the repeat rate is enabled then, so long as the touch is held, another interrupt will be generated based on the programmed repeat rate (see [Figure 5-2](#)).

When the repeat rate is enabled, the device uses an additional control called MPRESS that determines whether a touch is flagged as a simple "touch" or a "press and hold". The MPRESS[3:0] bits set a minimum press timer. When the button is touched, the timer begins. If the sensor pad is released before the minimum press timer expires, it is flagged as a touch and an interrupt is generated upon release. If the sensor input detects a touch for longer than this timer value, it is flagged as a "press and hold" event. So long as the touch is held, interrupts will be generated at the programmed repeat rate and upon release (if enabled).

APPLICATION NOTE: [Figure 5-2](#) and [Figure 5-3](#) show default operation which is to generate an interrupt upon sensor pad release and an active-low ALERT# pin.

APPLICATION NOTE: The host may need to poll the device twice to determine that a release has been detected.

FIGURE 5-2: Sensor Interrupt Behavior - Repeat Rate Enabled

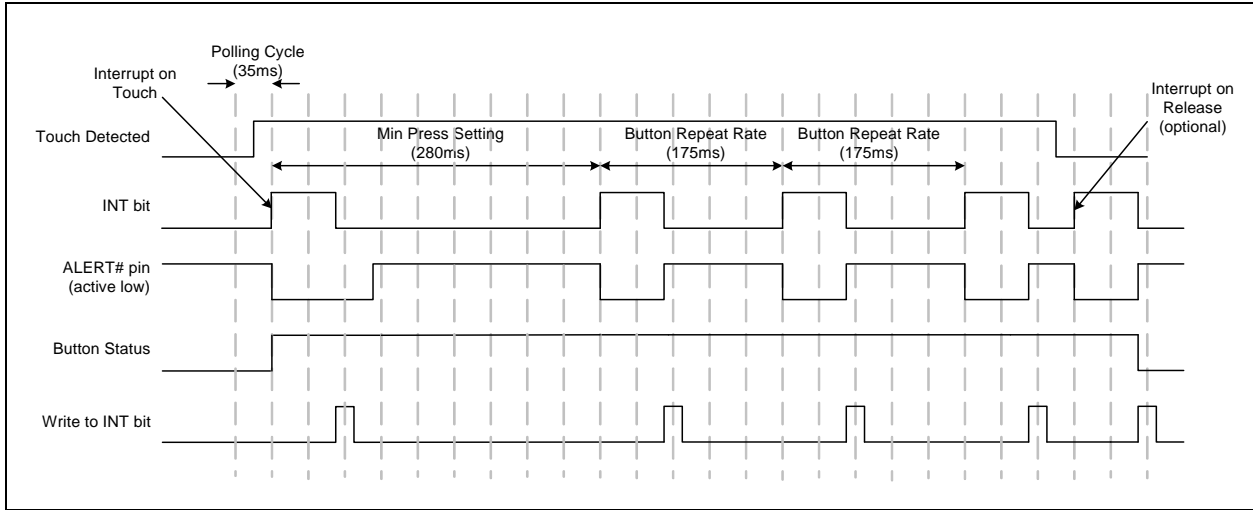
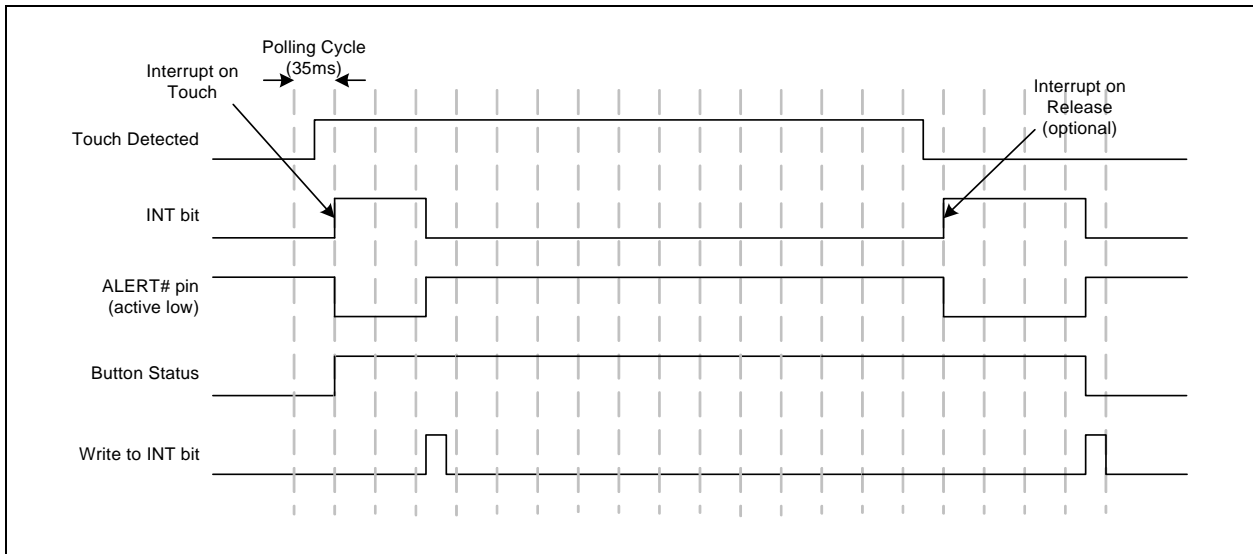

FIGURE 5-3: Sensor Interrupt Behavior - No Repeat Rate Enabled



CAP1126

6.0 REGISTER DESCRIPTION

The registers shown in [Table 6-1](#) are accessible through the communications protocol. An entry of '-' indicates that the bit is not used and will always read '0'.

TABLE 6-1: REGISTER SET IN HEXADECIMAL ORDER

Register Address	R/W	Register Name	Function	Default Value	Page
00h	R/W	Main Control	Controls general power states and power dissipation	00h	Page 31
02h	R	General Status	Stores general status bits	00h	Page 32
03h	R	Sensor Input Status	Returns the state of the sampled capacitive touch sensor inputs	00h	Page 32
04h	R	LED Status	Stores status bits for LEDs	00h	Page 32
0Ah	R	Noise Flag Status	Stores the noise flags for sensor inputs	00h	Page 33
10h	R	Sensor Input 1 Delta Count	Stores the delta count for CS1	00h	Page 33
11h	R	Sensor Input 2 Delta Count	Stores the delta count for CS2	00h	Page 33
12h	R	Sensor Input 3 Delta Count	Stores the delta count for CS3	00h	Page 33
13h	R	Sensor Input 4 Delta Count	Stores the delta count for CS4	00h	Page 33
14h	R	Sensor Input 5 Delta Count	Stores the delta count for CS5	00h	Page 33
15h	R	Sensor Input 6 Delta Count	Stores the delta count for CS6	00h	Page 33
1Fh	R/W	Sensitivity Control	Controls the sensitivity of the threshold and delta counts and data scaling of the base counts	2Fh	Page 33
20h	R/W	Configuration	Controls general functionality	20h	Page 35
21h	R/W	Sensor Input Enable	Controls whether the capacitive touch sensor inputs are sampled	3Fh	Page 36
22h	R/W	Sensor Input Configuration	Controls max duration and auto-repeat delay for sensor inputs operating in the full power state	A4h	Page 36
23h	R/W	Sensor Input Configuration 2	Controls the MPRESS controls for all sensor inputs	07h	Page 38
24h	R/W	Averaging and Sampling Config	Controls averaging and sampling window	39h	Page 38
26h	R/W	Calibration Activate	Forces re-calibration for capacitive touch sensor inputs	00h	Page 39
27h	R/W	Interrupt Enable	Enables Interrupts associated with capacitive touch sensor inputs	3Fh	Page 40
28h	R/W	Repeat Rate Enable	Enables repeat rate for all sensor inputs	3Fh	Page 40
2Ah	R/W	Multiple Touch Configuration	Determines the number of simultaneous touches to flag a multiple touch condition	80h	Page 41
2Bh	R/W	Multiple Touch Pattern Configuration	Determines the multiple touch pattern (MTP) configuration	00h	Page 41

CAP1126

TABLE 6-1: REGISTER SET IN HEXADECIMAL ORDER (CONTINUED)

Register Address	R/W	Register Name	Function	Default Value	Page
2Dh	R/W	Multiple Touch Pattern	Determines the pattern or number of sensor inputs used by the MTP circuitry	3Fh	Page 42
2Fh	R/W	Recalibration Configuration	Determines re-calibration timing and sampling window	8Ah	Page 43
30h	R/W	Sensor Input 1 Threshold	Stores the delta count threshold to determine a touch for Capacitive Touch Sensor Input 1	40h	Page 44
31h	R/W	Sensor Input 2 Threshold	Stores the delta count threshold to determine a touch for Capacitive Touch Sensor Input 2	40h	Page 44
32h	R/W	Sensor Input 3 Threshold	Stores the delta count threshold to determine a touch for Capacitive Touch Sensor Input 3	40h	Page 44
33h	R/W	Sensor Input 4 Threshold	Stores the delta count threshold to determine a touch for Capacitive Touch Sensor Input 4	40h	Page 44
34h	R/W	Sensor Input 5 Threshold	Stores the delta count threshold to determine a touch for Capacitive Touch Sensor Input 5	40h	Page 44
35h	R/W	Sensor Input 6 Threshold	Stores the delta count threshold to determine a touch for Capacitive Touch Sensor Input 6	40h	Page 44
38h	R/W	Sensor Input Noise Threshold	Stores controls for selecting the noise threshold for all sensor inputs	01h	Page 44
Standby Configuration Registers					
40h	R/W	Standby Channel	Controls which sensor inputs are enabled while in standby	00h	Page 45
41h	R/W	Standby Configuration	Controls averaging and cycle time while in standby	39h	Page 45
42h	R/W	Standby Sensitivity	Controls sensitivity settings used while in standby	02h	Page 47
43h	R/W	Standby Threshold	Stores the touch detection threshold for active sensor inputs in standby	40h	Page 47
44h	R/W	Configuration 2	Stores additional configuration controls for the device	40h	Page 35
Base Count Registers					
50h	R	Sensor Input 1 Base Count	Stores the reference count value for sensor input 1	C8h	Page 47
51h	R	Sensor Input 2 Base Count	Stores the reference count value for sensor input 2	C8h	Page 47
52h	R	Sensor Input 3 Base Count	Stores the reference count value for sensor input 3	C8h	Page 47
53h	R	Sensor Input 4 Base Count	Stores the reference count value for sensor input 4	C8h	Page 47
54h	R	Sensor Input 5 Base Count	Stores the reference count value for sensor input 5	C8h	Page 47
55h	R	Sensor Input 6 Base Count	Stores the reference count value for sensor input 6	C8h	Page 47

CAP1126

TABLE 6-1: REGISTER SET IN HEXADECIMAL ORDER (CONTINUED)

Register Address	R/W	Register Name	Function	Default Value	Page
LED Controls					
71h	R/W	LED Output Type	Controls the output type for the LED outputs	00h	Page 48
72h	R/W	Sensor Input LED Linking	Controls linking of sensor inputs to LED channels	00h	Page 48
73h	R/W	LED Polarity	Controls the output polarity of LEDs	00h	Page 49
74h	R/W	LED Output Control	Controls the output state of the LEDs	00h	Page 50
77h	R/W	Linked LED Transition Control	Controls the transition when LEDs are linked to CS channels	00h	Page 51
79h	R/W	LED Mirror Control	Controls the mirroring of duty cycles for the LEDs	00h	Page 51
81h	R/W	LED Behavior 1	Controls the behavior and response of LEDs 1 - 2	00h	Page 51
84h	R/W	LED Pulse 1 Period	Controls the period of each breathe during a pulse	20h	Page 53
85h	R/W	LED Pulse 2 Period	Controls the period of the breathing during breathe and pulse operation	14h	Page 55
86h	R/W	LED Breathe Period	Controls the period of an LED breathe operation	5Dh	Page 56
88h	R/W	LED Config	Controls LED configuration	04h	Page 56
90h	R/W	LED Pulse 1 Duty Cycle	Determines the min and max duty cycle for the pulse operation	F0h	Page 57
91h	R/W	LED Pulse 2 Duty Cycle	Determines the min and max duty cycle for breathe and pulse operation	F0h	Page 57
92h	R/W	LED Breathe Duty Cycle	Determines the min and max duty cycle for the breathe operation	F0h	Page 57
93h	R/W	LED Direct Duty Cycle	Determines the min and max duty cycle for Direct mode LED operation	F0h	Page 57
94h	R/W	LED Direct Ramp Rates	Determines the rising and falling edge ramp rates of the LEDs	00h	Page 58
95h	R/W	LED Off Delay	Determines the off delay for all LED behaviors	00h	Page 58
B1h	R	Sensor Input 1 Calibration	Stores the upper 8-bit calibration value for sensor input 1	00h	Page 61
B2h	R	Sensor Input 2 Calibration	Stores the upper 8-bit calibration value for sensor input 2	00h	Page 61
B3h	R	Sensor Input 3 Calibration	Stores the upper 8-bit calibration value for sensor input 3	00h	Page 61
B4h	R	Sensor Input 4 Calibration	Stores the upper 8-bit calibration value for sensor input 4	00h	Page 61
B5h	R	Sensor Input 5 Calibration	Stores the upper 8-bit calibration value for sensor input 5	00h	Page 61
B6h	R	Sensor Input 6 Calibration	Stores the upper 8-bit calibration value for sensor input 6	00h	Page 61
B9h	R	Sensor Input Calibration LSB 1	Stores the 2 LSBs of the calibration value for sensor inputs 1 - 4	00h	Page 61
BAh	R	Sensor Input Calibration LSB 2	Stores the 2 LSBs of the calibration value for sensor inputs 5 - 6	00h	Page 61

CAP1126

TABLE 6-1: REGISTER SET IN HEXADECIMAL ORDER (CONTINUED)

Register Address	R/W	Register Name	Function	Default Value	Page
FDh	R	Product ID	Stores a fixed value that identifies each product	53h	Page 62
FEh	R	Manufacturer ID	Stores a fixed value that identifies Microchip	5Dh	Page 62
FFh	R	Revision	Stores a fixed value that represents the revision number	83h	Page 62

During Power-On-Reset (POR), the default values are stored in the registers. A POR is initiated when power is first applied to the part and the voltage on the VDD supply surpasses the POR level as specified in the electrical characteristics. Any reads to undefined registers will return 00h. Writes to undefined registers will not have an effect.

When a bit is “set”, this means that the user writes a logic ‘1’ to it. When a bit is “cleared”, this means that the user writes a logic ‘0’ to it.

6.1 Main Control Register

TABLE 6-2: MAIN CONTROL REGISTER

ADDR	R/W	Register	B7	B6	B5	B4	B3	B2	B1	B0	Default
00h	R/W	Main Control	GAIN[1:0]		STBY	DSLEEP	-	-	-	INT	00h

The Main Control register controls the primary power state of the device.

Bits 7 - 6 - GAIN[1:0] - Controls the gain used by the capacitive touch sensing circuitry. As the gain is increased, the effective sensitivity is likewise increased as a smaller delta capacitance is required to generate the same delta count values. The sensitivity settings may need to be adjusted along with the gain settings such that data overflow does not occur.

APPLICATION NOTE: The gain settings apply to both Standby and Active states.

TABLE 6-3: GAIN BIT DECODE

GAIN[1:0]		Capacitive Touch Sensor Gain
1	0	
0	0	1
0	1	2
1	0	4
1	1	8

Bit 5 - STBY - Enables Standby.

- ‘0’ (default) - Sensor input scanning is active and LEDs are functional.
- ‘1’ - Capacitive touch sensor input scanning is limited to the sensor inputs set in the Standby Channel register (see [Section 6.20](#)). The status registers will not be cleared until read. LEDs that are linked to capacitive touch sensor inputs will remain linked and active. Sensor inputs that are no longer sampled will flag a release and then remain in a non-touched state. LEDs that are manually controlled will be unaffected.
- Bit 4 - DSLEEP - Enables Deep Sleep by deactivating all functions. This bit will be cleared when the WAKE pin is driven high. ‘0’ (default) - Sensor input scanning is active and LEDs are functional.
- ‘1’ - All sensor input scanning is disabled. All LEDs are driven to their programmed non-actuated state and no PWM operations will be done. The status registers are automatically cleared and the INT bit is cleared.

Bit 0 - INT - Indicates that there is an interrupt. When this bit is set, it asserts the ALERT# pin. If a channel detects a touch and its associated interrupt enable bit is not set to a logic ‘1’, no action is taken.

CAP1126

This bit is cleared by writing a logic '0' to it. When this bit is cleared, the ALERT# pin will be deasserted and all status registers will be cleared if the condition has been removed. If the WAKE/SPI_MOSI pin is asserted as a result of a touch detected while in Standby, it will likewise be deasserted when this bit is cleared.

Note that the WAKE / SPI_MOSI pin is not driven when communicating via the 4-wire SPI protocol.

- '0' - No interrupt pending.
- '1' - A touch has been detected on one or more channels and the interrupt has been asserted.

6.2 Status Registers

TABLE 6-4: STATUS REGISTERS

ADDR	R/W	Register	B7	B6	B5	B4	B3	B2	B1	B0	Default
02h	R	General Status	-	-	-	LED	RESET	MULT	MTP	TOUCH	00h
03h	R	Sensor Input Status	-	-	CS6	CS5	CS4	CS3	CS2	CS1	00h
04h	R	LED Status	-	-	-	-	-	-	LED2_DN	LED1_DN	00h

All status bits are cleared when the device enters the Deep Sleep (DSLEEP = '1' - see [Section 6.1](#)).

6.2.1 GENERAL STATUS - 02H

Bit 4 - LED - Indicates that one or more LEDs have finished their programmed activity. This bit is set if any bit in the LED Status register is set.

Bit 3 - RESET - Indicates that the device has come out of reset. This bit is set when the device exits a POR state or when the RESET pin has been deasserted and qualified via the RESET pin filter (see [Section 5.2](#)). This bit will cause the INT bit to be set and is cleared when the INT bit is cleared.

Bit 2 - MULT - Indicates that the device is blocking detected touches due to the Multiple Touch detection circuitry (see [Section 6.14](#)). This bit will not cause the INT bit to be set and hence will not cause an interrupt.

Bit 1 - MTP - Indicates that the device has detected a number of sensor inputs that exceed the MTP threshold either via the pattern recognition or via the number of sensor inputs (see [Section 6.15](#)). This bit will cause the INT bit to be set if the MTP_ALERT bit is also set. This bit will not be cleared until the condition that caused it to be set has been removed.

Bit 0 - TOUCH - Indicates that a touch was detected. This bit is set if any bit in the Sensor Input Status register is set.

6.2.2 SENSOR INPUT STATUS - 03H

The Sensor Input Status Register stores status bits that indicate a touch has been detected. A value of '0' in any bit indicates that no touch has been detected. A value of '1' in any bit indicates that a touch has been detected.

All bits are cleared when the INT bit is cleared and if a touch on the respective capacitive touch sensor input is no longer present. If a touch is still detected, the bits will not be cleared (but this will not cause the interrupt to be asserted - see [Section 6.6](#)).

Bit 5 - CS6 - Indicates that a touch was detected on Sensor Input 6.

Bit 4 - CS5 - Indicates that a touch was detected on Sensor Input 5.

Bit 3 - CS4 - Indicates that a touch was detected on Sensor Input 4.

Bit 2 - CS3 - Indicates that a touch was detected on Sensor Input 3.

Bit 1 - CS2 - Indicates that a touch was detected on Sensor Input 2. This sensor input can be linked to LED2.

Bit 0 - CS1 - Indicates that a touch was detected on Sensor Input 1. This sensor input can be linked to LED1.

6.2.3 LED STATUS - 04H

The LED Status Registers indicate when an LED has completed its configured behavior (see [Section 6.31, "LED Behavior Register"](#)) after being actuated by the host (see [Section 6.28, "LED Output Control Register"](#)). These bits are ignored when the LED is linked to a capacitive sensor input. All LED Status bits are cleared when the INT bit is cleared.

Bit 1 - LED2_DN - Indicates that LED2 has finished its behavior after being actuated by the host.

Bit 0 - LED1_DN - Indicates that LED1 has finished its behavior after being actuated by the host.

CAP1126

6.3 Noise Flag Status Registers

TABLE 6-5: NOISE FLAG STATUS REGISTERS

ADDR	R/W	Register	B7	B6	B5	B4	B3	B2	B1	B0	Default
0Ah	R	Noise Flag Status	-	-	CS6_ NOISE	CS5_ NOISE	CS4_ NOISE	CS3_ NOISE	CS2_ NOISE	CS1_ NOISE	00h

The Noise Flag Status registers store status bits that are generated from the analog block if the detected noise is above the operating region of the analog detector or the RF noise detector. These bits indicate that the most recently received data from the sensor input is invalid and should not be used for touch detection. So long as the bit is set for a particular channel, the delta count value is reset to 00h and thus no touch is detected.

These bits are not sticky and will be cleared automatically if the analog block does not report a noise error.

APPLICATION NOTE: If the MTP detection circuitry is enabled, these bits count as sensor inputs above the MTP threshold (see [Section 5.5.4, "Multiple Touch Pattern Detection"](#)) even if the corresponding delta count is not. If the corresponding delta count also exceeds the MTP threshold, it is not counted twice.

APPLICATION NOTE: Regardless of the state of the Noise Status bits, if low frequency noise is detected on a sensor input, that sample will be discarded unless the DIS_ANA_NOISE bit is set. As well, if RF noise is detected on a sensor input, that sample will be discarded unless the DIS_RF_NOISE bit is set.

6.4 Sensor Input Delta Count Registers

TABLE 6-6: SENSOR INPUT DELTA COUNT REGISTERS

ADDR	R/W	Register	B7	B6	B5	B4	B3	B2	B1	B0	Default
10h	R	Sensor Input 1 Delta Count	Sign	64	32	16	8	4	2	1	00h
11h	R	Sensor Input 2 Delta Count	Sign	64	32	16	8	4	2	1	00h
12h	R	Sensor Input 3 Delta Count	Sign	64	32	16	8	4	2	1	00h
13h	R	Sensor Input 4 Delta Count	Sign	64	32	16	8	4	2	1	00h
14h	R	Sensor Input 5 Delta Count	Sign	64	32	16	8	4	2	1	00h
15h	R	Sensor Input 6 Delta Count	Sign	64	32	16	8	4	2	1	00h

The Sensor Input Delta Count registers store the delta count that is compared against the threshold used to determine if a touch has been detected. The count value represents a change in input due to the capacitance associated with a touch on one of the sensor inputs and is referenced to a calibrated base "Not Touched" count value. The delta is an instantaneous change and is updated once per sensor input per sensing cycle (see [Section 5.5.1, "Sensing Cycle"](#)).

The value presented is a standard 2's complement number. In addition, the value is capped at a value of 7Fh. A reading of 7Fh indicates that the sensitivity settings are too high and should be adjusted accordingly (see [Section 6.5](#)).

The value is also capped at a negative value of 80h for negative delta counts which may result upon a release.

6.5 Sensitivity Control Register

TABLE 6-7: SENSITIVITY CONTROL REGISTER

ADDR	R/W	Register	B7	B6	B5	B4	B3	B2	B1	B0	Default
1Fh	R/W	Sensitivity Control	-	DELTA_SENSE[2:0]			BASE_SHIFT[3:0]			2Fh	

CAP1126

The Sensitivity Control register controls the sensitivity of a touch detection.

Bits 6-4 DELTA_SENSE[2:0] - Controls the sensitivity of a touch detection. The sensitivity settings act to scale the relative delta count value higher or lower based on the system parameters. A setting of 000b is the most sensitive while a setting of 111b is the least sensitive. At the more sensitive settings, touches are detected for a smaller delta capacitance corresponding to a “lighter” touch. These settings are more sensitive to noise, however, and a noisy environment may flag more false touches with higher sensitivity levels.

APPLICATION NOTE: A value of 128x is the most sensitive setting available. At the most sensitivity settings, the MSB of the Delta Count register represents 64 out of ~25,000 which corresponds to a touch of approximately 0.25% of the base capacitance (or a ΔC of 25fF from a 10pF base capacitance). Conversely, a value of 1x is the least sensitive setting available. At these settings, the MSB of the Delta Count register corresponds to a delta count of 8192 counts out of ~25,000 which corresponds to a touch of approximately 33% of the base capacitance (or a ΔC of 3.33pF from a 10pF base capacitance).

TABLE 6-8: DELTA_SENSE BIT DECODE

DELTA_SENSE[2:0]			Sensitivity Multiplier
2	1	0	
0	0	0	128x (most sensitive)
0	0	1	64x
0	1	0	32x (default)
0	1	1	16x
1	0	0	8x
1	0	1	4x
1	1	0	2x
1	1	1	1x - (least sensitive)

Bits 3 - 0 - BASE_SHIFT[3:0] - Controls the scaling and data presentation of the Base Count registers. The higher the value of these bits, the larger the range and the lower the resolution of the data presented. The scale factor represents the multiplier to the bit-weighting presented in these register descriptions.

APPLICATION NOTE: The BASE_SHIFT[3:0] bits normally do not need to be updated. These settings will not affect touch detection or sensitivity. These bits are sometimes helpful in analyzing the Cap Sensing board performance and stability.

TABLE 6-9: BASE_SHIFT BIT DECODE

BASE_SHIFT[3:0]				Data Scaling Factor
3	2	1	0	
0	0	0	0	1x
0	0	0	1	2x
0	0	1	0	4x
0	0	1	1	8x
0	1	0	0	16x
0	1	0	1	32x
0	1	1	0	64x
0	1	1	1	128x
1	0	0	0	256x
All others				256x (default = 1111b)

CAP1126

6.6 Configuration Registers

TABLE 6-10: CONFIGURATION REGISTERS

ADDR	R/W	Register	B7	B6	B5	B4	B3	B2	B1	B0	Default
20h	R/W	Configuration	TIMEOUT	WAKE_CFG	DIS_DIG_NOISE	DIS_ANA_NOISE	MAX_DUR_EN	-	-	-	A0h (Rev B) 20h (rev C)
44h	R/W	Configuration 2	INV_LINK_TRAN	ALT_POL	BLK_PWR_CTRL	BLK_POL_MIR	SHOW_RF_NOISE	DIS_RF_NOISE	-	INT_REL_n	40h

The Configuration registers control general global functionality that affects the entire device.

6.6.1 CONFIGURATION - 20H

Bit 7 - TIMEOUT - Enables the timeout and idle functionality of the SMBus protocol.

- '0' (default for Functional Revision C) - The SMBus timeout and idle functionality are disabled. The SMBus interface will not time out if the clock line is held low. Likewise, it will not reset if both the data and clock lines are held high for longer than 200us. This is used for I²C compliance.
- '1' (default for Functional Revision B) - The SMBus timeout and idle functionality are enabled. The SMBus interface will time out if the clock line is held low for longer than 30ms. Likewise, it will reset if both the data and clock lines are held high for longer than 200us.

Bit 6 - WAKE_CFG - Configures the operation of the WAKE pin.

- '0' (default) - The WAKE pin is not asserted when a touch is detected while the device is in Standby. It will still be used to wake the device from Deep Sleep when driven high.
- '1' - The WAKE pin will be asserted high when a touch is detected while the device is in Standby. It will also be used to wake the device from Deep Sleep when driven high.

Bit 5 - DIS_DIG_NOISE - Determines whether the digital noise threshold (see [Section 6.19, "Sensor Input Noise Threshold Register"](#)) is used by the device. Setting this bit disables the feature.

- '0' - The digital noise threshold is used. If a delta count value exceeds the noise threshold but does not exceed the touch threshold, the sample is discarded and not used for the automatic re-calibration routine.
- '1' (default) - The noise threshold is disabled. Any delta count that is less than the touch threshold is used for the automatic re-calibration routine.

Bit 4 - DIS_ANA_NOISE - Determines whether the analog noise filter is enabled. Setting this bit disables the feature.

- '0' (default) - If low frequency noise is detected by the analog block, the delta count on the corresponding channel is set to 0. Note that this does not require that Noise Status bits be set.
- '1' - A touch is not blocked even if low frequency noise is detected.

Bit 3 - MAX_DUR_EN - Determines whether the maximum duration recalibration is enabled.

- '0' (default) - The maximum duration recalibration functionality is disabled. A touch may be held indefinitely and no re-calibration will be performed on any sensor input.
- '1' - The maximum duration recalibration functionality is enabled. If a touch is held for longer than the MAX_DUR bit settings, then the re-calibration routine will be restarted (see [Section 6.8](#)).

6.6.2 CONFIGURATION 2 - 44H

Bit 7 - INV_LINK_TRAN - Determines the behavior of the Linked LED Transition controls (see [Section 6.29](#)).

- '0' (default) - The Linked LED Transition controls set the min duty cycle equal to the max duty cycle.
- '1' - The Linked LED Transition controls will invert the touch signal. For example, a touch signal will be inverted to a non-touched signal.

Bit 6 - ALT_POL - Determines the ALERT# pin polarity and behavior.

- '0' - The ALERT# pin is active high and push-pull.
- '1' (default) - The ALERT# pin is active low and open drain.

CAP1126

Bit 5 - BLK_PWR_CTRL - Determines whether the device will reduce power consumption while waiting between conversion time completion and the end of the polling cycle.

- '0' (default) - The device will always power down as much as possible during the time between the end of the last conversion and the end of the polling cycle.
- '1' - The device will not power down the Cap Sensor during the time between the end of the last conversion and the end of the polling cycle.

Bit 4 - BLK_POL_MIR - Determines whether the LED Mirror Control register bits are linked to the LED Polarity bits. Setting this bit blocks the normal behavior which is to automatically set and clear the LED Mirror Control bits when the LED Polarity bits are set or cleared.

- '0' (default) - When the LED Polarity controls are set, the corresponding LED Mirror control is automatically set. Likewise, when the LED Polarity controls are cleared, the corresponding LED Mirror control is also cleared.
- '1' - When the LED Polarity controls are set, the corresponding LED Mirror control is not automatically set.

Bit 3 - SHOW_RF_NOISE - Determines whether the Noise Status bits will show RF Noise as the only input source.

- '0' (default) - The Noise Status registers will show both RF noise and low frequency EMI noise if either is detected on a capacitive touch sensor input.
- '1' - The Noise Status registers will only show RF noise if it is detected on a capacitive touch sensor input. EMI noise will still be detected and touches will be blocked normally; however, the status bits will not be updated.

Bit 2 - DIS_RF_NOISE - Determines whether the RF noise filter is enabled. Setting this bit disables the feature.

- '0' (default) - If RF noise is detected by the analog block, the delta count on the corresponding channel is set to 0. Note that this does not require that Noise Status bits be set.
- '1' - A touch is not blocked even if RF noise is detected.

Bit 0 - INT_REL_n - Controls the interrupt behavior when a release is detected on a button.

- '0' (default) - An interrupt is generated when a press is detected and again when a release is detected and at the repeat rate (if enabled - see [Section 6.13](#)).
- '1' - An interrupt is generated when a press is detected and at the repeat rate but not when a release is detected.

6.7 Sensor Input Enable Registers

TABLE 6-11: SENSOR INPUT ENABLE REGISTERS

ADDR	R/W	Register	B7	B6	B5	B4	B3	B2	B1	B0	Default
21h	R/W	Sensor Input Enable	-	-	CS6_EN	CS5_EN	CS4_EN	CS3_EN	CS2_EN	CS1_EN	3Fh

The Sensor Input Enable registers determine whether a capacitive touch sensor input is included in the sampling cycle. The length of the sampling cycle is not affected by the number of sensor inputs measured.

Bit 5 - CS6_EN - Enables the CS6 input to be included during the sampling cycle.

- '0' - The CS6 input is not included in the sampling cycle.
- '1' (default) - The CS6 input is included in the sampling cycle.

Bit 4 - CS5_EN - Enables the CS5 input to be included during the sampling cycle.

Bit 3 - CS4_EN - Enables the CS4 input to be included during the sampling cycle.

Bit 2 - CS3_EN - Enables the CS3 input to be included during the sampling cycle.

Bit 1 - CS2_EN - Enables the CS2 input to be included during the sampling cycle.

Bit 0 - CS1_EN - Enables the CS1 input to be included during the sampling cycle.

6.8 Sensor Input Configuration Register

TABLE 6-12: SENSOR INPUT CONFIGURATION REGISTER

ADDR	R/W	Register	B7	B6	B5	B4	B3	B2	B1	B0	Default
22h	R/W	Sensor Input Configuration	MAX_DUR[3:0]				RPT_RATE[3:0]				A4h

CAP1126

The Sensor Input Configuration Register controls timings associated with the Capacitive sensor inputs 1 - 6.

Bits 7 - 4 - MAX_DUR[3:0] - (default 1010b) - Determines the maximum time that a sensor pad is allowed to be touched until the capacitive touch sensor input is recalibrated, as shown in [Table 6-13](#).

TABLE 6-13: MAX_DUR BIT DECODE

MAX_DUR[3:0]				Time Before Recalibration
3	2	1	0	
0	0	0	0	560ms
0	0	0	1	840ms
0	0	1	0	1120ms
0	0	1	1	1400ms
0	1	0	0	1680ms
0	1	0	1	2240ms
0	1	1	0	2800ms
	1	1	1	3360ms
1	0	0	0	3920ms
1	0	0	1	4480ms
1	0	1	0	5600ms (default)
1	0	1	1	6720ms
1	1	0	0	7840ms
1	1	0	1	8906ms
1	1	1	0	10080ms
1	1	1	1	11200ms

Bits 3 - 0 - RPT_RATE[3:0] - (default 0100b) Determines the time duration between interrupt assertions when auto repeat is enabled. The resolution is 35ms the range is from 35ms to 560ms as shown in [Table 6-14](#).

TABLE 6-14: RPT_RATE BIT DECODE

RPT_RATE[3:0]				Interrupt Repeat RATE
3	2	1	0	
0	0	0	0	35ms
0	0	0	1	70ms
0	0	1	0	105ms
0	0	1	1	140ms
0	1	0	0	175ms (default)
0	1	0	1	210ms
0	1	1	0	245ms
0	1	1	1	280ms
1	0	0	0	315ms
1	0	0	1	350ms
1	0	1	0	385ms
1	0	1	1	420ms
1	1	0	0	455ms
1	1	0	1	490ms
1	1	1	0	525ms
1	1	1	1	560ms

CAP1126

6.9 Sensor Input Configuration 2 Register

TABLE 6-15: SENSOR INPUT CONFIGURATION 2 REGISTER

ADDR	R/W	Register	B7	B6	B5	B4	B3	B2	B1	B0	Default
23h	R/W	Sensor Input Configuration 2	-	-	-	-	M_PRESS[3:0]			07h	

Bits 3 - 0 - M_PRESS[3:0] - (default 0111b) - Determines the minimum amount of time that sensor inputs configured to use auto repeat must detect a sensor pad touch to detect a “press and hold” event. If the sensor input detects a touch for longer than the M_PRESS[3:0] settings, a “press and hold” event is detected. If a sensor input detects a touch for less than or equal to the M_PRESS[3:0] settings, a touch event is detected.

The resolution is 35ms the range is from 35ms to 560ms as shown in [Table 6-16](#).

TABLE 6-16: M_PRESS BIT DECODE

M_PRESS[3:0]				M_PRESS SETTINGS
3	2	1	0	
0	0	0	0	35ms
0	0	0	1	70ms
0	0	1	0	105ms
0	0	1	1	140ms
0	1	0	0	175ms
0	1	0	1	210ms
0	1	1	0	245ms
0	1	1	1	280ms (default)
1	0	0	0	315ms
1	0	0	1	350ms
1	0	1	0	385ms
1	0	1	1	420ms
1	1	0	0	455ms
1	1	0	1	490ms
1	1	1	0	525ms
1	1	1	1	560ms

6.10 Averaging and Sampling Configuration Register

TABLE 6-17: AVERAGING AND SAMPLING CONFIGURATION REGISTER

ADDR	R/W	Register	B7	B6	B5	B4	B3	B2	B1	B0	Default
24h	R/W	Averaging and Sampling Config		AVG[2:0]			SAMP_TIME[1:0]		CYCLE_TIME [1:0]		39h

The Averaging and Sampling Configuration register controls the number of samples taken and the total sensor input cycle time for all active sensor inputs while the device is functioning in Active state.

Bits 6 - 4 - AVG[2:0] - Determines the number of samples that are taken for all active channels during the sensor cycle as shown in [Table 6-18](#). All samples are taken consecutively on the same channel before the next channel is sampled and the result is averaged over the number of samples measured before updating the measured results.

For example, if CS1, CS2, and CS3 are sampled during the sensor cycle, and the AVG[2:0] bits are set to take 4 samples per channel, then the full sensor cycle will be: CS1, CS1, CS1, CS1, CS2, CS2, CS2, CS2, CS3, CS3, CS3, CS3.

CAP1126

TABLE 6-18: AVG BIT DECODE

AVG[2:0]			Number of Samples Taken per Measurement
2	1	0	
0	0	0	1
0	0	1	2
0	1	0	4
0	1	1	8 (default)
1	0	0	16
1	0	1	32
1	1	0	64
1	1	1	128

Bits 3 - 2 - SAMP_TIME[1:0] - Determines the time to take a single sample as shown in [Table 6-19](#).

TABLE 6-19: SAMP_TIME BIT DECODE

SAMP_TIME[1:0]		Sample Time
1	0	
0	0	320us
0	1	640us
1	0	1.28ms (default)
1	1	2.56ms

Bits 1 - 0 - CYCLE_TIME[1:0] - Determines the overall cycle time for all measured channels during normal operation as shown in [Table 6-20](#). All measured channels are sampled at the beginning of the cycle time. If additional time is remaining, then the device is placed into a lower power state for the remaining duration of the cycle.

TABLE 6-20: CYCLE_TIME BIT DECODE

CYCLE_TIME[1:0]		Overall Cycle Time
1	0	
0	0	35ms
0	1	70ms (default)
1	0	105ms
1	1	140ms

APPLICATION NOTE: The programmed cycle time is only maintained if the total averaging time for all samples is less than the programmed cycle. The AVG[2:0] bits will take priority so that if more samples are required than would normally be allowed during the cycle time, the cycle time will be extended as necessary to accommodate the number of samples to be measured.

6.11 Calibration Activate Register

TABLE 6-21: CALIBRATION ACTIVATE REGISTER

ADDR	R/W	Register	B7	B6	B5	B4	B3	B2	B1	B0	Default
26h	R/W	Calibration Activate	-	-	CS6_ CAL	CS5_ CAL	CS4_ CAL	CS3_ CAL	CS2_ CAL	CS1_ CAL	00h

The Calibration Activate register forces the respective sensor inputs to be re-calibrated affecting both the analog and digital blocks. During the re-calibration routine, the sensor inputs will not detect a press for up to 600ms and the Sensor Input Base Count register values will be invalid. During this time, any press on the corresponding sensor pads will invalidate the re-calibration. When finished, the CALX[9:0] bits will be updated (see [Section 6.39](#)).

CAP1126

When the corresponding bit is set, the device will perform the calibration and the bit will be automatically cleared once the re-calibration routine has finished.

Bit 5 - CS6_CAL - When set, the CS6 input is re-calibrated. This bit is automatically cleared once the sensor input has been re-calibrated successfully.

Bit 4 - CS5_CAL - When set, the CS5 input is re-calibrated. This bit is automatically cleared once the sensor input has been re-calibrated successfully.

Bit 3 - CS4_CAL - When set, the CS4 input is re-calibrated. This bit is automatically cleared once the sensor input has been re-calibrated successfully.

Bit 2 - CS3_CAL - When set, the CS3 input is re-calibrated. This bit is automatically cleared once the sensor input has been re-calibrated successfully.

Bit 1 - CS2_CAL - When set, the CS2 input is re-calibrated. This bit is automatically cleared once the sensor input has been re-calibrated successfully.

Bit 0 - CS1_CAL - When set, the CS1 input is re-calibrated. This bit is automatically cleared once the sensor input has been re-calibrated successfully.

6.12 Interrupt Enable Register

TABLE 6-22: INTERRUPT ENABLE REGISTER

ADDR	R/W	Register	B7	B6	B5	B4	B3	B2	B1	B0	Default
27h	R/W	Interrupt Enable	-	-	CS6_INT_EN	CS5_INT_EN	CS4_INT_EN	CS3_INT_EN	CS2_INT_EN	CS1_INT_EN	3Fh

The Interrupt Enable register determines whether a sensor pad touch or release (if enabled) causes the interrupt pin to be asserted.

Bit 5 - CS6_INT_EN - Enables the interrupt pin to be asserted if a touch is detected on CS6 (associated with the CS6 status bit).

- '0' - The interrupt pin will not be asserted if a touch is detected on CS6 (associated with the CS6 status bit).
- '1' (default) - The interrupt pin will be asserted if a touch is detected on CS6 (associated with the CS6 status bit).

Bit 4 - CS5_INT_EN - Enables the interrupt pin to be asserted if a touch is detected on CS5 (associated with the CS5 status bit).

Bit 3 - CS4_INT_EN - Enables the interrupt pin to be asserted if a touch is detected on CS4 (associated with the CS4 status bit).

Bit 2 - CS3_INT_EN - Enables the interrupt pin to be asserted if a touch is detected on CS3 (associated with the CS3 status bit).

Bit 1 - CS2_INT_EN - Enables the interrupt pin to be asserted if a touch is detected on CS2 (associated with the CS2 status bit).

Bit 0 - CS1_INT_EN - Enables the interrupt pin to be asserted if a touch is detected on CS1 (associated with the CS1 status bit).

6.13 Repeat Rate Enable Register

TABLE 6-23: REPEAT RATE ENABLE REGISTER

ADDR	R/W	Register	B7	B6	B5	B4	B3	B2	B1	B0	Default
28h	R/W	Repeat Rate Enable	-	-	CS6_RPT_EN	CS5_RPT_EN	CS4_RPT_EN	CS3_RPT_EN	CS2_RPT_EN	CS1_RPT_EN	3Fh

The Repeat Rate Enable register enables the repeat rate of the sensor inputs as described in [Section 5.6.1](#).

Bit 5 - CS6_RPT_EN - Enables the repeat rate for capacitive touch sensor input 6.

- '0' - The repeat rate for CS6 is disabled. It will only generate an interrupt when a touch is detected and when a release is detected no matter how long the touch is held for.
- '1' (default) - The repeat rate for CS6 is enabled. In the case of a "touch" event, it will generate an interrupt when a

CAP1126

touch is detected and a release is detected (as determined by the INT_REL_n bit - see [Section 6.6](#)). In the case of a “press and hold” event, it will generate an interrupt when a touch is detected and at the repeat rate so long as the touch is held.

Bit 4 - CS5_RPT_EN - Enables the repeat rate for capacitive touch sensor input 5.

Bit 3 - CS4_RPT_EN - Enables the repeat rate for capacitive touch sensor input 4.

Bit 2 - CS3_RPT_EN - Enables the repeat rate for capacitive touch sensor input 3.

Bit 1 - CS2_RPT_EN - Enables the repeat rate for capacitive touch sensor input 2.

Bit 0 - CS1_RPT_EN - Enables the repeat rate for capacitive touch sensor input 1.

6.14 Multiple Touch Configuration Register

TABLE 6-24: MULTIPLE TOUCH CONFIGURATION

ADDR	R/W	Register	B7	B6	B5	B4	B3	B2	B1	B0	Default
2Ah	R/W	Multiple Touch Config	MULT_BLK_EN	-	-	-	B_MULT_T[1:0]		-	-	80h

The Multiple Touch Configuration register controls the settings for the multiple touch detection circuitry. These settings determine the number of simultaneous buttons that may be pressed before additional buttons are blocked and the MULT status bit is set.

Bit 7 - MULT_BLK_EN - Enables the multiple button blocking circuitry.

- ‘0’ - The multiple touch circuitry is disabled. The device will not block multiple touches.
- ‘1’ (default) - The multiple touch circuitry is enabled. The device will flag the number of touches equal to programmed multiple touch threshold and block all others. It will remember which sensor inputs are valid and block all others until that sensor pad has been released. Once a sensor pad has been released, the N detected touches (determined via the cycle order of CS1 - CS6) will be flagged and all others blocked.

Bits 3 - 2 - B_MULT_T[1:0] - Determines the number of simultaneous touches on all sensor pads before a Multiple Touch Event is detected and sensor inputs are blocked. The bit decode is given by [Table 6-25](#).

TABLE 6-25: B_MULT_T BIT DECODE

B_MULT_T[1:0]		Number of Simultaneous Touches
1	0	
0	0	1 (default)
0	1	2
1	0	3
1	1	4

6.15 Multiple Touch Pattern Configuration Register

TABLE 6-26: MULTIPLE TOUCH PATTERN CONFIGURATION

ADDR	R/W	Register	B7	B6	B5	B4	B3	B2	B1	B0	Default
2Bh	R/W	Multiple Touch Pattern Config	MTP_EN	-	-		MTP_TH[1:0]		COMP_PTRN	MTP_ALERT	00h

The Multiple Touch Pattern Configuration register controls the settings for the multiple touch pattern detection circuitry. This circuitry works like the multiple touch detection circuitry with the following differences:

1. The detection threshold is a percentage of the touch detection threshold as defined by the MTP_TH[1:0] bits whereas the multiple touch circuitry uses the touch detection threshold.
2. The MTP detection circuitry either will detect a specific pattern of sensor inputs as determined by the Multiple Touch Pattern register settings or it will use the Multiple Touch Pattern register settings to determine a minimum number of sensor inputs that will cause the MTP circuitry to flag an event. When using pattern recognition mode,

if all of the sensor inputs set by the Multiple Touch Pattern register have a delta count greater than the MTP threshold or have their corresponding Noise Flag Status bits set, the MTP bit will be set. When using the absolute number mode, if the number of sensor inputs with thresholds above the MTP threshold or with Noise Flag Status bits set is equal to or greater than this number, the MTP bit will be set.

3. When an MTP event occurs, all touches are blocked and an interrupt is generated.
4. All sensor inputs will remain blocked so long as the requisite number of sensor inputs are above the MTP threshold or have Noise Flag Status bits set. Once this condition is removed, touch detection will be restored. Note that the MTP status bit is only cleared by writing a '0' to the INT bit once the condition has been removed.

Bit 7 - MTP_EN - Enables the multiple touch pattern detection circuitry.

- '0' (default) - The MTP detection circuitry is disabled.
- '1' - The MTP detection circuitry is enabled.

Bits 3-2 - MTP_TH[1:0] - Determine the MTP threshold, as shown in [Table 6-27](#). This threshold is a percentage of sensor input threshold (see [Section 6.18, "Sensor Input Threshold Registers"](#)) when the device is in the Fully Active state or of the standby threshold (see [Section 6.23, "Standby Threshold Register"](#)) when the device is in the Standby state.

TABLE 6-27: MTP_TH BIT DECODE

MTP_TH[1:0]		Threshold Divide Setting
1	0	
0	0	12.5% (default)
0	1	25%
1	0	37.5%
1	1	100%

Bit 1 - COMP_PTRN - Determines whether the MTP detection circuitry will use the Multiple Touch Pattern register as a specific pattern of sensor inputs or as an absolute number of sensor inputs.

- '0' (default) - The MTP detection circuitry will use the Multiple Touch Pattern register bit settings as an absolute minimum number of sensor inputs that must be above the threshold or have Noise Flag Status bits set. The number will be equal to the number of bits set in the register.
- '1' - The MTP detection circuitry will use pattern recognition. Each bit set in the Multiple Touch Pattern register indicates a specific sensor input that must have a delta count greater than the MTP threshold or have a Noise Flag Status bit set. If the criteria are met, the MTP status bit will be set.

Bit 0 - MTP_ALERT - Enables an interrupt if an MTP event occurs. In either condition, the MTP status bit will be set.

- '0' (default) - If an MTP event occurs, the ALERT# pin is not asserted.
- '1' - If an MTP event occurs, the ALERT# pin will be asserted.

6.16 Multiple Touch Pattern Register

TABLE 6-28: MULTIPLE TOUCH PATTERN REGISTER

ADDR	R/W	Register	B7	B6	B5	B4	B3	B2	B1	B0	Default
2Dh	R/W	Multiple Touch Pattern	-	-	CS6_PTRN	CS5_PTRN	CS4_PTRN	CS3_PTRN	CS2_PTRN	CS1_PTRN	3Fh

The Multiple Touch Pattern register acts as a pattern to identify an expected sensor input profile for diagnostics or other significant events. There are two methods for how the Multiple Touch Pattern register is used: as specific sensor inputs or number of sensor input that must exceed the MTP threshold or have Noise Flag Status bits set. Which method is used is based on the COMP_PTRN bit (see [Section 6.15](#)). The methods are described below.

1. **Specific Sensor Inputs:** If, during a single polling cycle, the specific sensor inputs above the MTP threshold or with Noise Flag Status bits set match those bits set in the Multiple Touch Pattern register, an MTP event is flagged.
2. **Number of Sensor Inputs:** If, during a single polling cycle, the number of sensor inputs with a delta count above the MTP threshold or with Noise Flag Status bits set is equal to or greater than the number of pattern bits set, an MTP event is flagged.

CAP1126

Bit 5 - CS6_PTRN - Determines whether CS6 is considered as part of the Multiple Touch Pattern.

- '0' - CS6 is not considered a part of the pattern.
- '1' - CS6 is considered a part of the pattern or the absolute number of sensor inputs that must have a delta count greater than the MTP threshold or have the Noise Flag Status bit set is increased by 1.

Bit 4 - CS5_PTRN - Determines whether CS5 is considered as part of the Multiple Touch Pattern.

Bit 3 - CS4_PTRN - Determines whether CS4 is considered as part of the Multiple Touch Pattern.

Bit 2 - CS3_PTRN - Determines whether CS3 is considered as part of the Multiple Touch Pattern.

Bit 1 - CS2_PTRN - Determines whether CS2 is considered as part of the Multiple Touch Pattern.

Bit 0 - CS1_PTRN - Determines whether CS1 is considered as part of the Multiple Touch Pattern.

6.17 Recalibration Configuration Register

TABLE 6-29: RECALIBRATION CONFIGURATION REGISTERS

ADDR	R/W	Register	B7	B6	B5	B4	B3	B2	B1	B0	Default
2Fh	R/W	Recalibration Configuration	BUT_LD_TH	NO_CLR_INTD	NO_CLR_NEG	NEG_DELTA_CNT[1:0]		CAL_CFG[2:0]			8Ah

The Recalibration Configuration register controls the automatic re-calibration routine settings as well as advanced controls to program the Sensor Input Threshold register settings.

Bit 7 - BUT_LD_TH - Enables setting all Sensor Input Threshold registers by writing to the Sensor Input 1 Threshold register.

- '0' - Each Sensor Input X Threshold register is updated individually.
- '1' (default) - Writing the Sensor Input 1 Threshold register will automatically overwrite the Sensor Input Threshold registers for all sensor inputs (Sensor Input Threshold 1 through Sensor Input Threshold 6). The individual Sensor Input X Threshold registers (Sensor Input 2 Threshold through Sensor Input 6 Threshold) can be individually updated at any time.

Bit 6 - NO_CLR_INTD - Controls whether the accumulation of intermediate data is cleared if the noise status bit is set.

- '0' (default) - The accumulation of intermediate data is cleared if the noise status bit is set.
- '1' - The accumulation of intermediate data is not cleared if the noise status bit is set.

APPLICATION NOTE: Bits 5 and 6 should both be set to the same value. Either both should be set to '0' or both should be set to '1'.

Bit 5 - NO_CLR_NEG - Controls whether the consecutive negative delta counts counter is cleared if the noise status bit is set.

- '0' (default) - The consecutive negative delta counts counter is cleared if the noise status bit is set.
- '1' - The consecutive negative delta counts counter is not cleared if the noise status bit is set.

Bits 4 - 3 - NEG_DELTA_CNT[1:0] - Determines the number of negative delta counts necessary to trigger a digital recalibration as shown in [Table 6-30](#).

TABLE 6-30: NEG_DELTA_CNT BIT DECODE

NEG_DELTA_CNT[1:0]		Number of Consecutive Negative Delta Count Values
1	0	
0	0	8
0	1	16 (default)
1	0	32
1	1	None (disabled)

CAP1126

Bits 2 - 0 - CAL_CFG[2:0] - Determines the update time and number of samples of the automatic re-calibration routine. The settings apply to all sensor inputs universally (though individual sensor inputs can be configured to support re-calibration - see [Section 6.11](#)).

TABLE 6-31: CAL_CFG BIT DECODE

CAL_CFG[2:0]			Recalibration Samples (see Note 6-1)	Update Time (see Note 6-2)
2	1	0		
0	0	0	16	16
0	0	1	32	32
0	1	0	64	64 (default)
0	1	1	128	128
1	0	0	256	256
1	0	1	256	1024
1	1	0	256	2048
1	1	1	256	4096

Note 6-1 Recalibration Samples refers to the number of samples that are measured and averaged before the Base Count is updated however does not control the base count update period.

Note 6-2 Update Time refers to the amount of time (in polling cycle periods) that elapses before the Base Count is updated. The time will depend upon the number of channels active, the averaging setting, and the programmed cycle time.

6.18 Sensor Input Threshold Registers

TABLE 6-32: SENSOR INPUT THRESHOLD REGISTERS

ADDR	R/W	Register	B7	B6	B5	B4	B3	B2	B1	B0	Default
30h	R/W	Sensor Input 1 Threshold	-	64	32	16	8	4	2	1	40h
31h	R/W	Sensor Input 2 Threshold	-	64	32	16	8	4	2	1	40h
32h	R/W	Sensor Input 3 Threshold	-	64	32	16	8	4	2	1	40h
33h	R/W	Sensor Input 4 Threshold	-	64	32	16	8	4	2	1	40h
34h	R/W	Sensor Input 5 Threshold	-	64	32	16	8	4	2	1	40h
35h	R/W	Sensor Input 6 Threshold	-	64	32	16	8	4	2	1	40h

The Sensor Input Threshold registers store the delta threshold that is used to determine if a touch has been detected. When a touch occurs, the input signal of the corresponding sensor pad changes due to the capacitance associated with a touch. If the sensor input change exceeds the threshold settings, a touch is detected.

When the BUT_LD_TH bit is set (see [Section 6.17](#) - bit 7), writing data to the Sensor Input 1 Threshold register will update all of the sensor input threshold registers (31h - 35h inclusive).

6.19 Sensor Input Noise Threshold Register

TABLE 6-33: SENSOR INPUT NOISE THRESHOLD REGISTER

ADDR	R/W	Register	B7	B6	B5	B4	B3	B2	B1	B0	Default
38h	R/W	Sensor Input Noise Threshold							CS_BN_TH [1:0]		01h

CAP1126

The Sensor Input Noise Threshold register controls the value of a secondary internal threshold to detect noise and improve the automatic recalibration routine. If a capacitive touch sensor input exceeds the Sensor Input Noise Threshold but does not exceed the sensor input threshold, it is determined to be caused by a noise spike. That sample is not used by the automatic re-calibration routine. This feature can be disabled by setting the DIS_DIG_NOISE bit.

Bits 1-0 - CS1_BN_TH[1:0] - Controls the noise threshold for all capacitive touch sensor inputs, as shown in Table 6-34. The threshold is proportional to the threshold setting.

TABLE 6-34: CSX_BN_TH BIT DECODE

CS_BN_TH[1:0]		Percent Threshold Setting
1	0	
0	0	25%
0	1	37.5% (default)
1	0	50%
1	1	62.5%

6.20 Standby Channel Register

TABLE 6-35: STANDBY CHANNEL REGISTER

ADDR	R/W	Register	B7	B6	B5	B4	B3	B2	B1	B0	Default
40h	R/W	Standby Channel	-	-	CS6_STBY	CS5_STBY	CS4_STBY	CS3_STBY	CS2_STBY	CS1_STBY	00h

The Standby Channel register controls which (if any) capacitive touch sensor inputs are active during Standby.

Bit 5 - CS6_STBY - Controls whether the CS6 channel is active in Standby.

- '0' (default) - The CS6 channel not be sampled during Standby mode.
- '1' - The CS6 channel will be sampled during Standby Mode. It will use the Standby threshold setting, and the standby averaging and sensitivity settings.

Bit 4 - CS5_STBY - Controls whether the CS5 channel is active in Standby.

Bit 3 - CS4_STBY - Controls whether the CS4 channel is active in Standby.

Bit 2 - CS3_STBY - Controls whether the CS3 channel is active in Standby.

Bit 1 - CS2_STBY - Controls whether the CS2 channel is active in Standby.

Bit 0 - CS1_STBY - Controls whether the CS1 channel is active in Standby.

6.21 Standby Configuration Register

TABLE 6-36: STANDBY CONFIGURATION REGISTER

ADDR	R/W	Register	B7	B6	B5	B4	B3	B2	B1	B0	Default
41h	R/W	Standby Configuration	AVG_SUM	STBY_AVG[2:0]		STBY_SAMP_TIME[1:0]		STBY_CY_TIME[1:0]			39h

The Standby Configuration register controls averaging and cycle time for those sensor inputs that are active in Standby. This register is useful for detecting proximity on a small number of sensor inputs as it allows the user to change averaging and sample times on a limited number of sensor inputs and still maintain normal functionality in the fully active state.

Bit 7 - AVG_SUM - Determines whether the active sensor inputs will average the programmed number of samples or whether they will accumulate for the programmed number of samples.

- '0' - (default) - The active sensor input delta count values will be based on the average of the programmed number of samples when compared against the threshold.
- '1' - The active sensor input delta count values will be based on the summation of the programmed number of samples when compared against the threshold. This bit should only be set when performing proximity detection as

CAP1126

a physical touch will overflow the delta count registers and may result in false readings.

Bits 6 - 4 - STBY_AVG[2:0] - Determines the number of samples that are taken for all active channels during the sensor cycle as shown in [Table 6-37](#). All samples are taken consecutively on the same channel before the next channel is sampled and the result is averaged over the number of samples measured before updating the measured results.

TABLE 6-37: STBY_AVG BIT DECODE

STBY_AVG[2:0]			Number of Samples Taken per Measurement
2	1	0	
0	0	0	1
0	0	1	2
0	1	0	4
0	1	1	8 (default)
1	0	0	16
1	0	1	32
1	1	0	64
1	1	1	128

Bit 3-2 - STBY_SAMP_TIME[1:0] - Determines the time to take a single sample when the device is in Standby as shown in [Table 6-38](#).

TABLE 6-38: STBY_SAMP_TIME BIT DECODE

STBY_SAMP_TIME[1:0]		Sampling Time
1	0	
0	0	320us
0	1	640us
1	0	1.28ms (default)
1	1	2.56ms

Bits 1 - 0 - STBY_CY_TIME[2:0] - Determines the overall cycle time for all measured channels during standby operation as shown in [Table 6-39](#). All measured channels are sampled at the beginning of the cycle time. If additional time is remaining, the device is placed into a lower power state for the remaining duration of the cycle.

TABLE 6-39: STBY_CY_TIME BIT DECODE

STBY_CY_TIME[1:0]		Overall Cycle Time
1	0	
0	0	35ms
0	1	70ms (default)
1	0	105ms
1	1	140ms

APPLICATION NOTE: The programmed cycle time is only maintained if the total averaging time for all samples is less than the programmed cycle. The STBY_AVG[2:0] bits will take priority so that if more samples are required than would normally be allowed during the cycle time, the cycle time will be extended as necessary to accommodate the number of samples to be measured.

CAP1126

6.22 Standby Sensitivity Register

TABLE 6-40: STANDBY SENSITIVITY REGISTER

ADDR	R/W	Register	B7	B6	B5	B4	B3	B2	B1	B0	Default
42h	R/W	Standby Sensitivity	-	-	-	-	-	STBY_SENSE[2:0]			02h

The Standby Sensitivity register controls the sensitivity for sensor inputs that are active in Standby.

Bits 2 - 0 - STBY_SENSE[2:0] - Controls the sensitivity for sensor inputs that are active in Standby. The sensitivity settings act to scale the relative delta count value higher or lower based on the system parameters. A setting of 000b is the most sensitive while a setting of 111b is the least sensitive. At the more sensitive settings, touches are detected for a smaller delta C corresponding to a “lighter” touch. These settings are more sensitive to noise however and a noisy environment may flag more false touches than higher sensitivity levels.

APPLICATION NOTE: A value of 128x is the most sensitive setting available. At the most sensitivity settings, the MSB of the Delta Count register represents 64 out of ~25,000 which corresponds to a touch of approximately 0.25% of the base capacitance (or a ΔC of 25fF from a 10pF base capacitance). Conversely a value of 1x is the least sensitive setting available. At these settings, the MSB of the Delta Count register corresponds to a delta count of 8192 counts out of ~25,000 which corresponds to a touch of approximately 33% of the base capacitance (or a ΔC of 3.33pF from a 10pF base capacitance).

TABLE 6-41: STBY_SENSE BIT DECODE

STBY_SENSE[2:0]			Sensitivity Multiplier
2	1	0	
0	0	0	128x (most sensitive)
0	0	1	64x
0	1	0	32x (default)
0	1	1	16x
1	0	0	8x
1	0	1	4x
1	1	0	2x
1	1	1	1x - (least sensitive)

6.23 Standby Threshold Register

TABLE 6-42: STANDBY THRESHOLD REGISTER

ADDR	R/W	Register	B7	B6	B5	B4	B3	B2	B1	B0	Default
43h	R/W	Standby Threshold	-	64	32	16	8	4	2	1	40h

The Standby Threshold register stores the delta threshold that is used to determine if a touch has been detected. When a touch occurs, the input signal of the corresponding sensor pad changes due to the capacitance associated with a touch. If the sensor input change exceeds the threshold settings, a touch is detected.

6.24 Sensor Input Base Count Registers

TABLE 6-43: SENSOR INPUT BASE COUNT REGISTERS

ADDR	R/W	Register	B7	B6	B5	B4	B3	B2	B1	B0	Default
50h	R	Sensor Input 1 Base Count	128	64	32	16	8	4	2	1	C8h

CAP1126

TABLE 6-43: SENSOR INPUT BASE COUNT REGISTERS (CONTINUED)

ADDR	R/W	Register	B7	B6	B5	B4	B3	B2	B1	B0	Default
51h	R	Sensor Input 2 Base Count	128	64	32	16	8	4	2	1	C8h
52h	R	Sensor Input 3 Base Count	128	64	32	16	8	4	2	1	C8h
53h	R	Sensor Input 4 Base Count	128	64	32	16	8	4	2	1	C8h
54h	R	Sensor Input 5 Base Count	128	64	32	16	8	4	2	1	C8h
55h	R	Sensor Input 6 Base Count	128	64	32	16	8	4	2	1	C8h

The Sensor Input Base Count registers store the calibrated “Not Touched” input value from the capacitive touch sensor inputs. These registers are periodically updated by the re-calibration routine.

The routine uses an internal adder to add the current count value for each reading to the sum of the previous readings until sample size has been reached. At this point, the upper 16 bits are taken and used as the Sensor Input Base Count. The internal adder is then reset and the re-calibration routine continues.

The data presented is determined by the BASE_SHIFT[3:0] bits (see [Section 6.5](#)).

6.25 LED Output Type Register

TABLE 6-44: LED OUTPUT TYPE REGISTER

ADDR	R/W	Register	B7	B6	B5	B4	B3	B2	B1	B0	Default
71h	R/W	LED Output Type	-	-	-	-	-	-	LED2_OT	LED1_OT	00h

The LED Output Type register controls the type of output for the LED pins. Each pin is controlled by a single bit. Refer to application note 21.4 CAP1126Family LED Configuration Options for more information about implementing LEDs.

Bit 1 - LED2_OT - Determines the output type of the LED2 pin.

- ‘0’ (default) - The LED2 pin is an open-drain output with an external pull-up resistor. When the appropriate pin is set to the “active” state (logic ‘1’), the pin will be driven low. Conversely, when the pin is set to the “inactive” state (logic ‘0’), then the pin will be left in a High Z state and pulled high via an external pull-up resistor.
- ‘1’ - The LED2 pin is a push-pull output. When driving a logic ‘1’, the pin is driven high. When driving a logic ‘0’, the pin is driven low.

Bit 0 - LED1_OT - Determines the output type of the LED1 pin.

6.26 Sensor Input LED Linking Register

TABLE 6-45: SENSOR INPUT LED LINKING REGISTER

ADDR	R/W	Register	B7	B6	B5	B4	B3	B2	B1	B0	Default
72h	R/W	Sensor Input LED Linking	-	-	-	-	-	-	CS2_LED2	CS1_LED1	00h

The Sensor Input LED Linking register controls whether a capacitive touch sensor input is linked to an LED output. If the corresponding bit is set, then the appropriate LED output will change states defined by the LED Behavior controls (see [Section 6.31](#)) in response to the capacitive touch sensor input.

Bit 1 - CS2_LED2 - Links the LED2 output to a detected touch on the CS2 sensor input. When a touch is detected, the LED is actuated and will behave as determined by the LED Behavior controls.

- ‘0’ (default) - The LED 2 output is not associated with the CS2 input. If a touch is detected on the CS2 input, the LED will not automatically be actuated. The LED is enabled and controlled via the LED Output Control register (see [Section 6.28](#)) and the LED Behavior registers (see [Section 6.31](#)).

CAP1126

- '1' - The LED 2 output is associated with the CS2 input. If a touch is detected on the CS2 input, the LED will be actuated and behave as defined in [Table 6-52](#).

Bit 0 - CS1_LED1 - Links the LED1 output to a detected touch on the CS1 sensor input. When a touch is detected, the LED is actuated and will behave as determined by the LED Behavior controls.

6.27 LED Polarity Register

TABLE 6-46: LED POLARITY REGISTER

ADDR	R/W	Register	B7	B6	B5	B4	B3	B2	B1	B0	Default
73h	R/W	LED Polarity	-	-	-	-	-	-	LED2_ POL	LED1_ POL	00h

The LED Polarity register controls the logical polarity of the LED outputs. When these bits are set or cleared, the corresponding LED Mirror controls are also set or cleared (unless the BLK_POL_MIR bit is set - see [Section 6.6, "Configuration Registers"](#)). [Table 6-48, "LED Polarity Behavior"](#) shows the interaction between the polarity controls, output controls, and relative brightness.

APPLICATION NOTE: The polarity controls determine the final LED pin drive. A touch on a linked capacitive touch sensor input is treated in the same way as the LED Output Control bit being set to a logic '1'.

APPLICATION NOTE: The LED drive assumes that the LEDs are configured such that if the LED pin is driven to a logic '0' then the LED will be on and that the CAP1126 LED pin is sinking the LED current. Conversely, if the LED pin is driven to a logic '1', the LED will be off and there is no current flow. See [Figure 5-1, "System Diagram for CAP1126"](#).

APPLICATION NOTE: This application note applies when the LED polarity is inverted (LEDx_POL = '0'). For LED operation, the duty cycle settings determine the % of time that the LED pin will be driven to a logic '0' state in. The Max Duty Cycle settings define the maximum % of time that the LED pin will be driven low (i.e. maximum % of time that the LED is **on**) while the Min Duty Cycle settings determine the minimum % of time that the LED pin will be driven low (i.e. minimum % of time that the LED is **on**). When there is no touch detected or the LED Output Control register bit is at a logic '0', the LED output will be driven at the minimum duty cycle setting. Breathe operations will ramp the duty cycle from the minimum duty cycle to the maximum duty cycle.

APPLICATION NOTE: This application note applies when the LED polarity is non-inverted (LEDx_POL = '1'). For LED operation, the duty cycle settings determine the % of time that the LED pin will be driven to a logic '1' state. The Max Duty Cycle settings define the maximum % of time that the LED pin will be driven high (i.e. maximum % of time that the LED is **off**) while the Min Duty Cycle settings determine the minimum % of time that the LED pin will be driven high (i.e. minimum % of time that the LED is **off**). When there is no touch detected or the LED Output Control register bit is at a logic '0', the LED output will be driven at 100 minus the minimum duty cycle setting. Breathe operations will ramp the duty cycle from 100 minus the minimum duty cycle to 100 minus the maximum duty cycle.

APPLICATION NOTE: The LED Mirror controls (see [Section 6.30, "LED Mirror Control Register"](#)) work with the polarity controls with respect to LED brightness but will not have a direct effect on the output pin drive.

Bit 1 - LED2_POL - Determines the polarity of the LED2 output.

- '0' (default) - The LED2 output is inverted. For example, a setting of '1' in the LED Output Control register will cause the LED pin output to be driven to a logic '0'.
- '1' - The LED2 output is non-inverted. For example, a setting of '1' in the LED Output Control register will cause the LED pin output to be driven to a logic '1' or left in the high-z state as determined by its output type.

Bit 0 - LED1_POL - Determines the polarity of the LED1 output.

CAP1126

6.28 LED Output Control Register

TABLE 6-47: LED OUTPUT CONTROL REGISTER

ADDR	R/W	Register	B7	B6	B5	B4	B3	B2	B1	B0	Default
74h	R/W	LED Output Control	-	-	-	-	-	-	LED2_DR	LED1_DR	00h

The LED Output Control Register controls the output state of the LED pins that are not linked to sensor inputs.

Note: If an LED is linked to a sensor input in the Sensor Input LED Linking Register ([Section 6.26, "Sensor Input LED Linking Register"](#)), the corresponding bit in the LED Output Control Register is ignored (i.e. a linked LED cannot be host controlled).

The LED Polarity Control Register will determine the non actuated state of the LED pins. The actuated LED behavior is determined by the LED behavior controls (see [Section 6.31, "LED Behavior Register"](#)).

[Table 6-48](#) shows the interaction between the polarity controls, output controls, and relative brightness.

Bit 1 - LED2_DR - Determines whether LED2 output is driven high or low.

- '0' (default) - The LED2 output is driven at the minimum duty cycle or not actuated.
- '1' - The LED2 output is High Z or driven at the maximum duty cycle or actuated.

Bit 0 - LED1_DR - Determines whether LED1 output is driven high or low.

TABLE 6-48: LED POLARITY BEHAVIOR

LED Output Control Register or Touch	Polarity	Max Duty	Min Duty	Brightness	LED Appearance
0	inverted ('0')	not used	minimum % of time that the LED is on (logic 0)	maximum brightness at min duty cycle	on at min duty cycle
1	inverted ('0')	maximum % of time that the LED is on (logic 0)	minimum % of time that the LED is on (logic 0)	maximum brightness at max duty cycle. Brightness ramps from min duty cycle to max duty cycle	according to LED behavior
0	non-inverted ('1')	not used	minimum % of time that the LED is off (logic 1)	maximum brightness at 100 minus min duty cycle.	on at 100 - min duty cycle
1	non-inverted ('1')	maximum % of time that the LED is off (logic 1)	minimum % of time that the LED is off (logic 1)	For Direct behavior, maximum brightness is 100 minus max duty cycle. When breathing, max brightness is 100 minus min duty cycle. Brightness ramps from 100 - min duty cycle to 100 - max duty cycle.	according to LED behavior

CAP1126

6.29 Linked LED Transition Control Register

TABLE 6-49: LINKED LED TRANSITION CONTROL REGISTER

ADDR	R/W	Register	B7	B6	B5	B4	B3	B2	B1	B0	Default
77h	R/W	Linked LED Transition Control	-	-	-	-	-	-	LED2_LTRAN	LED1_LTRAN	00h

The Linked LED Transition Control register controls the LED drive when the LED is linked to a capacitive touch sensor input. These controls work in conjunction with the INV_LINK_TRAN bit (see [Section 6.6.2, "Configuration 2 - 44h"](#)) to create smooth transitions from host control to linked LEDs.

Bit 1 - LED2_LTRAN - Determines the transition effect when LED2 is linked to CS2.

- '0' (default) - When the LED output control bit for LED2 is '1', and then LED2 is linked to CS2 and no touch is detected, the LED will change states.
- '1' - If the INV_LINK_TRAN bit is '1', when the LED output control bit for CS2 is '1', and then CS2 is linked to LED2 and no touch is detected, the LED will not change states. In addition, the LED state will change when the sensor pad is touched. If the INV_LINK_TRAN bit is '0', when the LED output control bit for CS2 is '1', and then CS2 is linked to LED2 and no touch is detected, the LED will not change states. However, the LED state will not change when the sensor pad is touched.

APPLICATION NOTE: If the LED behavior is not "Direct" and the INV_LINK_TRAN bit is '0', the LED will not perform as expected when the LED2_LTRAN bit is set to '1'. Therefore, if breathe and pulse behaviors are used, set the INV_LINK_TRAN bit to '1'.

Bit 0 - LED1_LTRAN - Determines the transition effect when LED1 is linked to CS1.

6.30 LED Mirror Control Register

TABLE 6-50: LED MIRROR CONTROL REGISTER

ADDR	R/W	Register	B7	B6	B5	B4	B3	B2	B1	B0	Default
79h	R/W	LED Mirror Control	-	-	-	-	-	-	LED2_MIR_EN	LED1_MIR_EN	00h

The LED Mirror Control Registers determine the meaning of duty cycle settings when polarity is non-inverted for each LED channel. When the polarity bit is set to '1' (non-inverted), to obtain correct steps for LED ramping, pulse, and breathe behaviors, the min and max duty cycles need to be relative to 100%, rather than the default, which is relative to 0%.

APPLICATION NOTE: The LED drive assumes that the LEDs are configured such that if the LED pin is driven to a logic '0', the LED will be on and the CAP1126 LED pin is sinking the LED current. When the polarity bit is set to '1', it is considered non-inverted. For systems using the opposite LED configuration, mirror controls would apply when the polarity bit is '0'.

These bits are changed automatically if the corresponding LED Polarity bit is changed (unless the BLK_POL_MIR bit is set - see [Section 6.6](#)).

Bit 1 - LED2_MIR_EN - Determines whether the duty cycle settings are "biased" relative to 0% or 100% duty cycle.

- '0' (default) - The duty cycle settings are determined relative to 0% and are determined directly with the settings.
- '1' - The duty cycle settings are determined relative to 100%.

Bit 0 - LED1_MIR_EN - Determines whether the duty cycle settings are "biased" relative to 0% or 100% duty cycle.

6.31 LED Behavior Register

TABLE 6-51: LED BEHAVIOR REGISTER

ADDR	R/W	Register	B7	B6	B5	B4	B3	B2	B1	B0	Default
81h	R/W	LED Behavior 1	-	-	-	-	LED2_CTL[1:0]		LED1_CTL[1:0]		00h

CAP1126

The LED Behavior register controls the operation of LEDs. Each LED pin is controlled by a 2-bit field and the behavior is determined by whether the LED is linked to a capacitive touch sensor input or not.

If the corresponding LED output is linked to a capacitive touch sensor input, the appropriate behavior will be enabled / disabled based on touches and releases.

If the LED output is not associated with a capacitive touch sensor input, the appropriate behavior will be enabled / disabled by the LED Output Control register. If the respective LEDx_DR bit is set to a logic '1', this will be associated as a "touch", and if the LEDx_DR bit is set to a logic '0', this will be associated as a "release".

[Table 6-52, "LEDx_CTL Bit Decode"](#) shows the behavior triggers. The defined behavior will activate when the Start Trigger is met and will stop when the Stop Trigger is met. Note the behavior of the Breathe Hold and Pulse Release option.

The LED Polarity Control register will determine the non actuated state of the LED outputs (see [Section 6.27, "LED Polarity Register"](#)).

APPLICATION NOTE: If an LED is not linked to a capacitive touch sensor input and is breathing (via the Breathe or Pulse behaviors), it must be unactuated and then re-actuated before changes to behavior are processed. For example, if the LED output is breathing and the Maximum duty cycle is changed, this change will not take effect until the LED output control register is set to '0' and then re-set to '1'.

APPLICATION NOTE: If an LED is not linked to the capacitive touch sensor input and configured to operate using Pulse 1 Behavior, then the circuitry will only be actuated when the corresponding output control bit is set. It will not check the bit condition until the Pulse 1 behavior is finished. The device will not remember if the bit was cleared and reset while it was actuated.

APPLICATION NOTE: If an LED is actuated and not linked and the desired LED behavior is changed, this new behavior will take effect immediately; however, the first instance of the changed behavior may act incorrectly (e.g. if changed from Direct to Pulse 1, the LED output may 'breathe' 4 times and then end at minimum duty cycle). LED Behaviors will operate normally once the LED has been un-actuated and then re-actuated.

APPLICATION NOTE: If an LED is actuated and it is switched from linked to a capacitive touch sensor input to unlinked (or vice versa), the LED will respond to the new command source immediately if the behavior was Direct or Breathe. For Pulse behaviors, it will complete the behavior already in progress. For example, if a linked LED was actuated by a touch and the control is changed so that it is unlinked, it will check the status of the corresponding LED Output Control bit. If that bit is '0', then the LED will behave as if a release was detected. Likewise, if an unlinked LED was actuated by the LED Output Control register and the control is changed so that it is linked and no touch is detected, then the LED will behave as if a release was detected.

Bits 3 - 2 - LED2_CTL[1:0] - Determines the behavior of LED2 as shown in [Table 6-52](#).

Bits 1 - 0 - LED1_CTL[1:0] - Determines the behavior of LED1 as shown in [Table 6-52](#).

TABLE 6-52: LEDX_CTL BIT DECODE

LEDx_CTL [1:0]		Operation	Description	Start TRigger	Stop Trigger
1	0				
0	0	Direct	The LED is driven to the programmed state (active or inactive). See Figure 6-7	Touch Detected or LED Output Control bit set	Release Detected or LED Output Control bit cleared
0	1	Pulse 1	The LED will “Pulse” a programmed number of times. During each “Pulse” the LED will breathe up to the maximum brightness and back down to the minimum brightness so that the total “Pulse” period matches the programmed value.	Touch or Release Detected or LED Output Control bit set or cleared (see Section 6.32)	n/a
1	0	Pulse 2	The LED will “Pulse” when the start trigger is detected. When the stop trigger is detected, it will “Pulse” a programmable number of times then return to its minimum brightness.	Touch Detected or LED Output Control bit set	Release Detected or LED Output Control bit cleared
1	1	Breathe	The LED will breathe. It will be driven with a duty cycle that ramps up from the programmed minimum duty cycle (default 0%) to the programmed maximum duty cycle duty cycle (default 100%) and then back down. Each ramp takes up 50% of the programmed period. The total period of each “breath” is determined by the LED Breathe Period controls - see Section 6.34 .	Touch Detected or LED Output Control bit set	Release Detected or LED Output Control bit cleared

APPLICATION NOTE: The PWM frequency is determined based on the selected LED behavior, the programmed breathe period, and the programmed min and max duty cycles. For the Direct behavior mode, the PWM frequency is calculated based on the programmed Rise and Fall times. If these are set at 0, then the maximum PWM frequency will be used based on the programmed duty cycle settings.

6.32 LED Pulse 1 Period Register

TABLE 6-53: LED PULSE 1 PERIOD REGISTER

ADDR	R/W	Register	B7	B6	B5	B4	B3	B2	B1	B0	Default
84h	R/W	LED Pulse 1 Period	ST_TRIG	P1_PER6	P1_PER5	P1_PER4	P1_PER3	P1_PER2	P1_PER1	P1_PER0	20h

The LED Pulse Period 1 register determines the overall period of a pulse operation as determined by the LED_CTL registers (see [Table 6-52](#) - setting 01b). The LSB represents 32ms so that a setting of 18h (24d) would represent a period of 768ms (24 x 32ms = 768ms). The total range is from 32ms to 4.064 seconds as shown in [Table 6-54](#) with the default being 1024ms.

APPLICATION NOTE: Due to constraints on the LED Drive PWM operation, any Breathe Period less than 160ms (05h) may not be achievable. The device will breathe at the minimum period possible as determined by the period and min / max duty cycle settings.

Bit 7 - ST_TRIG - Determines the start trigger for the LED Pulse behavior.

- ‘0’ (default) - The LED will Pulse when a touch is detected or the drive bit is set.
- ‘1’ - The LED will Pulse when a release is detected or the drive bit is cleared.

CAP1126

The Pulse 1 operation is shown in [Figure 6-1](#) when the LED output is configured for non-inverted polarity (LEDx_POL = 1) and in [Figure 6-2](#) for inverted polarity (LEDx_POL = 0).

FIGURE 6-1: Pulse 1 Behavior with Non-Inverted Polarity

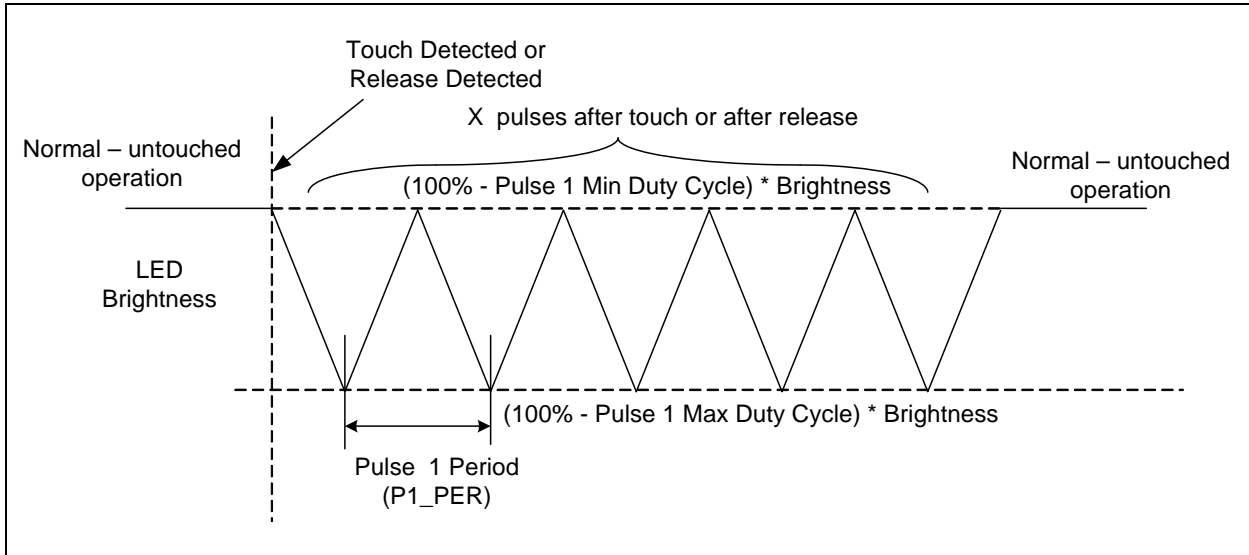

FIGURE 6-2: Pulse 1 Behavior with Inverted Polarity

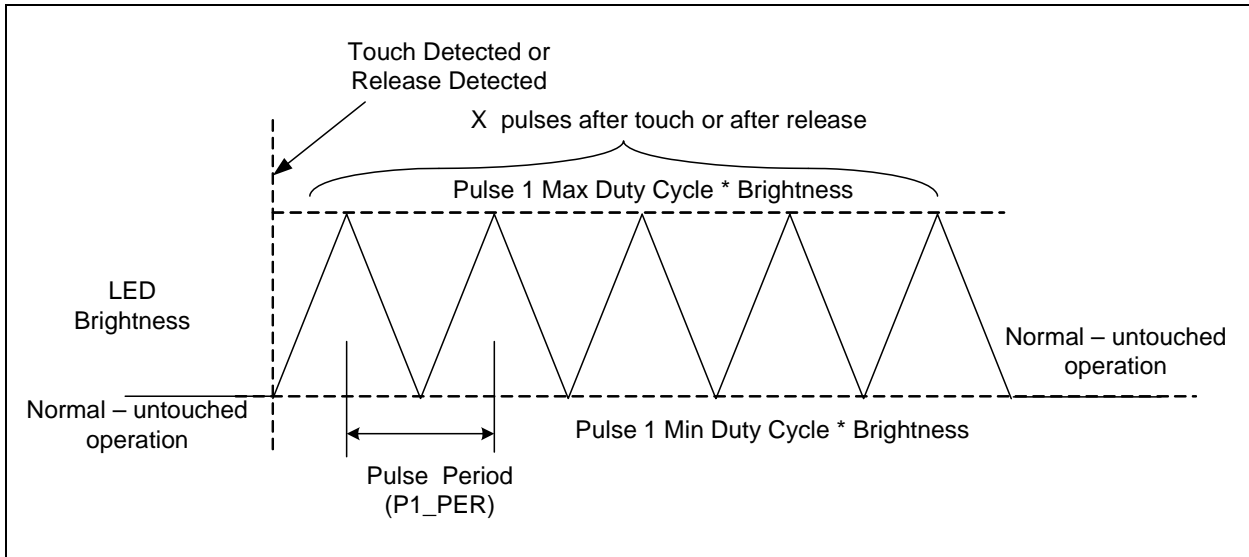

TABLE 6-54: LED PULSE / BREATHE PERIOD EXAMPLE

Setting (HEX)	Setting (Decimal)	Total Breathe / Pulse Period (MS)
00h	0	32
01h	1	32
02h	2	64
03h	3	96
...
7Dh	125	4000

CAP1126

TABLE 6-54: LED PULSE / BREATHE PERIOD EXAMPLE (CONTINUED)

Setting (HEX)	Setting (Decimal)	Total Breathe / Pulse Period (MS)
7Eh	126	4032
7Fh	127	4064

6.33 LED Pulse 2 Period Register

TABLE 6-55: LED PULSE 2 PERIOD REGISTER

ADDR	R/W	Register	B7	B6	B5	B4	B3	B2	B1	B0	Default
85h	R/W	LED Pulse 2 Period	-	P2_PER6	P2_PER5	P2_PER4	P2_PER3	P2_PER2	P2_PER1	P2_PER0	14h

The LED Pulse 2 Period register determines the overall period of a pulse operation as determined by the LED_CTL registers (see [Table 6-52](#) - setting 10b). The LSB represents 32ms so that a setting of 18h (24d) would represent a period of 768ms. The total range is from 32ms to 4.064 seconds (see [Table 6-54](#)) with a default of 640ms.

APPLICATION NOTE: Due to constraints on the LED Drive PWM operation, any Breathe Period less than 160ms (05h) may not be achievable. The device will breathe at the minimum period possible as determined by the period and min / max duty cycle settings.

The Pulse 2 Behavior is shown in [Figure 6-3](#) for non-inverted polarity (LEDx_POL = 1) and in [Figure 6-4](#) for inverted polarity (LEDx_POL = 0).

FIGURE 6-3: Pulse 2 Behavior with Non-Inverted Polarity

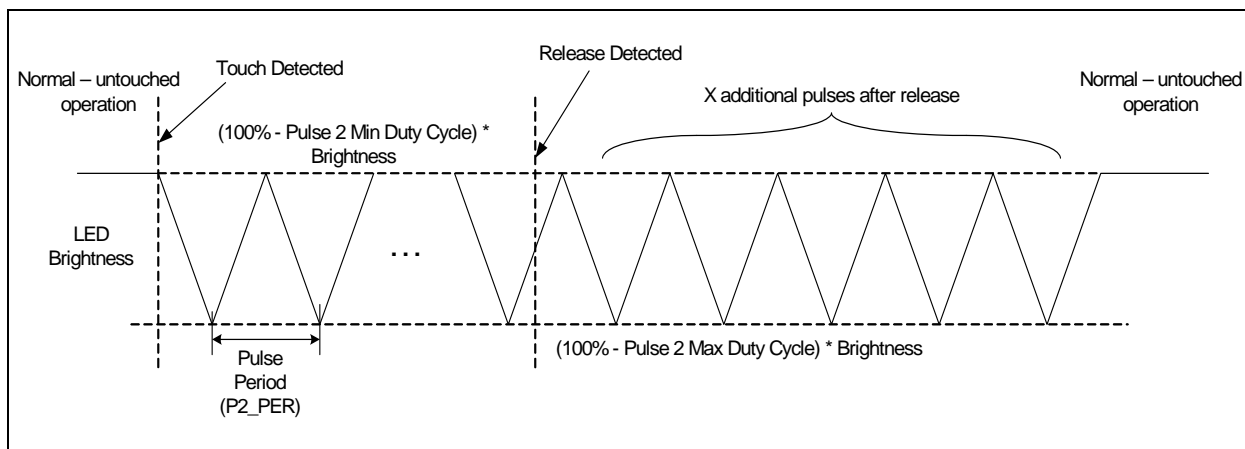
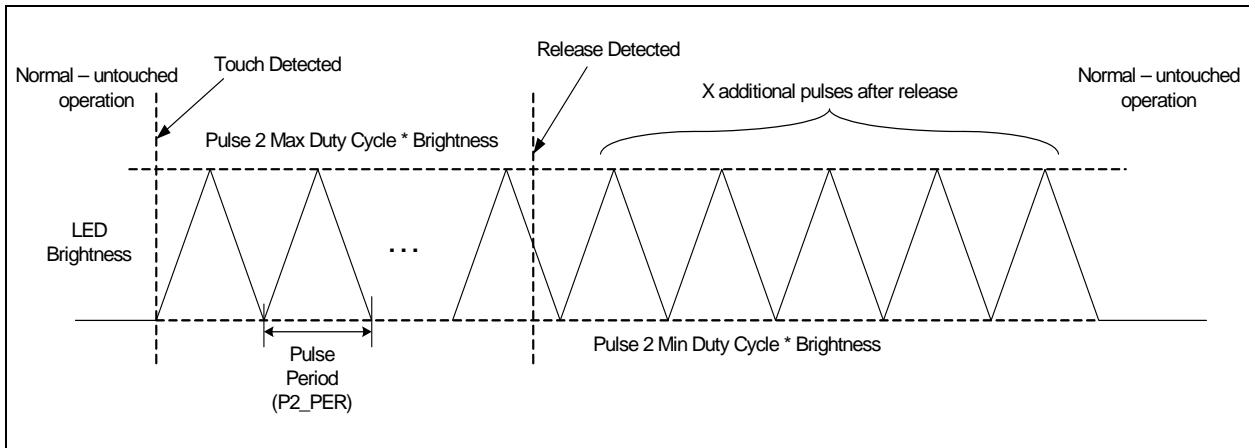

FIGURE 6-4: Pulse 2 Behavior with Inverted Polarity



6.34 LED Breathe Period Register

TABLE 6-56: LED BREATHE PERIOD REGISTER

ADDR	R/W	Register	B7	B6	B5	B4	B3	B2	B1	B0	Default
86h	R/W	LED Breathe Period	-	BR_PER6	BR_PER5	BR_PER4	BR_PER3	BR_PER2	BR_PER1	BR_PER0	5Dh

The LED Breathe Period register determines the overall period of a breathe operation as determined by the LED_CTL registers (see [Table 6-52](#) - setting 11b). The LSB represents 32ms so that a setting of 18h (24d) would represent a period of 768ms. The total range is from 32ms to 4.064 seconds (see [Table 6-54](#)) with a default of 2976ms.

APPLICATION NOTE: Due to constraints on the LED Drive PWM operation, any Breathe Period less than 160ms (05h) may not be achievable. The device will breathe at the minimum period possible as determined by the period and min / max duty cycle settings.

6.35 LED Configuration Register

TABLE 6-57: LED CONFIGURATION REGISTER

ADDR	R/W	Register	B7	B6	B5	B4	B3	B2	B1	B0	Default
88h	R/W	LED Config	-	RAMP_ALERT	PULSE2_CNT[2:0]			PULSE1_CNT[2:0]			04h

The LED Configuration register controls general LED behavior as well as the number of pulses that are sent for the PULSE LED output behavior.

Bit 6 - RAMP_ALERT - Determines whether the device will assert the ALERT# pin when LEDs actuated by the LED Output Control register bits have finished their respective behaviors. Interrupts will only be generated if the LED activity is generated by writing the LED Output Control registers. Any LED activity associated with touch detection will not cause an interrupt to be generated when the LED behavior has been finished.

- '0' (default) - The ALERT# pin will not be asserted when LEDs actuated by the LED Output Control register have finished their programmed behaviors.
- '1' - The ALERT# pin will be asserted whenever any LED that is actuated by the LED Output Control register has finished its programmed behavior.

Bits 5 - 3 - PULSE2_CNT[2:0] - Determines the number of pulses used for the Pulse 2 behavior as shown in [Table 6-58](#).

Bits 2 - 0 - PULSE1_CNT[2:0] - Determines the number of pulses used for the Pulse 1 behavior as shown in [Table 6-58](#).

CAP1126

TABLE 6-58: PULSEX_CNT DECODE

PULSEX_CNT[2:0]			Number of Breaths
2	1	0	
0	0	0	1 (default - Pulse 2)
0	0	1	2
0	1	0	3
0	1	1	4
1	0	0	5 (default - Pulse 1)
1	0	1	6
1	1	0	7
1	1	1	8

6.36 LED Duty Cycle Registers

TABLE 6-59: LED DUTY CYCLE REGISTERS

ADDR	R/W	Register	B7	B6	B5	B4	B3	B2	B1	B0	Default
90h	R/W	LED Pulse 1 Duty Cycle	P1_MAX_DUTY[3:0]				P1_MIN_DUTY[3:0]				F0h
91h	R/W	LED Pulse 2 Duty Cycle	P2_MAX_DUTY[3:0]				P2_MIN_DUTY[3:0]				F0h
92h	R/W	LED Breathe Duty Cycle	BR_MAX_DUTY[3:0]				BR_MIN_DUTY[3:0]				F0h
93h	R/W	Direct Duty Cycle	DR_MAX_DUTY[3:0]				DR_MIN_DUTY[3:0]				F0h

The LED Duty Cycle registers determine the minimum and maximum duty cycle settings used for the LED for each LED behavior. These settings affect the brightness of the LED when it is fully off and fully on.

The LED driver duty cycle will ramp up from the minimum duty cycle to the maximum duty cycle and back down again.

APPLICATION NOTE: When operating in Direct behavior mode, changes to the Duty Cycle settings will be applied immediately. When operating in Breathe, Pulse 1, or Pulse 2 modes, the LED must be unactuated and then re-actuated before changes to behavior are processed.

Bits 7 - 4 - X_MAX_DUTY[3:0] - Determines the maximum PWM duty cycle for the LED drivers as shown in [Table 6-60](#).

Bits 3 - 0 - X_MIN_DUTY[3:0] - Determines the minimum PWM duty cycle for the LED drivers as shown in [Table 6-60](#).

TABLE 6-60: LED DUTY CYCLE DECODE

x_MAX/MIN_Duty [3:0]				Maximum Duty Cycle	Minimum Duty Cycle
3	2	1	0		
0	0	0	0	7%	0%
0	0	0	1	9%	7%
0	0	1	0	11%	9%
0	0	1	1	14%	11%
0	1	0	0	17%	14%
0	1	0	1	20%	17%
0	1	1	0	23%	20%
0	1	1	1	26%	23%
1	0	0	0	30%	26%
1	0	0	1	35%	30%
1	0	1	0	40%	35%

CAP1126

TABLE 6-60: LED DUTY CYCLE DECODE (CONTINUED)

x_MAX/MIN_Duty [3:0]				Maximum Duty Cycle	Minimum Duty Cycle
3	2	1	0		
1	0	1	1	46%	40%
1	1	0	0	53%	46%
1	1	0	1	63%	53%
1	1	1	0	77%	63%
1	1	1	1	100%	77%

6.37 LED Direct Ramp Rates Register

TABLE 6-61: LED DIRECT RAMP RATES REGISTER

ADDR	R/W	Register	B7	B6	B5	B4	B3	B2	B1	B0	Default
94h	R/W	LED Direct Ramp Rates	-	-	RISE_RATE[2:0]			FALL_RATE[2:0]			00h

The LED Direct Ramp Rates register control the rising and falling edge time of an LED that is configured to operate in Direct behavior mode. The rising edge time corresponds to the amount of time the LED takes to transition from its minimum duty cycle to its maximum duty cycle. Conversely, the falling edge time corresponds to the amount of time that the LED takes to transition from its maximum duty cycle to its minimum duty cycle.

Bits 5 - 3 - RISE_RATE[2:0] - Determines the rising edge time of an LED when it transitions from its minimum drive state to its maximum drive state as shown in [Table 6-62](#).

Bits 2 - 0 - FALL_RATE[2:0] - Determines the falling edge time of an LED when it transitions from its maximum drive state to its minimum drive state as shown in [Table 6-62](#).

TABLE 6-62: RISE / FALL RATE DECODE

RISE_RATE/ FALL_RATE/ Bit Decode			Rise / Fall Time (T _{RISE} / T _{FALL})
2	1	0	
0	0	0	0
0	0	1	250ms
0	1	0	500ms
0	1	1	750ms
1	0	0	1s
1	0	1	1.25s
1	1	0	1.5s
1	1	1	2s

6.38 LED Off Delay Register

TABLE 6-63: LED OFF DELAY REGISTER

ADDR	R/W	Register	B7	B6	B5	B4	B3	B2	B1	B0	Default
95h	R/W	LED Off Delay Register	-	BR_OFF_DLY[2:0]			DIR_OFF_DLY[3:0]			00h	

The LED Off Delay register determines the amount of time that an LED remains at its maximum duty cycle (or minimum as determined by the polarity controls) before it starts to ramp down. If the LED is operating in Breathe mode, this delay is applied at the top of each “breath”. If the LED is operating in the Direct mode, this delay is applied when the LED is unactuated.

CAP1126

Bits 6 - 4 - BR_OFF_DLY[2:0] - Determines the Breathe behavior mode off delay, which is the amount of time an LED in Breathe behavior mode remains inactive after it finishes a breathe pulse (ramp on and ramp off), as shown in [Figure 6-5](#) (non-inverted polarity LEDx_POL = 1) and [Figure 6-6](#) (inverted polarity LEDx_POL = 0). Available settings are shown in [Table 6-64](#).

FIGURE 6-5: Breathe Behavior with Non-Inverted Polarity

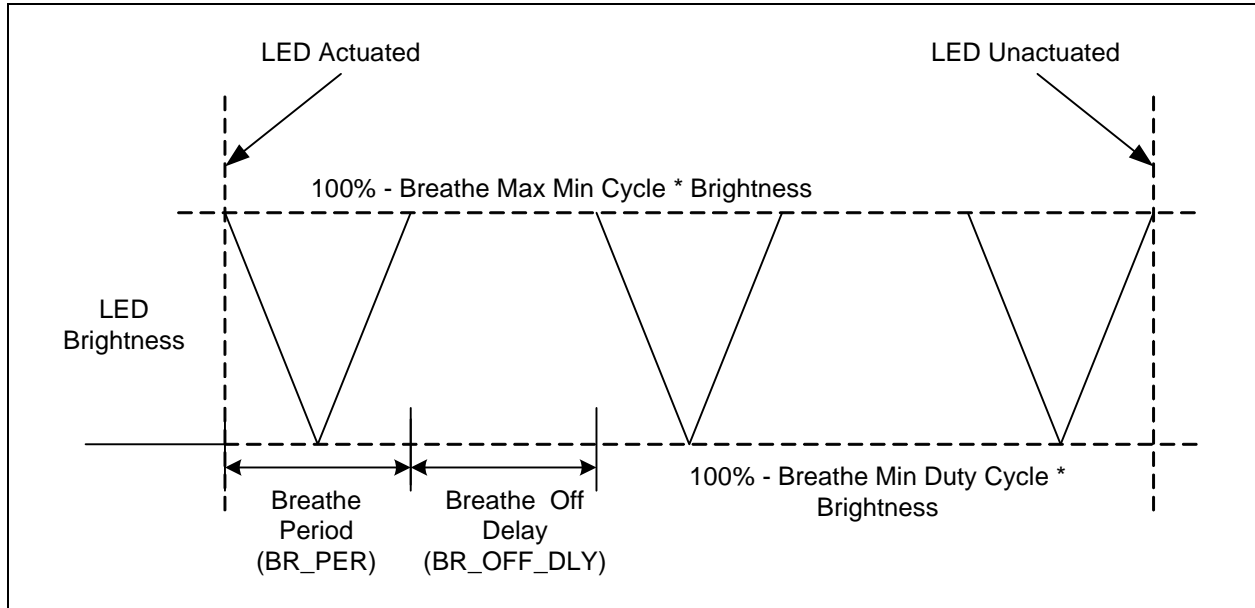

FIGURE 6-6: Breathe Behavior with Inverted Polarity

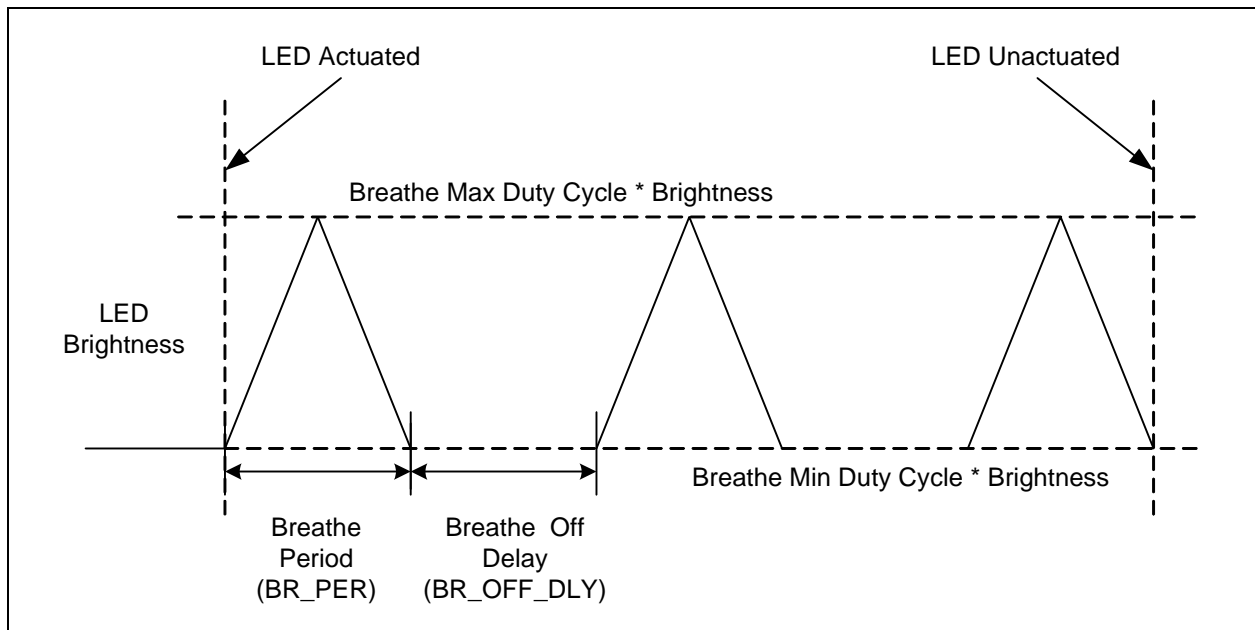

TABLE 6-64: BREATHE OFF DELAY SETTINGS

BR_OFF_DLY [2:0]			OFF Delay
2	1	0	
0	0	0	0 (default)
0	0	1	0.25s
0	1	0	0.5s
0	1	1	0.75s
1	0	0	1.0s
1	0	1	1.25s
1	1	0	1.5s
1	1	1	2.0s

Bits 3 - 0 - DIR_OFF_DLY[3:0] - Determines the turn-off delay, as shown in Table 6-65, for all LEDs that are configured to operate in Direct behavior mode.

The Direct behavior operation is determined by the combination of programmed Rise Time, Fall Time, Min and Max Duty cycles, Off Delay, and polarity. Figure 6-7 shows the behavior for non-inverted polarity (LEDx_POL = 1) while Figure 6-8 shows the behavior for inverted polarity (LEDx_POL = 0).

FIGURE 6-7: Direct Behavior for Non-Inverted Polarity

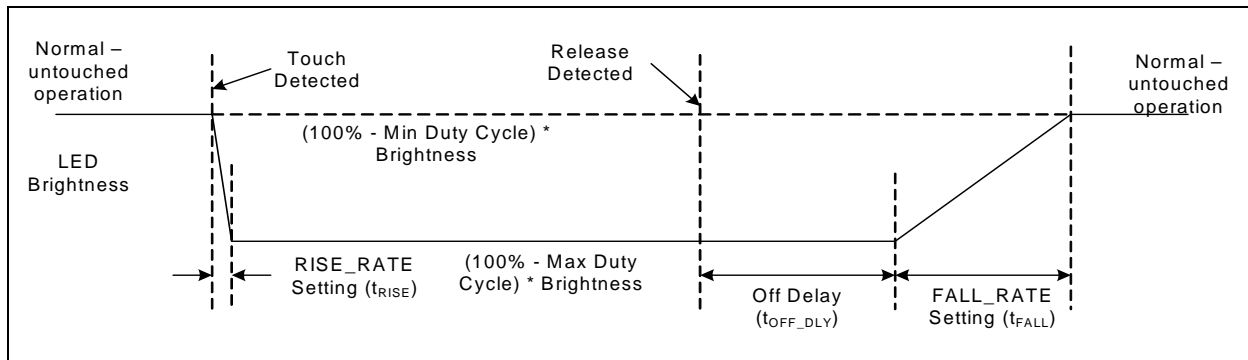
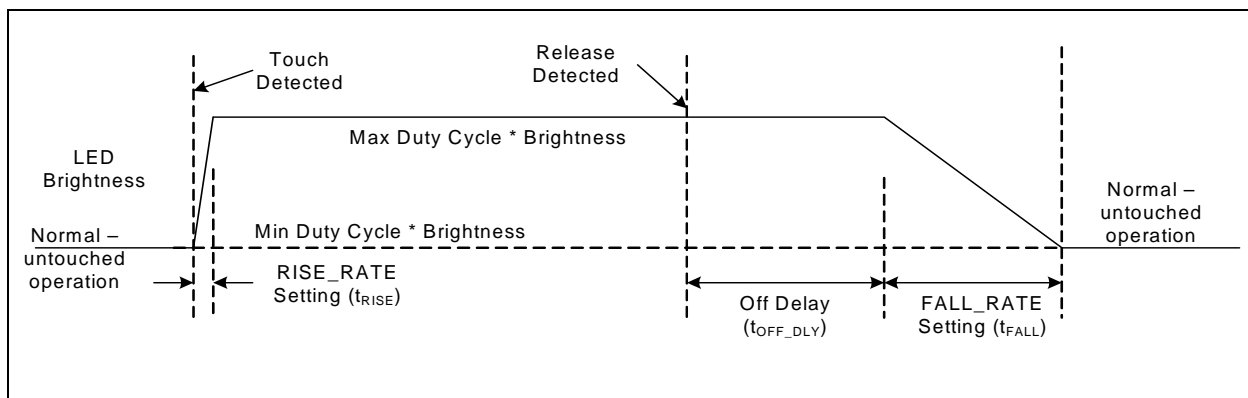

FIGURE 6-8: Direct Behavior for Inverted Polarity



CAP1126

TABLE 6-65: OFF DELAY DECODE

OFF Delay[3:0] Bit Decode				OFF Delay (t_{OFF_DLY})
3	2	1	0	
0	0	0	0	0
0	0	0	1	250ms
0	0	1	0	500ms
0	0	1	1	750ms
0	1	0	0	1s
0	1	0	1	1.25s
0	1	1	0	1.5s
0	1	1	1	2s
1	0	0	0	2.5s
1	0	0	1	3.0s
1	0	1	0	3.5s
1	0	1	1	4.0s
1	1	0	0	4.5s
All others				5.0s

6.39 Sensor Input Calibration Registers

TABLE 6-66: SENSOR INPUT CALIBRATION REGISTERS

ADDR	Register	R/W	B7	B6	B5	B4	B3	B2	B1	B0	Default
B1h	Sensor Input 1 Calibration	R	CAL1_9	CAL1_8	CAL1_7	CAL1_6	CAL1_5	CAL1_4	CAL1_3	CAL1_2	00h
B2h	Sensor Input 2 Calibration	R	CAL2_9	CAL2_8	CAL2_7	CAL2_6	CAL2_5	CAL2_4	CAL2_3	CAL2_2	00h
B3h	Sensor Input 3 Calibration	R	CAL3_9	CAL3_8	CAL3_7	CAL3_6	CAL3_5	CAL3_4	CAL3_3	CAL3_2	00h
B4h	Sensor Input 4 Calibration	R	CAL4_9	CAL4_8	CAL4_7	CAL4_6	CAL4_5	CAL4_4	CAL4_3	CAL4_2	00h
B5h	Sensor Input 5 Calibration	R	CAL5_9	CAL5_8	CAL5_7	CAL5_6	CAL5_5	CAL5_4	CAL5_3	CAL5_2	00h
B6h	Sensor Input 6 Calibration	R	CAL6_9	CAL6_8	CAL6_7	CAL6_6	CAL6_5	CAL6_4	CAL6_3	CAL6_2	00h
B9h	Sensor Input Calibration LSB 1	R	CAL4_1	CAL4_0	CAL3_1	CAL3_0	CAL2_1	CAL2_0	CAL1_1	CAL1_0	00h
BAh	Sensor Input Calibration LSB 2	R	-	-	-	-	CAL6_1	CAL6_0	CAL5_1	CAL5_0	00h

The Sensor Input Calibration registers hold the 10-bit value that represents the last calibration value.

6.40 Product ID Register

TABLE 6-67: PRODUCT ID REGISTER

ADDR	R/W	Register	B7	B6	B5	B4	B3	B2	B1	B0	Default
FDh	R	Product ID	0	1	0	1	0	0	1	1	53h

The Product ID register stores a unique 8-bit value that identifies the device.

6.41 Manufacturer ID Register

TABLE 6-68: VENDOR ID REGISTER

ADDR	R/W	Register	B7	B6	B5	B4	B3	B2	B1	B0	Default
FEh	R	Manufacturer ID	0	1	0	1	1	1	0	1	5Dh

The Vendor ID register stores an 8-bit value that represents Microchip.

6.42 Revision Register

TABLE 6-69: REVISION REGISTER

ADDR	R/W	Register	B7	B6	B5	B4	B3	B2	B1	B0	Default
FFh	R	Revision	1	0	0	0	0	0	1	1	83h

The Revision register stores an 8-bit value that represents the part revision.

CAP1126

7.0 PACKAGE INFORMATION

Note: For the most current package drawings, see the Microchip Packaging Specification at: <http://www.microchip.com/packaging>.

7.1 CAP1126 Package Drawings

FIGURE 7-1: 16-Pin QFN 4mm x 4mm Package Drawing

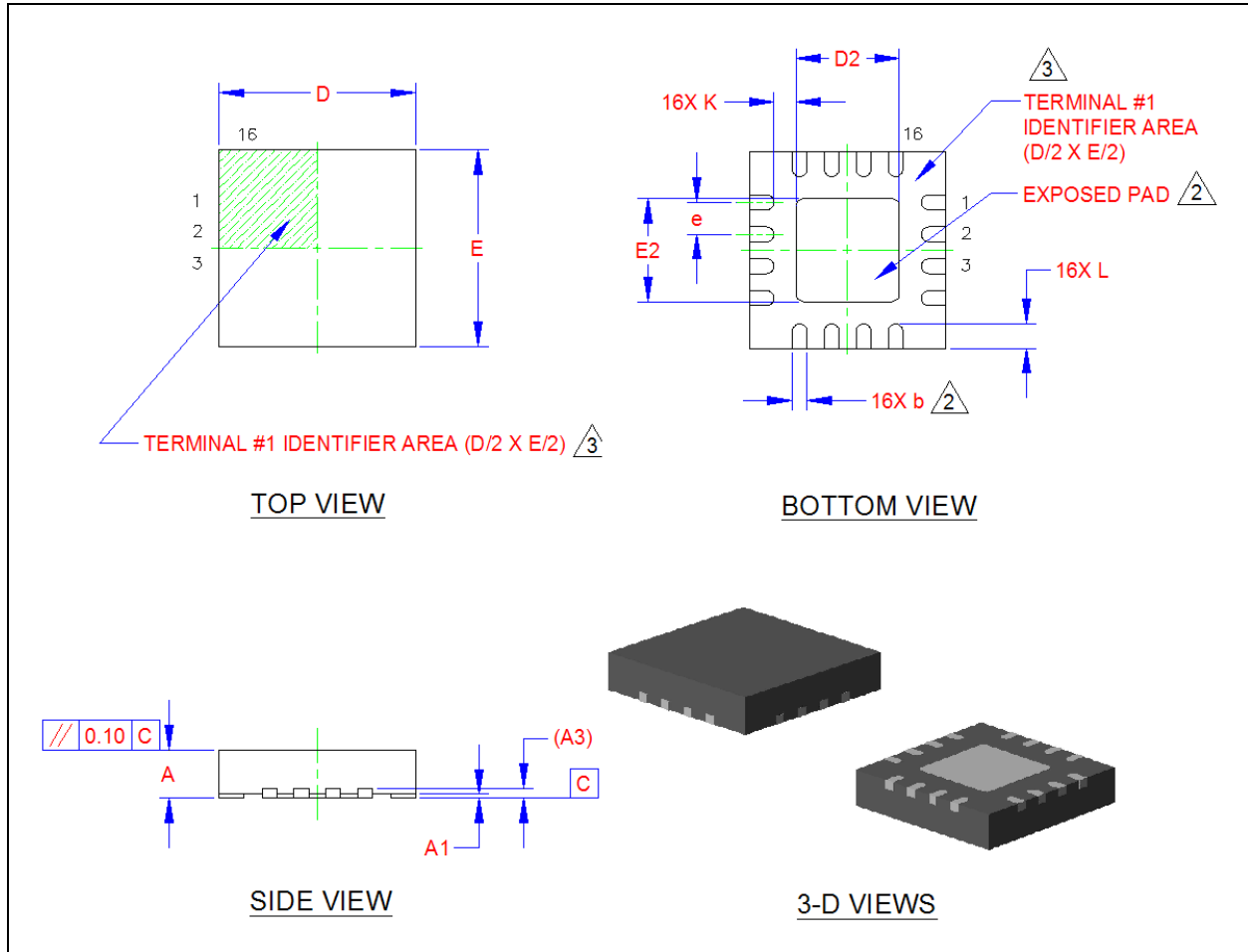

FIGURE 7-2: 16-Pin QFN 4mm x 4mm Package Dimensions

COMMON DIMENSIONS					
SYMBOL	MIN	NOM	MAX	NOTE	REMARK
A	0.80	0.85	0.90	-	OVERALL PACKAGE HEIGHT
A1	0	0.02	0.05	-	STANDOFF
A3	0.20 REF			-	LEAD-FRAME THICKNESS
D/E	3.90	4.00	4.10	-	X/Y BODY SIZE
D2/E2	2.00	2.10	2.20	2	X/Y EXPOSED PAD SIZE
L	0.45	0.50	0.55	-	TERMINAL LENGTH
b	0.25	0.30	0.35	2	TERMINAL WIDTH
K	0.20	-	-	-	TERMINAL TO PAD DISTANCE
e	0.65 BSC			-	TERMINAL PITCH

NOTES:

1. ALL DIMENSIONS ARE IN MILLIMETERS.
2. POSITION TOLERANCE OF EACH TERMINAL AND EXPOSED PAD IS $\pm 0.05\text{mm}$ AT MAXIMUM MATERIAL CONDITION. DIMENSIONS "b" APPLIES TO PLATED TERMINALS AND IT IS MEASURED BETWEEN 0.15 AND 0.30 mm FROM THE TERMINAL TIP.
3. DETAILS OF TERMINAL #1 IDENTIFIER ARE OPTIONAL BUT MUST BE LOCATED WITHIN THE AREA INDICATED.

FIGURE 7-3: 16-Pin QFN 4mm x 4mm PCB Footprint

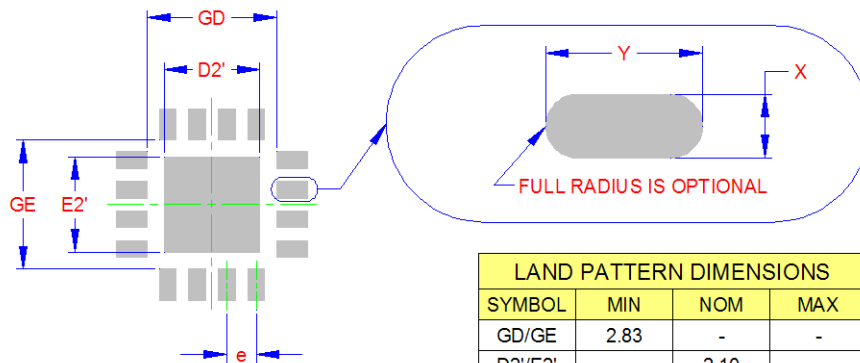

THE USER MAY MODIFY THE PCB LAND PATTERN DIMENSIONS BASED ON THEIR EXPERIENCE AND/OR PROCESS CAPABILITY

LAND PATTERN DIMENSIONS			
SYMBOL	MIN	NOM	MAX
GD/GE	2.83	-	-
D2'/E2'	-	2.10	-
X	-	-	0.37
Y	-	-	0.69
e	0.65		

CAP1126

7.2 Package Marking

FIGURE 7-4: CAP1126 Package Markings

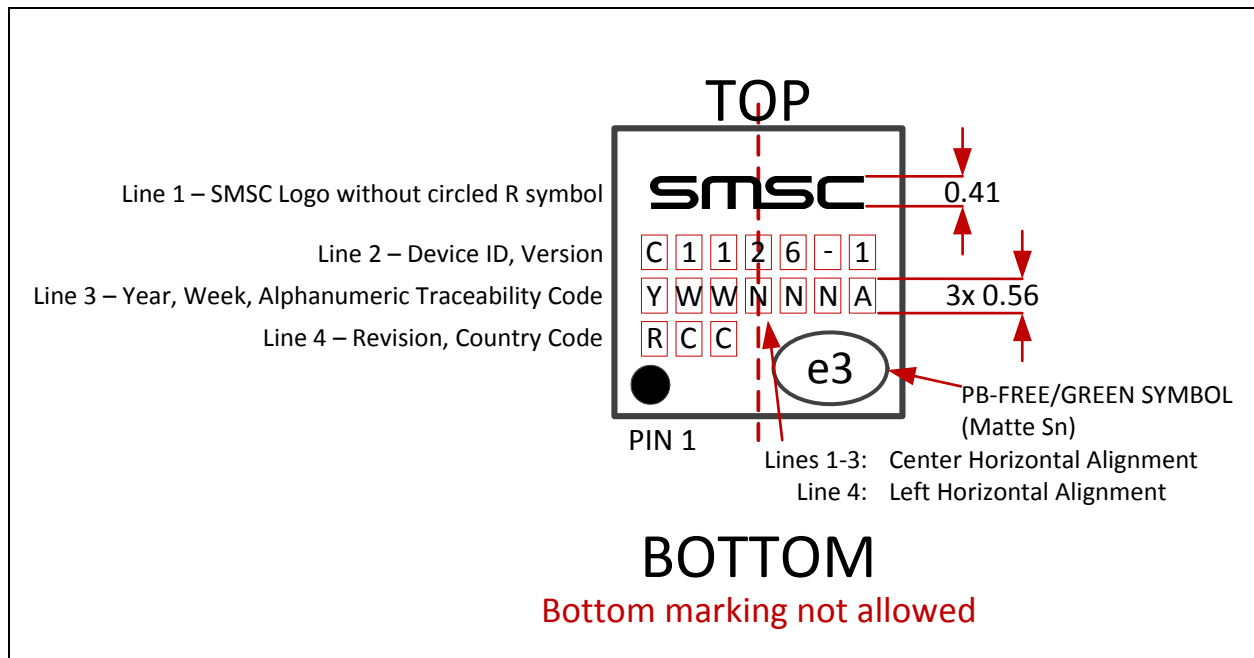

CAP1126

APPENDIX A: DEVICE DELTA

A.1 Delta from CAP1026 to CAP1126

1. Updated circuitry to improve power supply rejection.
2. Updated LED driver duty cycle decode values to have more distribution at lower values - closer to a logarithmic curve. See [Table 6-60, "LED Duty Cycle Decode"](#).
3. Updated bug that breathe periods were not correct above 2.6s. This includes rise / fall time decodes above 1.5s.
4. Added filtering on RESET pin to prevent errant resets.
5. Updated controls so that the RESET pin assertion places the device into the lowest power state available and causes an interrupt when released. See [Section 5.2, "RESET Pin"](#).
6. Added 1 bit to the LED Off Delay register (see [Section 6.38, "LED Off Delay Register"](#)) to extend times from 2s to 5s in 0.5s intervals.
7. Breathe behavior modified. A breathe off delay control was added to the LED Off Delay Register (see [Section 6.38, "LED Off Delay Register"](#)) so the LEDs can be configured to remain inactive between breathes.
8. Added controls for the LED transition effects when linking LEDs to capacitive sensor inputs. See [Section 6.29, "Linked LED Transition Control Register"](#).
9. Added controls to "mirror" the LED duty cycle outputs so that when polarity changes, the LED brightness levels look right. These bits are automatically set when polarity is set. Added control to break this auto-set behavior. See [Section 6.30, "LED Mirror Control Register"](#).
10. Added Multiple Touch Pattern detection circuitry. See [Section 6.15, "Multiple Touch Pattern Configuration Register"](#).
11. Added General Status register to flag Multiple touches, Multiple Touch Pattern issues and general touch detections. See [Section 6.2, "Status Registers"](#).
12. Added bits 6 and 5 to the Recalibration Configuration register (2Fh - see [Section 6.17, "Recalibration Configuration Register"](#)). These bits control whether the accumulation of intermediate data and the consecutive negative delta counts counter are cleared when the noise status bit is set.
13. Added Configuration 2 register for LED linking controls, noise detection controls, and control to interrupt on press but not on release. Added control to change alert pin polarity. See [Section 6.6, "Configuration Registers"](#).
14. Updated Deep Sleep behavior so that device does not clear DSLEEP bit on received communications but will wake to communicate.
15. Changed PWM frequency for LED drivers. The PWM frequency was derived from the programmed breathe period and duty cycle settings and it ranged from ~4Hz to ~8000 Hz. The PWM frequency has been updated to be a fixed value of ~2000Hz.
16. Register delta:

Table A.1 Register Delta From CAP1026 to CAP1126

Address	Register Delta	Delta	Default
00h Page 31	Changed - Main Status / Control	added bits 7-6 to control gain	00h
02h Page 32	New - General Status	new register to store MTP, MULT, LED, RESET, and general TOUCH bits	00h
44h Page 35	New - Configuration 2	new register to control alert polarity, LED touch linking behavior, LED output behavior, and noise detection, and interrupt on release	40h
24h Page 38	Changed - Averaging Control	updated register bits - moved SAMP_AVG[2:0] bits and added SAMP_TIME bit 1. Default changed	39h
2Bh Page 41	New - Multiple Touch Pattern Configuration	new register for Multiple Touch Pattern configuration - enable and threshold settings	80h

CAP1126

Table A.1 Register Delta From CAP1026 to CAP1126 (continued)

Address	Register Delta	Delta	Default
2Dh Page 42	New - Multiple Touch Pattern Register	new register for Multiple Touch Pattern detection circuitry - pattern or number of sensor inputs	3Fh
2Fh Page 43	Changed - Recalibration Configuration	updated register - updated CAL_CFG bit decode to add a 128 averages setting and removed highest time setting. Default changed. Added bit 6 NO_CLR_INTD and bit 5 NO_CLR_NEG.	8Ah
38h Page 44	Changed - Sensor Input Noise Threshold	updated register bits - removed bits 7 - 3 and consolidated all controls into bits 1 - 0. These bits will set the noise threshold for all channels. Default changed	01h
39h	Removed - Noise Threshold Register 2	removed register	n/a
41h Page 45	Changed - Standby Configuration	updated register bits - moved STBY_AVG[2:0] bits and added STBY_TIME bit 1. Default changed	39h
77h Page 51	New - Linked LED Transition Control	new register to control transition effect when LED linked to sensor inputs	00h
79h Page 51	New - LED Mirror Control	new register to control LED output mirroring for brightness control when polarity changed	00h
90h Page 57	Changed - LED Pulse 1 Duty Cycle	changed bit decode to be more logarithmic	F0h
91h Page 57	Changed - LED Pulse 2 Duty Cycle	changed bit decode to be more logarithmic	F0h
92h Page 57	Changed - LED Breathe Duty Cycle	changed bit decode to be more logarithmic	F0h
93h Page 57	Changed - LED Direct Duty Cycle	changed bit decode to be more logarithmic	F0h
95h	Added controls - LED Off Delay	Added bits 6-4 BR_OFF_DLY[2:0] Added bit 3 DIR_OFF_DLY[3]	00h
FDh Page 62	Changed - Product ID	Changed bit decode for CAP1126	53h

APPENDIX B: DATA SHEET REVISION HISTORY

Revision	Section/Figure/Entry	Correction
DS00001623B (02-09-15)	Features, Table 2-1 , Table 2-2 , "Pin Types", Section 5.0 , "General Description"	References to BC-Link Interface, BC_DATA, BC_CLK, BC-IRQ#, BC-Link bus have been removed
	Application Note under Table 2-6	[BC-Link] hidden in data sheet
	Table 3-2 , "Electrical Specifications"	BC-Link Timing Section hidden in data sheet
	Table 4-1	Protocol Used for 68K Pull Down Resistor changed from "BC-Link Communications" to "Reserved"
	Section 4.2.2 , "SMBus Address and RD / WR Bit"	Replaced "client address" with "slave address" in this section.
	Section 4.2.4 , SMBus ACK and NACK Bits, Section 4.2.5 , SMBus Stop Bit, Section 4.2.7 , SMBus and I2C Compatibility	Replaced "client" with "slave" in these sections.
	Table 4-4 , "Read Byte Protocol"	Heading changed from "Client Address" to "Slave Address"
	Table 6-1	Register Name for Register Address 77h changed from "LED Linked Transition Control" to "Linked LED Transition Control"
	Section 6.30	changed CS2 to LED2
	Section 7.7 Package Marking	Updated package drawing
	Appendix A : Device Delta	changed 2Dh to 2Fh in item #12
	Product Identification System	Removed BC-Link references
REV A	REV A replaces previous SMSC version Rev. 1.32 (01-05-12)	
Rev. 1.32 (01-05-12)	Table 3-2 , "Electrical Specifications"	Added conditions for $t_{HD:DAT}$
	Section 4.2.7 , "SMBus and I2C Compatibility"	Renamed from "SMBus and I2C Compliance." First paragraph, added last sentence: "For information on using the CAP1188 in an I ² C system, refer to SMSC AN 14.0 SMSC Dedicated Slave Devices in I ² C Systems." Added: CAP1188 supports I ² C fast mode at 400kHz. This covers the SMBus max time of 100kHz.
	Section 6.4 , "Sensor Input Delta Count Registers"	Changed negative value cap from FFh to 80h.
Rev. 1.31 (08-18-11)	Section 4.3.3 , "SMBus Send Byte"	Added an application note: The Send Byte protocol is not functional in Deep Sleep (i.e., DSLEEP bit is set).
	Section 4.3.4 , "SMBus Receive Byte"	Added an application note: The Receive Byte protocol is not functional in Deep Sleep (i.e., DSLEEP bit is set).
Rev. 1.3 (05-18-11)	Section 6.42 , "Revision Register"	Updated revision ID from 82h to 83h.
Rev. 1.2 (02-10-11)	Section A.8 , "Delta from Rev B (Mask B0) to Rev C (Mask B1)"	Added.
	Cover	Corrected block diagram. ALERT#/BC_IRQ# is an output, not an input.

CAP1126

Revision	Section/Figure/Entry	Correction
	Table 2-1, "Pin Description for CAP1126"	Changed value in "Unused Connection" column for the ADDR_COMM pin from "Connect to Ground" to "n/a".
	Table 3-2, "Electrical Specifications"	PSR improvements made in functional revision B. Changed PSR spec from ± 100 typ and ± 200 max counts / V to ± 3 and ± 10 counts / V. Conditions updated.
	Section 5.5.2, "Recalibrating Sensor Inputs"	Added more detail with subheadings for each type of recalibration.
	Section 6.6, "Configuration Registers"	Added bit 5 BLK_PWR_CTRL to the Configuration 2 Register 44h. The TIMEOUT bit is set to '1' by default for functional revision B and is set to '0' by default for functional revision C.
	Section 6.42, "Revision Register"	Updated revision ID in register FFh from 81h to 82h.
Rev. 1.1 (11-17-10)	Document	Updated for functional revision B. See Section A.7, "Delta from Rev A (Mask A0) to Rev B (Mask B0)".
	Cover	Added to General Description: "includes circuitry and support for enhanced sensor proximity detection." Added the following Features: Calibrates for Parasitic Capacitance Analog Filtering for System Noise Sources Press and Hold feature for Volume-like Applications
	Table 3-2, "Electrical Specifications"	Conditions for Power Supply Rejection modified adding the following: Sampling time = 2.56ms Averaging = 1 Negative Delta Counts = Disabled All other parameters default
	Section 6.11, "Calibration Activate Register"	Updated register description to indicate which re-calibration routine is used.
	Section 6.14, "Multiple Touch Configuration Register"	Updated register description to indicate what will happen.
	Table 6-34, "CSx_BN_TH Bit Decode"	Table heading changed from "Threshold Divide Setting" to "Percent Threshold Setting".
Rev. 1.0 (06-14-10)	Initial release	

THE MICROCHIP WEB SITE

Microchip provides online support via our WWW site at www.microchip.com. This web site is used as a means to make files and information easily available to customers. Accessible by using your favorite Internet browser, the web site contains the following information:

- **Product Support** – Data sheets and errata, application notes and sample programs, design resources, user's guides and hardware support documents, latest software releases and archived software
- **General Technical Support** – Frequently Asked Questions (FAQ), technical support requests, online discussion groups, Microchip consultant program member listing
- **Business of Microchip** – Product selector and ordering guides, latest Microchip press releases, listing of seminars and events, listings of Microchip sales offices, distributors and factory representatives

CUSTOMER CHANGE NOTIFICATION SERVICE

Microchip's customer notification service helps keep customers current on Microchip products. Subscribers will receive e-mail notification whenever there are changes, updates, revisions or errata related to a specified product family or development tool of interest.

To register, access the Microchip web site at www.microchip.com. Under "Support", click on "Customer Change Notification" and follow the registration instructions.

CUSTOMER SUPPORT

Users of Microchip products can receive assistance through several channels:

- Distributor or Representative
- Local Sales Office
- Field Application Engineer (FAE)
- Technical Support

Customers should contact their distributor, representative or field application engineer (FAE) for support. Local sales offices are also available to help customers. A listing of sales offices and locations is included in the back of this document.

Technical support is available through the web site at: <http://www.microchip.com/support>

CAP1126

PRODUCT IDENTIFICATION SYSTEM

To order or obtain information, e.g., on pricing or delivery, refer to the factory or the listed sales office.

PART NO. [X] - 1 - XXX - [X]⁽¹⁾
Device Temperature Range Package Tape and Reel Option

Device:	CAP1126
Temperature Range:	Blank = 0°C to +85°C (Extended Commercial)
Package:	AP = QFN
Tape and Reel Option:	TR = Tape and Reel ⁽¹⁾

Example:

CAP1126-1-AP-TR 16-pin QFN 4mm x 4mm (RoHS compliant) Six capacitive touch sensor inputs, Two LED drivers, Dedicated Wake, Reset, SMBus / BC-Link / SPI interfaces Reel size is 4,000 pieces

Note 1: Tape and Reel identifier only appears in the catalog part number description. This identifier is used for ordering purposes and is not printed on the device package. Check with your Microchip Sales Office for package availability with the Tape and Reel option.

Note the following details of the code protection feature on Microchip devices:

- Microchip products meet the specification contained in their particular Microchip Data Sheet.
- Microchip believes that its family of products is one of the most secure families of its kind on the market today, when used in the intended manner and under normal conditions.
- There are dishonest and possibly illegal methods used to breach the code protection feature. All of these methods, to our knowledge, require using the Microchip products in a manner outside the operating specifications contained in Microchip's Data Sheets. Most likely, the person doing so is engaged in theft of intellectual property.
- Microchip is willing to work with the customer who is concerned about the integrity of their code.
- Neither Microchip nor any other semiconductor manufacturer can guarantee the security of their code. Code protection does not mean that we are guaranteeing the product as “unbreakable.”

Code protection is constantly evolving. We at Microchip are committed to continuously improving the code protection features of our products. Attempts to break Microchip's code protection feature may be a violation of the Digital Millennium Copyright Act. If such acts allow unauthorized access to your software or other copyrighted work, you may have a right to sue for relief under that Act.

Information contained in this publication regarding device applications and the like is provided only for your convenience and may be superseded by updates. It is your responsibility to ensure that your application meets with your specifications. MICROCHIP MAKES NO REPRESENTATIONS OR WARRANTIES OF ANY KIND WHETHER EXPRESS OR IMPLIED, WRITTEN OR ORAL, STATUTORY OR OTHERWISE, RELATED TO THE INFORMATION, INCLUDING BUT NOT LIMITED TO ITS CONDITION, QUALITY, PERFORMANCE, MERCHANTABILITY OR FITNESS FOR PURPOSE. Microchip disclaims all liability arising from this information and its use. Use of Microchip devices in life support and/or safety applications is entirely at the buyer's risk, and the buyer agrees to defend, indemnify and hold harmless Microchip from any and all damages, claims, suits, or expenses resulting from such use. No licenses are conveyed, implicitly or otherwise, under any Microchip intellectual property rights.

Trademarks

The Microchip name and logo, the Microchip logo, dsPIC, FlashFlex, flexPWR, JukeBlox, KEELOQ, KEELOQ logo, Kleer, LANCheck, MediaLB, MOST, MOST logo, MPLAB, OptoLyzer, PIC, PICSTART, PIC³² logo, RightTouch, SpyNIC, SST, SST Logo, SuperFlash and UNI/O are registered trademarks of Microchip Technology Incorporated in the U.S.A. and other countries.

The Embedded Control Solutions Company and mTouch are registered trademarks of Microchip Technology Incorporated in the U.S.A.

Analog-for-the-Digital Age, BodyCom, chipKIT, chipKIT logo, CodeGuard, dsPICDEM, dsPICDEM.net, ECAN, In-Circuit Serial Programming, ICSP, Inter-Chip Connectivity, KleerNet, KleerNet logo, MiWi, MPASM, MPF, MPLAB Certified logo, MPLIB, MPLINK, MultiTRAK, NetDetach, Omniscient Code Generation, PICDEM, PICDEM.net, PICKit, PICtail, RightTouch logo, REAL ICE, SQI, Serial Quad I/O, Total Endurance, TSHARC, USBCheck, VariSense, ViewSpan, WiperLock, Wireless DNA, and ZENA are trademarks of Microchip Technology Incorporated in the U.S.A. and other countries.

SQTP is a service mark of Microchip Technology Incorporated in the U.S.A.

Silicon Storage Technology is a registered trademark of Microchip Technology Inc. in other countries.

GestIC is a registered trademarks of Microchip Technology Germany II GmbH & Co. KG, a subsidiary of Microchip Technology Inc., in other countries.

All other trademarks mentioned herein are property of their respective companies.

© 2015, Microchip Technology Incorporated, Printed in the U.S.A., All Rights Reserved.

ISBN: 9781632770332

**QUALITY MANAGEMENT SYSTEM
CERTIFIED BY DNV
= ISO/TS 16949 =**

Microchip received ISO/TS-16949:2009 certification for its worldwide headquarters, design and wafer fabrication facilities in Chandler and Tempe, Arizona; Gresham, Oregon and design centers in California and India. The Company's quality system processes and procedures are for its PIC[®] MCUs and dsPIC[®] DSCs, KEELOQ[®] code hopping devices, Serial EEPROMs, microperipherals, nonvolatile memory and analog products. In addition, Microchip's quality system for the design and manufacture of development systems is ISO 9001:2000 certified.



Worldwide Sales and Service

AMERICAS

Corporate Office

2355 West Chandler Blvd.
Chandler, AZ 85224-6199

Tel: 480-792-7200

Fax: 480-792-7277

Technical Support:

[http://www.microchip.com/
support](http://www.microchip.com/support)

Web Address:

www.microchip.com

Atlanta

Duluth, GA

Tel: 678-957-9614

Fax: 678-957-1455

Austin, TX

Tel: 512-257-3370

Boston

Westborough, MA

Tel: 774-760-0087

Fax: 774-760-0088

Chicago

Itasca, IL

Tel: 630-285-0071

Fax: 630-285-0075

Cleveland

Independence, OH

Tel: 216-447-0464

Fax: 216-447-0643

Dallas

Addison, TX

Tel: 972-818-7423

Fax: 972-818-2924

Detroit

Novi, MI

Tel: 248-848-4000

Houston, TX

Tel: 281-894-5983

Indianapolis

Noblesville, IN

Tel: 317-773-8323

Fax: 317-773-5453

Los Angeles

Mission Viejo, CA

Tel: 949-462-9523

Fax: 949-462-9608

New York, NY

Tel: 631-435-6000

San Jose, CA

Tel: 408-735-9110

Canada - Toronto

Tel: 905-673-0699

Fax: 905-673-6509

ASIA/PACIFIC

Asia Pacific Office

Suites 3707-14, 37th Floor
Tower 6, The Gateway
Harbour City, Kowloon

Hong Kong

Tel: 852-2943-5100

Fax: 852-2401-3431

Australia - Sydney

Tel: 61-2-9868-6733

Fax: 61-2-9868-6755

China - Beijing

Tel: 86-10-8569-7000

Fax: 86-10-8528-2104

China - Chengdu

Tel: 86-28-8665-5511

Fax: 86-28-8665-7889

China - Chongqing

Tel: 86-23-8980-9588

Fax: 86-23-8980-9500

China - Dongguan

Tel: 86-769-8702-9880

China - Hangzhou

Tel: 86-571-8792-8115

Fax: 86-571-8792-8116

China - Hong Kong SAR

Tel: 852-2943-5100

Fax: 852-2401-3431

China - Nanjing

Tel: 86-25-8473-2460

Fax: 86-25-8473-2470

China - Qingdao

Tel: 86-532-8502-7355

Fax: 86-532-8502-7205

China - Shanghai

Tel: 86-21-5407-5533

Fax: 86-21-5407-5066

China - Shenyang

Tel: 86-24-2334-2829

Fax: 86-24-2334-2393

China - Shenzhen

Tel: 86-755-8864-2200

Fax: 86-755-8203-1760

China - Wuhan

Tel: 86-27-5980-5300

Fax: 86-27-5980-5118

China - Xian

Tel: 86-29-8833-7252

Fax: 86-29-8833-7256

ASIA/PACIFIC

China - Xiamen

Tel: 86-592-2388138

Fax: 86-592-2388130

China - Zhuhai

Tel: 86-756-3210040

Fax: 86-756-3210049

India - Bangalore

Tel: 91-80-3090-4444

Fax: 91-80-3090-4123

India - New Delhi

Tel: 91-11-4160-8631

Fax: 91-11-4160-8632

India - Pune

Tel: 91-20-3019-1500

Japan - Osaka

Tel: 81-6-6152-7160

Fax: 81-6-6152-9310

Japan - Tokyo

Tel: 81-3-6880-3770

Fax: 81-3-6880-3771

Korea - Daegu

Tel: 82-53-744-4301

Fax: 82-53-744-4302

Korea - Seoul

Tel: 82-2-554-7200

Fax: 82-2-558-5932 or

82-2-558-5934

Malaysia - Kuala Lumpur

Tel: 60-3-6201-9857

Fax: 60-3-6201-9859

Malaysia - Penang

Tel: 60-4-227-8870

Fax: 60-4-227-4068

Philippines - Manila

Tel: 63-2-634-9065

Fax: 63-2-634-9069

Singapore

Tel: 65-6334-8870

Fax: 65-6334-8850

Taiwan - Hsin Chu

Tel: 886-3-5778-366

Fax: 886-3-5770-955

Taiwan - Kaohsiung

Tel: 886-7-213-7828

Taiwan - Taipei

Tel: 886-2-2508-8600

Fax: 886-2-2508-0102

Thailand - Bangkok

Tel: 66-2-694-1351

Fax: 66-2-694-1350

EUROPE

Austria - Wels

Tel: 43-7242-2244-39

Fax: 43-7242-2244-393

Denmark - Copenhagen

Tel: 45-4450-2828

Fax: 45-4485-2829

France - Paris

Tel: 33-1-69-53-63-20

Fax: 33-1-69-30-90-79

Germany - Dusseldorf

Tel: 49-2129-3766400

Germany - Munich

Tel: 49-89-627-144-0

Fax: 49-89-627-144-44

Germany - Pforzheim

Tel: 49-7231-424750

Italy - Milan

Tel: 39-0331-742611

Fax: 39-0331-466781

Italy - Venice

Tel: 39-049-7625286

Netherlands - Drunen

Tel: 31-416-690399

Fax: 31-416-690340

Poland - Warsaw

Tel: 48-22-3325737

Spain - Madrid

Tel: 34-91-708-08-90

Fax: 34-91-708-08-91

Sweden - Stockholm

Tel: 46-8-5090-4654

UK - Wokingham



Tel: 44-118-921-5800

Fax: 44-118-921-5820

01/27/15

Looking for pricing, stock, or lifecycle information?

Click below to explore more details on WIN SOURCE:

-  [View CAP1126-1-AP-TR on WIN SOURCE](#)
-  [Microchip Technology](#) Information

Optimize Your Supply Chain with WIN SOURCE Solutions

-  Global Sourcing Solution
-  Obsolete Management
-  Cost Control Management
-  Shortage Management
-  Alternative Solution
-  Excess Inventory Management