



**THE DATASHEET OF  
BD34700FV-E2**



Sound Processors for Home Theater Systems

# 4ch Sound Processor with Built-in Micro-step Volume

**BD34700FV**

**General Description**

The BD34700FV is a 4ch independent volume system. Micro-step volume can reduce the switching pop noise when volume changes, so it can achieve a high-quality set. It is most suitable for subvolume of the multi channel volume such as AV receivers, but is most suitable for main volume of simple systems such as 2ch.

**Key Features**

- Total harmonic distortion: 0.0004%(Typ.)
- Maximum output voltage: 4.2Vrms(Typ.)
- Output noise voltage: 1.5uVrms(Typ.)
- Residual output noise voltage: 1.0uVrms(Typ.)
- Cross-talk between channels: -105dB(Typ.)

**Features**

- Micro-step volume can reduce the switching pop noise when volume changes.
- Micro-step volume can reduce the capacitor for the DC offset cut
- 2-wire serial bus control, corresponding to 3.3/5V.
- It is controllable to two chips on the same serial bus by using chip select terminal.

**Applications**

- Most suitable for the AV receivers, home theater and mini-component systems

**Package**

SSOP-B40

**W(Typ.) x D(Typ.) x H(Max.)**

13.60mm x 7.80mm x 2.00mm

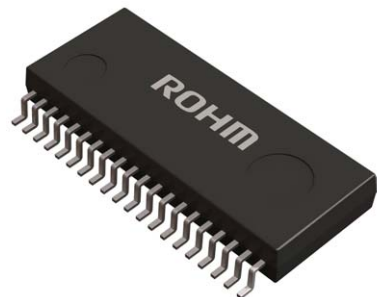

SSOP-B40

**Typical Application Circuit**

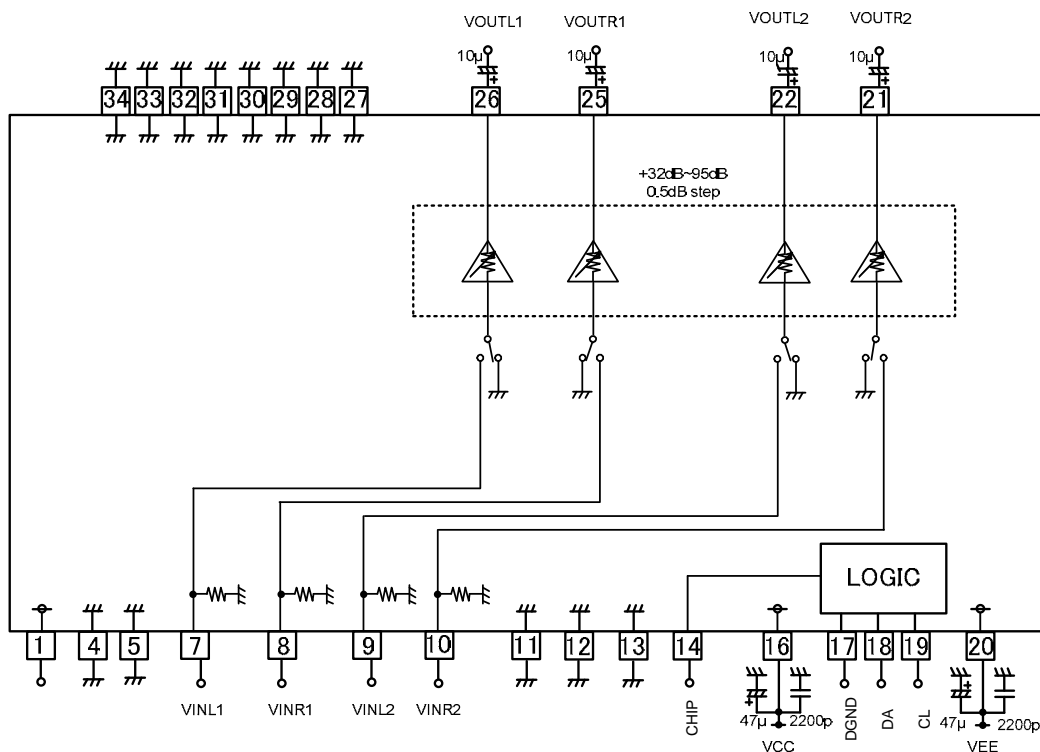

Figure 1. Application Circuit

○Product structure : Silicon monolithic integrated circuit ○This product is not designed protection against radioactive rays



## Description of terminal

Terminal Number	Symbol	Function	Terminal Number	Symbol	Function
1	VEES	Negative power supply terminal	21	VOUTR2	Volume output terminal R2
2	TEST	TEST terminal	22	VOUTL2	Volume output terminal L2
3	TEST	TEST terminal	23	TEST	TEST terminal
4	GND	Analog ground terminal	24	TEST	TEST terminal
5	GND	Analog ground terminal	25	VOUTR1	Volume output terminal R1
6	NC	Non connection	26	VOUTL1	Volume output terminal L1
7	VINL1	Volume input terminal L1	27	GND	Analog ground terminal
8	VINR1	Volume input terminal R1	28	GND	Analog ground terminal
9	VINL2	Volume input terminal L2	29	GND	Analog ground terminal
10	VINR2	Volume input terminal R2	30	GND	Analog ground terminal
11	GND	Analog ground terminal	31	GND	Analog ground terminal
12	GND	Analog ground terminal	32	GND	Analog ground terminal
13	GND	Analog ground terminal	33	GND	Analog ground terminal
14	CHIP	Chip select	34	GND	Analog ground terminal
15	NC	Non connection	35	NC	Non connection
16	VCC	Positive power supply terminal	36	NC	Non connection
17	DGND	Digital ground terminal	37	TEST	TEST terminal
18	DA	Data and latch input terminal	38	TEST	TEST terminal
19	CL	Clock input terminal	39	TEST	TEST terminal
20	VEE	Negative power supply terminal	40	TEST	TEST terminal

Block Diagram

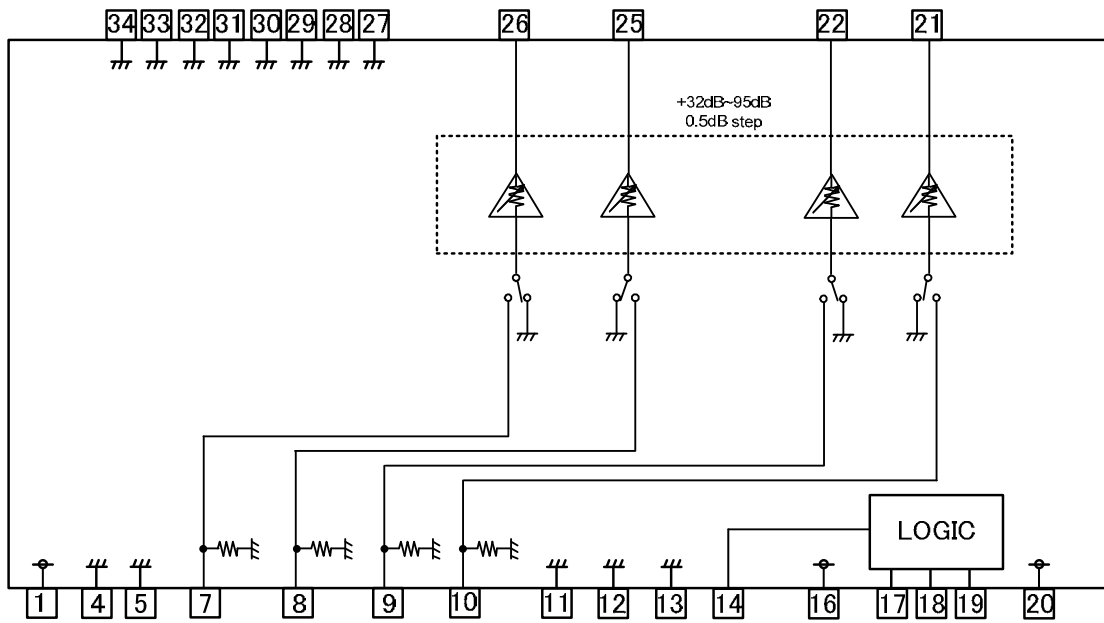

Figure 3. Block Diagram

## Absolute Maximum Ratings

Item	Symbol	Rating	Unit
Positive power supply	VCC	+7.75 (Note1)	V
Negative power supply	VEE	-7.75 (Note1)	V
Power dissipation	Pd	1.12 (Note2)	W
Input voltage	Vin	Vee-0.2 to Vcc+0.2	V
Operating temperature	Topr	-40 to +85 (Note3)	°C
Storage temperature	Tstg	-55 to +150	°C

(Note1) The maximum voltage that can be applied based on GND.

(Note2) This value decreases 9.0mW/°C for Ta=25°C or more. A standard board, 70×70×1.6 mm, shall be mounted.

(Note3) If it within operation voltage range, circuit functions operation is guaranteed within operation temp.

**Caution:** Operating the IC over the absolute maximum ratings may damage the IC. The damage can either be a short circuit between pins or an open circuit between pins and the internal circuitry. Therefore, it is important to consider circuit protection measures, such as adding a fuse, in case the IC is operated over the absolute maximum ratings.

## Operating Condition

Item	Symbol	Rating	Unit
Positive power supply	VCC	+6.5 to +7.5 (Note4,5)	V
Negative power supply	VEE	-6.5 to -7.5 (Note4,5)	V

(Note4) Applying a voltage based on GND.

(Note5) Within operation temp range, basic circuit function Operation is guaranteed within operation voltage range.

But please confirm set up of constant and element, voltage set up and temp set up on use.

Please watch out except condition stipulated by electrical characteristics within the range,

It cannot guarantee standard value of electrical characteristics. But it retains original function

**Electrical characteristic**

Unless specified particularly, Ta=25°C, Vcc=7V, Vee=-7V, f=1kHz, Vin=1Vrms, RL=10kΩ,  
Stereo input =VINL1,VINR1, Stereo output=VOU1L1,VOU1R1, Volume=0dB.

	Item	Symbol	Limit			Unit	Conditions
			Min.	Typ.	Max.		
TOTAL	Positive circuit current	Iqp	-	22	44	mA	No signal
	Negative circuit current	Iqn	-44	-22	-	mA	No signal
	Output voltage gain	Gv	-1.5	0	1.5	dB	21,22,25,26pin output
	Channel balance	CB	-0.5	0	0.5	dB	L Channel reference,
	Total harmonic distortion	THD	-	0.0004	0.02	%	BW=400 to 30kHz 21,22,25,26pin output
	Maximum output voltage	Vom	3.8	4.2	-	Vrms	THD=1%, VOLUME=+10dB 21,22,25,26pin output
	Output noise voltage *	Vno	-	1.5	10	μVrms	Rg=0Ω, BW=IHF-A 21,22,25,26pin output
	Residual output noise voltage *	Vnor	-	1	8	μVrms	Volume=Mute, Rg=0Ω, BW=IHF-A 21,22,25,26pin output
	Cross-talk between channels *	CT	-	-105	-80	dB	Rg=0Ω, BW=IHF-A 21,22,25,26pin output
	Input impedance	Rin	32	47	62	kΩ	7 to 10pin
VOLUME	Maximum attenuation *	ATTmax	-	-115	-100	dB	Volume=Mute, BW=IHF-A

※VP-9690A(Average value detection, effective value display) filter by Panasonic is used for \* measurement.

Typical Performance Curve(s)

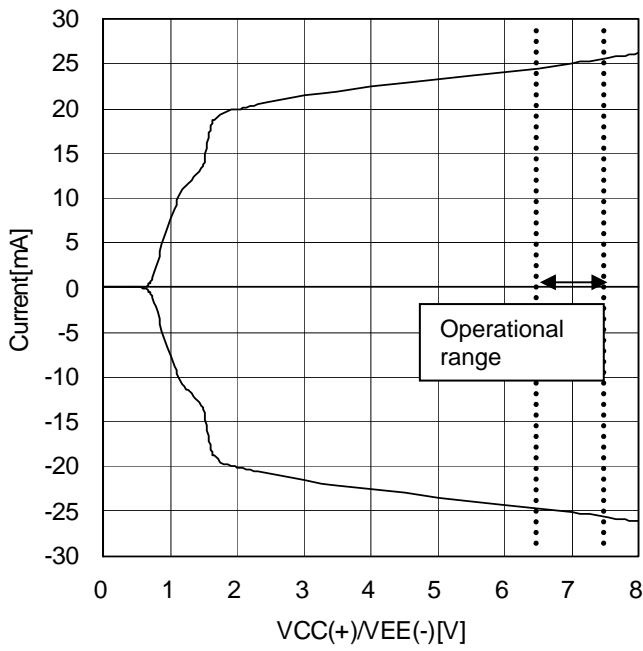

Figure 4. Circuit Currents vs. Circuit Voltage

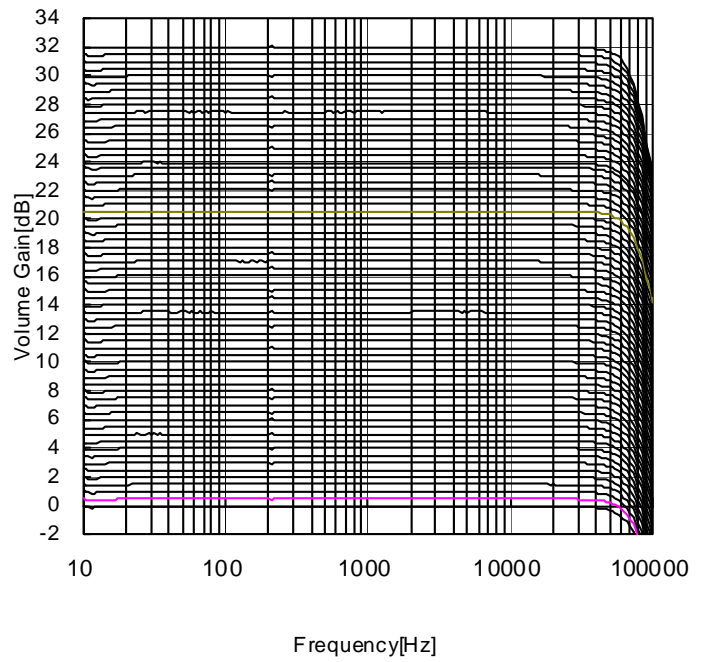

Figure 5. Volume Gain vs. Input Frequency (32dB to 0 dB setting)

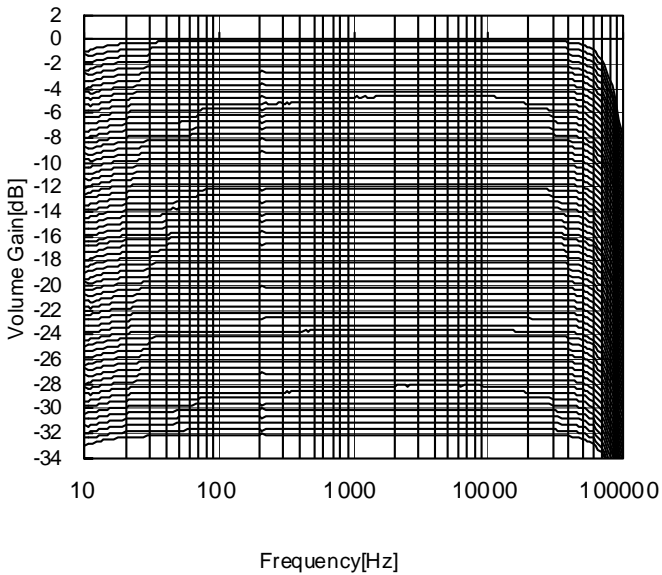

Figure 6. Volume Gain vs. Input Frequency (0dB to -32 dB setting)

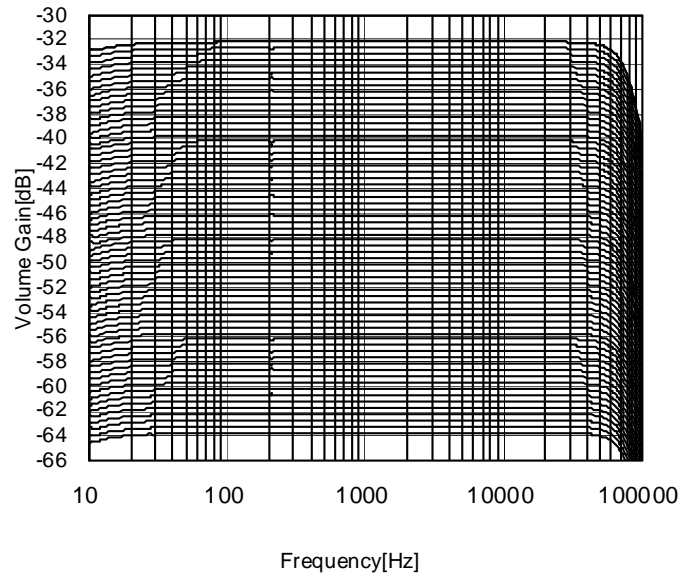

Figure 7. Volume Gain vs. Input Frequency (-32dB to -64 dB setting)

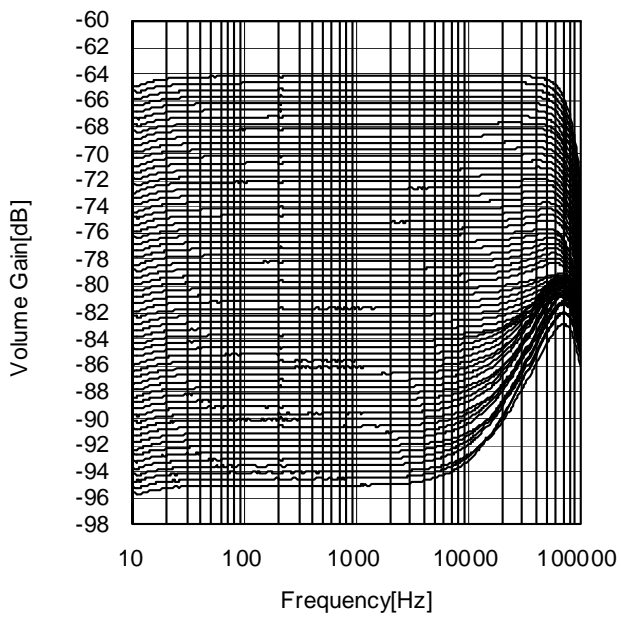

Figure 8. Volume Gain vs. Input Frequency (-64dB to -95 dB setting)

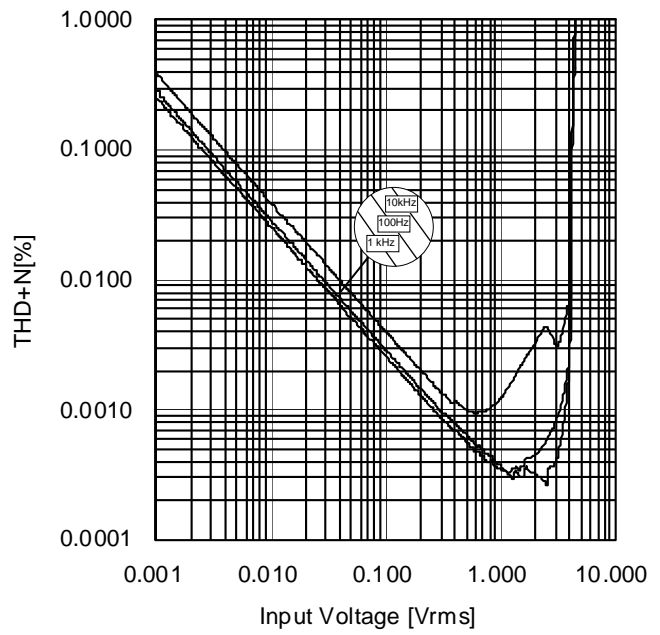

Figure 9. THD + N vs. Input Voltage

**Specifications for Control Signal**

(1) Timing of control signal

Data is read at a rising edge of clock.

Latch is read at a falling edge of clock. And Data on the latest 16bit are taken in the inside of this IC.

Be sure to set DA and CL to LOW after latching.

1byte=16bit

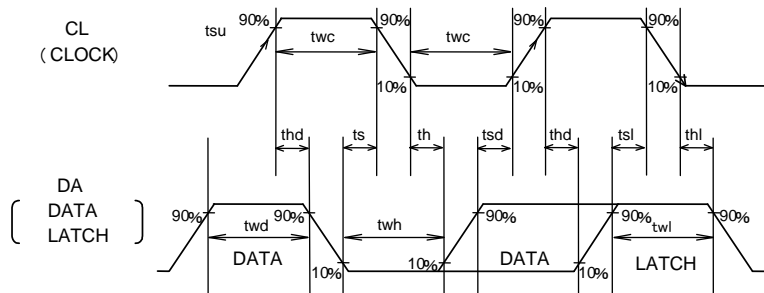

Figure 10. The timing definition of the control signal.

Item	Symbol	Limit			Unit
		Min.	Typ.	Max.	
Clock width	twc	1.0	-	-	μsec
Data width	twd	1.0	-	-	μsec
Latch width	twl	1.0	-	-	μsec
Low hold width	twh	1.0	-	-	μsec
Data setup time (DATA→CLK)	tsd	0.5	-	-	μsec
Data hold time (CLK→DATA)	thd	0.5	-	-	μsec
Latch setup time (CLK→LATCH)	tsl	0.5	-	-	μsec
Latch hold time	thl	0.5	-	-	μsec
Latch Low setup time	ts	0.5	-	-	μsec
Latch Low hold time	th	0.5	-	-	μsec

(2) Voltage of control signal (CL, DA, CHIP)

Item	Conditions	Limit			Unit
		Min.	Typ.	Max. (<Vcc)	
High input voltage	Vcc=+6.5 to +7.5V	2.3	-	5.5	V
Low input voltage	Vee=-6.5 to -7.5V	0	-	1.0	V

(3) Basic Structure of Control Data

← Input Direction

D15	D14	D13	D12	D11	D10	D9	D8	D7	D6	D5	D4	D3	D2	D1	D0
Data												Select Address			

(4) Table of Control Data

←Input Direction

Select Address No.	D15	D14	D13	D12	D11	D10	D9	D8	D7	D6	D5	D4	D3	D2	D1	D0	
0	0	0	0	0	0	0	0	0	0	0	1	0	0	Chip Select	0	0	
1	0	0	0	0	0	0	0	0	0	0	0	0	0		0	1	
2	0	0	MUTE on/off L2,R2	0	0	0	0	MUTE on/off L1,R1	0	0	0	0	0		1	0	
3	Volume channel Select		Volume										0		1	1	
7	A→B switch-time		B→A switch-time		Base clock	0	0	System reset	0	0	1	1	1				
													BD3843FS (6ch Selector IC)	*	1	0	0
													BD3841FS (9ch Selector IC)	*	1	0	1
													BD3812F (2ch volume IC)	*	1	1	*

- Serial control lines can be shared with BD34701KS2(8ch Volume IC) to set different data by chip select.
- Serial control lines can be shared with BD3843FS(6ch selector IC), BD3841FS(9ch selector IC) and BD3812F(2ch volume IC).
- Initialize all data at every turning on the power supply.

(Example)

←Input direction

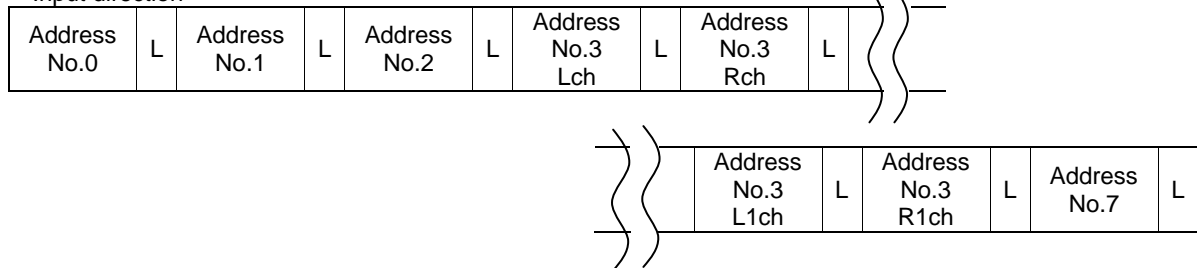

- At the second time after turning on the power supply, eight any data to be changed.

(5) Chip Select Setting Table

CHIP terminal condition	D2
0 (LOW)	0
1 (HIGH)	1

BD34700FV can be operated in combination with another by setting the CHIP terminal.

Select Address No.2 Setting Table																															
Function & Setting		D15	D14	D13	D12	D11	D10	D9	D8	D7	D6	D5	D4	D3	D2	D1	D0														
MUTE ON/OFF L2,R2ch	ON	0	0	0	0	0	0	0	MUTE on/off L1,R1	0	0	0	0	0	Chip Select	1	0														
	OFF			1																											
MUTE ON/OFF L1,R1ch	ON			0					0									MUTE on/off L2,R2	0	0	0	0	0	0	0	0	0	0	Chip Select	1	0
	OFF																						1								

 : Initial condition

Select Address No.3 Setting Table

Function & Setting		D15	D14	D13	D12	D11	D10	D9	D8	D7	D6	D5	D4	D3	D2	D1	D0			
Volume Channel Select	Non select	0	0	0	Volume												0	Chip Select	1	1
	R2	0	1	0																
	L2	0		1																
	R1	1		0																
	L1	1		1																
Volume	MUTE	Volume Channel Select			1	1	1	1	1	1	1	1	1	0	Chip Select	1	1			
	Prohibition				1	1	1	1	1	1	1	0								
					:	:	:	:	:	:	:	:								
	+32.0dB				0	1	0	0	0	0	0	0	0					0	0	1
	+31.5dB				0	0	1	1	1	1	1	1	1					1	1	1
	+31.0dB				0	0	1	1	1	1	1	1	1					1	0	0
	+30.5dB				0	0	1	1	1	1	1	0	1					0	1	0
	+30.0dB				0	0	1	1	1	1	1	0	1					0	0	0
	+29.5dB				0	0	1	1	1	0	1	1	0					1	1	1
	+29.0dB				0	0	1	1	1	0	1	0	1					0	0	0
	+28.5dB				0	0	1	1	1	0	0	1	0					0	1	1
	+28.0dB				0	0	1	1	1	0	0	0	0					0	0	0
	+27.5dB				0	0	1	1	0	1	1	1	1					1	1	1
	+27.0dB				0	0	1	1	0	1	1	1	0					1	0	0
	+26.5dB				0	0	1	1	0	1	0	1	0					1	0	1
	+26.0dB				0	0	1	1	0	1	0	1	0					0	0	0
	+25.5dB				0	0	1	1	0	0	1	1	0					1	1	1
	+25.0dB				0	0	1	1	0	0	0	1	0					0	1	0
	+24.5dB				0	0	1	1	0	0	0	0	0					0	1	0
	+24.0dB				0	0	1	1	0	0	0	0	0					0	0	0
	+23.5dB				0	0	1	0	1	1	1	1	1					1	1	1
	+23.0dB				0	0	1	0	1	1	1	1	1					0	0	0
	+22.5dB				0	0	1	0	1	1	0	1	0					1	0	1
	+22.0dB				0	0	1	0	1	1	0	1	0					0	0	0
	+21.5dB				0	0	1	0	1	0	1	0	1					0	1	1
	+21.0dB				0	0	1	0	1	0	1	0	1					0	1	0
	+20.5dB				0	0	1	0	1	0	0	0	0					0	1	0
	+20.0dB				0	0	1	0	1	0	0	0	0					0	0	0
	+19.5dB				0	0	1	0	0	1	1	1	1					1	1	1
	+19.0dB				0	0	1	0	0	1	1	0	1					0	0	0
	+18.5dB				0	0	1	0	0	1	0	1	0					0	1	1
	+18.0dB				0	0	1	0	0	1	0	0	1					0	0	0
+17.5dB	0	0	1	0	0	0	0	1	1	1	1	1								
+17.0dB	0	0	1	0	0	0	0	0	1	0	0	0								
+16.5dB	0	0	1	0	0	0	0	0	0	0	1	0								
+16.0dB	0	0	1	0	0	0	0	0	0	0	0	1								
+15.5dB	0	0	0	1	1	1	1	1	1	1	1	1								

 : Initial condition

Select Address No.3 Setting Table

Function & Setting	D15	D14	D13	D12	D11	D10	D9	D8	D7	D6	D5	D4	D3	D2	D1	D0		
Volume	Volume Channel Select			1	+15.0dB	0	0	0	1	1	1	1	0	0	Chip Select	1	1	
					+14.5dB	0	0	0	1	1	1	0	1					
					+14.0dB	0	0	0	1	1	1	0	0					
					+13.5dB	0	0	0	1	1	0	1	1					
					+13.0dB	0	0	0	1	1	0	1	0					
					+12.5dB	0	0	0	1	1	0	0	1					
					+12.0dB	0	0	0	1	1	0	0	0					
					+11.5dB	0	0	0	1	0	1	1	1					
					+11.0dB	0	0	0	1	0	1	1	0					
					+10.5dB	0	0	0	1	0	1	0	1					
					+10.0dB	0	0	0	1	0	1	0	0					
					+9.5dB	0	0	0	1	0	0	1	1					
					+9.0dB	0	0	0	1	0	0	1	0					
					+8.5dB	0	0	0	1	0	0	0	1					
					+8.0dB	0	0	0	1	0	0	0	0					
					+7.5dB	0	0	0	0	1	1	1	1					
					+7.0dB	0	0	0	0	1	1	1	0					
				+6.5dB	0	0	0	0	1	1	0	1						
				+6.0dB	0	0	0	0	1	1	0	0						
				+5.5dB	0	0	0	0	1	0	1	1						
				+5.0dB	0	0	0	0	1	0	1	0						
				+4.5dB	0	0	0	0	1	0	0	1						
				+4.0dB	0	0	0	0	1	0	0	0						
				+3.5dB	0	0	0	0	0	1	1	1						
				+3.0dB	0	0	0	0	0	1	1	0						
				+2.5dB	0	0	0	0	0	1	0	1						
				+2.0dB	0	0	0	0	0	1	0	0						
				+1.5dB	0	0	0	0	0	0	1	1						
				+1.0dB	0	0	0	0	0	0	1	0						
				+0.5dB	0	0	0	0	0	0	0	1						
				Prohibition	0	0	0	0	0	0	0	0	0					
				0	-0dB	0	0	0	0	0	0	0	0					0
					-0.5dB	0	0	0	0	0	0	0	0					1
					-1.0dB	0	0	0	0	0	0	0	1					0
					-1.5dB	0	0	0	0	0	0	0	1					1
-2.0dB	0	0	0		0	0	0	1	0	0								
-2.5dB	0	0	0		0	0	0	1	0	1								
-3.0dB	0	0	0		0	0	0	1	1	0								
-3.5dB	0	0	0		0	0	0	1	1	1								
-4.0dB	0	0	0		0	0	1	0	0	0								
-4.5dB	0	0	0		0	0	1	0	0	1								
-5.0dB	0	0	0	0	0	1	0	1	0									
-5.5dB	0	0	0	0	0	1	0	1	1									
-6.0dB	0	0	0	0	0	1	1	0	0									
-6.5dB	0	0	0	0	0	1	1	0	1									
-7.0dB	0	0	0	0	0	1	1	1	0									
-7.5dB	0	0	0	0	0	1	1	1	1									





Select Address No.3 Setting Table

Function & Setting	D15	D14	D13	D12	D11	D10	D9	D8	D7	D6	D5	D4	D3	D2	D1	D0	
Volume	Volume Channel Select	0	0	0	-55.0dB	0	1	1	0	1	1	1	0	0	Chip Select	1	1
					-55.5dB	0	1	1	0	1	1	1	1				
					-56.0dB	0	1	1	1	0	0	0	0				
					-56.5dB	0	1	1	1	0	0	0	1				
					-57.0dB	0	1	1	1	0	0	1	0				
					-57.5dB	0	1	1	1	0	0	1	1				
					-58.0dB	0	1	1	1	0	1	0	0				
					-58.5dB	0	1	1	1	0	1	0	1				
					-59.0dB	0	1	1	1	0	1	1	0				
					-59.5dB	0	1	1	1	0	1	1	1				
					-60.0dB	0	1	1	1	1	0	0	0				
					-60.5dB	0	1	1	1	1	0	0	1				
					-61.0dB	0	1	1	1	1	0	1	0				
					-61.5dB	0	1	1	1	1	0	1	1				
					-62.0dB	0	1	1	1	1	1	0	0				
					-62.5dB	0	1	1	1	1	1	0	1				
					-63.0dB	0	1	1	1	1	1	1	0				
					-63.5dB	0	1	1	1	1	1	1	1				
					-64.0dB	1	0	0	0	0	0	0	0				
					-64.5dB	1	0	0	0	0	0	0	1				
					-65.0dB	1	0	0	0	0	0	1	0				
					-65.5dB	1	0	0	0	0	0	1	1				
					-66.0dB	1	0	0	0	0	1	0	0				
					-66.5dB	1	0	0	0	0	1	0	1				
					-67.0dB	1	0	0	0	0	1	1	0				
					-67.5dB	1	0	0	0	0	1	1	1				
					-68.0dB	1	0	0	0	1	0	0	0				
					-68.5dB	1	0	0	0	1	0	0	1				
					-69.0dB	1	0	0	0	1	0	1	0				
					-69.5dB	1	0	0	0	1	0	1	1				
					-70.0dB	1	0	0	0	1	1	0	0				
					-70.5dB	1	0	0	0	1	1	0	1				
					-71.0dB	1	0	0	0	1	1	1	0				
					-71.5dB	1	0	0	0	1	1	1	1				
					-72.0dB	1	0	0	1	0	0	0	0				
					-72.5dB	1	0	0	1	0	0	0	1				
-73.0dB	1	0	0	1	0	0	1	0									
-73.5dB	1	0	0	1	0	0	1	1									
-74.0dB	1	0	0	1	0	1	0	0									
-74.5dB	1	0	0	1	0	1	0	1									
-75.0dB	1	0	0	1	0	1	1	0									
-75.5dB	1	0	0	1	0	1	1	1									
-76.0dB	1	0	0	1	1	0	0	0									
-76.5dB	1	0	0	1	1	0	0	1									
-77.0dB	1	0	0	1	1	0	1	0									
-77.5dB	1	0	0	1	1	0	1	1									
-78.0dB	1	0	0	1	1	1	0	0									

Select Address No.3 Setting Table

Function & Setting	D15	D14	D13	D12	D11	D10	D9	D8	D7	D6	D5	D4	D3	D2	D1	D0									
Volume	-78.5dB			0	1	0	0	1	1	1	0	1	0	Chip Select	1	1									
					1	0	0	1	1	1	1	0													
					1	0	0	1	1	1	1	1													
					1	0	1	0	0	0	0	0													
					1	0	1	0	0	0	0	1													
					1	0	1	0	0	0	1	1													
					1	0	1	0	0	1	0	0													
					1	0	1	0	0	1	0	1													
					1	0	1	0	0	1	1	0													
					1	0	1	0	0	1	1	1													
					1	0	1	0	1	0	0	0													
					1	0	1	0	1	1	1	0													
					1	0	1	0	1	0	0	1													
					1	0	1	0	1	0	1	0													
					1	0	1	0	1	0	1	1													
					1	0	1	0	1	1	1	0													
					1	0	1	0	1	1	1	0													
					1	0	1	0	1	1	1	1													
					1	0	1	0	1	1	1	1													
					1	0	1	0	1	1	0	0													
					1	0	1	0	1	1	0	1													
					1	0	1	0	1	1	1	0													
					1	0	1	0	1	1	1	1													
					1	0	1	0	1	1	1	1													
					1	0	1	0	1	1	1	1													
					Prohibition	:	:	:	:	:	:	:					:	:	:	:	:	:	:	:	:
						1	1	1	1	1	1	1					1	1	1	1	1				

Select Address No.7 Setting Table

Function & Setting		D15	D14	D13	D12	D11	D10	D9	D8	D7	D6	D5	D4	D3	D2	D1	D0															
A→B switching-time	11msec	0	0	0	B→A switching-time			Base clock	0	0	System Reset	0	0	1	Chip Select	1	1															
	5msec	0	0	1																												
	7msec	0	1	0																												
	14msec	0	1	1																												
	3msec	1	0	0																												
	2msec	1	0	1																												
	Prohibition	1	1	0																												
1		1	1																													
B→A switching-time	11msec	A→B switching-time			0	0	0	Base clock	0	0	System Reset	0	0	1	Chip Select	1	1															
	5msec				0	0	1																									
	7msec				0	1	0																									
	14msec				0	1	1																									
	3msec				1	0	0																									
	2msec				1	0	1																									
	Prohibition				1	1	0																									
1		1	1																													
Base clock	x1	A→B switching-time			B→A switching-time			0	Base clock	0	System Reset	0	0	1	Chip Select	1	1															
	x1/2							1																								
System Reset	Normal							A→B switching-time										B→A switching-time			Base clock	0	0	System Reset	0	0	1	Chip Select	1	1		
	Reset																					1										

 : Initial condition

Volume changing needs the time that is following Figure. (Ex. It selected 11msec, 22msec need.)

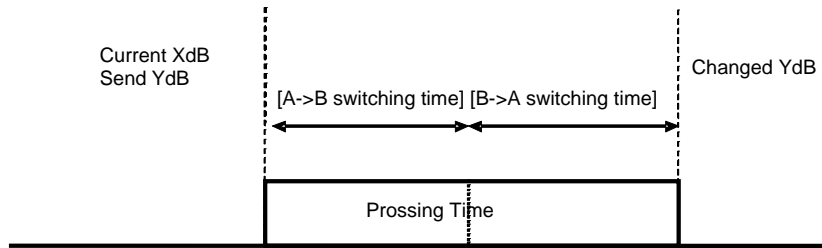

Figure 11. About [A→B switching-time] [B→A switching-time]

Base clock is able to change Internal Oscillator Frequency. For example, when Base clock select x1/2, A->B and B->A switching time is to be two times. (ex. 11msec->22msec)

oCaution on send data

When send the same channel data among the switching process, internal operation is as below.

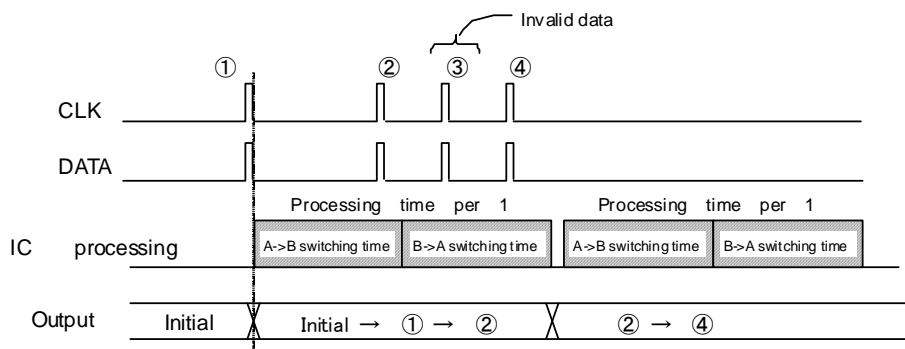

Figure 12. The switching process with send data

②data is sent during A -> B switching time, it is valid.

③data and ④data are sent during B -> A switching time, it is valid at the next processing time.

But ③data is replaced by ④data.

oAbout pop noise in gain changing

The level of the pop noise sometimes varies in the difference in output DC offset of the inside condition A and B.

Application Circuit Diagram

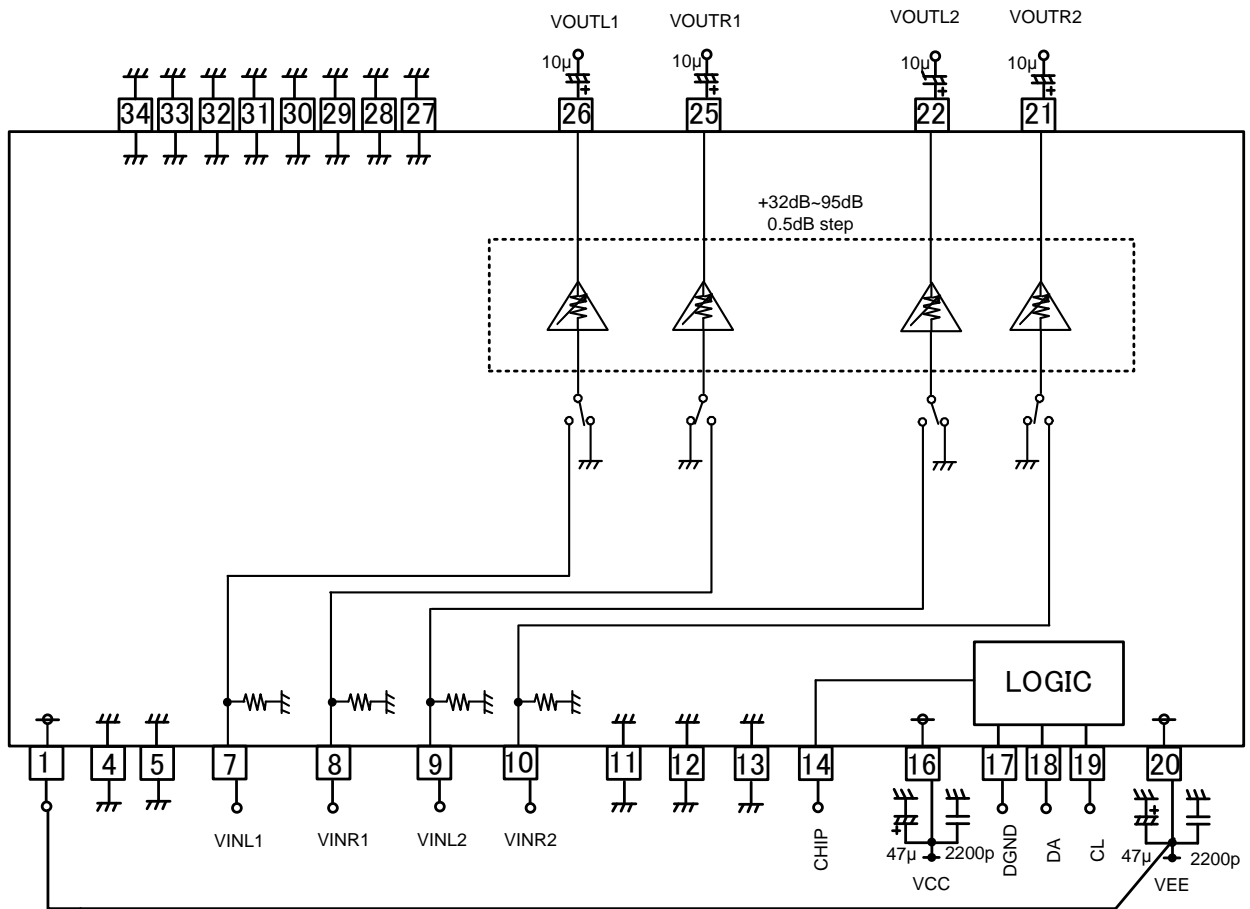

Figure 13. Application Circuit Diagram

Notes on wiring

- ① GND shall be wired from reference point and thicken.
- ② Wiring pattern of CL and DA shall be away from that of analog unit and cross-talk shall not be acceptable.
- ③ Lines of CL and DA of shall not be parallel if possible. The lines shall be shielded, if they are adjacent to each other.
- ④ Please pay attention the wiring pattern of the input terminal of the input selector to the cross talk. Recommend that wiring period is shielded.
- ⑤ Please connect the decoupling capacitor of a power supply in the shortest distance as much as possible to VCC and GND, VEE.
- ⑥ 1pin have to connect to 20-pin(VEE), if you don't connect like as this note, IC may occurred "latch-up or ESD damaged".

Power Dissipation

About the thermal design by the IC  
Characteristics of an IC have a great deal to do with the temperature at which it is used, and exceeding absolute maximum ratings may degrade and destroy elements. Careful consideration must be given to the heat of the IC from the two standpoints of immediate damage and long-term reliability of operation.

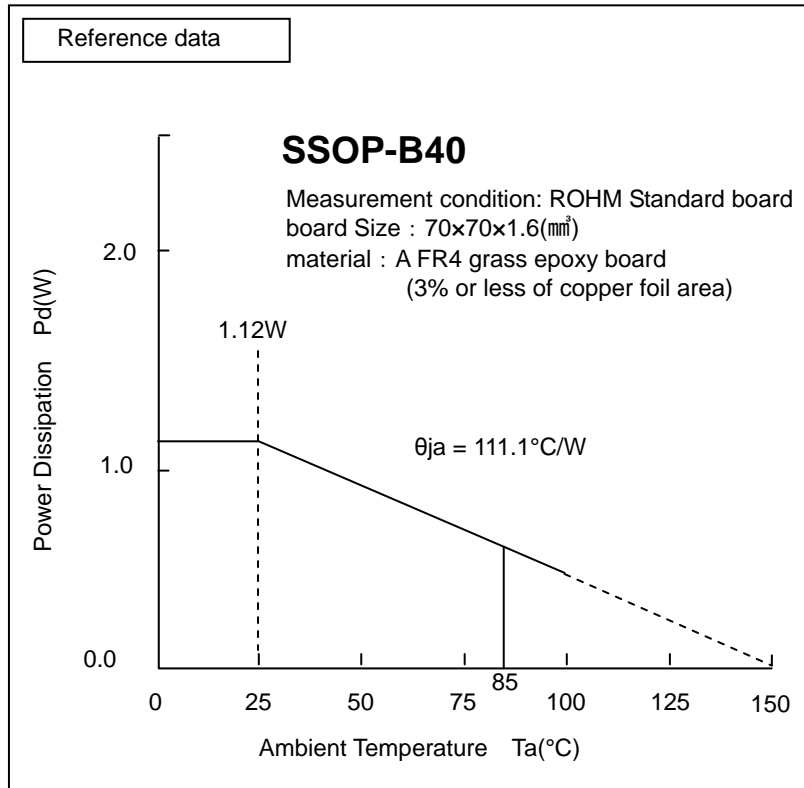

Figure 14. Temperature Derating Curve

Note) Value is actual measurements and is not guaranteed.

Power dissipation values vary according to the board on which the IC is mounted.

I/O equivalence circuit(s)

Terminal Number	Terminal Name	Terminal Voltage (V)	Equivalent Circuit	Description of terminal
1	VEES	-7		Negative power supply terminal
4 5 11 12 13 27 28 29 30 31 32 33 34	AGND	0		Analog ground terminals.
16 20	VCC VEE	+7 -7		Positive power supply terminal and Negative power supply terminal
17	DGND	0		Digital ground terminal.
18 19 14	DA CL CHIP	-		Input terminals for a clock and data.
21 22 25 26	VOUTR2 VOUTL2 VOUTR1 VOUTL1	0		Output terminals for analog sound signal.

Terminal Number	Terminal Name	Terminal Voltage (V)	Equivalent Circuit	Description of terminal
7 8 9 10	VINL1 VINR1 VINL2 VINR2	0		Input terminals for stereo sound signal. Input impedance is 47kΩ(Typ.).
2 3 23 24 37 38 39 40	TEST	0		TEST terminals

## Operational Notes

### 1. Reverse Connection of Power Supply

Connecting the power supply in reverse polarity can damage the IC. Take precautions against reverse polarity when connecting the power supply, such as mounting an external diode between the power supply and the IC's power supply terminals.

### 2. Power Supply Lines

Design the PCB layout pattern to provide low impedance supply lines. Separate the ground and supply lines of the digital and analog blocks to prevent noise in the ground and supply lines of the digital block from affecting the analog block. Furthermore, connect a capacitor to ground at all power supply pins. Consider the effect of temperature and aging on the capacitance value when using electrolytic capacitors.

### 3. VEE Voltage

Ensure that no pins are at a voltage below that of the VEE pin at any time, even during transient condition.

### 4. Ground Wiring Pattern

GND pins which are digital ground(17pin) and analog ground(4,5,11,12,13,27,28,29,30,31,32,33,34pin) are not connected inside LSI. These ground pins traces should be routed separately but connected to a single ground at the reference point of the application board. Also ensure that the ground traces of external components do not cause variations on the ground voltage. The ground lines must be as short and thick as possible to reduce line impedance.

### 5. Thermal Consideration

Should by any chance the power dissipation rating be exceeded the rise in temperature of the chip may result in deterioration of the properties of the chip. The absolute maximum rating of the Pd stated in this specification is when the IC is mounted on a 70mm x 70mm x 1.6mm glass epoxy board. In case of exceeding this absolute maximum rating, increase the board size and copper area to prevent exceeding the Pd rating.

### 6. Recommended Operating Conditions

These conditions represent a range within which the expected characteristics of the IC can be approximately obtained. The electrical characteristics are guaranteed under the conditions of each parameter.

### 7. Rush Current

When power is first supplied to the IC, it is possible that the internal logic may be unstable and inrush current may flow instantaneously due to the internal powering sequence and delays, especially if the IC has more than one power supply. Therefore, give special consideration to power coupling capacitance, power wiring, width of ground wiring, and routing of connections.

### 8. Operation Under Strong Electromagnetic Field

Operating the IC in the presence of a strong electromagnetic field may cause the IC to malfunction.

### 9. Testing on Application Boards

When testing the IC on an application board, connecting a capacitor directly to IC pin may subject the IC to stress. Always discharge capacitors completely after each process or step. The IC's power supply should always be turned off completely before connecting or removing it from the test setup during the inspection process. To prevent damage from static discharge, ground the IC during assembly and use similar precautions during transport and storage.

### 10. Inter-pin Short and Mounting Errors

Ensure that the direction and position are correct when mounting the IC on the PCB. Incorrect mounting may result in damaging the IC. Avoid nearby pins being shorted to each other especially to ground, power supply and output pin. Inter-pin shorts could be due to many reasons such as metal particles, water droplets (in very humid environment) and unintentional solder bridge deposited in between pins during assembly to name a few.

### 11. Unused Input Terminals

Because the input impedance of the terminal becomes 47kΩ when the signal input terminal makes a terminal open, the plunge noise from outside sometimes becomes a problem. Please connect the no using input pin to GND. And please open the no using output pin.

Operational Notes – continued 1

12. Regarding the Input Pin of the IC

This monolithic IC contains P+ isolation and P substrate layers between adjacent elements in order to keep them isolated. P-N junctions are formed at the intersection of the P layers with the N layers of other elements, creating a parasitic diode or transistor. For example (refer to figure below):

When  $V_{ee} > \text{Pin A}$  and  $V_{ee} > \text{Pin B}$ , the P-N junction operates as a parasitic diode.  
 When  $V_{ee} > \text{Pin B}$ , the P-N junction operates as a parasitic transistor.

Parasitic diodes inevitably occur in the structure of the IC. The operation of parasitic diodes can result in mutual interference among circuits, operational faults, or physical damage. Therefore, conditions that cause these diodes to operate, such as applying a voltage lower than the  $V_{ee}$  voltage to an input pin (and thus to the P substrate) should be avoided.

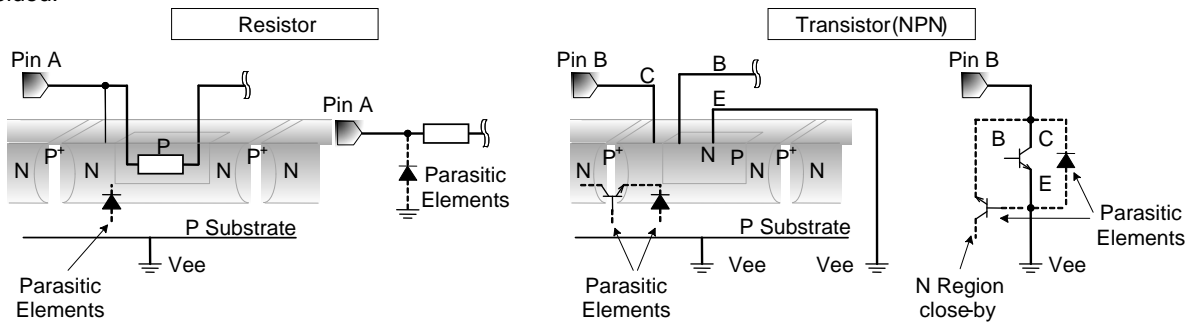

Figure 15. Example of monolithic IC structure

13. Ceramic Capacitor

When using a ceramic capacitor, determine the dielectric constant considering the change of capacitance with temperature and the decrease in nominal capacitance due to DC bias and others.

14. About power ON/OFF

1. At power ON/OFF, a pop sound will be generated and, therefore, use MUTE on the set.
2. When turning on power supplies,  $V_{ee}$  and  $V_{cc}$  should be powered on simultaneously or  $V_{ee}$  first; then followed by  $V_{cc}$ . If the  $V_{cc}$  side is started up first, an excessive current may pass  $V_{cc}$  through  $V_{ee}$ .

15. About function switching

When switching Input Selector, Mode selector or Input Gain, use MUTE on Volume.

16. Volume gain switching

In case of the boost of the volume when changing to the high gain which exceeds +20dB especially, the switching pop noise sometimes becomes big. In this case, we recommend changing every 1 dB step without changing a gain at once. Also, the pop noise sometimes can reduce by making micro-step volume switching time long, too.

Operational Notes – continued 2

17. Output load characteristic

The usages of load for output are below (reference). Please use the load more than 10 kΩ(TYP).

Output terminal

Terminal No.	Terminal Name	Terminal No.	Terminal Name
21	VOU2R2	25	VOU2R1
22	VOU2L2	26	VOU2L1

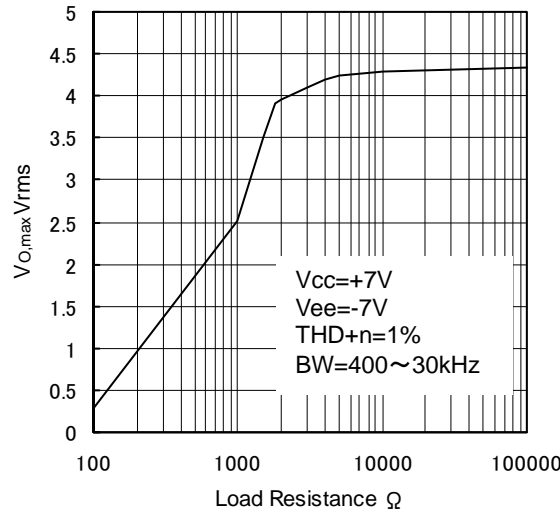

Figure 16. Output load characteristic at Vcc=+7V, Vee=-7V(Reference)

18. About TEST and N.C pins treatment

About the next pin of the TEST and NC designator, please handle it as follows

Pin number	How to countermeasure
2,3,37,38,39,40	Short to GND
6,15,23,24,35,36	OPEN (None connection)



## Revision History

Date	Revision	Changes
6.Aug.2014	001	New Release

# Notice

## Precaution on using ROHM Products

- Our Products are designed and manufactured for application in ordinary electronic equipments (such as AV equipment, OA equipment, telecommunication equipment, home electronic appliances, amusement equipment, etc.). If you intend to use our Products in devices requiring extremely high reliability (such as medical equipment <sup>(Note 1)</sup>, transport equipment, traffic equipment, aircraft/spacecraft, nuclear power controllers, fuel controllers, car equipment including car accessories, safety devices, etc.) and whose malfunction or failure may cause loss of human life, bodily injury or serious damage to property ("Specific Applications"), please consult with the ROHM sales representative in advance. Unless otherwise agreed in writing by ROHM in advance, ROHM shall not be in any way responsible or liable for any damages, expenses or losses incurred by you or third parties arising from the use of any ROHM's Products for Specific Applications.

(Note1) Medical Equipment Classification of the Specific Applications

JAPAN	USA	EU	CHINA
CLASS III	CLASS III	CLASS II b	CLASS III
CLASS IV		CLASS III	

- ROHM designs and manufactures its Products subject to strict quality control system. However, semiconductor products can fail or malfunction at a certain rate. Please be sure to implement, at your own responsibilities, adequate safety measures including but not limited to fail-safe design against the physical injury, damage to any property, which a failure or malfunction of our Products may cause. The following are examples of safety measures:
  - Installation of protection circuits or other protective devices to improve system safety
  - Installation of redundant circuits to reduce the impact of single or multiple circuit failure
- Our Products are designed and manufactured for use under standard conditions and not under any special or extraordinary environments or conditions, as exemplified below. Accordingly, ROHM shall not be in any way responsible or liable for any damages, expenses or losses arising from the use of any ROHM's Products under any special or extraordinary environments or conditions. If you intend to use our Products under any special or extraordinary environments or conditions (as exemplified below), your independent verification and confirmation of product performance, reliability, etc. prior to use, must be necessary:
  - Use of our Products in any types of liquid, including water, oils, chemicals, and organic solvents
  - Use of our Products outdoors or in places where the Products are exposed to direct sunlight or dust
  - Use of our Products in places where the Products are exposed to sea wind or corrosive gases, including Cl<sub>2</sub>, H<sub>2</sub>S, NH<sub>3</sub>, SO<sub>2</sub>, and NO<sub>2</sub>
  - Use of our Products in places where the Products are exposed to static electricity or electromagnetic waves
  - Use of our Products in proximity to heat-producing components, plastic cords, or other flammable items
  - Sealing or coating our Products with resin or other coating materials
  - Use of our Products without cleaning residue of flux (even if you use no-clean type fluxes, cleaning residue of flux is recommended); or Washing our Products by using water or water-soluble cleaning agents for cleaning residue after soldering
  - Use of the Products in places subject to dew condensation
- The Products are not subject to radiation-proof design.
- Please verify and confirm characteristics of the final or mounted products in using the Products.
- In particular, if a transient load (a large amount of load applied in a short period of time, such as pulse. is applied, confirmation of performance characteristics after on-board mounting is strongly recommended. Avoid applying power exceeding normal rated power; exceeding the power rating under steady-state loading condition may negatively affect product performance and reliability.
- De-rate Power Dissipation (Pd) depending on Ambient temperature (Ta). When used in sealed area, confirm the actual ambient temperature.
- Confirm that operation temperature is within the specified range described in the product specification.
- ROHM shall not be in any way responsible or liable for failure induced under deviant condition from what is defined in this document.

## Precaution for Mounting / Circuit board design

- When a highly active halogenous (chlorine, bromine, etc.) flux is used, the residue of flux may negatively affect product performance and reliability.
- In principle, the reflow soldering method must be used; if flow soldering method is preferred, please consult with the ROHM representative in advance.

For details, please refer to ROHM Mounting specification

**Precautions Regarding Application Examples and External Circuits**

1. If change is made to the constant of an external circuit, please allow a sufficient margin considering variations of the characteristics of the Products and external components, including transient characteristics, as well as static characteristics.
2. You agree that application notes, reference designs, and associated data and information contained in this document are presented only as guidance for Products use. Therefore, in case you use such information, you are solely responsible for it and you must exercise your own independent verification and judgment in the use of such information contained in this document. ROHM shall not be in any way responsible or liable for any damages, expenses or losses incurred by you or third parties arising from the use of such information.

**Precaution for Electrostatic**

This Product is electrostatic sensitive product, which may be damaged due to electrostatic discharge. Please take proper caution in your manufacturing process and storage so that voltage exceeding the Products maximum rating will not be applied to Products. Please take special care under dry condition (e.g. Grounding of human body / equipment / solder iron, isolation from charged objects, setting of Ionizer, friction prevention and temperature / humidity control).

**Precaution for Storage / Transportation**

1. Product performance and soldered connections may deteriorate if the Products are stored in the places where:
  - [a] the Products are exposed to sea winds or corrosive gases, including Cl<sub>2</sub>, H<sub>2</sub>S, NH<sub>3</sub>, SO<sub>2</sub>, and NO<sub>2</sub>
  - [b] the temperature or humidity exceeds those recommended by ROHM
  - [c] the Products are exposed to direct sunshine or condensation
  - [d] the Products are exposed to high Electrostatic
2. Even under ROHM recommended storage condition, solderability of products out of recommended storage time period may be degraded. It is strongly recommended to confirm solderability before using Products of which storage time is exceeding the recommended storage time period.
3. Store / transport cartons in the correct direction, which is indicated on a carton with a symbol. Otherwise bent leads may occur due to excessive stress applied when dropping of a carton.
4. Use Products within the specified time after opening a humidity barrier bag. Baking is required before using Products of which storage time is exceeding the recommended storage time period.

**Precaution for Product Label**

QR code printed on ROHM Products label is for ROHM's internal use only.

**Precaution for Disposition**

When disposing Products please dispose them properly using an authorized industry waste company.

**Precaution for Foreign Exchange and Foreign Trade act**

Since our Products might fall under controlled goods prescribed by the applicable foreign exchange and foreign trade act, please consult with ROHM representative in case of export.

**Precaution Regarding Intellectual Property Rights**

1. All information and data including but not limited to application example contained in this document is for reference only. ROHM does not warrant that foregoing information or data will not infringe any intellectual property rights or any other rights of any third party regarding such information or data. ROHM shall not be in any way responsible or liable for infringement of any intellectual property rights or other damages arising from use of such information or data.:
2. No license, expressly or implied, is granted hereby under any intellectual property rights or other rights of ROHM or any third parties with respect to the information contained in this document.

**Other Precaution**



1. This document may not be reprinted or reproduced, in whole or in part, without prior written consent of ROHM.
2. The Products may not be disassembled, converted, modified, reproduced or otherwise changed without prior written consent of ROHM.
3. In no event shall you use in any way whatsoever the Products and the related technical information contained in the Products or this document for any military purposes, including but not limited to, the development of mass-destruction weapons.
4. The proper names of companies or products described in this document are trademarks or registered trademarks of ROHM, its affiliated companies or third parties.

**General Precaution**





1. Before you use our Products, you are requested to carefully read this document and fully understand its contents. ROHM shall not be in any way responsible or liable for failure, malfunction or accident arising from the use of any ROHM's Products against warning, caution or note contained in this document.
2. All information contained in this document is current as of the issuing date and subject to change without any prior notice. Before purchasing or using ROHM's Products, please confirm the latest information with a ROHM sales representative.
3. The information contained in this document is provided on an "as is" basis and ROHM does not warrant that all information contained in this document is accurate and/or error-free. ROHM shall not be in any way responsible or liable for any damages, expenses or losses incurred by you or third parties resulting from inaccuracy or errors of or concerning such information.

## Looking for pricing, stock, or lifecycle information?

Click below to explore more details on WIN SOURCE:

-  [View BD34700FV-E2 on WIN SOURCE](#)
-  [Rohm Semiconductor](#) Information

## Optimize Your Supply Chain with WIN SOURCE Solutions

-  Global Sourcing Solution
-  Obsolete Management
-  Cost Control Management
-  Shortage Management
-  Alternative Solution
-  Excess Inventory Management