



**THE DATASHEET OF
SP2209EEY-L**



General Description

The rugged, high ESD **SP2209E** device is a complete dual RS-232 port integrated into a single integrated circuit. Six drivers and ten receivers provide designers a dual port solution fully meeting the EIA / TIA-232 and ITU-T V.28 / V.24 communication protocols, and can be implemented in applications such as personal desktop computers and workstations. Features include high transmission rates, low power consumption, an internal charge-pump power supply that requires only two capacitors, space saving 38-pin TSSOP package dimensions, and compatibility with the EU directive on electromagnetic compatibility. This device is ideal for operation in electrically harsh environments or where RS-232 cables are frequently being plugged and unplugged. This device is also immune to high RF field strengths without special shielding precautions.

Pinout

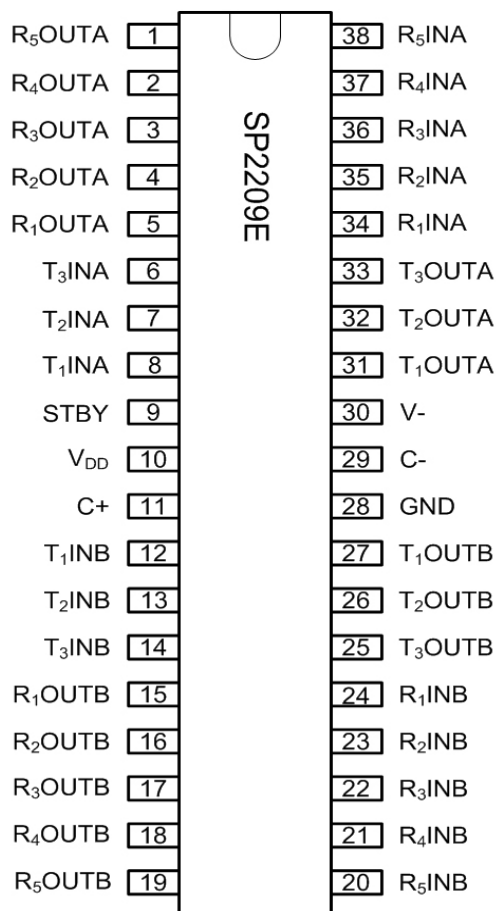

Figure 1: SP2209E Pinout

Features

- Meets true EIA/TIA-232-F standards
- Complies with 89 / 336 / EEC EMC Directive
- Single +12V power supply
- <5mA low power CMOS operation
- 100µA low standby current
- Operates with +3V or +5V logic
- Provides +3.3V to +5V standby supply
- Two complete serial ports, 6 drivers and 10 receivers
- One receiver on each port active in standby
- Failsafe receiver outputs
- 460kbps minimum data rate
- Ideal for high speed RS-232 applications
- Low EMI emissions (EN55022)
- Pin compatible to ADM2209E device
- Enhanced ESD specifications:
 - +15kV Human Body Model
 - +15kV IEC61000-4-2 Air Discharge
 - +8kV IEC61000-4-2 Contact Discharge
- Fast transient burst (EFT) immunity (IEC61000-4-4)

Ordering Information - [page 15](#)

Revision History

Revision	Release Date	Change Description
--	2006	Legacy Sipex Datasheet
1.0.0	7/16/12	Convert to Exar Format and update ordering information. Change ESD specifications to IEC61000-4-2.
1.0.1	6/28/19	Convert to MaxLinear format. Added ESD Rating table under Absolute Maximums. Update Ordering Information. Update power dissipation.

Table of Contents

General Description	i
Pinout	i
Features	i
Specifications	1
Absolute Maximum Ratings.....	1
ESD Ratings.....	1
Electrical Characteristics	2
Pin Information	4
Pin Configuration	4
Pin Descriptions	5
Typical Operating Circuits	6
Description	7
Theory of Operation	7
Drivers	7
Receivers	8
Charge Pump	9
Standby Circuitry	9
ESD Tolerance	10
Applications	12
LapLink Compatibility	12
Mechanical Dimensions	14
Ordering Information	15

List of Figures

Figure 1: SP2209E Pinout	i
Figure 2: SP2209E Pinout (Top View).....	4
Figure 3: SP2209E Typical Operating Circuits	6
Figure 4: Driver Propagation Delay and Transition Time Test Circuit	7
Figure 5: Driver Propagation Delay	8
Figure 6: Receiver Propagation Delay and Transition Time Test Circuit.....	8
Figure 7: Receiver Propagation Delay.....	8
Figure 8: Charge Pump Circuit	9
Figure 9: Charge Pump Waveforms	9
Figure 10: Internal Standby Detection Circuit.....	9
Figure 11: ESD Test Circuit for Human Body Model	11
Figure 12: ESD Test Circuit for IEC61000-4-2	11
Figure 13: ESD Test Waveform for IEC61000-4-2	11
Figure 14: Dual Serial Port Application with Two DB-9 Connectors	13
Figure 15: Mechanical Dimensions, TSSOP38	14

List of Tables

Table 1: Absolute Maximum Ratings	1
Table 2: ESD Ratings	1
Table 3: Electrical Characteristics	2
Table 4: Pin Descriptions.....	5
Table 5: Transceiver ESD Tolerance Levels	10
Table 6: Ordering Information.....	15

Specifications

Absolute Maximum Ratings

Important: These are stress ratings only and functional operation of the device at these ratings or any other above those indicated in the operation sections of the specifications below is not implied. Exposure to absolute maximum rating conditions for extended periods of time may affect reliability and cause permanent damage to the device.

Table 1: Absolute Maximum Ratings

Parameter	Minimum	Maximum	Units
V_{DD}	-0.3V	14.0	V
V_{STBY}	-0.3V	7.0	V
Input Voltages			
TxINA	-0.3	$V_{STBY} + 0.3$	V
TxINB	-0.3	$V_{STBY} + 0.3$	V
RxINA	-15	15	V
RxINB	-15	15	V
Output Voltages			
TxOUTA	-15	15	V
TxOUTB	-15	15	V
RxOUTA	-0.3	$V_{STBY} + 0.3$	V
RxOUTB	-0.3	$V_{STBY} + 0.3$	V
Short-Circuit Duration			
TxOUTA	Continuous		
TxOUTB	Continuous		
Temperature			
Storage temperature	-65	150	°C
Power Dissipation			
38-pin TSSOP (derate 14.3mW/°C above 70°C)		1200	mW

ESD Ratings

Table 2: ESD Ratings

Parameter	Level	Value	Units
HBM — Human Body Model (driver output and receiver inputs)		±15	kV
IEC61000-4-2 Air Discharge (driver output and receiver inputs)	4	±15	kV
IEC61000-4-2 Contact Discharge (driver output and receiver inputs)	4	±8	kV

Electrical Characteristics

Unless otherwise noted, the following specifications apply for $V_{DD} = +12V \pm 10\%$, $V_{STBY} = +3.3V \pm 5\%$ or $+5V \pm 10\%$, $C1 = C2 = 0.1\mu F$, and $T_{AMB} = T_{MIN}$ to T_{MAX} .

Table 3: Electrical Characteristics

Parameter	Test Condition	Minimum	Typical	Maximum	Units
DC Characteristics					
Supply current	No load, all driver inputs at 0.4V or 2.1V, all receiver inputs at +15V or -15V.			5	mA
Standby supply current, V_{STBY}	No load, all driver inputs at V_{STBY} or open		100	200	μA
CMOS Logic Inputs and Receiver Outputs					
Input logic threshold LOW	$T_{AMB} = 25^{\circ}C$			0.4	V
Input logic threshold HIGH	$T_{AMB} = 25^{\circ}C$	2.1			V
Input leakage current	Driver input at 0V		10	25	μA
Output voltage LOW	$I_{OL} = +1.6mA$		0.2	0.4	V
Output voltage HIGH	$I_{OH} = -40\mu A$	2.4			V
Output leakage current	$V_{DD} = 0V$, (except R_5OUTA and R_5OUTB)		± 0.05	± 5	μA
Driver Outputs					
Output voltage swing	All driver outputs loaded with $3k\Omega$ to GND	± 5.0	± 9.0		V
Output resistance	$V_{DD} = V_{STBY} = 0V$, $V_{OUT} = \pm 2V$	300			Ω
Output short-circuit current	One driver output shorted, $V_{IN} = 0.8V$, $V_{OUT} = 0V$	± 5	± 15	± 30	mA
Receiver Inputs					
Input voltage range		-15		15	V
Input threshold LOW		0.4	1.45		V
Input threshold HIGH			1.7	2.4	V
Input hysteresis			0.25		V
Input resistance	$V_{IN} = \pm 15V$	3	5	7	$k\Omega$
Timing Characteristics					
Driver maximum data rate	$R_L = 3k\Omega$ to $7k\Omega$, $C_L = 50pF$ to $470pF$	460			kbps
Driver maximum data rate	$R_L = 3k\Omega$ to $7k\Omega$, $C_L = 50pF$ to $1000pF$, $T_{AMB} = 0^{\circ}C$ to $+85^{\circ}C$, $V_{STBY} = 5V \pm 10\%$ only	460			kbps
Driver maximum data rate	$R_L = 3k\Omega$ to $7k\Omega$, $C_L = 50pF$ to $470pF$, $V_{STBY} = 5V \pm 5\%$ only, $V_{DD} = 12V \pm 5\%$	920			kbps
Driver propagation delay, t_{PHL}	$R_L = 3k\Omega$, $C_L = 1000pF$, see Figure 4 and Figure 5		1.0		μs
Driver propagation delay, t_{PLH}	$R_L = 3k\Omega$, $C_L = 1000pF$, see Figure 4 and Figure 5		1.0		μs
Driver transition-region slew rate	$R_L = 3k\Omega$ to $7k\Omega$, $C_L = 50pF$ to $470pF$, measurements taken from $-3.0V$ to $+3.0V$ or $+3.0V$ to $-3.0V$	6	16		V/ μs
Driver transition-region slew rate	$R_L = 3k\Omega$ to $7k\Omega$, $C_L = 50pF$ to $1000pF$, $V_{STBY} = 5V \pm 10\%$ only, measurements taken from $-3.0V$ to $+3.0V$ or $+3.0V$ to $-3.0V$	4	16		V/ μs
Receiver maximum data rate	$C_L = 150pF$	460			kbps
Receiver maximum data rate	$C_L = 150pF$, $V_{STBY} = 5V \pm 5\%$ only	920			kbps

Table 3: (Continued) Electrical Characteristics

Parameter	Test Condition	Minimum	Typical	Maximum	Units
Receiver propagation delay, t_{PHL} (R1x - R4x)	$C_L = 150\text{pF}$, see Figure 6 and Figure 7		0.4	0.75	μs
Receiver propagation delay, t_{PLH} (R1x - R4x)	$C_L = 150\text{pF}$, see Figure 6 and Figure 7		0.4	0.75	μs
Receiver propagation delay, t_{PHL} (R5x)	$C_L = 150\text{pF}$, see Figure 6 and Figure 7		1.0	2.0	μs
Receiver propagation delay, t_{PLH} (R5x)	$C_L = 150\text{pF}$, see Figure 6 and Figure 7		1.0	2.0	μs
Receiver output rise time	See Figure 6 and Figure 7		30		ns
Receiver output fall time	See Figure 6 and Figure 7		30		ns
Operating Characteristics					
Operating voltage range, V_{DD}		+10.8	+12.0	+13.2	V
Standby voltage range, V_{STBY}		+3.15		+5.5	V
Operating temperature, T_{AMB}		-40		+85	$^{\circ}\text{C}$

Pin Information

Pin Configuration

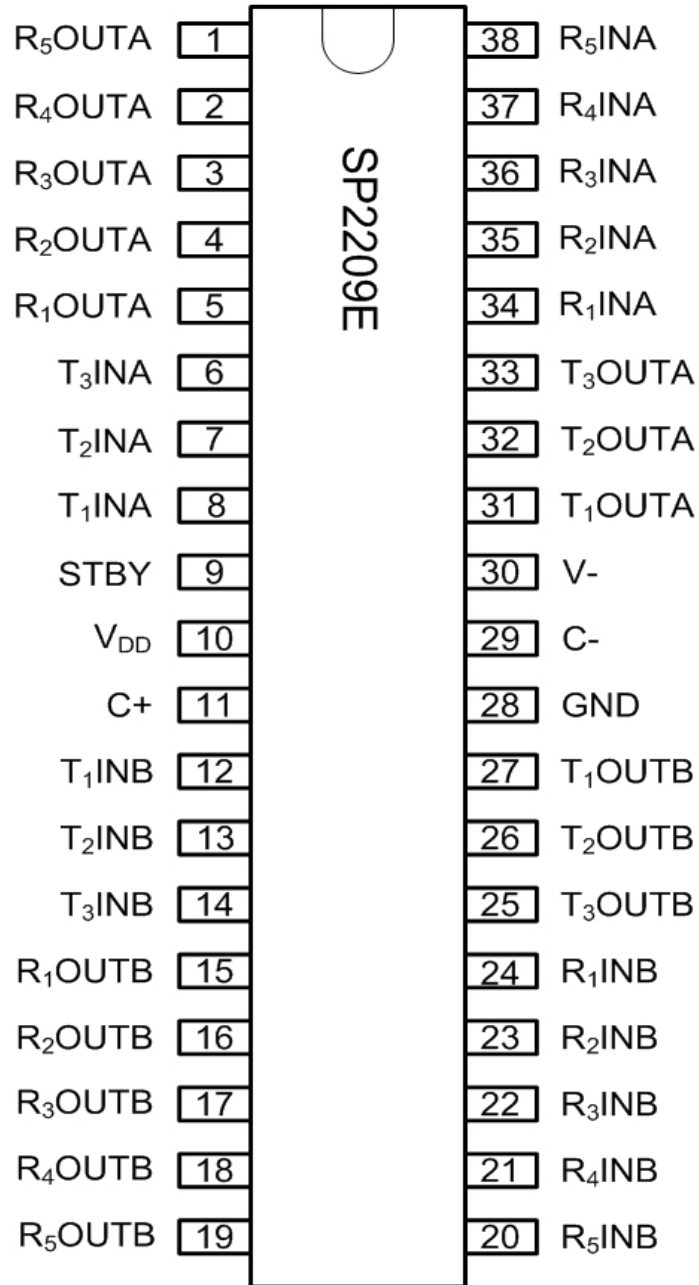

Figure 2: SP2209E Pinout (Top View)

Pin Descriptions

Table 4: Pin Descriptions

Pin Number	Pin Name	Description
1	R ₅ OUTA	+3.3V to +5V TTL / CMOS logic level receiver output for port A
2	R ₄ OUTA	+3.3V to +5V TTL / CMOS logic level receiver output for port A
3	R ₃ OUTA	+3.3V to +5V TTL / CMOS logic level receiver output for port A
4	R ₂ OUTA	+3.3V to +5V TTL / CMOS logic level receiver output for port A
5	R ₁ OUTA	+3.3V to +5V TTL / CMOS logic level receiver output for port A
6	T ₃ INA	+3.3V to +5V TTL / CMOS logic level driver input for port A
7	T ₂ INA	+3.3V to +5V TTL / CMOS logic level driver input for port A
8	T ₁ INA	+3.3V to +5V TTL / CMOS logic level driver input for port A
9	STBY	+3.3V to +5V standby power supply for receivers R ₅ OUTA and R ₅ OUTB
10	V _{DD}	+12V power supply
11	C+	Positive terminal for the polarized C1 charge pump capacitor
12	T ₁ INB	+3.3V to +5V TTL / CMOS logic level driver input for port B
13	T ₂ INB	+3.3V to +5V TTL / CMOS logic level driver input for port B
14	T ₃ INB	+3.3V to +5V TTL / CMOS logic level driver input for port B
15	R ₁ OUTB	+3.3V to +5V TTL / CMOS logic level receiver output for port B
16	R ₂ OUTB	+3.3V to +5V TTL / CMOS logic level receiver output for port B
17	R ₃ OUTB	+3.3V to +5V TTL / CMOS logic level receiver output for port B
18	R ₄ OUTB	+3.3V to +5V TTL / CMOS logic level receiver output for port B
19	R ₅ OUTB	+3.3V to +5V TTL / CMOS logic level receiver output for port B
20	R ₅ INB	RS-232 receiver input for port B
21	R ₄ INB	RS-232 receiver input for port B
22	R ₃ INB	RS-232 receiver input for port B
23	R ₂ INB	RS-232 receiver input for port B
24	R ₁ INB	RS-232 receiver input for port B
25	T ₁ OUTB	RS-232 driver output for port B
26	T ₂ OUTB	RS-232 driver output for port B
27	T ₃ OUTB	RS-232 driver output for port B
28	GND	Ground
29	C-	Negative terminal for the polarized C1 charge pump capacitor
30	V-	-12V output generated by the charge pump at the negative terminal of the polarized C2 charge pump capacitor
31	T ₁ OUTA	RS-232 driver output for port A
32	T ₂ OUTA	RS-232 driver output for port A
33	T ₃ OUTA	RS-232 driver output for port A
34	R ₁ INA	RS-232 receiver input for port A
35	R ₂ INA	RS-232 receiver input for port A
36	R ₃ INA	RS-232 receiver input for port A
37	R ₄ INA	RS-232 receiver input for port A
38	R ₅ INA	RS-232 receiver input for port A

Typical Operating Circuits

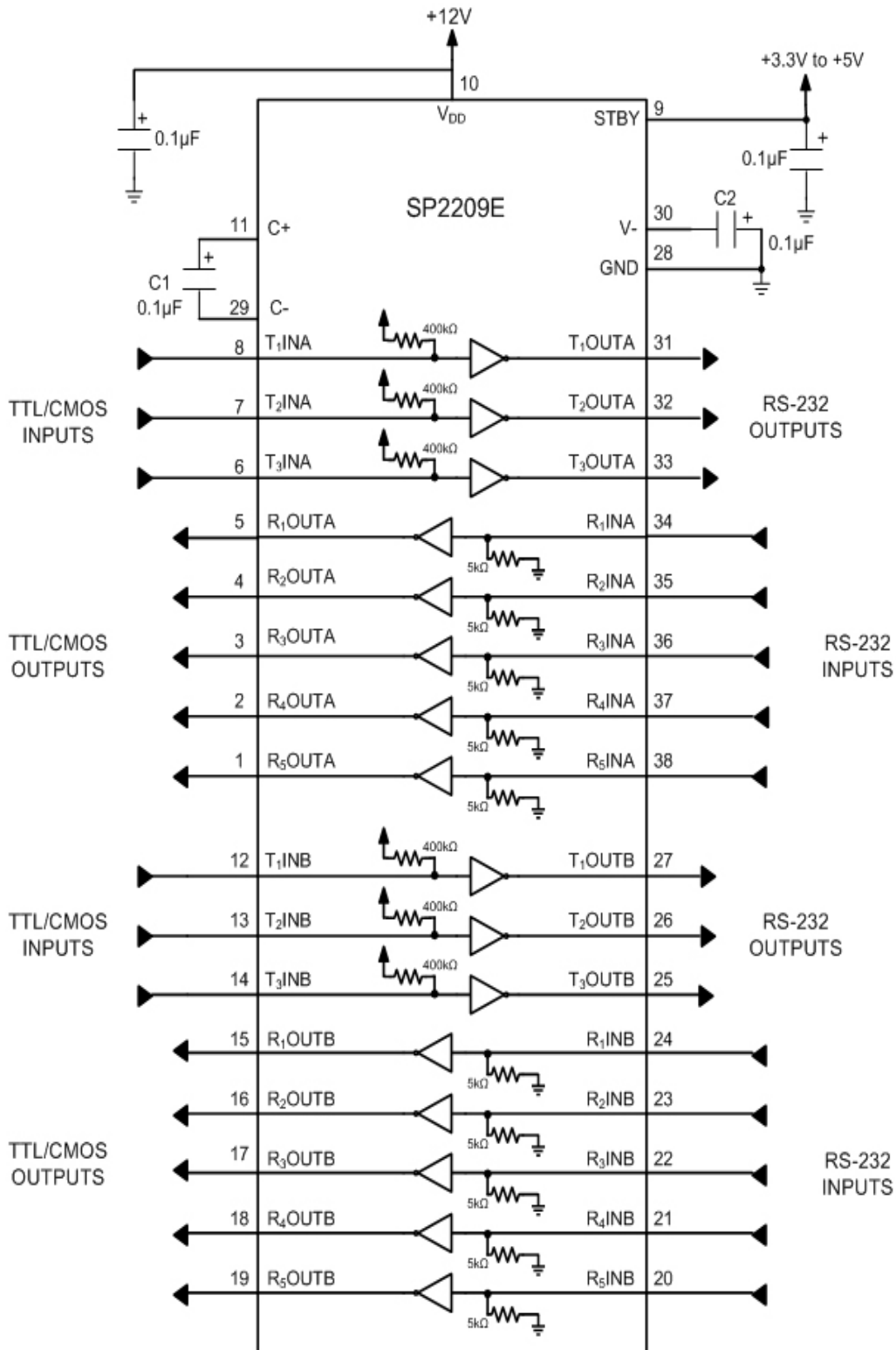

Figure 3: SP2209E Typical Operating Circuits

Description

The SP2209E device is a rugged, high ESD, complete dual RS-232 port integrated onto a single integrated circuit. Six drivers and ten receivers provide a dual port solution fully meeting the EIA / TIA-232 and ITU-T V.28 / V.24 communication protocols and can be implemented in applications such as personal desktop computers and workstations. Refer to [Figure 3](#) for a typical operating circuit.

Features include high transmission rates, low power consumption, space saving package dimensions, and compatibility with the EU directive on electromagnetic compatibility. EM compatibility includes protection against radiated and conducted interference, including high levels of electrostatic discharge. The SP2209E is ideal for operation in electrically harsh environments or where RS-232 cables are frequently being plugged and unplugged. This device is also immune to high RF field strengths without special shielding precautions. Emissions are also controlled to within very strict limits.

The SP2209E features the inverter portion of MaxLinear's proprietary and patented (U.S. 5,306,954) on-board charge pump circuitry that generates a $-9V$ voltage level from a single $+12V$ power supply. It can operate at data rates up to 460kbps fully loaded.

Its low power CMOS operation makes the device an ideal choice for power sensitive designs. The SP2209E has two receivers: one for each RS-232 port that remains active in the standby mode to allow the monitoring of peripheral devices, while the rest of the system is in a power-saving standby mode. This allows the device to wake up the entire system when any communication is initiated in peripheral devices. The SP2209E has a low standby current of 100mA.

Theory of Operation

The SP2209E is made up of four basic circuit blocks:

1. Drivers
2. Receivers
3. The MaxLinear proprietary charge pump
4. Standby circuitry

Drivers

The drivers are inverting level transmitters that convert TTL or CMOS logic levels to EIA / TIA-232 levels with an inverted sense relative to the input logic levels. With $V_{DD} = +12V$, the typical RS-232 output voltage swing is $\pm 9V$ with no load, and $\pm 5V$ minimum fully loaded. Each unused driver input may be left unconnected with an internal pull-up resistor that pulls the input high, forcing the driver output into a low state. The driver outputs are protected against infinite short-circuits to ground without degradation in reliability. These drivers comply with EIA / TIA-232F and all other previous versions.

The drivers typically operate at a minimum data rate of 460kbps, fully loaded with $3k\Omega$ in parallel with $1000pF$, ensuring compatibility with PC-to-PC communication software. The SP2209E device is ideal for the new generation modem standards which require data rates greater than 460kbps. Refer to [Figure 4](#) and [Figure 5](#) for the driver propagation delay test circuit and waveforms, respectively.

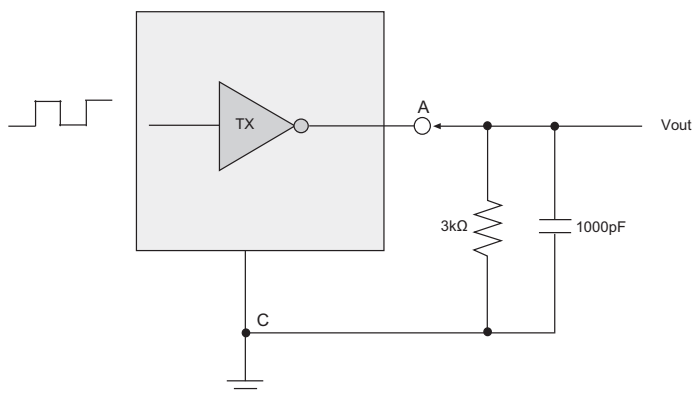

Figure 4: Driver Propagation Delay and Transition Time Test Circuit

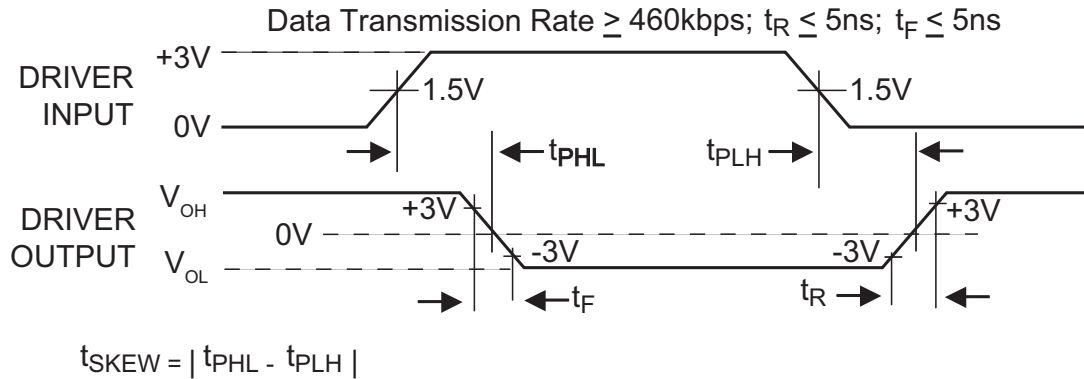

Figure 5: Driver Propagation Delay

Receivers

The receivers convert EIA/TIA-232 levels to TTL or CMOS logic output levels. Should an input be left unconnected, an internal 5kΩ pull-down resistor to ground will commit the output of the receiver to a HIGH state. Receiver inputs are protected against overvoltages of up to ±15V. Refer to [Figure 6](#) and [Figure 7](#) for the receiver propagation delay test circuit and waveforms, respectively.

One receiver in each RS-232 port can be kept active by a low current, +3.3V to +5V power supply while the rest of the channels are powered down. This allows the SP2209E to monitor peripheral devices while the rest of the system is in a power-saving standby mode. The SP2209E can be implemented as a power management device to wake up the entire system when any communication is initiated in peripheral devices. The device has a low standby current of 100μA.

Since receiver input is usually from a transmission line where long cable lengths and system interference can degrade the signal, the inputs have a typical hysteresis

margin of 300mV. This ensures that the receiver is virtually immune to noisy transmission lines and inputs with slow transition times.

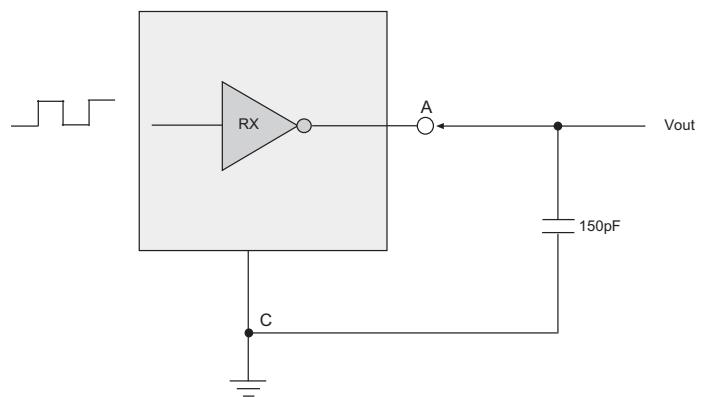

Figure 6: Receiver Propagation Delay and Transition Time Test Circuit

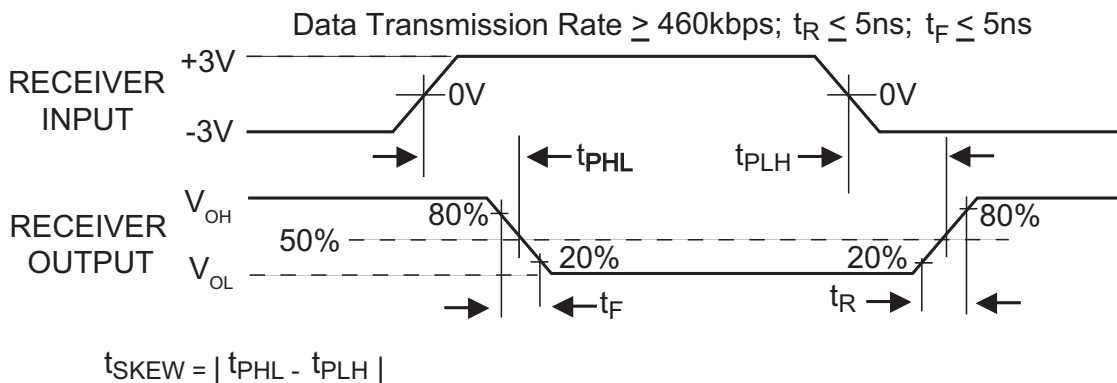

Figure 7: Receiver Propagation Delay

Charge Pump

The charge pump is an MaxLinear-patented design (U.S. 5,306,954) and uses a unique approach compared to older less-efficient designs. The charge pump requires two external capacitors using a two-phase voltage shifting technique with a 200kHz internal oscillator to attain a -9V power supply. Refer to **Figure 8** for the internal charge pump circuit. The internal power supply consists of a charge pump that provides output voltages of at least $\pm 5V$ regardless of the input voltage (V_{DD}). This is important to maintain compliant RS-232 levels, regardless of power supply fluctuations. A description of each phase follows.

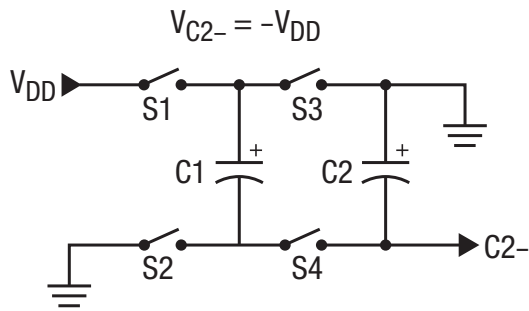

Figure 8: Charge Pump Circuit

Phase 1: V_{DD} Charge Storage

S1 and S2 are closed. S3 and S4 are open. During this phase of the clock cycle, the positive side of C_1 is connected to GND. The negative side of capacitor C_2 is now 2 times V_{CC} .

Phase 2: V_{DD} Transfer

S1 and S2 are closed. S3 and S4 are open. The negative side of capacitor C_2 is connected to C_{2-} , the positive side of C_2 is connected to GND. This transfers a negative generated voltage to C_{2-} . A negative voltage is built up on the negative side of C_2 with each cycle of the oscillator. If the current drawn is small, the output voltage at C_{2-} will be close to $-V_{DD}$. As the current drawn from C_{2-} increases, the output voltage will decrease with magnitude. The charge pump cycle will continue as long as the operational conditions for the internal oscillator are present. Refer to **Figure 9** for the internal charge pump waveforms.

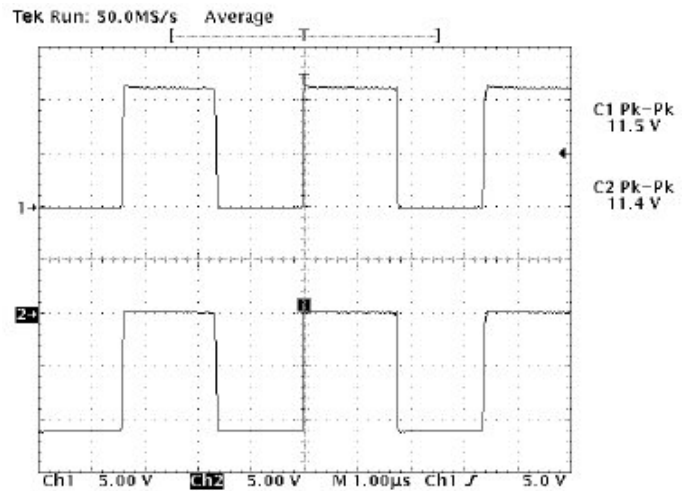

Figure 9: Charge Pump Waveforms

Standby Circuitry

The SP2209E incorporates power saving, on board standby circuitry. The standby current is typically less than $100\mu A$. The device automatically enters a standby mode when the V_{DD} power supply is removed. An internal comparator generates an internal shutdown signal that disables the external oscillator, disengaging the charge pump. Refer to **Figure 10** for the internal standby detection circuit.

The inverted output V^- goes to ground. All driver outputs are disabled. The inputs for receivers 1 through 4 for both ports A and B are at high impedance. Receiver 5 for both ports A and B remain fully active for power management receiver lines to system peripherals that may come on-line during the standby mode.

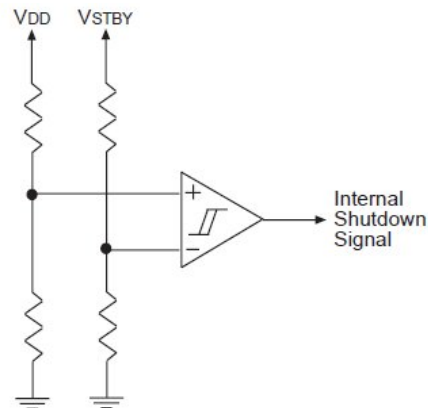

Figure 10: Internal Standby Detection Circuit

ESD Tolerance

The SP2209E device incorporates ruggedized ESD cells on all driver output and receiver input pins. The ESD structure is improved over our previous family for more rugged applications and environments sensitive to electrostatic discharges and associated transients. The improved ESD tolerance is at least $\pm 15\text{kV}$ without damage nor latch-up.

There are different methods of ESD testing applied:

- a. MIL-STD-883, Method 3015.7
- b. IEC 61000-4-2 Air-Discharge
- c. IEC 61000-4-2 Direct Contact

The Human Body Model has been the generally accepted ESD testing method for semiconductors. This method is also specified in MIL-STD-883, Method 3015.7 for ESD testing. The premise of this ESD test is to simulate the human body's potential to store electrostatic energy and discharge it to an integrated circuit. The simulation is performed by using a test model as shown in [Figure 11](#). This method will test the IC's capability to withstand an ESD transient during normal handling such as in manufacturing areas where the IC's tend to be handled frequently.

The IEC-61000-4-2, formerly IEC801-2, is generally used for testing ESD on equipment and systems. System manufacturers must guarantee a certain amount of ESD protection since the system itself is exposed to the outside environment and human presence. The premise with IEC 61000-4-2 is that the system is required to withstand an amount of static electricity when ESD is applied to points and surfaces of the equipment that are accessible to personnel during normal usage. The transceiver IC receives most of the ESD current when the ESD source is applied to the connector pins. The test circuit for IEC 61000-4-2 is shown on [Figure 12](#). There are two methods within IEC 61000-4-2, the Air Discharge Method and the Contact Discharge Method.

With the Air Discharge Method, an ESD voltage is applied to the equipment under test (EUT) through air. This simulates an electrically charged person ready to connect a cable onto the rear of the system only to find an unpleasant zap just before the person touches the back panel. The high energy potential on the person discharges through an arcing path to the rear panel of the system before he or she even touches the system. This energy, whether discharged directly or through air, is predominantly a function of the discharge current rather than the discharge voltage. Variables with an air discharge such as approach speed of

the object carrying the ESD potential to the system and humidity will tend to change the discharge current. For example, the rise time of the discharge current varies with the approach speed.

The Contact Discharge Method applies the ESD current directly to the EUT. This method was devised to reduce the unpredictability of the ESD arc. The discharge current rise time is constant since the energy is directly transferred without the air-gap arc. In situations such as hand held systems, the ESD charge can be directly discharged to the equipment from a person already holding the equipment. The current is transferred on to the keypad or the serial port of the equipment directly and then travels through the PCB and finally to the IC.

The circuit models in [Figure 11](#) and [Figure 12](#) represent the typical ESD testing circuit used for all three methods. The C_S is initially charged with the DC power supply when the first switch (SW1) is on. Now that the capacitor is charged, the second switch (SW2) is on while SW1 switches off. The voltage stored in the capacitor is then applied through the current limiting resistor R_S , onto the device under test (DUT). In ESD tests, SW2 switch is pulsed so that the device under test receives a duration of voltage.

For the Human Body Model, the current limiting resistor (R_S) and the source capacitor (C_S) are $1.5\text{k}\Omega$ and 100pF , respectively. For IEC-61000-4-2, the current limiting resistor (R_S) and the source capacitor (C_S) are 330Ω and 150pF , respectively.

The higher C_S value and lower R_S value in the IEC61000-4-2 model are more stringent than the Human Body Model. The larger storage capacitor injects a higher voltage to the test point when SW2 is switched on. The lower current limiting resistor increases the current charge onto the test point.

Table 5: Transceiver ESD Tolerance Levels

Device Pin Tested	Human Body Model	IEC61000-4-2		
		Air Discharge	Direct Contact	Level
Driver outputs	$\pm 15\text{kV}$	$\pm 15\text{kV}$	$\pm 8\text{kV}$	4
Receiver inputs	$\pm 15\text{kV}$	$\pm 15\text{kV}$	$\pm 8\text{kV}$	4

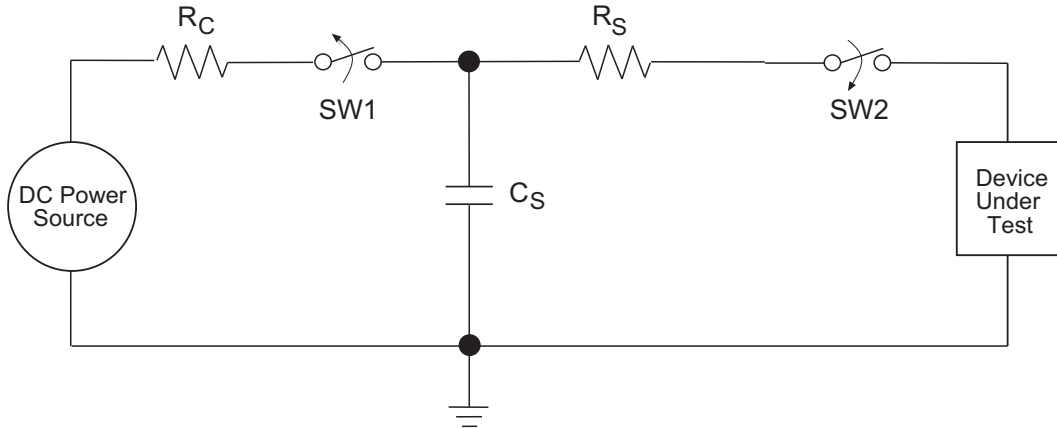

Figure 11: ESD Test Circuit for Human Body Model

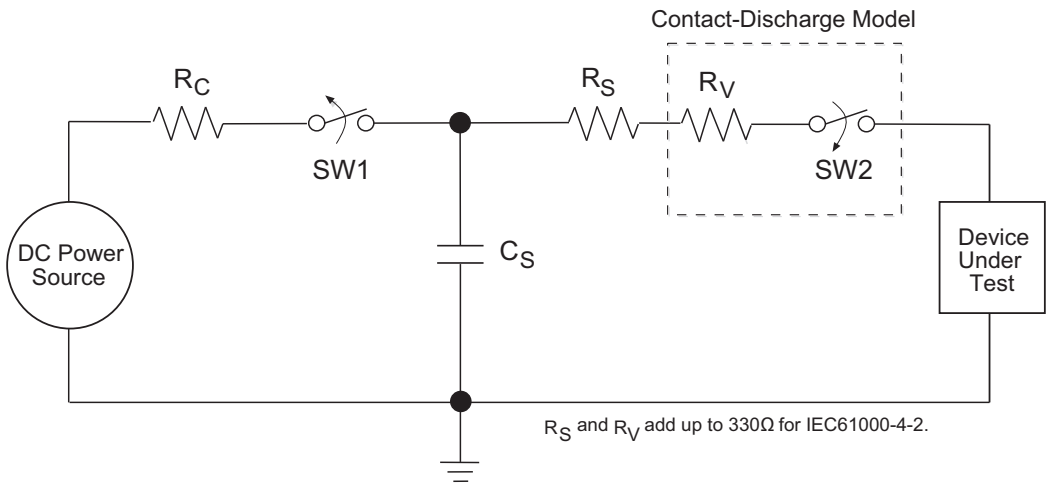

Figure 12: ESD Test Circuit for IEC61000-4-2

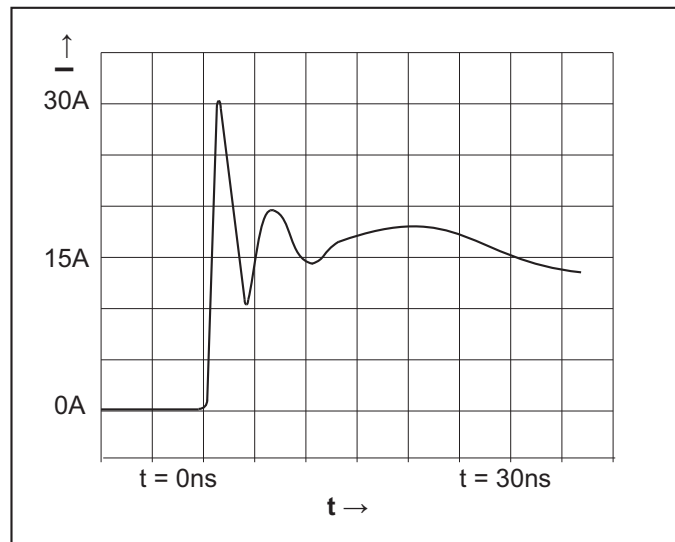

Figure 13: ESD Test Waveform for IEC61000-4-2

Applications

With six drivers and ten receivers, the SP2209E device is ideal for applications requiring two RS-232 ports such as in desktop or portable computers. Refer to [Figure 14](#). For typical DB9 serial ports for Data Terminal Equipment (DTE) to Data Circuit Terminating Equipment (DCE) interface implementation, 2 data lines (TxD and RxD) and 6 control lines (DCD, RTS, DTR, DSR, CTS, and RI) are required. The straight-through pinout for data lines in the SP2209E enables a simplified PCB layout by allowing ground lines to separate the signal lines and ground planes to be placed beneath the IC without the complication of a multi-layer PCB layout.

A receiver from each port, R₅INA and R₅INB, are active while the rest of the channels are powered down. This allows the SP2209E to monitor peripheral devices while the rest of the system is in a power-saving standby mode. Failsafe receiver outputs are pulled high, if the receiver inputs are left unconnected or at zero input. The SP2209E can be implemented as a power management device to wake up the entire system when any communication is initiated in peripheral devices. The SP2209E device has a low standby current of 100µA.

A standard serial mouse can be powered from the SP2209E drivers. Two driver outputs connected in parallel and set to V_{OH} can be used to supply power to the V+ pin of the mouse. The third driver is set to V_{OL} to sink current from the V- terminal. Typical mouse specifications are 10mA at +6V and 5mA at -6V.

LapLink Compatibility

The SP2209E can operate up to 460kbps data under maximum drive load conditions of C_L = 1000pF and R_L = 3kΩ at minimum power supply voltages.

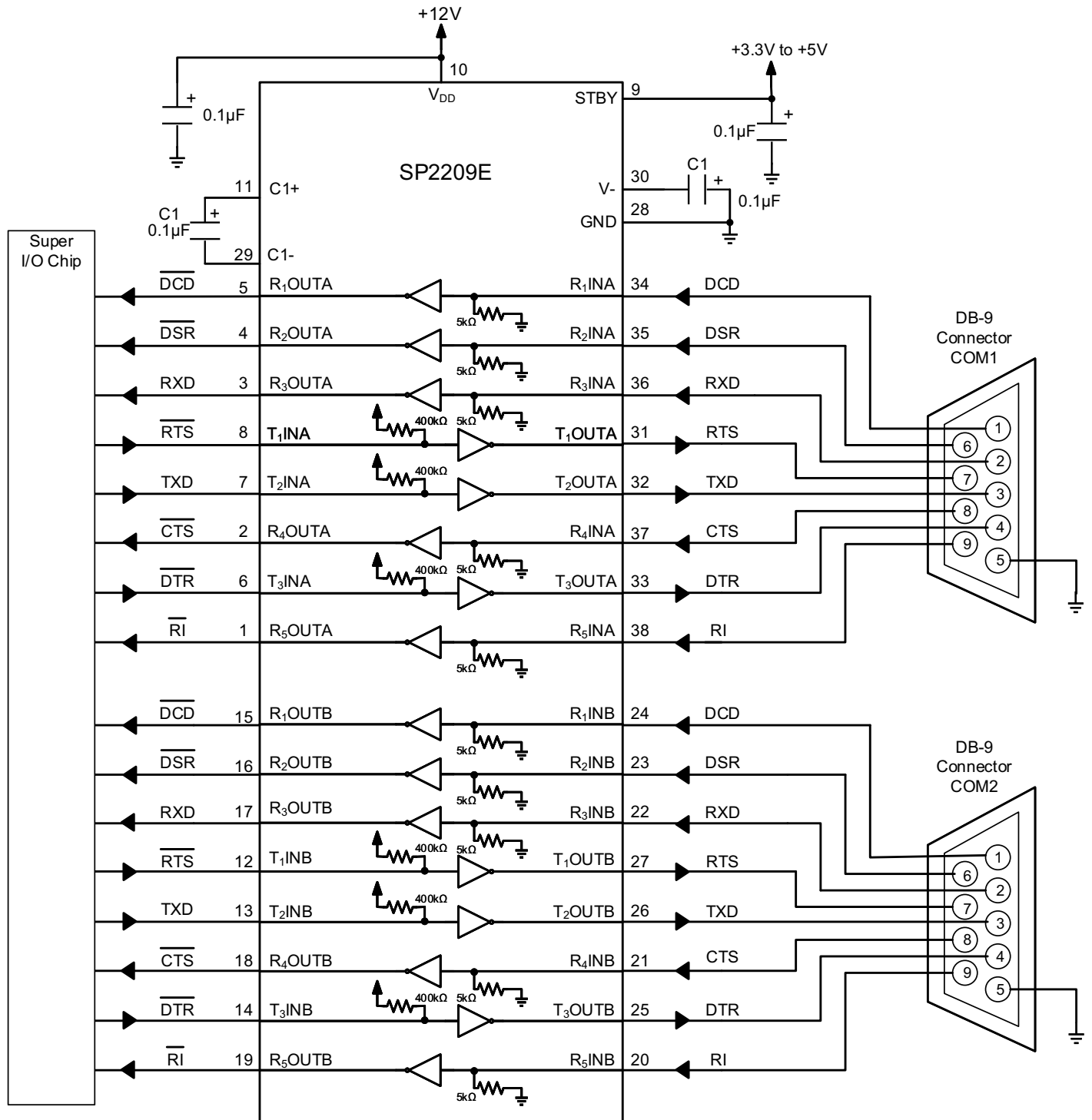
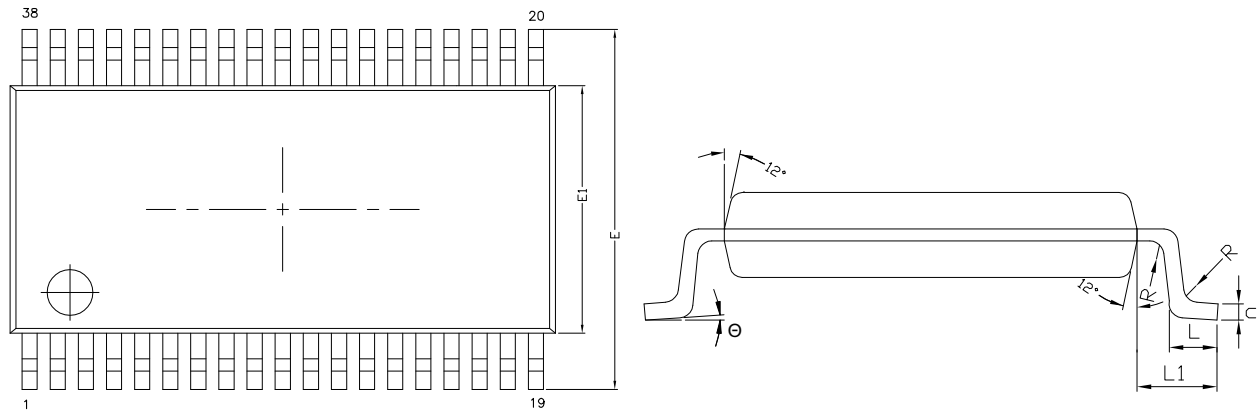

Figure 14: Dual Serial Port Application with Two DB-9 Connectors

Mechanical Dimensions

TSSOP38



TOP VIEW

SIDE VIEW - 1

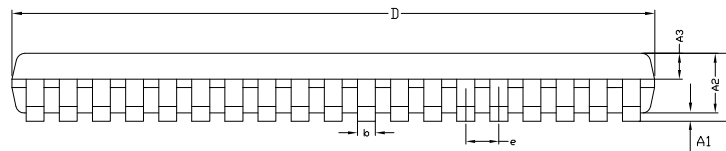

SIDE VIEW - 2

SYMBOL	MIN	NOM	MAX
A	---	---	1.20
A1	0.05	---	0.15
A2	0.80	1.00	1.05
A3	0.34	0.39	0.44
b	0.17	---	0.27
c	0.09	---	0.20
D	9.60	9.70	9.80
E	6.25	6.40	6.55
E1	4.30	4.40	4.5
e	0.50 BSC		
L1	1.00 REF		
L	0.45	0.60	0.75
R	0.09	---	---
θ	0°	---	8°
N	38		

TERMINAL DETAILS

- ALL DIMENSIONS ARE IN MILLIMETERS, ANGLES ARE IN DEGREES.
- DIMENSIONS AND TOLERANCE PER JEDEC MO-153.

Drawing No.: POD-000000 150

Revision: A

Figure 15: Mechanical Dimensions, TSSOP38

Ordering Information

Table 6: Ordering Information⁽¹⁾

Ordering Part Number	Operating Temperature Range	Package	Packaging Method	Lead-Free
SP2209EEY-L/TR	-40°C to 85°C	38-pin TSSOP38	Reel	Yes ⁽²⁾

1. Refer to www.maxlinear.com/SP2209E for most up-to-date Ordering Information.
2. Visit www.maxlinear.com for additional information on Environmental Rating.



MaxLinear, Inc.
5966 La Place Court, Suite 100
Carlsbad, CA 92008
760.692.0711 p.
760.444.8598 f.
www.maxlinear.com

The content of this document is furnished for informational use only, is subject to change without notice, and should not be construed as a commitment by MaxLinear, Inc. MaxLinear, Inc. assumes no responsibility or liability for any errors or inaccuracies that may appear in the informational content contained in this guide. Complying with all applicable copyright laws is the responsibility of the user. Without limiting the rights under copyright, no part of this document may be reproduced into, stored in, or introduced into a retrieval system, or transmitted in any form or by any means (electronic, mechanical, photocopying, recording, or otherwise), or for any purpose, without the express written permission of MaxLinear, Inc.

MaxLinear, Inc. does not recommend the use of any of its products in life support applications where the failure or malfunction of the product can reasonably be expected to cause failure of the life support system or to significantly affect its safety or effectiveness. Products are not authorized for use in such applications unless MaxLinear, Inc. receives, in writing, assurances to its satisfaction that: (a) the risk of injury or damage has been minimized; (b) the user assumes all such risks; (c) potential liability of MaxLinear, Inc. is adequately protected under the circumstances.

MaxLinear, Inc. may have patents, patent applications, trademarks, copyrights, or other intellectual property rights covering subject matter in this document. Except as expressly provided in any written license agreement from MaxLinear, Inc., the furnishing of this document does not give you any license to these patents, trademarks, copyrights, or other intellectual property.

MaxLinear, the MaxLinear logo, and any MaxLinear trademarks, MxL, Full-Spectrum Capture, FSC, G.now, AirPHY and the MaxLinear logo are all on the products sold, are all trademarks of MaxLinear, Inc. or one of MaxLinear's subsidiaries in the U.S.A. and other countries. All rights reserved. Other company trademarks and product names appearing herein are the property of their respective owners.

Looking for pricing, stock, or lifecycle information?

Click below to explore more details on WIN SOURCE:

 [View SP2209EEY-L on WIN SOURCE](#)

 [MaxLinear Inc Information](#)

Optimize Your Supply Chain with WIN SOURCE Solutions

-  Global Sourcing Solution
-  Obsolete Management
-  Cost Control Management
-  Shortage Management
-  Alternative Solution
-  Excess Inventory Management