



**THE DATASHEET OF  
AD8309ARUZ-REEL7**





# 5 MHz–500 MHz 100 dB Demodulating Logarithmic Amplifier with Limiter Output

## AD8309

### FEATURES

**Complete Multistage Log-Limiting IF Amplifier**  
**100 dB Dynamic Range: -78 dBm to +22 dBm (Re 50 Ω)**  
**Stable RSSI Scaling Over Temperature and Supplies:**  
20 mV/dB Slope, -95 dBm Intercept  
±0.4 dB RSSI Linearity up to 200 MHz  
**Programmable Limiter Gain and Output Current**  
**Differential Outputs to 10 mA, 2.4 V p-p**  
**Overall Gain 100 dB, Bandwidth 500 MHz**  
**Constant Phase (Typical ±80 ps Delay Skew)**  
**Single Supply of +2.7 V to +6.5 V at 16 mA Typical**  
**Fully Differential Inputs,  $R_{IN} = 1\text{ k}\Omega$ ,  $C_{IN} = 2.5\text{ pF}$**   
**500 ns Power-Up Time, <1 μA Sleep Current**

### APPLICATIONS

Receivers for Frequency and Phase Modulation  
Very Wide Range IF and RF Power Measurement  
Receiver Signal Strength Indication (RSSI)  
Low Cost Radar and Sonar Signal Processing  
Instrumentation: Network and Spectrum Analyzers

### FUNCTIONAL BLOCK DIAGRAM

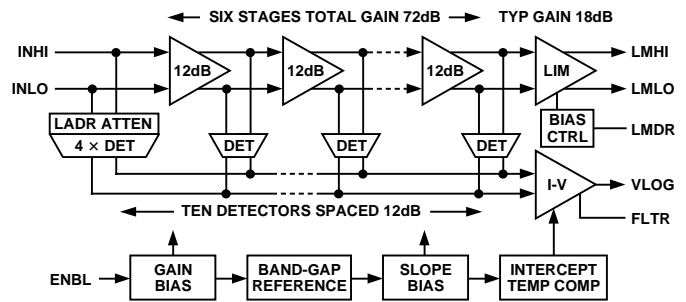

### PRODUCT DESCRIPTION

The AD8309 is a complete IF limiting amplifier, providing both an accurate logarithmic (decibel) measure of the input signal (the RSSI function) over a dynamic range of 100 dB, and a programmable limiter output, useful from 5 MHz to 500 MHz.

It is easy to use, requiring few external components. A single supply voltage of +2.7 V to +6.5 V at 16 mA is needed, corresponding to a power consumption of under 50 mW at 3 V, plus the limiter bias current, determined by the application and typically 2 mA, providing a limiter gain of 100 dB when using 200 Ω loads. A CMOS-compatible control interface can enable the AD8309 within about 500 ns and disable it to a standby current of under 1 μA.

The six cascaded amplifier/limiter cells in the main path have a small signal gain of 12.04 dB (×4), with a -3 dB bandwidth of 850 MHz, providing a total gain of 72 dB. The programmable output stage provides a further 18 dB of gain. The input is fully differential and presents a moderately high impedance (1 kΩ in parallel with 2.5 pF). The input-referred noise-spectral-density, when driven from a terminated 50 Ω, source is  $1.28\text{ nV}/\sqrt{\text{Hz}}$ , equivalent to a noise figure of 3 dB. The sensitivity of the AD8309 can be raised by using an input matching network.

Each of the main gain cells includes a full-wave detector. An additional four detectors, driven by a broadband attenuator, are used to extend the top end of the dynamic range by over 48 dB.

### REV. B

Information furnished by Analog Devices is believed to be accurate and reliable. However, no responsibility is assumed by Analog Devices for its use, nor for any infringements of patents or other rights of third parties which may result from its use. No license is granted by implication or otherwise under any patent or patent rights of Analog Devices.

The overall dynamic range for this combination extends from -91 dBV (-78 dBm at the 50 Ω level) to a maximum permissible value of +9 dBV, using a balanced drive of antiphase inputs each of 2 V in amplitude, which would correspond to a sine wave power of +22 dBm if the differential input were terminated in 50 Ω. The slope of the RSSI output is closely controlled to 20 mV/dB, while the intercept is set to -108 dBV (-95 dBm re 50 Ω). These scaling parameters are determined by a band-gap voltage reference and are substantially independent of temperature and supply. The logarithmic law conformance is typically within ±0.4 dB over the central 80 dB of this range at any frequency between 10 MHz and 200 MHz, and is degraded only slightly at 500 MHz.

The RSSI response time is nominally 67 ns (10%–90%). The averaging time may be increased without limit by the addition of an external capacitor. The full output of 2.34 V at the maximum input of +9 dBV can drive any resistive load down to 50 Ω and this interface remains stable with any value of capacitance on the output.

The AD8309 is fabricated on an advanced complementary bipolar process using silicon-on-insulator isolation techniques and is available in the industrial temperature range of -40°C to +85°C, in a 16-lead TSSOP package.

# AD8309—SPECIFICATIONS ( $V_S = +5\text{ V}$ , $T_A = +25^\circ\text{C}$ , unless otherwise noted)

Parameter	Conditions	Min <sup>1</sup>	Typ	Max <sup>1</sup>	Units
<b>INPUT STAGE</b>					
Maximum Input <sup>2</sup>	(Inputs INHI, INLO) Differential Drive, p-p	$\pm 3.5$	$\pm 4$		V
Equivalent Power in 50 $\Omega$	Terminated in 52.3 $\Omega$		$\pm 9$		dBV
Noise Floor	Terminated 50 $\Omega$ Source		+22		dBm
Equivalent Power in 50 $\Omega$	500 MHz Bandwidth		1.28		$\text{nV}/\sqrt{\text{Hz}}$
Input Resistance	From INHI to INLO	800	1000	1200	$\Omega$
Input Capacitance	From INHI to INLO		2.5		pF
DC Bias Voltage	Either Input		1.725		V
<b>LIMITING AMPLIFIER</b>					
Usable Frequency Range	(Outputs LMHI, LMLO)	5		500	MHz
At Limiter Output	$R_{\text{LOAD}} = R_{\text{LIM}} = 50\ \Omega$ to $-10\ \text{dBm}$ Point		875		MHz
Phase Variation at 100 MHz	Over Input Range $-60\ \text{dBm}$ to $+10\ \text{dBm}$		$\pm 3$		Degrees
Limiter Output Current	Nominally 400 mV/ $R_{\text{LIM}}$ Versus Temperature $-40^\circ\text{C} \leq T_A \leq +85^\circ\text{C}$	0	1	10	mA
Input Range <sup>3</sup>	Equivalent dBm	$-78$		$+9$	dBV
Maximum Output Voltage	At Either LMHI or LMLO, wrt VPS2	$-65$		$+22$	dBm
Rise/Fall Time (10%–90%)	$R_{\text{LOAD}} \leq 50\ \Omega$ , $40\ \Omega \leq R_{\text{LIM}} \leq 400\ \Omega$	1	1.25		V
			0.4		ns
<b>LOGARITHMIC AMPLIFIER</b>					
$\pm 3\ \text{dB}$ Error Dynamic Range	(Output VLOG) From Noise Floor to Maximum Input		100		dB
Transfer Slope	5 MHz $\leq f \leq 200\ \text{MHz}$ Over Temperature $-40^\circ\text{C} < T_A < +85^\circ\text{C}$	18	20	22	mV/dB
Intercept (Log Offset)	5 MHz $\leq f \leq 200\ \text{MHz}$ Equivalent dBm (re 50 $\Omega$ ) Over Temperature $-40^\circ\text{C} \leq T_A \leq +85^\circ\text{C}$ Equivalent dBm (re 50 $\Omega$ ) Temperature Sensitivity	$-116$	$-108$	$-100$	dBV
Linearity Error (Ripple)	Input from $-83\ \text{dBV}$ ( $-70\ \text{dBm}$ ) to $+7\ \text{dBV}$ ( $+20\ \text{dBm}$ )	$-103$	$-95$	$-87$	dBm
Output Voltage	Input = $-91\ \text{dBV}$ ( $-78\ \text{dBm}$ ) $V_S = +5\ \text{V}$ , $+2.7\ \text{V}$ Input = $+9\ \text{dBV}$ ( $+22\ \text{dBm}$ ) $V_S = +5\ \text{V}$ Input = $+9\ \text{dBV}$ ( $+22\ \text{dBm}$ ) $V_S = +2.75\ \text{V}$	$-117$	$-108$	$-99$	dBV
		$-104$	$-95$	$-86$	dBm
			$-0.009$		dB/ $^\circ\text{C}$
Minimum Load Resistance, $R_L$	To Ground	40	50		$\Omega$
Maximum Sink Current		0.75	1.0	1.25	mA
Output Resistance			0.3		$\Omega$
Small-Signal Bandwidth			3.5		MHz
Output Settling Time to 1%	Large Scale Input, $+3\ \text{dBV}$ ( $+16\ \text{dBm}$ ), $R_L \geq 50\ \Omega$ , $C_L \leq 100\ \text{pF}$		120	220	ns
Rise/Fall Time (10%–90%)	Large Scale Input, $+3\ \text{dBV}$ ( $+16\ \text{dBm}$ ), $R_L \geq 50\ \Omega$ , $C_L \leq 100\ \text{pF}$		67	100	ns
<b>POWER INTERFACES</b>					
Supply Voltage, $V_{\text{POS}}$		2.7	5	6.5	V
Quiescent Current	Zero-Signal, LMDR Open	13	16	20	mA
Over Temperature	$-40^\circ\text{C} < T_A < +85^\circ\text{C}$	11	16	23	mA
Disable Current	$-40^\circ\text{C} < T_A < +85^\circ\text{C}$		0.01	4	$\mu\text{A}$
Additional Bias for Limiter	$R_{\text{LIM}} = 400\ \Omega$ (See Text)		1.4	1.6	mA
Logic Level to Enable Power	HI Condition, $-40^\circ\text{C} < T_A < +85^\circ\text{C}$	1.8		$V_{\text{POS}}$	V
Input Current when HI	3 V at ENBL, $-40^\circ\text{C} < T_A < +85^\circ\text{C}$		40	60	$\mu\text{A}$
Logic Level to Disable Power	LO Condition, $-40^\circ\text{C} < T_A < +85^\circ\text{C}$	$-0.5$		1	V

## NOTES

<sup>1</sup>Minimum and maximum specified limits on parameters that are guaranteed but not tested are six sigma values.

<sup>2</sup>The input level is specified in “dBV” since logarithmic amplifiers respond strictly to voltage, not power. 0 dBV corresponds to a sinusoidal single-frequency input of 1 V rms. A power level of 0 dBm (1 mW) in a 50  $\Omega$  termination corresponds to an input of 0.2236 V rms. Hence, the relationship between dBV and dBm is a fixed offset of +13 dBm in the special case of a 50  $\Omega$  termination.

<sup>3</sup>Due to the extremely high Gain Bandwidth Product of the AD8309, the output of either LMHI or LMLO will be unstable for levels below  $-78\ \text{dBV}$  ( $-65\ \text{dBm}$ , re 50  $\Omega$ ).

Specifications subject to change without notice.

### ABSOLUTE MAXIMUM RATINGS\*

Supply Voltage $V_S$ .....	7.5 V
Input Level, Differential (re 50 $\Omega$ ) .....	+26 dBm
Input Level, Single-Ended (re 50 $\Omega$ ) .....	+20 dBm
Internal Power Dissipation .....	500 mW
$\theta_{JA}$ .....	150°C/W
$\theta_{JC}$ .....	27.6°C/W
Maximum Junction Temperature .....	+125°C

Operating Temperature Range .....	-40°C to +85°C
Storage Temperature Range .....	-65°C to +150°C
Lead Temperature Range (Soldering 60 sec) .....	+300°C

\*Stresses above those listed under Absolute Maximum Ratings may cause permanent damage to the device. This is a stress rating only; functional operation of the device at these or any other conditions above those indicated in the operational section of this specification is not implied. Exposure to absolute maximum rating conditions for extended periods may effect device reliability.

### ORDERING GUIDE

Model	Temperature Range	Package Description	Package Option
AD8309ARU	-40°C to +85°C	16-Lead TSSOP	RU-16
AD8309ARU-REEL	-40°C to +85°C	13" Tape and Reel	RU-16
AD8309ARU-REEL7	-40°C to +85°C	7" Tape and Reel	RU-16
AD8309-EVAL		Evaluation Board	

### CAUTION

ESD (electrostatic discharge) sensitive device. Electrostatic charges as high as 4000 V readily accumulate on the human body and test equipment and can discharge without detection. Although the AD8309 features proprietary ESD protection circuitry, permanent damage may occur on devices subjected to high energy electrostatic discharges. Therefore, proper ESD precautions are recommended to avoid performance degradation or loss of functionality.



### PIN FUNCTION DESCRIPTIONS

Pin	Name	Function
1	COM2	Special Common Pin for RSSI Output.
2	VPS1	Supply Pin for First Five Amplifier Stages and the Main Biasing System.
3, 6, 11, 14	PADL	Four Tie-Downs to the Paddle on Which the IC Is Mounted; Grounded.
4	INHI	Signal Input, HI or Plus Polarity.
5	INLO	Signal Input, LO or Minus Polarity.
7	COM1	Main Common Connection.
8	ENBL	Chip Enable; Active When HI.
9	LMDR	Limiter Drive Programming Pin.
10	FLTR	RSSI Bandwidth-Reduction Pin.
12	LMLO	Limiter Output, LO or Minus Polarity.
13	LMHI	Limiter Output, HI or Plus Polarity.
15	VPS2	Supply Pin for Sixth Gain Stage, Limiter and RSSI Output Stage Load Current.
16	VLOG	Logarithmic (RSSI) Output.

### PIN CONFIGURATION

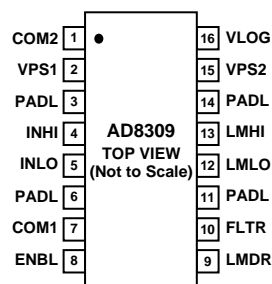

# AD8309—Typical Performance Characteristics

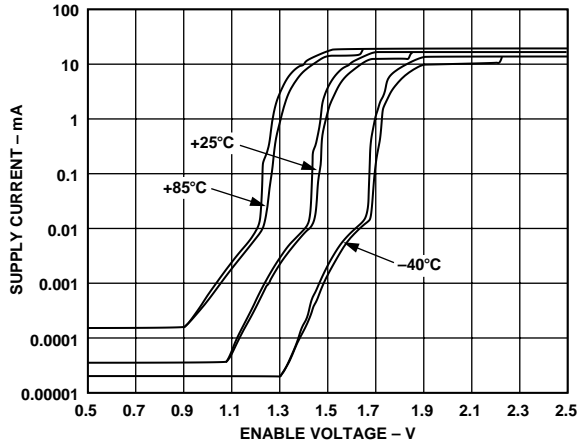

Figure 1. Supply Current vs. Enable Voltage @  $T_A = -40^\circ\text{C}$ ,  $+25^\circ\text{C}$  and  $+85^\circ\text{C}$

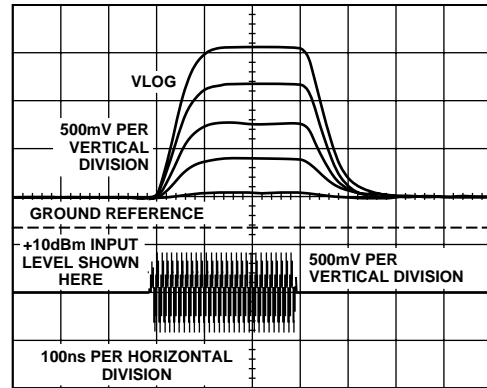

Figure 4. RSSI Pulse Response for Inputs Stepped from Zero to  $-63\text{ dBV}$ ,  $-43\text{ dBV}$ ,  $-23\text{ dBV}$ ,  $-3\text{ dBV}$

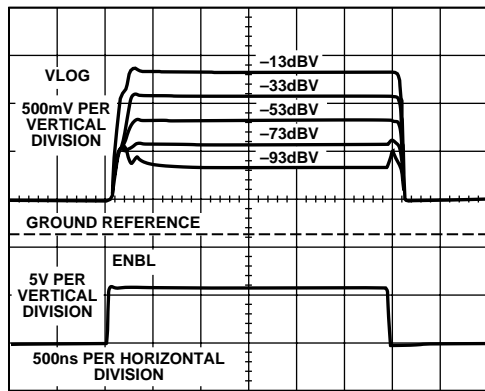

Figure 2. Power On/Off Response Time with RF Input of  $-93\text{ dBV}$  to  $-13\text{ dBV}$

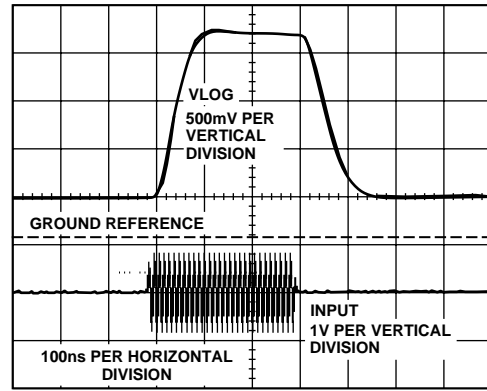

Figure 5. Large Signal RSSI Pulse Response with  $R_L = 100\ \Omega$  and  $C_L = 33\text{ pF}$ ,  $100\text{ pF}$  and  $330\text{ pF}$  (Curves Overlap)

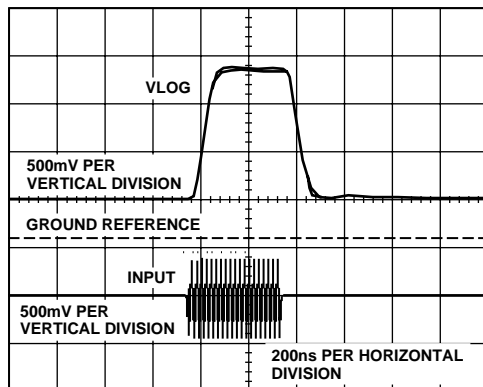

Figure 3. Large Signal RSSI Pulse Response with  $C_L = 100\text{ pF}$  and  $R_L = 50\ \Omega$  and  $75\ \Omega$  (Curves Overlap)

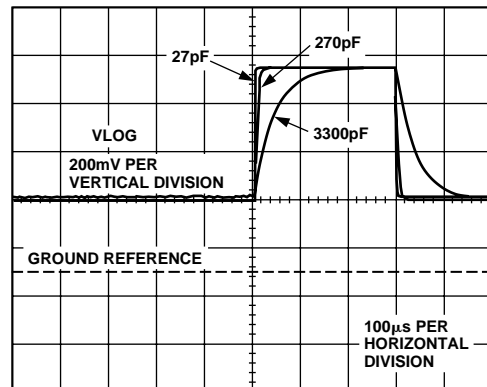

Figure 6. Small Signal AC Response of RSSI Output with External Filter Capacitance of  $27\text{ pF}$ ,  $270\text{ pF}$  and  $3300\text{ pF}$

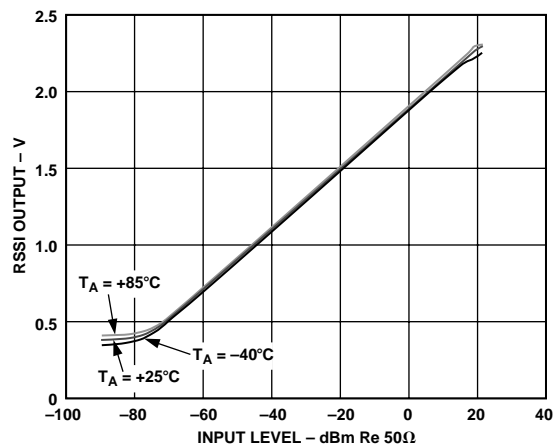

Figure 7. RSSI Output vs. Input Level, 100 MHz Sine Input, at  $T_A = -40^\circ\text{C}$ ,  $+25^\circ\text{C}$  and  $+85^\circ\text{C}$ , Single-Ended Input

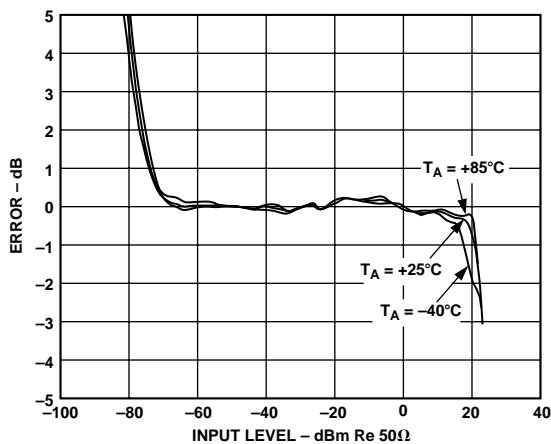

Figure 10. Log Linearity of RSSI Output vs. Input Level, 100 MHz Sine Input, at  $T_A = -40^\circ\text{C}$ ,  $+25^\circ\text{C}$ , and  $+85^\circ\text{C}$

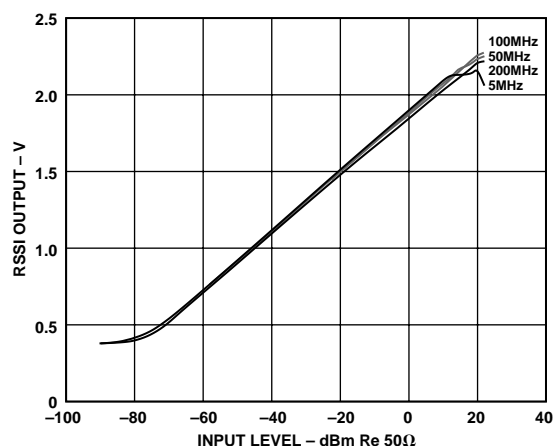

Figure 8. RSSI Output vs. Input Level, at  $T_A = +25^\circ\text{C}$ , for Frequencies of 5 MHz, 50 MHz, 100 MHz and 200 MHz

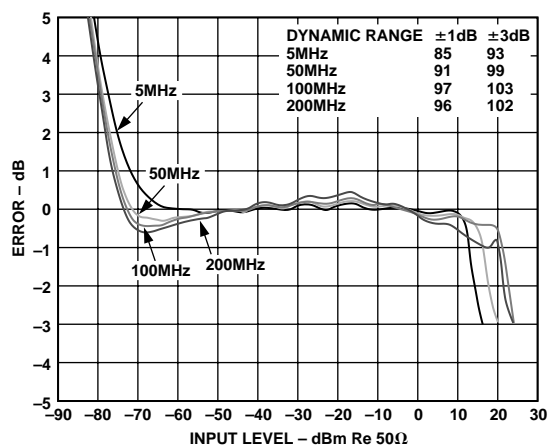

Figure 11. Log Linearity of RSSI Output vs. Input Level, at  $T_A = +25^\circ\text{C}$ , for Frequencies of 5 MHz, 50 MHz, 100 MHz and 200 MHz

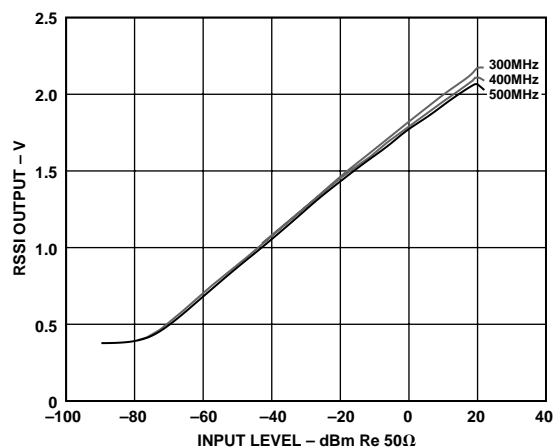

Figure 9. RSSI Output vs. Input Level, at  $T_A = +25^\circ\text{C}$ , for Frequencies of 300 MHz, 400 MHz and 500 MHz

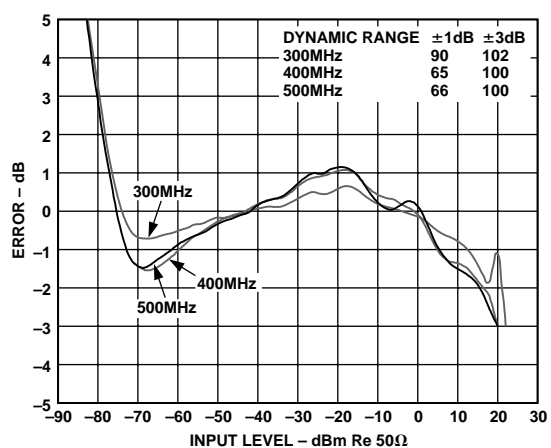

Figure 12. Log Linearity of RSSI Output vs. Input Level, at  $T_A = +25^\circ\text{C}$ , for Frequencies of 300 MHz, 400 MHz and 500 MHz

# AD8309

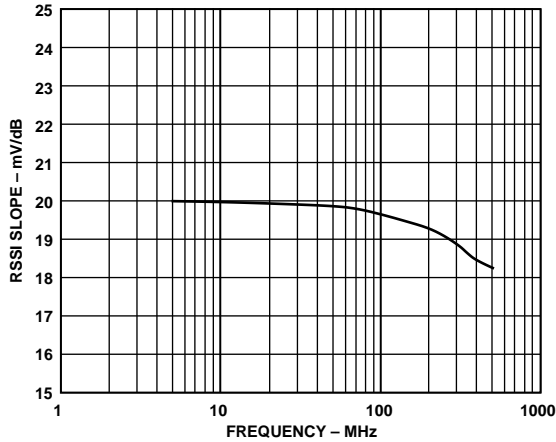

Figure 13. RSSI Slope vs. Frequency Using Termination of 52.3  $\Omega$  in Series with 4.7 nH

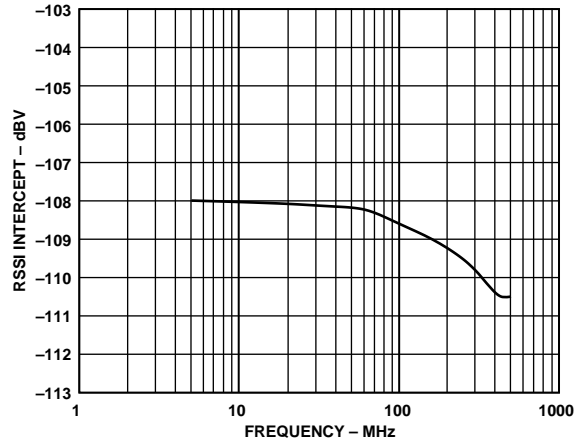

Figure 16. RSSI Intercept vs. Frequency Using Termination of 52.3  $\Omega$  in Series with 4.7 nH

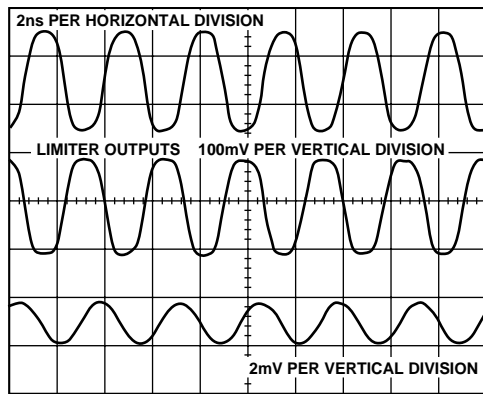

Figure 14. Limiter Output at 300 MHz for a Sine Wave Input of -60 dBV (-47 dBm), Using an  $R_{LOAD}$  of 50  $\Omega$  and an  $R_{LIM}$  of 100  $\Omega$

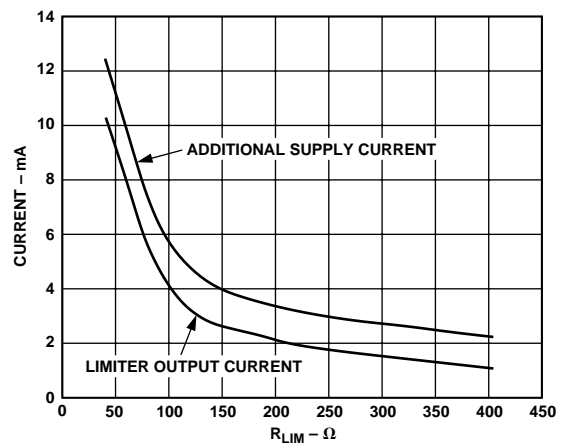

Figure 17. Additional Supply Current and Limiter Output Current vs.  $R_{LIM}$

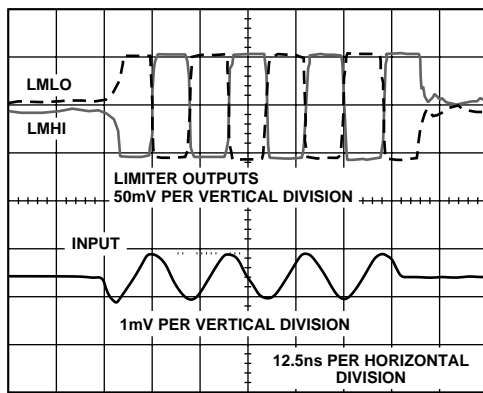

Figure 15. Limiter Response at LMHI, LMLO with Pulsed Sine Input of -70 dBV (-57 dBm) at 50 MHz;  $R_{LOAD} = 50 \Omega$ ,  $R_{LIM} = 200 \Omega$

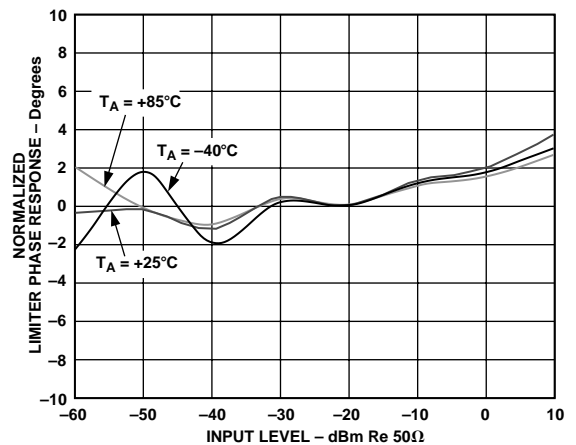

Figure 18. Normalized Limiter Phase Response vs. Input Level. Frequency = 100 MHz;  $T_A = -40^\circ\text{C}$ ,  $+25^\circ\text{C}$  and  $+85^\circ\text{C}$

## THEORY OF OPERATION

The AD8309 is an advanced IF signal processing IC, intended for use in high performance receivers, combining two key functions. First, it provides a large voltage gain combined with progressive compression, through which an IF signal of high dynamic range is converted into a square-wave (that is, hard limited) output, from which frequency and phase information modulated on this input can be recovered by subsequent signal processing. For this purpose, the noise level referred to the input must be very low, since it determines the *detection threshold* for the receiver.

Further, it is often important that the group delay in this amplifier be essentially independent of the signal level, to minimize the risk of amplitude-to-phase conversion. Finally, it is also desirable that the amplitude of the limited output be well defined and temperature stable. In the AD8309, this amplitude can be controlled by the user, or even completely shut off, providing greater flexibility.

The second function is to provide a demodulated (baseband) output proportional to the decibel value of the signal input, which may be used to measure the signal strength. This output, which typically runs from a value close to the ground level to a few volts above ground, is called the *Received Signal Strength Indication*, or RSSI. The provision of this function requires the use of a logarithmic amplifier (log amp). For this output to be suitable for measuring signal strength, it is important that its *scaling attributes* are well controlled.

These are the logarithmic *slope*, specified in mV/dB, and the *intercept*, often specified as an equivalent power level at the amplifier input, although a log amp is inherently a voltage-responding device. (See further discussion, below). Also important is the *law conformance*, that is, how well the RSSI approximates an ideal function. Many low quality log amps provide only an approximate solution, resulting in large errors in law conformance and scaling. All Analog Devices log amps are designed with close attention to matters affecting accuracy of the overall function.

In the AD8309, these two basic signal-processing functions are combined to provide the necessary voltage gain with progressive compression and hard limiting, and the determination of the logarithmic magnitude of the input (RSSI). This combination is called a log limiting amplifier. A good grasp of how this product works will avoid many pitfalls in their application.

### Log-Amp Fundamentals

The essential purpose of a logarithmic amplifier is to reduce a signal of wide dynamic range to its decibel equivalent. It is thus primarily a *measurement device*. The logarithmic representation leads to situations that may be confusing or even paradoxical. For example, a voltage *offset* added to the RSSI output of a log amp is equivalent to a *gain* increase ahead of its input.

When all the variables expressed as voltages, then, regardless of the particular structure, the output can be expressed as

$$V_{OUT} = V_Y \log(V_{IN}/V_X) \quad (1)$$

where  $V_Y$  is the “slope voltage.”  $V_{IN}$  is the input voltage, and  $V_X$  is the “intercept voltage.” The logarithm is usually to base-10, which is appropriate to a decibel-calibrated device, in which case  $V_Y$  is also the “volts-per-decade.” It will be apparent from (1) that a log amp requires two references, here  $V_X$  and  $V_Y$ , that determine the *scaling* of the circuit. The absolute accuracy of a log amp cannot be any better than the accuracy of its *scaling*

references. Note that (1) is mathematically incomplete in representing the behavior of a *demodulating* log amp such as the AD8309, where  $V_{IN}$  has an alternating sign. However, the basic principles are unaffected.

Figure 19 shows the input/output relationship of an ideal log amp, conforming to Equation (1). The horizontal scale is logarithmic, and spans a very wide dynamic range, shown here as over 120 dB, that is, six decades of voltage or twelve decades of input-referred power. The output passes through zero (the “log-intercept”) at the unique value  $V_{IN} = V_X$  and becomes negative for inputs below the intercept. In the ideal case, the straight line describing  $V_{OUT}$  for all values of  $V_{IN}$  would continue indefinitely in both directions. The dotted line shows that the effect of adding an offset voltage  $V_{SHIFT}$  to the output is to lower the effective intercept voltage  $V_X$ .

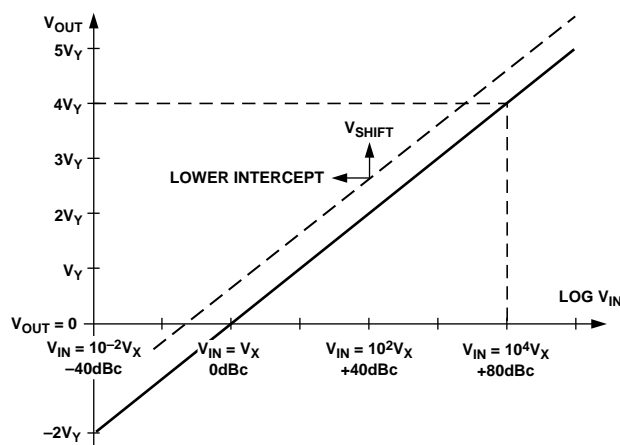

Figure 19. Ideal Log Amp Function

Exactly the same modification could be achieved raising the gain (or signal level) ahead of the log amp by the factor  $V_{SHIFT}/V_Y$ . For example, if  $V_Y$  is 400 mV/decade (that is, 20 mV/dB, as for the AD8309), an offset of 120 mV added to the output will appear to lower the intercept by two tenths of a decade, or 6 dB. Adding an offset to the output is thus indistinguishable from applying an input level that is 6 dB higher.

The log amp function described by (1) differs from that of a linear amplifier in that the incremental gain  $DV_{OUT}/DV_{IN}$  is a very strong function of the instantaneous value of  $V_{IN}$ , as is apparent by calculating the derivative. For the case where the logarithmic base is  $e$ , it is easy to show that

$$\frac{\Delta V_{OUT}}{\Delta V_{IN}} = \frac{V_Y}{V_{IN}} \quad (2)$$

That is, the incremental gain of a log amp is inversely proportional to the instantaneous value of the input voltage. This remains true for any logarithmic base. A “perfect” log amp would be required to have infinite gain under classical “small-signal” (zero-amplitude) conditions. This demonstrates that, whatever means might be used to implement a log amp, accurate HF response under small signal conditions (that is, at the lower end of the full dynamic range) demands the provision of a *very high gain-bandwidth product*. A wideband log amp must therefore use many cascaded gain cells each of low gain but high bandwidth. For the AD8309, the gain-bandwidth (–10 dB) product is 52,500 GHz.

# AD8309

As a consequence of this high gain, even very small amounts of thermal noise at the input of a log amp will cause a finite output for zero input, resulting in the response line curving away from the ideal (Figure 19) at small inputs, toward a fixed baseline. This can either be above or below the intercept, depending on the design. Note that the value specified for this intercept is invariably an *extrapolated* one: the RSSI output voltage will never attain a value of exactly zero in a single supply implementation.

## Voltage (dBV) and Power (dBm) Response

While Equation 1 is fundamentally correct, a simpler formula is appropriate for specifying the RSSI calibration attributes of a log amp like the AD8309, which *demodulates* an RF input. The usual measure is input power:

$$V_{OUT} = V_{SLOPE} (P_{IN} - P_0) \quad (3)$$

$V_{OUT}$  is the demodulated and filtered RSSI output,  $V_{SLOPE}$  is the logarithmic slope, expressed in volts/dB,  $P_{IN}$  is the input power, expressed in decibels relative to some reference power level and  $P_0$  is the logarithmic intercept, expressed in decibels relative to the same reference level.

The most widely used convention in RF systems is to specify power in decibels above 1 mW in 50  $\Omega$ , written dBm. (However, that the quantity  $[P_{IN} - P_0]$  is simply dB). The logarithmic function disappears from this formula because the conversion has already been implicitly performed in stating the input in decibels.

Specification of log amp input level in terms of power is strictly a concession to popular convention: they do *not* respond to *power* (tacitly “power absorbed at the input”), but to the input *voltage*. In this connection, note that the input impedance of the AD8309 is much higher than 50  $\Omega$ , allowing the use of an impedance transformer at the input to raise the sensitivity, by up to 13 dB.

The use of dBV, defined as *decibels with respect to a 1 V rms sine amplitude*, is more precise, although this is still not unambiguous complete as a general metric, because waveform is also involved in the response of a log amp, which, for a complex input (such as a CDMA signal) will not follow the rms value exactly. Since most users specify RF signals in terms of power—more specifically, in dBm/50  $\Omega$ —we use both dBV and dBm in specifying the performance of the AD8309, showing equivalent dBm levels for the special case of a 50  $\Omega$  environment.

## Progressive Compression

High speed, high dynamic range log amps use a cascade of nonlinear amplifier cells (Figure 20) to generate the logarithmic function from a series of contiguous segments, a type of piecewise-linear technique. This basic topology offers enormous gain-bandwidth products. For example, the AD8309 employs in its main signal path six cells each having a small-signal gain of 12.04 dB ( $\times 4$ ) and a  $-3$  dB bandwidth of 850 MHz, followed by a final limiter stage whose gain is typically 18 dB. The overall gain is thus 100,000 (100 dB) and the bandwidth to  $-10$  dB point at the limiter output is 525 MHz. This very high gain-bandwidth product (52,500 GHz) is an essential prerequisite to accurate operation under small signal conditions and at high frequencies: Equation (2) reminds us that the incremental gain decreases rapidly as  $V_{IN}$  increases. The AD8309 exhibits a logarithmic response over most of the range from the noise floor of  $-91$  dBV, or 28  $\mu$ V rms, (or  $-78$  dBm/50  $\Omega$ ) to a breakdown-limited peak input of 4 V (requiring a balanced drive at the differential inputs INHI and INLO).

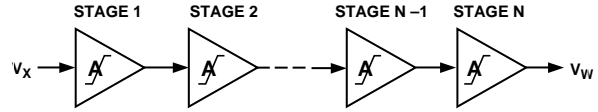

Figure 20. Cascade of Nonlinear Gain Cells

## Theory of Logarithmic Amplifiers

To develop the theory, we will first consider a somewhat different scheme to that employed in the AD8309, but which is simpler to explain, and mathematically more straightforward to analyze. This approach is based on a nonlinear amplifier unit, which we may call an A/1 cell, having the transfer characteristic shown in Figure 21. We here use lowercase variables to define the local inputs and outputs of these cells, reserving uppercase for *external* signals.

The small signal gain  $\Delta V_{OUT}/\Delta V_{IN}$  is A, and is maintained for inputs up to the knee voltage  $E_K$ , above which the *incremental* gain drops to unity. The function is symmetrical: the same drop in gain occurs for instantaneous values of  $V_{IN}$  less than  $-E_K$ . The *large signal* gain has a value of A for inputs in the range  $-E_K < V_{IN} < +E_K$ , but falls asymptotically toward unity for very large inputs.

In logarithmic amplifiers based on this simple function, both the slope voltage and the intercept voltage must be traceable to the one reference voltage,  $E_K$ . Therefore, in this fundamental analysis, the *calibration accuracy* of the log amp is dependent solely on this voltage. In practice, it is possible to separate the basic references used to determine  $V_Y$  and  $V_X$ . In the AD8309,  $V_Y$  is traceable to an on-chip band-gap reference, while  $V_X$  is derived from the thermal voltage  $kT/q$  and later temperature-corrected by a precise means.

Let the input of an N-cell cascade be  $V_{IN}$ , and the final output  $V_{OUT}$ . For small signals, the overall gain is simply  $A^N$ . A six-stage system in which  $A = 5$  (14 dB) has an overall gain of 15,625 (84 dB). The importance of a very high small-signal ac gain in implementing the logarithmic function has already been noted. However, this is a parameter of only incidental interest in the design of log amps; greater emphasis needs to be placed on the *nonlinear* behavior.

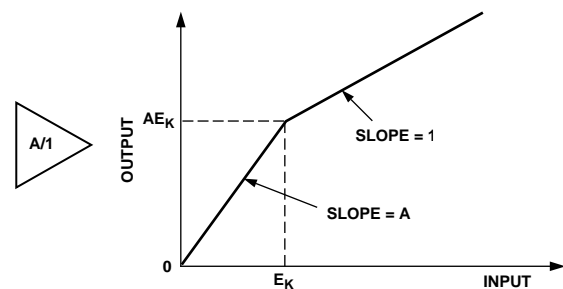

Figure 21. The A/1 Amplifier Function

Thus, rather than considering *gain*, we will analyze the overall nonlinear behavior of the cascade in response to a simple dc input, corresponding to the  $V_{IN}$  of Equation (1). For very small inputs, the output from the first cell is  $V_1 = AV_{IN}$ ; from the second,  $V_2 = A^2 V_{IN}$ , and so on, up to  $V_N = A^N V_{IN}$ . At a certain value of  $V_{IN}$ , the input to the Nth cell,  $V_{N-1}$ , is exactly equal to the knee voltage  $E_K$ . Thus,  $V_{OUT} = AE_K$  and since there are  $N-1$  cells of gain A ahead of this node, we can calculate that  $V_{IN} = E_K/A^{N-1}$ . This unique point corresponds to the *lin-log transition*,

labeled ① on Figure 22. Below this input, the cascade of gain cells is acting as a simple linear amplifier, while for higher values of  $V_{IN}$ , it enters into a series of segments which lie on a logarithmic approximation.

Continuing this analysis, we find that the next transition occurs when the input to the (N-1)th stage just reaches  $E_K$ , that is, when  $V_{IN} = E_K/A^{N-2}$ . The output of this stage is then exactly  $AE_K$ . It is easily demonstrated (from the function shown in Figure 21) that the output of the final stage is  $(2A-1)E_K$  (labeled ② on Figure 22). Thus, the output has changed by an amount  $(A-1)E_K$  for a change in  $V_{IN}$  from  $E_K/A^{N-1}$  to  $E_K/A^{N-2}$ , that is, a *ratio* change of A.

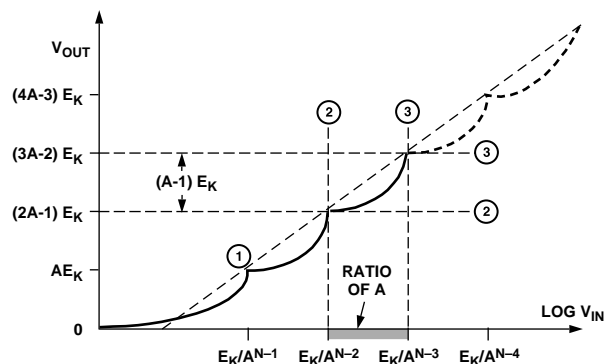

Figure 22. The First Three Transitions

At the next critical point, labeled ③, the input is A times larger and  $V_{OUT}$  has increased to  $(3A-2)E_K$ , that is, by another *linear* increment of  $(A-1)E_K$ . Further analysis shows that, right up to the point where the input to the first cell reaches the knee voltage,  $V_{OUT}$  changes by  $(A-1)E_K$  for a *ratio* change of A in  $V_{IN}$ . Expressed as a certain fraction of a decade, this is simply  $\log_{10}(A)$ .

For example, when  $A = 5$  a transition in the piecewise linear output function occurs at regular intervals of 0.7 decade ( $\log_{10}(A)$ ), or 14 dB divided by 20 dB). This insight allows us to immediately state the “Volts per Decade” scaling parameter, which is also the “Scaling Voltage”  $V_Y$  when using base-10 logarithms:

$$V_Y = \frac{\text{Linear Change in } V_{OUT}}{\text{Decades Change in } V_{IN}} = \frac{(A-1)E_K}{\log_{10}(A)} \quad (4)$$

Note that only two design parameters are involved in determining  $V_Y$ , namely, the cell gain A and the knee voltage  $E_K$ , while N, the number of stages, is unimportant in setting the slope of the overall function. For  $A = 5$  and  $E_K = 100$  mV, the slope would be a rather awkward 572.3 mV per decade (28.6 mV/dB). A well designed practical log amp will provide more rational scaling parameters.

The intercept voltage can be determined by solving Equation (4) for any two pairs of transition points on the output function (see Figure 22). The result is:

$$V_X = \frac{E_K}{A^{(N+1)/(A-1)}} \quad (5)$$

For the example under consideration, using  $N = 6$ ,  $V_X$  evaluates to 4.28  $\mu\text{V}$ , which thus far in this analysis is still a simple dc voltage.

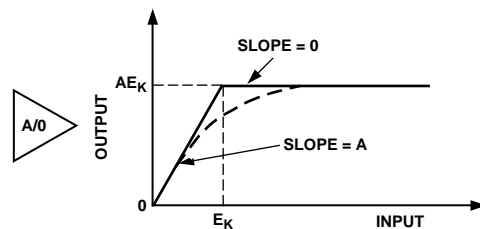

Figure 23. A/O Amplifier Functions (Ideal and tanh)

Care is needed in the interpretation of this parameter. It was earlier defined as the input voltage at which the output passes through zero (see Figure 19). Clearly, in the absence of noise and offsets, the output of the amplifier chain shown in Figure 20 can only be zero when  $V_{IN} = 0$ . This anomaly is due to the finite gain of the cascaded amplifier, which results in a failure to maintain the logarithmic approximation below the “lin-log transition” (Point ① in Figure 22). Closer analysis shows that the voltage given by Equation (5) represents the *extrapolated*, rather than actual, intercept.

### Demodulating Log Amps

Log amps based on a cascade of A/1 cells are useful in baseband (pulse) applications, because they do not demodulate their input signal. Demodulating (detecting) log-limiting amplifiers such as the AD8309 use a different type of amplifier stage, which we will call an A/0 cell. Its function differs from that of the A/1 cell in that the gain above the knee voltage  $E_K$  falls to zero, as shown by the solid line in Figure 23. This is also known as the *limiter* function, and a chain of N such cells is often used alone to generate a hard limited output, in recovering the signal in FM and PM modes.

The AD640, AD606, AD608, AD8307, AD8309, AD8313 and other Analog Devices communications products incorporating a logarithmic IF amplifier all use this technique. It will be apparent that the output of the last stage cannot now provide a logarithmic output, since this remains unchanged for all inputs above the limiting threshold, which occurs at  $V_{IN} = E_K/A^{N-1}$ . Instead, the logarithmic output is generated by *summing the outputs of all the stages*. The full analysis for this type of log amp is only slightly more complicated than that of the previous case.

It can be shown that, for practical purpose, the intercept voltage  $V_X$  is identical to that given in Equation (5), while the slope voltage is:

$$V_Y = \frac{A E_K}{\log_{10}(A)} \quad (6)$$

An A/0 cell can be very simple. In the AD8309 it is based on a bipolar-transistor differential pair, having resistive loads  $R_L$  and an emitter current source  $I_E$ . This amplifier limiter cell exhibits an equivalent knee-voltage of  $E_K = 2kT/q$  and a small-signal gain of  $A = I_E R_L / E_K$ . The large signal transfer function is the hyperbolic tangent (see dotted line in Figure 23). This function is very precise, and the deviation from an ideal A/0 form is not detrimental. In fact, the “rounded shoulders” of the *tanh* function beneficially result in a lower ripple in the logarithmic conformance than that which would be obtained using an ideal A/0 function. A practical amplifier chain built of these cells is differential in structure from input to final output, and has a low

# AD8309

sensitivity to disturbances on the supply lines. With careful design, the sensitivities to many other parametric variations, and the effects of temperature and supply voltage, can be reduced to negligible proportions.

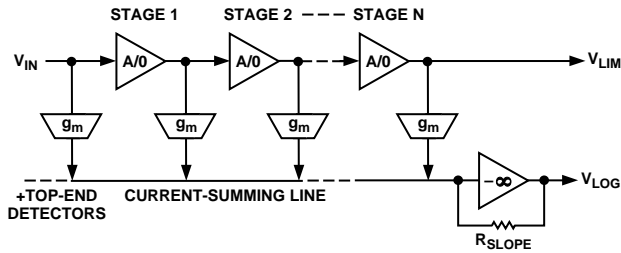

Figure 24. Basic Log Amp Structure Using A/O Stages and Transconductance ( $g_m$ ) Cells for Summing

The output of each gain cell has an associated transconductance ( $g_m$ ) cell, which converts the differential output voltage of the cell to a pair of differential currents; these are summed by simply connecting the outputs of all the  $g_m$  (detector) stages in parallel. The total current is then converted back to a voltage by a transresistance stage, which determines the slope of the logarithmic output. This general scheme is depicted, in a simplified single-sided form, in Figure 24. Additional detectors, driven by a passive attenuator, may be added to extend the top end of the dynamic range.

The slope voltage may now be decoupled from the knee-voltage  $E_K = 2kT/q$ , which is inherently PTAT. The detector stages are biased with currents (not shown in the Figure) which can be derived from a band-gap reference and thus be stable with temperature. This is the architecture used in the AD8309. It affords complete control over the magnitude and temperature behavior of the logarithmic slope.

A further step is yet needed to achieve the *demodulation response*, required in a log-limiter amp is to convert an alternating input into a quasi-dc baseband output. This is achieved by modifying the  $g_m$  cells used for summation purposes to implement the rectification function. Early log amps based on the progressive compression technique used half-wave rectifiers, which made post-detection filtering difficult. The AD640 was the first commercial monolithic log amp to use a full-wave rectifier; this proprietary practice has been used in all subsequent Analog Devices types.

We can model these detectors as being essentially linear  $g_m$  cells, but producing an output current that is independent of the sign of the voltage applied to the input. That is, they implement the *absolute-value function*. Since the output from the later A/O stages closely approximates an amplitude symmetric square wave for even moderate input levels, the current output from each detector is almost constant over each period of the input. Somewhat earlier detectors stages in the chain produce a waveform having only very brief “dropouts” at twice the input frequency. Only those detectors nearest the log amp’s input produce a low level waveform that is approximately sinusoidal. When all these (current mode) outputs are summed, the resulting signal has a waveform which is readily filtered, to provide a low residual ripple on the output.

## Intercept Calibration

Monolithic log amps from Analog Devices incorporate accurate means to position the intercept voltage  $V_X$  (or equivalent sine-wave power for a demodulating log amp, when driven at a specific impedance level). Using the scheme shown in Figure 24, the value of the intercept level departs considerably from that predicted by the simple theory. Nevertheless, the *intrinsic* intercept voltage is still proportional to  $E_K$ , which is PTAT (proportional to absolute temperature).

Recalling that the addition of an offset to the output produces an effect which is indistinguishable from a change in the position of the intercept, it will be apparent that we can cancel the “left-right” motion of  $V_X$  resulting from the temperature variation of  $E_K$  by simply adding an offset at its demodulated output having the required temperature behavior.

The precise temperature-shaping of the intercept-positioning offset can result in a log amp having stable scaling parameters, making it a true measurement device, for example, as a calibrated Received Signal Strength Indicator (RSSI). In this application, one is more interested in the value of the output for an input waveform which is often sinusoidal (CW). The input level be stated as an equivalent power, in dBm, but it is essential to know the impedance level at which this “power” is presumed to be measured. In an impedance of 50  $\Omega$ , 0 dBm (1 mW) corresponds to a sinusoidal *amplitude* of 316.2 mV (223.6 mV rms).

For the AD8309, the intercept may be specified in dBm when the input impedance is lowered to 50  $\Omega$ , by the addition of a shunt resistor of 52.3  $\Omega$ , in which case it occurs at  $-95$  dBm. However, the response is actually to the *voltage* at the input, not the *power* in the termination resistor, and should be specified in dBV. A  $-95$  dBm sine input across a 50  $\Omega$  resistance corresponds to an amplitude of 5.6  $\mu$ V, or  $-108$  dBV, where 0 dBV is specified as a sine waveform of 1 V rms, that is, 2.8 V p-p.

Note that a log amp’s intercept is a function of waveform. For example, a square-wave input will read 6 dB higher than a sine-wave of the same *amplitude*, and a Gaussian noise input 0.5 dB higher than a sine wave of the same *rms value*. Further, a log amp driven by the sum of two sinusoidal voltages of equal amplitude will show an output that is only 2.1 dB higher than the response for a single sine wave drive, rather than the 3 dB that might be expected if the device truly responded to input power. These are characteristics exhibited by all demodulating log amps.

## Dynamic Range

The lower end of the dynamic range is determined largely by the thermal noise floor, measured at the input of the amplifier chain. For the AD8309, the short-circuit input-referred noise-spectral density is 1.1 nV/ $\sqrt{\text{Hz}}$ , and 1.275 nV/ $\sqrt{\text{Hz}}$  when driven from a net source impedance of 25  $\Omega$  (a terminated 50  $\Omega$ ). This corresponds to a noise power of  $-78$  dBm in a 500 MHz bandwidth.

The upper end of the dynamic range is extended upward by the addition of *top-end detectors* driven by a tapped attenuator. These smaller signals are applied to additional full-wave detectors whose outputs are summed with those of the main detectors. With care in design, this extension in the dynamic range can be ‘seamless’ over the full frequency range. For the AD8309 it amounts to a further 48 dB. When using a supply of 4.5 V or greater, an input amplitude of 4 V can be accommodated, corresponding to a power level of  $+22$  dBm in 50  $\Omega$ . (A larger input voltage may cause damage.)

The total dynamic range of the AD8309, defined as the ratio of the maximum permissible input to the noise floor, is thus 100 dB. Good accuracy is provided over a substantial part of this range.

### Input Matching

Monolithic log amps present a nominal input impedance much higher than  $50\ \Omega$ . For the AD8309, this can be modeled as  $1\ \text{k}\Omega$  shunted by  $2.5\ \text{pF}$ , at frequencies up to  $300\ \text{MHz}$ . Thus, a simple input matching network can considerably improve the *basic sensitivity*, when driving from a low-impedance source, by increasing the voltage applied to the input. For a  $50:1000\ \Omega$  transformation, the voltage gain is  $13\ \text{dB}$ , and the whole dynamic range moves downward by this amount; that is, the intercept is shifted to  $-121\ \text{dBV}$  ( $-108\ \text{dBm}$  at the primary  $50\ \Omega$  input). Note that while useful voltage gain is achieved in this way, it does not follow that the noise-figure is minimal at the optimum power match.

### Offset Control

In a monolithic log amp, direct-coupling between the stages is invariably utilized for practical reasons. Now, a dc offset voltage in the early stages of the chain is indistinguishable from a “real” signal. If as high as  $400\ \mu\text{V}$ , it would be  $20\ \text{dB}$  larger than the smallest resolvable ac signal ( $40\ \mu\text{V}$ ), reducing the dynamic range by this amount. This problem is solved by using a global feedback path from the last stage to the first. The high-frequency components of the signal must be removed; this achieved in the AD8309 by an on-chip low-pass filter, providing sufficient suppression of HF feedback to allow accurate operation down to at least  $5\ \text{MHz}$ . Useful operation at lower frequencies remains possible, although a particular device having a large dc offset will exhibit a reduction in the low end region of the dynamic range.

## PRODUCT OVERVIEW

The AD8309 is built on an advanced dielectrically-isolated complementary bipolar process using thin-film resistor technology for accurate scaling. It follows well-developed foundations proven over a period of some fifteen years, with constant refinement. The backbone of the AD8309 (Figure 25) comprises a chain of six main amplifier/limiter stages, each having a gain of  $12.04\ \text{dB}$  ( $\times 4$ ) and small-signal  $-3\ \text{dB}$  bandwidth of  $850\ \text{MHz}$ . The input interface at INHI and INLO (Pins 4 and 5) is fully differential. Thus it may be driven from either single-sided or balanced inputs, the latter being required at the very top end of the dynamic range, where the total differential drive may be as large as  $4\ \text{V}$  in amplitude.

The first six stages, also used in developing the logarithmic RSSI output, are followed by a versatile programmable output, and thus programmable gain, final limiter section. Its open-collector outputs are also fully differential, at LMHI and LMLO (Pins 12 and 13). This output stage provides a gain of  $18\ \text{dB}$  when using equal valued load and bias setting resistors and the pin-to-pin output is used. The *overall* voltage gain is thus  $100\ \text{dB}$ . When using  $R_{\text{LIM}} = R_{\text{LOAD}} = 200\ \Omega$ , the additional current consumption in the limiter is approximately  $2.8\ \text{mA}$ , of which  $2\ \text{mA}$  goes to the load. The ratio depends on  $R_{\text{LIM}}$  (for example, when  $20\ \Omega$ , the efficiency is  $90\%$ ), and the voltage at the pin LMDR is rather more than  $400\ \text{mV}$ , but the total load current is accurately  $(400\ \text{mV})/R_{\text{LIM}}$ .

The rise and fall times of the hard-limited (essentially square-wave) voltage at the outputs are typically  $0.4\ \text{ns}$ , when driven by

a sine wave input having an amplitude of  $100\ \text{mV}$  or greater, and  $R_{\text{LOAD}} = 50\ \Omega$ . The change in time-delay (“phase skew”) over the input range  $-83\ \text{dBV}$  ( $100\ \text{mV}$  in amplitude, or  $-70\ \text{dBm}$  in  $50\ \Omega$ ) to  $-3\ \text{dBV}$  ( $1\ \text{V}$  or  $+10\ \text{dBm}$ ) is  $\pm 83\ \text{ps}$  ( $\pm 3^\circ$  at  $100\ \text{MHz}$ ).

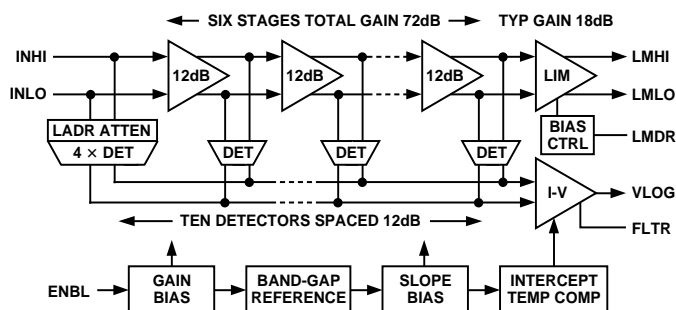

Figure 25. Main Features of the AD8309

The six main cells and their associated full-wave detectors, having a transconductance ( $g_m$ ) form, handle the lower part of the dynamic range. Biasing for these cells is provided by two references, one of which determines their gain, the other being a band-gap cell which determines the logarithmic slope, and stabilizes it against supply and temperature variations. A special dc-offset-sensing cell (not shown in Figure 25) is placed at the end of this main section, and used to null any residual offset at the input, ensuring accurate response down to the noise floor. The first amplifier stage provides a short-circuited voltage-noise spectral-density of  $1.07\ \text{nV}/\sqrt{\text{Hz}}$ .

The last detector stage includes a modification to temperature-stabilize the log-intercept, which is accurately positioned so as to make optimal use of the full output voltage range. Four further “top end” detectors are placed at  $12.04\ \text{dB}$  taps along a passive attenuator, to handle the upper part of the range. The differential current-mode outputs of all ten detectors stages are summed with equal weightings and converted to a single-sided voltage by the output stage, generating the logarithmic (or RSSI) output at VLOG (Pin 16), nominally scaled  $20\ \text{mV/dB}$  (that is,  $400\ \text{mV}$  per decade). The junction between the lower and upper regions is seamless, and the logarithmic law-conformance is typically well within  $\pm 0.4\ \text{dB}$  from  $-83\ \text{dBV}$  to  $+7\ \text{dBV}$  ( $-70\ \text{dBm}$  to  $+10\ \text{dBm}$ ).

The full-scale rise time of the RSSI output stage, which operates as a two-pole low-pass filter with a corner frequency of  $3.5\ \text{MHz}$ , is about  $200\ \text{ns}$ . A capacitor connected between FLTR (Pin 10) and VLOG can be used to lower the corner frequency (see below). The output has a minimum level of about  $0.34\ \text{V}$  (corresponding to a noise power of  $-78\ \text{dBm}$ , or  $17\ \text{dB}$  above the nominal intercept of  $-95\ \text{dBm}$ ). This rather high baseline level ensures that the pulse response remains unimpaired at very low inputs.

The maximum RSSI output depends on the supply voltage and the load. An output of  $2.34\ \text{V}$ , that is,  $20\ \text{mV/dB} \times (12 + 105)\ \text{dB}$ , is guaranteed when using a supply voltage of  $4.5\ \text{V}$  or greater and a load resistance of  $50\ \Omega$  or higher, for a differential input of  $9\ \text{dBV}$  (a  $4\ \text{V}$  sine amplitude, using balanced drives). When using a  $3\ \text{V}$  supply, the maximum differential input may still be as high as  $-3\ \text{dBV}$  ( $1\ \text{V}$  sine amplitude), and the corresponding RSSI output of  $2.1\ \text{V}$ , that is,  $20\ \text{mV/dB} \times (0 + 105)\ \text{dB}$  is also guaranteed.

# AD8309

A fully-programmable output interface is provided for the hard-limited signal, permitting the user to establish the optimal output current from its differential current-mode output. Its magnitude is determined by the resistor  $R_{LIM}$  placed between LMDR (Pin 9) and ground, across which a nominal bias voltage of  $\sim 400$  mV appears. Using  $R_{LIM} = 200 \Omega$ , this dc bias current, which is commutated alternately to the output pins, LMHI and LMLO, by the signal, is 2 mA. (The total supply current is somewhat higher).

These currents may readily be converted to voltage form by the inclusion of load resistors, which will typically range from a few tens of ohms at 500 MHz to as high as 2 k $\Omega$  in lower frequency applications. Alternatively, a resonant load may be used to extract the fundamental signal and modulation sidebands, minimizing the out-of-band noise. A transformer or impedance matching network may also be used at this output. The peak voltage swing down from the supply voltage may be 1.2 V, before the output transistors go into saturation. (The Applications section provides further information on the use of this interface).

The supply current for all sections except the limiter output stage, and with no load attached to the RSSI output, is nominally 16 mA at  $T_A = 27^\circ\text{C}$ , substantially independent of supply voltage. It varies in direct proportion to the absolute temperature (PTAT). The RSSI load current is simply the voltage at VLOG divided by the load resistance (e.g., 2.4 mA max in a 1 k $\Omega$  load). The limiter supply current is 1.1 times that flowing in  $R_{LIM}$ . The AD8309 may be enabled/disabled by a CMOS-compatible level at ENBL (Pin 8).

In the following simplified interface diagrams, the components denoted with an uppercase "R" are thin-film resistors having a very low temperature-coefficient of resistance and high linearity under large-signal conditions. Their absolute value is typically within  $\pm 20\%$ . Capacitors denoted using an uppercase "C" have a typical tolerance of  $\pm 15\%$  and essentially zero temperature or voltage sensitivity. Most interfaces have additional small junction capacitances associated with them, due to active devices or ESD protection; these may be neither accurate nor stable. Component numbering in each of these interface diagrams is local.

### Enable Interface

The chip-enable interface is shown in Figure 26. The current in R1 controls the turn-on and turn-off states of the band-gap reference and the bias generator, and is a maximum of 100  $\mu\text{A}$  when Pin 8 is taken to 5 V. Left unconnected, or at any voltage below 1 V, the AD8309 will be disabled, when it consumes a sleep current of much less than 1  $\mu\text{A}$  (leakage currents only); when tied to the supply, or any voltage above 2 V, it will be fully enabled. The internal bias circuitry requires approximately 300 ns for either OFF or ON, while a delay of some 6  $\mu\text{s}$  is required for the supply current to fall below 10  $\mu\text{A}$ .

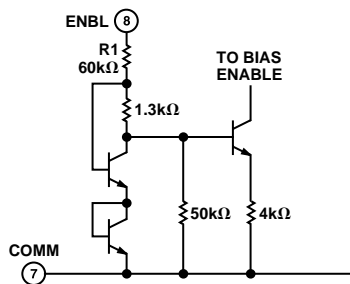

Figure 26. Enable Interface

### Input Interface

Figure 27 shows the essentials of the signal input interface. The parasitic capacitances to ground are labeled  $C_P$ ; the differential input capacitance,  $C_D$ , mainly due to the diffusion capacitance of Q1 and Q2. In most applications both input pins are ac-coupled. The switch S closes when Enable is asserted. When disabled, the inputs float, bias current  $I_E$  is shut off, and the coupling capacitors remain charged. If the log amp is disabled for long periods, small leakage currents will discharge these capacitors. If they are poorly matched, charging currents at power-up can generate a transient input voltage which may block the lower reaches of the dynamic range until it has become much less than the signal.

In most applications, the input signal will be single-sided, and may be applied to either Pin 4 or 5, with the remaining pin ac-coupled to ground. Under these conditions, the largest input signal that can be handled is  $-3$  dBV (sine amplitude of 1 V) when operating from a 3 V supply; a  $+3$  dBV input may be handled using a supply of 4.5 V or greater. When using a fully-balanced drive, the  $+3$  dBV level may be achieved for the supplies down to 2.7 V and  $+9$  dBV using  $>4.5$  V. For frequencies in the range 10 MHz to 200 MHz these high drive levels are easily achieved using a matching network (see later). Using such a network, having an inductor at the input, the input transient is eliminated.

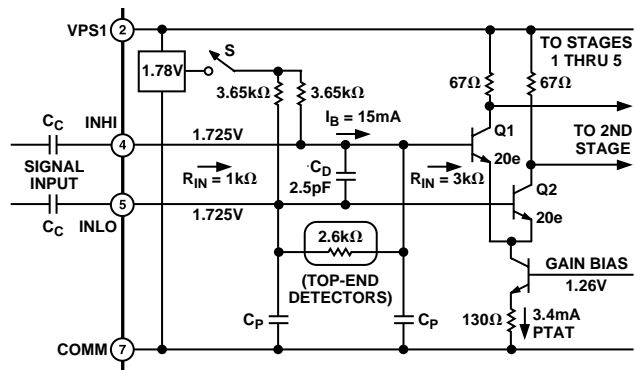

Figure 27. Signal Input Interface

### Limiter Output Interface

The simplified limiter output stage is shown in Figure 28. The bias for this stage is provided by a temperature-stable reference voltage of nominally 400 mV which is forced across the external resistor  $R_{LIM}$  connected from Pin 9 (LMDR, or limiter drive) by a special op amp buffer stage. The biasing scheme also introduces a slight "lift" to this voltage to compensate for the finite current gain of the current source Q3 and the output transistors Q1 and Q2. A maximum current of 10 mA is permissible ( $R_{LIM} = 40 \Omega$ ). In special applications, it may be desirable to modulate the bias current; an example of this is provided in the Applications section. Note that while the bias currents are temperature stable, the ac gain of this stage will vary with temperature, by  $-6$  dB over a  $120^\circ\text{C}$  range.

A pair of supply and temperature stable complementary currents is generated at the differential output LMHI and LMLO (Pins 12 and 13), having a square wave form with rise and fall times of typically 0.4 ns, when load resistors of 50  $\Omega$  are used. The voltage at these output pins may swing to 1.2 V below the supply voltage applied to VPS2 (Pin 15).

Because of the very high gain bandwidth product of this amplifier considerable care must be exercised in using the limiter outputs. The minimum necessary bias current and voltage swings should be used. These outputs are best utilized in a fully-differential mode. A flux-coupled transformer, a balun, or an output matching network can be selected to transform these voltages to a single-sided form. Equal load resistors are recommended, even when only one output pin is used, and these should always be returned to the same well decoupled node on the PC board. When the AD8309 is used only to generate an RSSI output, the limiter should be completely disabled by omitting  $R_{LIM}$  and strapping LMHI and LMLO to VPS2.

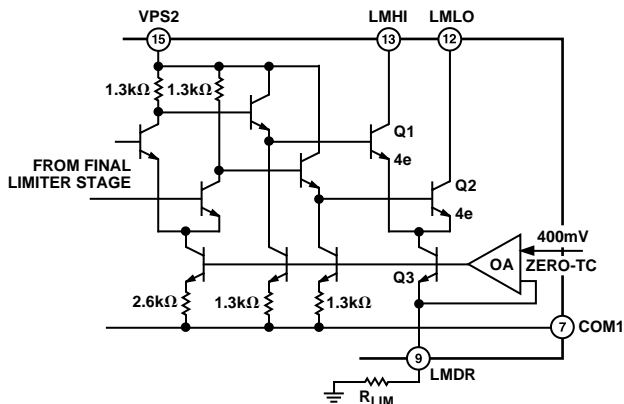

Figure 28. Limiter Output Interface

### RSSI Output Interface

The outputs from the ten detectors are differential currents, having an average value that is dependent on the signal input level, plus a fluctuation at twice the input frequency. The currents are summed at the internal nodes LGP and LGN shown in Figure 29. A further current  $I_{TC}$  is added to LGP, to position the intercept to  $-108$  dBV, by raising the RSSI output voltage for zero input, and to provide temperature compensation, resulting in a stable intercept. For zero signal conditions, all the detector output currents are equal. For a finite input, of either polarity, their difference is converted by the output interface to a single-sided voltage nominally scaled 20 mV/dB (400 mV per decade), at the output VLOG (Pin 16). This scaling is controlled by a separate feedback stage, having a tightly controlled transconductance. A small uncertainty in the log slope and intercept remains (see Specifications); the intercept may be adjusted (see Applications).

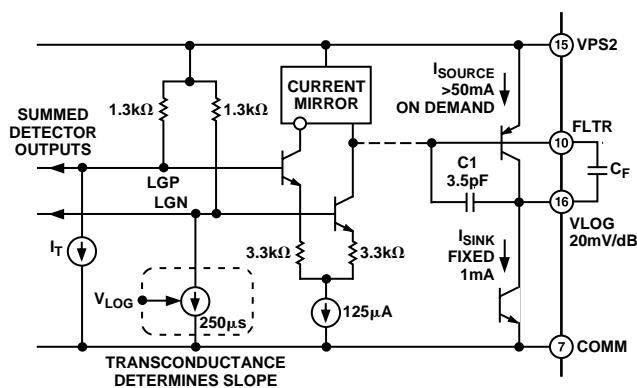

Figure 29. Simplified RSSI Output Interface

The RSSI output bandwidth,  $f_{LP}$ , is nominally 3.5 MHz. This is controlled by the compensation capacitor  $C_1$ , which may be increased by adding an external capacitor,  $C_F$ , between FLTR (Pin 10) and VLOG (Pin 16). An external 33 pF will reduce  $f_{LP}$  to 350 kHz, while 360 pF will set it to 35 kHz, in each case with an essentially one-pole response. In general, the relationships are:

$$C_F = \frac{12.7 \times 10^{-10}}{f_{LP}} - 3.5 \text{ pF}; \quad f_{LP} = \frac{12.7 \times 10^{-6}}{C_F + 3.5 \text{ pF}} \quad (7)$$

Using a load resistance of 50 Ω or greater, and at any temperature, the peak output voltage may be at least 2.4 V when using a supply of 4.5 V, and at least 2.1 V for a 3 V supply, which are consistent with the maximum permissible input levels. The incremental output resistance is approximately 0.3 Ω at low frequencies, rising to 1 Ω at 150 kHz and 18 Ω at very high frequencies.

The output is unconditionally stable with load capacitance, but it should be noted while the peak sourcing current is over 100 mA, and able to rapidly charge even large capacitances, the internally provided sinking current is only 1 mA. Thus, the fall time from the 2 V level will be as long as 2 μs for a 1 nF load. This may be reduced by adding a grounded load resistance.

### USING THE AD8309

The AD8309 exhibits very high gain from 1 MHz to over 1 GHz, at which frequency the gain of the main path is still over 65 dB. Consequently, it is susceptible to all signals within this very broad frequency range which find their way to the input terminals. It is important to remember that these are quite indistinguishable from the “wanted” signal, and will have the effect of raising the apparent noise floor (that is, lowering the useful dynamic range). Therefore, while the signal of interest may be an IF of, say, 200 MHz, any of the following could easily be larger than this signal at the lower extremities of its dynamic range: a 60 Hz hum, picked up due to poor grounding techniques; spurious coupling from digital logic on the same PC board; a strong EMI source; etc.

Very careful shielding is essential to guard against such unwanted signals, and also to minimize the likelihood of instability due to HF feedback from the limiter outputs to the input. With this in mind, the *minimum possible limiter gain* should be used. Where only the logarithmic amplifier (RSSI) function is required, the limiter should be disabled by omitting  $R_{LIM}$  and tying the outputs LMHI and LMLO directly to VPS2.

A good ground plane should be used to provide a low impedance connection to the common pins, for the decoupling capacitor(s) used at VPS1 and VPS2, and at the output ground. It is inadvisable to assume that any ground plane is an equipotential, however, and neither of the signal inputs should be ac-coupled directly to it, but kept separate, being returned instead to the “low” associated with the source. This requires isolating the “low” side of an input connector with a small resistance to the ground plane. Note that COM2 is a special ground pin serving just the RSSI output.

The voltages at the two supply pins should not be allowed to differ greatly; up to 500 mV is permissible. It is desirable to allow VPS1 to be slightly more negative than VPS2. When the primary supply is greater than 2.7 V, the decoupling resistors  $R_1$  and  $R_2$  may be increased to improve the isolation and lower dissipation in the IC. However, since VPS2 supports the RSSI

# AD8309

load current, which may be large, the value of R2 should take this into account.

The four pins labeled PADL tie down directly to the metallic lead frame, and are thus connected to the back of the chip. The process on which the AD8309 is fabricated uses a bonded-wafer technique to provide a silicon-on-insulator isolation, and there is no junction or other dc path from the back side to the circuitry on the surface. These paddle pins must be connected directly to the ground plane using the shortest possible lead lengths to minimize inductance.

## Basic Connections

Figure 30 shows the connections required for most applications. The inputs are ac-coupled by C1 and C2, which normally should have the same value, say, C<sub>O</sub>. The coupling time constant is R<sub>O</sub>C<sub>O</sub>/2, where R<sub>O</sub> = R<sub>S</sub> + R<sub>IN</sub>, thus forming a high pass corner with a 3 dB attenuation at f<sub>HP</sub> = 1/(π R<sub>T</sub> C<sub>C</sub>). In high-frequency applications, f<sub>HP</sub> should be chosen as large as possible, to minimize the coupling of unwanted signals. On the other hand, in low frequency applications, a simple RC network forming a low-pass filter should be added at the input for the same reason.

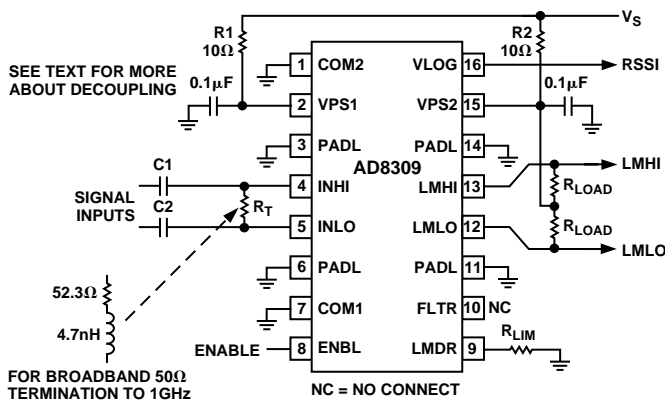

Figure 30. Basic Connections

Where it is necessary to terminate the source at a low impedance, the resistor R<sub>T</sub> should be added, with allowance for the shunting effect of the 1 kΩ input resistance (R<sub>IN</sub>) of the AD8309. For example, to terminate a 50 Ω source, a 52.3 Ω resistor should be used for signal frequencies up to about 50 MHz. The termination means may be placed either at the input or at the log amp side of the coupling capacitors. In the former case smaller capacitors can be used for a given frequency range; in the latter case, the dc resistance is lowered directly at the log amp inputs, which helps to keep offsets to a minimum. At higher frequencies, the reactance of the 2.5 pF input capacitance must be accounted for. A 4.7 nH inductor in series with the 52.3 Ω termination resistor provides an essentially flat 50 Ω input impedance to 1 GHz. An impedance-transforming network is preferably used to provide a 50 Ω interface, since this also introduces a balanced voltage gain of typically 13 dB and the AD8309 has a very high capacity for large input voltages.

Figure 31 shows the output versus the input level, with the axis marked in dBm (correct only when terminated in 50 Ω), for sine inputs at 5 MHz, 50 MHz, 100 MHz and 200 MHz. Figure 32 shows the typical logarithmic linearity (law conformance) under the same conditions.

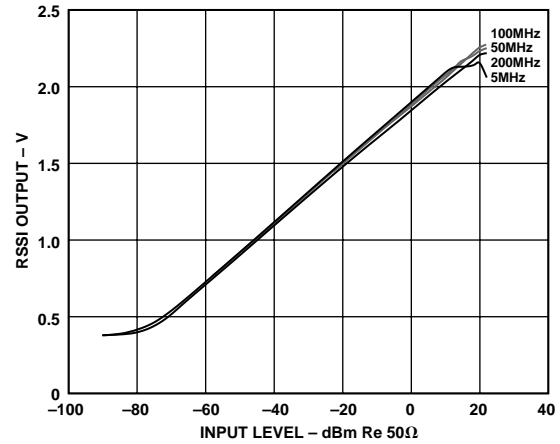

Figure 31. RSSI Output vs. Input Level at T<sub>A</sub> = +25°C, for Frequencies of 5 MHz, 50 MHz, 100 MHz and 200 MHz

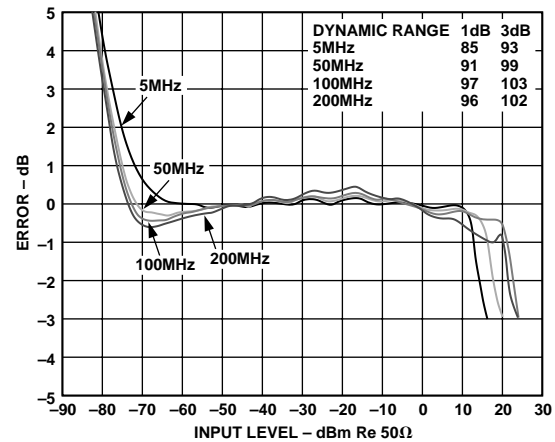

Figure 32. Log Linearity vs. Input Level at T<sub>A</sub> = +25°C, for Frequencies of 5 MHz, 50 MHz, 100 MHz and 200 MHz

## Input Matching

Where either a higher sensitivity or a better high frequency match is required, an input matching network is valuable. Using a flux-coupled transformer to achieve the impedance transformation also eliminates the need for coupling capacitors, lowers any dc offset voltages generated directly at the input, and usefully balances the drives to INHI and INLO, permitting full utilization of the unusually large input voltage capacity of the AD8309.

The choice of turns ratio will depend somewhat on the frequency. At frequencies below 30 MHz, the reactance of the input capacitance is much higher than the real part of the input impedance. In this frequency range, a turns ratio of 2:9 will lower the effective input impedance to 50 Ω while raising the input voltage by 13 dB. However, this does not lower the effect of the short circuit noise voltage by the same factor, since there will be a contribution from the input noise current. Thus, the total noise will be reduced by a smaller factor. The intercept at the primary input will be lowered to -120 dBV (-107 dBm).

Impedance matching and drive balancing using a flux-coupled transformer is useful whenever broadband coupling is required. However, this may not always be convenient. At high frequencies, it will often be preferable to use a narrow-band matching network, as shown in Figure 33, which has several advantages. First, the same voltage gain can be achieved, providing increased

sensitivity, but now a measure of *selectivity* is simultaneously introduced. Second, the component count is low: two capacitors and an inexpensive chip inductor are needed. Third, the network also serves as a balun. Analysis of this network shows that the amplitude of the voltages at INHI and INLO are quite similar when the impedance ratio is fairly high (say, 50 Ω to 1000 Ω).

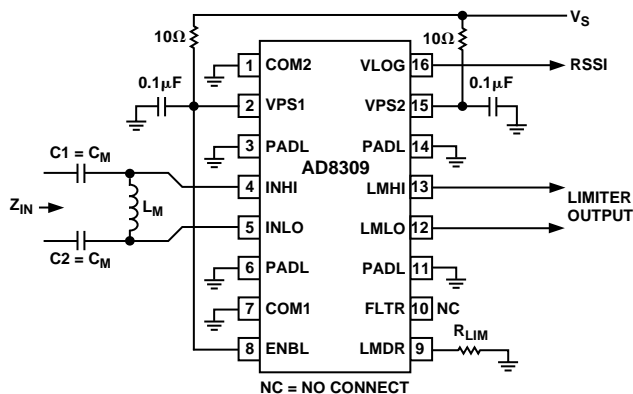

Figure 33. High Frequency Input Matching Network

Figure 34 shows the response for a center frequency of 100 MHz. The response is down by 50 dB at one-tenth the center frequency, falling by 40 dB per decade below this. The very high frequency attenuation is relatively small, however, since in the limiting case it is determined simply by the ratio of the AD8309's input capacitance to the coupling capacitors. Table I provides solutions for a variety of center frequencies  $f_C$  and matching from impedances  $Z_{IN}$  of nominally 50 Ω and 100 Ω. Exact values are shown, and some judgment is needed in utilizing the nearest standard values.

Table I.

$f_C$ MHz	Match to 50 Ω (Gain = 13 dB)		Match to 100 Ω (Gain = 10 dB)	
	$C_M$ pF	$L_M$ nH	$C_M$ pF	$L_M$ nH
10	140	3500	100.7	4790
10.7	133	3200	94.1	4460
15	95.0	2250	67.1	3120
20	71.0	1660	50.3	2290
21.4	66.5	1550	47.0	2120
25	57.0	1310	40.3	1790
30	47.5	1070	33.5	1460
35	40.7	904	28.8	1220
40	35.6	779	25.2	1047
45	31.6	682	22.4	912
50	28.5	604	20.1	804
60	23.7	489	16.8	644
80	17.8	346	12.6	448
100	14.2	262	10.1	335
120	11.9	208	8.4	261
150	9.5	155	6.7	191
200	7.1	104	5.03	125
250	5.7	75.3	4.03	89.1
300	4.75	57.4	3.36	66.8
350	4.07	45.3	2.87	52.1
400	3.57	36.7	2.52	41.8
450	3.16	30.4	2.24	34.3
500	2.85	25.6	2.01	28.6

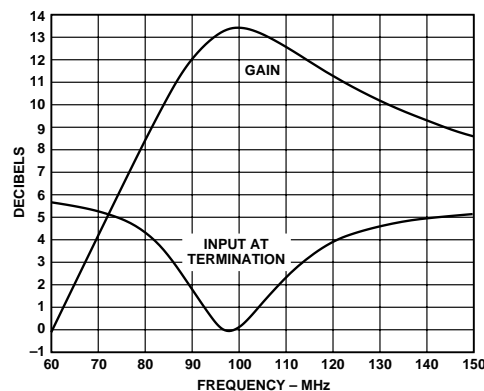

Figure 34. Response of 100 MHz Matching Network

### General Matching Procedure

For other center frequencies and source impedances, the following method can be used to calculate the basic matching parameters.

#### Step 1: Tune Out $C_{IN}$

At a center frequency  $f_C$ , the shunt impedance of the input capacitance  $C_{IN}$  can be made to disappear by resonating with a temporary inductor  $L_{IN}$ , whose value is given by

$$L_{IN} = 1 / \{ (2 \pi f_C)^2 C_{IN} \} = 10^{10} / f_C^2 \quad (8)$$

when  $C_{IN} = 2.5$  pF. For example, at  $f_C = 100$  MHz,  $L_{IN} = 1$  μH.

#### Step 2: Calculate $C_O$ and $L_O$

Now having a purely resistive input impedance, we can calculate the nominal coupling elements  $C_O$  and  $L_O$ , using

$$C_O = \frac{1}{2 \pi f_C \sqrt{(R_{IN} R_M)}}; \quad L_O = \frac{\sqrt{(R_{IN} R_M)}}{2 \pi f_C} \quad (9)$$

For the AD8309,  $R_{IN}$  is 1 kΩ. Thus, if a match to 50 Ω is needed, at  $f_C = 100$  MHz,  $C_O$  must be 7.12 pF and  $L_O$  must be 356 nH.

#### Step 3: Split $C_O$ Into Two Parts

Since we wish to provide the fully-balanced form of network shown in Figure 33, two capacitors  $C_1 = C_2$  each of nominally twice  $C_O$ , shown as  $C_M$  in the figure, can be used. This requires a value of 14.24 pF in this example. Under these conditions, the voltage amplitudes at INHI and INLO will be similar. A somewhat better balance in the two drives may be achieved when  $C_1$  is made slightly larger than  $C_2$ , which also allows a wider range of choices in selecting from standard values. For example, capacitors of  $C_1 = 15$  pF and  $C_2 = 13$  pF may be used (making  $C_O = 6.96$  pF).

#### Step 4: Calculate $L_M$

The matching inductor required to provide both  $L_{IN}$  and  $L_O$  is just the parallel combination of these:

$$L_M = L_{IN} L_O / (L_{IN} + L_O) \quad (10)$$

With  $L_{IN} = 1$  μH and  $L_O = 356$  nH, the value of  $L_M$  to complete this example of a match of 50 Ω at 100 MHz is 262.5 nH. The nearest standard value of 270 nH may be used with only a slight loss of matching accuracy. The voltage gain at resonance depends only on the ratio of impedances, as is given by

$$GAIN = 20 \log \left( \sqrt{\frac{R_{IN}}{R_S}} \right) = 10 \log \left( \frac{R_{IN}}{R_S} \right) \quad (11)$$

# AD8309

## Slope and Intercept Adjustment

The AD8309 provides limited opportunities for adjustment of its basic scaling parameters, which are controlled to within tight limits through robust design. In applications involving the observation of measured signal levels on a DVM a slope of 10 mV per decade is convenient: the reading is then directly in decibels, needing only the positioning of the decimal point. This may be simply achieved and at the same time trimmed to this exact value using the scheme shown in Figure 35. A large filter capacitor  $C_{FILT}$  may be added as shown when the voltage is to be measured on a DVM; this lowers the fluctuation in the lower-order display digits.

A precision attenuator or signal generator is required to provide several test levels at 10 dB intervals. The adjustment may also be made using an AM modulated signal, at about the center of the dynamic range. For a modulation depth  $M$ , expressed as a fraction, the decibel range between the peaks and troughs over one cycle of the modulation period is given by

$$\Delta dB = 20 \log_{10} (1+M)/(1-M) \quad (12)$$

For example, using an rms signal level of  $-40$  dBm with a 70% modulation depth ( $M = 0.7$ ), the decibel range is 15 dB, as the signal varies from  $-47.5$  dBm to  $-32.5$  dBm. The output would thus be adjusted to have a peak-to-peak amplitude of 150 mV.

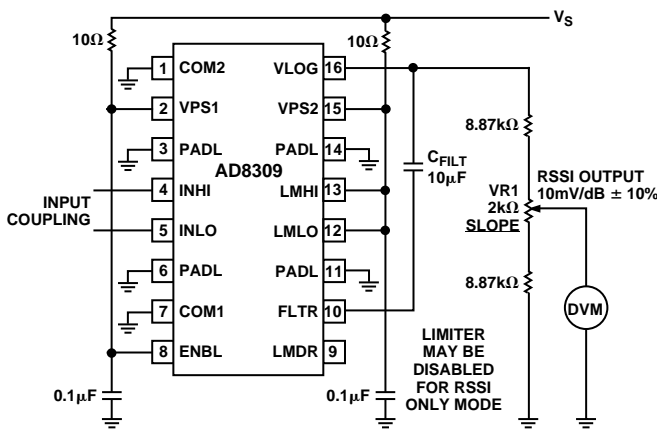

Figure 35. Trimming Slope to 10 mV/dB  $\pm$  10%

The intercept can be adjusted by the use of the auxiliary circuit shown in Figure 36, without changing the slope, which remains 20 mV/dB. This circuit provides a range of about  $\pm 4$  dB on a nominal intercept of  $-113$  dBV ( $-100$  dBm), with a fairly low residual temperature sensitivity ( $+0.008$  dB/ $^{\circ}$ C). This is sufficient to absorb the worst-case intercept error in the AD8309 plus system-level gain errors. VR2 is adjusted while applying an accurately known CW signal near the lower end of the dynamic range, in order to minimize the effect of any residual uncertainty in the slope. For example, to position the intercept to exactly  $-100$  dBm, a test level of  $-60$  dBm may be applied and VR2 adjusted to produce a dc output of 40 dB above the intercept, which is  $+0.8$  V. This trim can optionally be combined with the slope trim described above.

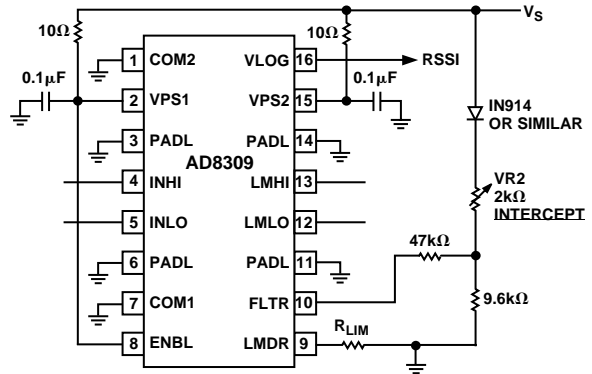

Figure 36. Trimming Intercept to  $-113$  dBV  $\pm$  4 dB

## APPLICATIONS

The AD8309 is a versatile and easily applied log-limiting amp. Being complete, it can be used with very few external components, and most applications can be accommodated using the simple connections shown in the preceding section. A few examples of more specialized applications are provided here.

### Log Amp with High Slope Voltage

Where a higher RSSI slope voltage is required, and/or complete calibration with good temperature stability and minimal interaction between trims, the interface shown in Figure 37 may be used. Note that at 50 mV/dB, the full 100 dB dynamic range of the AD8309 requires a 5 V swing. This can be provided by a single supply operational amplifier having a rail-to-rail output stage and operating from a 6 V supply. Where a lower range is sufficient, or when using the 40 mV/dB option, a 5 V supply will be adequate.

In this application, the supply current into the VPS2 pin is only slightly dependent on the current delivered to the load resistance,  $R_L$ , so a voltage dropping resistor,  $R_D$ , may be added to lower the supply to the AD8309, which can meet all of its specifications with a 2.7 V supply. The lower chip dissipation and the resulting reduction in operating temperature will minimize degradation of noise figure at high ambient temperatures.  $R_D$  is calculated as follows:

$$R_D = \frac{V_S - 3}{25 \text{ mA}} \quad (13)$$

$$R_{LIM} \geq 100 \Omega$$

which allows for operation at ambient temperatures up to  $+85^{\circ}$ C.

Table II may be used to select the component values for various different operating conditions. The slope adjustment range is  $\pm 10\%$  and the intercept adjustment range is  $\pm 3$  dB. Since the intercept offset bias is derived from the supply, there is a sensitivity to this voltage. Where supply stability is poor, a regulator may be needed to bias VR2 and R4.

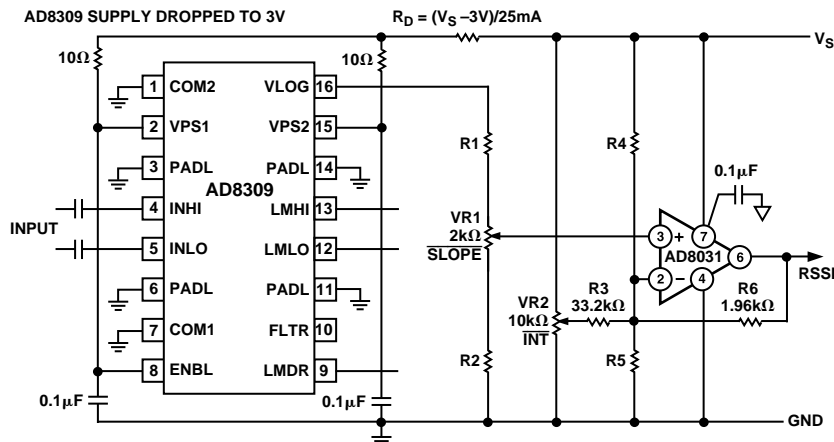

Figure 37. Buffered RSSI Output with Slope and Intercept Adjustments

Table II.

Slope mV/dB	Intercept dBV	R1 kΩ	R2 kΩ	R4 kΩ	R5 kΩ	V <sub>OUT</sub> (V) at	
						-88 dBV	+12 dBV
40	-102	3.92	8.87	O/C	1	0.56	4.56
50	-103	1.05	9.53	O/C	1	0.75	5.75
40	-90	3.92	8.87	20.5	1.05	0.08	4.08
50	-90	1.05	9.53	15.4	1.07	0.1	5.10

### Setting the Limiter Output Level

The limiter output is a pair of differential currents of magnitude,  $I_{OUT}$ , from high impedance (open-collector) sources. These are converted to equal-amplitude voltages by supply-referenced load resistors,  $R_{LOAD}$ . The limiter output current is set by  $R_{LIM}$ , the resistor connected between Pin 9 (LMDR) and ground depending on the application, the resulting voltage may be used in a fully balanced or unbalanced manner. It is good practice to retain the both resistors, whichever output mode is used. The unbalanced, or single sided mode, is more inclined to result in instabilities caused by the very high gain of the signal path. If the limiter output is not needed, LMDR should be left open with LMHI and LMLO being tied to VPS2.

The limiter output current is set by the equation:

$$I_{OUT} = -400 \text{ mV} / R_{LIM}$$

and has an absolute accuracy of  $\pm 5\%$ .

The voltage on each of the limiter pins will be given by:

$$V_{LIM} = V_S - 400 \text{ mV} \times R_{LOAD} / R_{LIM}$$

The limiter current may be set as high as 10 mA, which requires  $R_{LIM}$  to be 40 ohms, and can be optionally increased somewhat beyond this level. It is inadvisable, however, to use high bias currents, since the gain of this wide bandwidth signal path is proportional to it, and the risk of instability is elevated as  $R_{LIM}$  is reduced (recommended value is 400 Ω).

The limiter output is specified for input levels between -78 dBV and +9 dBV. The output of the limiter will be unstable for levels below -78 dBV (-65 dBm).

### High Output Limiter Loading

The AD8309 can generate a fairly large output power at its differential limiter output interface. This may be coupled into a 50 Ω grounded load using the narrow-band coupling network following similar lines to those provided for input matching. Alternatively, a flux-linked transformer, having a center-tapped primary, may be used. Even higher output powers can be obtained using emitter-followers. In Figure 38, the supply voltage to the AD8309 is dropped from 5 V to about 4.2 V, by the diode. This increases the available swing at each output to about 2 V. Taking both outputs differentially, a square wave output of 4 V p-p can be generated.

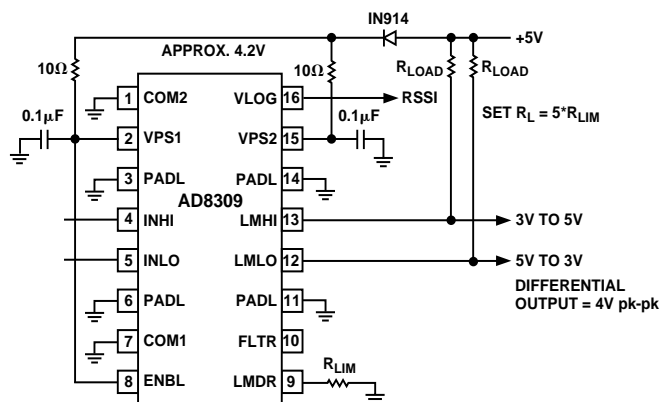

Figure 38. Increasing Limiter Output Voltage

When operating at high output power levels and high frequencies, very careful attention must be paid to the issue of stability. Oscillation is likely to be observed when the input signal level is low, due to the extremely high gain-bandwidth product of the AD8309 under such conditions. These oscillations will be less evident when signal-balancing networks are used, operating at frequencies below 200 MHz, and they will generally be fully quenched by the signal at input levels of a few dB above the noise floor.

# AD8309

## Modulated Limiter Output

The limiter output stage of the AD8309 also provides an analog multiplication capability: the amplitude of the output square wave can be controlled by the current withdrawn from LMDR (Pin 9). An analog control input of 0 V to +1 V is used to generate an exactly-proportional current of 0 mA to 10 mA in the npn transistor, whose collector is held at a fixed voltage of ~400 mV by the internal bias in the AD8309. When the input signal is above the limiting threshold, the output will then be a square-wave whose amplitude is proportional to the control bias.

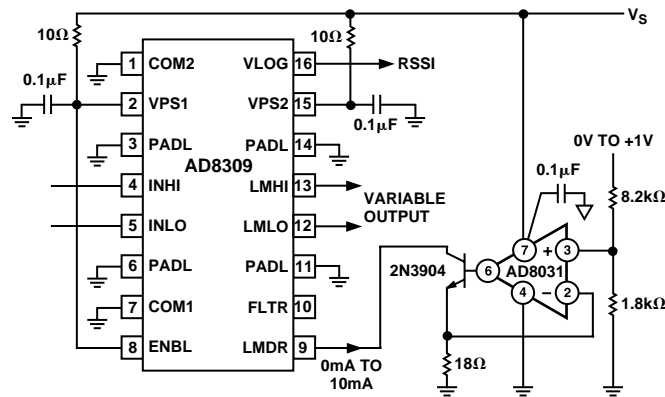

Figure 39. Variable Limiter Output Programming

## Effect of Waveform Type on Intercept

The AD8309 fundamentally responds to voltage and not to power. A direct consequence of this characteristic is that input signals of equal rms power, but differing crest factors, will produce different results at the log amp's output.

The effect of differing signal waveforms is to shift the effective value of the log amp's intercept. Graphically, this looks like a vertical shift in the log amp's transfer function. The device's logarithmic slope however is not affected. For example, consider

the case of the AD8309 being alternately fed by an unmodulated sine wave and by a single CDMA channel of the same rms power. The AD8309's output voltage will differ by the equivalent of 3.55 dB (71 mV) over the complete dynamic range of the device (the output for a CDMA input being lower).

Table III shows the correction factors that should be applied to measure the rms signal strength of a various signal types. A sine wave input is used as a reference. To measure the rms power of a square wave, for example, the mV equivalent of the dB value given in the table (20 mV/dB times 3.01 dB) should be subtracted from the output voltage of the AD8309.

Table III. Shift in AD8309 Output for Signals with Differing Crest Factors

Signal Type	Correction Factor (Add to Output Reading)
Sine Wave	0 dB
Square Wave or DC	-3.01 dB
Triangular Wave	+0.9 dB
GSM Channel (All Time Slots On)	+0.55 dB
CDMA Channel	+3.55 dB
PDC Channel (All Time Slots On)	+0.58 dB
Gaussian Noise	+2.51 dB

## Evaluation Board

An evaluation board, carefully laid out and tested to demonstrate the specified high speed performance of the AD8309 is available. Figure 40 shows the schematic of the evaluation board which fairly closely follows the basic connections schematic shown in Figure 30. For ordering information, please refer to the Ordering Guide. Links, switches and component settings for different setups are described in Table IV.

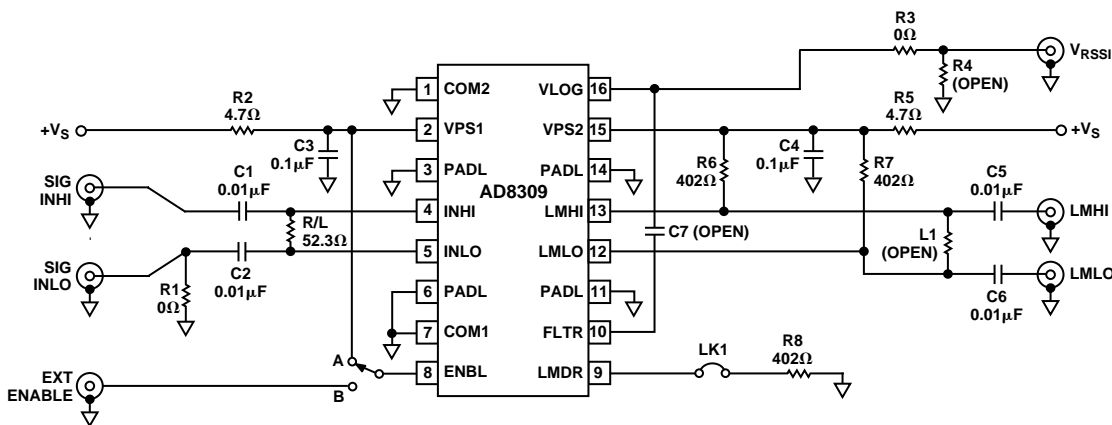

Figure 40. Evaluation Board Schematic

Table IV. Evaluation Board Setup Options

Component	Function	Default Condition
SW1	Device Enable. When in position A, the ENBL pin is connected to +V <sub>S</sub> and the AD8309 is in normal operating mode. In position B, the ENBL pin is connected to an SMA connector labeled Ext Enable. An applied signal can be applied to this connector to enable/disable the AD8309. If left open, the ENBL pin will float to ground putting the device in power-down mode.	SW1 = A
R1	This pad is used to ac-couple to ground for single-ended input drive. To drive the AD8309 differentially, R1 should be removed.	R1 = 0 Ω
R/L, C1, C2	Input Interface. The 52.3 Ω resistor in position R/L along with C1 and C2 create a high pass input filter whose corner frequency (640 kHz) is equal to $1/(\pi RC)$ , where $C = C1 = C2$ and R is the parallel combination of 52.3 Ω and the AD8309's input impedance of 1000 Ω. Alternatively, the 52.3 Ω resistor can be replaced by an inductor to form an input matching network. See Input Matching Network section for more details.	R/L = 52.3 Ω C1 = C2 = 0.01 μF
R3/R4	Slope Adjust. A simple slope adjustment can be implemented by adding a resistive divider at the VLOG output. R3 and R4, whose sum should be about 1 kΩ, and never less than 40 Ω (see specs), set the slope according to the equation: $Slope = 20 \text{ mV/dB} \times R4/(R3+R4)$ .	R3 = 0 Ω R4 = ∞
L1, C5, C6	Limiter Output Coupling. C5 and C6 ac-couple the limiter's differential outputs. By adjusting these values and installing an inductor in L1, an output matching network can be implemented.	L1 = Open C5 = 0.01 μF C6 = 0.01 μF
R8, LK1	Limiter Output Current. With LK2 installed, R8 enables and sets the limiter output current. The limiter's output current is set according to the equation ( $I_{OUT} = 400 \text{ mV/R8}$ ). The limiter current can be as high as 10 mA (R8 = 40 Ω). To disable the limiter (recommended if the limiter is not being used), LK3 should be removed.	LK1 Installed. R8 = 402 Ω
C7	RSSI Bandwidth Adjust. The addition of C7 will lower the RSSI bandwidth of the VLOG output according to the equation: $f_{CORNER} = 12.7 \times 10^{-6}/(C_{FILT} + 3.5 \text{ pF})$ .	C7 = Open

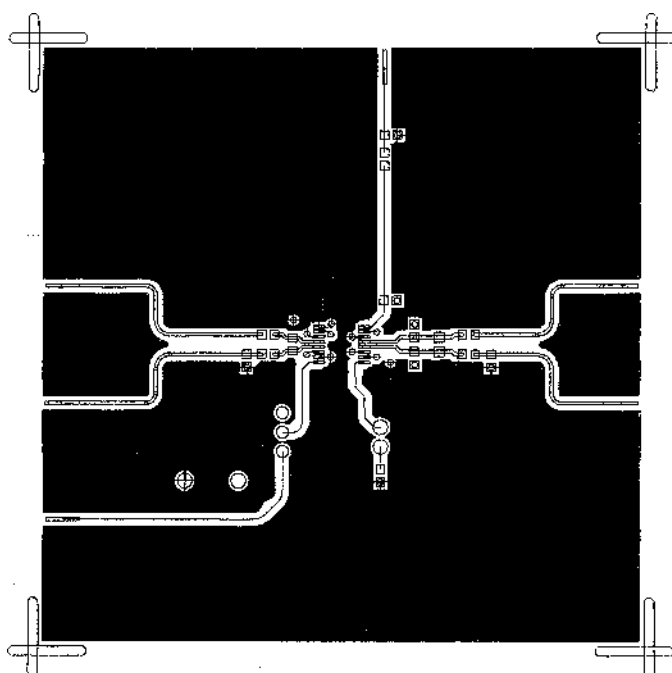

Figure 41. Layout of Signal Layer

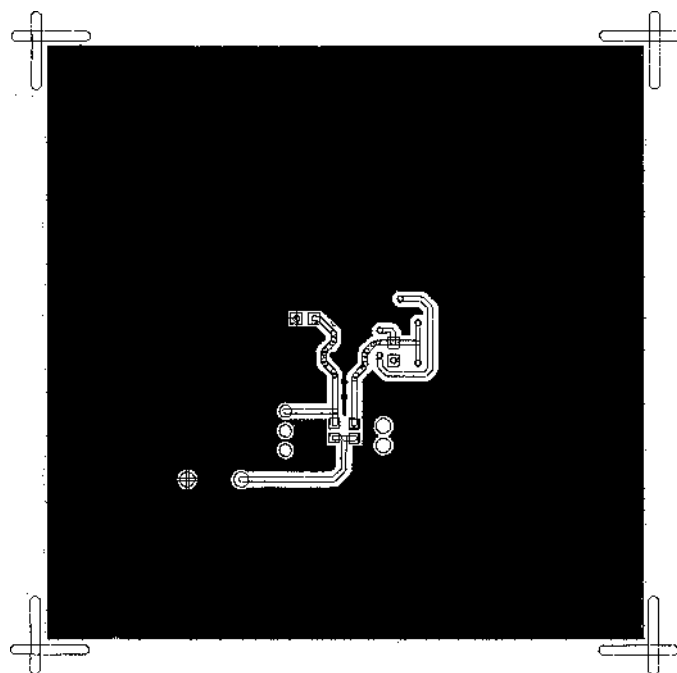

Figure 42. Layout of Power Layer

# AD8309

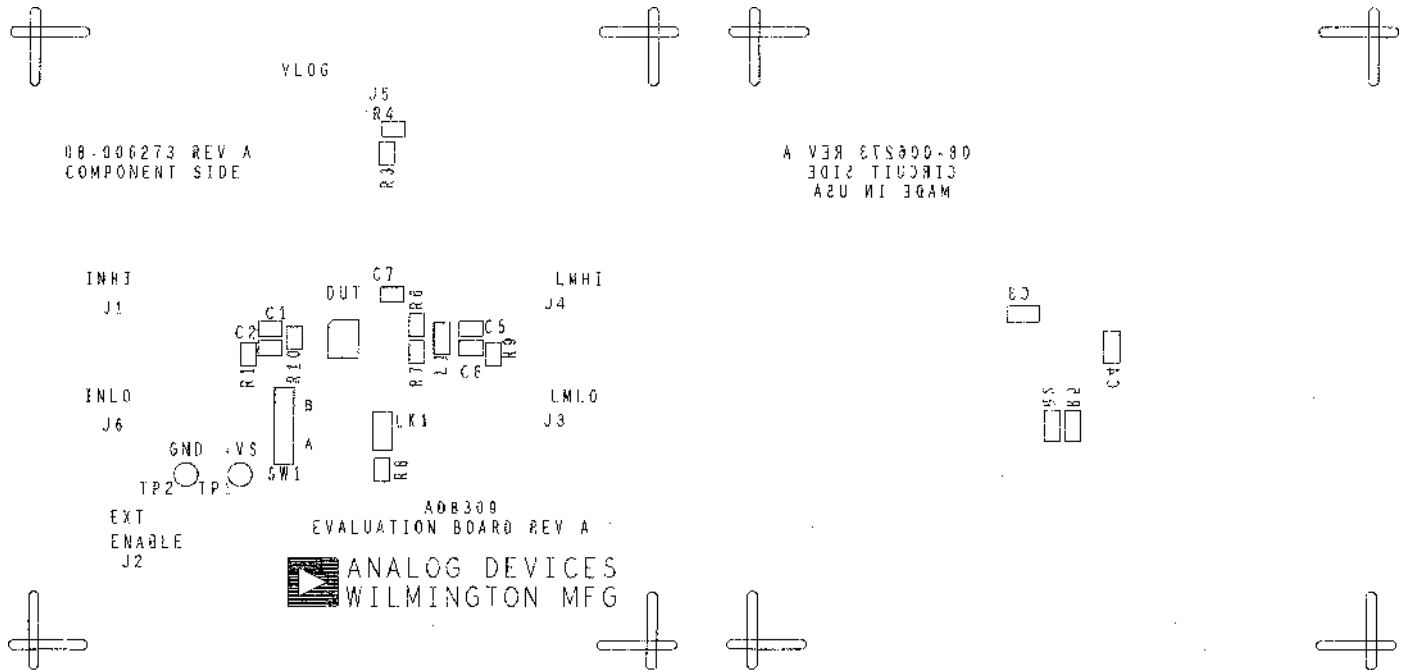

Figure 43. Signal Layer Silkscreen

Figure 44. Power Layer Silkscreen

## OUTLINE DIMENSIONS

Dimensions shown in inches and (mm).

### 16-Lead TSSOP (RU-16)

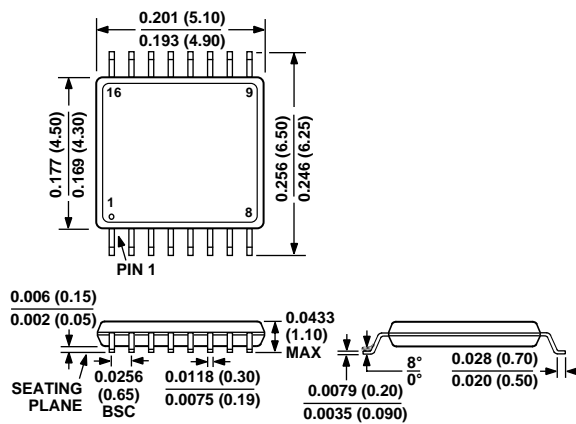



C3440b-0-8/99

PRINTED IN U.S.A.

## Looking for pricing, stock, or lifecycle information?

Click below to explore more details on WIN SOURCE:

-  [View AD8309ARUZ-REEL7 on WIN SOURCE](#)
-  [Analog Devices Inc. Information](#)

## Optimize Your Supply Chain with WIN SOURCE Solutions

-  Global Sourcing Solution
-  Obsolete Management
-  Cost Control Management
-  Shortage Management
-  Alternative Solution
-  Excess Inventory Management