



THE DATASHEET OF SP211EHEA-L



Revision History

Document No.	Release Date	Change Description
-	08	Legacy Sipex Datasheet.
1.0.0	10/28/10	Convert to Exar format, update ordering information and change rev to 1.0.0
1.0.1	June 2011	All options of SP208EH are discontinued per PDN 110510-01
1.0.2	3/26/20	Update to MaxLinear logo. Update Ordering Information.
2.0.0	10/21/20	Update to MaxLinear template. Remove obsolete SP211EH and WSOIC28 references. Add ESD ratings to page 1. Update maximum transmission rate, output voltage swing, input voltage range, instantaneous slew rate, transition time, I_{CC} , and maximum storage temperature. Update Transmitter Output graphs and add 1Mbps graphs. Update Transmitter / Driver section in Theory of Operation. Update Ordering Information. Changes made in accordance to PCN 20015.

Table of Contents

General Description	i
Features	i
Typical Application	i
Specifications	1
Absolute Maximum Ratings.....	1
ESD Ratings	1
Electrical Characteristics	2
Pin Information	4
Pin Configuration	4
Description	5
Theory Of Operation.....	5
Transmitter / Drivers.....	5
Receivers	5
Shutdown Mode	5
ENABLE	6
Wake-Up Function.....	6
Charge Pump	7
ESD Tolerance	8
EIA Standards	10
Typical Application Circuit	10
Mechanical Dimensions	11
SSOP28	11
Recommended Land Pattern and Stencil	12
SSOP28	12
Ordering Information	13

List of Figures

Figure 1: SP213EH Typical Application.....	i
Figure 2: Transmitter Output @ 240kbps $R_L = 3k\Omega$, $C_L = 1000pF$	3
Figure 3: Transmitter Output @ 500kbps $R_L = 3k\Omega$, $C_L = 1000pF$	3
Figure 4: SP213EH Pin Configuration	4
Figure 5: Wake-Up Timing.....	6
Figure 6: Typical Capacitor C2 Waveform With All Drivers at Maximum Load.....	7
Figure 7: Charge Pump - Phase 1	7
Figure 8: Charge Pump - Phase 2.....	7
Figure 9: Charge Pump - Phase 3.....	7
Figure 10: Charge Pump - Phase 4.....	8
Figure 11: ESD Test Circuit for Human Body Model	8
Figure 12: ESD Test Circuit for IEC61000-4-2	9
Figure 13: ESD Test Waveform for IEC61000-4-2	9
Figure 14: Typical SP213EH Application.....	10
Figure 15: Mechanical Dimensions, SSOP28.....	11
Figure 16: Recommended Land Pattern and Stencil, SSOP28.....	12

List of Tables

Table 1: Model Selection Table	i
Table 2: Absolute Maximum Ratings	1
Table 3: ESD Ratings	1
Table 4: Electrical Characteristics	2
Table 5: SP213EH Wake-Up Truth Table.....	6
Table 6: Transceiver ESD Tolerance Levels	10
Table 7: Ordering Information.....	13

Specifications

Absolute Maximum Ratings

Important: These are stress ratings only and functional operation of the device at these or any other above those indicated in the operation sections of the specification below is not implied. Exposure to absolute maximum ratings conditions for extended periods of time may affect reliability.

Table 2: Absolute Maximum Ratings

Parameter	Minimum	Maximum	Units
V_{CC}		6.0	V
V+	$V_{CC} - 0.3$	13.2	V
V-		13.2	V
Input Voltages			
T_{IN}	-0.3	$V_{CC} + 0.3$	V
R_{IN}		± 25	V
Output Voltages			
T_{OUT}	V+, 0.3V	V-, -0.3V	V
R_{OUT}	-0.3	$V_{CC} + 0.3$	V
Short Circuit Duration			
Tout		Continuous	
Power Dissipation per Package			
28-pin SSOP (derate 11.2mW / °C above +70°C)		900	mW

ESD Ratings

Table 3: ESD Ratings

Parameter	Limit	Units
HBM (Human Body Model), Driver Outputs and Receiver Inputs	± 15	kV
IEC61000-4-2 Air Discharge, Driver Outputs and Receiver Inputs, Level 4	± 15	kV
IEC61000-4-2 Contact Discharge, Driver Outputs and Receiver Inputs, Level 4	± 8	kV

Electrical Characteristics

V_{CC} at nominal ratings; 0.1 μ F charge pump capacitors; T_{MIN} to T_{MAX} , unless otherwise noted.

Table 4: Electrical Characteristics

Parameter	Test Condition	Minimum	Typical	Maximum	Units
TTL Inputs T_{IN} , EN, SD					
Logic threshold V_{IL}				0.8	V
Logic threshold V_{IH}		2.0			V
Logic pull-up current	$T_{IN} = 0V$		15	200	μ A
Maximum transmission rate	$C_L = 1000pF$, $R_L = 3k\Omega$	1			Mbps
TTL Outputs					
Compatibility		TTL / CMOS			
V_{OL}	$I_{OUT} = 3.2mA$, $V_{CC} = 5V$			0.4	V
V_{OH}	$I_{OUT} = -1.0mA$	3.5			V
Leakage current	$0V \leq V_{OUT} \leq V_{CC}$; EN = V_{CC} , $T_A = +25^\circ C$		0.05	± 10	μ A
RS-232 Output					
Output voltage swing	All transmitter outputs loaded with 3k Ω to ground	± 5	± 8.7		V
Output resistance	$V_{CC} = 0V$, $V_{OUT} = \pm 2V$	300			Ω
Output short circuit current	Infinite Duration, $V_{OUT} = 0V$		± 25		mA
RS-232 Input					
Voltage range	$T_A = 25^\circ C$	-25		25	V
Voltage threshold low	$V_{CC} = 5V$, $T_A = 25^\circ C$	0.8	1.2		V
Voltage threshold high	$V_{CC} = 5V$, $T_A = 25^\circ C$		1.7	2.8	V
Hysteresis	$V_{CC} = 5V$	0.2	0.5	1.0	V
Resistance	$V_{IN} = \pm 15V$, $T_A = 25^\circ C$	3	5	7	k Ω
Dynamic Characteristics					
Driver propagation delay	TTL to RS-232		250		ns
Receiver propagation delay	RS-232 to TTL		200	500	ns
Instantaneous slew rate	$C_L = 50pF$, $R_L = 7k\Omega$, $T_A = 25^\circ C$, from $\pm 3V$			150	V/ μ s
Transition time	$C_L = 2500pF$, $R_L = 3k\Omega$, measured from -3V to +3V or +3V to -3V			800	ns
Output enable time			400		ns
Output disable time			250		ns

Table 4: Electrical Characteristics

Parameter	Test Condition	Minimum	Typical	Maximum	Units
Power Requirements					
V _{CC}		4.50	5.00	5.50	V
I _{CC}	No load: V _{CC} = ±10%		3	8	mA
I _{CC}	All transmitters R _L = 3kΩ		23		mA
Shutdown current	T _A = 25°C		1	10	μA
Environmental and Mechanical					
Operating temperature	Commercial, _C	0		+70	°C
	Extended, _E	-40		+85	°C
Storage temperature		-65		+150	°C
Package	_A	Shrink (SSOP) small outline			

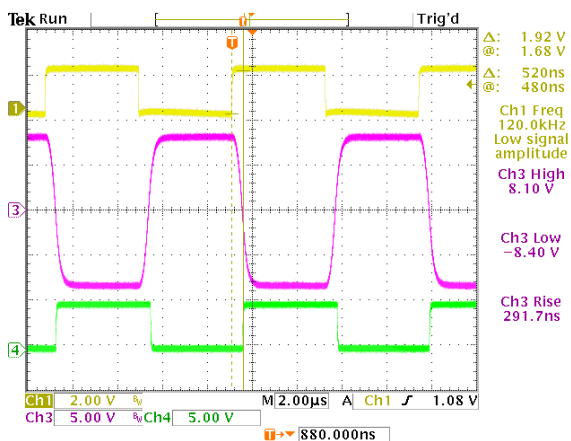

Figure 2: Transmitter Output @ 240kbps
R_L = 3kΩ, C_L = 1000pF

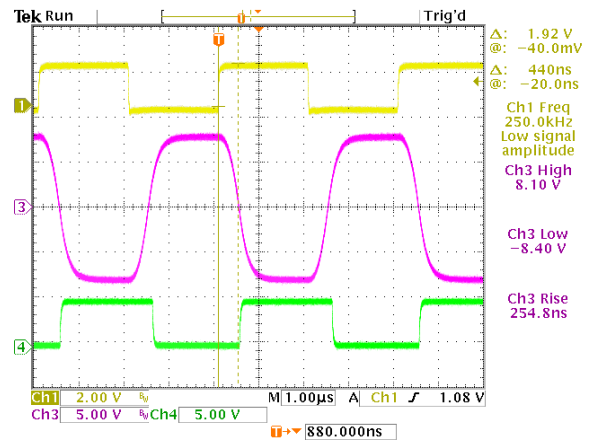

Figure 3: Transmitter Output @ 500kbps
R_L = 3kΩ, C_L = 1000pF

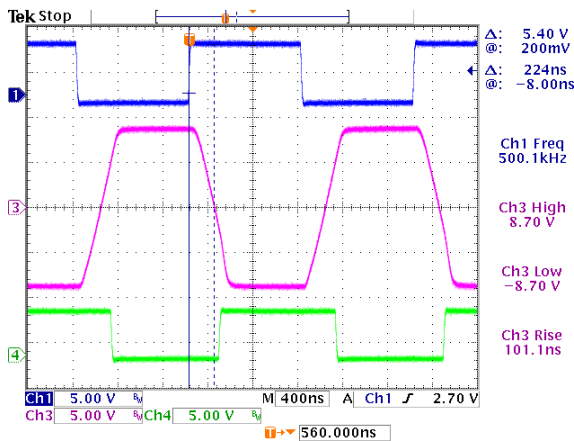

Figure 4: Transmitter Output @ 1Mbps
R_L = 3kΩ, C_L = 50pF

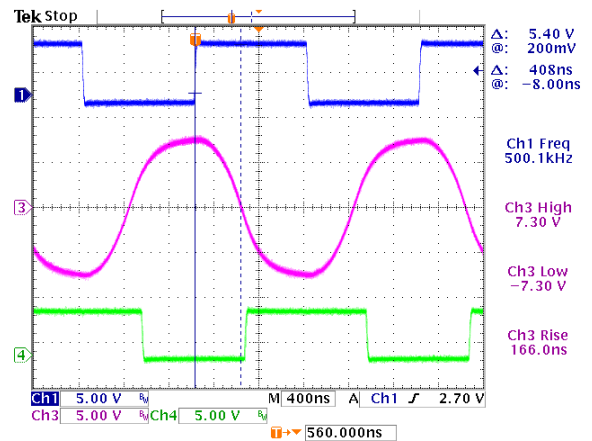

Figure 5: Transmitter Output @ 1Mbps
R_L = 3kΩ, C_L = 1000pF

Pin Information

Pin Configuration

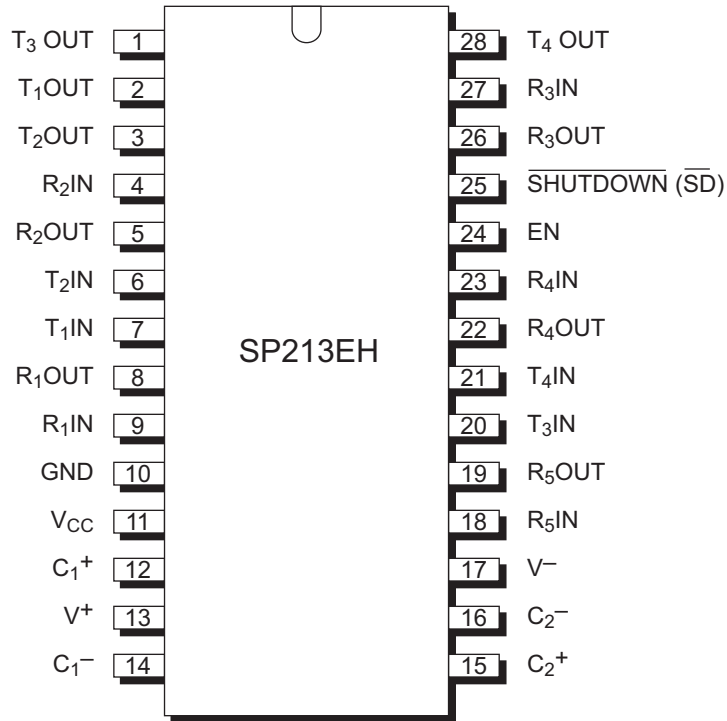

Figure 6: SP213EH Pin Configuration

Description

As in the original RS-232 multi-channel products, the SP213EH high speed multi-channel RS-232 line transceiver provides a variety of configurations to fit most designs, especially high speed applications where $\pm 12V$ is not available. The SP213EH is a superior high speed drop-in replacement to our previous versions as well as popular industry standards.

All devices in this series feature low-power CMOS construction and MaxLinear's proprietary on-board charge pump circuitry to generate the RS-232 signal voltages. The ability to use 0.1 μ F charge pump capacitors saves board space and reduces production costs. The devices in this series provide different driver / receiver combinations to match any application requirement.

The SP213EH models features a low-power shutdown mode, which reduces power supply drain current to 1 μ A. The SP213EH includes a Wake-Up function which keeps two receivers active in the shutdown mode, unless disabled by the EN pin.

The family is available in SSOP (shrink) small outline packages. Devices can be specified for commercial (0°C to +70°C) and industrial / extended (-40°C to +85°C) operating temperatures.

Theory Of Operation

The SP213EH device is made of three basic circuit blocks:

- Transmitter / driver
- Receiver
- The MaxLinear proprietary charge pump

Each model within the series incorporates variations of these circuits to achieve the desired configuration and performance.

Transmitter / Drivers

The drivers of this series can maintain a typical data rate of 1Mbps. This superior RS-232 data transmission rate makes the SP213EH series an ideal match for many designs in personal computer peripherals and LAN applications that demand high speed performance.

The drivers are inverting transmitters, which accept either TTL or CMOS inputs and output the RS-232 signals with an inverted sense relative to the input logic levels. The transmitter outputs are protected against infinite short-

circuits to ground without degradation in reliability. The drivers of the SP213EH can be tri-stated by using the SHUTDOWN function.

In the "power-off" state, the output impedance will remain greater than 300 Ω , again satisfying the RS-232 specifications. Should the input of the driver be left open, an internal 400k Ω pull-up resistor to V_{CC} forces the input high, thus committing the output to a low state. The transition of the output from high to low also meets the monotonicity requirements of the standard.

Receivers

The high performance receivers of the SP213EH device can accept input signals at a typical data rate of 500kbps. The receivers convert RS-232 level input signals to inverted TTL level signals. Since the input is usually from a transmission line where long cable lengths and system interference can degrade the signal, the inputs have a typical hysteresis margin of 500mV. This ensures that the receiver is virtually immune to noisy transmission lines. Should an input be left unconnected, a 5k Ω pull-down resistor to ground will commit the output of the receiver to a high state.

Shutdown Mode

The SP213EH features a control input which will disable the device and reduce power supply current to less than 10 μ A, making the parts ideal for battery-powered systems. In the "shutdown" mode, the receivers and transmitters will both be tri-stated. The V+ output of the charge pump will discharge to V_{CC} and the V- output will discharge to ground.

For complete shutdown to occur and the 10 μ A power drain to be realized, the following conditions must be met:

SP213EH:

- 0V must be applied to the \overline{SD} pin
- ENABLE must be either 0V, +5.0V or not connected
- The transmitter inputs must be either +5.0V or not connected
- V_{CC} must be +5V
- Receiver inputs must be >0V and <+5V

ENABLE

The SP213EH features an enable input, which allows the receiver outputs to be either tri-stated or enabled. This can be especially useful when the receiver is tied directly to a shared microprocessor data bus. Enable is active high; that is, +5V applied to the ENABLE pin will enable the receiver outputs.

Wake-Up Function

The SP213EH has a wake-up feature that keeps two receivers (R4 and R5) in an enabled state when the device is in shutdown mode. With only the receivers active during shutdown, the devices draw 5-10µA of supply current.

A typical application of this function would be where a modem is interfaced to a computer in a power-down mode. The ring indicator signal from the modem could be passed

through an active receiver in the SP213EH that is itself in the shutdown mode. The ring indicator signal would propagate through the SP213EH to the power management circuitry of the computer to power up the microprocessor and the SP213EH drivers. After the supply voltage to the SP213EH reaches +5.0V, the SHUTDOWN pin can be disabled, taking the SP213EH out of the shutdown mode.

All receivers that are active during shutdown maintain 500mV (typical) of hysteresis.

Table 5: SP213EH Wake-Up Truth Table

$\overline{\text{SD}}$	EN	Power Up / Down	Receiver Outputs
1	1	Up	Enable
1	0	Up	Tri-state
0	1	Down	Enable
0	0	Down	Tri-state

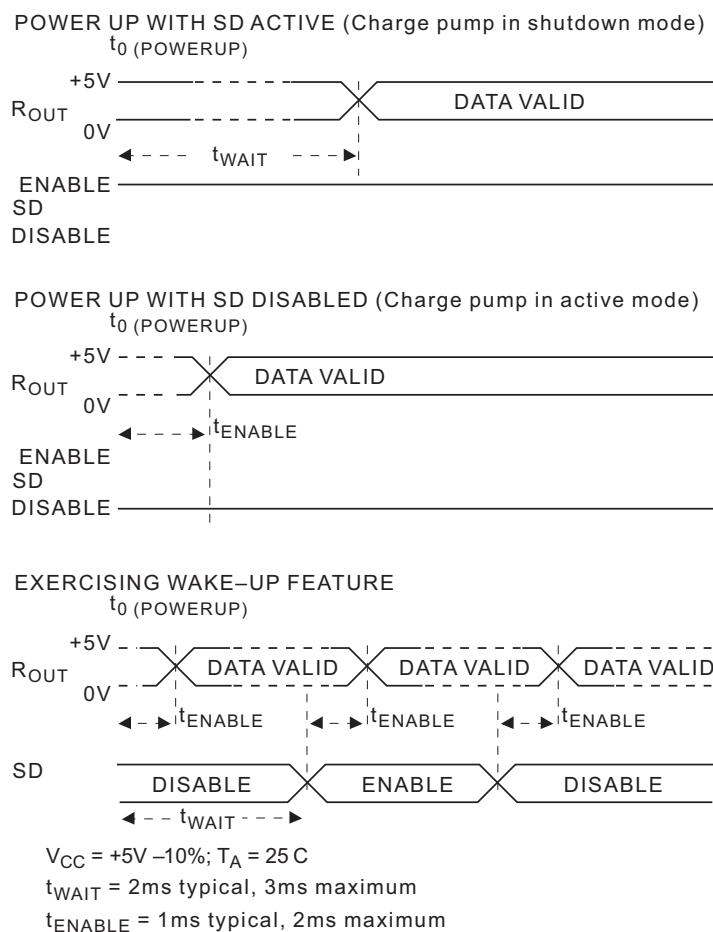

Figure 7: Wake-Up Timing

Charge Pump

The charge pump is a MaxLinear-patented design (5,306,954) and uses a unique approach compared to older less-efficient designs. The charge pumps still requires four external capacitors, but uses a four-phase voltage shifting technique to attain symmetrical 10V power supplies. **Figure 8a** shows the waveform found on the positive side of capacitor C2, and **Figure 8b** shows the negative side of capacitor C2. There is a free-running oscillator that controls the four phases of the voltage shifting. A description of each phase is as follows:

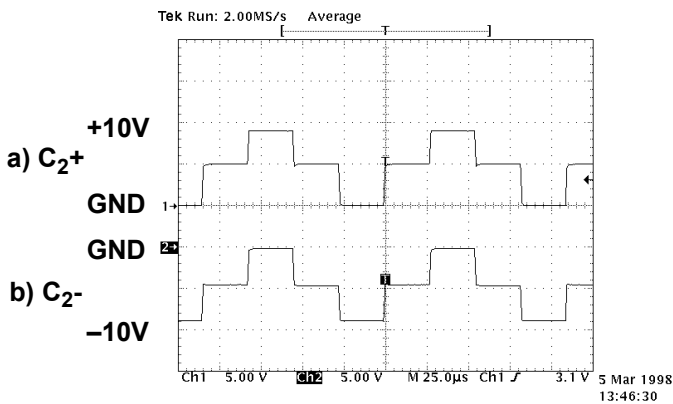

Figure 8: Typical Capacitor C2 Waveform With All Drivers at Maximum Load

Phase 1 - V_{SS} Charge Storage

During this phase of the clock cycle, the positive side of capacitors C₁ and C₂ are initially charged to +5V. C₁₊ is then switched to ground and charge on C₁₋ is transferred to C₂₋. Since C₂₊ is connected to +5V, the voltage potential across capacitor C₂ is now 10V.

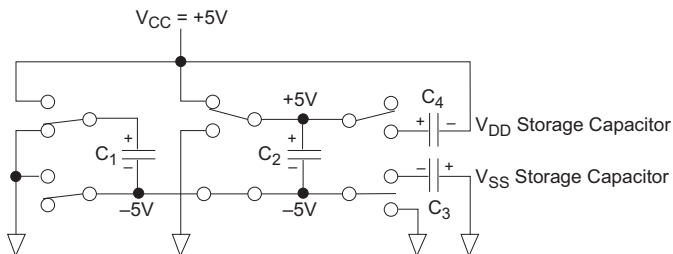

Figure 9: Charge Pump - Phase 1

Phase 2 - V_{SS} Transfer

Phase two of the clock connects the negative terminal of C₂ to the V_{SS} storage capacitor and the positive terminal of C₂ to ground, and transfers the generated -10V to C₃. Simultaneously, the positive side of capacitor C₁ is switched to +5V and the negative side is connected to ground.

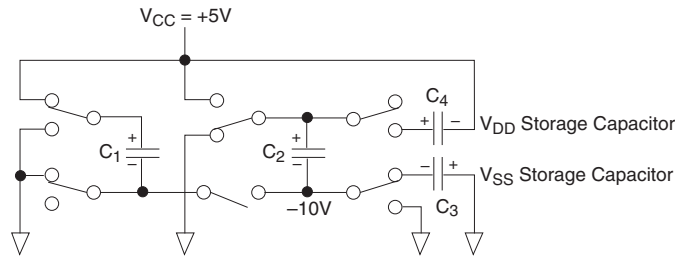

Figure 10: Charge Pump - Phase 2

Phase 3 - V_{DD} Charge Storage

The third phase of the clock is identical to the first phase — the charge transferred in C₁ produces -5V in the negative terminal of C₁, which is applied to the negative side of capacitor C₂. Since C₂₊ is at +5V, the voltage potential across C₂ is 10V.

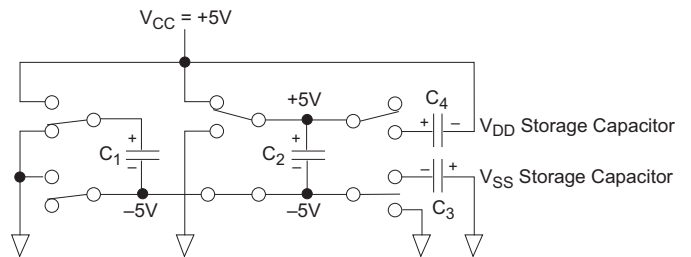

Figure 11: Charge Pump - Phase 3

Phase 4 - V_{DD} Transfer

The fourth phase of the clock connects the negative terminal of C₂ to ground and transfers the generated 10V across C₂ to C₄, the V_{DD} storage capacitor. Again simultaneously with this, the positive side of capacitor C₁ is switched to +5V and the negative side is connected to ground, and the cycle begins again.

Since both V₊ and V₋ are separately generated from V_{CC} in a no-load condition, V₊ and V₋ will be symmetrical. Older charge pump approaches that generate V₋ from V₊

will show a decrease in the magnitude of V_- compared to V_+ due to the inherent inefficiencies in the design.

The clock rate for the charge pump typically operates at 15kHz. The external capacitors must be a minimum of $0.1\mu\text{F}$ with a 16V breakdown rating.

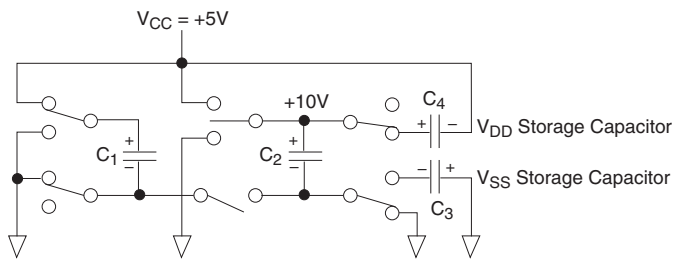

Figure 12: Charge Pump - Phase 4

ESD Tolerance

The SP213EH family incorporates ruggedized ESD cells on all driver output and receiver input pins. The ESD structure is improved over our previous family for more rugged applications and environments sensitive to electro-static discharges and associated transients. The improved ESD tolerance is at least $\pm 15\text{kV}$ without damage nor latch-up.

There are different methods of ESD testing applied:

- a. MIL-STD-883, Method 3015.7
- b. IEC61000-4-2 Air Discharge
- c. IEC61000-4-2 Direct Contact

The Human Body Model has been the generally accepted ESD testing method for semiconductors. This method is also specified in MIL-STD-883, Method 3015.7 for ESD testing. The premise of this ESD test is to simulate the human body's potential to store electro-static energy and discharge it to an integrated circuit. The simulation is performed by using a test model as shown in [Figure 13](#). This method will test the IC's capability to withstand an ESD transient during normal handling such as in manufacturing areas where the ICs tend to be handled frequently.

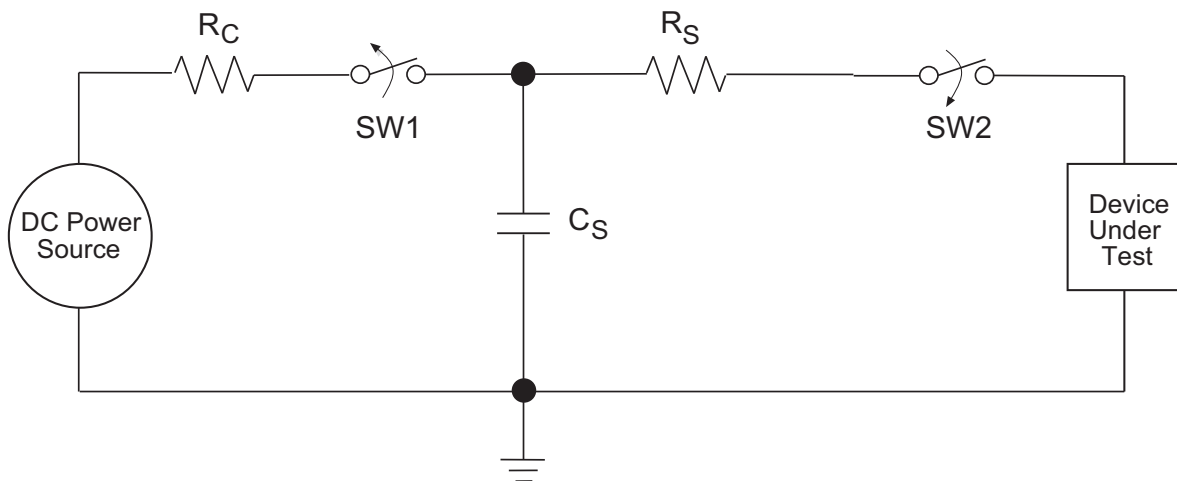

Figure 13: ESD Test Circuit for Human Body Model

The IEC-61000-4-2, formerly IEC801-2, is generally used for testing ESD on equipment and systems. System manufacturers must guarantee a certain amount of ESD protection since the system itself is exposed to the outside environment and human presence. The premise with IEC61000-4-2 is that the system is required to withstand an amount of static electricity when ESD is applied to points and surfaces of the equipment that are accessible to

personnel during normal usage. The transceiver IC receives most of the ESD current when the ESD source is applied to the connector pins. The test circuit for IEC61000-4-2 is shown on [Figure 14](#). There are two methods within IEC61000-4-2, the Air Discharge method and the Contact Discharge method.

With the Air Discharge method, an ESD voltage is applied to the equipment under test (EUT) through air. This simulates an electrically charged person ready to connect a cable onto the rear of the system only to find an unpleasant zap just before the person touches the back panel. The high energy potential on the person discharges through an arcing path to the rear panel of the system before he or she even touches the system. This energy, whether discharged directly or through air, is predominantly a function of the discharge current rather than the discharge voltage. Variables with an air discharge such as approach speed of the object carrying the ESD potential to the system and humidity will tend to change the discharge current. For

example, the rise time of the discharge current varies with the approach speed.

The Contact Discharge Method applies the ESD current directly to the EUT. This method was devised to reduce the unpredictability of the ESD arc. The discharge current rise time is constant since the energy is directly transferred without the air-gap arc. In situations such as hand held systems, the ESD charge can be directly discharged to the equipment from a person already holding the equipment. The current is transferred on to the keypad or the serial port of the equipment directly and then travels through the PCB and finally to the IC.

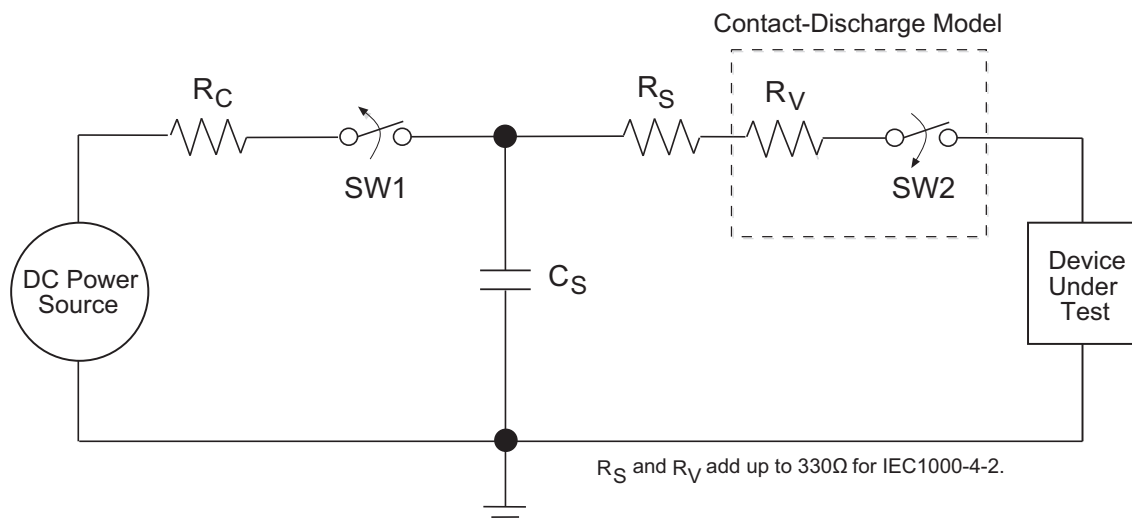

Figure 14: ESD Test Circuit for IEC61000-4-2

The circuit model in Figure 13 and Figure 14 represent the typical ESD testing circuit used for all three methods. The C_S is initially charged with the DC power supply when the first switch (SW1) is on. Now that the capacitor is charged, the second switch (SW2) is on while SW1 switches off. The voltage stored in the capacitor is then applied through R_S , the current limiting resistor, onto the device under test (DUT). In ESD tests, the SW2 switch is pulsed so that the device under test receives a duration of voltage.

For the Human Body Model, the current limiting resistor (R_S) and the source capacitor (C_S) are 1.5k Ω and 100pF, respectively. For IEC61000-4-2, the current limiting resistor (R_S) and the source capacitor (C_S) are 330 Ω and 150pF, respectively.

The higher C_S value and lower R_S value in the IEC61000-4-2 model are more stringent than the Human Body Model. The larger storage capacitor injects a higher voltage to the test point when SW2 is switched on. The

lower current limiting resistor increases the current charge onto the test point.

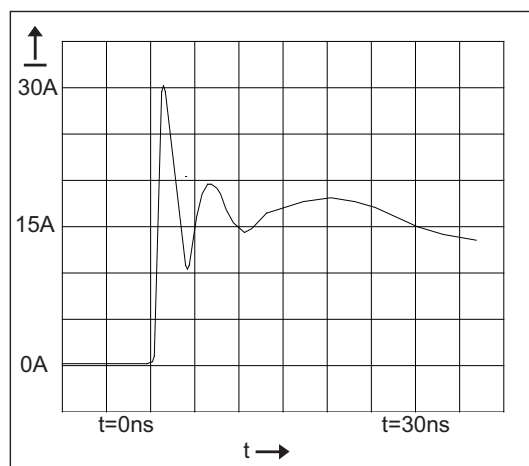

Figure 15: ESD Test Waveform for IEC61000-4-2

EIA Standards

The Electronic Industry Association (EIA) developed several standards of data transmission which are revised and updated in order to meet the requirements of the industry. In data processing, there are two basic means of communicating between systems and components. The RS-232 standard was first introduced in 1962 and, since that time, has become an industry standard. The RS-232 is a relatively slow data exchange protocol, with a maximum baud rate of only 20kbps, which can be transmitted over a maximum copper wire cable length of 50 feet. The SP213EH series of data communications interface

products have been designed to meet both the EIA protocol standards, and the needs of the industry.

Table 6: Transceiver ESD Tolerance Levels

Device Pin Tested	Human Body Model	IEC61000-4-2		
		Air Discharge	Direct Contact	Level
Driver Outputs	±15kV	±15kV	±8kV	4
Receiver Inputs	±15kV	±15kV	±8kV	4

Typical Application Circuit

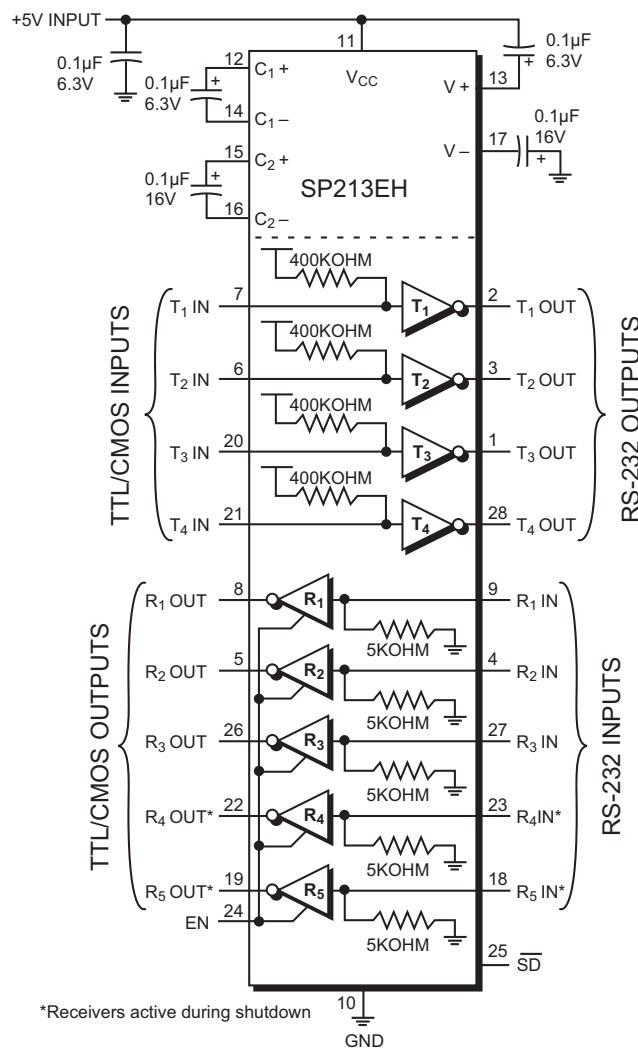
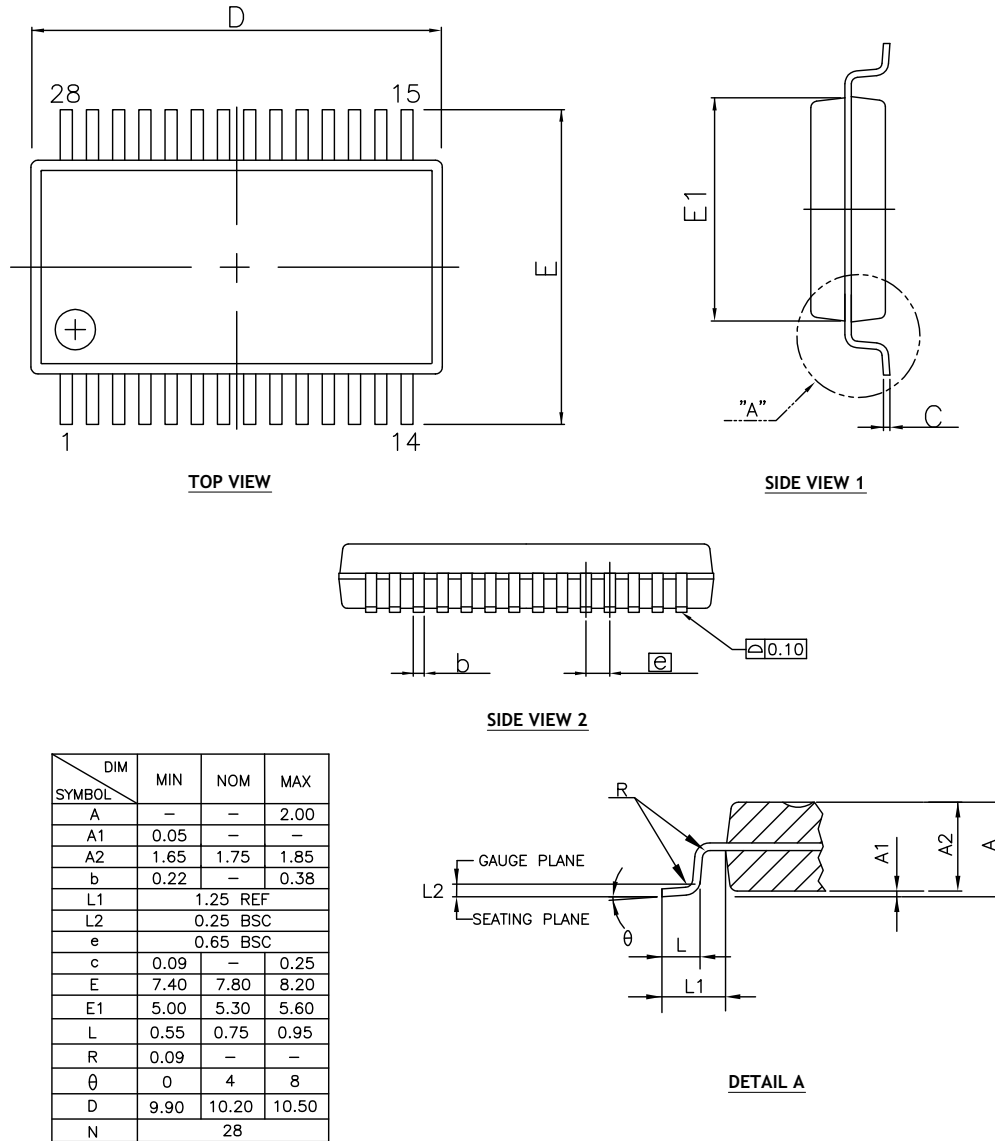

Figure 16: Typical SP213EH Application

Mechanical Dimensions

SSOP28



TERMINAL DETAILS

- ALL DIMENSIONS ARE IN MILLIMETERS, ANGLES ARE IN DEGREES.
- DIMENSIONS AND TOLERANCE PER JEDEC MO-150 AH.

Drawing No.: POD-000000 133

Revision: A

Figure 17: Mechanical Dimensions, SSOP28

Recommended Land Pattern and Stencil

SSOP28

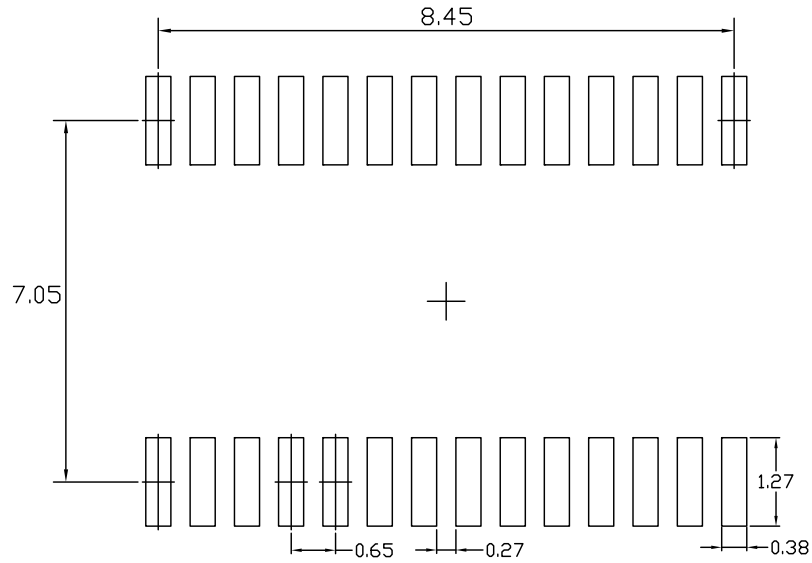

TYPICAL RECOMMENDED LAND PATTERN

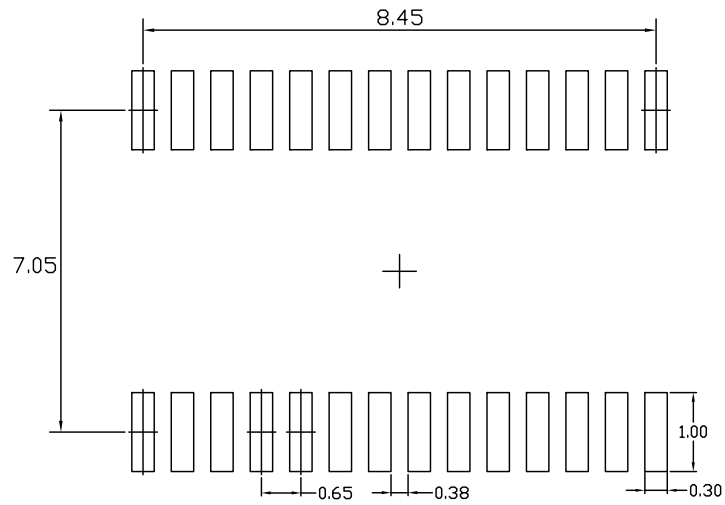

TYPICAL RECOMMENDED STENCIL

Drawing No.: POD-000000 133

Revision: A

Figure 18: Recommended Land Pattern and Stencil, SSOP28

Ordering Information

Table 7: Ordering Information⁽¹⁾

Ordering Part Number	Operating Temperature Range	Package	Lead-Free ⁽²⁾	Packaging Method
SP213EHCA-L/TR	0°C to 70°C	SSOP28	Yes	Reel
SP213EHEA-L/TR	-40°C to 85°C	SSOP28	Yes	Reel

1. Refer to www.maxlinear.com/SP213EH, for most up-to-date Ordering Information.

2. Visit www.maxlinear.com for additional information on Environmental Rating.



MaxLinear, Inc.
5966 La Place Court, Suite 100
Carlsbad, CA 92008
760.692.0711 p.
760.444.8598 f.
www.maxlinear.com

The content of this document is furnished for informational use only, is subject to change without notice, and should not be construed as a commitment by MaxLinear, Inc. MaxLinear, Inc. assumes no responsibility or liability for any errors or inaccuracies that may appear in the informational content contained in this guide. Complying with all applicable copyright laws is the responsibility of the user. Without limiting the rights under copyright, no part of this document may be reproduced into, stored in, or introduced into a retrieval system, or transmitted in any form or by any means (electronic, mechanical, photocopying, recording, or otherwise), or for any purpose, without the express written permission of MaxLinear, Inc.

MaxLinear, Inc. does not recommend the use of any of its products in life support applications where the failure or malfunction of the product can reasonably be expected to cause failure of the life support system or to significantly affect its safety or effectiveness. Products are not authorized for use in such applications unless MaxLinear, Inc. receives, in writing, assurances to its satisfaction that: (a) the risk of injury or damage has been minimized; (b) the user assumes all such risks; (c) potential liability of MaxLinear, Inc. is adequately protected under the circumstances.

MaxLinear, Inc. may have patents, patent applications, trademarks, copyrights, or other intellectual property rights covering subject matter in this document. Except as expressly provided in any written license agreement from MaxLinear, Inc., the furnishing of this document does not give you any license to these patents, trademarks, copyrights, or other intellectual property.

MaxLinear, the MaxLinear logo, and any MaxLinear trademarks, MxL, Full-Spectrum Capture, FSC, G.now, AirPHY, Puma, AnyWAN and the MaxLinear logo are all on the products sold, are all trademarks of MaxLinear, Inc. or one of MaxLinear's subsidiaries in the U.S.A. and other countries. All rights reserved. Other company trademarks and product names appearing herein are the property of their respective owners.

Looking for pricing, stock, or lifecycle information?

Click below to explore more details on WIN SOURCE:

 [View SP211EHEA-L on WIN SOURCE](#)

 [MaxLinear Inc Information](#)

Optimize Your Supply Chain with WIN SOURCE Solutions

-  Global Sourcing Solution
-  Obsolete Management
-  Cost Control Management
-  Shortage Management
-  Alternative Solution
-  Excess Inventory Management