



**THE DATASHEET OF
LTC4263CDE#TRPBF**



Smart High-Side Power Switch for Industrial Applications

One channel: 1 x 1 Ω

Features

- Current controlled input
- Short circuit protection
- Current limitation
- Overload protection
- Overvoltage protection (including load dump)
- Switching inductive loads
- Clamp of negative voltage at output with inductive loads
- Thermal shutdown with restart
- ESD – Protection
- Loss of GND and loss of V_{bb} protection
- Very low standby current
- Reverse battery protection
- Improved electromagnetic compatibility (EMC)

Product Summary

Overvoltage protection	$V_{bbin(AZ)}$	62	V
Operating voltage	$V_{bb(on)}$	4,9...60	V
On-state resistance	R_{ON}	1	Ω
Operating Temperature	T_a	-30 ... +85	$^{\circ}\text{C}$

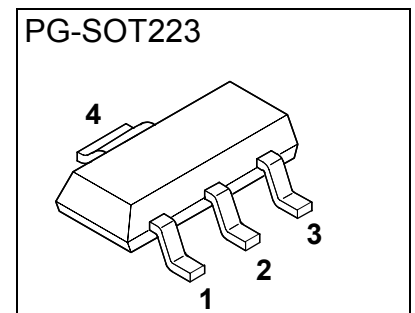

Application

- All types of resistive, inductive and capacitive loads in industrial applications
- Current controlled power switch for 12V, 24V and 42V DC industrial applications
- Driver for electromagnetic relays
- Signal amplifier

General Description

- N channel vertical power MOSFET with charge pump and current controlled input, monolithically integrated in Smart SIPMOS[®] technology.
- Providing embedded protection functions.

Type	Ordering code	Package
ITS 4140N	SP000240073	PG-SOT223

Block Diagram

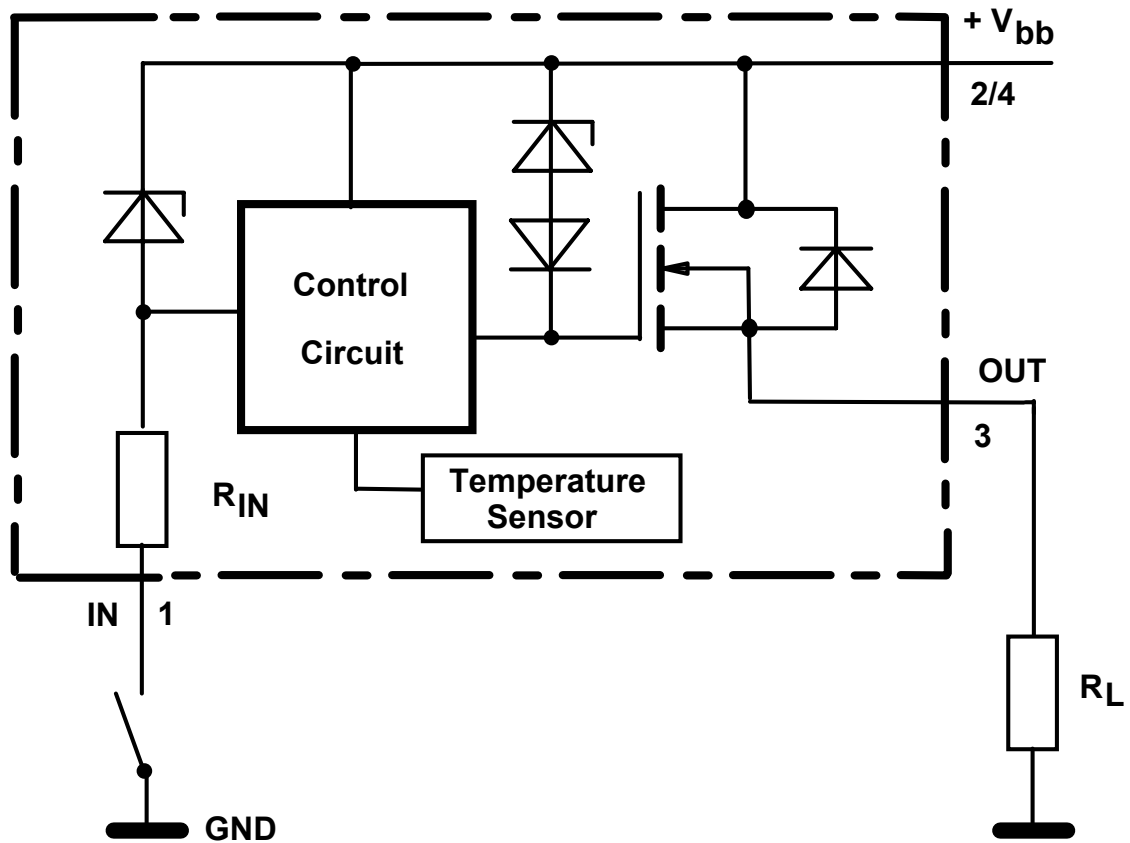

Pin	Symbol	Function
1	IN	Input, activates the power switch in case of connection to GND
2	Vbb	Positive power supply voltage
3	OUT	Output to the load
4	Vbb	Positive power supply voltage

Maximum Ratings

Parameter at $T_j = 25^\circ\text{C}$ unless otherwise specified	Symbol	Values	Unit
Supply voltage	V_{bb}	60	V
Load current (Short – circuit current, see page 5)	I_L	self limited	A
Maximum current through the input pin (DC)	I_{IN}	± 15	mA
Junction temperature	T_j	+150	$^\circ\text{C}$
Operating temperature range	T_a	-30 ... +85	
Storage temperature range	T_{stg}	-40 ... +105	
Power dissipation ¹⁾ $T_a = 25^\circ\text{C}$	P_{tot}	1.7	W
Inductive load switch-off energy dissipation ²⁾ Single pulse $T_j = 150^\circ\text{C}$, $I_L = 0.15\text{A}$	E_{AS}	1	J
Load dump protection ³⁾ $V_{LoadDump}^{4)} = V_A + V_S$ $R_L = 2\Omega$, $t_d = 400\text{ms}$, $V_{IN} = \text{low or high}$ $I_L = 150\text{mA}$, $V_{bb} = 13.5\text{V}$ $V_{bb} = 27\text{V}$	$V_{LoadDump}$	93.5 127	V
Electrostatic discharge voltage (Human Body Model) According to ANSI EOS/ESD – S5.1 – 1993 ESD STM5.1 – 1998 Input pin all other pins	V_{ESD}	± 1 ± 5	kV

¹⁾ Device on 50mm*50mm*1.5mm epoxy PCB FR4 with 6 cm² (one layer, 70 μm thick) copper area for V_{bb} connection. PCB is vertical without blown air.

²⁾ Not subject to production test, specified by design

³⁾ More details see EMC-Characteristics on page 7

⁴⁾ $V_{LoadDump}$ is setup without the DUT connected to the generator per ISO 7637-1 and DIN 40839.

Electrical Characteristics

Parameter	Symbol	Values			Unit
		min.	typ.	max.	
at $T_j = -40 \dots 150 \text{ }^\circ\text{C}$, $V_{bb} = 9 \dots 42 \text{ V}$ unless otherwise specified					

Thermal Characteristics

Thermal resistance @ min. footprint	$R_{th(JA)}$	-	86	125	K/W
Thermal resistance @ 6 cm ² cooling area ¹⁾	$R_{th(JA)}$	-	60	72	
Thermal resistance, junction - soldering point	$R_{th(JS)}$	-	-	17	K/W

Load Switching Capabilities and Characteristics

On-state resistance Pin1 connected to GND $T_j = 25 \text{ }^\circ\text{C}$, $I_L = 150 \text{ mA}$, $V_{bb} = 9 \dots 52 \text{ V}$ $T_j = 150 \text{ }^\circ\text{C}$ $T_j = 25 \text{ }^\circ\text{C}$, $I_L = 50 \text{ mA}$, $V_{bb} = 6 \text{ V}$	R_{ON}				Ω
Nominal load current ²⁾ Device on PCB ¹⁾ $T_a = 85 \text{ }^\circ\text{C}$, $T_j \leq 150 \text{ }^\circ\text{C}$	$I_{L(nom)}$	0.2	-	-	A
Turn-on time ³⁾ $V_{IN} = V_{bb}$ to 0V to 90% V_{OUT} $R_L = 270 \text{ } \Omega$ $R_L = 270 \text{ } \Omega$, $V_{bb} = 13.5 \text{ V}$, $T_j = 25 \text{ }^\circ\text{C}$	t_{on}	-	-	125 ⁴⁾ 100	μs
Turn-off time ³⁾ $V_{IN} = 0\text{V}$ to V_{bb} to 10% V_{OUT} $R_L = 270 \text{ } \Omega$ $R_L = 270 \text{ } \Omega$, $V_{bb} = 13.5 \text{ V}$, $T_j = 25 \text{ }^\circ\text{C}$	t_{off}	-	-	175 ⁴⁾ 140	μs
Slew rate on ³⁾ $V_{IN} = V_{bb}$ to 0V 10 to 30% V_{OUT} $R_L = 270 \text{ } \Omega$ $R_L = 270 \text{ } \Omega$, $T_j = 25 \text{ }^\circ\text{C}$, $V_{bb} = 13.5 \text{ V}$	dV/dt_{on}	-	-	6 ⁴⁾ 4	V/ μs
Slew rate off ³⁾ $V_{IN} = 0\text{V}$ to V_{bb} 70 to 40% V_{OUT} $R_L = 270 \text{ } \Omega$ $R_L = 270 \text{ } \Omega$, $T_j = 25 \text{ }^\circ\text{C}$, $V_{bb} = 13.5 \text{ V}$	$-dV/dt_{off}$	-	-	8 ⁴⁾ 4	V/ μs

¹⁾Device on 50mm*50mm*1.5mm epoxy PCB FR4 with 6 cm² (one layer, 70 μm thick) copper area for V_{bb} connection. PCB is vertical without blown air.

²⁾Nominal load current is limited by the current limitation (see page 5)

³⁾Timing values only with high input slewrates, otherwise slower.

⁴⁾not subject to production test, specified by design

Electrical Characteristics

Parameter at $T_j = -40...150\text{ °C}$, $V_{bb} = 9...42\text{ V}$ unless otherwise specified	Symbol	Values			Unit
		min.	typ.	max.	

Operating Parameters

Operating voltage	$V_{bb(on)}$	4.9	-	60	V
Standby current Pin1 = open	$I_{bb(off)}$	-	2	10	μA

Protection Functions¹⁾

Initial peak short circuit current limit (see page 14) $T_j = -40\text{ °C}$, $V_{bb} = 13.5\text{ V}$, $t_m = 100\text{ }\mu\text{s}$ $T_j = 25\text{ °C}$ $T_j = 150\text{ °C}$	$I_{L(SCp)}$	-	-	1.2	A
		-	0.9	-	
		0.2	-	-	
Repetitive short circuit current limit $T_j = T_{jt}$	$I_{L(SCr)}$	-	0.7	-	
Output clamp (inductive load switch off) at $V_{OUT} = V_{bb} - V_{ON(CL)}$, $I_{bb} = 4\text{ mA}$	$V_{ON(CL)}$	60	-	-	V
Overvoltage protection $I_{bb} = 1\text{ mA}$	$V_{bbin(AZ)}$	62	68	-	
Thermal overload trip temperature	T_{jt}	150	-	-	
Thermal hysteresis	ΔT_{jt}	-	10	-	K

¹⁾ Integrated protection functions are designed to prevent IC destruction under fault conditions described in the data sheet. Fault conditions are considered as "outside" normal operating range. Protection functions are not designed for continuous repetitive operation.

Electrical Characteristics

Parameter at $T_j = -40...150\text{ }^\circ\text{C}$, $V_{bb} = 9...42\text{ V}$ unless otherwise specified	Symbol	Values			Unit
		min.	typ.	max.	
Input					
Off state input current $V_{OUT} \leq 0.1\text{ V}$ $T_j = 25\text{ }^\circ\text{C}$, $R_L = 270\ \Omega$ $T_j = 150\text{ }^\circ\text{C}$	$I_{IN(off)}$	-	-	0.05	mA
		-	-	0.04	
On state input current (Pin1 grounded) ¹⁾	$I_{IN(on)}$	-	0.3	1	
Input resistance	R_I	0.5	1	2.5	k Ω

Reverse Battery

Continuous reverse drain current $T_C = 25\text{ }^\circ\text{C}$	I_S	-	-	0.2	A
Drain-source diode voltage ($V_{OUT} > V_{bb}$) $I_F = 0.2\text{ A}$, $I_{IN} \leq 0,05\text{ mA}$	$-V_{ON}$	-	600	-	mV

¹⁾Driver circuit must be able to drive currents > 1mA.

Conducted Emission

Acc. IEC 61967-4 (1Ω / 150Ω method)

Typ. V_{bb} -Pin Emission at DC-On with 150Ω-matching network

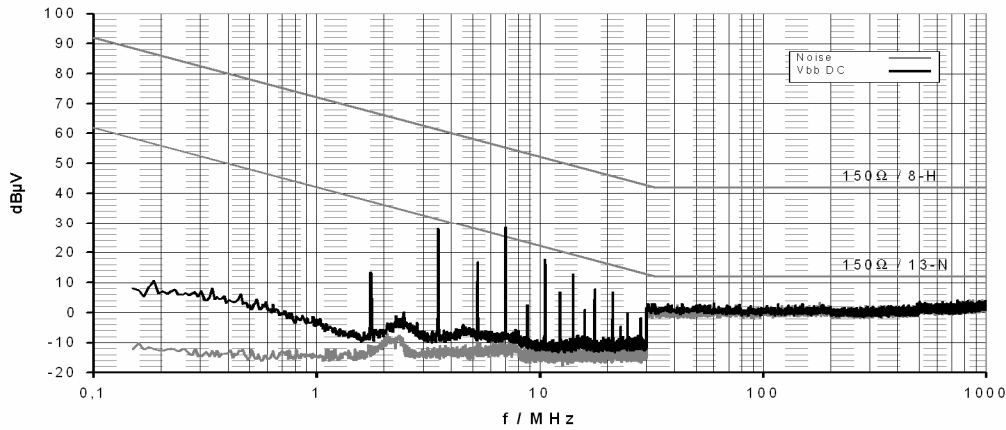

Typ. V_{bb} -Pin Emission at PWM-Mode with 150Ω-matching network

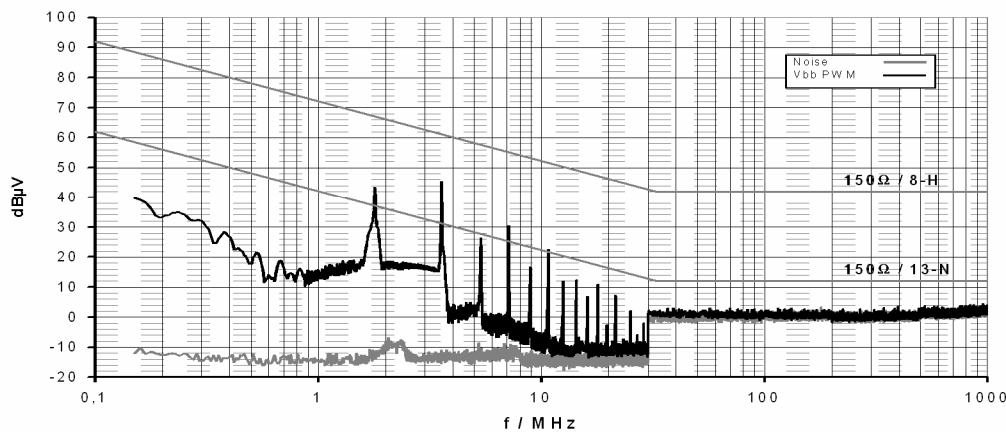

Test circuit:

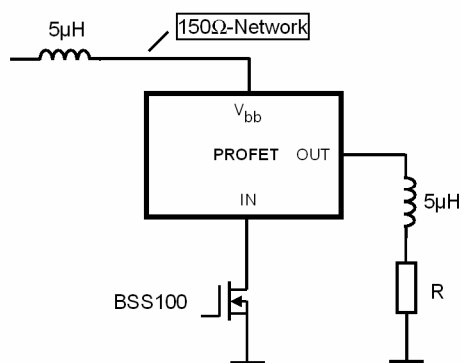

For defined decoupling and high reproducibility a defined choke (5μH at 1 MHz) is inserted between supply and V_{bb} -pin.

Conducted Susceptibility

Acc. 47A/658/CD IEC 62132-4 (Direct Power Injection)

Direct Power Injection: Forward Power CW
Failure criteria: Amplitude and frequency deviation max. 10% at Out

Typ. V_{bb} -Pin Susceptibility at DC-On/Off

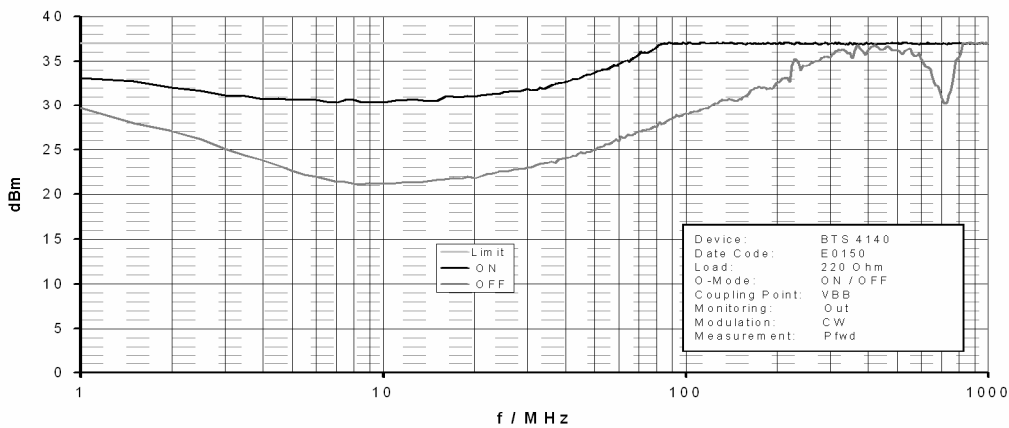

Typ. V_{bb} -Pin Susceptibility at PWM-Mode

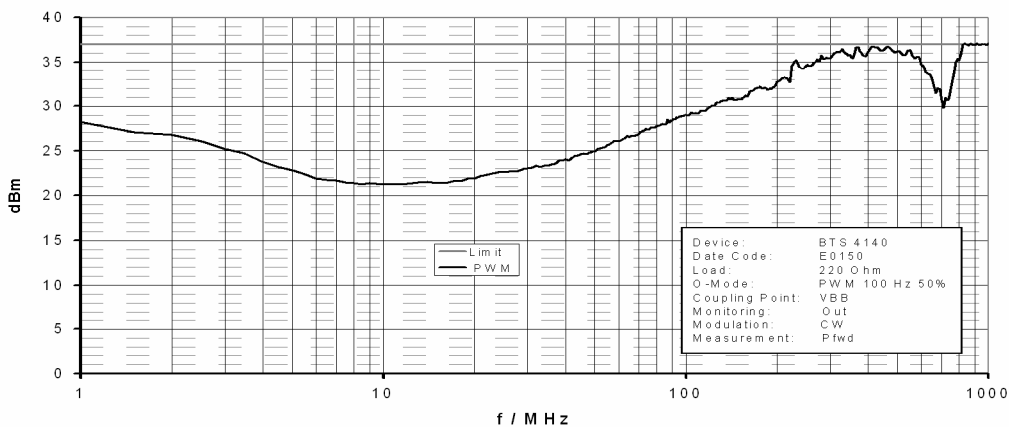

Test circuit:

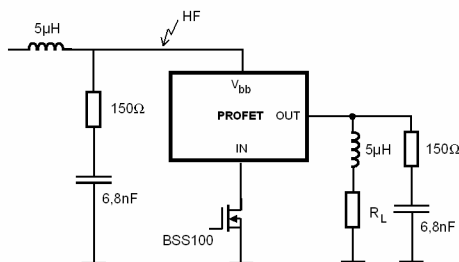

For defined decoupling and high reproducibility the same choke and the same 150Ω -matching network as for the emission measurement is used.

Terms

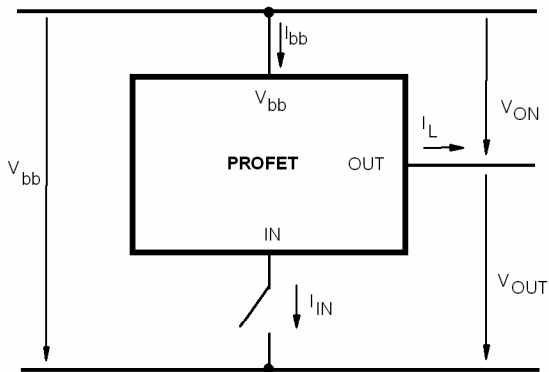

Inductive and overvoltage output clamp

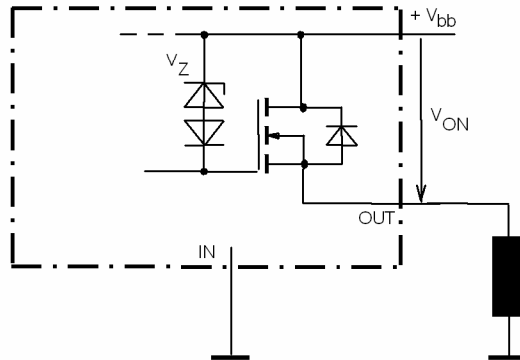

V_{ON} clamped to 60 V min.

Input circuit (ESD protection)

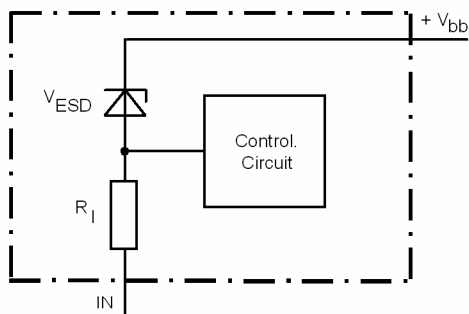

Overvoltage protection of logic part

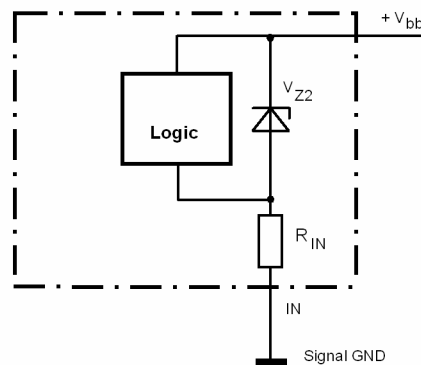

Reverse battery protection

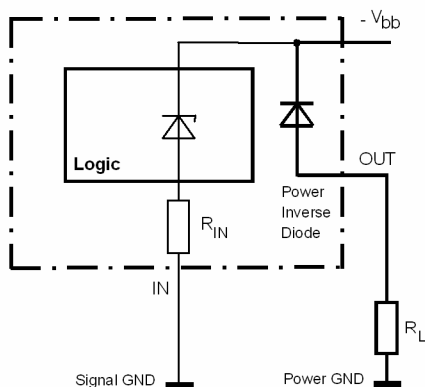

$$V_{bb,AZ} = V_{Z2} + I_{bb} * R_{IN} = 62V \text{ min.}$$

$R_I=1k\Omega$ typ., Temperature protection is not active during inverse current.

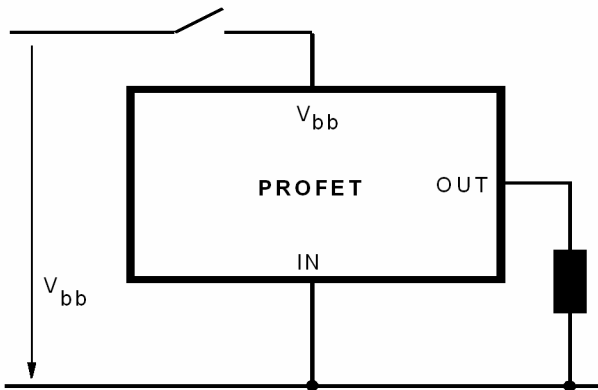
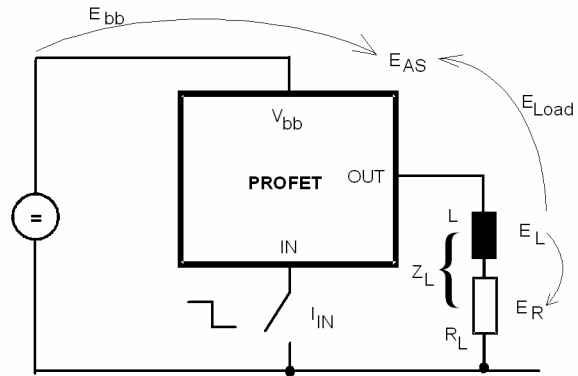
V_{bb} disconnect with charged inductive load

Inductive Load switch-off energy dissipation

Energy stored in load inductance: $E_L = \frac{1}{2} \cdot L \cdot I_L^2$

While demagnetizing load inductance, the energy dissipated in PROFET is

$E_{AS} = E_{bb} + E_L - E_R = V_{ON(CL)} \cdot \int i_L(t) dt$,
with an approximate solution for $R_L > 0\Omega$:

$$E_{AS} = \frac{L}{R_L} \cdot (V_{bb} + |V_{OUT(CL)}|) \cdot \left[\frac{-|V_{OUT(CL)}|}{R_L} \cdot \ln \left(1 + \frac{R_L \cdot I_L}{|V_{OUT(CL)}|} \right) + I_L \right]$$

Typ. transient thermal impedance

$Z_{thJA} = f(t_p)$ @ 6cm² heatsink area

Parameter: $D = t_p / T$

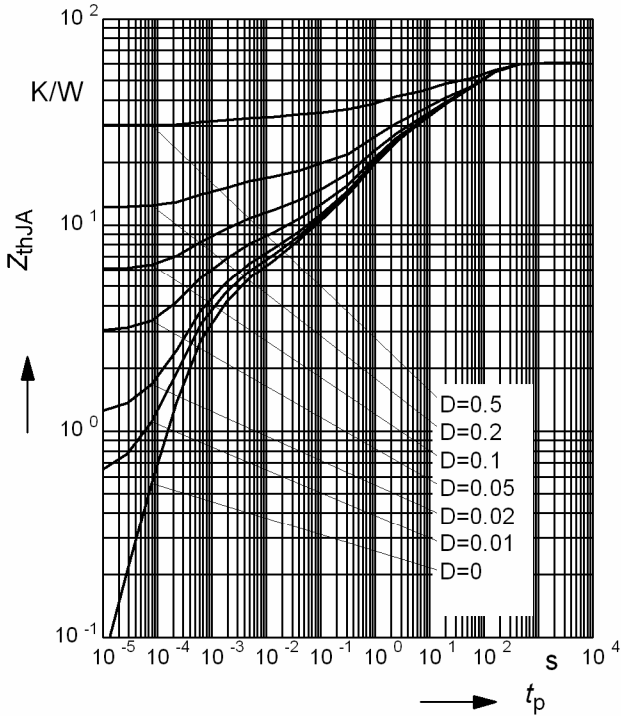

Typ. transient thermal impedance

$Z_{thJA} = f(t_p)$ @ min. footprint

Parameter: $D = t_p / T$

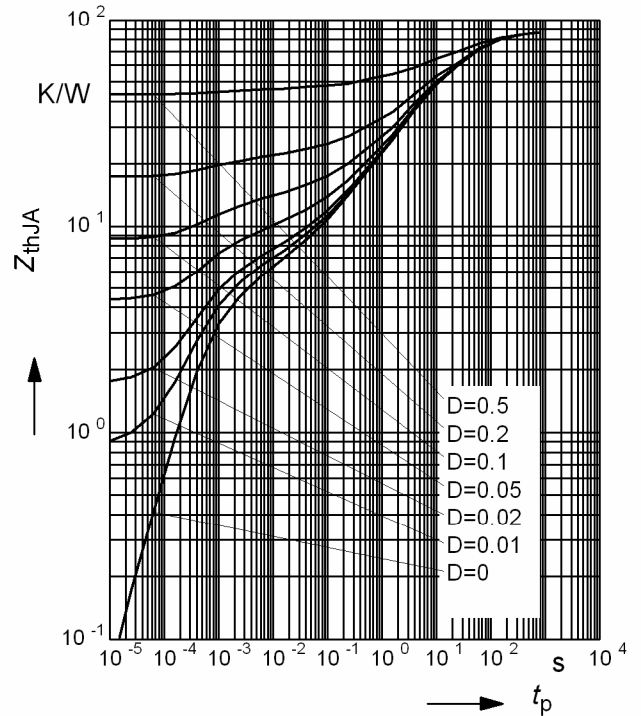

Typ. on-state resistance

$R_{ON} = f(T_j)$; $V_{bb} = 9V$; Pin1 grounded;

$I_L = 150mA$

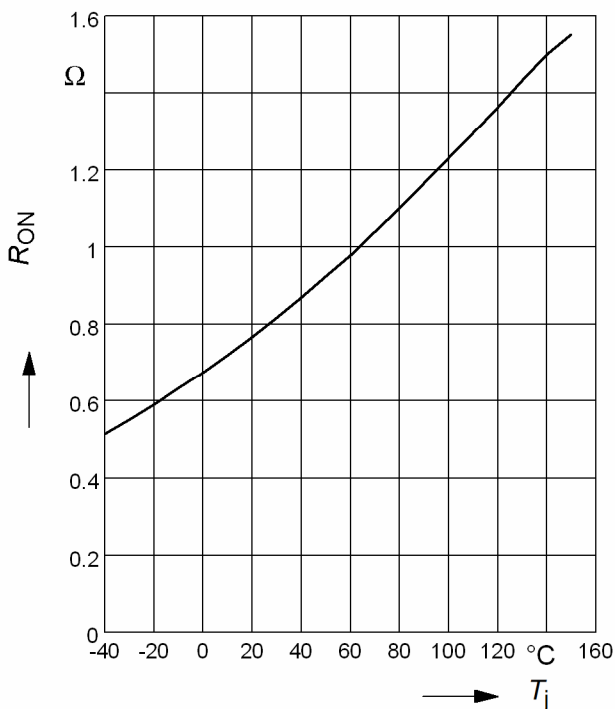

Typ. on-state resistance

$R_{ON} = f(V_{bb})$; $I_L = 150mA$; Pin1 grounded

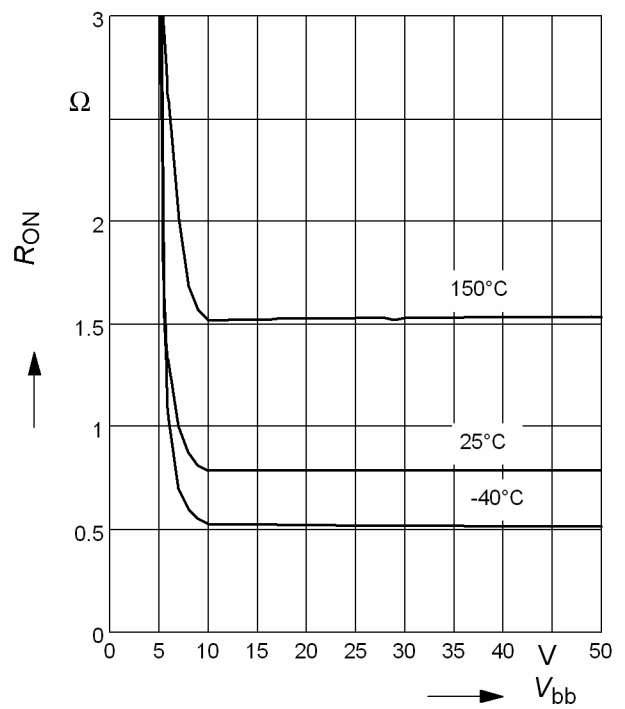

Typ. turn on time

$$t_{on} = f(T_j); R_L = 270\Omega$$

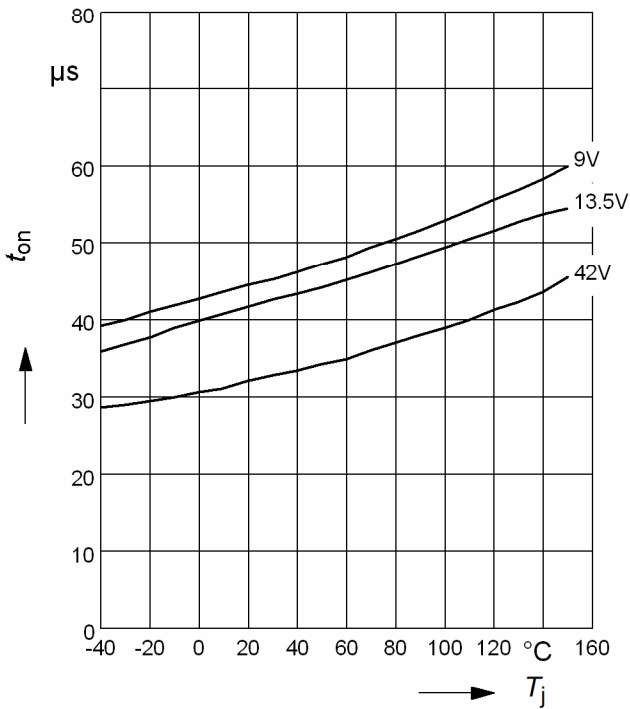
Typ. turn off time

$$t_{off} = f(T_j); R_L = 270\Omega$$

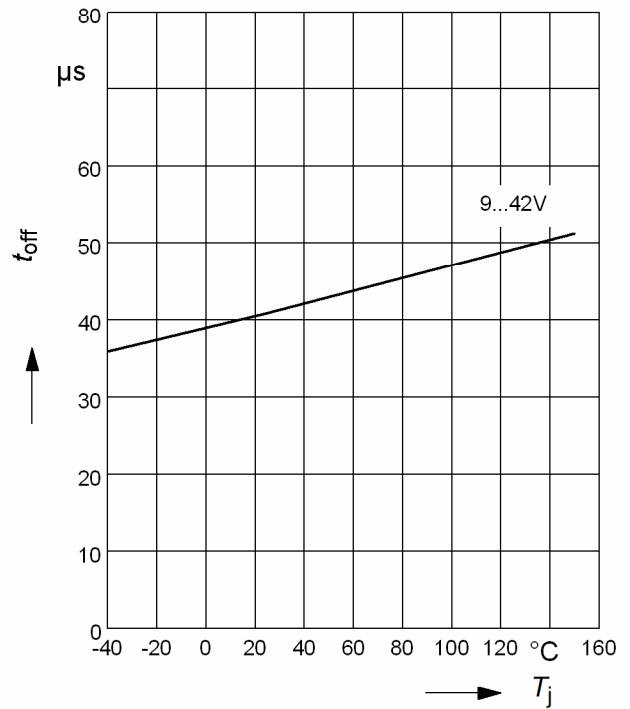
Typ. slew rate on

$$dV/dt_{on} = f(T_j); R_L = 270\Omega$$

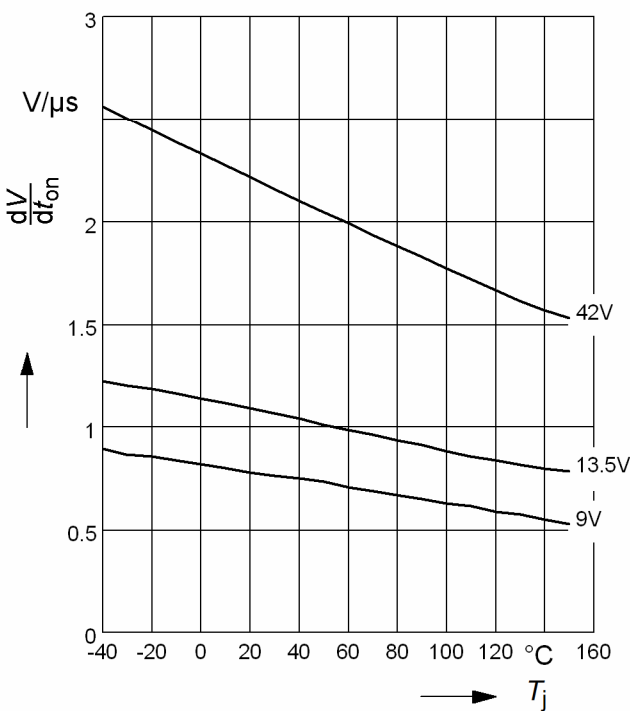

Typ. slew rate off

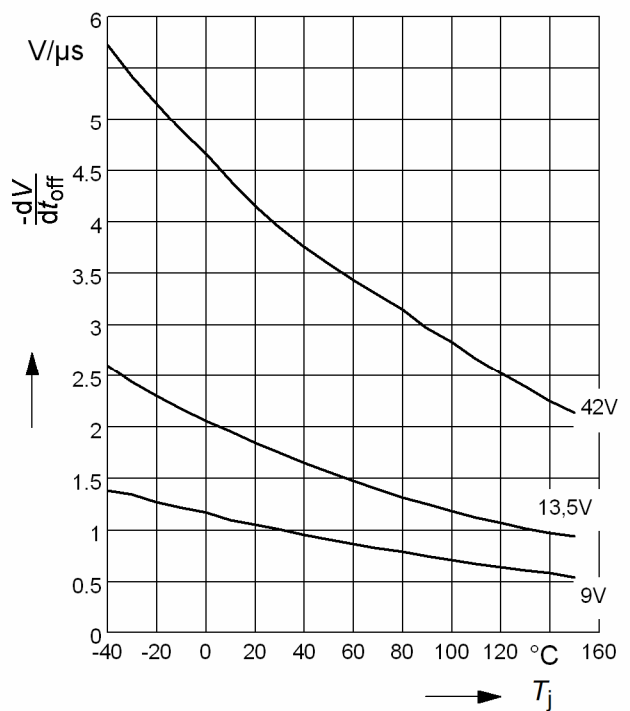
$$-dV/dt_{off} = f(T_j); R_L = 270\Omega$$

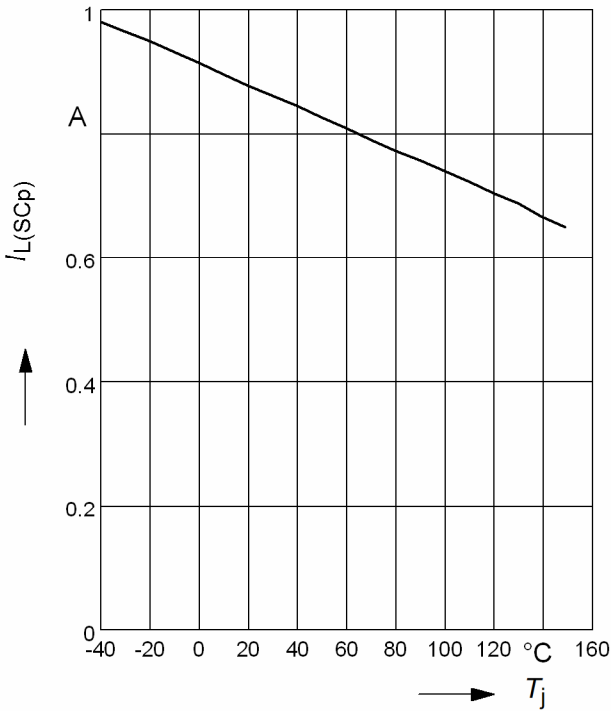

Typ. initial peak short circuit current limit

$$I_{L(SCp)} = f(T_j); V_{bb} = 13,5 \text{ V}; t_m = 100 \mu\text{s}$$



Typ. initial short circuit shutdown time

$$t_{off(SC)} = f(T_{j,start})$$

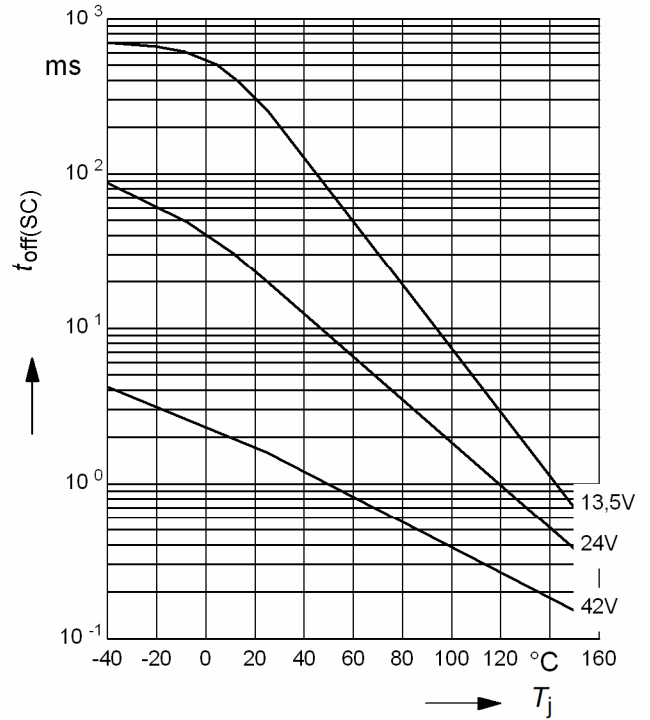

Typ. initial peak short circuit current limit

$$I_{L(SCp)} = f(V_{bb}); t_m = 100 \mu\text{s}$$

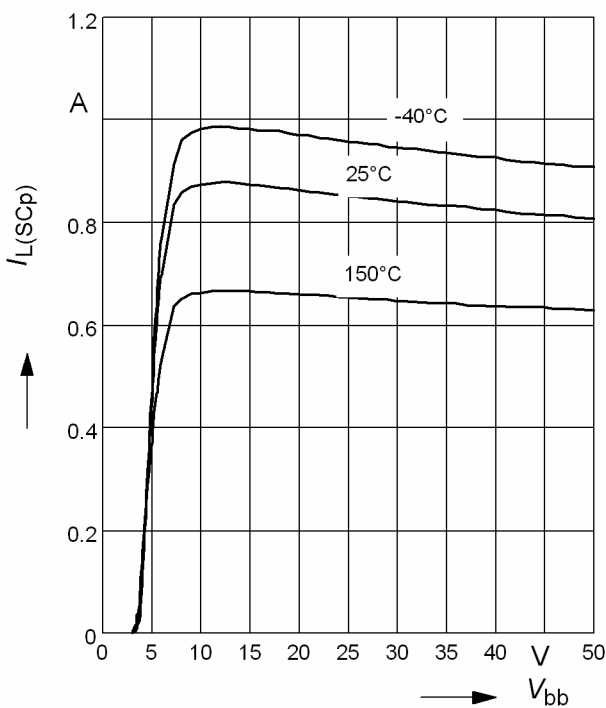

Typ. current limitation characteristic:

$$I_{L(SC)} = f(V_{ON}), V_{bb} = 13,5 \text{ V}$$

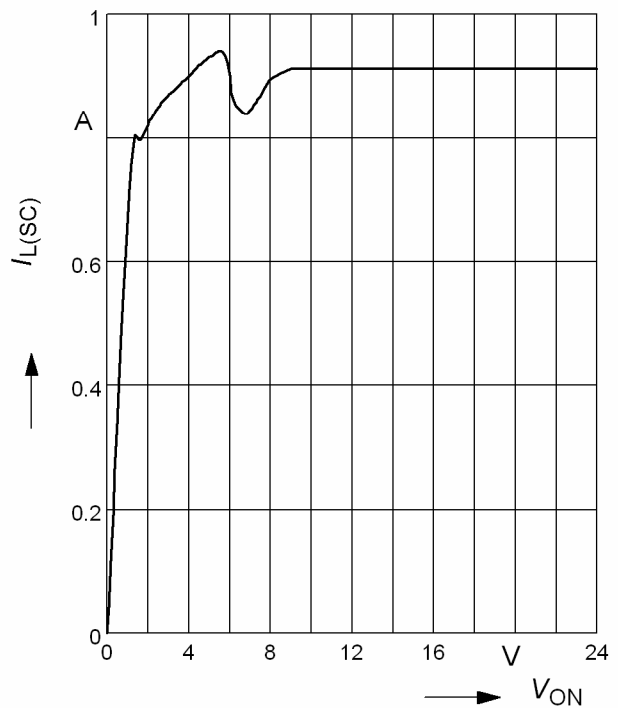

Typ. standby current

$I_{bb(off)} = f(T_j)$; Pin1 open

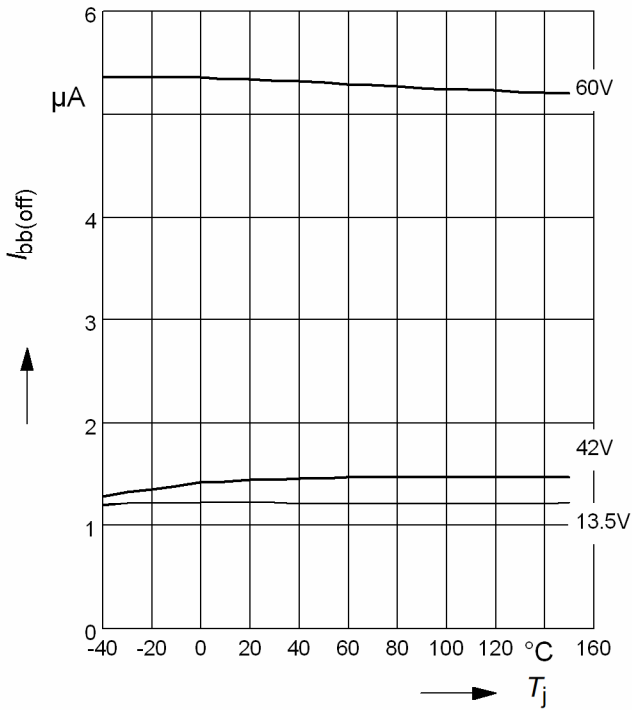

Maximum allowable inductive switch-off energy, single pulse

$E_{AS} = f(I_L)$; $T_{jstart} = 150^{\circ}C$

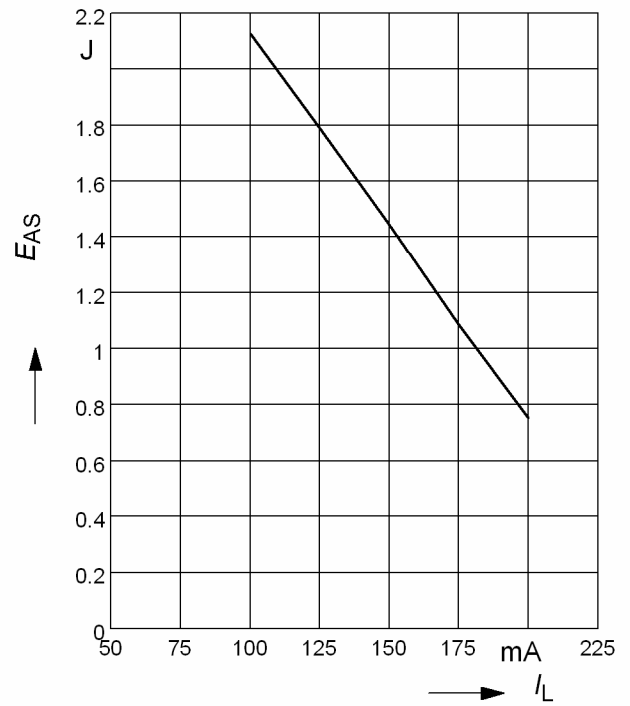

Timing diagrams

Figure 1a: V_{bb} turn on:

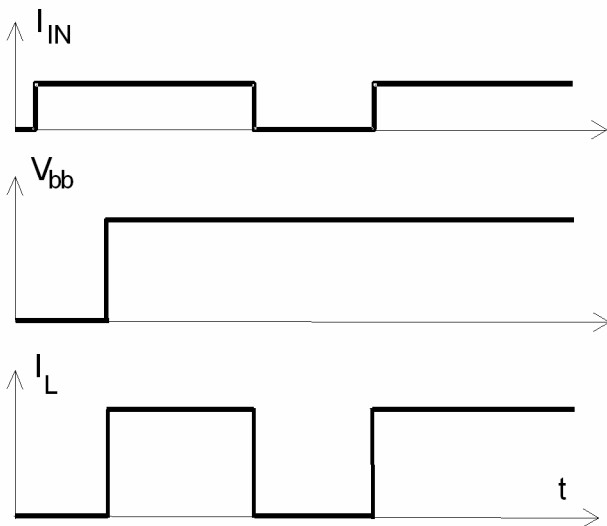

Figure 2b: Switching a lamp

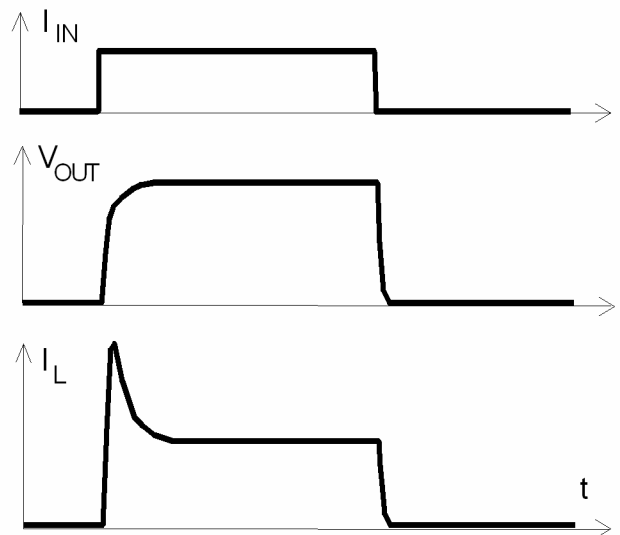

Figure 2a: Switching a resistive load, turn-on/off time and slew rate definition

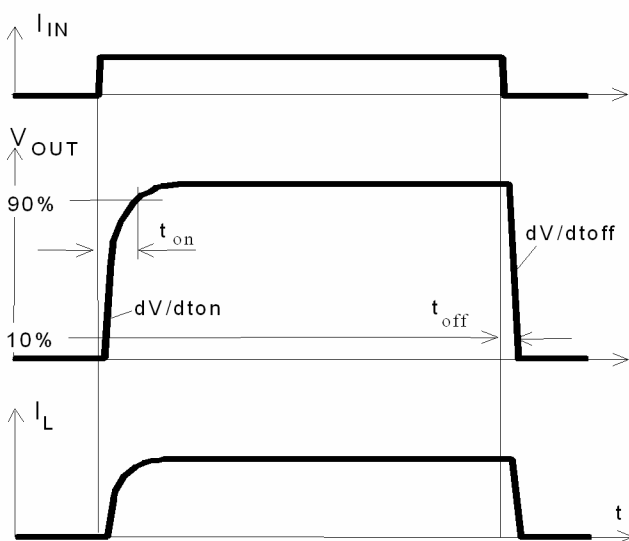

Figure 2c: Switching an inductive load

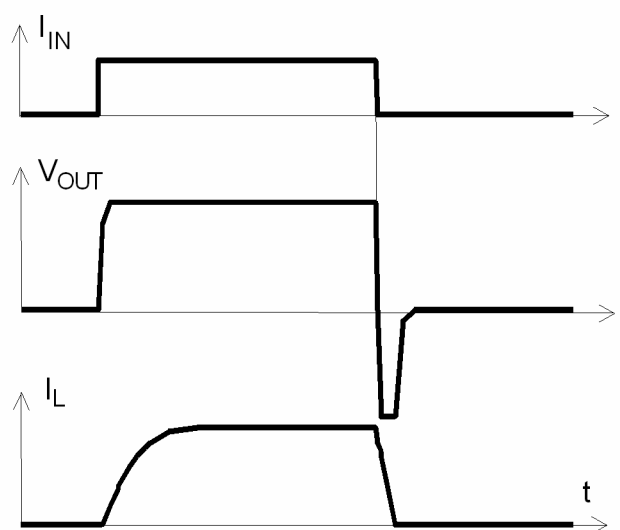
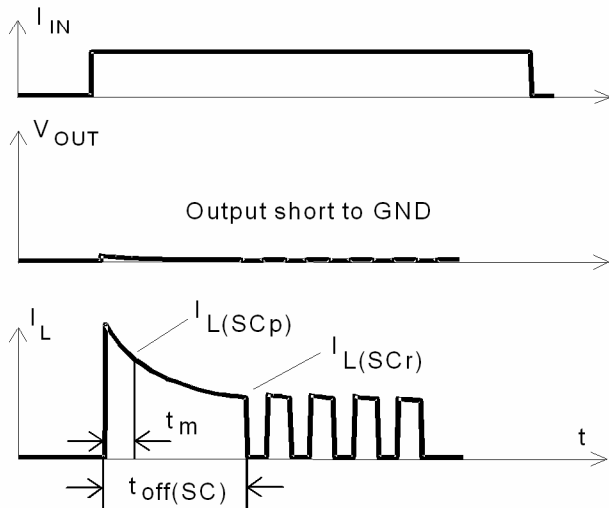

Figure 3a: Turn on into short circuit, shut down by overtemperature, restart by cooling



Heating up of the chip may require several milliseconds, depending on external conditions.

Figure 3b: Short circuit in on-state shut down by overtemperature, restart by cooling

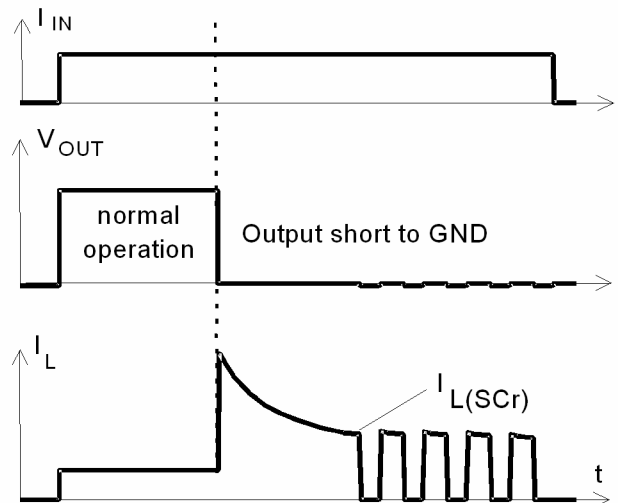
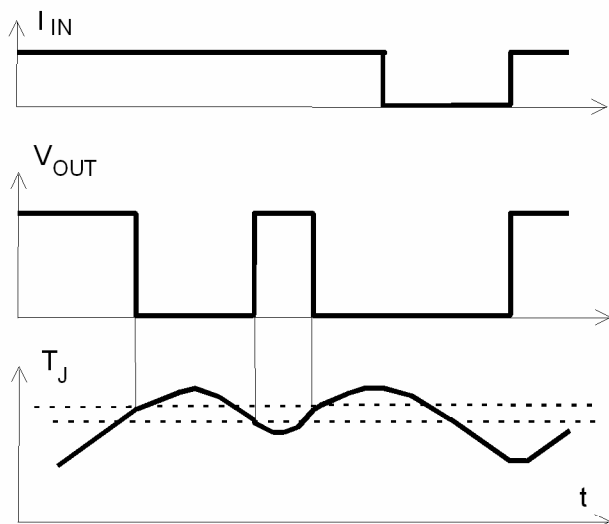

Figure 4: Overtemperature: Reset if $T_j < T_{jt}$



Package and ordering code:

Type	Ordering code	Package
ITS 4140N	SP000240073	PG-SOT223

all dimensions in mm.

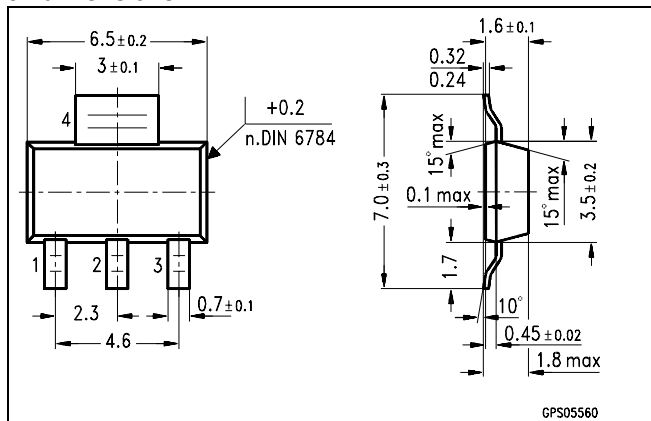
Edition 2006-02-01

Published by
Infineon Technologies AG
 81726 München, Germany

© Infineon Technologies AG 2006.
 All Rights Reserved.

Legal Disclaimer

The information given in this document shall in no event be regarded as a guarantee of conditions or characteristics ("Beschaffenheitsgarantie"). With respect to any examples or hints given herein, any typical values stated herein and/or any information regarding the application of the device, Infineon Technologies hereby disclaims any and all warranties and liabilities of any kind, including without limitation warranties of non-infringement of intellectual property rights of any third party.

Information

For further information on technology, delivery terms and conditions and prices please contact your nearest Infineon Technologies Office (www.infineon.com).



Warnings

Due to technical requirements components may contain dangerous substances. For information on the types in question please contact your nearest Infineon Technologies Office.

Infineon Technologies Components may only be used in life-support devices or systems with the express written approval of Infineon Technologies, if a failure of such components can reasonably be expected to cause the failure of that life-support device or system, or to affect the safety or effectiveness of that device or system. Life support devices or systems are intended to be implanted in the human body, or to support and/or maintain and sustain and/or protect human life. If they fail, it is reasonable to assume that the health of the user or other persons may be endangered.

Looking for pricing, stock, or lifecycle information?

Click below to explore more details on WIN SOURCE:

-  [View LTC4263CDE#TRPBF on WIN SOURCE](#)
-  [Linear Technology Information](#)

Optimize Your Supply Chain with WIN SOURCE Solutions

-  Global Sourcing Solution
-  Obsolete Management
-  Cost Control Management
-  Shortage Management
-  Alternative Solution
-  Excess Inventory Management