



**THE DATASHEET OF
NCP456RFCCT2G**



NCP456R, NCP457

2 A Single Load Switch for Low Voltage Rail

The NCP456R and NCP457 are power load switch with very low Ron NMOSFET controlled by external logic pin, allowing optimization of battery life, and portable device autonomy.

Indeed, thanks to a best in class current consumption optimization with NMOS structure, leakage currents are drastically decreased. Offering optimized leakages isolation on the ICs connected on the battery.

Output discharge path is proposed, in the NCP457 version, to eliminate residual voltages on the external components connected on output pin.

Reverse voltage protection, from OUT to IN is offered in the NCP456R version.

Proposed in wide input voltage range from 0.75 V to 5.5 V, and a very small CSP6 0.85 x 1.25 mm².

Features

- 0.75 V – 5.5 V Operating Range
- 24 mΩ N MOSFET
- Vbias Rail Input
- DC Current up to 2 A
- Output Auto-discharge Option
- Reverse Blocking Option
- Active High EN Pin
- CSP6, 0.85 x 1.25 mm², Pitch 0.4 mm
- These Devices are Pb-Free and are RoHS Compliant

Typical Applications

- Notebooks
- Tablets
- Wireless
- Mobile Phones
- Digital Cameras



ON Semiconductor®

<http://onsemi.com>

MARKING DIAGRAM



WLCSP6, 1.25x0.85
CASE 567GZ

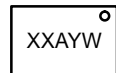

A = Assembly Location
Y = Year
W = Work Week

PIN CONNECTIONS

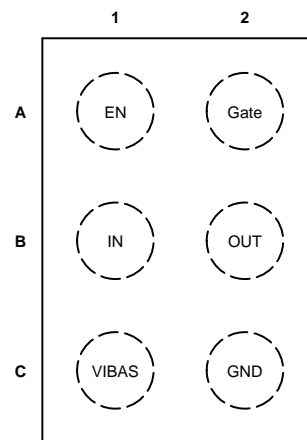

Top View

ORDERING INFORMATION

See detailed ordering, marking and shipping information on page 12 of this data sheet.

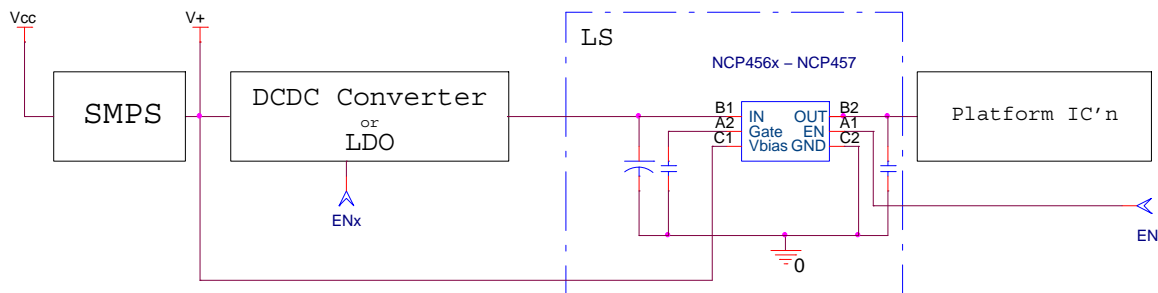

Figure 1. Typical Application Schematic

NCP456R, NCP457

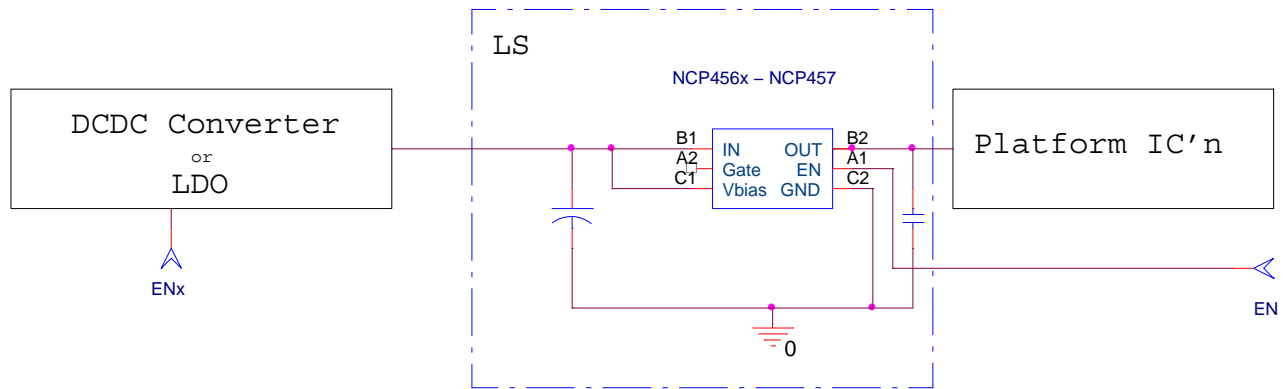

Figure 2. Application Schematic with Vbias Connected to IN and No Gate Delay

PIN FUNCTION DESCRIPTION

Pin Name	Pin Number	Type	Description
EN	A1	INPUT	Enable input, logic high turns on power switch .
IN	B1	POWER	Load-switch input pin.
VBIAS	C1	POWER	External supply voltage input.
GATE	A2	INPUT	OUT pin slew rate control (t_{rise}).
OUT	B2	POWER	Load-switch output pin.
GND	C2	POWER	Ground connection.

NCP456R, NCP457

BLOCK DIAGRAMS

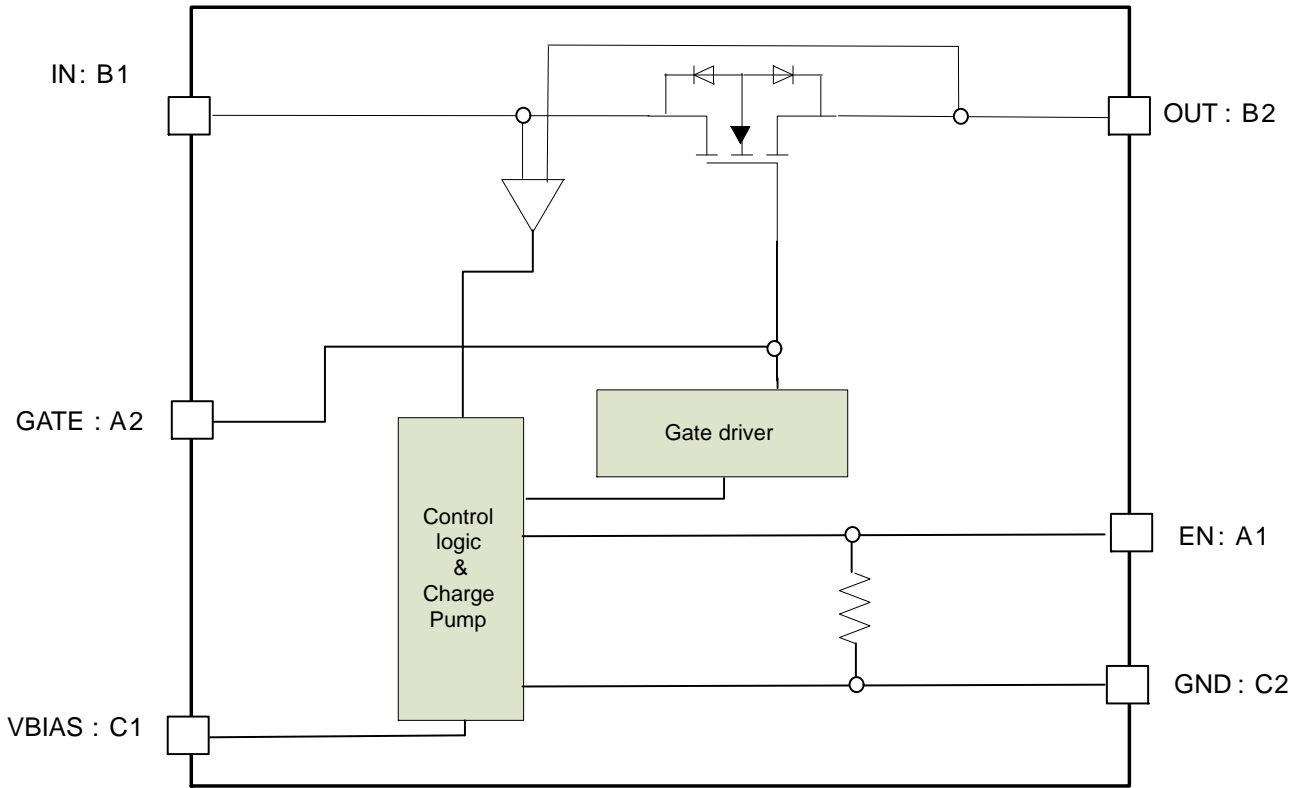

Figure 3. NCP456R Block Diagram – NCP456R Version

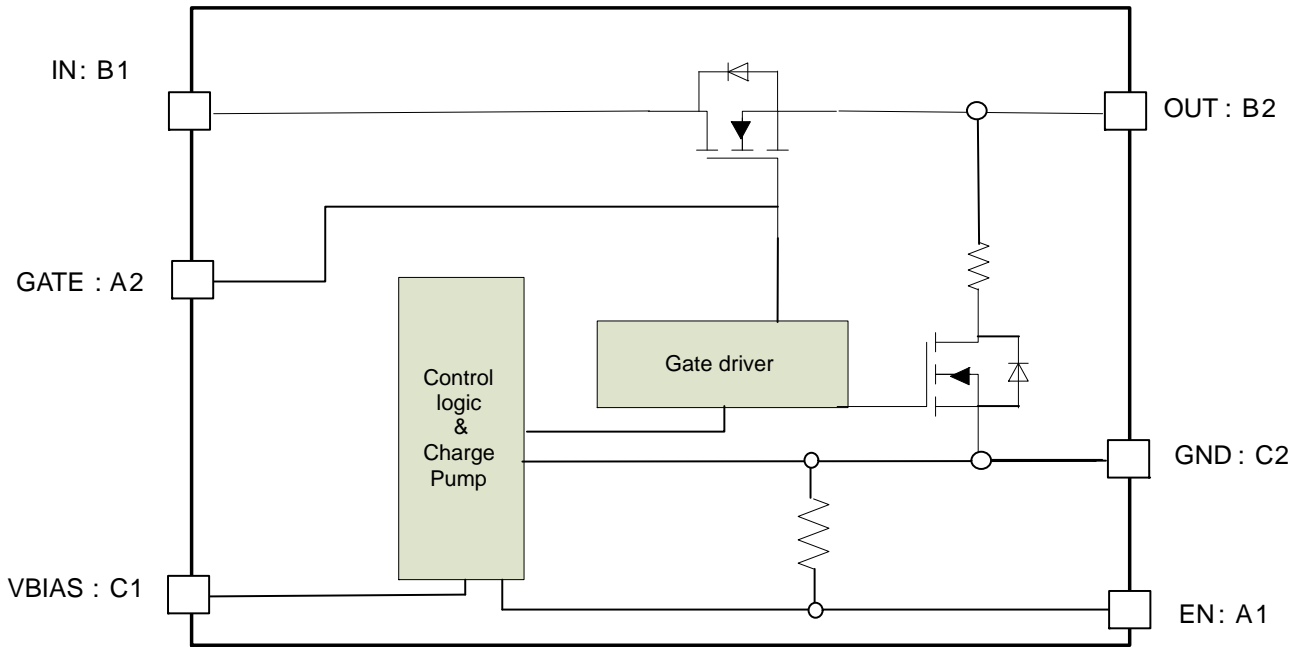

Figure 4. NCP457 Block Diagram – NCP457 Version

NCP456R, NCP457

MAXIMUM RATINGS

Rating	Symbol	Value	Unit
IN, OUT, EN, VBIAS, GATE Pins: (Note 1)	$V_{EN}, V_{IN}, V_{OUT}, V_{BIAS}, V_{GATE}$	-0.3 to + 6.5	V
From IN to OUT Pins: Input/Output (Note 1) NCP457	V_{IN}, V_{OUT}	0 to + 6.5	V
From IN to OUT Pins: Input/Output (Note 1) NCP456R	V_{IN}, V_{OUT}	±6.5	V
Human Body Model (HBM) ESD Rating are (Note 2)	ESD HBM	2000	V
Machine Model (MM) ESD Rating are (Note 2)	ESD MM	200	V
Latch-up Protection (Note 3) Pins IN, OUT, EN, VBIAS and GATE	LU	100	mA
Maximum Junction Temperature	T_J	-40 to + 125	°C
Storage Temperature Range	T_{STG}	-40 to + 150	°C
Moisture Sensitivity (Note 4)	MSL	Level 1	

Stresses exceeding those listed in the Maximum Ratings table may damage the device. If any of these limits are exceeded, device functionality should not be assumed, damage may occur and reliability may be affected.

1. According to JEDEC standard JESD22-A108.
2. This device series contains ESD protection and passes the following tests:
Human Body Model (HBM) ±2.0 kV per JEDEC standard: JESD22-A114 for all pins.
Machine Model (MM) ±250 V per JEDEC standard: JESD22-A115 for all pins.
3. Latch up Current Maximum Rating: ±100 mA per JEDEC standard: JESD78 class II.
4. Moisture Sensitivity Level (MSL): 1 per IPC/JEDEC standard: J-STD-020.

OPERATING CONDITIONS

Symbol	Parameter	Conditions	Min	Typ	Max	Unit
V_{IN}	Operational Power Supply		0.75		5.5	V
V_{EN}	Enable Voltage		0		5.5	V
V_{BIAS}	Bias voltage ($V_{BIAS} \geq$ best of V_{IN}, V_{out})		1.2		5.5	V
T_A	Ambient Temperature Range		-40	25	+85	°C
C_{IN}	Decoupling input capacitor		100			nF
C_{OUT}	Decoupling output capacitor		100			nF
$R_{\theta JA}$	Thermal Resistance Junction to Air	CSP6 (Note 5)		100		°C/W
I_{OUT}	Maximum DC current				2	A
P_D	Power Dissipation Rating	(Note 6)		0.2		W

Functional operation above the stresses listed in the Recommended Operating Ranges is not implied. Extended exposure to stresses beyond the Recommended Operating Ranges limits may affect device reliability.

5. The $R_{\theta JA}$ is dependent of the PCB heat dissipation and thermal via.
6. The maximum power dissipation (P_D) is given by the following formula:

$$P_D = \frac{T_{JMAX} - T_A}{R_{\theta JA}}$$

NCP456R, NCP457

ELECTRICAL CHARACTERISTICS Min & Max Limits apply for T_A between -40°C to $+85^{\circ}\text{C}$ for V_{IN} and V_{BIAS} between 0.75 V to 5.5 V (Unless otherwise noted). Typical values are referenced to $T_A = +25^{\circ}\text{C}$, $V_{IN} = 3.3\text{ V}$ and $V_{BIAS} = 5\text{ V}$ (Unless otherwise noted).

Symbol	Parameter	Conditions	Min	Typ	Max	Unit	
POWER SWITCH							
$R_{DS(on)}$	Static drain-source on-state resistance for each rail	$V_{IN} = V_{BIAS} = 5.5\text{ V}$	$T_A = 25^{\circ}\text{C}$		24	33	$\text{m}\Omega$
			$T_J = 125^{\circ}\text{C}$			39	
		$V_{IN} = V_{BIAS} = 3.3\text{ V}$	$T_A = 25^{\circ}\text{C}$		24	33	
			$T_J = 125^{\circ}\text{C}$			39	
		$V_{IN} = V_{BIAS} = 1.8\text{ V}$	$T_A = 25^{\circ}\text{C}$		25	34	
			$T_J = 125^{\circ}\text{C}$			40	
		$V_{IN} = V_{BIAS} = 1.5\text{ V}$	$T_A = 25^{\circ}\text{C}$		26	35	
			$T_J = 125^{\circ}\text{C}$			41	
		$V_{IN} = V_{BIAS} = 1.2\text{ V}$	$T_A = 25^{\circ}\text{C}$		28	40	
			$T_J = 125^{\circ}\text{C}$			42	
$V_{IN} = 1.0\text{ V},$ $V_{BIAS} = 1.2\text{ V}$	$T_A = 25^{\circ}\text{C}$		30	40			
	$T_J = 125^{\circ}\text{C}$			42			
$V_{IN} = 0.8\text{ V},$ $V_{BIAS} = 1.2\text{ V}$	$T_A = 25^{\circ}\text{C}$		35	45			
	$T_J = 125^{\circ}\text{C}$			50			
R_{DIS}	Output discharge path		EN = low, NCP457		220	Ω	

TIMINGS

T_R	Output rise time	$V_{IN} = 5\text{ V}$	No cap on GATE pin		0.11		ms
			Gate capacitor = 1 nF		1.4		
			Gate capacitor = 10 nF		15.7		
T_F	Output fall time		$C_{LOAD} = 1\ \mu\text{F}, R_{LOAD} = 25\ \Omega$ (Note 8)		50		μs
T_{en}	Enable time		From EN low to high to $V_{out} = 10\%$ of fully on- NCP456R. 10 nF gate capacitor		3		ms
			From EN low to high to $V_{out} = 10\%$ of fully on- NCP456R. 1 nF gate capacitor		300		μs
			From EN low to high to $V_{out} = 10\%$ of fully on- NCP456R. Without gate capacitor		51		μs

Product parametric performance is indicated in the Electrical Characteristics for the listed test conditions, unless otherwise noted. Product performance may not be indicated by the Electrical Characteristics if operated under different conditions.

7. Parameters are guaranteed for C_{LOAD} and R_{LOAD} connected to the OUT pin with respect to the ground

8. Guaranteed by design and characterization, not production tested.

NCP456R, NCP457

ELECTRICAL CHARACTERISTICS Min & Max Limits apply for T_A between -40°C to $+85^{\circ}\text{C}$ for V_{IN} and V_{BIAS} between 0.75 V to 5.5 V (Unless otherwise noted). Typical values are referenced to $T_A = +25^{\circ}\text{C}$, $V_{IN} = 3.3\text{ V}$ and $V_{BIAS} = 5\text{ V}$ (Unless otherwise noted).

Symbol	Parameter	Conditions	Min	Typ	Max	Unit
--------	-----------	------------	-----	-----	-----	------

TIMINGS

T_R	Output rise time	$V_{IN} = 3.3\text{ V}$	No cap on GATE pin	0.1	0.3	ms	
			Gate capacitor = 1 nF	1			
			Gate capacitor = 10 nF	11			
T_F	Output fall time		$C_{LOAD} = 1\ \mu\text{F}$, $R_{LOAD} = 25\ \Omega$ (Note 8)	60	120	μs	
T_{en}	Enable time		From EN low to high to $V_{out} = 10\%$ of fully on– NCP456R. 10 nF Gate capacitor.	2.4		ms	
			From EN low to high to $V_{out} = 10\%$ of fully on– NCP456R. 1 nF Gate capacitor.	230		μs	
			From EN low to high to $V_{out} = 10\%$ of fully on– NCP456R. Without gate capacitor	50	120	μs	
T_R	Output rise time		$V_{IN} = 1.8\text{ V}$	No cap on GATE pin	0.06		ms
				Gate capacitor = 1 nF	0.6		
		Gate capacitor = 10 nF		6			
T_F	Output fall time	$C_{LOAD} = 1\ \mu\text{F}$, $R_{LOAD} = 25\ \Omega$ (Note 8)		35		μs	
T_{en}	Enable time	From EN low to high to $V_{out} = 10\%$ of fully on– 10 nF Gate capacitor		1.8		ms	
		From EN low to high to $V_{out} = 10\%$ of fully on– 1 nF Gate capacitor		180		μs	
		From EN low to high to $V_{out} = 10\%$ of fully on– NCP456R. Without gate capacitor		42		μs	
T_R	Output rise time	$V_{IN} = 1\text{ V}$		No cap on GATE pin	0.04		ms
				Gate capacitor = 1 nF	0.35		
			Gate capacitor = 10 nF	3.5			
T_F	Output fall time		$C_{LOAD} = 1\ \mu\text{F}$, $R_{LOAD} = 25\ \Omega$ (Note 8)	20		μs	
T_{en}	Enable time		From EN low to high to $V_{out} = 10\%$ of fully on– NCP456R. 1 nF gate capacitor	140		μs	
			From EN low to high to $V_{out} = 10\%$ of fully on– NCP456R. Without gate capacitor	40		μs	

LOGIC

V_{IH}	High-level input voltage	0.9			V
V_{IL}	Low-level input voltage			0.4	V
R_{EN}	Pull down resistor	3		7	$\text{M}\Omega$

Product parametric performance is indicated in the Electrical Characteristics for the listed test conditions, unless otherwise noted. Product performance may not be indicated by the Electrical Characteristics if operated under different conditions.

7. Parameters are guaranteed for C_{LOAD} and R_{LOAD} connected to the OUT pin with respect to the ground

8. Guaranteed by design and characterization, not production tested.

NCP456R, NCP457

ELECTRICAL CHARACTERISTICS Min & Max Limits apply for T_A between -40°C to $+85^{\circ}\text{C}$ for V_{IN} and V_{BIAS} between 0.75 V to 5.5 V (Unless otherwise noted). Typical values are referenced to $T_A = +25^{\circ}\text{C}$, $V_{IN} = 3.3\text{ V}$ and $V_{BIAS} = 5\text{ V}$ (Unless otherwise noted).

Symbol	Parameter	Conditions	Min	Typ	Max	Unit
--------	-----------	------------	-----	-----	-----	------

REVERSE CURRENT BLOCKING

V_{rev_thr}	Reverse threshold	$V_{out}-V_{in}$		32		mV
V_{rev_hyst}	Reverse threshold hysteresis			50		mV
T_{rev}	Reverse comparator response time	$V_{out}-V_{in} > V_{rev_thr}$		2.5		μs

QUIESCENT CURRENT- NCP456R

I_{VBIAS}	Bias current for charge pump	$V_{BIAS} = 3.3\text{ V}$, EN = high		1.5	6	μA
I_{IN}	IN Current consumption	EN = high		0.01	0.3	μA
I_{STB}	Standby current IN	EN = low, IN standby current, $V_{IN} = 3.3\text{ V}$		0.01	0.3	μA
$I_{STDVbias}$	Standby current V_{BIAS}	$V_{BIAS} = 3.3\text{ V}$ EN = low		0.4	2	μA
I_{out_leak}	Output leakage current	IN connected to GND, $V_{OUT} = 5\text{ V}$		0.01	0.5	μA

QUIESCENT CURRENT- NCP457

I_{VBIAS}	Bias current for charge pump	$V_{BIAS} = 3.3\text{ V}$, EN = high		1.3	5	μA
I_Q	IN Current consumption	EN = high		0.01	0.3	μA
I_{STB}	Standby current IN	EN = low, IN standby current, $V_{IN} = 3.3\text{ V}$		0.01	1.6	μA
$I_{STDVbias}$	Standby current V_{BIAS}	$V_{BIAS} = 3.3\text{ V}$ EN = low		0.4	2	μA

Product parametric performance is indicated in the Electrical Characteristics for the listed test conditions, unless otherwise noted. Product performance may not be indicated by the Electrical Characteristics if operated under different conditions.

7. Parameters are guaranteed for C_{LOAD} and R_{LOAD} connected to the OUT pin with respect to the ground
8. Guaranteed by design and characterization, not production tested.

NCP456R, NCP457

TIMINGS

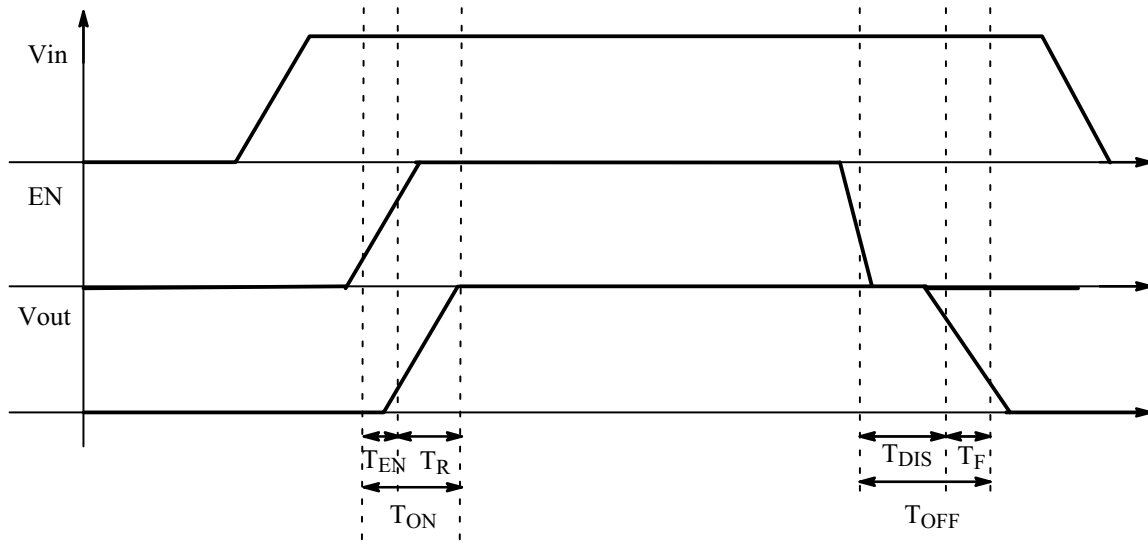

Figure 5. Enable, Rise and Fall Time

NCP456R, NCP457

TYPICAL CHARACTERISTICS

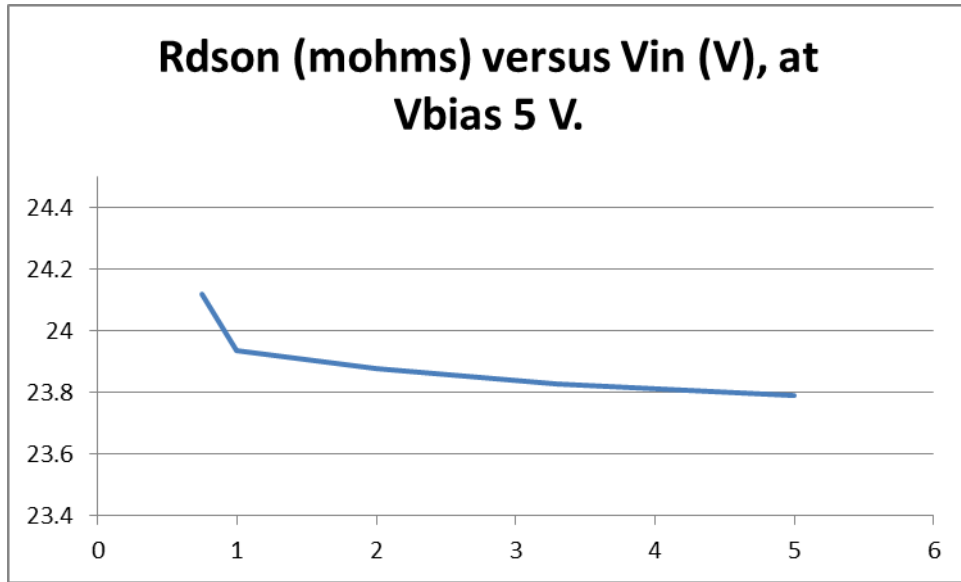

Figure 6. $R_{DS(on)}$ versus V_{in} , Room Temperature, Vbias 5 V

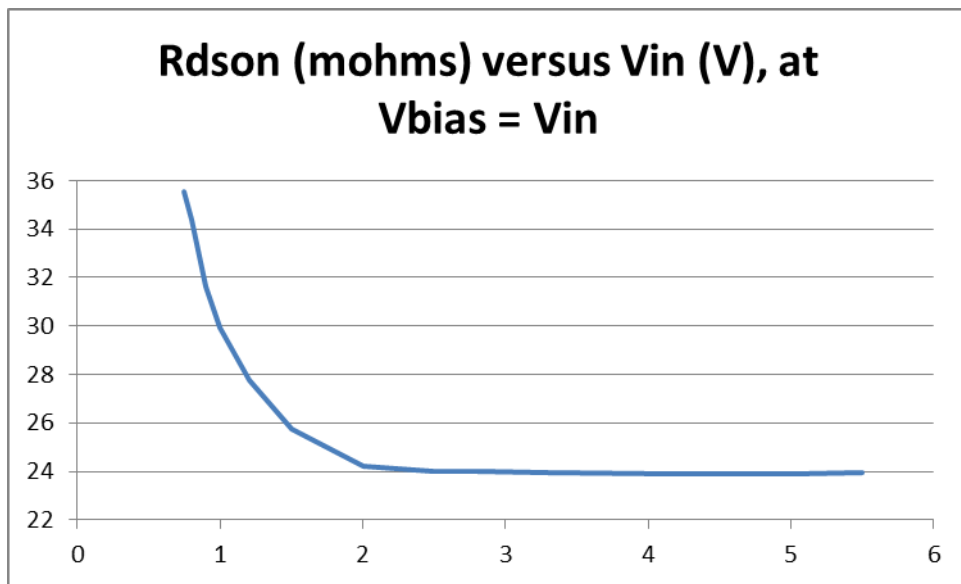

Figure 7. $R_{DS(on)}$ versus V_{in} , Room Temperature, Vbias Connected to V_{in}

NCP456R, NCP457

FUNCTIONAL DESCRIPTION

Overview

The NCP456R and NCP457 are high side N Channel MOSFET power distribution switch designed to isolate ICs connected on the battery or DCDC supplies in order to save energy. The part can be used with a wide range of supply from 0.75 V to 5.5 V.

Enable input

Enable pin is an active high. The path is opened when EN pin is tied low (disable), forcing NMOS switch off.

The IN/OUT path is activated with a minimum of $V_{BIAS} \geq \text{best of } V_{IN}, V_{OUT} = 0.75 \text{ V}$ and EN forced to high level.

Auto Discharge (Optional – NCP457)

NMOS FET is placed between the output pin and GND, in order to discharge the application capacitor connected on OUT pin.

The auto-discharge is activated when EN pin is set to low level (disable state).

The discharge path (Pull down NMOS) stays activated as long as EN pin is set at low level and $V_{BIAS} > 0.75 \text{ V}$.

In order to limit the current across the internal discharge N-MOSFET, the typical value is set at 220 Ω .

V_{BIAS} Rail

The core of the IC is supplied due to V_{BIAS} supply rail (common +5 V, 3.3 V, 1.8 V, 1.2 V ...etc). Indeed, no current consumption is used on IN pin, allowing to improve power saving of the rail that must be isolated by the power switch.

If V_{bias} rail is not available or used, V_{bias} pin and V_{in} pin can be connected together as close as possible the DUT.

Output Rise Time – Gate Control

The NMOS is control with internal charge pump and driver. A minimum gate slew rate is internally set to avoid huge inrush current when EN is set from low to high. The default gate slew rate depends on V_{in} level. The higher V_{in} level, the longer rise time.

In addition, an external capacitor can be connected between Gate pin and GND in order to slow down the gate rising. See electrical table for more details.

C_{in} and C_{out} Capacitors

100 nF external capacitors must be connected as close as possible the DUT for noise immunity and better stability. In case of input hot plug (input voltage connected with fast slew rate – few μs – it's strongly recommended to avoid big capacitor connected on the input. That allows to avoid input over voltage transients.

Reverse Blocking Control (Optional NCP456R)

A reverse blocking control circuitry is embedded to eliminate leakages from OUT to IN in case of $V_{out} > V_{in}$.

A comparator measures the dropout voltage on the switch between OUT and IN and turn off the NMOS if this voltage exceeds specified reverse voltage. This comparator is available whatever the EN pin level.

APPLICATION INFORMATION

Power Dissipation

Main contributor in term of junction temperature is the power dissipation of the power MOSFET. Assuming this, the power dissipation and the junction temperature in normal mode can be calculated with the following equations:

$$P_D = R_{DS(on)} \times (I_{out})^2 \quad (\text{eq. 1})$$

P_D = Power dissipation (W)
 $R_{DS(on)}$ = Power MOSFET on resistance (Ω)
 I_{out} = Output current (A)

$$T_J = R_D \times R_{\theta JA} + T_A \quad (\text{eq. 2})$$

T_J = Junction temperature ($^{\circ}\text{C}$)
 $R_{\theta JA}$ = Package thermal resistance ($^{\circ}\text{C}/\text{W}$)
 T_A = Ambient temperature ($^{\circ}\text{C}$)

Demoboard

The NCP456R and NCP457 integrate a 2 A rated NMOS FET, and the PCB rules must be respected to properly evacuate the heat out of the silicon.

The package is a CSP and due to the low thermal resistance of the silicon, all the balls can be used to improved power dissipation. Indeed, even if the power crosses the IN / OUT pins only, all the balls around this power area should be connected to the larger PCB area.

In the below PCB example (application demonstration board), all the PCB areas connected to 6 balls are enlarged. In addition vias are connected to bottom side with exactly same form factor of the other PCB side.

Additional improvements can be done also by using more copper thickness and the thinner epoxy as possible.

NCP456R, NCP457

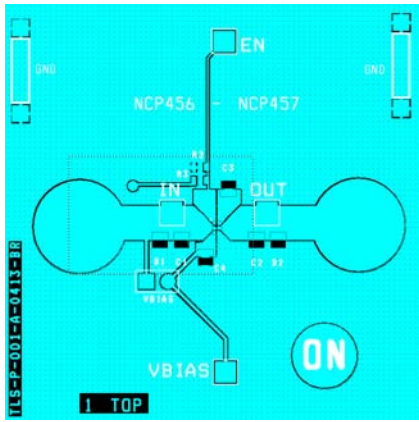

Figure 8. PCB Top View

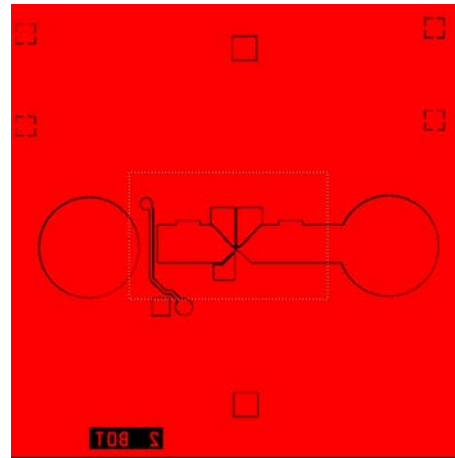

Figure 9. PCB Bottom View

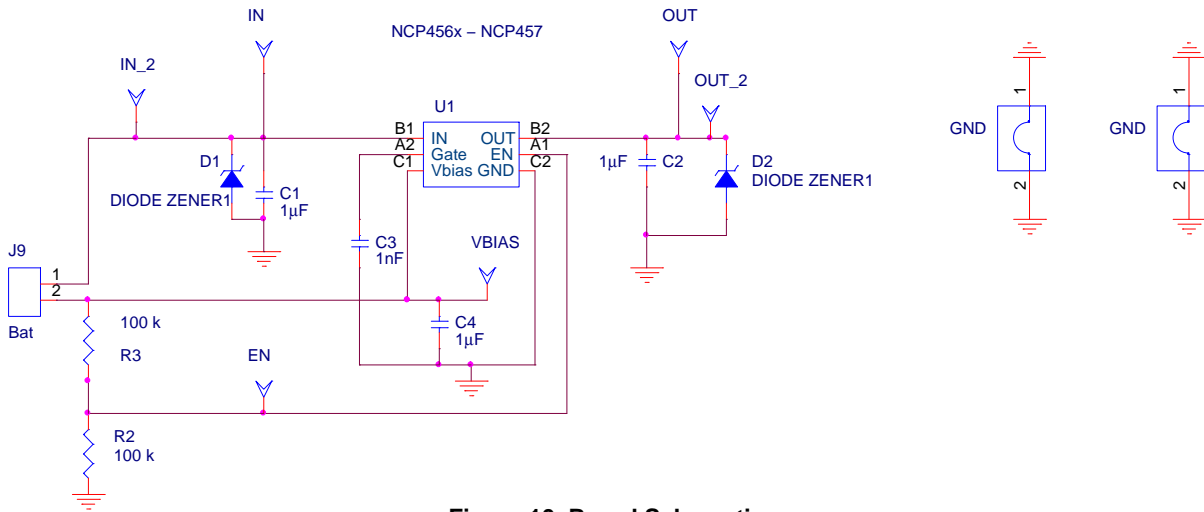

Figure 10. Board Schematic

NCP456R, NCP457

BILL OF MATERIAL

Quantity	Reference schem	Part description	Part number	Manufacturer
2	IN, OUT	Socket, 4mm, metal, PK5	B010	HIRSCHMANN
4	IN_2, OUT_2, VBIAS, EN	HEADER200	2.54 mm, 77313-101-06LF	FC
1	J9 (Bat)	HEADER200-2	2.54 mm, 77313-101-06LF	FC
3	C1, C2, C4	1uF	GRM155R70J105KA12#	Murata
1	C3	1nF, Not mounted	GRM188R60J102ME47#	Murata
1	D1, D2	TVS	ESD9x	ON semiconductor
2	GND2,GND	GND JUMPER	D3082F05	Harvin
2	R2, R3	Resistor 100k 0603	MC 0.063 0603 1% 100K	MULTICOMP
1	U1	Load switch	NCP456 - 457	ON semiconductor

ORDERING INFORMATION

Device	Options	Marking	Package	Shipping
NCP456RFCCT2G	Reverse Voltage Protection	56dYW	WLCSP 1.25 x 0.85 mm (Pb-Free)	3000 Tape / Reel
NCP457FCT2G	Discharge Path	57dYW	WLCSP 1.25 x 0.85 mm (Pb-Free)	3000 Tape / Reel

†For information on tape and reel specifications, including part orientation and tape sizes, please refer to our Tape and Reel Packaging Specifications Brochure, BRD8011/D.

NCP456R, NCP457

PACKAGE DIMENSIONS

WLCSP6, 1.25x0.85
CASE 567GZ
ISSUE B

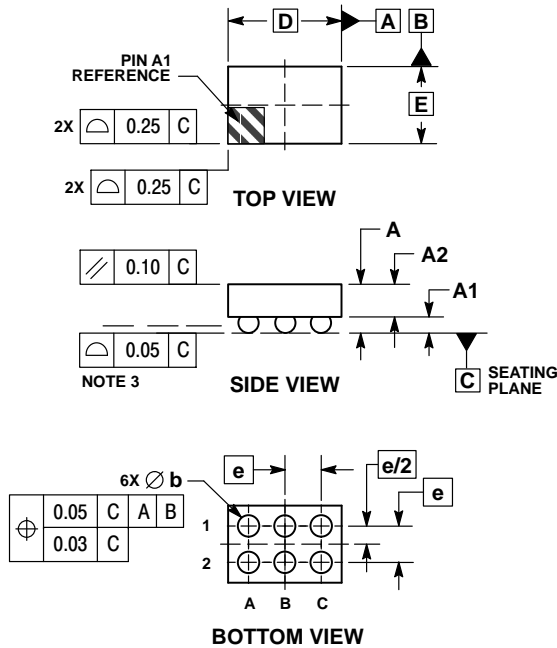

NOTES:

1. DIMENSIONING AND TOLERANCING PER ASME Y14.5M, 1994.
2. CONTROLLING DIMENSION: MILLIMETERS.
3. COPLANARITY APPLIES TO THE SPHERICAL CROWNS OF THE SOLDER BALLS.

DIM	MILLIMETERS	
	MIN	MAX
A	---	0.62
A1	0.17	0.23
A2	0.36	REF
b	0.24	0.29
D	1.25	BSC
E	0.85	BSC
e	0.40	BSC

RECOMMENDED SOLDERING FOOTPRINT*

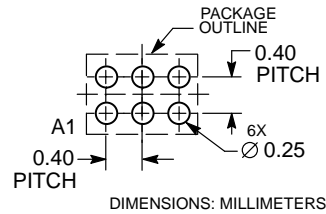

*For additional information on our Pb-Free strategy and soldering details, please download the ON Semiconductor Soldering and Mounting Techniques Reference Manual, SOLDERRM/D.

ON Semiconductor and are registered trademarks of Semiconductor Components Industries, LLC (SCILLC). SCILLC owns the rights to a number of patents, trademarks, copyrights, trade secrets, and other intellectual property. A listing of SCILLC's product/patent coverage may be accessed at www.onsemi.com/site/pdf/Patent-Marking.pdf. SCILLC reserves the right to make changes without further notice to any products herein. SCILLC makes no warranty, representation or guarantee regarding the suitability of its products for any particular purpose, nor does SCILLC assume any liability arising out of the application or use of any product or circuit, and specifically disclaims any and all liability, including without limitation special, consequential or incidental damages. "Typical" parameters which may be provided in SCILLC data sheets and/or specifications can and do vary in different applications and actual performance may vary over time. All operating parameters, including "Typicals" must be validated for each customer application by customer's technical experts. SCILLC does not convey any license under its patent rights nor the rights of others. SCILLC products are not designed, intended, or authorized for use as components in systems intended for surgical implant into the body, or other applications intended to support or sustain life, or for any other application in which the failure of the SCILLC product could create a situation where personal injury or death may occur. Should Buyer purchase or use SCILLC products for any such unintended or unauthorized application, Buyer shall indemnify and hold SCILLC and its officers, employees, subsidiaries, affiliates, and distributors harmless against all claims, costs, damages, and expenses, and reasonable attorney fees arising out of, directly or indirectly, any claim of personal injury or death associated with such unintended or unauthorized use, even if such claim alleges that SCILLC was negligent regarding the design or manufacture of the part. SCILLC is an Equal Opportunity/Affirmative Action Employer. This literature is subject to all applicable copyright laws and is not for resale in any manner.

PUBLICATION ORDERING INFORMATION

LITERATURE FULFILLMENT:
Literature Distribution Center for ON Semiconductor
P.O. Box 5163, Denver, Colorado 80217 USA
Phone: 303-675-2175 or 800-344-3860 Toll Free USA/Canada
Fax: 303-675-2176 or 800-344-3867 Toll Free USA/Canada
Email: orderlit@onsemi.com

N. American Technical Support: 800-282-9855 Toll Free
USA/Canada
Europe, Middle East and Africa Technical Support:
Phone: 421 33 790 2910
Japan Customer Focus Center
Phone: 81-3-5817-1050

ON Semiconductor Website: www.onsemi.com
Order Literature: <http://www.onsemi.com/orderlit>
For additional information, please contact your local Sales Representative

Looking for pricing, stock, or lifecycle information?

Click below to explore more details on WIN SOURCE:

 [View NCP456RFCCT2G on WIN SOURCE](#)

 [ON Semiconductor](#) Information

Optimize Your Supply Chain with WIN SOURCE Solutions

-  Global Sourcing Solution
-  Obsolete Management
-  Cost Control Management
-  Shortage Management
-  Alternative Solution
-  Excess Inventory Management